

READ AND
SAVE THESE
INSTRUCTIONS

SEARS

owner's
manual

Stock No.
42-14411

Model No.
758.144115

**FOR YOUR
SAFETY:**

READ
ALL INSTRUCTIONS
CAREFULLY

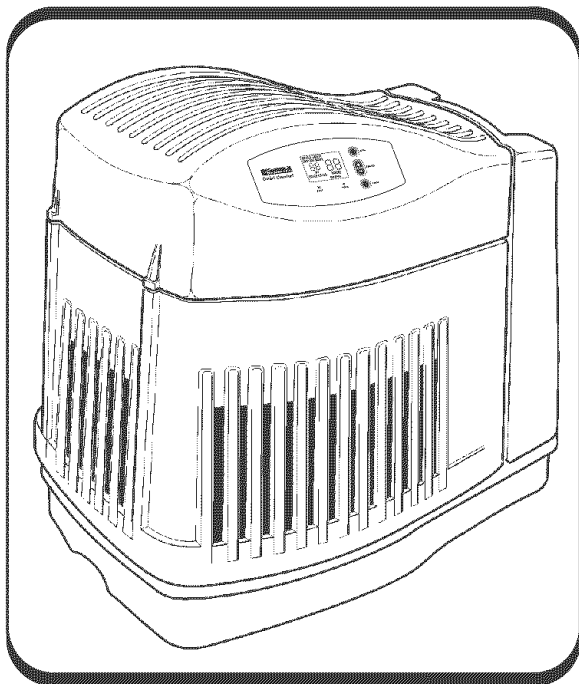

Kenmore[®]

QUIET COMFORT

**CONTEMPORARY
WHOLE HOUSE
HUMIDIFIER**

**11 Gallon Output with
Digital Readout**

- Operating Instructions
- Parts List

Sears, Roebuck and Co., Hoffman Estates, IL 60179 U.S.A.

FULL ONE YEAR WARRANTY ON HUMIDIFIER

If within one (1) year from the date of purchase, this humidifier fails due to a defect in material or workmanship, Sears will repair it, free of charge. If within two (2) years from the date of purchase, the motor fails due to defect in material or workmanship, Sears will repair it free of charge.

This warranty service is available by simply returning the humidifier to the nearest Sears Service Center/Department throughout the United States.

This warranty applies only while this product is used in the United States.

This warranty gives you specific legal rights, and you may also have other rights which vary from state to state.

Sears, Roebuck and Co., D/817 WA, Hoffman Estates, IL 60179

GENERAL SAFETY INSTRUCTIONS

Safety Signal Words

DANGER: means if the safety information is not followed, someone will be seriously injured or killed.

WARNING: means if the safety information is not followed, someone could be seriously injured or killed.

CAUTION: means if the safety information is not followed, someone may be seriously injured or killed.

1. To reduce the risk of fire or shock hazard, plug humidifier directly into a 120V, A.C. electrical outlet. Do not use extension cords.
2. Keep the electric cord out of traffic areas. To reduce the risk of fire hazard, never put the electric cord under rugs, near heat registers, radiators, stoves or heaters.
3. Always unplug the humidifier before moving it, before cleaning, or whenever the humidifier is not in service.
4. Keep the humidifier clean.

5. Do not put foreign objects inside the humidifier.
6. Do not allow to be used as a toy. Close attention is necessary when used by or near children.
7. Never use your humidifier while any part is missing or damaged in any manner.
8. To reduce the risk of electrical hazard or damage to humidifier, do not tilt, jolt or tip humidifier while unit is running.
9. To reduce the risk of damage to humidifier, unplug humidifier, when the base is empty or when the humidifier is not in use.
10. To reduce the risk of accidental electrical shock, do not touch the cord or controls with wet hands.
11. Note the warning label shown below.

WARNING: To reduce risk of fire, electric shock, or injury always unplug before filling, servicing or cleaning.

Table of Contents

Warranty Information	2
General Safety Instructions	2
To Save A Service Call	2
Know Your Humidifier	3
Humidifier Operation	4
Unpacking and Assembly	4
Location Instructions	5
Electrical Hook-Up	5

Water Fill	6-7
Operating Humidifier Controls	7
Using Your Humidifier	11
Operating Tips for Best Performance	11
Replacement and Care of Filters	12-13
Cleaning Your Humidifier	14-15
Troubleshooting	16-17
Repair Parts	18-19

To Save a Service Call

Check the following if your humidifier is not operating.

1. Is power cord attached to outlet?
2. Is there electrical power to outlet?

3. Is airflow control in operating position?
4. Is humidity control set high enough?
5. Is the cabinet sitting on a level surface?

Know Your Humidifier

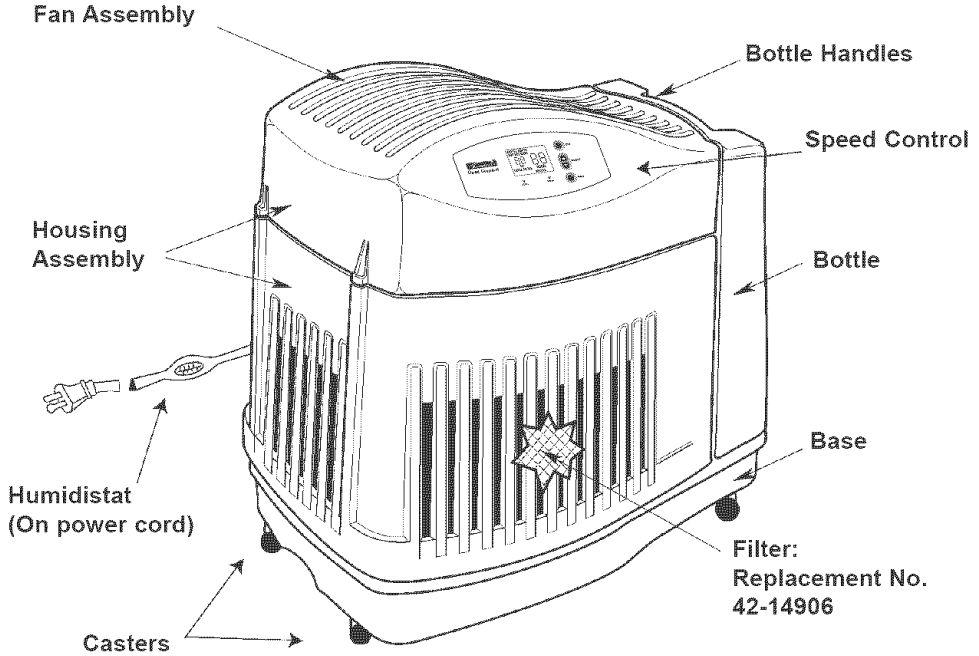

Description	42-14411
Gallon Output/24 hrs	11
Capacity of Bottle	1.9 Gallons
Capacity of Base	2.0 Gallons
* Sq. Ft. Coverage	2300
Fan Speeds	4
Replacement Filter	42-14906
Power Light	Yes
Fill Light	Yes
Auto Humidistat	Yes
Auto Shut Off	Yes
Controls	Electronic (Push Button)
Casters	Yes (4)
CUL Listed	Yes
Volts	120 A.C.
Hertz	60
Amps	0.80
Watts	80

* Based on an area with average insulation and an 8 foot ceiling height.

Humidifier Operation

Your new Sears humidifier is designed to satisfy home humidity requirements through the principle of evaporation of water in the air.

After water is added to the humidifier, the filter begins to soak up the water and will become saturated in approximately 30 minutes. Air drawn in through the openings in the lower housing passes through the filter by means of a circulation fan. As air passes through the filter, moisture is absorbed into the air and then released in the form of vapor. No water droplets will enter the home. All evaporation into the air takes place in the humidifier, which means that the residue left by evaporating water is not passed into the home, but remains in the filter.

This natural process of evaporation helps eliminate the chance of white dust in the humidified output air.

CAUTION: Use only 42-14900 EPA Registered Bacteriostat available from SEARS Retail store. Under no circumstances should you use water treatment products designed for Roto belt or Ultrasonic humidifiers.

Humidified air is then released through the top

Dry air enters through the louvers in the housing

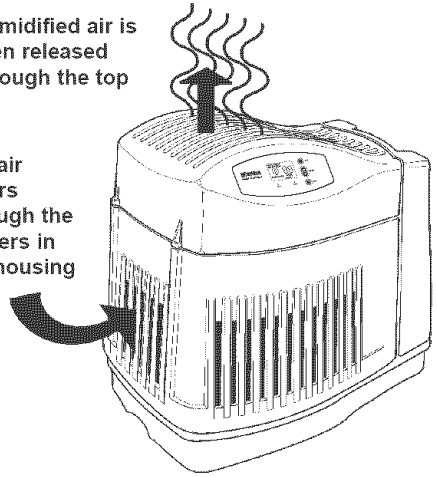

CAUTION: To reduce the risk of injury, fire or damage to humidifier, use only cleaners specifically recommended for humidifiers. Never use flammable, combustible or poisonous materials to clean your humidifier. To reduce the risk of scalds and damage to humidifier, never put hot water in humidifier.

Unpacking and Assembly

Your new Sears Kenmore humidifier is supplied with four swivel casters for ease of maneuverability. Remove the casters from the top of the packing material inside the carton. The casters press into the bottom of the base at the locations shown. To make assembly easier remove the water bottle, housing assembly and filter and flip the base upside to install. See steps 2-4 of "Replacement and Care of Filters" section on page 12 for procedure. Take care not to damage the floats or base assembly if choosing this method of assembly. Press casters into location beside X.

Note: Casters should be installed manually. Do not use any tools to install them. Once installed return the unit to its original state and proceed to "Location Instructions."

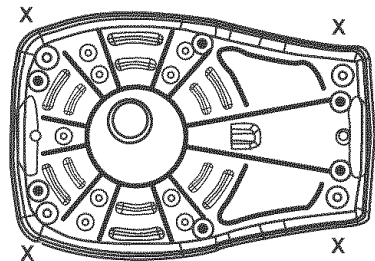

Location Instructions

WARNING: For your own safety, do not use humidifier if any parts are damaged or missing.

Step 1

Place humidifier on a flat level surface in an area of house where most humidity is needed, or one which would likely result in moist air being circulated throughout the house such as near a cold air return. Placing the unit level is very important. Special attention should be given to unit's level if the humidifier is located on carpeting. Moist air (humidity) produced will disperse into the whole house, but the area closest to the unit will have the highest humidity. If the unit is positioned close to a window, condensation may form on the window pane. If this is not appropriate the unit should be repositioned in another location.

NOTE: Due to release of cool, moist air from humidifier, it is best to direct air away from home thermostat and hot air registers. It is best to position humidifier next to an inside wall. Hot air registers and cold air from outside walls can affect the efficiencies of the controls. Unit should not be placed where warm air from a hot air register blows directly on unit.

Electrical Hook-Up

Locate nearest 120V A.C. wall socket in the location desired, preferably on inside wall. With the humidifier in the desired location, route the electrical cord safely so no one will trip or upset the humidifier. Plug in the electrical cord.

WARNING: To reduce the risk of fire or shock hazard, humidifier should be plugged into a 120V A.C. outlet. Do not use extension cords.

To reduce the risk of electrical shock, this humidifier has a polarized plug (one blade is wider than the other). This plug will fit in a polarized outlet only one way.

Step 2

The humidifier should be positioned with the back (cord exit side) and left side, at least 2 inches away from the wall. Air needs to enter through all of the louvers in the housing assembly in order for the humidifier to operate at peak efficiency.

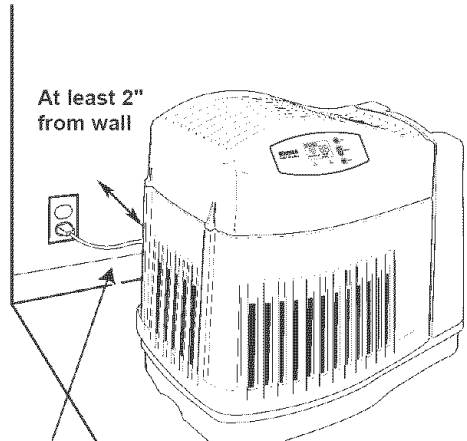

Note: Be sure humidistat located approximately 4 inches outside humidifier body on power cord is free from obstruction and away from any hot air register.

If the plug does not fit fully in the outlet, reverse plug. If it still does not fit, contact a qualified electrician to install the proper outlet. Do not change the plug in any way.

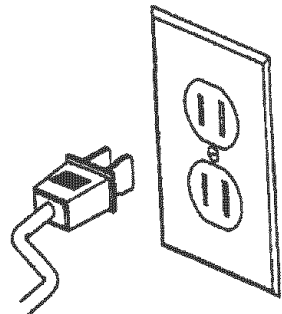

Water Fill

WARNING: To reduce the risk of shock, always unplug humidifier before cleaning or servicing.

WARNING: To reduce the risk of fire or shock hazard, do not pour or spill water into control or motor area. If controls get wet, let them dry completely and have unit checked by authorized service personnel before plugging in.

This humidifier is designed for use with the water bottle located to the right of the upper grill. The water bottle holds 1.9 gallons of water. The humidifier should be positioned where it will be operating.

To fill the whole house humidifier, grasp the bottle handle at the top of the bottle and lift it straight up and away from humidifier base. Take care not to bump or damage spring valve assembly on bottom of bottle.

NOTE: If it is desired to use approved bacteriostat, follow directions correctly.

The bottle of the whole house humidifier will hold 1.9 gallons of water.

The water bottle is designed with an "E-Z-Fill Side-Cap". Remove the "E-Z-Fill Side-Cap" on the side of the water bottle by twisting counterclockwise.

Place the opening of the water bottle under a water faucet and fill. If desired, add Sears liquid bacteriostat (stock number 42-14900) to help control the build up of bacteria and algae. Do not use solid water treatments. Solid debris could make the lower valve leak.

Install the "E-Z-Fill Side-Cap" by twisting clockwise. Hand tighten only.

Check for possible leaks by performing the following:

1. Grasp bottle handle and hold the bottle upright over a sink.
2. Press up on valve plunger for about one second to let out a little water.
3. Release the plunger.

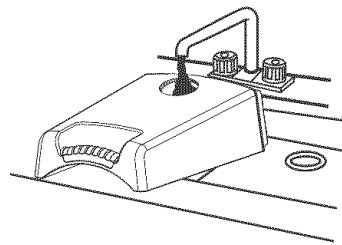
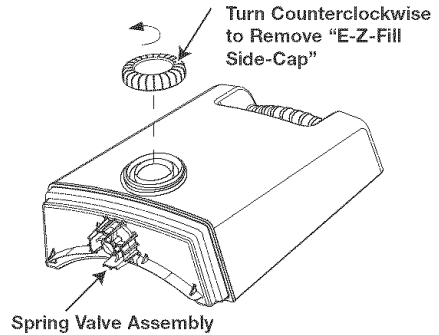
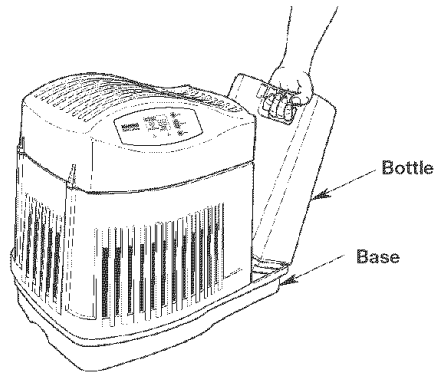

4. Listen for air bubbles. Look for leaks around the "E-Z-Fill Side-Cap" and valve plunger.
5. If you hear air bubbles or see leaks, retighten the "E-Z-Fill Side-Cap" and repeat steps 1-4.

Wipe off excess water from the bottle. Position the water bottle back into the humidifier base to the right of the grille. The "E-Z-Fill Side-Cap" must be facing outward. When positioned properly, the plunger will open and water will flow into the base. The base will hold the entire contents of the water bottle. Allow up to one minute for the water to flow into the base. Once the bottle is empty, remove it and refill it as mentioned earlier. Return it to the right side of the grille. The humidifier is now filled to capacity.

The water bottle may be filled at anytime as necessary during operation. To benefit from less frequent filling let the humidifier exhaust both the water from the bottle and base before filling. The unit is now ready for operation.

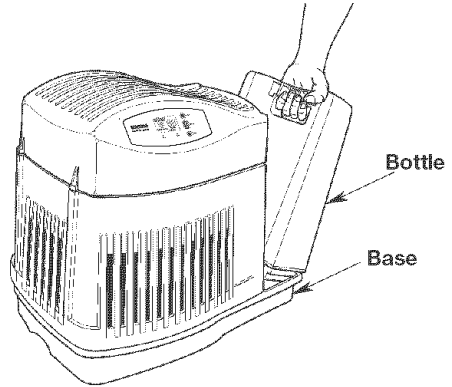

Operating Humidifier Controls

The operating controls of your Kenmore Quiet Comfort whole house humidifier are located towards the front of the humidifier.

Familiarize yourself with the controls. Reference the diagram of the control area for the correct nomenclature used in this manual.

To Operate the Controls

Power Button / Light

When the unit is plugged in and the power button is pressed once the red power light will come on. The power light will stay on until the power button is pressed again turning the unit off or until the unit is unplugged.

Digital Display

The digital display will also show readouts when the unit is turned on. Initially there is a slight delay while the electronics calibrate. Two bars (- -) flash during this time. Once calibration is complete a

ROOM humidity reading between 25% - 95% will be displayed. A flashing 25 display indicates that the room humidity is less than 25%.

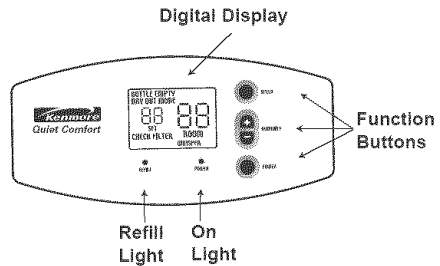

Note: The default settings at initial start-up are **WHISPER** fan speed and **65%** SET humidity. After desired settings are selected by the user, they remain as defaults as long as the unit remains plugged in and there is no power interruption. If the unit is unplugged the **original** default settings are employed.

Operating Humidifier Controls (cont'd)

Speed Button

This humidifier is equipped with a 4-speed fan control. Each push of the speed button advances the mode through the settings of **WHISPER**, **HIGH**, **MEDIUM** and **LOW**. The selected setting is displayed on the digital readout. The higher the setting, the faster water is evaporated and released into the air.

WHISPER is the quietest setting and is provided for conditions that do not require a rapid evaporation rate.

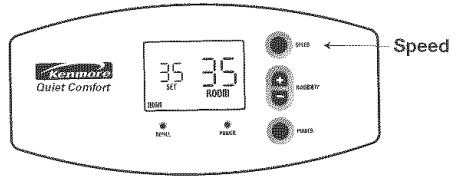

Humidity Control

The +/- buttons allow you to adjust the humidity to suit your needs. This humidifier will automatically cycle on and off as required to maintain the selected setting. The readout displays both actual (**ROOM**) and desired (**SET**) humidity percentage (%) settings. The **ROOM** reading is the larger display of the two. The **ROOM** readout is displayed in 1% increments and has a range of 25% to 95%. If the room humidity level is equal to or less than 25% the display will show a flashing 25.

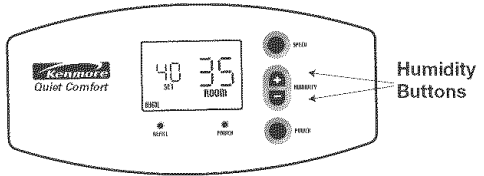

The **SET** readout has a range of 30% to 65% and is adjusted in increments of 5%. Each press of the

(+) button increases the setting by 5% and conversely each press of the (-) button decreases the setting by 5%. A **SET** point of 65% operates the humidifier continuously regardless of the **ROOM** reading.

The humidistat that senses the readings is located on the power cord. Insure that it is free from obstruction.

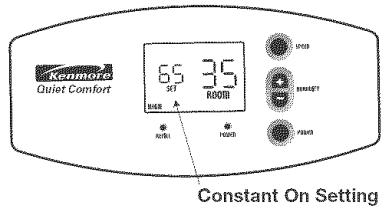

Operating Humidifier Controls (cont'd)

Refill Light

The humidifier base and bottle hold approximately 2 gallons of water each. The bottle empties into the base during operation. When the base empties the amber **REFILL** light will illuminate informing additional water is required. Also at this time the unit will automatically switch into "**DRY OUT MODE**" and continue to run on **WHISPER** speed until the filter is dry. The message "**DRY OUT MODE**" will appear on the digital display and the fan speed will switch to **WHISPER** speed. **Note:** The digital display will still show the speed the humidifier was operating in before the **REFILL** light turned on even though the fan is operating at **WHISPER** speed. During this time the room humidity level will continue to be monitored and the humidifier will cycle the fan on and off as required. If **DRY OUT MODE** is not desired, refill the humidifier with water. **Note:** Once the dry out cycle is complete the fan will shut off and the **REFILL** light will stay illuminated. The humidifier will automatically start again when it is refilled.

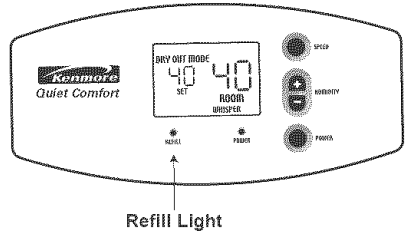

Bottle Empty Indicator

This humidifier employs a "double fill" bottle system. If the base is empty the contents of the bottle will completely empty into it. The bottle can be refilled and returned to the unit. The humidifier is now capable of providing its maximum run time between fills. Once the bottle empties a flashing "**BOTTLE EMPTY**" message will appear on the display panel. The unit will continue to run as programmed but the option of refilling the bottle is presented. Once filled the flashing message will turn off.

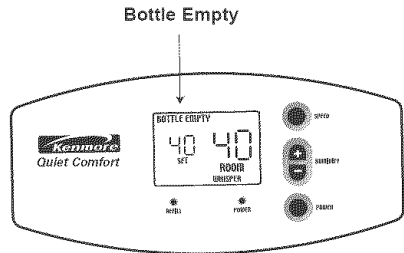

Humidifier Operations

Check Filter Indicator

The ability of any humidifier to efficiently supply humidity output relies heavily on the condition of the filter. As the filter loads with trapped impurities found in water it gradually loses its wicking capability. When this happens moisture output is reduced and the humidifier has to work longer to satisfy the selected setting. When such a condition occurs, a flashing "CHECK FILTER" message will be displayed. If the condition persists for more than 24 hours shut off the humidifier, disconnect the power and check the condition of the filter. If a buildup of deposits and severe discoloration is evident replace the filter to restore maximum efficiency.

Humidistat

The humidistat located on the power cord senses the percentage of humidity in the air. It causes the humidifier to cycle on and off to maintain the selected humidity SET point. The fan will turn on if the "ROOM" reading falls 3% below the SET point and will continue to run the humidifier until a reading of 1% above the SET point is achieved. At this point the fan will stop. The fan will remain off until the ROOM reading falls 3% below the SET point again.

Dry Out Mode

When both the water bottle and the base are empty the amber REFILL light will illuminate and the humidifier will automatically switch into DRY OUT MODE. The message DRY OUT MODE will appear on the digital display and the fan speed will automatically switch to WHISPER speed.

Note: The digital display will show the speed the humidifier was operating in before the REFILL light turned on even though the fan is operating on WHISPER speed. During this time the humidifier will continue to cycle the fan on and off as required until the filter is completely dry thus producing no moisture output. Once dry, the fan will shut off leaving you with a

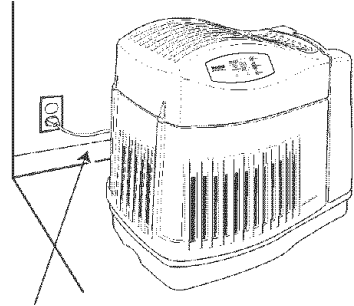
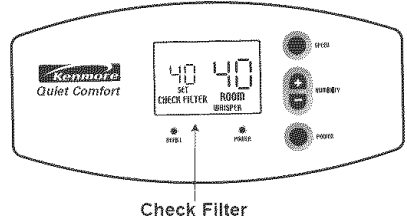

Note: Be sure humidistat located approximately 4 inches outside humidifier body on power cord is free from obstruction and away from any hot air register.

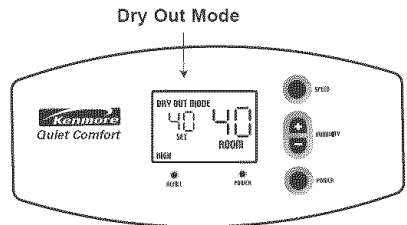

Note: Fan automatically switches to "WHISPER" speed during "DRY OUT MODE". Display will still show programmed speed. i.e: HIGH

dry humidifier that is less prone to mold and mildew growth. The amber Refill light will be illuminated and the humidifier is ready for cleaning or refilling as desired.

Using Your Humidifier

1. Place the humidifier where you intend to run it and be sure it is plugged in and full of water.
2. Press the **POWER** button once to turn the humidifier on. The red power light will illuminate.

The fan will immediately operate on **WHISPER** speed and the **SET** humidity percentage will read 65 on the digital display.

NOTE: Humidifier fan should operate at initial start up. If it does not, refer to the "Trouble Shooting" section on page 16 of this manual.

3. Wait a few seconds while the humidifier takes a **ROOM** humidity reading. During this time two bars (- -) will flash on the display.
4. Once a **ROOM** reading has registered proceed to adjust the desired humidity percentage by pressing the + or - button. It will change the desired **SET** humidity level in increments of 5%.

If the room reading is a flashing 25, the humidity level is low. A **SET** point of 30% - 40% is recommended but there may be conditions that require a different setting. Depending on your particular environment it could take 24 hours and in some cases longer for the humidifier to reach your

desired humidity. It may take several fillings to bring the **ROOM** humidity level up to the **SET** point. A faster fan speed will accomplish this quicker. Once established adjust the fan speed to suit your needs.

IMPORTANT: Water damage may result if condensation starts to form on windows or walls. Humidity **SET** point should be lowered until condensation no longer forms.

5. If the humidifier stops running and the amber Refill light is not illuminated, the humidity level is at the normal requirements for that **SET** point. The table below shows recommended indoor humidity levels as it relates to outdoor temperatures.

When Outdoor Temperature is:	Recommended Indoor Relative Humidity is:
-10°F	20%
0°F	25%
10°F	30%
20°F & above	35%

Operating Tips for Best Performance

1. Position the humidifier next to an inside wall at least 2 inches from the wall and away from any heat registers.
2. Do not restrict airflow from entering or exiting the humidifier.
3. Use 42-14900 EPA approved bacteriostat (available at your local Sears store) to retard bacteria growth that may cause odors and may be harmful to your health.
4. Regular cleaning as instructed in "Cleaning Your Humidifier" section of this manual is recommended.
5. Replace the evaporative wicking filter at least once per humidification season or more depending on water conditions in your area.
6. Ensure humidistat located on power cord is free from any obstruction and is away from heating vents or other sources of heat.

Replacement and Care of Filters

WARNING: To reduce the risk of shock or injury from moving parts, always unplug humidifier before removing or replacing any parts.

CAUTION: To help retard bacteria growth and keep maximum efficiency, the filter should be replaced at least once per season, or more often under hard water conditions. Use Sears recommended replacement filter.

To replace the filter in your Kenmore Quiet Comfort Whole House humidifier, follow the instructions below.

1. Unplug humidifier.

Before removing the filters, we recommend moving the humidifier to an area where floor coverings are not susceptible to water damage. (i.e. kitchen or bath areas.)

2. Remove the water bottle and set aside.
Be sure not to bump or damage the lower spring valve.

3. Grasp the housing assembly and lift straight up and away from the base and set aside. The filter is now accessible.

4. Take note of the filter position. Remove the filter and dispose of properly. You may want to clean the base at this time. See the "Cleaning Your Humidifier" section of this manual.

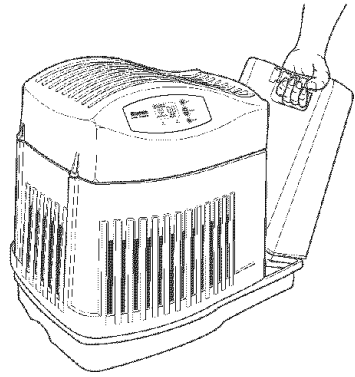

Grasp Housing Assembly Securely and Lift OFF

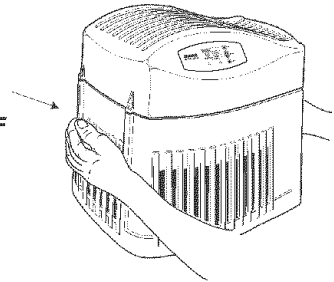

Filter

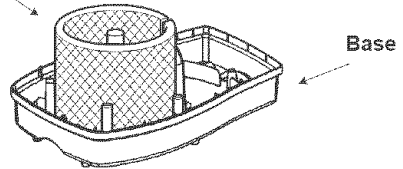

Replacement and Care of Filters (continued)

5. Install a new filter (42-14906) into the base. Coil the filter and position it between the uprights in the bottom of the base. The start and finish of the coil should be captured at the centre of the base (see diagram) and the filter should be resting on the floor of the base.
6. Return the housing assembly to the top of the base. Return the water bottle to the right of the housing assembly and reposition the humidifier to its operating position.
7. The humidifier is now ready to be filled for operation.

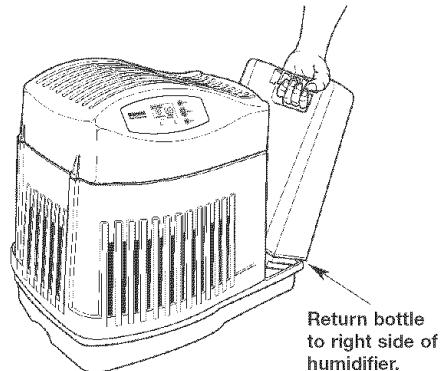
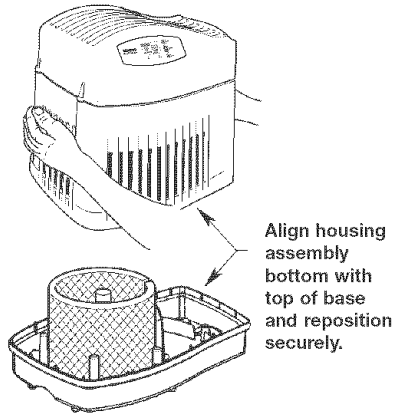
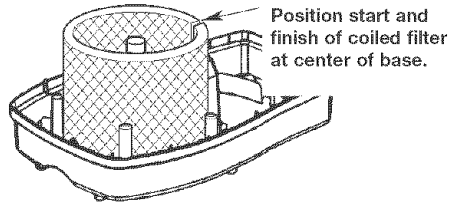
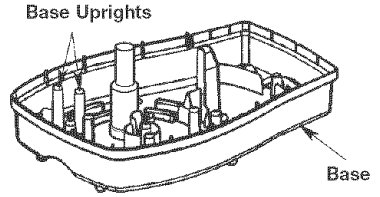

Cleaning Your Humidifier

WARNING: To reduce the risk of injury, fire or damage to humidifier, use only cleaners specifically recommended for humidifiers. Never use flammable, combustible or poisonous materials to clean your humidifier. To reduce the risk of scalds and damage to humidifier, never put hot water in humidifier.

CAUTION: Local water purity varies from area to area and under certain conditions water impurities and airborne bacteria may promote the growth of microorganisms in the reservoir of the humidifier.

To retard bacteria growth that may cause odors and be harmful to your health, use only Sears replacement filters. We also recommend using EPA approved bacteriostat, 42-14900 and humidifier cleaner 42-14713, available at your local Sears store.

Step 1

To make cleaning easier, the humidifier base should be empty and completely dried out. To accomplish this, use the following method:

- Allow the humidifier to run until the amber Refill light illuminates and the automatic shutoff has stopped the humidifier fan.
- Unplug humidifier.

WARNING: If humidifier is not unplugged, fan could start after housing is removed.

Step 2

To Remove Parts

- Remove the water bottle and set aside. Be sure not to bump or damage the lower spring valve.
- Grasp the housing assembly and lift straight up and away from the base and set aside. The filter is now accessible.
- Take note of the filter position. Remove the filter and set aside or dispose of properly.

NOTE: There may be a little water still in the base. Carefully dump the water out or remove with a sponge.

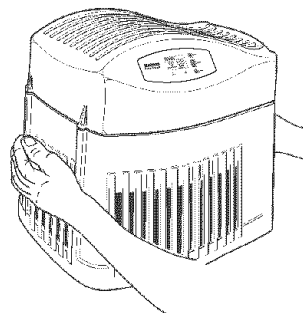

Note: Remove excess water before cleaning

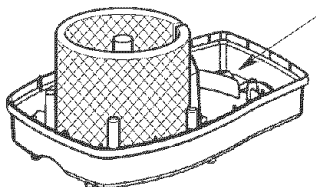

Cleaning of Humidifier (continued)

Step 3

Bi-Weekly Maintenance Removing Scale

1. Fill the humidifier base with one 8 oz. cup of undiluted white vinegar. Let solution stay 20 minutes.
2. Clean all interior surfaces with a soft brush. Dampen a soft cloth with undiluted white vinegar and wipe out the base to remove scale.
3. Rinse thoroughly with clean warm water to remove scale and cleaning solution.

Disinfecting Base

1. Pour 1 gallon of water and 1 teaspoon chlorine bleach into the base. Let solution stay for 20 minutes, carefully swishing every few minutes. Wet all surfaces normally exposed to water.
2. Empty base after 20 minutes. Rinse with water until bleach smell is gone. Allow unit to dry out completely.

NOTE: The water bottle should be cleaned in the same manner as the base. Rinse thoroughly with clean water after all steps are complete.

Step 4

Replacing Parts

1. Install a new filter (42-14906) or the filter previously set aside if it is in good condition into the base. Coil the filter and position it between the uprights in the bottom of the base. The start and finish of the coil should be captured in the centre of the base (see diagram) and the filter should be resting on the floor of the base.
2. Return the housing assembly to the top of the base. Return the water bottle to the right of the housing assembly and reposition the humidifier to its operating position.
3. The humidifier is now ready to be filled for operation.

End of Season Maintenance

1. Follow "Bi-Weekly Maintenance" instructions at end of humidification season.
2. Remove filter and dispose of properly.
3. Let humidifier dry completely before storing. Do not store with water inside base or bottle.
4. Store in cool, dry location.
5. Install a new filter in clean humidifier before next season begins.

Note: "Bi-Weekly Maintenance" is also recommended if you do not plan to run the humidifier for one week or more.

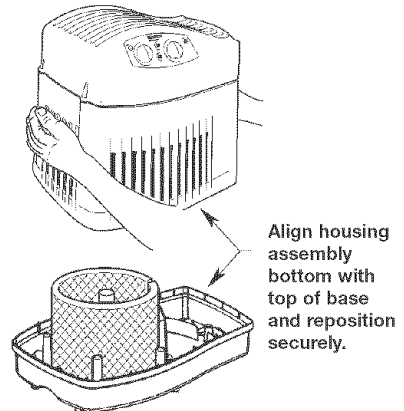
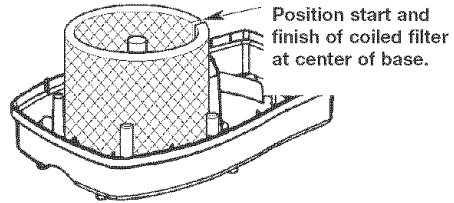

Troubleshooting

Trouble	Probable Cause	Remedy
Red power light and digital display not illuminated.	<ul style="list-style-type: none"> • No Power. • Power button has not been depressed. 	<ul style="list-style-type: none"> • Check 120 volt power source. • Press power button once to turn on.
Fan not operating (Red power light and digital display is illuminated).	<ul style="list-style-type: none"> • ROOM humidity level is 1% or more above SET humidity level. 	<ul style="list-style-type: none"> • Raise SET humidity level if desired.
Fan running continuously.	<ul style="list-style-type: none"> • SET humidity level is 65%. • ROOM humidity level is 3% or more below SET humidity level. • Humidifier under size for requirements. 	<ul style="list-style-type: none"> • A SET humidity percentage of 65% operates fan continuously. Adjust SET level between 30% - 60%. • Continue to run until desired humidity level is achieved. This may take up to 48 hours initially. • This unit is designed to satisfy an area up to 2,300 sq. ft.
Poor evaporation of water.	<ul style="list-style-type: none"> • CHECK FILTER message flashing. 	<ul style="list-style-type: none"> • Change to a fresh new filter.
Bottle empties completely.	<ul style="list-style-type: none"> • This is normal for initial filling. 	<ul style="list-style-type: none"> • Refill for maximum run time.
Bottle continues to empty after initial filling.	<ul style="list-style-type: none"> • Air is entering water bottle. 	<ul style="list-style-type: none"> • Ensure fill cap is tightened securely. • Ensure gasket on fill cap is in place. • Check for leak in water bottle.
Bottle not emptying.	<ul style="list-style-type: none"> • Spring Valve Assembly damaged or missing post in bottom of base. • Base full of water. 	<ul style="list-style-type: none"> • Check orientation of bottle. Reposition so that spring valve on bottom of bottle is depressed by post in bottom of base. • The base will hold the contents of water bottle (2.0 gallons). Continue to run humidifier to deplete water from base.

CAUTION: Use only 42-14900 EPA Registered Bacteriostat available from Sears Retail store.

Use of other water treatment products may damage the filter component.

Under no circumstances should you use water treatment products designed for Roto belt or Ultrasonic humidifiers.

Troubleshooting

Trouble	Probable Cause	Remedy
Display blinks or fan moves slightly when humidifier is plugged in.	<ul style="list-style-type: none"> • Normal 	<ul style="list-style-type: none"> • No action required.
"CHECK FILTER" message does not appear even when filter is dirty or humidifier performance is clearly reduced.	<ul style="list-style-type: none"> • Humidistat on power cord is being heated. 	<ul style="list-style-type: none"> • Move power cord away from any source of heat or obstruction.
Fan operating slower than speed registered on digital display.	<ul style="list-style-type: none"> • Humidifier in "DRY OUT MODE". 	<ul style="list-style-type: none"> • Humidifier automatically switches fan speed to "WHISPER" when "DRY OUT MODE" message is displayed.
Humidifier not shutting off during "DRY OUT MODE".	<ul style="list-style-type: none"> • Filter not dry. 	<ul style="list-style-type: none"> • During "DRY OUT MODE" the humidifier will continue to run on "WHISPER" speed as required for up to 2 hours or until the filter is completely dry.

CAUTION: Use only 42-14900 EPA Registered Bacteriostat available from Sears Retail store.

Use of other water treatment products may damage the filter component.

Under no circumstances should you use water treatment products designed for Roto belt or Ultrasonic humidifiers.

Repair Parts

Parts List for Sears Humidifier Model No. 758.144115

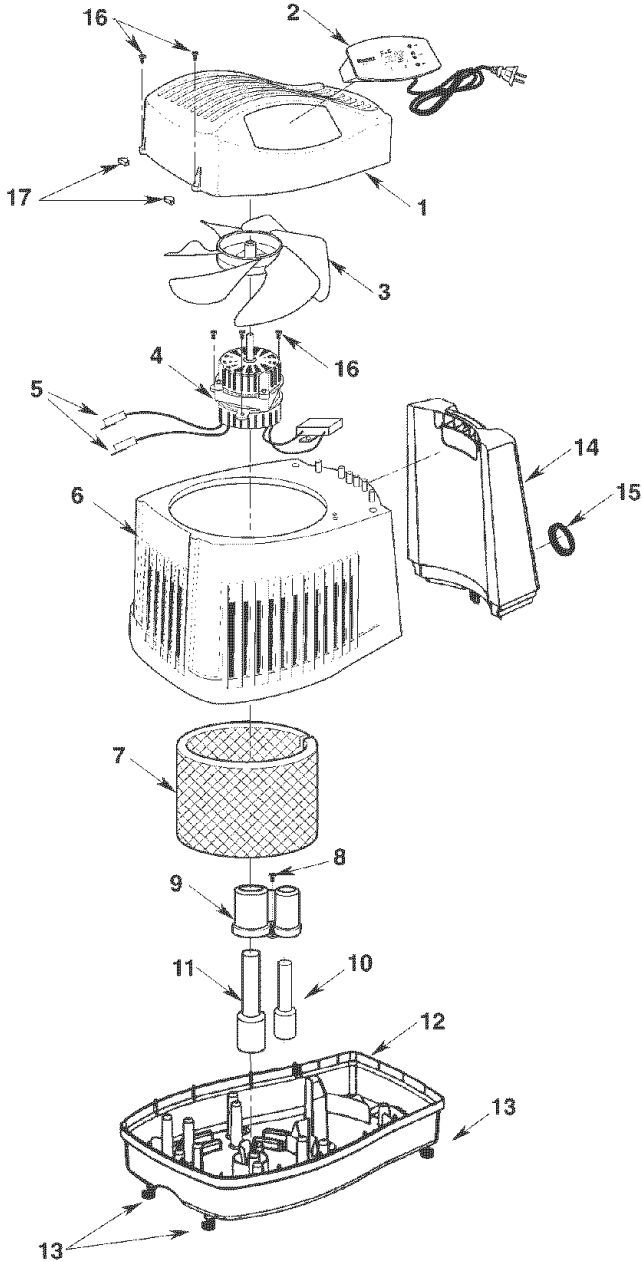

Repair Parts

Parts List for Sears Humidifier Model No. 758.144115

Always order by part number - Not by key number

Key No	Part No.	Description
1	830487	Housing, Upper
2	829825	• Assembly, Control
3	829821	• Blade, Fan
4	829819	• Motor
5	828854	Switch, Micro
6	830489	Housing, Lower
7	42-14906	† Filter
8	829815	Screw, Pan Hd. Ty. AB #6 x 1/2 SS
9	830496	Support, Filter
10	829813	Float, Bottle
11	829816	Float, Reservoir
12	830484	Base
13	829812	Casters (Includes 4)
14	830537	Bottle, Includes Key # 15
15	824690-2	Cap, Fill
16	829805	Screw, Pan Hd. Trx Hi-Lo #6 x 3/4
17	830587	Cap, Screw
18	SP6520	Owner's Manual (not shown)

* Standard Hardware Item - May be purchased locally

† Stock item - May be secured through the Hardware Department of most Sears retail stores.

For the repair or replacement parts you need

Call 7 am - 7 pm, 7 days a week

1-800-366-PART

(1-800-366-7278)

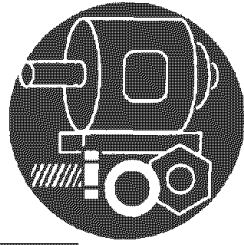

For in-home major brand repair service

Call 24 hours a day, 7 days a week

1-800-4-REPAIR

(1-800-473-7247)



For the location of a Sears Repair Service
Center in your area

Call 24 hours a day, 7 days a week

1-800-488-1222

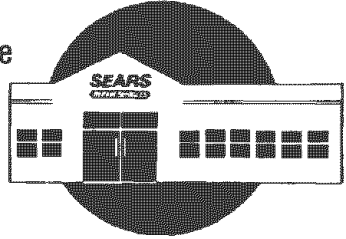

For information on purchasing a Sears
Maintenance Agreement or to inquire
about an existing Agreement

Call 9 am - 5 pm, Monday-Saturday

1-800-827-6655

SEARS
REPAIR SERVICES

America's Repair Specialists



The model number will be found on the Humidifier identification label.

When requesting service or ordering parts, always provide the following information:

- Product Type
- Model Number
- Part Number
- Part Description