

Operating Guide | Warranty

Model Numbers | C27V22 | C32V22 | C36V22 | HDTV Monitors

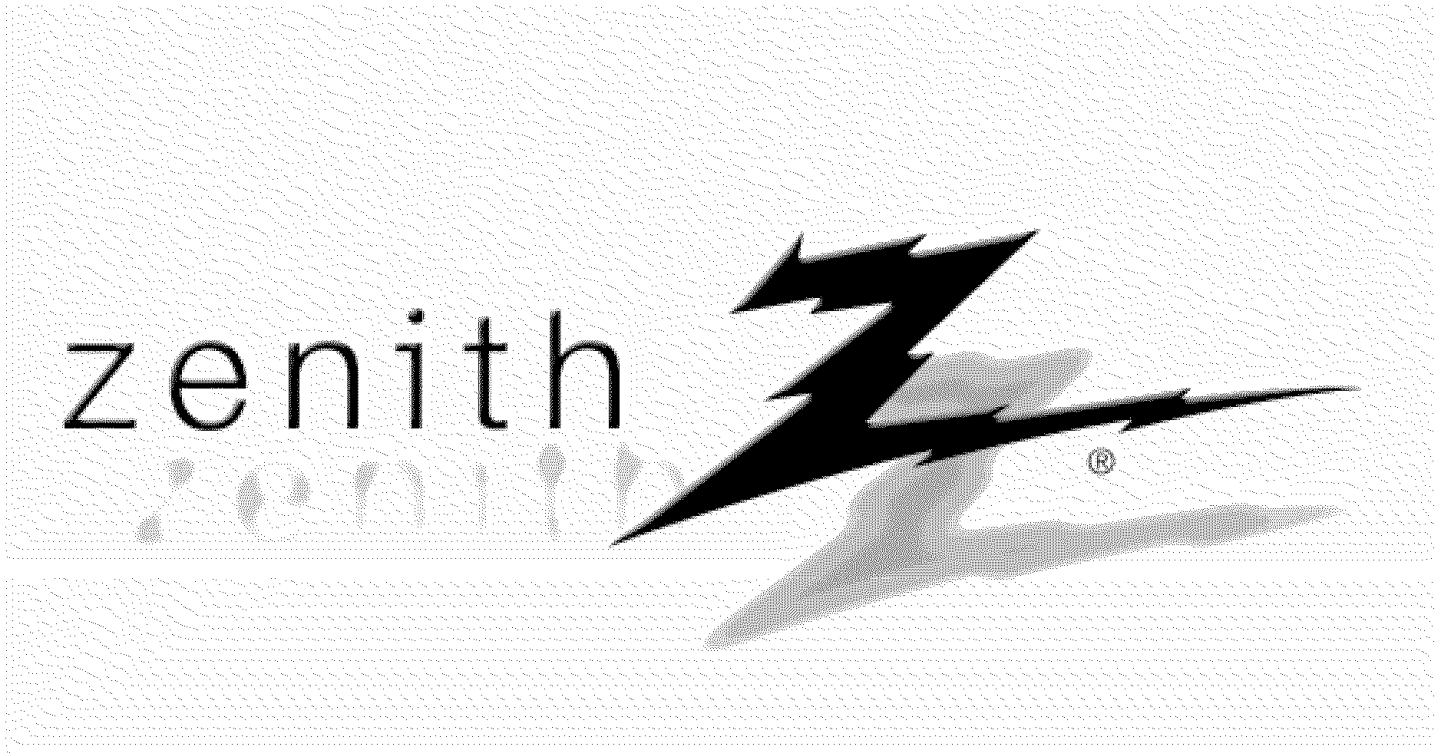

RECORD YOUR MODEL NUMBER

The model and serial number of your Entertainment Machine™ are located on the back of the TV cabinet. For your future convenience, we suggest that you record these numbers here:

Model No. _____

Serial No. _____

WARNING:

TO REDUCE THE RISK OF ELECTRIC SHOCK DO NOT REMOVE COVER (OR BACK). NO USER SERVICEABLE PARTS INSIDE. REFER SERVICING TO QUALIFIED SERVICE PERSONNEL.

The lightning flash with arrowhead symbol, within an equilateral triangle, is intended to alert the user to the presence of uninsulated "dangerous voltage" within the product's enclosure that may be of sufficient magnitude to constitute a risk of electric shock to persons.

The exclamation point within an equilateral triangle is intended to alert the user to the presence of important operating and maintenance (servicing) instructions in the literature accompanying the appliance.

WARNING:

TO PREVENT FIRE OR SHOCK HAZARDS, DO NOT EXPOSE THIS PRODUCT TO RAIN OR MOISTURE.

POWER CORD POLARIZATION:

CAUTION: To prevent electric shock, match wide blade of plug to wide slot, fully insert.

ATTENTION: P

correspondante de la prise et pousser jusqu'au fond.

NOTE TO CABLE/TV INSTALLER:

This reminder is provided to call the cable TV system installer's attention to Article 820-40 of the National Electric Code (U.S.A.). The code provides guidelines for proper grounding and, in particular, specifies that the cable ground shall be connected to the grounding system of the building, as close to the point of the cable entry as practical.

REGULATORY INFORMATION:

This equipment has been tested and found to comply with the limits for a Class B digital device, pursuant to Part 15 of the FCC Rules. These limits are designed to provide reasonable protection against harmful interference when the equipment is operated in a residential installation. This equipment generates, uses and can radiate radio frequency energy and, if not installed and used in accordance with the instruction manual, may cause harmful interference to radio communications. However, there is no guarantee that interference will not occur in a particular installation. If this equipment does cause harmful interference to radio or television reception, which can be determined by turning the equipment off and on, the user is encouraged to try to correct the interference by one or more of the following measures:

- Reorient or relocate the receiving antenna.
- Increase the separation between the equipment and receiver.
- Connect the equipment into an outlet on a circuit different from that to which the receiver is connected.
- Consult the dealer or an experienced radio/TV technician for help.

CAUTION:

Do not attempt to modify this product in any way without written authorization from Zenith Electronics Corporation. Unauthorized modification could void the user's authority to operate this product.

COMPLIANCE:

The responsible party for this product's compliance is:
Zenith Electronics Corporation, 2000 Millbrook Drive, Lincolnshire, IL 60069, USA • Phone: 1-847-941-8000.

IMPORTANT SAFETY INSTRUCTIONS

Important safeguards for you and your new product

Your product has been manufactured and tested with your safety in mind. However, improper use can result in potential electrical shock or fire hazards. To avoid defeating the safeguards that have been built into your new product, please read and observe the following safety points when installing and using your new product, and save them for future reference.

Observing the simple precautions discussed in this operating guide can help you get many years of enjoyment and safe operation that are built into your new product.

This product complies with all applicable U.S. Federal safety requirements, and those of the Canadian Standards Association.

1. Read Instructions

All the safety and operating instructions should be read before the product is operated.

2. Follow Instructions

All operating and use instructions should be followed.

3. Retain Instructions

The safety and operating instructions should be retained for future reference.

4. Heed Warnings

All warnings on the product and in the operating instructions should be adhered to.

5. Cleaning

Unplug this product from the wall outlet before cleaning. Do not use liquid cleaners or aerosol cleaners. Use a damp cloth for cleaning.

6. Water and Moisture

Do not use this product near water for example, near a bath tub, wash bowl, kitchen sink, or laundry tub, in a wet basement, or near a swimming pool.

7. Accessories, Carts, and Stands

Do not place this product on a slippery or tilted surface, or on an unstable cart, stand, tripod, bracket, or table. The product may slide or fall, causing serious injury to a child or adult, and serious damage to the product. Use only with a cart, stand, tripod, bracket, or table recommended by the manufacturer, or sold with the product. Any mounting of the product should follow the manufacturer's instructions, and should use a mounting accessory recommended by the manufacturer.

8. Transporting Product

A product and cart combination should be moved with care. Quick stops, excessive force, and uneven surfaces may cause the product and cart combination to overturn.



PORTABLE CART WARNING

9. Attachments

Do not use attachments not recommended by the product manufacturer as they may cause hazards.

10. Ventilation

Slots and openings in the cabinet are provided for ventilation and to ensure reliable operation of the product and to protect it from overheating, and these openings must not be blocked or covered. The openings should never be blocked by placing the product on a bed, sofa, rug, or other similar surface. This product should not be placed in a built-in installation such as a bookcase or rack unless proper ventilation is provided or the manufacturer's instructions have been adhered to.

11. Power Sources

This product should be operated only from the type of power source indicated on the marking label. If you are not sure of the type of power supply to your home, consult your product dealer or local power company. For products intended to operate from battery power, or other sources, refer to the operating instructions.

12. Power Cord Polarization

This product is equipped with a polarized alternating - current power plug (a plug having one blade wider than the other). This plug will fit into the power outlet only one way. This is a safety feature. If you are unable to insert the plug fully into the outlet, try reversing the plug. If the plug should still fail to fit, contact your electrician to replace your obsolete outlet. Do not defeat the safety purpose of the polarized plug.

13. Power Cord Protection

Power-supply cords should be routed so that they are not likely to be walked on or pinched by items placed upon or against them, paying particular attention to cords at plugs, convenience receptacles, and the point where they exit from the product.

(Continued on next page)

IMPORTANT SAFETY INSTRUCTIONS

(Continued from previous page)

14. Outdoor Antenna Grounding

If an outside antenna or cable system is connected to the product, be sure the antenna or cable system is grounded so as to provide some protection against voltage surges and built-up static charges. Article 810 of the National Electrical Code (U.S.A.), ANSI/ NFPA 70 provides information with regard to proper grounding of the mast and supporting structure, grounding of the lead-in wire to an antenna discharge unit, size of grounding conductor, antenna-discharge unit, connection to grounding electrodes, and requirements for the grounding electrode.

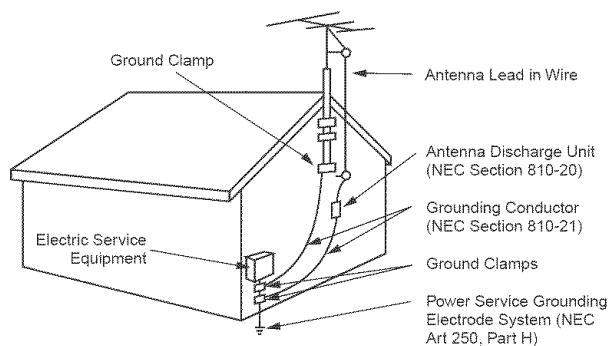

NEC - National Electrical Code

15. Lightning

For added protection for this product (receiver) during a lightning storm, or when it is left unattended and unused for long periods of time, unplug it from the wall outlet and disconnect the antenna or cable system. This will prevent damage to the product due to lightning and power-line surges.

16. Power Lines

An outside antenna system should not be located in the vicinity of overhead power lines or other electric light or power circuits, or where it can fall into such power lines or circuits. When installing an outside antenna system, extreme care should be taken to keep from touching such power lines or circuits as contact with them might be fatal.

17. Overloading

Do not overload wall outlets and extension cords as this can result in a risk of fire or electric shock.

18. Object and Liquid Entry

Never push objects of any kind into this product through openings as they may touch dangerous voltage points or

short-out parts that could result in a fire or electric shock. Never spill liquid of any kind on the product.

19. Servicing

Do not attempt to service this product yourself as opening or removing covers may expose you to dangerous voltage or other hazards. Refer all servicing to qualified service personnel.

20. Damage Requiring Service

Unplug this product from the wall outlet and refer servicing to qualified service personnel under the following conditions:

- If the power-supply cord or plug is damaged.
- If liquid has been spilled, or objects have fallen into the product.
- If the product has been exposed to rain or water.
- If the product does not operate normally by following the operating instructions. Adjust only those controls that are covered by the operating instructions as an improper adjustment of other controls may result in damage and will often require extensive work by a qualified technician to restore the product to its normal operation.
- If the product has been dropped or the cabinet has been damaged.
- If the product exhibits a distinct change in performance.

21. Replacement Parts

When replacement parts are required, be sure the service technician has used replacement parts specified by the manufacturer or have the same characteristics as the original part. Unauthorized substitutions may result in fire, electric shock, or other hazards.

22. Safety Check

Upon completion of any service or repairs to this product, ask the service technician to perform safety checks to determine that the product is in proper operating condition.

23. Wall or Ceiling Mounting

The product should be mounted to a wall or ceiling only as recommended by the manufacturer. The product may slide or fall, causing serious injury to a child or adult, and serious damage to the product.

24. Heat

The product should be situated away from heat sources such as radiators, heat registers, stoves, or other products (including amplifiers) that produce heat.

Table of Contents

Refer to the information below to hook up external equipment and set up the features on your Entertainment Machine

Step 1. Hook up external equipment and antenna or cable service wires to the TV. Install batteries in the remote control. After all connections have been made, plug your TV into standard household power, see pages 7 thru 14.

Step 2. Go to page 18 to EZ program the TV.

Step 3. Set up all other TV options see pages listed below.

Safety Warnings	2	Video Menu	29
Important Safety Information	3 - 4	Contrast, Brightness, Color, Tint, Sharpness, Color Temp:	(Cool, Warm), EZ Picture: (Custom, Normal, Movie, Digital Pres, Video Game, Sports, Night Time, Weak Signal).
Table of Contents	5	Video Sub Menu, Aspect Ratio and other settings	30
Step 1. Hook Up TV		Audio Menu	31
Connection Panel Overview	6	Bass, Treble, Balance, Audio Mode: (Stereo, Mono, SAP), EZ Bass Front Surround, EZ SoundRite, Speakers, EZ Sound: (Custom, Normal, Stadium, News, Music, Theater).	
Equipment Connection Options		Lock (Parental Control Menu)	32 - 33 - 34
Antenna, Install batteries in remote control	7	Restricts viewer programming.	
Cable Service, Install batteries in remote control	8	Special Menu	
Antenna with VCR, Install batteries in remote control	9	EZ Timer: Sleep Timer	35
Cable Service with VCR, Install batteries in remote control	10	EZ Timer: On/Off Timer Functions	36
S-VHS VCR, Install batteries in remote control	11	Channel Labels	37
DVD Component Video Hookup	12	XDS Display	38
High-Definition Hookup	13	PIP Menu (Setup PIP picture appearance)	39
High-Definition/RGB Hookup	14	Source Sense	40
Audio/Video Signal Output	15	Source Hookup Options	41
Front Panel Controls/Inputs	16	EZ Demo (On-screen menus overview)	42
Remote Control Key Functions in TV mode	17	PIP (Picture-in-Picture)	43 - 44
Step 2. Reception Setup and Channel Search		Remote Control Programming	
EZ Program: Select Cable service or Air Antenna and run channel search	18	Set up remote to operate other devices	45
On-Screen Menu Operation with Remote	19	Amplifier Volume Override	46
On-Screen Menus/Displays Overview	20 - 21	Aux 1 -2 -3	47
Other Functions and On-Screen Displays	22	AutoFind	48
Step 3. Customize the TV's Features		Programming Product Brand Codes	49 - 50
Setup Menu (Start with page 18, EZ Program)		Remote Modes Key Functions	51
Add/Del/Surf	23	Maintenance	52
EZ Clock Set	24	Troubleshooting	53 - 54 - 55
Captions (Caption/Text)	25	Glossary	56
Language	26	Notes	57 - 58 - 59
Source	27	Zenith Warranty	Back Cover
Background	28		

Note: Design and specifications are subject to change without prior notice.

"Source" Connection Panel Overview

To hook up source equipment, see below and also refer to the Table of Contents on page 5; shows pages to go to for equipment hookup options. Also, see the front connections panel source's hookup options on page 16.

After you have finished hooking up your source equipment, go to page 18 and use EZ Program to search for and find all the available channels in your area.

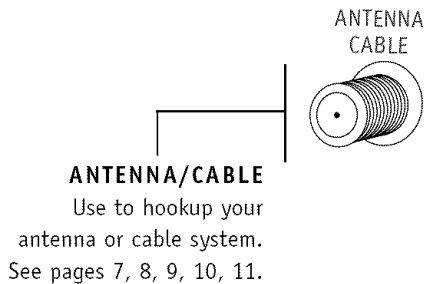
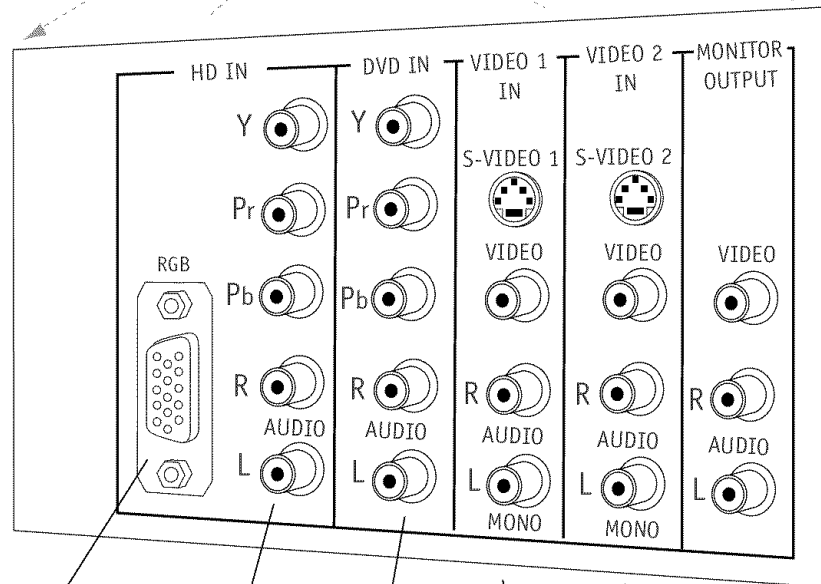
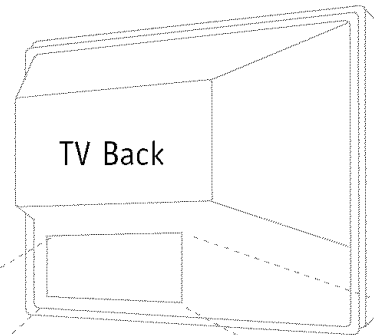

ANTENNA/CABLE
Use to hookup your antenna or cable system.
See pages 7, 8, 9, 10, 11.

HD-RGB INPUT

Connect HD-RGB here.

RGB Format: EDTV Set top Box 640 x 480p
RGB Format: HDTV Set top Box 1920 x 1080i

HD IN

Connect progressive scan or high-definition component video equipment here.

Progressive Scan DVD, 480p
EDTV Set top Box, 480p
HDTV Set top Box, 1080i

DVD IN

Connect a standard component video equipment or DVD player here.

DVD Player, 480i
SDTV Set top Box, 480i

VIDEO 1 IN VIDEO 2 IN

Connect your Audio/Video or S-Video equipment to these jacks.

See pages 9, 10, 11.

VIDEO / R - L AUDIO OUT

Use these output jacks to connect external audio/video equipment.

See page 15.

Hook Up an Off-Air Antenna

Connect an off-air antenna

- 1** Locate the Antenna/Cable jack on the back of your Entertainment Machine.
- 2** Connect the wire that runs from the wall directly to this jack, according to one of the diagrams to the right.
- 3** Remove the back of the remote and put in two "AAA" batteries.

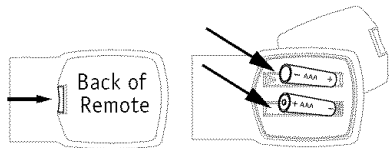

- 4** Plug in your TV. Do not plug it into an outlet controlled by a switch. Your Entertainment Machine is designed to operate on standard household current, 120-volt 60 Hertz AC. Do not attempt to operate it on DC power.

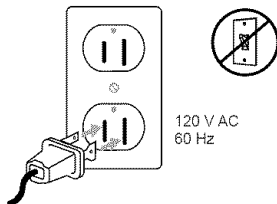

If you have a 75 ohm RF cable, then you don't need any adapters!



A 300 to 75 ohm adapter is not included with the TV.

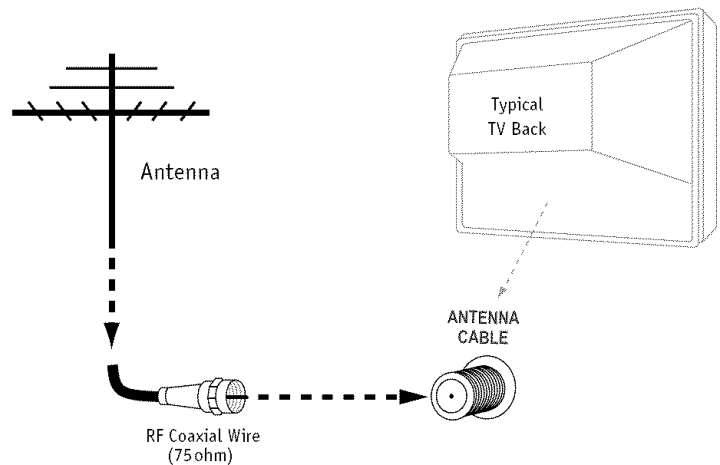
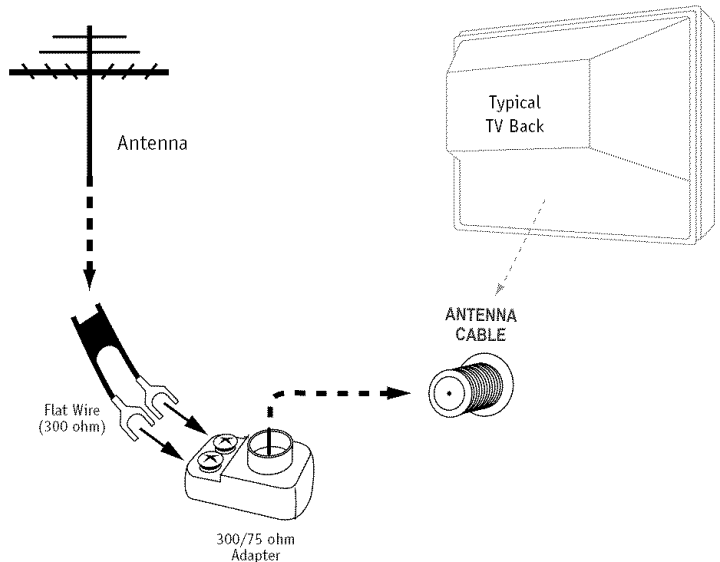

Mini glossary

- 75 OHM RF CABLE** The wire that comes from an off-air antenna or cable service provider. Each end looks like a hex shaped nut with a wire sticking through the middle, and it screws onto the threaded jack on the back of your TV.
- 300 TO 75 OHM ADAPTER** A small device that connects a two-wire 300 ohm antenna to a 75 ohm RF jack. They are usually about an inch long with two screws on one end and a round opening with a wire sticking out on the other end.

Hook Up Cable Service (CATV)

Connect cable service to your Entertainment Machine

- 1 Locate the Antenna/Cable jack on the back of the TV.
- 2 Connect the cable service wire that runs from the wall or cable box directly to this jack, according to one of the diagrams to the right.
- 3 Remove the back of the remote and put in two "AAA" batteries.

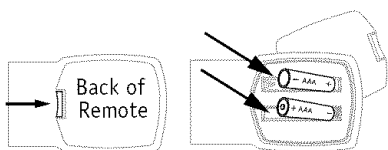

- 4 Plug in the TV. Do not plug it into an outlet controlled by a switch. Your TV is designed to operate on standard household current, 120-volt 60 Hertz AC. Do not attempt to operate it on DC power.

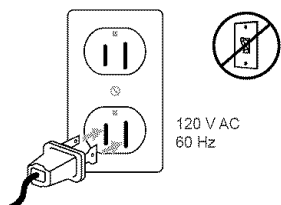

If you're using a cable box, leave the TV on channel 3 or 4 and use your cable box to change channels.



If you're using a cable box, EZ Program might only find the channel your cable service is on (usually channel 3 or 4). Don't worry, that's all you need!

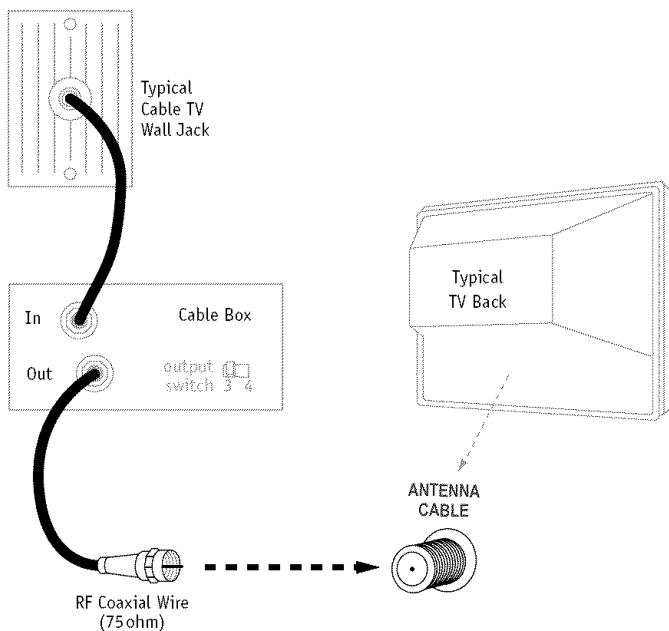
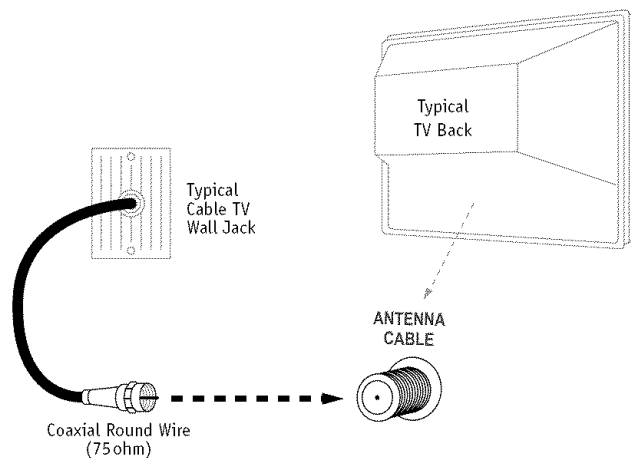

Hook Up an Off-Air Antenna and VCR

Connect your off-air antenna and VCR to your Entertainment Machine

1 Locate the Antenna In jack on the back of the VCR.

2 Connect the wire that runs from the antenna, according to the diagram to the right. Make any other connections as necessary.

3 Remove the back of the remote and put in two "AAA" batteries.

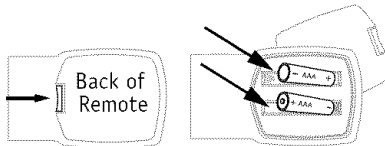

4

Plug in the TV. Do not plug it into an outlet controlled by a switch. The TV is designed to operate on standard current, 120-volt 60 Hertz AC. Do not attempt to operate it on DC power.

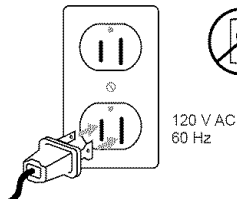

No adapters or A/V cables are included with the TV. See your Zenith dealer to purchase any adapters or cables.



Without A/V cables, most VCRs will not play videocassettes in stereo sound.

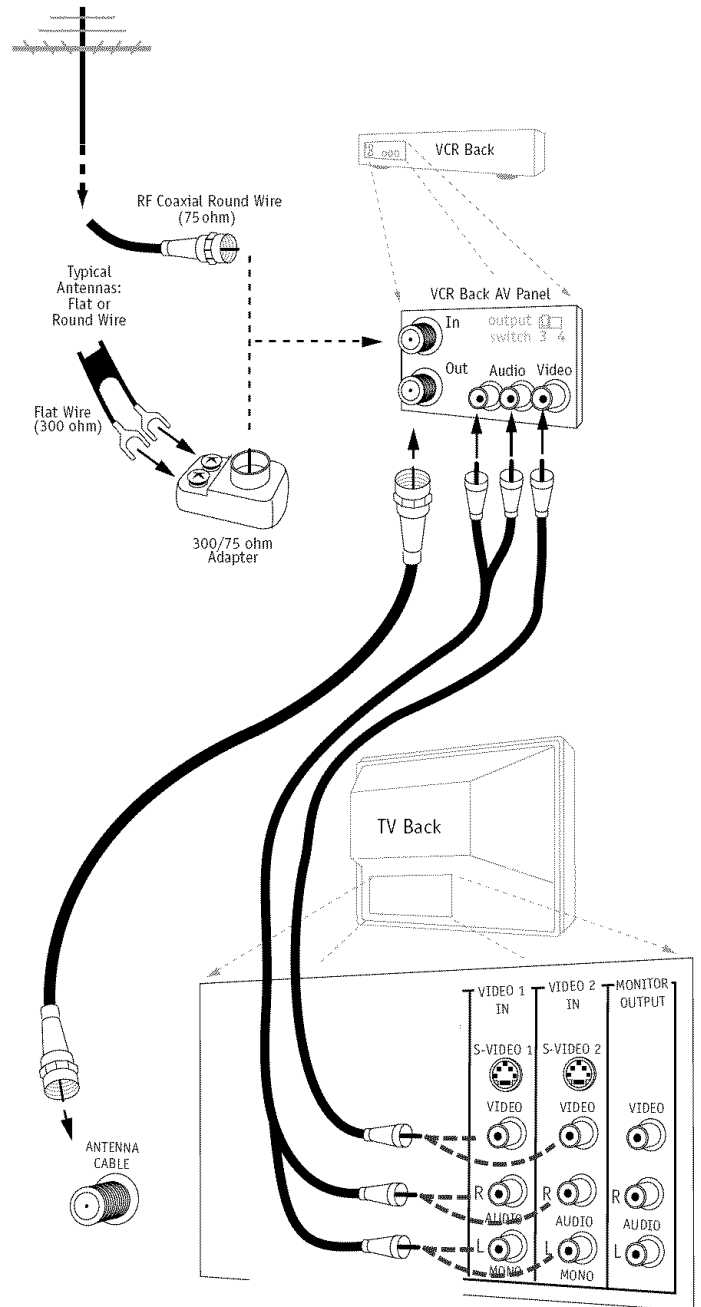

Connect your VCR to the Video 1 or Video 2 set of input jacks

Hook Up Cable Service (CATV) and VCR

Connect Cable service and a VCR to the TV

- 1** Locate the Antenna/Cable In jack on the back of the VCR.
- 2** Connect the cable service wire that runs from the wall, according to one of the diagrams to the right. Make any other connections necessary for your setup.
- 3** Remove the back of the remote and put in two "AAA" batteries.

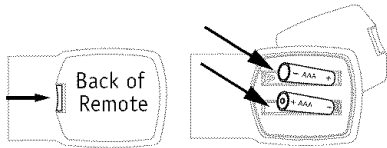

- 4** Plug in the TV. Do not plug it into an outlet controlled by a switch. The TV is designed to operate on standard current, 120-volt 60 Hertz AC. Do not attempt to operate it on DC power.

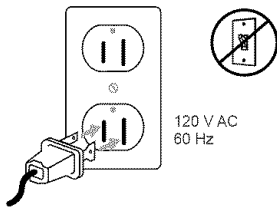

 Tune both the VCR and the television to channel 3 or 4 (cable box output channel) and use the cable box to change channels.

 No A/V cables are included with your TV. Without A/V cable hookups, most VCRs will not play videocassettes in stereo sound.

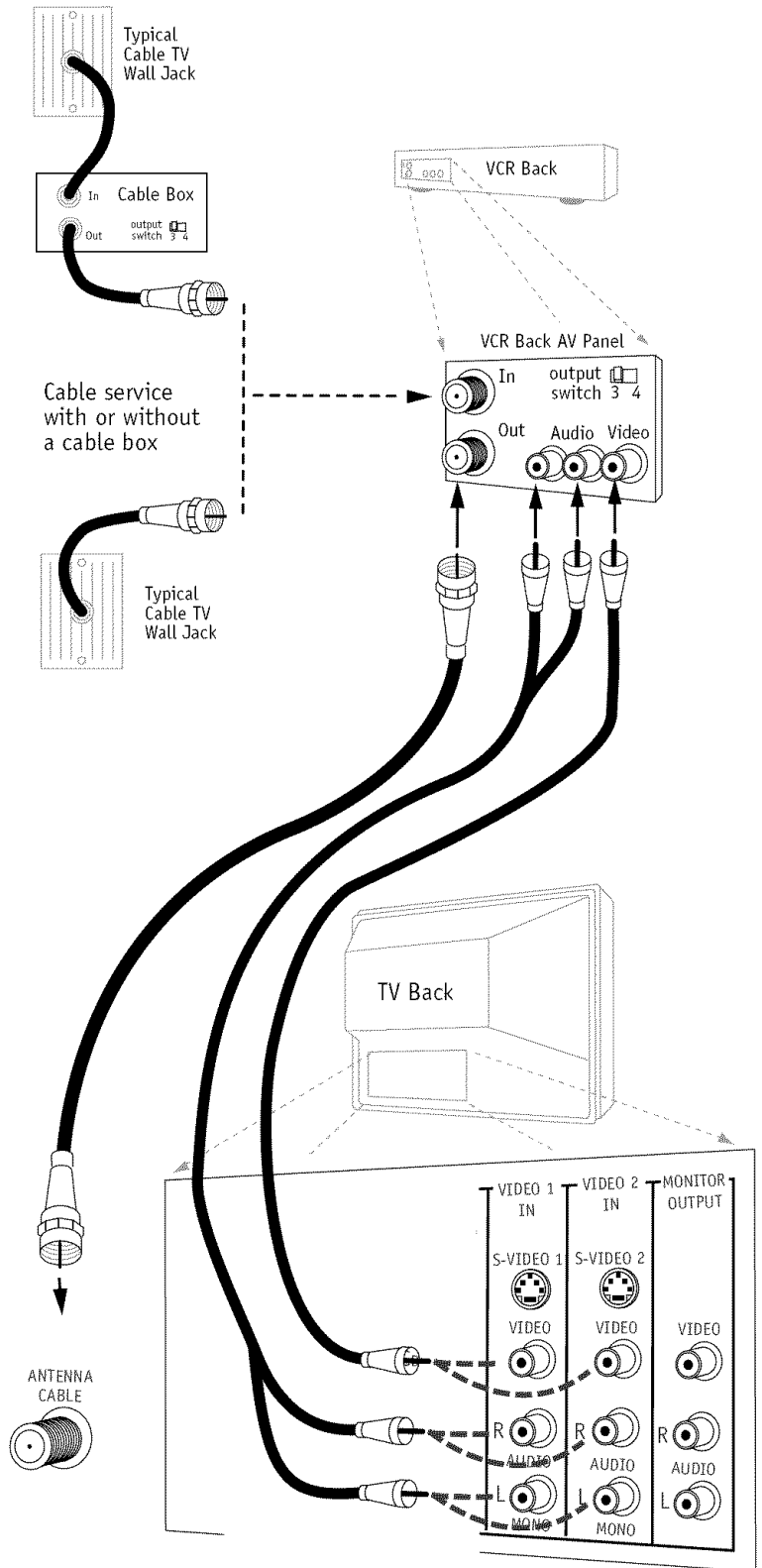

Connect your VCR to the Video 1 or Video 2 set of input jacks

Hook Up S-VHS VCR

Your Zenith TV may be connected to a Super-VHS VCR through the S-Video Input located on the front or rear source connection panels on your TV

1 Hook up your S-VHS VCR to your Zenith TV according to the diagram shown at the right.

2 Remove the back of the remote and put in two "AAA" batteries.

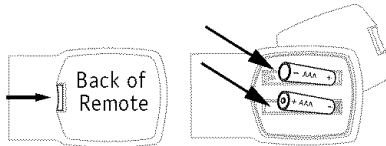

3 Plug in your TV. Do not plug it into a switched outlet. Your Zenith TV is designed to operate on standard household current, 120-volt 60 Hertz AC. Do not attempt to operate it on DC power.

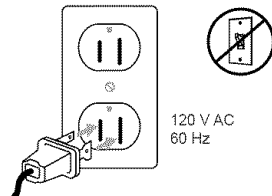

4 On the remote, press SOURCE repeatedly until "S-Video" is displayed. Or use the Source menu to choose the S-Video input the equipment is connected to.

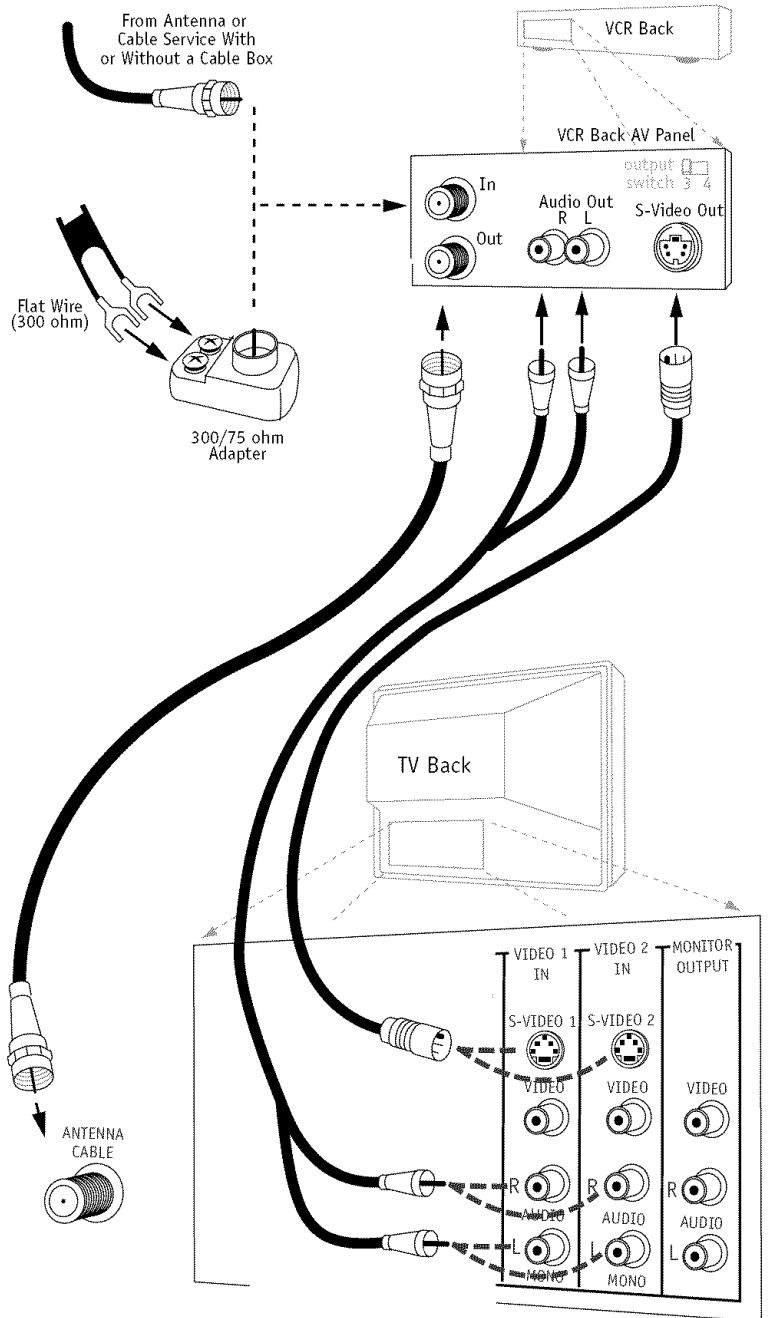

Connect your S-Video VCR to the S-Video 1 or S-Video 2 set of input jacks

Hook Up Component Video Equipment

Connecting component video DVD equipment

DVD IN

Connect a standard component video equipment or DVD player to DVD IN.
DVD Player, 480i
SDTV Set top Box, 480i

- 1 Make the connections as indicated. (Appearance of components may vary from those in the illustrations.)
- 2 Plug in your TV. Do not plug it into a switched outlet. Your Entertainment Machine is designed to operate on standard household current, 120-volt 60 Hertz AC. Do not attempt to operate it on DC power.

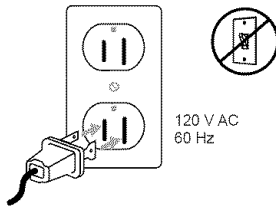

- 3 Press POWER to turn TV on.
- 4 On the remote, press SOURCE repeatedly until "DVD" is displayed. Or use the Source menu to choose DVD.



Component video jacks are sometimes labeled with Cr, Cb, or Pb, Pr. In this case, connect B to B and the R to R. The "Y" jack is usually labeled "Y", connect Y to Y.

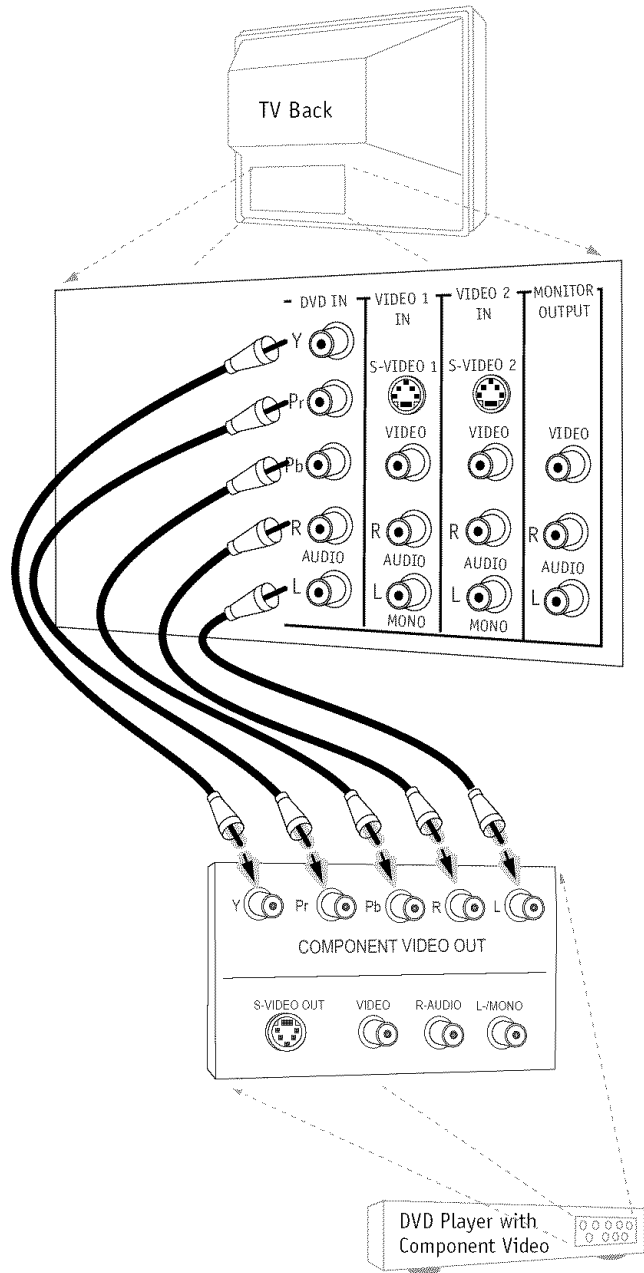

DVD Player with
Component Video

Hook Up HD Equipment

Connecting high-definition equipment

HD IN

Connect progressive scan or high-definition component video equipment to HD IN.
Progressive Scan DVD, 480p
EDTV Set top Box, 480p
HDTV Set top Box, 1080i

1 Make the HD connections as indicated.
(Appearance of components may vary from those in the illustrations.)

2 Plug in your TV. Do not plug it into a switched outlet. Your Entertainment Machine is designed to operate on standard household current, 120-volt 60 Hertz AC. Do not attempt to operate it on DC power.

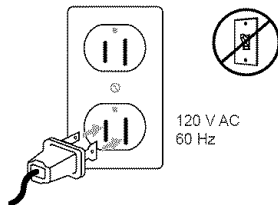

3 Press POWER to turn TV on.

4 On the remote, press SOURCE repeatedly until "HD-In" is displayed. Or use the Source menu to choose HD-In.

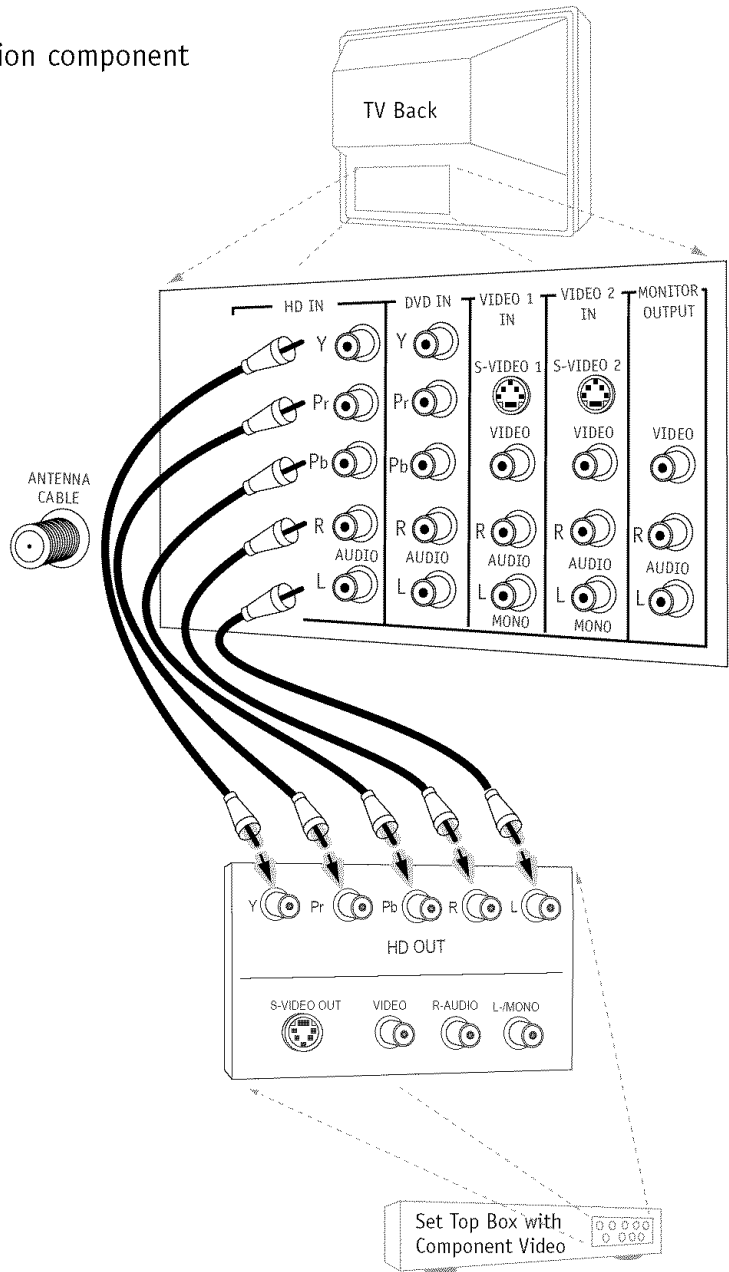

Hook Up HD-RGB Equipment

Connecting High-definition RGB output equipment

HD-RGB INPUT

Connect HD-RGB equipment here.

RGB Format: EDTV Set top Box 640 x 480p

RGB Format: HDTV Set top Box 1920 x 1080i

1 Make the RGB connections as indicated.
(Appearance of components may vary from those in the illustrations.)

2 Plug in your TV. Do not plug it into a switched outlet. Your Entertainment Machine is designed to operate on standard household current, 120-volt 60 Hertz AC. Do not attempt to operate it on DC power.

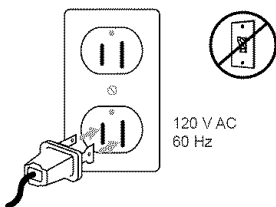

3 Press POWER to turn TV on.

4 On the remote, press SOURCE repeatedly until "HD-RGB In" is displayed. Or use the Source menu to choose HD-RGB In.

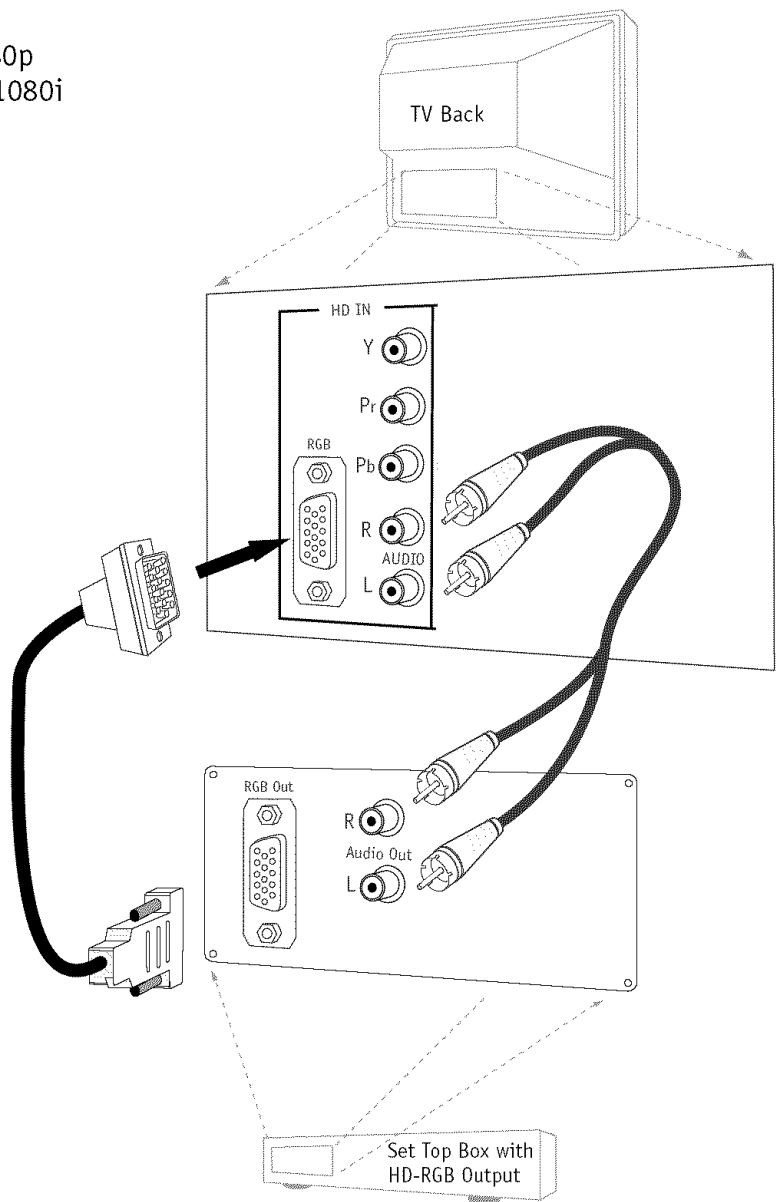

Audio/Video Signal Output

Output to Audio/Video devices

Make the Audio/Video Output connections as indicated. (Appearance of devices may vary from those in the illustrations.)

1

Video Output

Use the Video Out jack to connect to an external video device.

2

Audio Output

Use the Left and Right Audio Out jacks to connect an external amplifier and speakers. (Refer to the Audio Menu on page 31 for instructions on how to turn the TV's internal speakers off and on.)

3

Select Audio/Video Input on the external device to see the image and hear the sound from the TV.

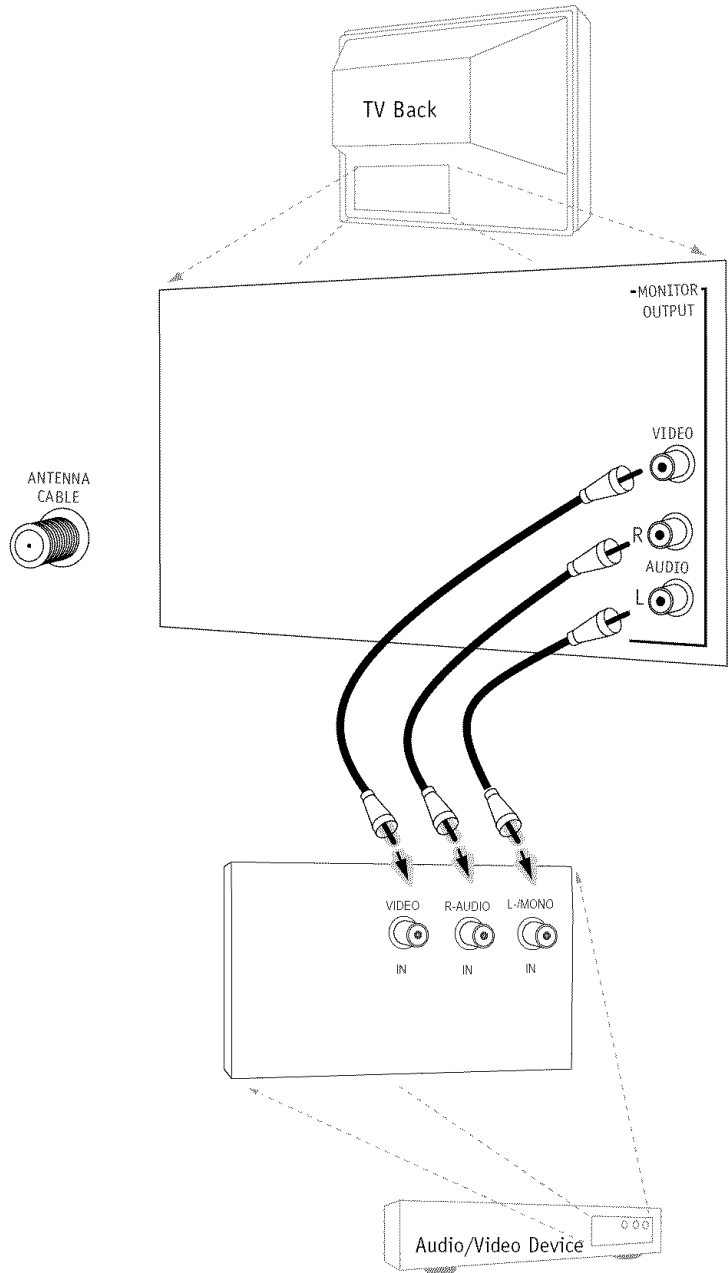

Front Panel Controls/Inputs

Using the front panel to operate the TV's basic features and to make temporary connections

Menu Operation

- 1 Press MENU to place menus on-screen.
- 2 Use Channel Up/Down to select menu option.
- 3 Use Volume Left/Right to adjust menu option.
- 4 Use MENU to remove menus from screen.

TV Operation

- 1 Press POWER to turn TV on and off.
- 2 Use the CHANNEL Up/Down buttons to select the next higher/lower channel number
- 3 Use the VOLUME Up/Down buttons to adjust the sound level louder or quieter to your preference.

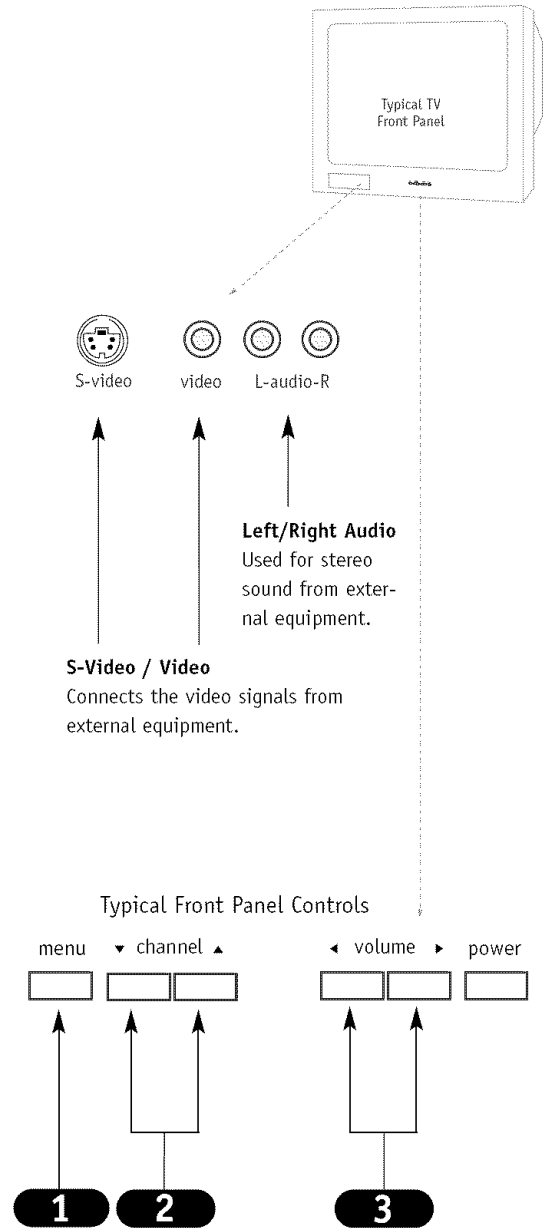

TV Mode Remote Key Functions

Note: Pressing TV puts remote into TV operating mode

A quick list of the keys on your remote and what they do in TV mode, see page 44 for remote key functions in the 6 additional programmable modes...

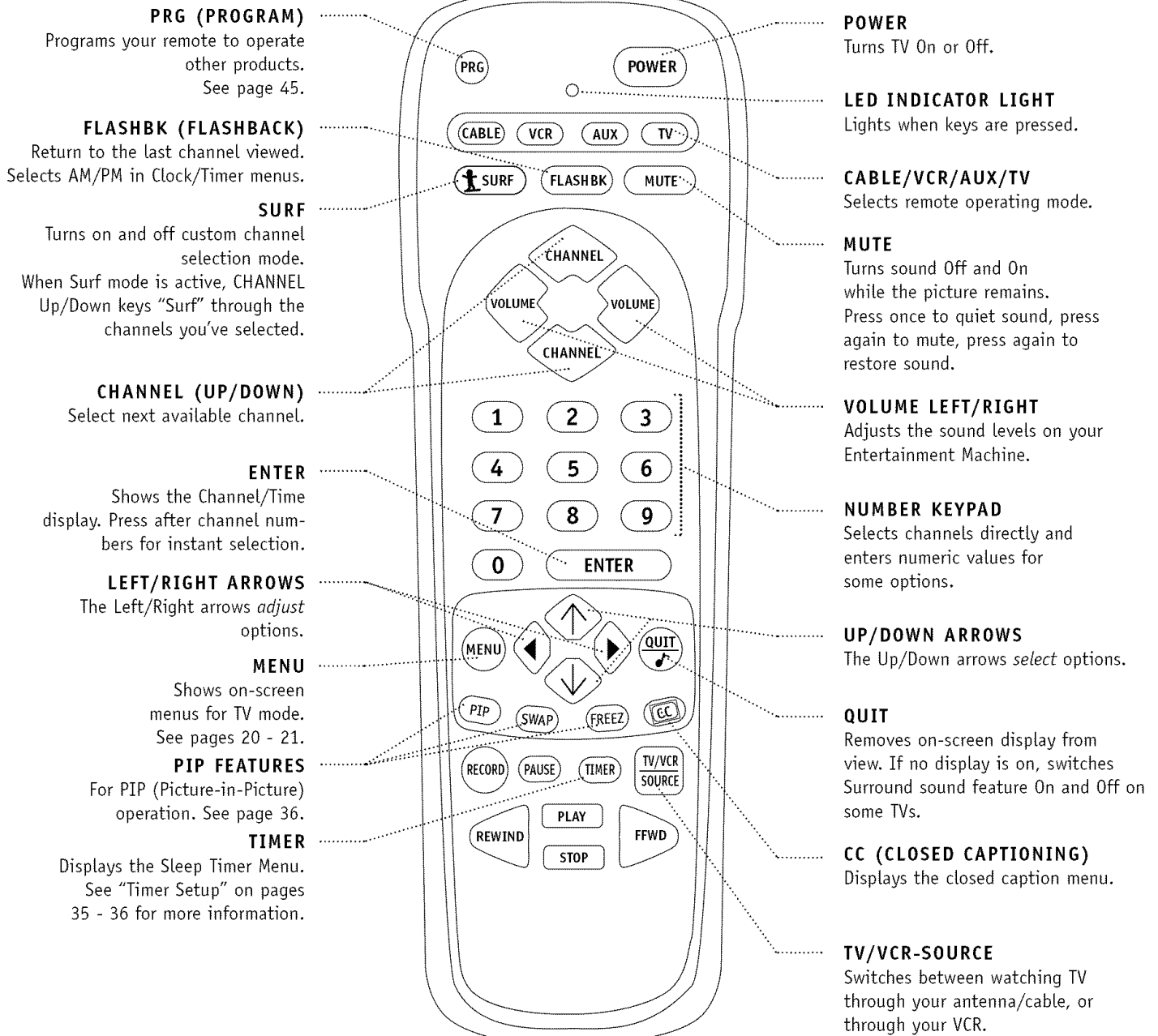

Keys dedicated to VCR functions will still operate your VCR while the remote is in TV mode.

remote control part number
MBR3457CT
(124-233-05)

EZ Program (Channel Search)

Use EZ Program to automatically find and store in the TV's memory, all the channels in your area

Select:

CABLE TV, If you subscribe to a cable service.

AIR ANTENNA, If you receive over-the-air programs.

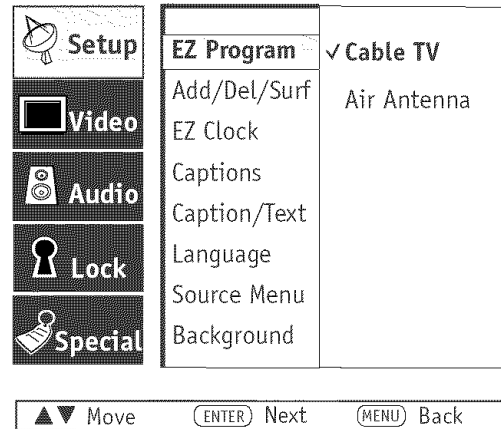

- 1** Press MENU, (if not selected, use the Up/Down arrow to choose Setup Menu,) then press ENTER.
- 2** Using the Up or Down arrow on the remote control, select EZ Program on your screen, then press ENTER.
- 3** Using the Up or Down arrow, select either Cable TV or Air Antenna, on your screen.
- 4** Press ENTER to begin the channel search.
- 5** When the channel search is complete, press MENU repeatedly until all menus are removed, or press QUIT.



EZ Program finds channels being received by the TV tuner.



Cable will not work unless you subscribe to a cable service.

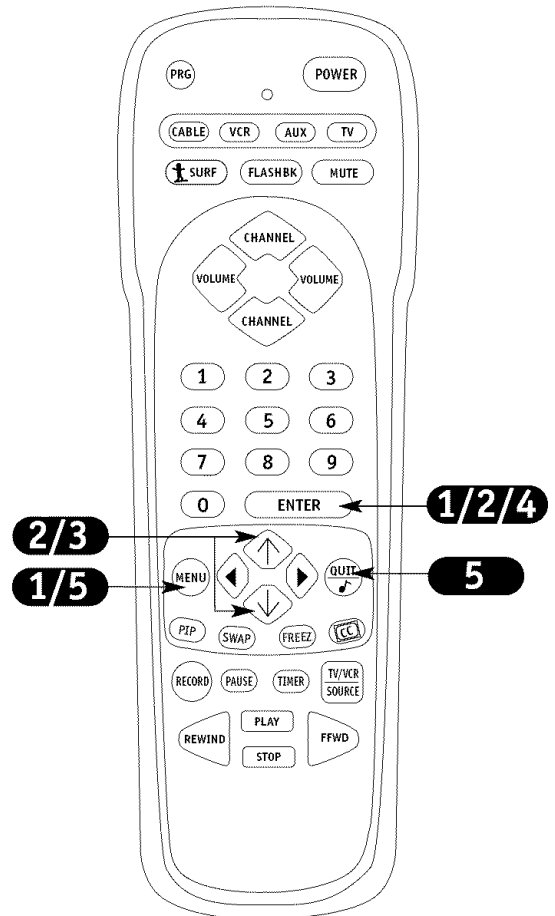

Mini glossary

- Air Antenna** The device receiving the program signal sent over-the-air.
- Cable TV** Your EZ Program selection, if you subscribe to a cable service.

On-Screen Menu Operation

Use the remote to access the on-screen menus

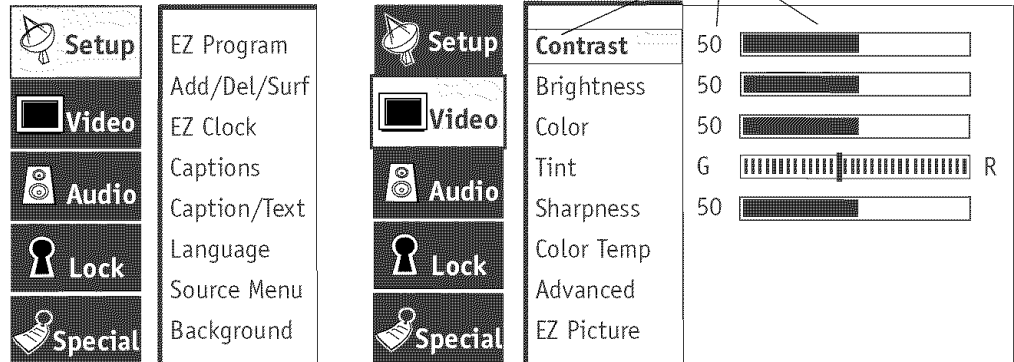

Main TV Features Menu

Video Menu

- 1** Press MENU on the remote control. Use the Up or Down directional arrow to “select” or highlight (*change the text color to gold*) the name of one of the five main menus on your screen like the VIDEO menu, then press ENTER.
- 2** Use the Up or Down directional arrow to highlight an option like CONTRAST, then press ENTER. You can select other menu options like COLOR TEMP by pressing the UP or DOWN directional arrow repeatedly.
- 3** Once the option is selected, in this case CONTRAST, use the RIGHT or LEFT directional arrow to adjust the setting; the larger the number the more contrast, the lower the number, the less contrast in the picture. Note: Some menu options use a checkmark to indicate setting, see page 19.
- 4** You can adjust the other menu options using the above procedure or if you are done changing the menu option settings:
 - a. Press MENU repeatedly to go back to the main menu.
 - b. Press QUIT to remove the menus from the TV screen.



Additional instructions are usually included on the bottom of the menu indicating which remote keys to use to move to the right, move to the left, or return to the original menu, etc.



Use the number keypad to enter numerical values when required.

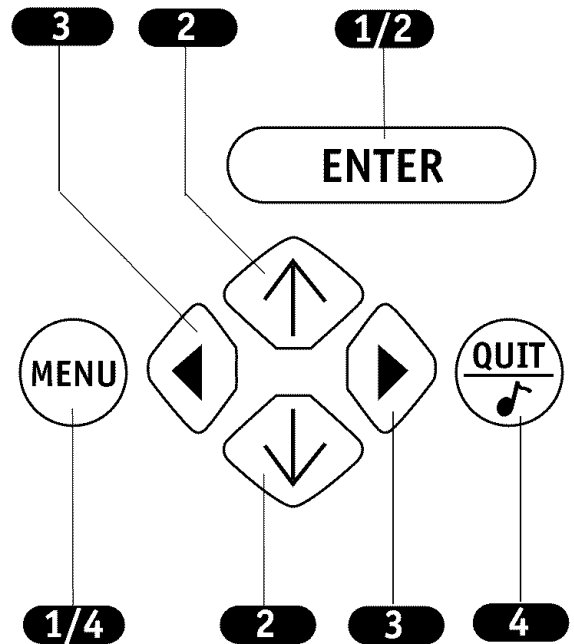















Mini glossary

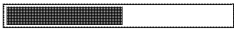





MENU	On-screen displays used to set up and operate TV features.
ENTER	Action key used to make changes on the menus.
UP/DOWN	Menu UP or DOWN directional arrows used to “select” or highlight and choose menu options.
LEFT/RIGHT	Menu LEFT or RIGHT directional arrows used to “adjust” some menu settings.
QUIT	Exits menus and removes on-screen displays.

Descriptions of the menus and displays

Using MENU, the Up/Down arrows, and the ENTER key and the other keys indicated on the remote, the user can access the menus and displays described below.

 Setup	EZ Program ✓ Cable TV
 Video	Add/Del/Surf Air Antenna
 Audio	EZ Clock
 Lock	Captions
 Special	Caption/Text
	Language
	Source Menu
	Background

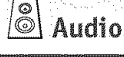
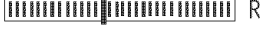
 Setup	Contrast 50	
 Video	Brightness 50	
 Audio	Color 50	
 Lock	Tint G	 R
 Special	Sharpness 50	
	Color Temp	
	Advanced	
	EZ Picture	

 Setup	Bass 11	
 Video	Treble 40	
 Audio	Balance L 2	 R
 Lock	Audio Mode	
 Special	EZ Bass	
	Front Surr	
	EZ Soundrite	
	Speakers	
	EZ Sound	

ON-SCREEN MENUS

SETUP 18

Sets the TV up and adjusts the basic features.

EZ Program 18

Automatically finds and stores active channels you tune to by using Channel Up/Down.

Add/Del/Surf 23

Choose which channels will appear when using Channel Up/Down. Adds favorite channels to Surf channel list.

EZ Clock 24

Sets the TV's clock.

Captions 25

Turns closed captioning On, Off, or set it to come on when the television sound is muted.

Caption/Text 25

Chooses a captioning or text option.

Language 26

Chooses the language you want the on-screen menus to appear in.

Source Menu 27

Selects which picture and sound will appear on your TV.

Background 28

Adds or removes menu background for better readability.

VIDEO 29 - 30

Adjusts the picture appearance to your preference.

Your options are:

Contrast, Brightness, Color, Tint, Sharpness, Color Temperature, Advanced (Aspect Ratio etc.), EZ Picture.

AUDIO 31

Customizes the sound to suit your room and taste.

Your options are:

Bass, Treble, Balance, Audio Mode, EZ Bass, Front Surround, EZ Soundrite, Speakers, EZ Sound.

On-Screen Menus/Displays Overview

LOCK 32 - 33 - 34
 Allows parents to block programming based on the program's content rating or the A/V source for up to 99 hours, with the use of a password.

SPECIAL 35 - 42
 Goes beyond basics and customizes your Entertainment Machine's features. Your options are:

EZ Timer 35 - 36

- Sleep Timer, Sets a time that the TV will automatically turn itself off, one time.
- Alarm, Sets the time the TV will turn on and off automatically each day.

Channel Labels 37
 Titles the channels with their network names (ABC, CBS, HBO, etc.).

XDS Display 38
 On/Off. If available, shows program information when a new channel is tuned to, or ENTER is pressed.

PIP Menu 39
 Adjusts the PIP inset image appearance.

Source Sense 40
 ON/Off. Controls how the Sources appear on the menu.

EZ Demo 42
 On/Off. Demonstrates the on-screen menus that control the TV's setup and operational features.

OTHER ON-SCREEN DISPLAYS (See pages indicated.)

- Surf's Up 22
- No Surfing 22
- Mute 22
- Volume Display 22
- Channel/Time 21
- Sleep Timer 22
- Captions/Text 21

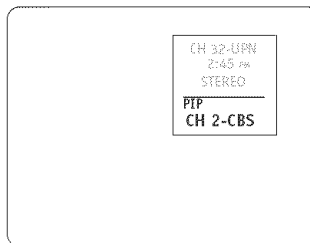
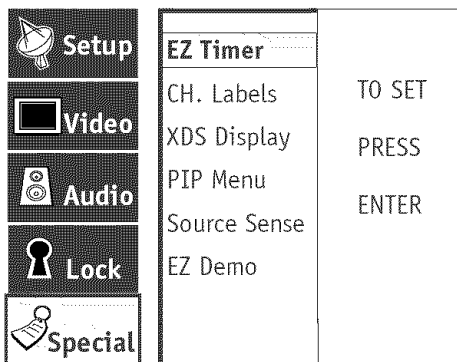
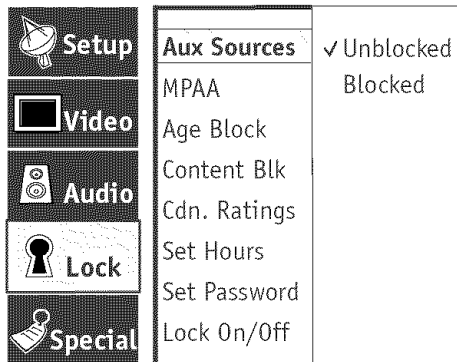

Channel/Time display shown with PIP on.

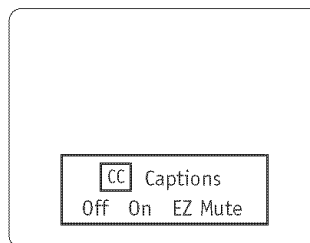

Closed Captions menu display.

Other Functions & On-Screen Displays

On-screen displays reveal the current status of your Entertainment Machine

A "Surf" Channels Mode Active Display

Press SURF to turn on Surf channels tuning mode; only channels specified as Surf channels will appear when using Channel Up/Down.

Surf's Up! 

No Surfing

Press SURF to display "No Surfing!" and return to normal channel tuning mode, using Channel Up/Down.

No Surfing 

B Mute Display

Press MUTE to quiet the sound.
Press MUTE again to remove the sound.
Press MUTE again to restore the sound.



C Volume Display

Press the VOLUME +/- key on the remote control to see the sound level status display.

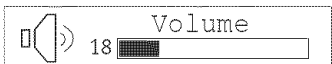

D Channel/Time Display

Press ENTER on the remote control to view the Channel/Time/incoming audio signal display.

E Remove On-Screen Displays and Menus Instantly

Press QUIT to remove displays and menus and return to TV viewing, or wait a few moments and the displays and menus will automatically disappear from the screen.

F Sleep Timer Display

Sleep Timer Status Display. Appears one minute before the TV automatically turns itself off.

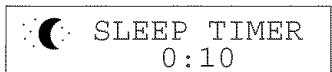

"Surf" Channels are typically your favorite channels that you tune to and watch frequently.

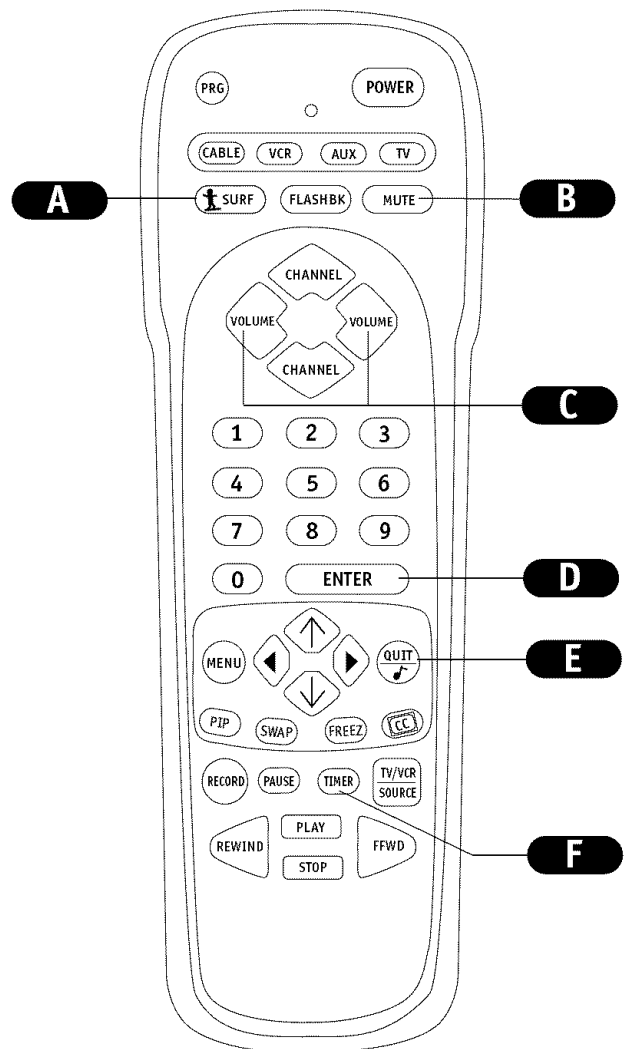

Channel Add/Delete/Surf Setup

Customize your channel selection list: Add Channels not found by EZ Program, Delete channels you don't watch, Create a favorite channels list to "Surf" - - with Surf on, only those channels specified as Surf channels will appear when using Channel Up/Down

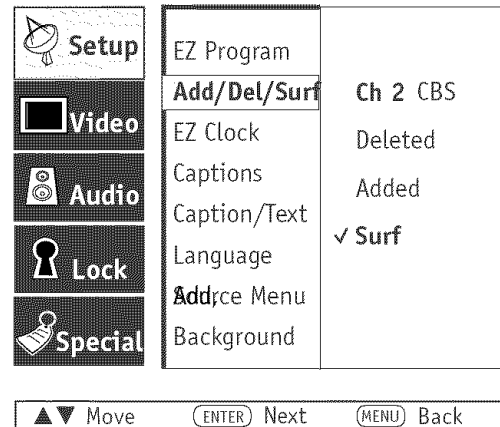

- 1** Use the NUMBER keypad to go to the Channel you want to Delete, or include in the Surf channel list.
- 2** Press MENU, use the Up/Down arrow to select the then press ENTER.
- 3** Use the Up/Down arrow to highlight the Add/Del/Surf option, then press ENTER.
- 4** Use the Up/Down arrow to pick ADDED, DELETED, or SURF; move the checkmark next to the option, then press ENTER.
- 5** Use MENU to go back to the SETUP menu. Press QUIT to remove menu when finished or go to another channel you want to add or delete by using the NUMBER keypad to select it and repeat from Step 3.



If you've deleted a channel, it isn't gone for good. Just select it using the NUMBER keypad on the remote, or add it later.



"Surf" channels are also automatically "Added."

Mini glossary

- ADDED** Includes new channels to the channel list that you'll scroll through when using Channel Up/Down.
- DELETED** Removes channels that you don't watch from the channel list you'll scroll through using Channel Up/Down.
- SURF** Adds your favorite channels to the Surf channel list. Press SURF, channels you specify as Surf channels will be the only ones to appear when you use Channel Up/Down. Press SURF to turn Surf off, (No Surfing!) and return TV to normal channel selection mode.

In the Setup menu with the EZ
ENTER to go to the EZ Clock Menu.

Use the Select UP or DOWN arrows, the Adjust LEFT or RIGHT
arrows, and the NUMBER keypad to set the clock menu options.
As indicated on the menu, use FLASHBK to set AM or PM.

EZ Clock Menu Options

Press QUIT to return to TV viewing.

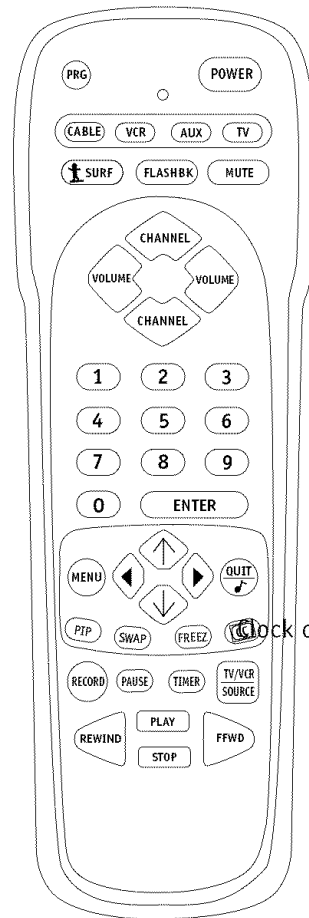

Turn on Closed Captioning or Captions Setup menu, select On, Mute, EZ/Mute. ~~ENTER~~ Press a Closed Captions or Text option

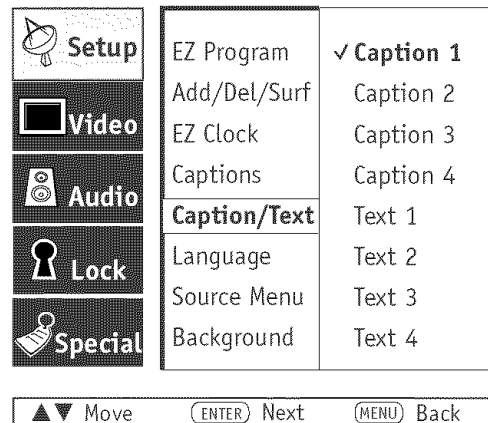

Caption/Text allows your Entertainment Machine to receive various closed caption and text options provided by broadcasters. Availability and functionality of Caption/Text is determined only by the broadcaster and may not be available on a given program. Standard captions are usually on Caption1, standard text is usually on Text 1.

- 1** Press MENU, use the Up/Down arrow to then press
- 2** Use the Up/Down arrow to choose Captions, then press ENTER.
- 3** Use the Up/Down arrow to
 Note: If you selected either On or EZ Mute, then use the Up/Down arrows to choose an option from the Caption/Text menu: Caption 1, Caption 2, Caption 3, Caption 4, Text 1, Text 2, Text 3, or Text 4; so that the option will appear when the TV is muted or a program is tuned to that has Closed Captions or Text.
- 4** Press QUIT to remove menu and return to TV viewing.



Captions come in handy when the television is on mute. Standard closed captioning is available using the Caption 1 option.



Not all programming has closed captioning or text available; even though Captions 1, 2, 3, 4, and Text 1, 2, 3, 4 are available to broadcasters.

Mini glossary

CAPTIONS The term for the words that scroll across the bottom of the TV screen; usually the audio portion of the program provided for the hearing impaired.

TEXT The term for the words that appear in a large black frame and almost cover the entire screen; usually messages provided by the broadcaster.

Language

Choose the language you want the on-screen menus to appear in

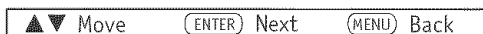
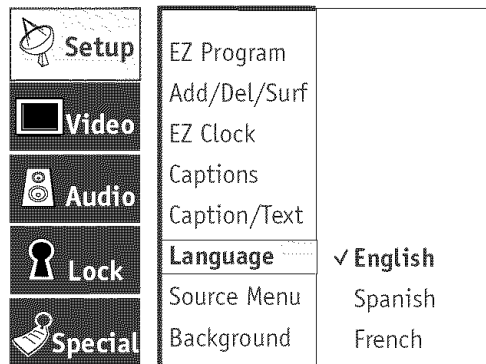
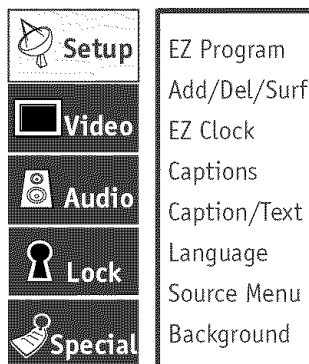

- 1** Press MENU, use the Up/Down arrow to select the SETUP menu, then press ENTER.
- 2** Use the Up/Down arrow to select the Language option on your screen, then press
- 3** Use the Up/Down arrow to choose any of the following options: English, Spanish or French, then press ENTER.
- 4** Press QUIT to remove menu and to return to TV viewing.

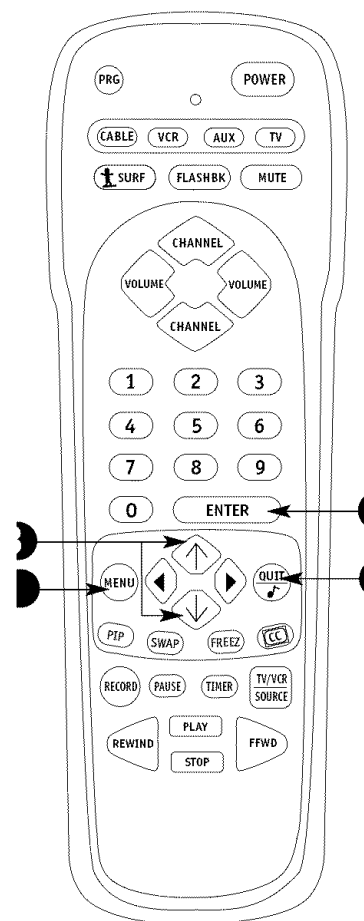

Selecting Sources: Main/PIP Picture

Choose the picture and sound you want to see and hear for the main screen and PIP inset

Using SOURCE to Choose Viewing Sources

Press SOURCE repeatedly to scroll through the available sources: Antenna, Video 1, Video 2, F Video, DVD, HD, HD-RGB. (Note: See page 40 for source sensing options.)

Selecting Sources with the Menus

Press MENU to show the menus

Use the Up/Down arrow to select the SETUP MENU option, then press ENTER.

Use the Up/Down arrow to select the **Source Menu**, then press ENTER. (Use MENU to go backward as needed.)

Use the Up/Down arrow to move the checkmark and select Antenna, or one of the other available sources, then press ENTER.

After you have selected viewing sources for the Main picture and PIP inset, press QUIT to remove menus and return to TV viewing.

Background Menu

Set the background option to On and add a blue background to increase the readability of the menus

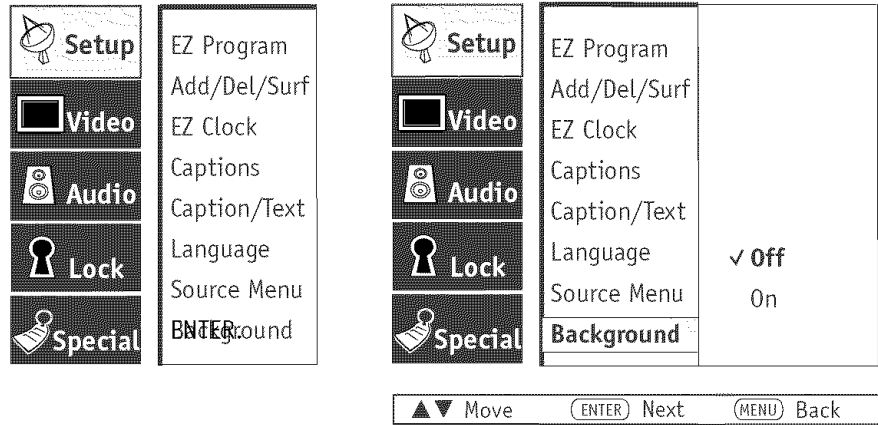

1 Press MENU, use the Up/Down arrow to select the SETUP menu, then press ENTER.

2 Use the Up/Down arrow to select the Background option on your screen, then press

Use the Up/Down arrow to select On or Off.

Press QUIT to remove menu and to return to TV viewing.

Video Menu

Use the Video menu to customize the picture appearance

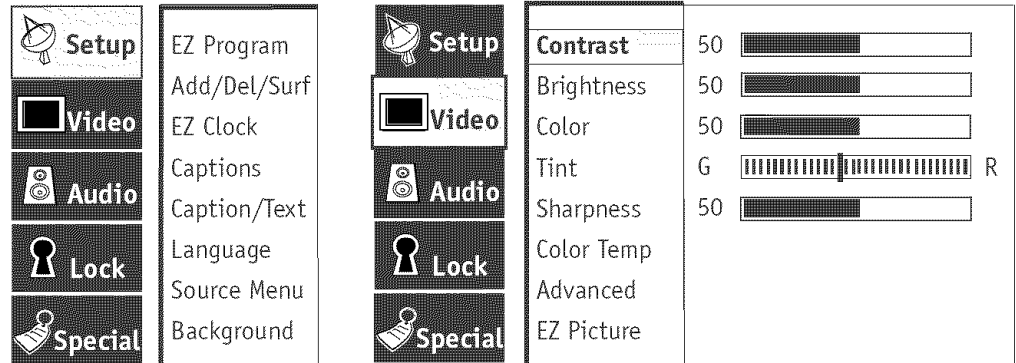

▲▼ Move (ENTER) Next (MENU) Back

- 1** Press MENU, use the Up/Down arrow to select the Video menu, then press ENTER.
- 2** Using the Up/Down arrow on the remote control, choose Contrast (or another option on your screen), then press ENTER.
- 3** Using the Left/Right arrow, change the Contrast level to your preference.
- 4** Press QUIT, to return to TV viewing, or press MENU and repeat from step two to set the other menu options. Your options are:
 - **Contrast:** Adjusts the level of difference between white and black in the TV picture. The more contrast, the brighter the picture appears.
 - **Brightness:** Increases or decreases amount of white in the TV picture.
 - **Color:** Adjusts levels of all colors in the TV picture.
 - **Tint:** Adjusts the relative amounts of red and green colors in your picture.
 - **Sharpness:** Raises or lowers the definition of the picture. The lower the level, the softer the image will appear.
 - **Color Temp:** Adjusts levels of all colors in the TV picture; Cool or Warm.
 - **Advanced Video Menu Options:** See next page.
 - **EZ Picture:** Choose either Custom, Normal, Movie, Digital, Video Game, Sports, Night Time, or Weak Signal.
 - Custom: Allows you to adjust the picture the way you want.
 - Normal: Resets the options to their original settings.
 - Other options adjust the picture to the source's image.

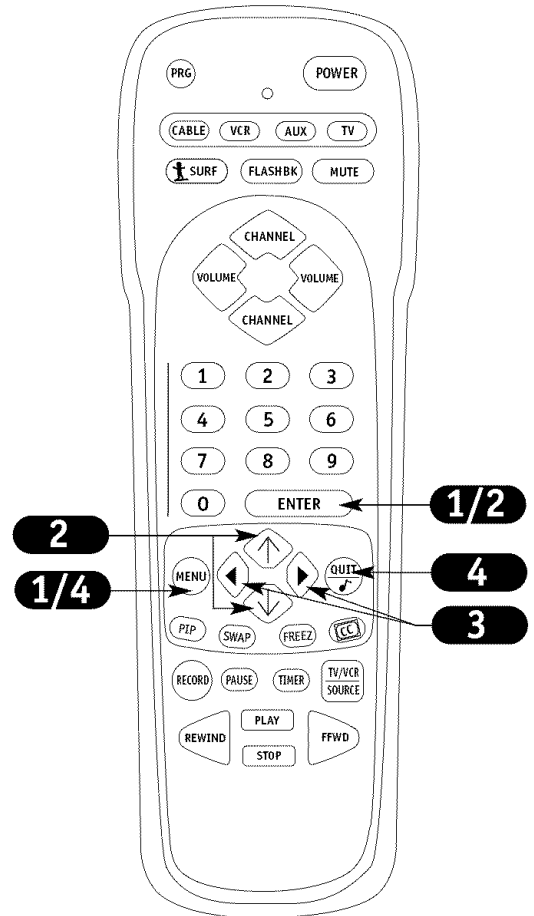

Choose the **NORMAL** option in EZ Picture to quickly reset the Video Menu options to their original pre-set values, or use your own settings with **CUSTOM**.



Use the **PIP** menu to set your preferences for the PIP inset picture.

Video Advanced Options Sub-Menu

Use the Video menu to customize the picture appearance to your preference

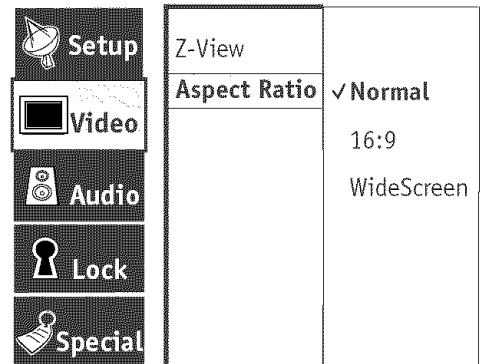
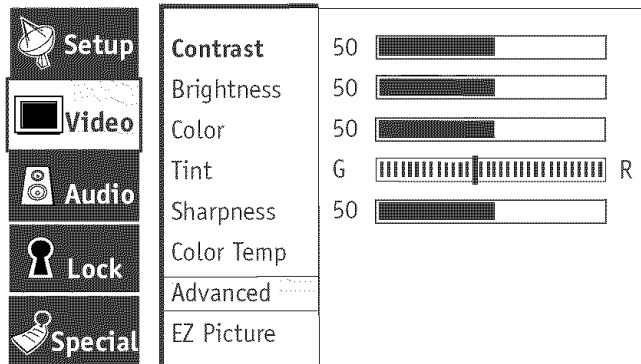

▲▼ Move (ENTER) Next (MENU) Back

- 1 With the Video menu option selected, press ENTER.
- 2 Use the Up/Down arrow to select Advanced, then press ENTER. Your options are:
 - **Z-View:** Can be turned on and off to change the appearance of the picture to your preference.
 - **Aspect Ratio:** Selects the proper picture proportion to match the source's image; Normal, 16:9, WideScreen.
- 3 Using the Up/Down arrow, choose Aspect Ratio on the menu (or choose another option), then press ENTER.
- 4 Using the Up/Down arrow, change the Aspect Ratio to the correct video proportion: Normal, 16:9, or WideScreen.
- 5 Press QUIT, to return to TV viewing, or press MENU and repeat from step two to set the other menu options.

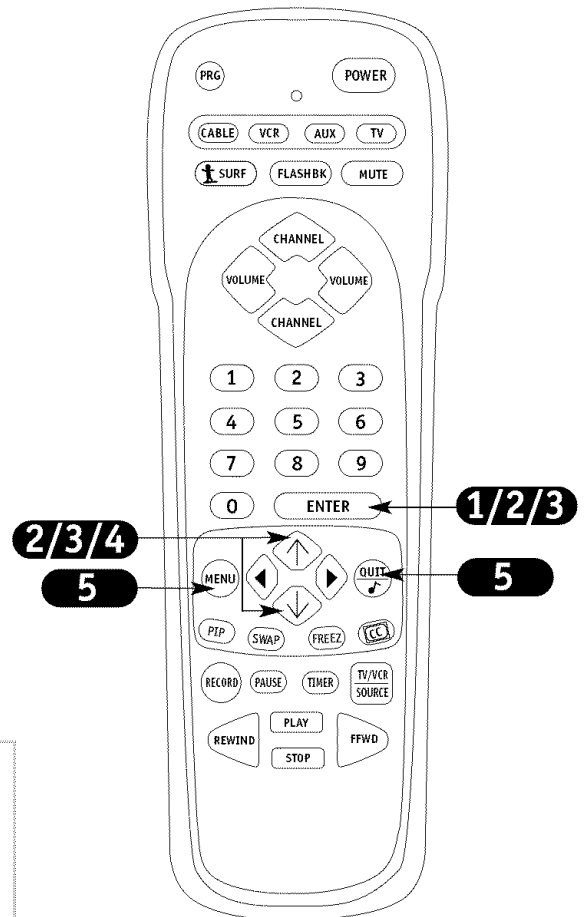

Mini glossary

NORMAL	Standard 4 x 3 almost square-like picture proportion used for most TV formats.
16X9	Wider than normal picture format used for HD sources that produce a more movie theater-like image.
WIDESCREEN	Picture zoom-like effect to fill screen.

Audio Menu

Adjust the sound to your preference and set up the audio features

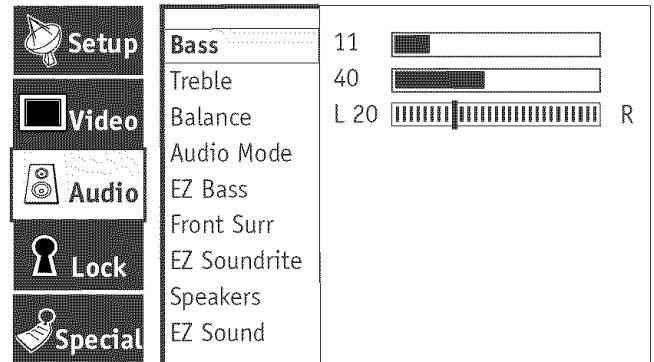
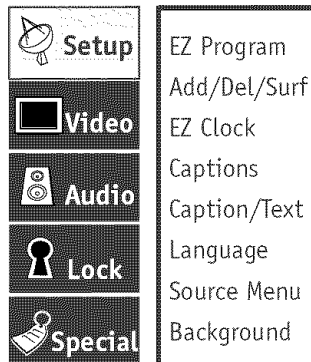

▲▼ Move (ENTER) Next (MENU) Back

- 1 Press MENU, use the Up/Down arrow to select the Audio menu, then press ENTER.
- 2 Using the Up/Down arrow on the remote control, highlight the audio option you want to change, then press ENTER. Choose from:
 - **Bass:** Increases/decreases lower-end sounds.
 - **Treble:** Increases/decreases higher-end sounds.
 - **Balance:** Allows you to put the sound more to the left or right channel.
 - **Audio Mode:** Choose from Stereo sound, Mono sound, or 2nd Audio/SAP.
 - **EZ Bass:** Turns the bass booster function on or off.
 - **Front Surround:** Turns front surround sound on or off.
 - **EZ SoundRite:** Turns the uniform volume level on or off.
 - **Speakers:** Turns the TV speakers on or off.
 - **EZ Sound:** Use one of the five factory audio presets: Normal, Stadium, News, Music, Theater, or your own "Custom" settings.
- 3 Use the Left/Right arrow to adjust or change the selected option.
- 4 Use the Up/Down arrow to select another audio option and adjust it or press QUIT to return to TV viewing.



Not all programming is broadcast in stereo sound or has 2nd Audio SAP.

Mini glossary

STEREO SOUND	Stereo (stereophonic) sound refers to audio that's divided into right and left sides.
MONO SOUND	Mono (monaural) sound is one channel of sound. For more than one speaker, all the speakers play the same audio.
2nd Audio/SAP	Second audio program provided by some broadcasters; usually a different language.

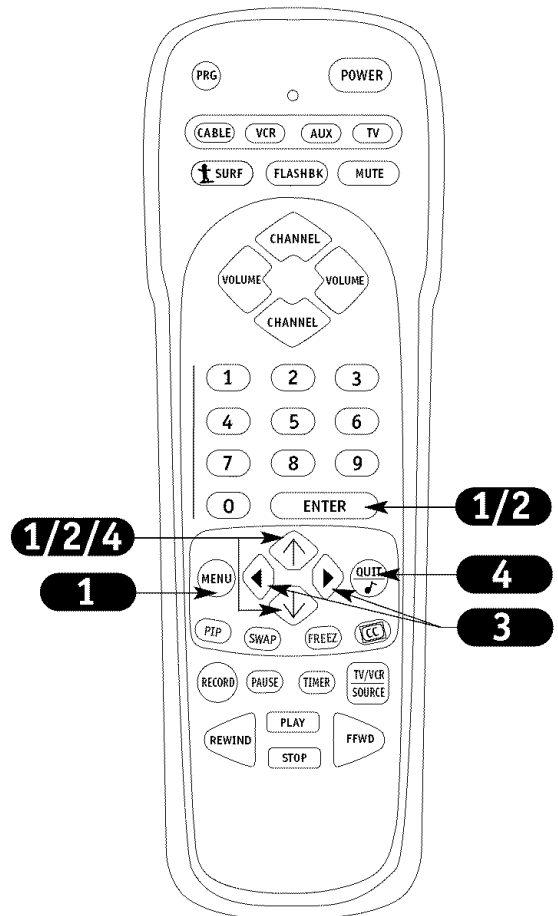

If used, this optional feature can “block” undesirable programming from appearing on the TV.

Note: Lock, also known and referred to in the text as Parental Control, is not available in Computer Mode. To block Computer inputs, use the block AUX SOURCES option in the Lock menu in TV Mode; computer inputs will not be available.

Lock/Parental Control offers the user a wide variety of options and settings that restrict or “block” the programming that can appear on the TV. Parental control allows the user the capability of defining which program rating they consider acceptable, to the younger or more sensitive viewer. It can be preset and turned either on or off by the user who specifies the secret 4-number code, the password. The number of hours blocked are specified. General audience and children viewer blocks should both be programmed into the TV’s memory. Viewer ratings are specified for both TV and the motion picture industry; both rating systems should be used, for complete coverage. The ratings are based mainly on children’s ages.

Overview

To insure complete coverage for all TV programs (movies, Sex Scenes, Violence, etc.) choose a rating for MPAA, from the selections below AND choose ratings from the TV Parental Guidelines Rating System on the next page, using the Age Block option for General Audiences, and for Children. In addition to those, you may wish to add additional restrictions from the Content Block menu. See the Parental Control menu, and submenus example on the next two pages.

Things to Consider before Setting Up Lock (Parental Control)

- Determine which rating you consider acceptable to the viewer. (For example, if you choose TV-PG, all more restrictive ratings will be automatically blocked; the viewer will not be able to see: TV-PG, TV-14, or TV-MA rated programming.)
- Do you want to block the auxiliary video source entirely? (Blocks the signal sent by the equipment, such as a VCR, connected to the TV Audio/Video input jacks; in the Aux. Block option.) Or leave unblocked, then choose allowable ratings.
- Block program “Content” based on individual Scenes, or Fantasy Violence Scenes; in the Content Blk option.
- How many hours do you want Parental Control to be active? You can set the Hours option for up to 99 hours.
- Select a secret password; in the Set Password option. Use the number keys on the remote. Don’t forget the password, it is the only way you can access the Parental Control menu and change rating selections, or turn Parental Control off.
- Do you want Parental Control to be active all the time? If not, you can turn it on or off; with the Lock On/Off option.

You can set different Parental Control viewing restrictions for general audiences and for children - - both can be active at the same time.

Simply specifying one content block such as Sex Scenes, will not automatically block another content in the programs from appearing.

Even if you choose to leave the Aux inputs unblocked, the ratings you specify will automatically restrict the programming that appears from the video sources.



You cannot disable Parental Control by disconnecting the TV from power. Block hours will automatically reset to the original block time setting specified if power is disconnected.

Lock Menu

After you have read the preceding page, follow instructions below to set up and activate Lock

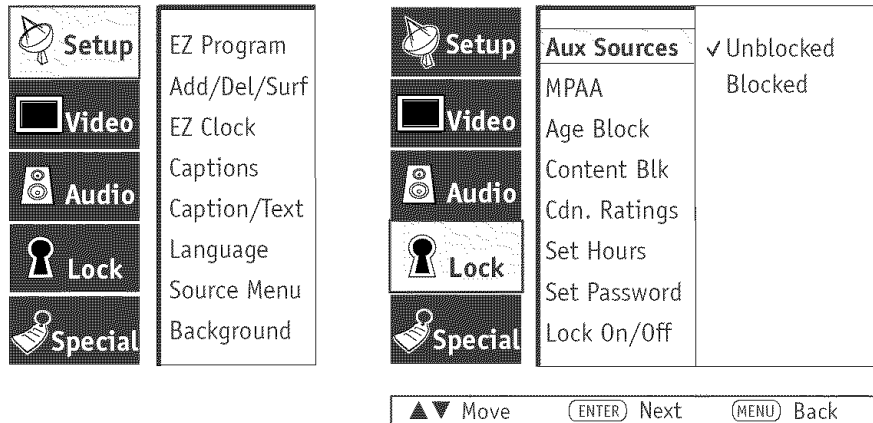

- 1** As shown above, with the Lock menu on-screen, use the Up/Down arrow to highlight an option like Content Blk, then press ENTER.
- 2** Use the Up/Down/Left/Right arrows to select and adjust or set the rating for an option. For Sex Scenes for example, use the "From TV-PG" setting. (See the Mini Glossary, Ratings Charts on this and the previous page for rating definitions.)
- 3** After you have selected and adjusted the Lock menu options to your preference:
 - Set the hours you want Lock (Parental Control) active.
 - Set a 4-number password.
 - Set the Lock On/Off option to either on or off.

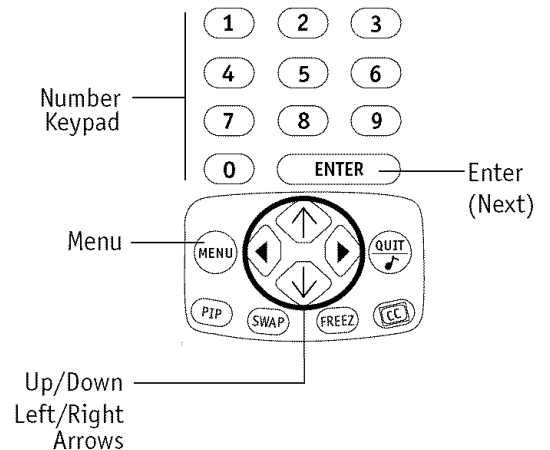

Note: No Rating means the broadcast does not include rating information. You can choose to block broadcasts without rating data.

Mini glossary

MOTION PICTURE ASSOCIATION OF AMERICA (MPAA) RATING SYSTEM

G	General Audiences	Content not offensive to most viewers.
PG	Parental Guidance Suggested	Content is such that parents may not want their children to view the program.
PG-13	Parental Guidance Suggested	Program is inappropriate for preteens, with a greater degree of offensive material than a PG rated program.
R	Restricted viewing	Not for children under age 17. Strong elements of sex and/or violence.
NC-17	Restricted Viewing	Not for children under age 17 under any circumstances. Strong sexual content.
X	Hard Core Films	Same as NC-17 rating.

Note: Zenith Electronics Corporation is not liable for any program content that appears when using this rating system; as always, user discretion is advised.

Lock Menu Structure

Lock menus with various restriction options are shown below

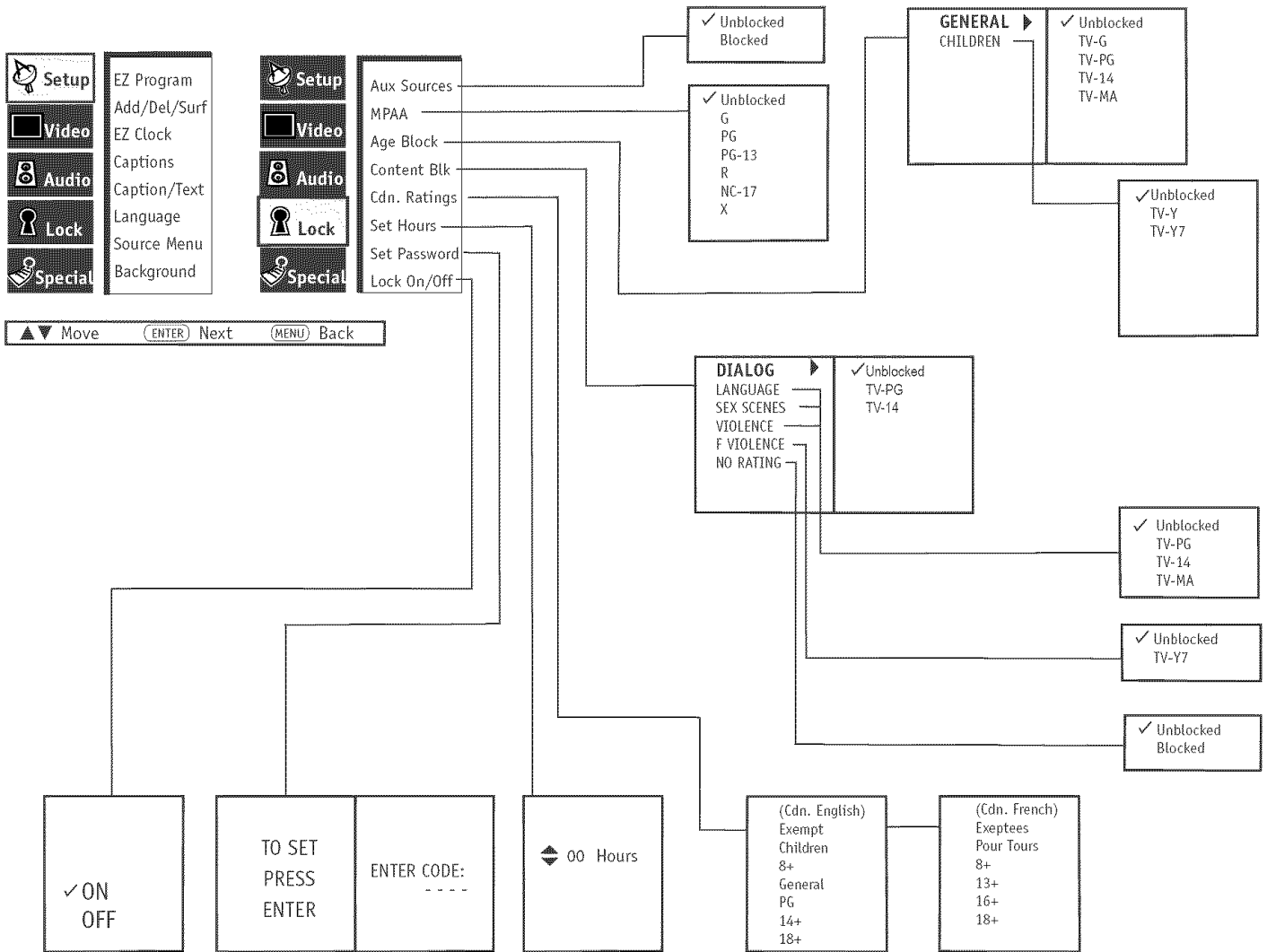

Mini glossary

TV PARENTAL GUIDELINE RATING SYSTEM

TV-G	General Audience	Considered suitable for all audiences; children may watch unattended.
TV-PG	Parental Guidance Suggested	Unsuitable for younger children, may contain: Suggestive Dialog, Bad Language, Sex, and Violence Scenes.
TV-14	Parents Strongly Cautioned	Unsuitable for children under 14, may contain: Strong Dialog, Bad Language, Sex, and Violence Scenes.
TV-MA	Mature Audience Only	Adults only, may contain: Strong Dialog, Bad Language, Sex, and Violence Scenes.

CHILDREN'S CLASSIFICATIONS

TV-Y	Children	Considered suitable for all children under 7 years old.
TV-Y7	Children 7 and over	Considered suitable for children over 7, may contain Fantasy Violence Scenes.

EZ Timer: Sleep Timer Menu

Set the Sleep Timer to automatically turn the TV off, after the preset time has expired

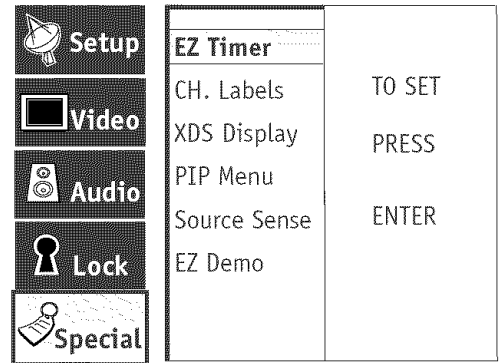
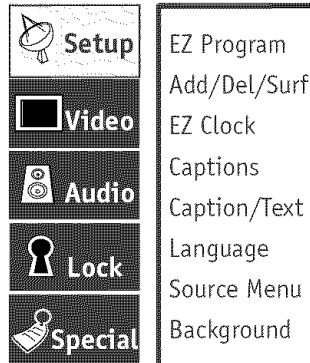

Sleep Timer

- A** Use TIMER to choose a preset time from 10 minutes to 4 hours for the TV to automatically turn itself off.

Using the EZ Timer Menu

Selecting Sleep Timer Menu



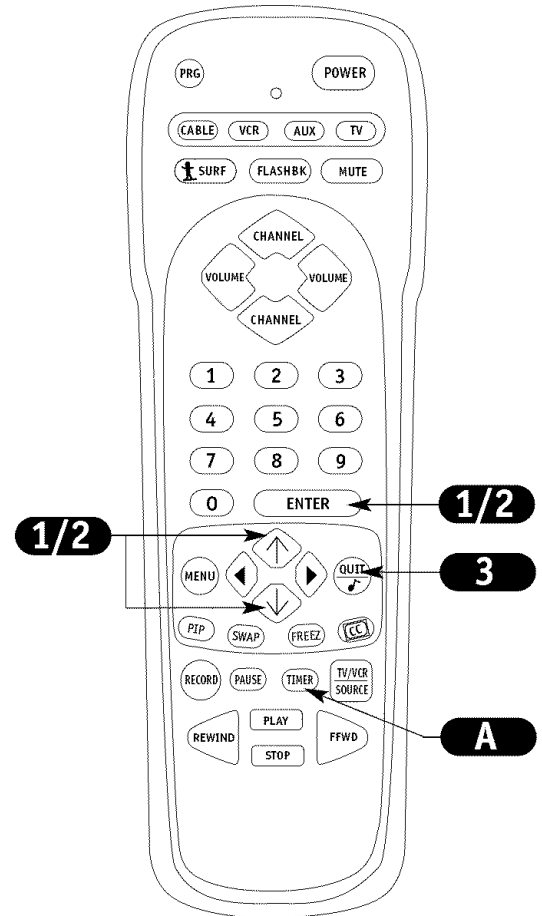

- 1** With the EZ Timer menu selected, press ENTER. Use the Up/Down arrows to choose Sleep Timer, then press ENTER.
- 2** Use the Up/Down arrows to select a preset TV turn-off time from the options listed, press ENTER.
- 3** Press QUIT to return to TV viewing.







One minute before TV turnoff, the Sleep Timer on-screen display will appear letting you know that the TV will turn itself off in the time specified.

EZ Timer: On/Off Timer Menus

Set the On/Off timers to turn the TV on each day at the specified time and off, or have the timer settings retained and disable the On/Off function temporarily

 Setup	EZ Program
 Video	Add/Del/Surf
 Audio	EZ Clock
 Lock	Captions
 Special	Caption/Text
	Language
	Source Menu
	Background

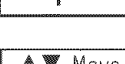
 Setup	EZ Timer	
 Video	CH. Labels	TO SET
 Audio	XDS Display	PRESS
 Lock	PIP Menu	ENTER
 Special	Source Sense	
	EZ Demo	

▲▼ Move ENTER Next MENU Back

1 **Setting the TV Turn On Time**
With the EZ Timer menu selected, use the Up/Down arrows to choose On Time, then press ENTER.

2 Use the number keypad or the Left/Right arrows to pick a time for the TV to automatically turn itself on each day. Use FLSHBK to set AM or PM.

1 **Setting the TV Turn Off Time**
With the EZ Timer menu selected, use the Up/Down arrows to choose Off Time, then press ENTER.

2 Use the number keypad or the Left/Right arrows to pick a time for the TV to automatically turn itself off each day. Use FLSHBK to set AM or PM.

1 **Using the TV On/Off Timer Option**
With the EZ Timer menu selected, use the Up/Down arrows to choose On/Off Timer, then press ENTER.

2 Select On of Off
On: TV on/off timers function each day.
Off: TV on/off timers do not function although on/off time settings are retained in menu.

3 Press QUIT to return to TV viewing.

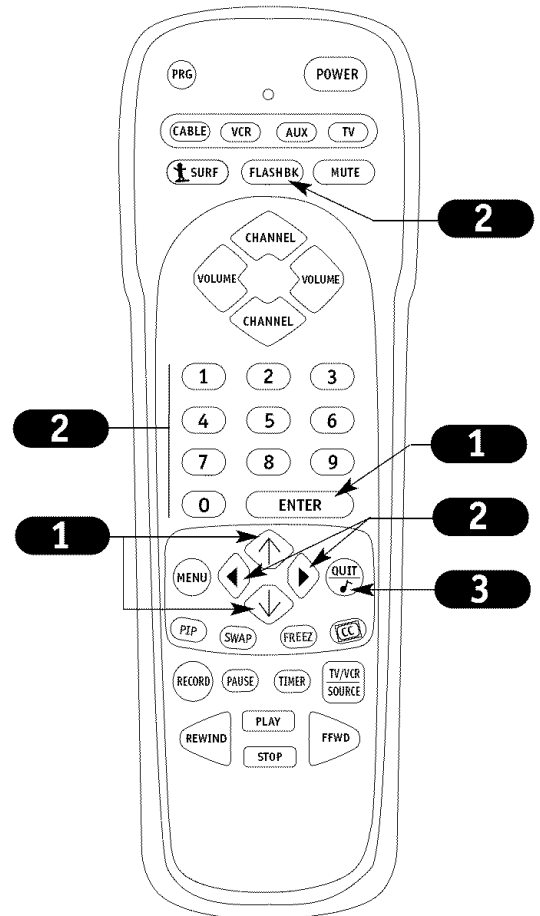

Using Preset Channel Labels

Customize your Channel/Time on-screen display by adding preset Channel Labels

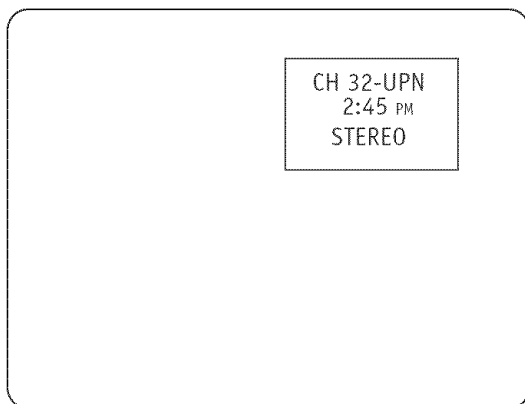

Channel/Time Display

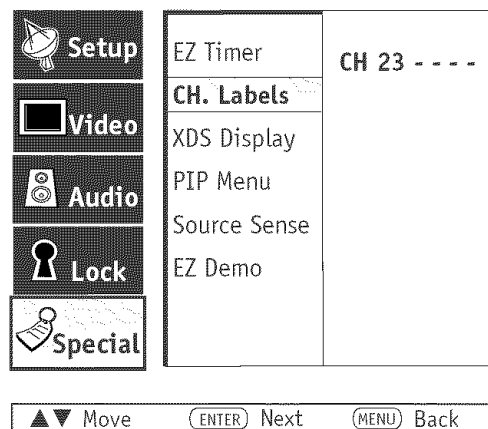

- 1** Using either the NUMBER keypad or the Channel Up/Down keys on the remote, select a channel.
- 2** Press MENU, use the Up/Down arrow to select Special, then press ENTER.
- 3** Select the Ch. Labels option using the Up/Down arrow, then press ENTER.
- 4** Pressing either the Up or Down arrow repeatedly, pick the label you want from the available selections; such as A & E.
- 5** To continue channel labeling, select another channel or if you are finished, press QUIT to remove menu.



Some channels already provide a channel label which is included with the broadcast signal.



Labeling the channels helps identify which familiar nationwide channels are available. For example, A & E - Arts and Entertainment, CNN - News, ESPN - Sports, HBO - Movies, and so on...

Mini glossary

- - - - The 4 dashes will allow a channel label to appear; if one is provided by the broadcaster.

NONE Prevents any channel label from appearing.

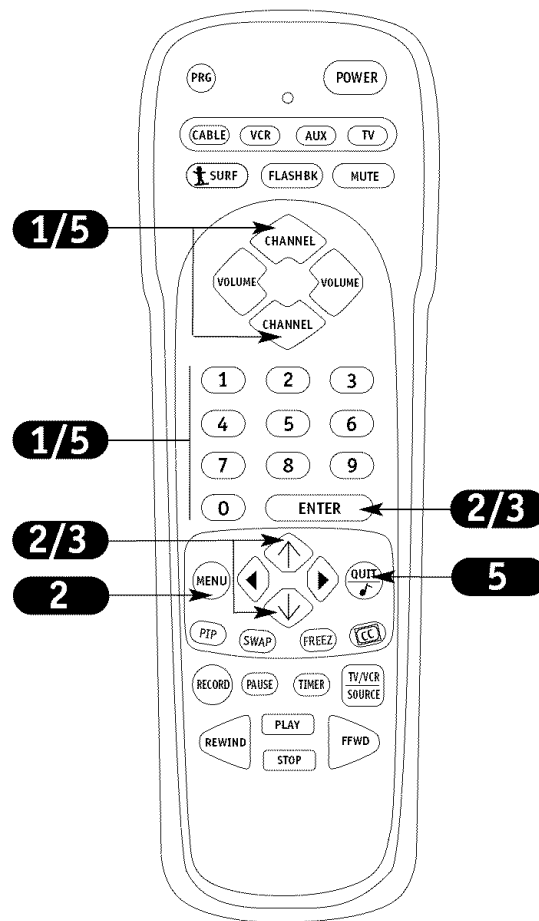

XDS On-Screen Display

Let the Extended Data Service display in-depth program information

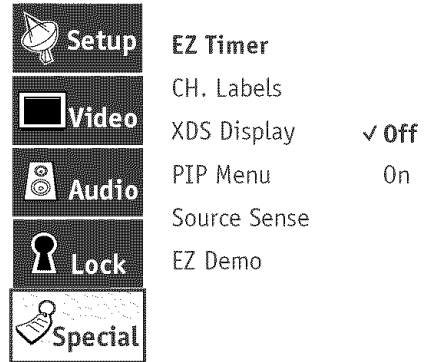
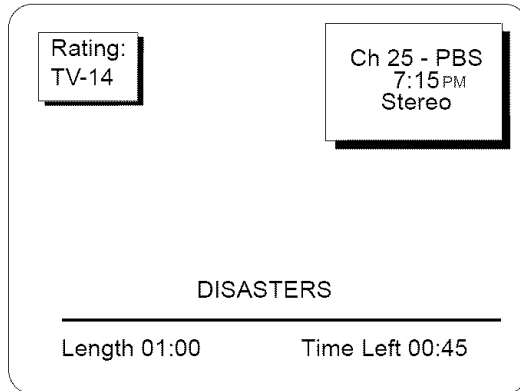

▲▼ Move (ENTER) Next (MENU) Back

- 1** Press MENU, use the Up/Down arrow to select the SPECIAL menu on your screen, then press ENTER.
- 2** Use the Up/Down arrow to select the XDS DISPLAY option, then press ENTER.
- 3** Use the Up/Down arrow to choose: On, or Off.
On: XDS Display will appear as channels are changed or ENTER is pr
Off: XDS Display will not appear.
- 4** Press QUIT to remove the menu and return to TV viewing.



At this printing, XDS data may only be provided by some broadcasting stations; and as a result, may only be available on some channels.



Even though XDS data may be present, it may not be available during commercial or network breaks.

Mini glossary

XDS Extended Data Service - - If provided by the broadcaster, may show some or all of the following information:

Channel/Time/Audio display. Network label if present. Title of program. Length of program in hours and minutes. Time remaining on the program in hours and minutes. Program content rating, and if PIP is active, the PIP channel number.

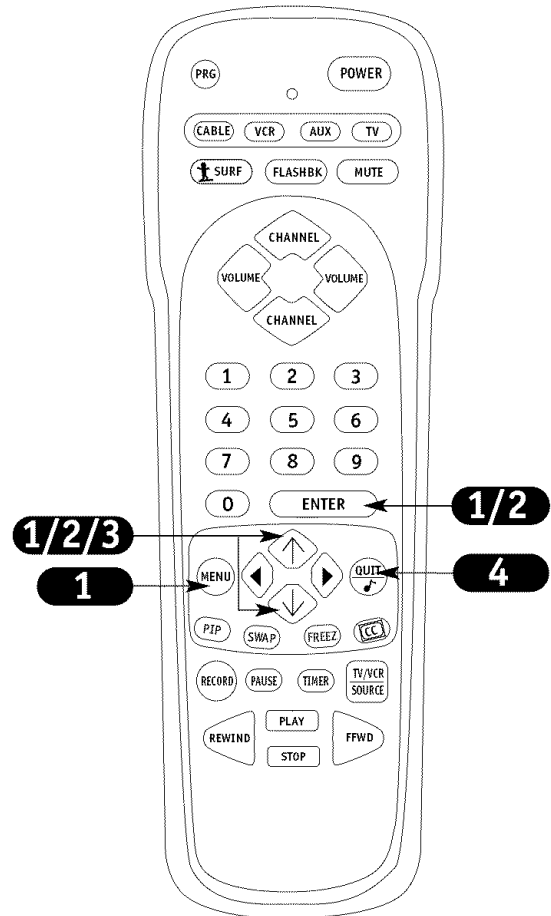

PIP Inset Picture Adjustments

Set the PIP inset picture appearance options to your personal viewing preferences

Setup	EZ Timer	
Video	CH. Labels	TO SET
Audio	XDS Display	PRESS
Lock	PIP Menu	ENTER
Special	Source Sens	
	EZ Demo	

Contrast	50	
Brightness	50	
Color	50	
Tint	G	
Size		

Move Next Back

- 1** Press MENU. Use the Up/Down arrow to select the SPECIAL menu, press ENTER.
- 2** Use the Up/Down arrow to select the PIP Menu option, then press ENTER. Your options are:
 - **Contrast:** Adjusts the level of difference between white and black in the TV picture. The more contrast, the brighter the picture appears.
 - **Brightness:** Increases or decreases amount of white in the PIP picture.
 - **Color:** Adjusts levels of all colors in the PIP picture.
 - **Tint:** Adjust the relative amounts of the color red and green in the PIP picture.
 - **Size:** Chooses the size that the PIP inset will appear on the screen: Small or Large.
- 3** Using the Up/Down arrow on the remote control, choose Contrast on your screen.
- 4** Using the Left/Right arrow, change the contrast level to your preference.
- 5** Press QUIT, to return to TV viewing, or press MENU and repeat from step two to set other PIP inset appearance menu options.



See the PIP section for Picture-in-Picture setup and operation.

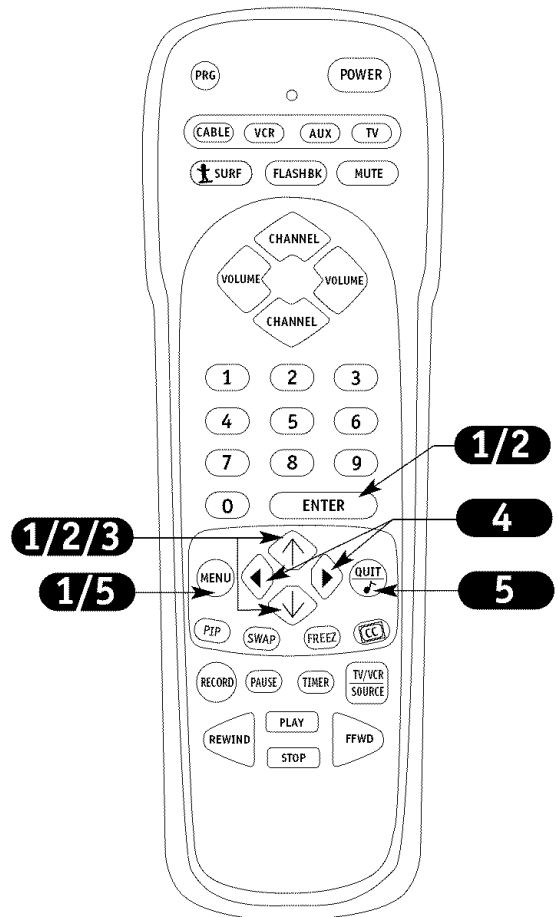

Press MENU, then press

Use the Up/Down arrow to select the SPECIAL menu, then press ENTER.

Use the Up/Down arrow to select SOURCE SENSE, then press ENTER.

Use Up/Down to select On or Off.

Press QUIT to remove menus and return to TV viewing.

Source Selection Options

Choose the connected source you want to see and hear on your Entertainment Machine

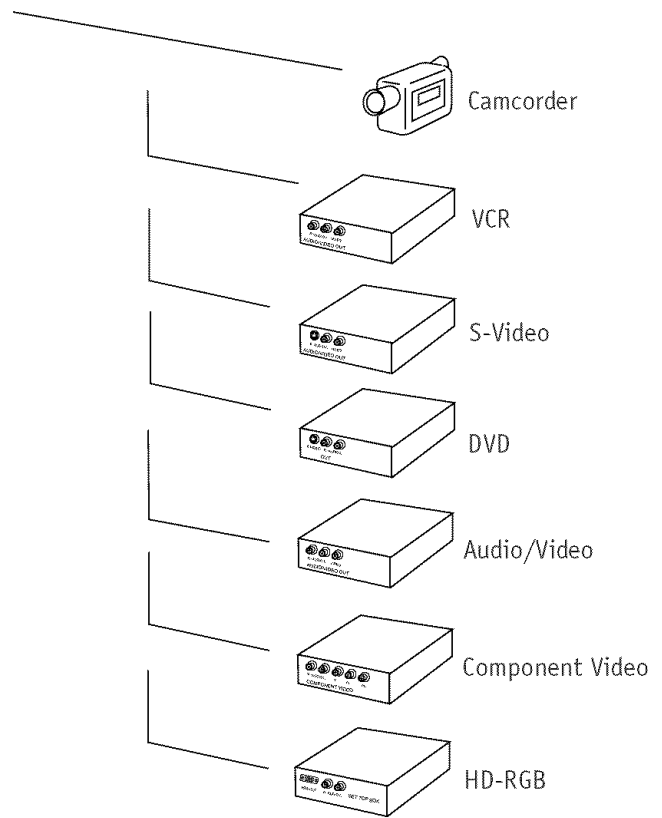
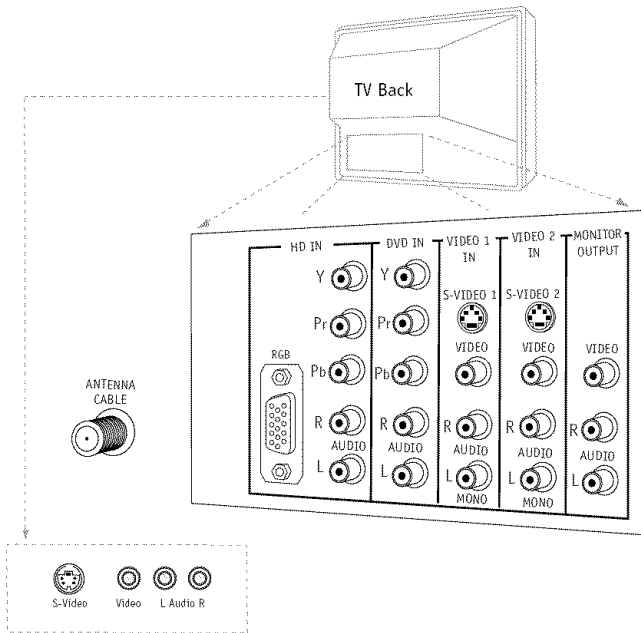

1 Press SOURCE repeatedly to choose from the available viewing sources or use the Source menu.

Antenna: Antenna/Cable on TV back near Jackpack, Over-the-Air Antenna or Cable service signal source.

Video 1 In: on TV back Jackpack, Set of Composite Audio/Video Input jacks.

Video 2 In: on TV back Jackpack, Set of Composite Audio/Video Input jacks.

F Video In: on TV front Jackpack, Set of Composite Audio/Video Input jacks.

F S-Video In: on TV front Jackpack, S-Video Input jack use with front Audio Input jacks.

DVD IN: on TV back Jackpack, Set of Component Audio/Video Input jacks.

HD IN: on TV back Jackpack, Set of Component Audio/Video Input jacks.





HD-RGB Input: on TV back Jackpack, 15 Pin RGB Input connector, use with HD-In R-L Audio.







The source equipment you intend to view should be turned on.

EZ Demo Menu

Your Entertainment Machine can show you the menus available

 Setup	EZ Program
 Video	Add/Del/Surf
 Audio	EZ Clock
 Lock	Captions
 Special	Caption/Text
	Language
	Source Menu
	Background

 Setup	EZ Timer	
 Video	CH. Labels	TO SET
 Audio	XDS Display	PRESS
 Lock	PIP Menu	ENTER
 Special	Source Sense	
	EZ Demo	

▲▼ Move (ENTER) Next (MENU) Back

- 1** Press MENU and use Up/Down arrow to select the SPECIAL menu on your screen, then press ENTER.
- 2** Use the Up/Down arrow to select the EZ DEMO option, then press ENTER.
- 3** Use the Up/Down arrow to choose either:
On; then press ENTER. EZ Demo will continue to run (*even if the TV is turned off and on again*) until it is turned off in the SPECIAL menu.
Off; EZ Demo will not be active.
- 4** Press QUIT to remove menu.



Even if the TV is turned off, the EZ Demo feature will continue to operate when the TV is turned on again.

The only way to turn EZ Demo off is to select Off in the SPECIAL menu.

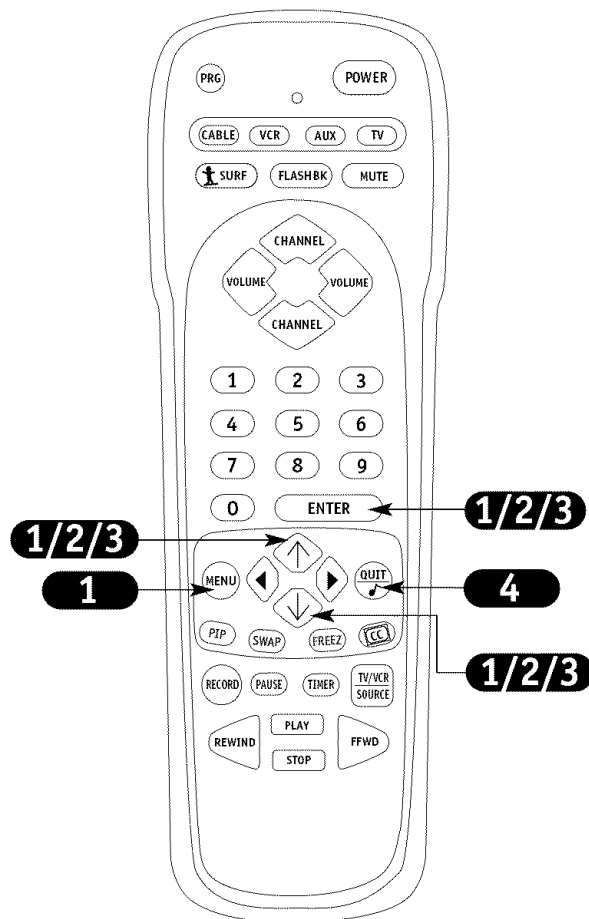

Mini glossary

EZ DEMO Feature provides an automatic demonstration of the on-screen menus on your Entertainment Machine.
View and learn what features are available to you as EZ Demo cycles through the on-screen menus.

Picture-In-Picture Overview

PIP = Picture-In-Picture

Think of PIP as a mini TV screen superimposed onto your main TV screen

Press PIP on the remote to place the PIP inset on the screen, press PIP again to remove it

YOUR PICTURE-IN-PICTURE FEATURE

The Picture-In-Picture (PIP) function allows you to put a smaller picture, called the "inset," on the bigger screen, or the "main" picture.

You will need to have another source, (audio/video device connected to the TV) like a VCR; to use as a source to display an additional picture.

Don't want to miss any of the big game, but hate commercials? When the broadcaster breaks for a commercial, just tune the VCR to the channel with the game being broadcast for the PIP inset, and Surf your favorite channels on the main picture screen.

WORKING WITH PIP

Just like your Entertainment Machine's main screen, PIP will need a source to take its image from.

PIP Sources

Antenna/Cable, Video 1, Video 2, F Video. S-Video sources can also be used for the PIP picture.

SOME TYPICAL PIP/MAIN SCREEN VIEWING SETUPS

1. You want to watch a videotape, but keep scanning for another movie or game. Set the PIP source to Video 1, or 2 and you can watch the VCR and TV, swapping between the two.
2. You want to watch your favorite live program on Antenna on the main screen and when a commercial break appears, swap to the PIP inset; which has a videotape in the VCR ready to play, or Surf your favorite channels using the Antenna source for the PIP inset.
3. To monitor an infant asleep, connect a camcorder to F Video for the PIP source and watch a TV channel from the Antenna/Cable source on the main picture screen.



If no equipment is connected to a source you select for the PIP inset, or if it is turned off, the PIP inset will be black.



PIP Inset Picture

Main Picture

Setup	EZ Program		
Video	Add/Del/Surf	TO SET	
Audio	EZ Clock	PRESS	
Lock	Captions	ENTER	
Special	Caption/Text		
	Language		
	Source Menu		
	Background		

Main Source	Antenna
PIP Source	Video 1
	✓ Video 2
	F Video
	DVD
	HD
	HD-RGB

▲▼ Move (ENTER) Next (MENU) Back

Use the Source Menu to choose Main screen and PIP sources. *Some sources are not available for PIP and cannot be swapped from the main screen to the PIP inset. See the Source menu page for details.*

Continued on next page.

Mini glossary

TUNER	A device that picks up broadcast signals and turns them into picture and sound.
A/V SOURCE	Other equipment connected to the TV Audio/Video source inputs on the TV back or front connections panel; Video 1, Video 2 etc.

Picture-In-Picture Operation

Using Picture-in-Picture (PIP) features

PIP Inset Picture
Press PIP to turn PIP on and off.

Move PIP Around Screen
Press Right/Left/Up/Down arrows to move the PIP inset to the other corners of the screen.

Main Screen Picture
With PIP off, press FREEZ to place the Main screen picture in the PIP inset and "freeze" the image - turning PIP on. (A good way to freeze the image so you can write down phone numbers etc.)

Main Picture Source
In Main picture channel tuning mode, press SOURCE to change the source to Antenna, Video 1, Video 2, or F Video. (Or, use the Setup Menu.)

Channel/Time/Audio Source Display
Press ENTER to show display. Shows source for: Main picture, and PIP.

Flip Main and PIP Sources
Press SWAP to switch the Main picture source with the PIP inset source.

PIP Inset Source
In PIP channel tuning mode, press SOURCE to change the source for the PIP inset to Antenna, Video 1, Video 2, or F Video. (Or, use the Setup Menu.)

FLASHBK (Flashback)
Returns to the last channel viewed.

ENTER
Shows Channel/Time Display on Main screen.

QUIT
Chooses sound source. (With Channel/Time Display on-screen.)

FREEZ
PIP On: Freezes image in PIP inset.
PIP Off: Freezes Main screen picture in PIP inset and turns PIP on.

SOURCE
Chooses Main screen and PIP picture sources.

Up/Down/Left/Right Ar
Move PIP inset around screen.

SWAP
Switches Main screen picture and sound with PIP picture and sound.

PIP
Turns PIP on and off.

Programming the Remote

Set up your remote to operate other brand name devices

- 1** Turn on the device you want to program.
- 2** On the chart on page 49/50, find the type of device you're programming, and then find the brand name. Make a note of the three-number code, you'll need it soon.
- 3** Press and hold PRG. It's recessed so it doesn't get pushed accidentally. Use a small, blunt object. When the indicator light turns on, you can release PRG.
- 4** Push the key name with the type of device you're programming (VCR, CABLE, AUX, TV).
- 5** Using the NUMBER keypad, enter the three-number code you found on page 49/50.
- 6** Press ENTER to save the code. (The indicator light will flash 3 times, then turn off to indicate the code is valid.)
- 7** Point the remote at the device and push POWER. It should turn off. If not, try the other codes listed and continue from step three.

Note: To reset remote to factory settings, enter 9-1-1, in Step 5.



Programming your Zenith remote may allow you to use one remote to work up to 7 different devices, if all modes are programmed.



Not all devices will work with your Zenith remote control.

Mode / Product Compatibility			
TV	VCR	CATV	AUX (AUX+1, AUX+2, AUX+3)
TVs	VCRs	Cable Boxes, Satellite Receivers	All products on pp 49 - 50

Mini glossary

PROGRAMMING	Procedure to set up remote to operate other equipment.
PRG	Programming mode key.
DEVICE	Infra-red remote controllable electronic accessory equipment.

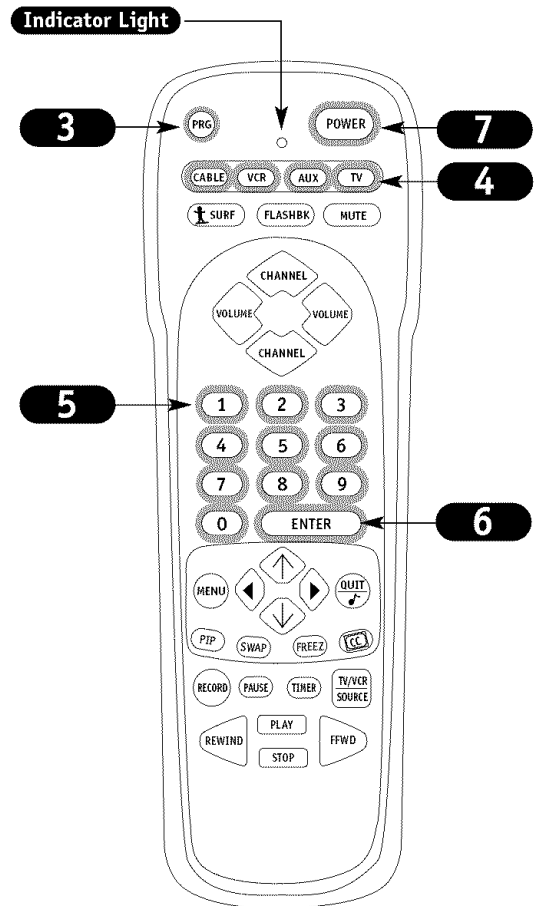

Amplifier Volume Override

Control the volume on your home audio system without changing modes

- 1** Find the code that operates your amplifier. Test it to make sure it's the correct one by following the procedure in "Programming Your Remote", on page 45.
- 2** Program your audio system into one of the available AUX modes: Aux, Aux+1, Aux+2, or Aux+3.
- 3** Press and hold PRG on your remote until the indicator light stays lit, then release.
- 4** Press 4-9-9; then ENTER on the remote. The indicator light will flash three times the code was accepted.
- 5** Audio system volume/mute now appears in all modes. Note: You can also program Cable Box Volume and Mute control (if available) into your cable box mode (CABLE or AUX mode) by repeating the steps for programming on the previous page but entering 3-9-9, instead of a brand code, then pressing ENTER.



To put everything back to normal, reprogram the mode from Step 3 with the original brand code.



If you can't find the code for your amplifier, use the Auto Find feature on page 48.

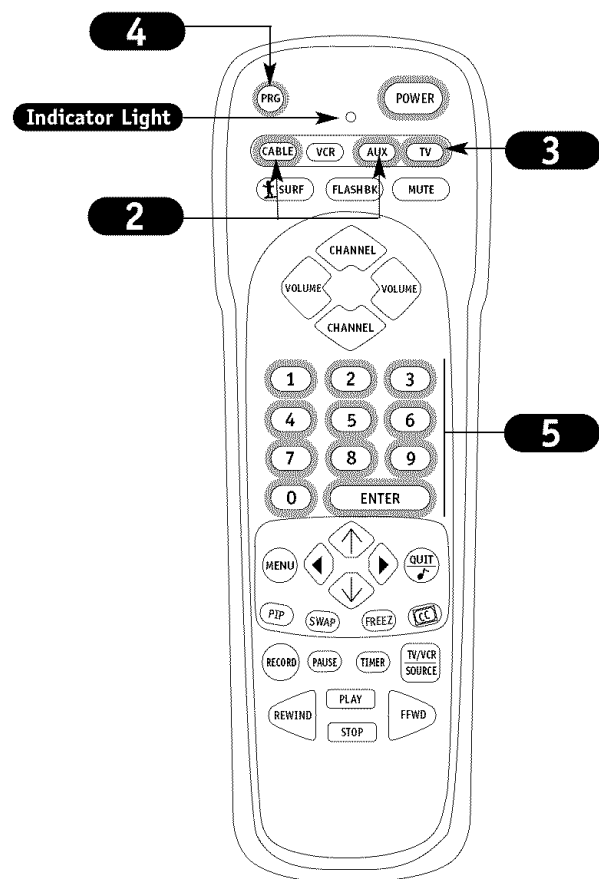

Mini glossary

AMPLIFIER	Audio device which sends sound to speakers, like an Audio Tuner, Receiver, or Amplifier. See Audio Tuners/Amp list on page 50.
CABLE BOX VOLUME/MUTE	Some cable boxes have volume controls.

Control up to seven different devices with your remote

- 1 Refer to the chart on page 49/50 to find the type and brand name of the device you're programming.
- 2 Press and hold PRG until the indicator light turns on, then release PRG.
- 3 Press AUX and the 1 on the NUMBER keypad at the same time (for AUX +1).
- 4 Using the NUMBER keypad, enter the three-number code for the device you've selected.
- 5 Press ENTER to save the code.
- 6 With the device turned on, point the remote at it and press POWER. It should turn off.
- 7 Repeat the steps for AUX+2, and AUX+3.



Programming your Zenith remote may allow you to use one remote to work up to 7 different products or devices.



Some devices may not work with your Zenith remote control.

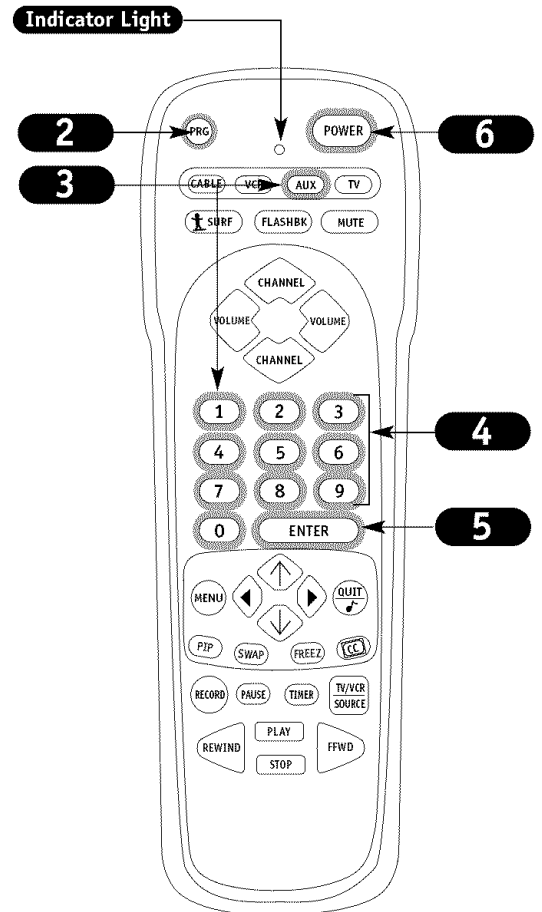

Mini glossary

AUX Auxiliary equipment. Can be any equipment which does not have a dedicated key on your remote like Cable or VCR. Typically a second VCR, stereo system, audio tape deck, etc.

Remote Control Auto Find

Use Auto Find to automatically search and try all possible brand codes

- 1 Turn on the device you want the remote to control.
- 2 Press and hold PRG until the indicator light turns on, then release PRG.
- 3 Press the key for the device you are trying to program (CABLE, VCR, AUX, TV).
- 4 Press 0-0-0 (zero-zero-zero), then press ENTER right away.
- 5 Aim the remote at the correct device and push the POWER key (The indicator light will turn off while the POWER key is pressed). Allow a second to pass, then push the POWER key again. Repeat until the device turns off.
- 6 Push ENTER to save the code (The indicator light will flash 3 times and then turn off).
- 7 Press POWER to turn the device back on.



You can quickly get out of Auto Find by pressing PRG.



If the indicator light stays on while you press Power instead of turning off, all the codes have been tried and your device can't be controlled.

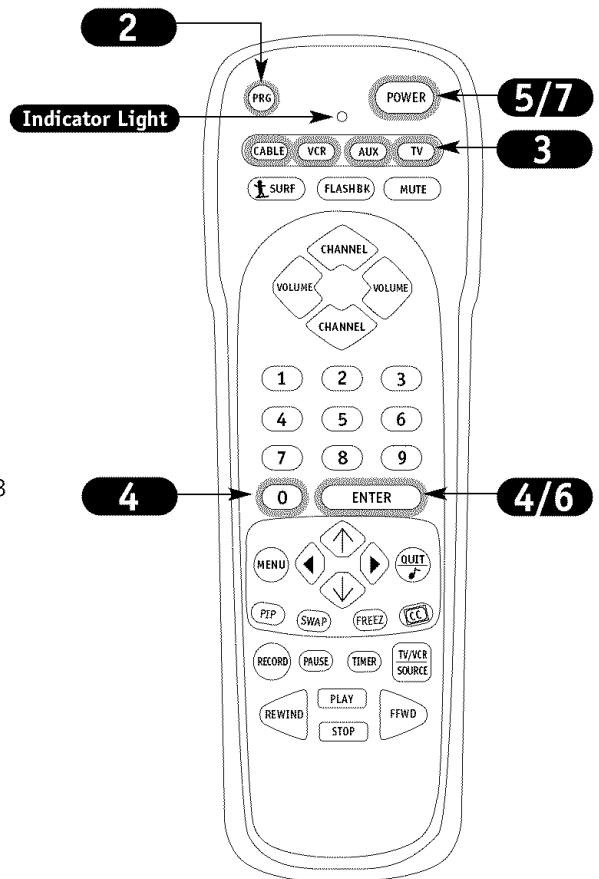

Mini glossary

AUTO FIND Another way of finding a brand code for controlling auxiliary equipment such as a VCR, DVD player, etc. that is not available through the regular remote brand code programming method.

Programming Codes

TVs

Daewoo 149
Zenith 101 121 149 152

TV/VCR Combination Codes

Adventura TV/VCR . 154
Daewoo TV/VCR . . 148

Funai TV/VCR. . . 154
Goldstar TV/VCR. . 153 172
Symphonic TV/VCR 154

Zenith TV/VCR . . . 150 152 153 154
172

VCRs

Admiral 261
Akai 292 717 718 719
720
Audio Dynamics . . 726
Bell & Howell . . . 247
Broksonic 221 250 255 729
Candle 727
Canon 704
Capeheart 728
Citizen 727
Craig 212
Curtis Mathes . . . 259 266 725 727
Daewoo 244 246 248 254
703 729
Daytron 246
DBX 726
Electrochrome. . . 730
Emerson 203 221 243 250
293 721 722 729
730 731 732
Fisher 211 212 213 247
265 274

General Electric . . 216 220 266 282
701 702 725
Go Video 256 262 263 700
Goldstar 253
Harmon Kardon . . . 296
Hitachi 257 270 273 292
705 706 707 708
J.C. Penny 268 726
Jensen 292
JVC 224 225 258 268
292 299 726
Kenwood 268 292 726 727
Magnavox 275
Marantz 267 268 726 727
Memorex 212 298
MGA 297 730
Mitsubishi 276 277 278 279
280 296 297 730
Montgomery Ward . 216 219 249 291
730
MultiTech. 727
NEC 267 268 269 281
292 709 726

Orion 250
Panasonic 245 251 259 713
714 715 716
Pentax 708 727
Philco 275
Pioneer 210 282 726
Portland 246 727
ProScan 216 260 266 282
725
Quasar 259 295
Radio Shack 213 265 730
RCA 216 220 228 240
242 249 260 266
282 283 284 285
286 287 288 708
710 711 725
Realistic 212 213 265 730
Saisho. 722
Salora 297
Samsung 220 230
Sansui 289 292 709 726
Sanyo 212 247 294
Scott 243 290 729

Sears 211 212 213 265
274
Sharp 261 730
Signature 2000 . . . 216 219 249
Sony 232 723 724
Sylvania 275 297
Tatung 268 292
Teac 268
Teknika 272
Toshiba 213 274 290 297
Vector Research . . 726 727
Victor 726
Video Concepts . . . 726 727
XR - 1000 243
Yamaha 726
Zenith 201 224 225 229

Cable Boxes

Allegro 358 362
Allegro A-B Switch 361
Archer 325
Century 325
Citizen 325
Comtronic 326
Everquest. 379
Garrard 325
Gemini 305 331 338
General Electric. . 367
General Instrument 304 305 306 307
308 309 310 318

Hamlin 302 303 345 365
366
Jasco 325
Jerrold 304 307 308 309
310 318 360 363
Kale Vision 335
Macom 321
Magnavox 327 334
NSC 335 339 368 369
370
Oak 311 332 342
Panasonic 313 320
Philips 325 327 347 350

352 354 355
Pioneer 315 343
RCA 341
Regency 329
Samsung 326 335
Scientific Atlanta . 316 323 336 337
364
Signal 326
SL Marx 326
Sprucer 313
Standard Comp . . . 335
Stargate 326 379

Teleview 326
Texscan 339 356 371
Tocom 317 318 346
Unika 325 348 362
Universal 325 358 362
Vid Tech 340
Video Way 349
Viewstar 327 354 355 372
Zenith HT-2000. . . 353
Zenith PM 374

Programming Codes

Satellite Receivers

Alphastar 516	Hughes Network . . 514	RCA 510 517	Toshiba 509 512
Chaparral 501 502	JVC 518	Realistic 506	Uniden 522
Cheyenne 502	Macom 314	Sierra I 502	United 344
Dishnet 515	Magnavox 521	Sierra II 502	Zenith Drake 312 330
Drake 503	Phillips 521	Sierra III 502	Zenith Satellite . . 328 351 378 500
General Electric . . 510 517	PrimeStar 513	Sony 511	
General Instrument 504 505	ProScan 510 517	STS1 507	
Hitachi 519 520	RCA DSS 373	STS3 508	

DVD Players

JVC 965	Pioneer 963	Toshiba 961
Mitsubishi 964	Sony 962	Zenith 960

Audio CD Players

ADC 940	JVC 949 954	Phillips 421 433 434	Soundesign 461 498 901 902
ADO 939	Kenwood 441 931 948	Pioneer 431 435 944	Sylvania 433
Aiwa 938	Luxman 930	Quasar 432	Teac 418 419
Akai 937	Magnavox 421 422 433 434	Radio Shack 431 441	Technics 432
Denon 935	Marantz 929 947	RCA 437 943	Toshiba 915
Dynatech 953	MCS 928	Sanyo 438 439	Yamaha 414 941 942
Emerson 952	Mitsubishi 927	Sears 936	Zenith 460 461 498 901 902
Fisher 438 933 951	Nakamichi 925 926	Sharp 441 442	Zenith CD Recorder 415
GE 932	Onkyo 923 924 946	Sherwood 449	
Goldstar 460	Optimus 920 921 922	Sony 420 443 444 445 934	
Hitachi 950	Panasonic 431 432 945		

Audio Tape Decks

Sony 452

Audio Tuners/Amps

Citizen 914	Marantz 903 913	Pioneer 470 485 907	Soundesign 461 498 901 902
GE 916	Memorex 485	Proton 910	Techniques 912
Goldstar 460 474	Nad 904	Quasar 912	Toshiba 915
Hitachi 919	Nakamichi 493	RCA 909	Victor 908
JVC 908	Onkyo 471 906	Sharp 483 917 918	Zenith 460 461 498 901 902
Kenwood 484	Optimus 905	Sherwood 900	
Luxman 467	Panasonic 912	Sony 486 489 490 491 492	

HD/Set Top Boxes

EchoStar 805	Philips 802	Sony 801
Hughes 803	RCA 804	Zenith 800

Remote Key Functions By Mode

A complete list of key functions for your remote control

KEY NAME	TV Mode Z	VCR Mode	Cable Mode	AUX Mode
POWER	TV On/Off	VCR On/Off	Cable Box On/Off	AUX TV/DISC
CABLE	Selects Cable	Selects Cable	Selects Cable	Selects Cable
VCR	Selects VCR	Selects VCR	Selects VCR	Selects VCR
AUX	Selects Aux	Selects AUX	Selects Aux	Selects AUX
TV	Selects TV	Selects TV	Selects TV	Selects TV
SURF	Surf On/Off	VCR AM/PM	CABLE FC Fav Ch	AUX Audio
FLASHBK	TV Flashback	VCR Flashback	Cable Flashback	AUX Frame/Time
MUTE	TV Mute	TV Mute	TV Mute	TV Mute
CHANNEL UP	TV Channel Up	VCR Channel Up	Cable Channel Up	AUX Skip >>
CHANNEL DN	TV Channel Dn	VCR Channel Dn	Cable Channel Dn	AUX Skip <<
VOLUME (RIGHT)	TV Volume Up	TV Volume Up	TV Volume Up	TV Volume Up
VOLUME (LEFT)	TV Volume Dn	TV Volume Dn	TV Volume Dn	TV Volume Dn
1	TV Digit 1	VCR Digit 1	Cable Digit 1	AUX Digit 1
2	TV Digit 2	VCR Digit 2	Cable Digit 2	AUX Digit 2
3	TV Digit 3	VCR Digit 3	Cable Digit 3	AUX Digit 3
4	TV Digit 4	VCR Digit 4	Cable Digit 4	AUX Digit 4
5	TV Digit 5	VCR Digit 5	Cable Digit 5	AUX Digit 5
6	TV Digit 6	VCR Digit 6	Cable Digit 6	AUX Digit 6
7	TV Digit 7	VCR Digit 7	Cable Digit 7	AUX Digit 7
8	TV Digit 8	VCR Digit 8	Cable Digit 8	AUX Digit 8
9	TV Digit 9	VCR Digit 9	Cable Digit 9	AUX Digit 9
0	TV Digit 0	VCR Digit 0	Cable Digit 0	AUX Digit 0
ENTER	TV Enter	VCR Enter	Cable Enter	Aux Display
MENU	TV Menu	VCR Menu	Cable Menu	AUX Program
UP ARROW	TV Select Up	VCR Select Up	Cable Up Arrow	AUX Part
DOWN ARROW	TV Select Dn	VCR Select Dn	Cable Dn Arrow	AUX Random
LEFT ARROW	TV Adjust Left	VCR Adjust Left	Cable Left Arrow	AUX x3 FAST <
RIGHT ARROW	TV Adjust Right	VCR Adjust Right	Cable Right Arrow	AUX x3 FAST >
QUIT	TV Surr Sound	VCR Quit	Cable Quit	AUX Clear
PIP	TV PIP	VCR+	Day Up	AUX Repeat-Side
SWAP	TV PIP Swap	VCR Channel Map	Day Down	AUX Repeat-A-B
FREEZ	TV PIP Freeze	VCR Search	Cable Pg Up	AUX Repeat-Chap
CC	TV Closed Captions	VCR Memory	Cable Pg Down	AUX Memory
TIMER	TV Timer	VCR Timer	Cable Timer	AUX Still
TV/VCR/SOURCE	TV Sources	TV Tuner or VCR Tuner	Cable Info	AUX TV/Disc
RECORD	VCR Record	VCR Record	Cable Buy	AUX Edit
PAUSE	VCR Pause	VCR Pause	Cable Guide	AUX Pause
REWIND	VCR Rewind	VCR Rewind	VCR Rewind	AUX Scan <<
PLAY	VCR Play	VCR Play	VCR Play	AUX Play
STOP	VCR Stop	VCR Stop	VCR Stop	AUX Stop/Eject
FFWD	VCR Fast Forward	VCR Fast Forward	VCR Fast Forward	AUX Scan >>



Some of the functions shown above may not be available on your equipment.

Routine TV cabinet and screen cleaning

Careful and regular cleaning can extend the the useful service life of the TV. Be sure to turn the power off and pull out the plug before you begin any cleaning.

Screen Cleaning

1. Here's a great way to keep the dust off the screen for a while. Wet a soft cloth in a mixture of lukewarm water and a little fabric softener or dish washing detergent. Wring the cloth until it's almost dry, and then use it to wipe the screen.
2. Make sure the excess water is off the screen, and then let it air-dry before turning the TV on.

Cabinet Cleaning

1. Use a soft cloth with a mild soap solution to wipe the cabinet. (Don't use any harsh, industrial strength variety of cleaner.)
2. Rinse the cloth and wipe the cabinet again.
3. Let the cabinet air-dry before turning the TV on.

Wood Cabinet

Use a quality wood cleaner and polish. This will protect the TV from dirt and dust, as well as keep the cabinet looking new.

Extended Absence

If you leave your TV dormant (Off) for a long time (such as a vacation), it's a good idea to unplug the power cord to protect against possible damage from lightning or power surges. If you use an off-air antenna, you may also want to disconnect it from the back of your TV before leaving.



If you unplug the TV, you may have to reset the clock using the Clock Set menu described earlier. See page 24.

Troubleshooting

Some quick and easy tips to resolving problems

Symptoms	Possible Cause(s)	Possible Solution(s)	See page(s)
Power			
No Power.	<ul style="list-style-type: none"> • AC Power Cord not connected. • Local power failure? 	<ul style="list-style-type: none"> -Connect power cord. Try a different household outlet. -Contact power company for information. 	7 - 14
No Source image.	<ul style="list-style-type: none"> • Source turned off. • Source not selected. 	<ul style="list-style-type: none"> -Turn Source equipment on. -Use SOURCE to choose desired picture and sound source. 	17 17
Picture Reception			
Poor or no picture.	<ul style="list-style-type: none"> • TV station problems. • Video menu not adjusted properly. 	<ul style="list-style-type: none"> -Try a different channel. -Check Video menu option settings. 	16/17 29
Local interference.	<ul style="list-style-type: none"> • Check for disturbing source. • Appliance too close to TV. 	<p><i>The following may cause image problems or distortion: Electrical appliances, powerful lights, cars, trucks; computers or portable phones; medical equipment; VCR to close to TV, etc.</i></p> <ul style="list-style-type: none"> -If possible increase the distance between your Entertainment Machine and the offending appliance. Or shut one of them off. 	
Poor or no color.	<ul style="list-style-type: none"> • Sub-standard broadcast. • Sub-standard cable signal. 	<ul style="list-style-type: none"> -Try a different channel. -Notify cable company of reception problem. 	16/17
Picture wobbles or drifts.	<ul style="list-style-type: none"> • CATV wire not connected or loose. • Local interference. • Scrambled CATV channel. 	<ul style="list-style-type: none"> -Make or tighten connection. -Try different channel. Turn off interfering appliance. -Tune to unscrambled channel. 	8/10 16/17 16/17
No CATV reception.	<ul style="list-style-type: none"> • Cable wire not connected. • Cable service interrupted. • Antenna set, not Cable (CATV). 	<ul style="list-style-type: none"> -Connect cable to Antenna/Cable. -Contact cable service. -Select Cable in EZ Program menu. 	8/10 18
Images in picture distorted.	<ul style="list-style-type: none"> • Wrong aspect ratio. 	<ul style="list-style-type: none"> -Use RATIO to change picture proportion. 	30
Poor or no sound.	<ul style="list-style-type: none"> • Audio muted. • Broadcast problem. 	<ul style="list-style-type: none"> -Press MUTE or VOL (Volume) + key to increase sound level. -Tune to a different channel. 	17
TV turns On.	<ul style="list-style-type: none"> • On-Timer turned TV On. 	<ul style="list-style-type: none"> -Cancel On-Timer and/or turn TV off. 	36
TV turns Off.	<ul style="list-style-type: none"> • Sleep Timer turned TV Off. • Off-Timer turned TV off. 	<ul style="list-style-type: none"> -Turn TV back on. -Cancel Off-Timer and /or turn TV off. 	35 36
No Closed Captions or Text.	<ul style="list-style-type: none"> • Not available on show. • Not turned on. 	<ul style="list-style-type: none"> -Check local TV listings to see if available on broadcast. -Check the Captions menu to Off. -Try a different channel with Closed Captions or Text. -Pick a Closed Caption or Text option and turn Captions on. 	16/17 25
Captions appear when sound is muted.	<ul style="list-style-type: none"> • EZ Mute selected. 	<ul style="list-style-type: none"> -Set Captions option to off. 	25
Lock (Parental Control) Problems			
Protected by Lock appears on screen.	<ul style="list-style-type: none"> • Viewing is restricted by Lock. • Don't know password. 	<ul style="list-style-type: none"> -Key-in password and turn Lock On/Off (Restrictions) off. Set indiv -Set Lock On/Off option to Off in Lock menu. -Tune to channel without Lock "Content" restrictions. 	32/33/34

Continued on next page.

Troubleshooting (Continued)

Some quick and easy tips to resolving problems

Symptoms	Possible Cause(s)	Possible Solution(s)	Page(s)
Using Remote Control			
Remote does not work.	• Wrong mode selected.	-Press correct mode key to change mode (TV for TV operation.)	17
	• Not aimed at remote sensor.	-Point remote at Front Control Panel.	16
	• Remote too far from TV or too much light in room.	-Move remote closer to TV or darken room.	
	• IR path to TV interrupted.	-Remove obstructions.	
	• Weak batteries.	-Replace batteries.	7
Remote does not operate accessory product.	• Wrong battery polarity.	-Check that "+" and "-" match in battery compartment.	7
	• Product Mode not programmed.	-Program for other equipment: VCR, AUX, etc.	
	• Product not IR controlled.	-Remote only controls IR equipment.	
Menu Operation			
Menu options can't be changed or selected.	• Software lock-up.	-Unplug power cord for 5 minutes to unlock software. (Reset clock if necessary.)	7
Timers do not work.	• "Off" selected on menu.	-Choose "On" to make timer(s) work.	36
	• Clock not set.	-Set clock.	24
Clock is set, or sets itself, to Wrong Time			
Clock time is wrong.	• Wrong Time Zone.	-Reset to your time zone.	24
	• Daylight Savings Time wrong.	-If not observed in your area, set to Off.	24
	• Time does not set automatically.	-Set clock manually.	24
	• Auto Clock doesn't work.	-Turn Auto Clock option "Off" in menu, set clock manually.	24
Picture Viewing Problems			
Image looks wrong.	• Wrong Video Menu Aspect Ratio.	-Use correct aspect ratio for source's image.	30
Snowy or Poor Picture	• Wrong Ant. connection/location.	-Move antenna, check connection/location.	
	• TV/VCR button set wrong.	-Check cable input.	
	• Wrong tuning mode.	-Set TV/VCR button on your VCR correctly.	9/10/11
	• Wrong output channels selected.	-Are you in TV or cable tuning mode, and should be in the other?	
	• Loose connection.	-Make sure same channel (3 or 4).	9/10/11
		-Check that all connections are tight.	
Picture has a big black box on it, but the sound is O.K.	• Caption/Text mode turned on.	-The CC (closed caption) option may be in Text 1, 2, 3, or 4 mode.	
No picture.		-Select Caption 1, or OFF in the Caption/Text menu.	25
	• AC power not plugged in?	-Plug AC power cord in.	7
	• AC power outlet doesn't work.	-Check that your AC power outlet works. (Test it by plugging in something else or try another outlet.)	
	• Menu options set wrong.	-Make sure brightness controls are set properly.	29
	• Broadcast problem.	-Try another channel.	16/17

Troubleshooting (Continued)

Symptoms	Possible Cause(s)	Possible Solution(s)	Page(s)
Sound/Audio Problems			
Normal picture but no sound.	<ul style="list-style-type: none">• Check volume levels.• Try another channel.• A/V cables incorrectly connected.• Audio Out cables installed wrong.• Speakers turned off.• No SAP signal.	<ul style="list-style-type: none">-Make sure the TV sound is not muted.-The problem may be the broadcast, not your TV.-Install the Audio cables correctly.-Install external amplifier cables correctly.-Turn speakers on in the Audio menu.-If the Audio Mode is set to SAP, the channel may not have an SAP program.	17 16/17
HD/DVD Problems			
Picture looks wrong.	<ul style="list-style-type: none">• Wrong Video menu Aspect Ratio.	<ul style="list-style-type: none">-Use correct aspect ratio for source's image.	30
No picture or sound.	<ul style="list-style-type: none">• Wrong source selected on TV.• Source equipment turned off.• Tape or Disk not playing.• Wires incorrectly connected.	<ul style="list-style-type: none">-Select correct source equipment.-Turn source equipment on.-Press "PLAY" on source equipment.-Install wires correctly on TV and equipment.	17 7 - 14
No HD-RGB sound.	<ul style="list-style-type: none">• Audio cables not connected to HD-In R-L Audio.	<ul style="list-style-type: none">-Connect RGB audio to HD-In R-L Audio.	14

A list of definitions for some of the words found in this guide

75 OHM RF CABLE	The wire that comes from an off-air antenna or cable service provider. The end looks like a hex-shaped nut with a wire sticking through the middle. It screws onto the threaded jack on the back of the TV.
300 TO 75 OHM ADAPTER	A small device that connects a two-wire 300 ohm antenna to a 75 ohm RF jack. They are usually about an inch long with two screws on one end and a round opening with a wire sticking out on the other end.
A/V CABLES	Audio/Video cables. Three cables bunched together—right audio (red), left audio (white), and video (yellow). A/V cables are used for stereo playback of videocassettes and for higher quality picture and sound from other A/V devices.
A/V DEVICE	Any device that produces video or sound (VCR, DVD, cable box, or television).
ADDED	Lets you add new channels to channel scan list that you'll scroll through.
AMPLIFIER	An electronic device that amplifies sound from a television, CD player, VCR, DVD or other A/V equipment.
ANTENNA	The physical receiver of television signals sent over the air. A large metal piece of equipment does not always have to be visible for your home to be using an antenna.
DELETED	Lets you remove channels from the channel scan list that you'll scroll through.
EZ PROGRAM	Auto Program (channel search) automatically finds the channels available in your area.
INPUT	Refers to the jack that receives a signal from a TV, VCR or other A/V device.
JACK	An input or output connection on the back of a TV, VCR, or other A/V device.
MONO SOUND	Mono (monaural) sound is one channel of sound. With more than one speaker, all the speakers play the same audio.
OUTPUT	Refers to the jack that sends a signal out of a VCR, DVD, or other A/V device.
2ND AUDIO PROGRAMMING/SAP	Second Audio Programming (SAP) is another, separate, audio channel available with some programming. Choosing SAP often refers to listening to audio in another language, such as Spanish or French.
SIGNAL	Picture and sound traveling through a cable, or over the air, to your television screen.
STEREO SOUND	Stereo (Stereophonic) sound refers to audio that's divided into right and left sides.
TUNER	Device that picks up the signal and turns it into picture and sound.

Zenith HDTV Monitor Warranty



Zenith will repair or replace your product, at Zenith's option, if it proves to be defective in material or workmanship under normal use, during the warranty period listed below from the date of original consumer purchase. **This warranty is available only to the original, end user purchaser of the product and effective only when used in the United States, excluding U.S. Territories. Zenith is not responsible for deinstallation or reinstallation of unit.**

WARRANTY PERIOD:	HOW SERVICE IS HANDLED:
Labor: 90 Days from date of purchase.	In-Home service: At no charge At no charge to you. Please call 1-877-9Zenith (1-877-993-6484) to locate your nearest Zenith Authorized Service Center. Repair parts or a replacement may be new or remanufactured. Please see below for further information.
Parts: One Year from the date of purchase. Picture tube two years.	

THIS WARRANTY IS IN LIEU OF ANY OTHER WARRANTY, EXPRESSED OR IMPLIED, INCLUDING WITHOUT LIMITATION, ANY WARRANTY OF MERCHANTABILITY OR FITNESS FOR A PARTICULAR PURPOSE. TO THE EXTENT ANY IMPLIED WARRANTY IS REQUIRED BY LAW, IT IS LIMITED IN DURATION TO THE EXPRESSED WARRANTY PERIOD ABOVE. ZENITH WILL NOT BE LIABLE FOR ANY INCIDENTAL, CONSEQUENTIAL, INDIRECT, SPECIAL OR PUNITIVE DAMAGES OF ANY NATURE, EVEN IF ADVISED OF THE POSSIBILITY OF SUCH DAMAGES, INCLUDING WITHOUT LIMITATION LOST PROFITS, LOST OR CORRUPTED PROGRAMMING OR DATA, OR ANY OTHER DAMAGE WHETHER BASED IN CONTRACT, TORT OR OTHERWISE. Some states do not allow the exclusion or limitation of incidental or consequential damages or limitations on how long an implied warranty lasts, so the above exclusion or limitation may not apply to you. This warranty gives you specific legal rights and you may also have other rights that vary from state to state.

THIS LIMITED WARRANTY DOES NOT APPLY:

- To damages or operating problems that result from shipping, installation, adjustment of user controls, calibration, maintenance or failure to maintain, or separate system components.
- To damages or operating problems that result from normal wear and tear, misuse, abuse, operation outside environmental specifications or contrary to the requirements and precautions in the Operating Guide, accident, lightning strikes or other natural causes, modification or alteration, incorrect electrical current or voltage, signal reception or input, computer software, or institutional or commercial use.

Therefore, you pay for the cost of repair or replacement under these circumstances.

CUSTOMER ASSISTANCE NUMBERS:

To prove warr

Retain your dated sales receipt to prove date of purchase. Legible copy of your sales receipt must be submitted at the time warranty service is provided.

To obtain where-to-buy, nearest Authorized Service Center, product assistance or customer assistance:

Call 1-877-9Zenith (1-877-993-6484) (Mon. - Fri. 7:00 AM to 8:00 PM and Sat. 8:00 AM to 5:00 PM CST)
Please select the appropriate option from the menu.