

Installation Instructions



PH1Z024-060 Packaged Heat Pump Units

7-03

NOTE: Read the entire instruction manual before starting the installation.

TABLE OF CONTENTS

SAFETY CONSIDERATIONS.....	2
INTRODUCTION.....	2
RECEIVING AND INSTALLATION.....	6
Check Equipment.....	6
IDENTIFY UNIT.....	6
INSPECT SHIPMENT.....	6
Provide Unit Support.....	6
SLAB MOUNT.....	6
GROUND MOUNT.....	6
Provide Clearances.....	6
Place Unit.....	6
Select and Install Ductwork.....	6
INSTALL FLANGES FOR DUCTWORK CONNECTIONS (PH1Z060 ONLY).....	6
CONVERTING HORIZONTAL DISCHARGE UNITS TO DOWNFLOW (VERTICAL) DISCHARGE.....	7
Provide for Condensate Disposal.....	7
Install Electrical Connections.....	9
HIGH-VOLTAGE CONNECTIONS.....	9
ROUTING POWER LEADS INTO UNIT.....	9
CONNECTING GROUND LEAD TO UNIT GROUND.....	10
ROUTING CONTROL POWER WIRES.....	10
ACCESSORY ELECTRIC HEAT WIRING.....	10
SPECIAL PROCEDURES FOR 208-V OPERATION.....	11
PRE-START-UP.....	11
START-UP.....	12
Check for Refrigerant Leaks.....	12
LOCATE AND REPAIR REFRIGERANT LEAKS AND CHARGE THE UNIT AS FOLLOWS:.....	12
Start-Up Cooling Section and Make Adjustments.....	12
CHECKING COOLING CONTROL OPERATION.....	12
COMPRESSOR ROTATION.....	13
Refrigerant Charge.....	13
NO CHARGE.....	13
LOW CHARGE COOLING.....	13
TO USE THE COOLING CHARGING CHART.....	13
HEATING MODE CHARGE.....	13
Indoor Airflow and Airflow Adjustments.....	13
FOR 208/230-V.....	14
FOR 460-V MOTORS.....	14
Unit Controls.....	15
HIGH-PRESSURE RELIEF VALVE.....	15
LOSS OF CHARGE SWITCH.....	15
COMPRESSOR OVERLOAD.....	15
Sequence of Operation.....	15
FAN OPERATION.....	15
COOLING.....	15
HEAT PUMP HEATING.....	15
DEFROST.....	17
ELECTRIC RESISTANCE HEATING.....	17

MAINTENANCE.....	17
Air Filter.....	19
Unit Top Removal (Outdoor-Coil Side).....	19
Indoor Blower and Motor.....	19
Outdoor Coil, Indoor Coil, and Condensate Drain Pan.....	20
Outdoor Fan.....	21
Electrical Controls and Wiring.....	21
Refrigerant Circuit.....	22
Indoor Airflow.....	22
Metering Devices.....	22
Lubrication.....	22
Liquid Line Strainer.....	22
High Flow Valves.....	22
TROUBLESHOOTING.....	26
START-UP CHECKLIST.....	27
NOTE TO INSTALLER—Before installation, READ THESE INSTRUCTIONS CAREFULLY AND COMPLETELY. Also, make sure the User's Manual and Replacement Guide are left with the unit after installation.	

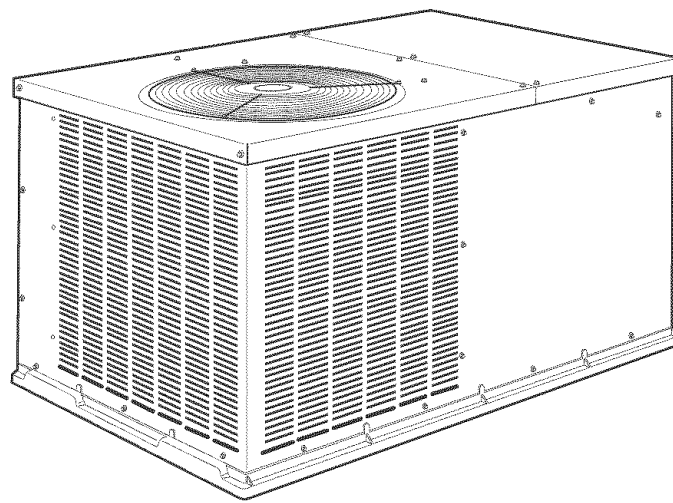

C00155

Fig. 1—Unit PH1Z

SAFETY CONSIDERATIONS

Installation and servicing of air-conditioning equipment can be hazardous due to system pressure and electrical components. Only trained and qualified workers should install, repair, or service air-conditioning equipment.

Untrained workers can perform basic maintenance functions of cleaning coils and filters. All other operations should be performed by trained service people. When working on air-conditioning equipment, pay attention to precautions in the literature, tags, and labels attached to the unit, and other safety precautions that may apply.

Follow all safety codes. Wear safety glasses and work gloves. Use quenching cloth for unbrazing operations. Have fire extinguisher available for all brazing operations.

⚠ WARNING: Before performing service or maintenance operations on system, turn off main power to unit and install lockout tag. Turn off accessory heater power switch if applicable. Electrical shock can cause serious injury or death.

Recognize safety information. This is the safety-alert symbol **⚠**. When you see this symbol in instructions or manuals, be alert to the potential for personal injury.

Understand the signal words DANGER, WARNING, CAUTION, and NOTE. These words are used with the safety-alert symbol. DANGER identifies the most serious hazards which **will** result in severe personal injury or death. WARNING signifies a hazard which **could** result in personal injury or death. CAUTION is used to identify unsafe practices which **would** result in minor personal injury or product and property damage. NOTE is used to highlight suggestions which **will** result in enhanced installation, reliability, or operation.

These instructions cover minimum requirements and conform to existing national standards and safety codes. In some instances, these instructions exceed certain local codes and ordinances, especially those that may not have kept up with changing residential construction practices. We require these instructions as a minimum for a safe installation.

INTRODUCTION

PH1Z heat pump units are fully self-contained and designed for outdoor installation (See Fig. 1). As shown in Fig. 2-4, units are shipped in a horizontal-discharge configuration for installation on a ground-level slab. All units can be field-converted to downflow discharge configurations for rooftop applications with a field-supplied plenum.

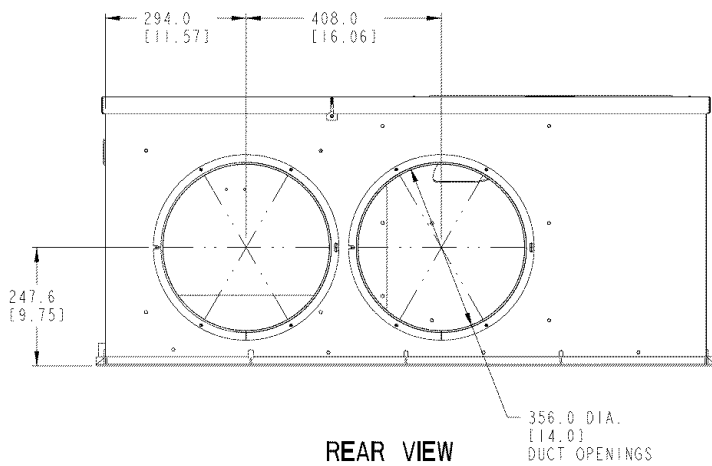

REQUIRED CLEARANCE TO COMBUSTIBLE MATL.

	INCHES [mm]
TOP OF UNIT.....	0
DUCT SIDE OF UNIT.....	42.00 [1066.8]
SIDE OPPOSITE DUCTS.....	0
BOTTOM OF UNIT.....	0

NEC. REQUIRED CLEARANCES.

	INCHES [mm]
BETWEEN UNITS, POWER ENTRY SIDE.....	42.00 [1066.8]
UNIT AND UNGROUNDED SURFACES, POWER ENTRY SIDE.....	36.00 [914.0]
UNIT AND BLOCK OR CONCRETE WALLS AND OTHER GROUNDED SURFACES, POWER ENTRY SIDE.....	42.00 [1066.8]

REQUIRED CLEARANCE FOR OPERATION AND SERVICING

	INCHES [mm]
CONDENSER COIL ACCESS SIDE.....	30.00 [762.0]
POWER ENTRY SIDE.....	30.00 [762.0]
(EXCEPT FOR NEC REQUIREMENTS)	
UNIT TOP.....	48.00 [1219.2]
SIDE OPPOSITE DUCTS.....	30.00 [762.0]

LEGEND

NEC – National Electrical Code

NOTES:

- Clearances must be maintained to prevent recirculation of air from outdoor-fan discharge, with the exception of the condenser coil (36.00 in [914.0 mm]. A removable fence or barricade requires no clearance.
- Dimensions are in inches. Dimensions in [] are in millimeters.

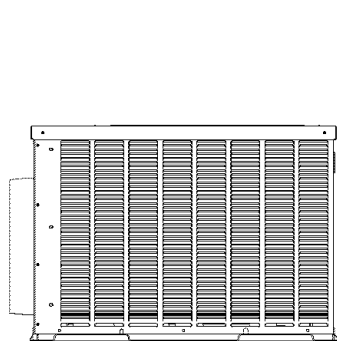
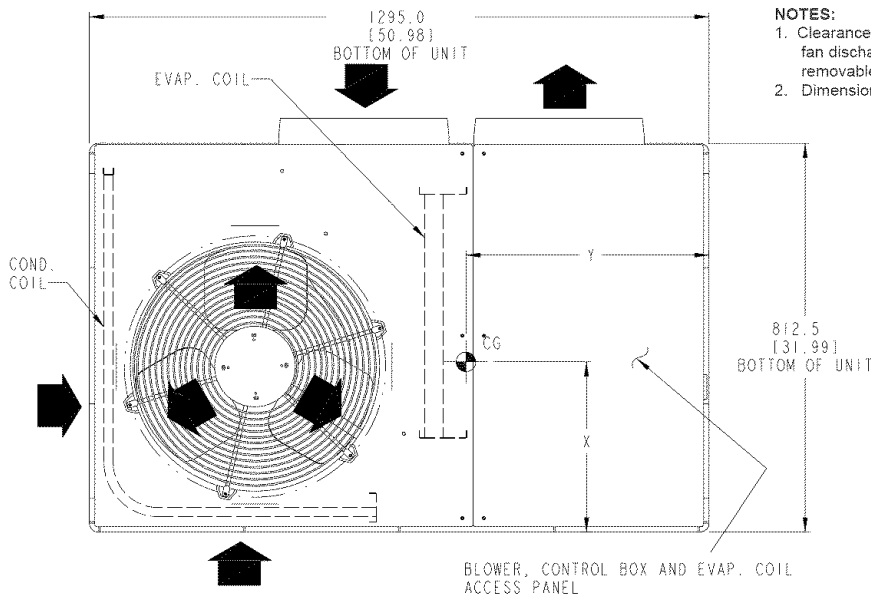

LEFT SIDE VIEW

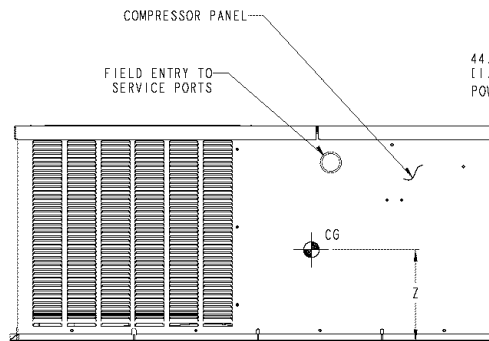

FRONT VIEW

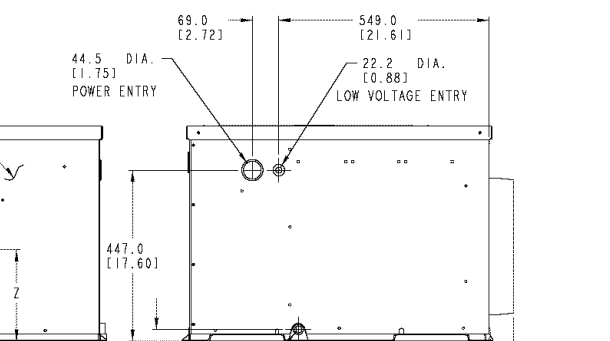

RIGHT SIDE VIEW

C00156

UNIT	ELECTRICAL CHARACTERISTICS	UNIT WEIGHT		CENTER OF GRAVITY IN. (MM)		
		lb	kg	X	Y	Z
PH1Z024	208/230-1-60	232	106	14.0 (356)	19.0 (483)	12.0 (305)
PH1Z030	208/230-1-60, 208/230-3-60	254	116	14.0 (356)	19.0 (483)	12.0 (305)

Fig. 2—Unit Base Dimensions, PH1Z024-030

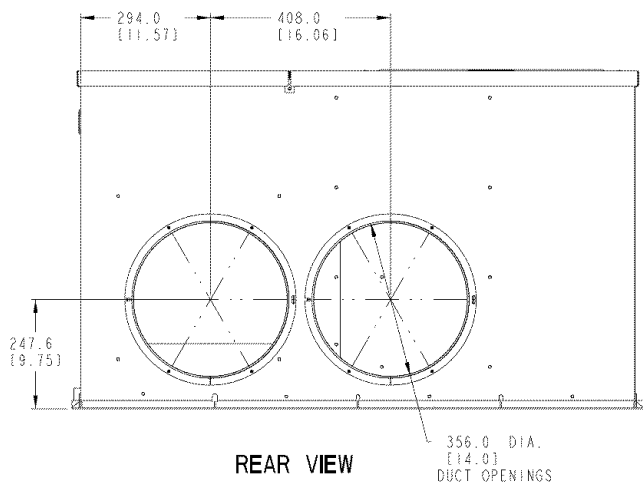

REQUIRED CLEARANCE TO COMBUSTIBLE MATL.

	INCHES [mm]
TOP OF UNIT	0
DUCT SIDE OF UNIT	0
SIDE OPPOSITE DUCTS	0
BOTTOM OF UNIT	0

NEC. REQUIRED CLEARANCES.

	INCHES [mm]
BETWEEN UNITS, POWER ENTRY SIDE	42.00 [1066.8]
UNIT AND UNGROUNDED SURFACES, POWER ENTRY SIDE	36.00 [914.0]
UNIT AND BLOCK OR CONCRETE WALLS AND OTHER GROUNDED SURFACES, POWER ENTRY SIDE	42.00 [1066.8]

REQUIRED CLEARANCE FOR OPERATION AND SERVICING

	INCHES [mm]
CONDENSER COIL ACCESS SIDE	30.00 [762.0]
POWER ENTRY SIDE (EXCEPT FOR NEC REQUIREMENTS)	30.00 [762.0]
UNIT TOP	48.00 [1219.2]
SIDE OPPOSITE DUCTS	30.00 [762.0]

LEGEND

NEC – National Electrical Code

NOTES:

- Clearances must be maintained to prevent recirculation of air from outdoor-fan discharge, with the exception of the condenser coil (36.00 in [914.0 mm]). A removable fence or barricade requires no clearance.
- Dimensions are in inches. Dimensions in [] are in millimeters.

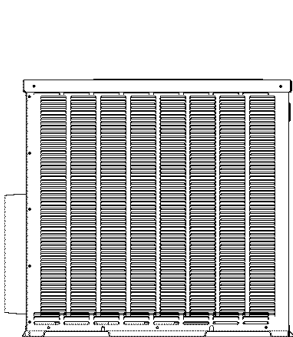
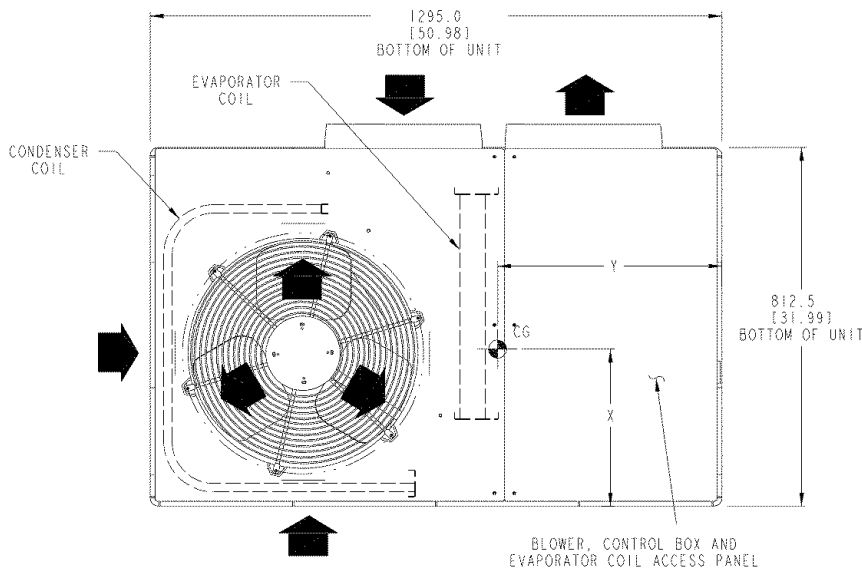

LEFT SIDE VIEW

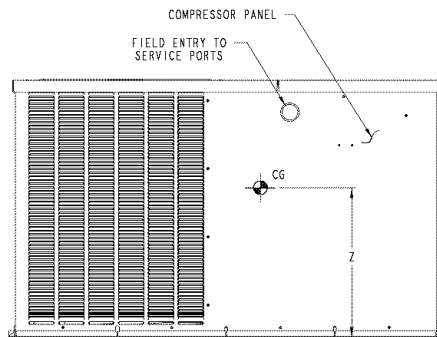

FRONT VIEW

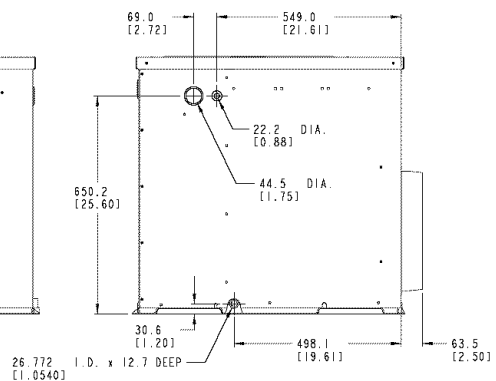

RIGHT SIDE VIEW

C00003

UNIT	ELECTRICAL CHARACTERISTICS	UNIT WEIGHT		CENTER OF GRAVITY IN. (MM)		
		lb	kg	X	Y	Z
PH1Z036	208/230-1-60, 208/230-3-60, 460-3-60	277	126	14.0 (356)	19.0 (483)	15.0 (381)
PH1Z042	208/230-1-60, 208/230-3-60, 460-3-60	295	134	14.0 (356)	19.0 (483)	15.0 (381)
PH1Z048	208/230-1-60, 208/230-3-60, 460-3-60	328	149	14.0 (356)	19.0 (483)	15.0 (381)

Fig. 3—Unit Base Dimensions, PH1Z036–048

DIMENSIONS IN [] ARE IN INCHES

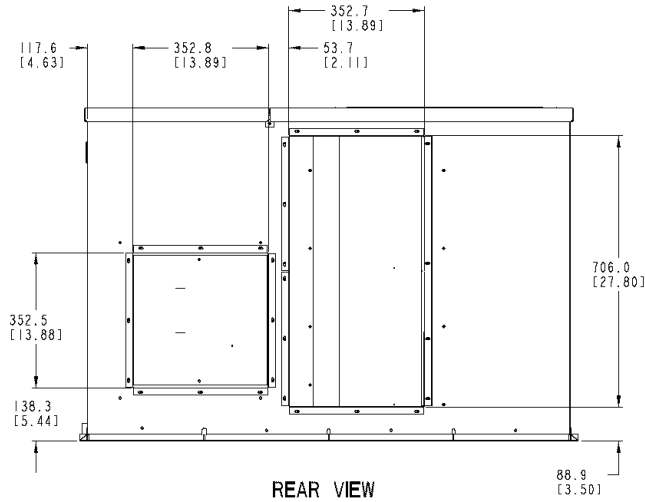

REQUIRED CLEARANCE TO COMBUSTIBLE MATL.

	INCHES [mm]
TOP OF UNIT	0
DUCT SIDE OF UNIT	0
SIDE OPPOSITE DUCTS	0
BOTTOM OF UNIT	0

NEC. REQUIRED CLEARANCES.

	INCHES [mm]
BETWEEN UNITS, POWER ENTRY SIDE	42.00 [1066.8]
UNIT AND UNGROUNDED SURFACES, POWER ENTRY SIDE	36.00 [914.0]
UNIT AND BLOCK OR CONCRETE WALLS AND OTHER GROUNDED SURFACES, POWER ENTRY SIDE	42.00 [1066.8]

REQUIRED CLEARANCE FOR OPERATION AND SERVICING

	INCHES [mm]
CONDENSER COIL ACCESS SIDE	30.00 [762.0]
POWER ENTRY SIDE (EXCEPT FOR NEC REQUIREMENTS)	30.00 [762.0]
UNIT TOP	48.00 [1219.2]
SIDE OPPOSITE DUCTS	30.00 [762.0]

LEGEND

NEC – National Electrical Code

NOTES:

- Clearances must be maintained to prevent recirculation of air from outdoor-fan discharge, with the exception of the condenser coil (36.00 in [914.0 mm]). A removable fence or barricade requires no clearance.
- Dimensions are in inches. Dimensions in [] are in millimeters.

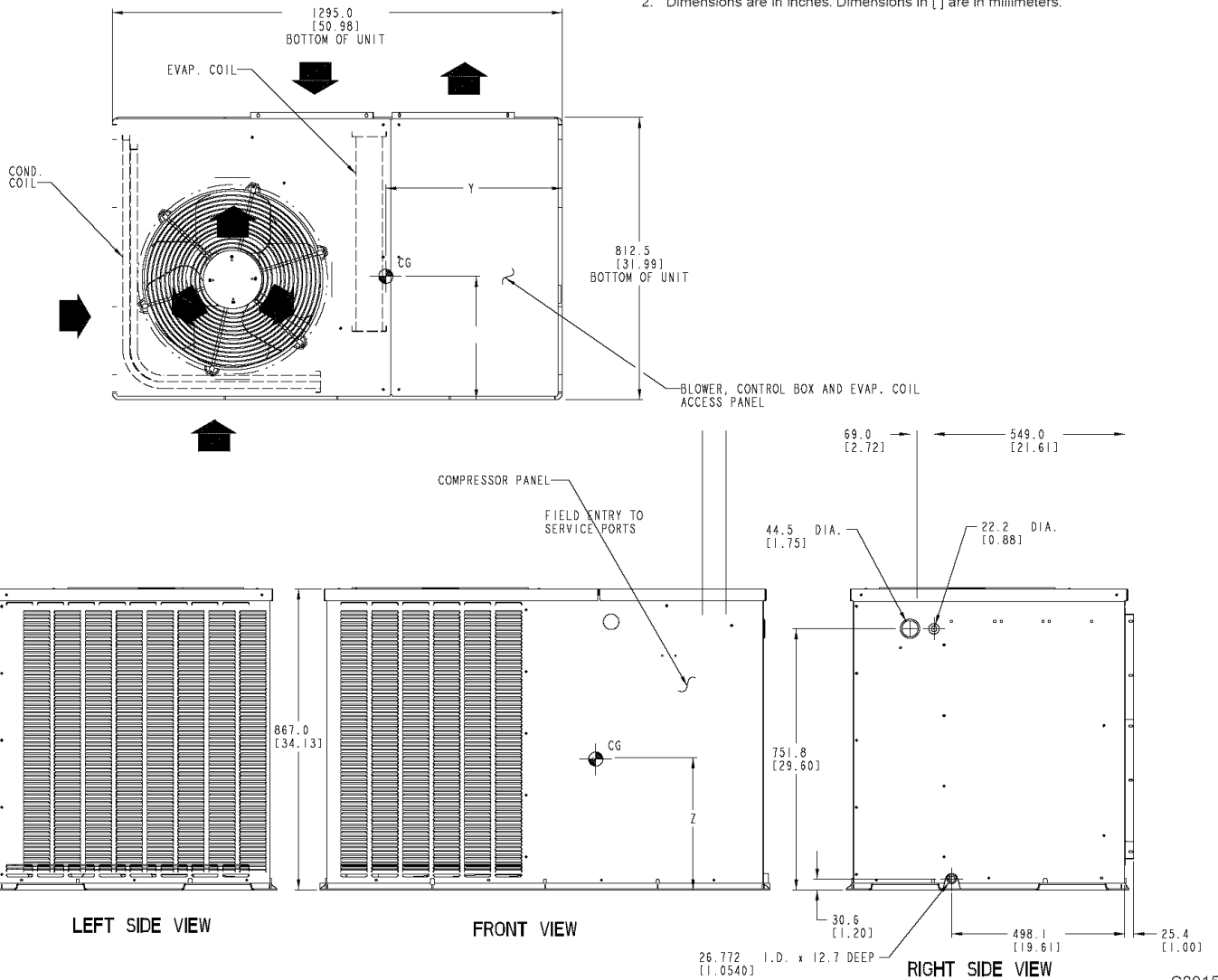

C00158

UNIT	ELECTRICAL CHARACTERISTICS	UNIT WEIGHT		CENTER OF GRAVITY IN. (MM)		
		lb	kg	X	Y	Z
PH1Z060	208/230-1-60, 208/230-3-60, 460-3-60	368	167	14.0 (356)	20.0 (508)	16.0 (406)

Fig. 4—Unit Base Dimensions, PH1Z060

RECEIVING AND INSTALLATION

PROCEDURE 1—CHECK EQUIPMENT

A. IDENTIFY UNIT

The unit model number and serial number are stamped on the unit identification plate. Check this information against shipping papers. Verify that unit voltage and amperage listed on unit rating plate agree with power supplied for equipment.

B. INSPECT SHIPMENT

Inspect for shipping damage while unit is still on shipping pallet. If unit appears to be damaged or is torn loose from its securing points, have it examined by transportation inspectors before removal. Forward claim papers directly to transportation company. Manufacturer is not responsible for any damage incurred in transit.

Check all items against shipping list. Immediately notify the nearest Payne Air Conditioning office if any item is missing.

To prevent loss or damage, leave all parts in original packages until installation.

PROCEDURE 2—PROVIDE UNIT SUPPORT

A. SLAB MOUNT

Place the unit on a rigid, level surface, suitable to support the unit weight. A concrete pad or a suitable fiberglass mounting pad is recommended. The flat surface should extend approximately 2-in. beyond the unit casing on the 2 sides. The duct connection side and condensate drain connection sides should be flush with the edge of the flat surface.

A 6-in. wide gravel apron should be used around the flat surface to prevent airflow blockage by grass or shrubs. Do not secure the unit to the flat surface except where required by local codes.

The unit should be level to within 1/4 inch. This is necessary for the unit drain to function properly.

B. GROUND MOUNT

The unit may also be installed directly on the ground if local codes permit. Place unit on level ground prepared with gravel for condensate discharge.

PROCEDURE 3—PROVIDE CLEARANCES

The required minimum service clearances and clearances to combustibles are shown in Fig. 2-4. Adequate ventilation and outdoor coil air must be provided.

The outdoor fan pulls air through the outdoor coil and discharges it through the fan on the top cover. Be sure that the fan discharge does not recirculate to the outdoor coil. Do not locate the unit in either a corner or under an overhead obstruction. The minimum clearance under a partial overhang (such as a normal house overhang) is 48 in. above the unit top. The maximum horizontal extension of a partial overhang must not exceed 48 inches.

Do not place the unit where water, ice, or snow from an overhang or roof will damage or flood the unit. The unit may be installed on wood flooring or on Class A, B, or C roof covering materials.

⚠ CAUTION: Do not restrict outdoor coil airflow. An air restriction at either the outdoor-air inlet or the fan discharge can be harmful to compressor life.

PROCEDURE 4—PLACE UNIT

Unit can be moved with the rigging holds provided in the unit base. Refer to Table 1 for operating weights. *Use extreme caution to prevent damage when moving the unit. Unit must remain in an upright position during all moving operations.* The unit must be level within 1/4" for proper condensate drainage; the ground-level pad must be level before setting the unit in place. When a field-fabricated support is used, be sure that the support is level and that it properly supports the unit.

PROCEDURE 5—SELECT AND INSTALL DUCTWORK

The design and installation of the duct system must be in accordance with:

- the standards of the NFPA (National Fire Protection Association) for installation of nonresidence-type air conditioning and ventilating systems
- NFPA90A or residence-type, NFPA90B; and/or local codes and residence-type, NFPA 90B
- and/or local codes and ordinances

Select and size ductwork, supply-air registers and return-air grilles according to ASHRAE (American Society of Heating, Refrigeration, and Air Conditioning Engineers) recommendations.

Use the duct flanges provided on the supply- and return-air openings on the side of the unit. See Fig. 2-4 for connection sizes and locations. The 14-in. round duct collars (size 024-048 units) are shipped inside the unit attached to the indoor blower. They are field-installed and must be removed from the indoor cavity prior to start-up, even if they are not used for installation.

A. INSTALL FLANGES FOR DUCTWORK CONNECTIONS (PH1Z060 ONLY)

The PH1Z060 units are shipped with flanges which must be field-installed on the unit.

To install unit flanges:

1. Five pieces of flange are shipped on the return-air opening of the unit. Remove the flanges from the shipping position (See Fig. 5). Screws are field-supplied.
2. One piece of flange is used as it is shipped (straight). Bend the other 4 pieces at right angles.
3. Install the straight flange on the right side of the return-air opening in holes provided. (See Fig. 6). Flanges should stick out from unit to allow for connection of ductwork.

4. Install 2 hand-formed flanges onto return air opening in holes provided to form a rectangle around the return air opening.
5. Install remaining 2 hand-formed flanges around discharge air opening in holes provided.
6. Ductwork can now be attached to flanges.

When designing and installing ductwork, consider the following:

⚠ CAUTION: When connecting ductwork to units, do not drill deeper than 3/4 inch in shaded area shown in Fig. 7 or coil may be damaged.

- All units should have field-supplied filters installed in the return-air side of the unit. Recommended sizes for filters are shown in Table 1.
 - Avoid abrupt duct size increases and reductions. Abrupt change in duct size adversely affects air performance.
- IMPORTANT:** Use flexible connectors between ductwork and unit to prevent transmission of vibration. Use suitable gaskets to ensure weathertight and airtight seal. When electric heat is installed, use fire proof canvas (or similar heat resistant material) connector between ductwork and unit discharge connection. If flexible duct is used, insert a sheet metal sleeve inside duct. Heat resistant duct connector (or sheet metal sleeve) must extend 24-in. from the unit discharge connection flange into the ductwork.
- Size ductwork for cooling air quantity (cfm). The minimum air quantity for proper electric heater operation is listed in Table 2. Heater limit switches may trip at air quantities below those recommended.
 - Insulate and weatherproof all external ductwork. Insulate and cover with a vapor barrier all ductwork passing through conditioned spaces. Follow latest Sheet Metal and Air Conditioning Contractors National Association (SMACNA) and Air Conditioning Contractors Association (ACCA) minimum installation standards for residential heating and air conditioning systems.
 - Secure all ducts to building structure. Flash, weatherproof, and vibration-isolate duct openings in wall or roof according to good construction practices.

Figure 8 shows a typical duct system with PH1Z unit installed.

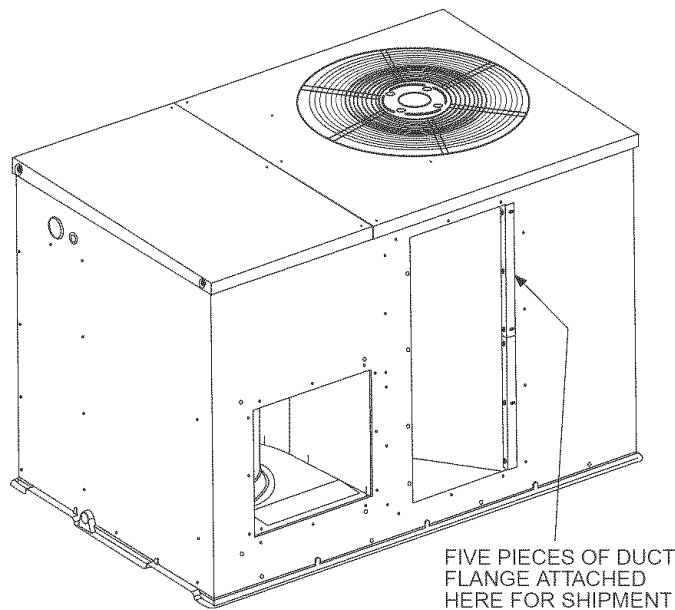

C00005

**Fig. 5—Shipping Location of Duct Flanges
(Size 060 Only)**

B. CONVERTING HORIZONTAL DISCHARGE UNITS TO DOWNFLOW (VERTICAL) DISCHARGE

⚠ WARNING: Before performing service or maintenance operations on system, turn off main power to unit and install lockout tag. Turn off accessory heater power switch if applicable. Electrical shock can cause serious injury or death.

Units are dedicated side supply products. They are not convertible to vertical air supply. A field-supplied plenum must be used to convert to vertical air discharge.

PROCEDURE 6—PROVIDE FOR CONDENSATE DISPOSAL

NOTE: Be sure that condensate-water disposal methods comply with local codes, restrictions, and practices.

Unit removes condensate through a 1 3/64-in. ID hole (using 3/4-in. OD piping or tubing) which is located at the end of the unit. See Fig. 2-4 for location of condensate connection.

Condensate water can be drained directly onto the roof in rooftop installations (where permitted) or onto a gravel apron in ground-level installations. Install a field-supplied condensate trap at end of condensate connection to ensure proper drainage. Make sure that the outlet of the trap is at least 1 in. lower than the drain-pan condensate connection to prevent the pan from overflowing. Prime the trap with water. When using a gravel apron, make sure it slopes away from the unit.

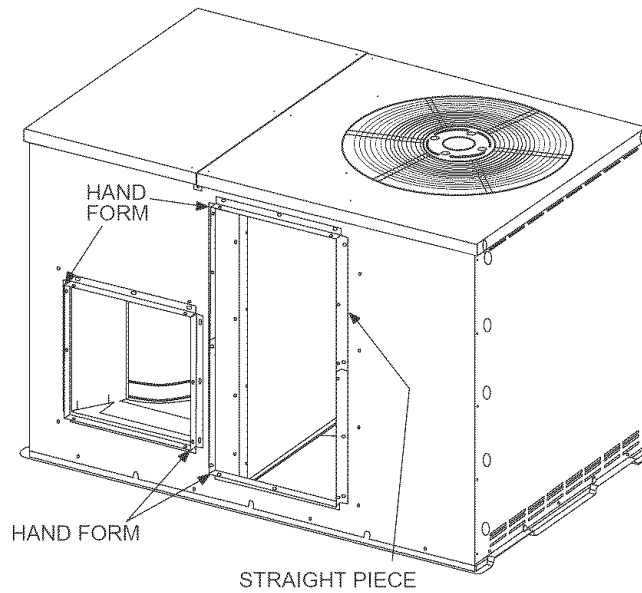

C00006

Fig. 6—Flanges Installed on PH1Z060 Units

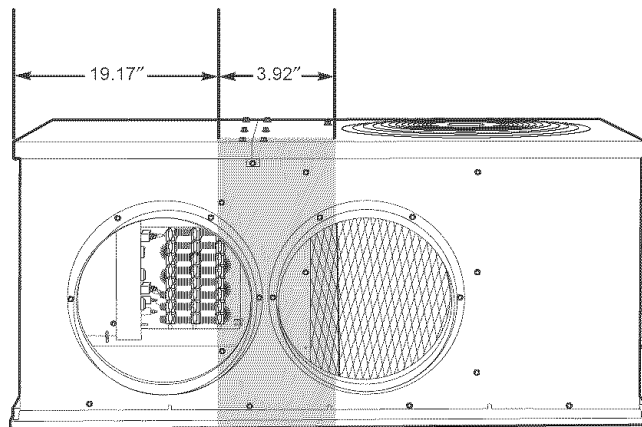

C00007

Fig. 7—Area Not to Be Drilled More Than 3/4-in.

If the installation requires draining the condensate water away from the unit, install a 2-in. trap using a 3/4-in. OD tubing or pipe. (See Fig. 9 and 10.) Make sure that the outlet of the trap is at least 1 in. lower than the unit drain-pan condensate connection to prevent the pan from overflowing. Prime the trap with water. Connect a drain tube using a minimum of 3/4-in. PVC, 3/4-in. CPVC, or 3/4-in. copper pipe (all field supplied). Do not undersize the tube. Pitch the drain tube downward at a slope of at least 1 in. for every 10 ft of horizontal run. Be sure to check the drain tube for leaks. Prime trap at the beginning of the cooling season start-up. Allowable glues for condensate trap connection are: Standard ABS, CPVC, or PVC cement.

Table 1 — Physical Data

UNIT PH1Z	024	030	036	042	048	060
OPERATING WEIGHT (lbs)	232	254	277	295	328	368
COMPRESSOR TYPE	Scroll					
REFRIGERANT Charge (lb)	R-22					
	3.7	5.8	5.9	6.6	9.1	9.7
REFRIGERANT METERING DEVICE	Acutrol™ System					
OUTDOOR COIL Rows...Fins/in. Face Area (sq ft)	Copper Tubes, Aluminum Plate Fins					
	1...17 7.9	2...17 6.7	1...17 11.1	2...17 9.3	2...17 11.1	2...17 12.7
OUTDOOR-FAN MOTOR CFM Nominal Rpm Motor Hp Diameter (in.)	Propeller					
	1800	2000	2600	2600	2600	3200
	825	1100	1100	1100	1100	1100
	1/8 20	1/4 20	1/4 20	1/4 20	1/4 20	1/2 20
INDOOR COIL	Copper Tubes, Aluminum Plate Fins					
Rows...Fins/in. Face Area (sq ft)	2...15 3.1	3...15 3.1	3...15 4.0	3...15 4.0	4...15 4.4	4...15 4.9
INDOOR FAN MOTOR Blower Motor Size (in.) Nominal Cfm Rpm Range Number of Speeds Factory Speed Setting Motor Hp	Direct Drive					
	10 x 8	10 x 8	10 x 9	10 x 9	10 x 9	10 x 10
	800	1000	1200	1400	1600	2000
	550-1000	550-1000	800-1050	800-1050	1000-1100	950-1100
	3	3	3	3	2	3
	Low 1/4	Med 1/4	Low 1/2	Med 1/2	Low 3/4	Low 1
CONNECTING DUCT SIZES Supply Air (in.) Return Air (in.)	Round					Square
	14 14					13.9 x 13.9 13.9 x 27.8
FIELD-SUPPLIED RETURN-AIR FILTER† Throwaway (in.)	24 x 24	24 x 24	24 x 24	24 x 24	24 x 30	24 x 30

* 460-v motors are 2-speed or 3-speed.

†Required filter sizes shown are based on the ARI (Air Conditioning and Refrigeration Institute) rated airflow at a velocity of 300 ft/min for throwaway type or 450 ft/min for high capacity type. Recommended filters are 1-in. thick.

PROCEDURE 7—INSTALL ELECTRICAL CONNECTIONS

⚠ WARNING: The unit cabinet must have an uninterrupted, unbroken electrical ground to minimize the possibility of personal injury if an electrical fault should occur. This ground may consist of an electrical wire connected to the unit ground in the control compartment, or conduit approved for electrical ground when installed in accordance with NEC (National Electrical Code), ANSI (American National Standards Institute)/NFPA (latest edition) (in Canada, Canadian Electrical Code CSA C22.1) and local electrical codes. Failure to adhere to this warning could result in serious injury or death.

⚠ CAUTION: Failure to follow these precautions could result in damage to the unit being installed:

1. Make all electrical connections in accordance with NEC ANSI/NFPA (latest edition) and local electrical codes governing such wiring. In Canada, all electrical connections must be in accordance with CSA standard C22.1 Canadian Electrical Code Part 1 and applicable local codes. Refer to unit wiring diagram.
2. Use only *copper* conductor for connections between field-supplied electrical disconnect switch and unit. DO NOT USE ALUMINUM WIRE.
3. Be sure that high-voltage power to unit is within operating voltage range indicated on unit rating plate.
4. Insulate low-voltage wires for highest voltage contained within conduit when low-voltage control wires are run in same conduit as high-voltage wires.
5. Do not damage internal components when drilling through any panel to mount electrical hardware, conduit, etc. On 3-phase units, ensure phases are balanced within 2 percent. Consult local power company for correction of improper voltage and/or phase imbalance.

A. HIGH-VOLTAGE CONNECTIONS

The unit must have a separate electrical service with a field-supplied, waterproof disconnect switch mounted at, or within sight from the unit. Refer to the unit rating plate for maximum fuse/circuit breaker size and minimum circuit amps (ampacity) for wire sizing. See Table 3 for electrical data. The field-supplied disconnect may be mounted on the unit over the high-voltage inlet hole. See Fig. 2-4.

⚠ CAUTION: Operation of unit on improper line voltage constitutes abuse and may cause unit damage that could affect warranty.

B. ROUTING POWER LEADS INTO UNIT

Use only copper wire between disconnect and unit. The high-voltage leads should be in a conduit until they enter the unit; conduit termination at the unit must be watertight. Run the high-voltage leads through the hole on the control box side of the unit (see Fig. 11 for location). When the leads are inside the unit, run leads to the control box (Fig. 12). For single-phase units, connect leads to the black and yellow wires; for 3-phase units, connect the leads to the black, yellow, and blue wires (see Fig. 13).

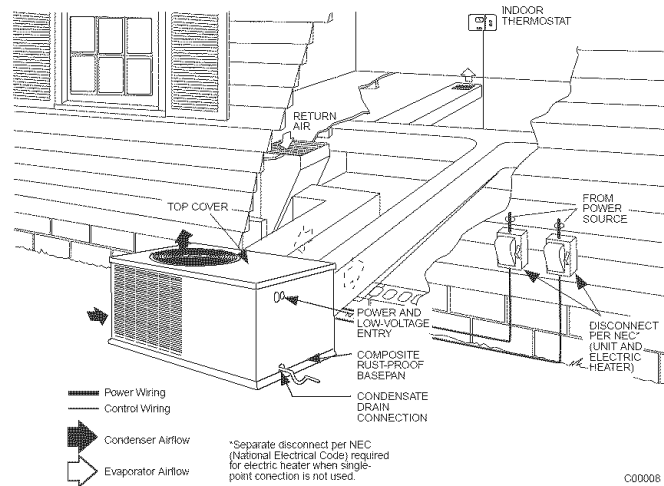

C00008

C00008

Table 2—Minimum Airflow for Safe Electric Heater Operation (CFM)

SIZE					
024	030	036	042	048	060
600	750	900	1050	1200	1500

Fig. 8—Typical installation

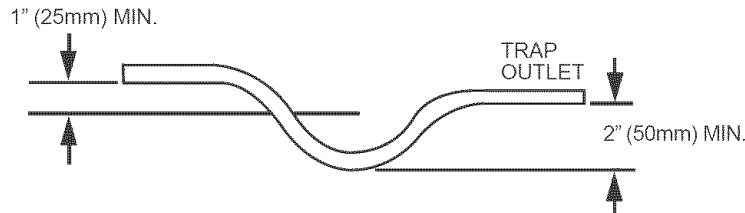

C99013

Fig. 9—Condensate Trap (Using Tubing)

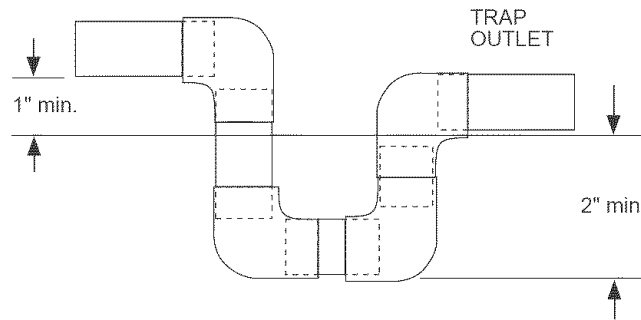

C00009

Fig. 10—PVC Condensate Trap

C. CONNECTING GROUND LEAD TO UNIT GROUND

Refer to Fig. 12 and 13. Connect the ground lead to the chassis using the unit ground lug in the control box.

D. ROUTING CONTROL POWER WIRES

Form a drip-loop with the thermostat leads before routing them into the unit. Route the thermostat leads through grommeted hole provided in unit into unit control box (See Fig. 11). Connect thermostat leads and unit power leads as shown in Fig. 13 & 14.

Route thermostat wires through grommet providing a drip-loop at the panel. Connect low-voltage leads to the thermostat as shown in Fig. 14.

The unit transformer supplies 24-v power for complete system including accessory electrical heater. Transformer is factory wired for 230-v operation. If supply voltage is 208 v, rewire transformer primary as described in the Special Procedures for 208-v Operation section below.

E. ACCESSORY ELECTRIC HEAT WIRING

Refer to accessory electric heat installation instructions for information on installing accessory electric heat. Accessory electric heat wiring is shown in Fig. 15A & 15B.

F. SPECIAL PROCEDURES FOR 208-V OPERATION

⚠ WARNING: Make sure that the power supply to the unit is switched OFF and install lockout tag before making any wiring changes. Electrical shock can cause serious injury or death.

1. Remove wrenut from connection of ORG wire to BLK wire. Disconnect the ORG transformer-primary lead from the BLK wire. Save wrenut. See unit wiring label.
2. Remove the wrenut from the terminal on the end of the RED transformer-primary lead.
3. Save the wrenut.
4. Connect the RED lead to the BLK wire from which the ORG lead was disconnected. Insulate with wrenut from Step 1.
5. Using the wrenut removed from the RED lead, insulate the loose terminal on the ORG lead.
6. Wrap the wrenuts with electrical tape so that the metal terminals cannot be seen.

Indoor blower-motor speeds may need to be changed for 208-v operation. Refer to Indoor Airflow and Airflow Adjustments section. (See Table of Contents for page number.)

PRE-START-UP

⚠ WARNING: Failure to observe the following warnings could result in serious injury or death:

1. Follow recognized safety practices and wear protective goggles when checking or servicing refrigerant system.
2. Do not operate compressor or provide any electric power to unit unless compressor terminal cover is in place and secured.
3. Do not remove compressor terminal cover until all electrical sources are disconnected and lockout tag is installed.
4. Relieve all pressure from both high- and low-pressure sides of the system before touching or disturbing anything inside terminal box if refrigerant leak is suspected around compressor terminals. Use accepted methods to recover refrigerant.
5. Never attempt to repair soldered connection while refrigerant system is under pressure.
6. Do not use torch to remove any component. System contains oil and refrigerant under pressure. To remove a component, wear protective goggles and proceed as follows:
 - a. Shut off electrical power to unit and install lockout tag.
 - b. Relieve all refrigerant from system using both high- and low-pressure ports. Use accepted methods to recover refrigerant.
 - c. Cut component connecting tubing with tubing cutter and remove component from unit.
 - d. Carefully unsweat remaining tubing stubs when necessary. Oil can ignite when exposed to torch flame.

Use the Start-Up Checklist supplied at the end of this book and proceed as follows to inspect and prepare the unit for initial start-up:

1. Remove all access panels.

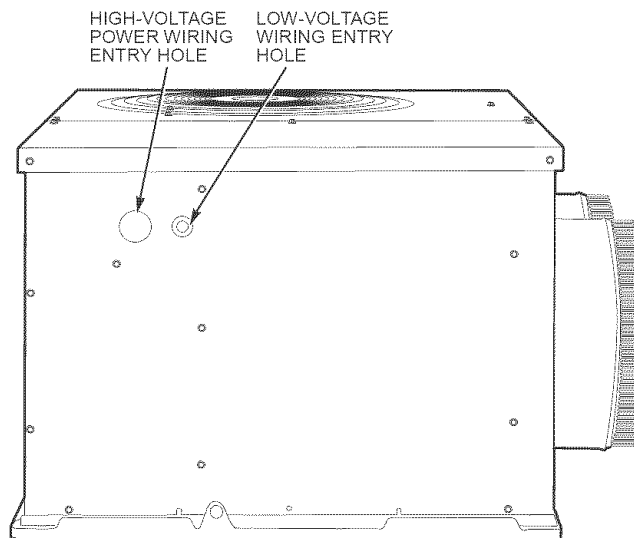
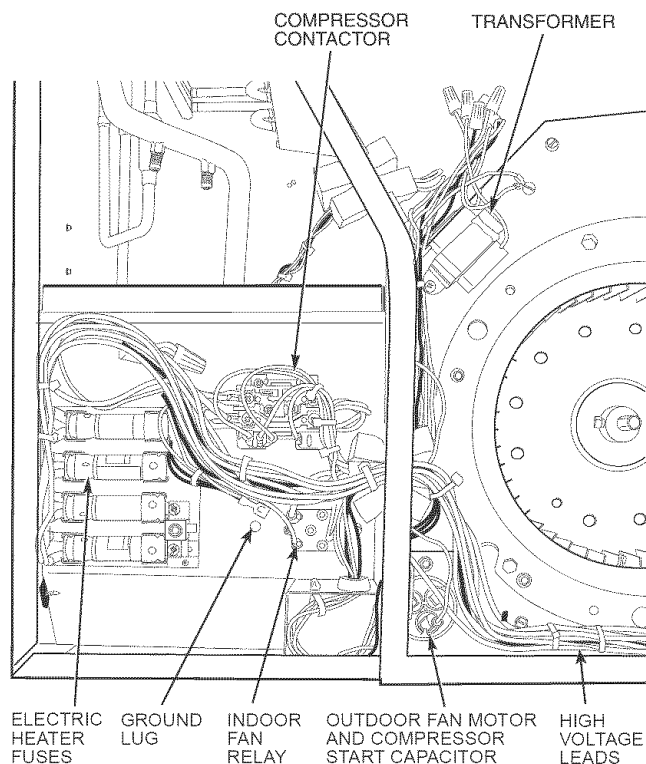

Fig. 11—Unit Electrical Connection

C00010

2. Read and follow instructions on all DANGER, WARNING, CAUTION, and INFORMATION labels attached to, or shipped with, unit. Make the following inspections:
 - a. Inspect for shipping and handling damages such as broken lines, loose parts, disconnected wires, etc.
 - b. Inspect for oil at all refrigerant tubing connections and on unit base. Detecting oil generally indicates a refrigerant leak. Leak-test all refrigerant tubing connections using electronic leak detector, or liquid-soap solution. If a refrigerant leak is detected, see following Check for Refrigerant Leaks section.
 - c. Inspect all field- and factory-wiring connections. Be sure that connections are completed and tight. Ensure wires do not contact refrigerant tubing or sheet metal edges.



C00011

Fig. 12—Control Box Wiring

- d. Inspect coil fins. If damaged during shipping and handling, carefully straighten fins with a fin comb.
3. Verify the following conditions:
 - a. Make sure that outdoor-fan blade is correctly positioned in fan orifice. Top edge of blade should be 3.125 in. down from outdoor coil outlet grille (size 024-048, See Fig. 21) or hub should be 0.708-in. away from motor end bell (size 060, See Fig. 22). See Outdoor Fan Adjustment section.
 - b. Make sure that air filter is in place.
 - c. Make sure that condensate drain trap is filled with water to ensure proper drainage.
 - d. Make sure that all tools and miscellaneous loose parts have been removed.

START-UP

Use the Start-Up Checklist supplied at the end of this book and proceed as follows:

PROCEDURE 1—CHECK FOR REFRIGERANT LEAKS

A. LOCATE AND REPAIR REFRIGERANT LEAKS AND CHARGE THE UNIT AS FOLLOWS:

1. Using both high- and low-pressure ports, locate leaks and reclaim remaining refrigerant to relieve system pressure.
2. Repair leak following accepted practices.

NOTE: Install a liquid-line filter drier whenever the system has been opened for repair.

PROCEDURE 2—START-UP COOLING SECTION AND MAKE ADJUSTMENTS

⚠ CAUTION: Complete the required procedures given in the Pre-Start-Up section this page before starting the unit. Do not jumper any safety devices when operating the unit. Do not operate the compressor when the outdoor temperature is below 40 F. Do not rapid-cycle the compressor. Allow 5 minutes between “on” cycles to prevent compressor damage.

A. CHECKING COOLING CONTROL OPERATION

Start and check the unit for proper cooling control operation as follows:

1. Place room thermostat SYSTEM switch in OFF position. Observe that blower motor starts when FAN switch is placed in ON position and shuts down within 30 seconds when FAN switch is placed in AUTO position.
2. Place SYSTEM switch in COOL position and FAN switch in AUTO position. Set cooling control below room temperature. Observe that compressor, outdoor fan, and indoor blower motors start and that reversing valve shifts. Observe that cooling cycle shuts down when control setting is satisfied. Reversing valve (RV) remains energized.
3. Place system switch in HEAT position. Observe that compressor, indoor fan and outdoor fan energize (Reversing Valve is deenergized in heat pump heating mode). Set control above room temperature. Observe that heating cycle shuts down when control setting is satisfied.

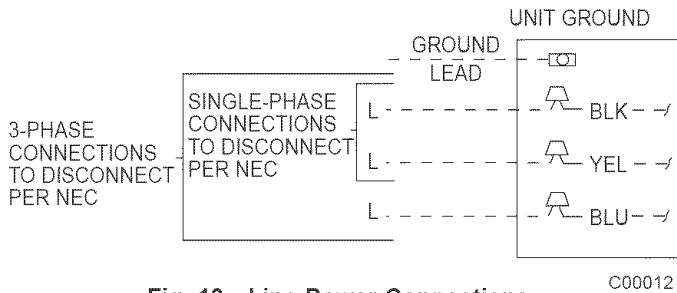

Fig. 13—Line Power Connections

C00012

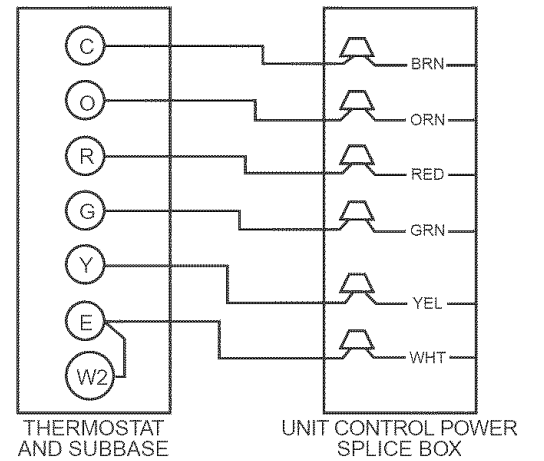

Fig. 14—Control Connections

C99056

- When using an automatic changeover room thermostat, place both SYSTEM and FAN switches in AUTO. positions. Observe that unit operates in Cooling mode when temperature control is set to “call for cooling” (below room temperature), and unit operates in Heating mode when temperature control is set to “call for heating” (above room temperature).

B. COMPRESSOR ROTATION

On 3-Phase units it is important to be certain compressor is rotating in the proper direction. To determine whether or not compressor is rotating in the proper direction:

- Connect service gages to suction and discharge pressure fittings.
- Energize the compressor.
- The suction pressure should drop and the discharge pressure should rise, as is normal on any start-up.

If the suction pressure does not drop and the discharge pressure does not rise to normal levels:

- Turn off power to the unit and tag disconnect.
- Reverse any two of the unit power leads.
- Turn on power to the unit.

The suction and discharge pressure levels should now move to their normal start-up levels.

NOTE: When the compressor is rotation in the wrong direction, the unit makes an elevated level of noise and does not provide cooling.

PROCEDURE 3—REFRIGERANT CHARGE

Refrigerant Charge — Amount of refrigerant charge is listed on unit nameplate and in Table 1. Refer to Payne Refrigerant Service Techniques Manual, Refrigerants section. Unit panels must be in place when unit is operating during charging procedure. Unit must operate a minimum of 15 minutes before checking charge.

A. NO CHARGE

Refer to Payne Refrigerant Service Techniques. Use standard evacuating techniques. After evacuating system, weigh in the specified amount of refrigerant (refer to Table 1).

B. LOW CHARGE COOLING

Using cooling charging chart (see Fig. 16–21), Vary refrigerant until conditions of the chart are met. Note that charging chart is different from those normally used. Charts are based on charging the units to the correct superheat for the various operating conditions. An accurate pressure gage and temperature-sensing device is required. Connect the pressure gage to the service port on the suction line. Connect temperature sensing device to the suction line near the compressor and insulate it so that outdoor ambient temperature does not affect reading.

C. TO USE THE COOLING CHARGING CHART

This method is to be used in cooling mode only. Take the outdoor ambient temperature and read the suction pressure gauge. Refer to charts to determine what the suction temperature should be. If suction temperature is high, add refrigerant. If suction temperature is low, carefully recover some of the charge. Recheck the suction pressure as charge is adjusted.

Example: (See Fig. 16)

Outdoor Temperature — 85°F

Suction Pressure — 74 psig

Suction Temperature should be — 60°F

Note—Suction Temperature may vary +/- 5°F.

D. HEATING MODE CHARGE

Do not attempt to adjust charge by cooling methods while in heat pump heating mode. Recover refrigerant and weigh in according to unit data plate refrigerant data.

PROCEDURE 4—INDOOR AIRFLOW AND AIRFLOW ADJUSTMENTS

NOTE: For cooling operation, the recommended airflow is 350 to 450 cfm per each 12,000 Btuh of rated cooling capacity.

Table 4 shows dry coil air delivery for horizontal discharge units. Tables 5-7 show pressure drops.

NOTE: Be sure that all supply- and return-air grilles are open, free from obstructions, and adjusted properly.

⚠ WARNING: Disconnect electrical power to the unit and install lockout tag before changing blower speed. Electrical shock can cause serious injury or death.

Airflow can be changed by changing the lead connections of the blower motor.

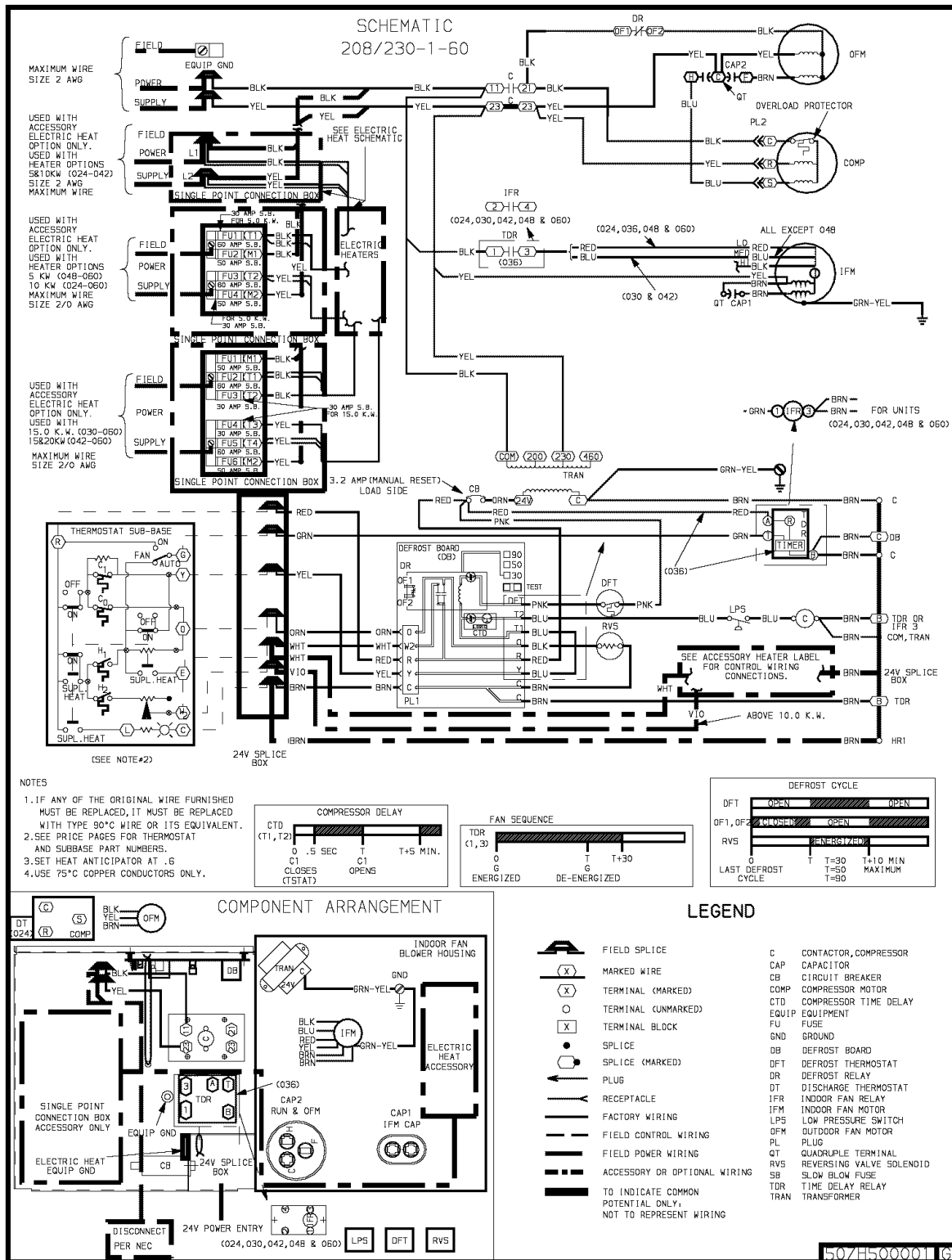

Fig. 15A—Typical Unit Electrical Diagram (208/230-1-60)

Units PH1Z024, 036, 048, and 060 blower motors are factory wired for low speed operation. Units PH1Z030 and 042 are factory wired for medium speed operation.

A. FOR 208/230-V (See Page 18)

The motor leads are color-coded as follows:

To change the speed of the indoor fan motor (IFM), remove the fan motor speed leg lead from the indoor fan relay (IFR) with units 024, 030, 042, 048 & 060 or the time delay relay (TDR) on 036 size and replace with lead for desired blower motor speed. *Insulate the removed lead to avoid contact with chassis parts.*

B. FOR 460-V MOTORS (See Page 18)

The motor leads are color coded as follows:

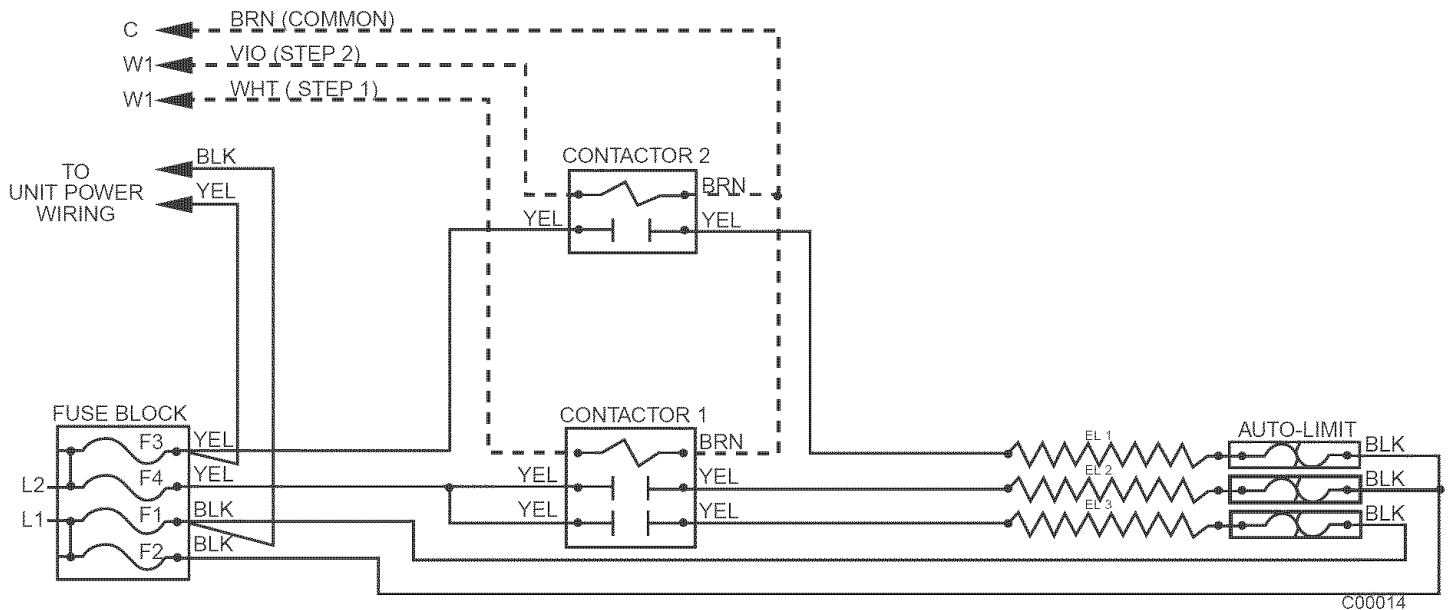

Fig. 15B—Accessory Electric Heater Wiring

To change the speed of the indoor fan motor (IFM) from low speed to high speed, remove the red lead from the indoor-fan relay (IFR). ON 2-Speed Motors: Insulate the red lead to avoid contact with any chassis parts. Separate the black lead from the purple lead. Connect the black lead to the IFR. Insulate the purple lead to avoid contact with any chassis parts. ON 3-Speed Motors: remove the fan motor speed leg lead from the indoor (indoor) fan relay (IFR) and replace with lead for desired blower motor speed.

PROCEDURE 5—UNIT CONTROLS

All compressors have the following internal-protection controls.

A. HIGH-PRESSURE RELIEF VALVE

This valve opens when the pressure differential between the low and high side becomes excessive (024 size has temperature relief only).

B. LOSS OF CHARGE SWITCH

Located on the outdoor liquid line is a low-pressure switch which functions as a loss-of-charge switch. This switch contains a Schrader core depressor. This switch opens at 7 psig and closes at 22 psig. No adjustment is necessary.

C. COMPRESSOR OVERLOAD

This overload interrupts power to the compressor when either the current or internal temperature become excessive, and automatically resets when the internal temperature drops to a safe level. This overload may require up to 60 minutes (or longer) to reset; therefore, if the internal overload is suspected of being open, disconnect the electrical power to the unit and check the circuit through the overload with an ohmmeter or continuity tester.

PROCEDURE 6—SEQUENCE OF OPERATION

A. FAN OPERATION

The FAN switch on the thermostat controls indoor fan operation. When the FAN switch is placed in the ON position, the IFR (indoor-fan relay) is energized through the G terminal on the thermostat. The normally-open contacts close, which then provide power to the indoor (evaporator) fan motor (IFM). The IFM will run continuously when the FAN switch is set to ON.

When the FAN switch is set to AUTO, the thermostat deenergizes the IFR (provided there is not a call for cooling). The contacts open and the IFM is deenergized. The IFM will be energized only when there is a call for cooling, in heat pump heating mode or if the unit is equipped with accessory electric heat, the indoor-fan motor will also run while the accessory electric heat is energized.

NOTE: Some units are equipped with a time-delay relay. On these units, the indoor fan remains on for 30 seconds after G or Y is deenergized.

B. COOLING

With the thermostat subbase in the cooling position, the thermostat makes circuit R-O. This energizes the reversing valve solenoid (RVS) and places the unit in standby condition for cooling.

NOTE: The defrost control board has a 5 minute compressor anti-short cycle time delay built in between compressor starts.

On a call for cooling, the compressor contactor (C) and the IFR are energized through the Y and G terminals of the thermostat. Energizing the compressor contactor supplies power to the compressor and the outdoor (condenser) fan motor (OFM). Energizing the IFR provides power to the IFM.

When the need for cooling has been satisfied, the OFM, compressor, and IFM (FAN on AUTO) are deenergized. If the unit is equipped with a 30-second delay (036 size only), the indoor fan will remain energized for 30 seconds after the compressor is deenergized. The reversing valve solenoid remains energized.

C. HEAT PUMP HEATING

On a call for heat, thermostat makes circuits R-Y and R-G. When compressor time delay (5-minute \pm 2 minutes) is completed, a circuit is made to C, starting COMP and OFM. Circuit R-G also energizes IFR and starts IFM after 1-second delay.

Table 3—Electrical Data—PH1Z

UNIT PH1Z SIZE (-SERIES, IF USED)	V-PH-HZ	VOLTAGE RANGE		COMPRESSOR		OFM FLA	IFM FLA	ELECTRIC HEAT		SINGLE POINT POWER SUPPLY		
		MIN	MAX	RLA	LRA			Nominal KW*	FLA	MCA	FUSE OR CKT BKR	MOCP
024-311	208/230-1-60	187	254	11.4	56.0	0.9	2.4	-/-	-/-	17.6/17.6	25/25	-
								3.8/5.0	18.3/20.8	40.4/43.6	45/45	-
								5.6/7.5	26.9/31.3	51.2/56.7	60/60	-
024-321	208/230-1-60	187	254	12.1	54.0	0.9	2.4	-/-	-/-	18.4/18.4	25/25	-
								3.8/5.0	18.3/20.8	41.3/44.4	45/45	-
								5.6/7.5	26.9/31.3	52.1/57.6	60/60	-
030	208/230-1-60	187	254	14.4	73.0	1.5	2.4	-/-	-/-	21.9/21.9	30/30	-
								3.8/5.0	18.3/20.8	44.8/47.9	45/50	-
								5.6/7.5	26.9/31.3	55.5/61.0	60/-	-70
036	208/230-3-60	187	254	10.0	63.0	1.5	5.8	-/-	-/-	16.8	20	-
								3.8/5.0	10.4/12.0	29.9/31.8	35/35	-
								7.5/10.0	20.8/24.1	42.8/46.9	45/50	-
042	208/230-1-60	187	254	17.7	93.0	1.5	2.8	-/-	-/-	26.4/26.4	35/35	-
								3.8/5.0	18.1/20.8	49.3/52.4	50/60	-
								5.6/7.5	26.9/31.3	60.1/65.6	-	70/70
048	208/230-3-60	187	254	11.4	77.0	1.5	2.8	-/-	-/-	18.6/18.6	25/25	-
								3.8/5.0	10.4/12.0	31.7/33.6	35/35	-
								7.5/10.0	20.8/24.1	44.6/48.7	45/50	-
060	460-3-60	414	508	5.7	39.0	0.8	2.0	-	-	9.9	15	-
								5	6.0	17.4	20	-
								10	12.0	24.9	25	-
042	208/230-1-60	187	254	22.0	103.0	1.5	2.8	-/-	-/-	31.8/31.8	40/40	-
								3.8/5.0	18.3/20.8	54.7/57.8	60/60	-
								5.6/7.5	26.9/31.3	65.4/70.9	-	70/80
048	208/230-3-60	187	254	13.9	88.0	1.5	2.8	-/-	-/-	21.7/21.7	30/30	-
								3.8/5.0	10.5/12.0	34.8/36.7	35/40	-
								7.5/10.0	20.8/24.1	47.7/51.8	50/50	-
060	460-3-60	414	508	6.8	44.0	0.8	2.0	-	-	11.3	15	-
								5	6.0	18.8	20	-
								10	12.0	26.3	30	-
048	208/230-1-60	187	254	21.8	124.0	1.5	4.2	-/-	-/-	33.0/33.0	40/40	-
								3.8/5.0	18.3/20.8	55.8/59.0	60/60	-
								5.6/7.5	26.9/31.3	66.6/72.1	-	70/80
060	208/230-3-60	187	254	12.8	93.0	1.5	4.2	-/-	-/-	21.7/21.7	25/25	-
								3.8/5.0	10.5/12.0	34.8/36.7	35/40	-
								7.5/10.0	20.8/24.1	47.7/51.8	50/60	-
060	460-3-60	414	508	6.4	46.5	0.8	4.2	-	-	10.9	15	-
								5	6.0	18.4	20	-
								10	12.0	25.9	30	-
060	230-1-60	187	254	27.7	170.0	3.1	6.2	-	-	43.9/43.9	60/60	-
								3.8/5	18.3/20.8	66.8/69.9	-	70/70
								5.6/7.5	26.9/31.3	77.6/83.1	-	80/90
060	208/230-3-60	187	254	15.9	124.0	3.1	6.2	-/-	-/-	29.2/29.2	35/35	-
								3.8/5.0	10.5/12.0	42.3/44.2	45/45	-
								7.5/10.0	20.8/24.1	55.2/59.3	60/60	-
060	460-3-60	414	508	8.0	59.6	1.5	3.2	-	-	14.7	20	-
								5	6.0	22.2	25	-
								10	12.0	29.7	30	-
060	460-3-60	414	508	8.0	59.6	1.5	3.2	15	18.0	37.2	40	-
								19.9	23.9	44.6	45	-

(See legend following Electrical Data charts)

Should room temperature continue to fall, circuit R-W is made through second-stage thermostat bulb. If optional electric heat package is used, a relay is energized, bringing on first bank of supplemental electric heat. When thermostat is satisfied, contacts open, deenergizing contactor and relay; motors and heaters deenergize. The IFM may be controlled by a time-delay relay that keeps the fan on for 30 seconds.

LEGEND

- FLA — Full Load Amps
- LRA — Locked Rotor Amps
- MCA — Minimum Circuit Amps
- MOCP — Maximum Overcurrent Protection
- RLA — Rated Load Amps
- CKT BKR — Circuit Breaker



NOTES:

1. In compliance with NEC (National Electrical Code) requirements for multimotor and combination load equipment (refer to NEC Articles 430 and 440), the overcurrent protective device for the unit shall be Power Supply fuse. Canadian units may be fuse or circuit breaker.
2. Minimum wire size is based on 60 C copper wire. If other than 60 C wire is used, or if length exceeds wire length in table, determine size from NEC.
3. Unbalanced 3-Phase Supply Voltage
Never operate a motor where a phase imbalance in supply voltage is greater than 2%. Use the following formula to determine the percentage of voltage imbalance.

% Voltage imbalance

$$= 100 \times \frac{\text{max voltage deviation from average voltage}}{\text{average voltage}}$$

EXAMPLE: Supply voltage is 460-3-60.

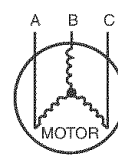

- AB = 452 v
- BC = 464 v
- AC = 455 v

$$\begin{aligned} \text{Average Voltage} &= \frac{452 + 464 + 455}{3} \\ &= \frac{1371}{3} \\ &= 457 \end{aligned}$$

Determine maximum deviation from average voltage.

- (AB) 457 452 = 5 v
- (BC) 464 457 = 7 v
- (AC) 457 455 = 2 v

Maximum deviation is 7 v.

Determine percent of voltage imbalance.

$$\begin{aligned} \% \text{ Voltage Imbalance} &= 100 \times \frac{7}{457} \\ &= 1.53\% \end{aligned}$$

This amount of phase imbalance is satisfactory as it is below the maximum allowable 2%.

IMPORTANT: If the supply voltage phase imbalance is more than 2%, contact your local electric utility company immediately.

C99024

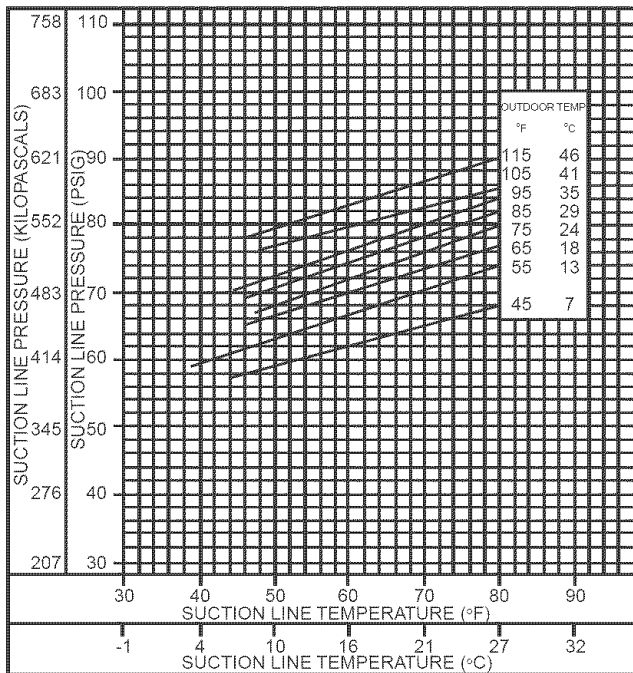

Fig. 16—Cooling Charging Chart, PH1Z024 Units

C00162

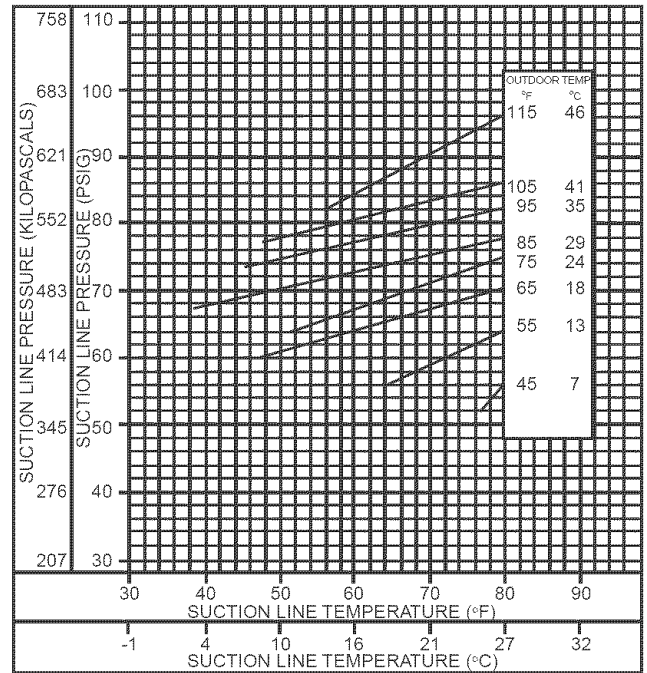

Fig. 17—Cooling Charging Chart, PH1Z030

C00163

D. DEFROST

Defrost board (DB) is a time and temperature control, which includes a field-selectable time period between checks for defrost (30, 50 and 90 minutes). The time period is factory-set at 30 minutes and should only be adjusted by a trained service person. Electronic timer and defrost cycle start only when contactor is energized and defrost thermostat (DFT) is closed.

Defrost mode is identical to Cooling mode. The outdoor fan motor stops because of "OF1" and "OF2" contacts opening on the defrost board, a bank of optional electric heat turns on to warm air supplying the conditioned space.

E. ELECTRIC RESISTANCE HEATING

If accessory electric heaters are installed, on a call for "Emergency Heat" the thermostat energizes W which energises the heater relay and in turn energizes the electric heaters. The IFR is energized which starts the indoor-fan motor. If the heaters are staged, W2 is energized when the second stage of heating is required. When the need for heating is satisfied, the heater and IFM are deenergized.

MAINTENANCE

To ensure continuing high performance, and to reduce the possibility of premature equipment failure, periodic maintenance must be performed on this equipment. This cooling unit should be inspected at least once each year by a qualified service person. To troubleshoot cooling of units, refer to Troubleshooting chart in back of book.

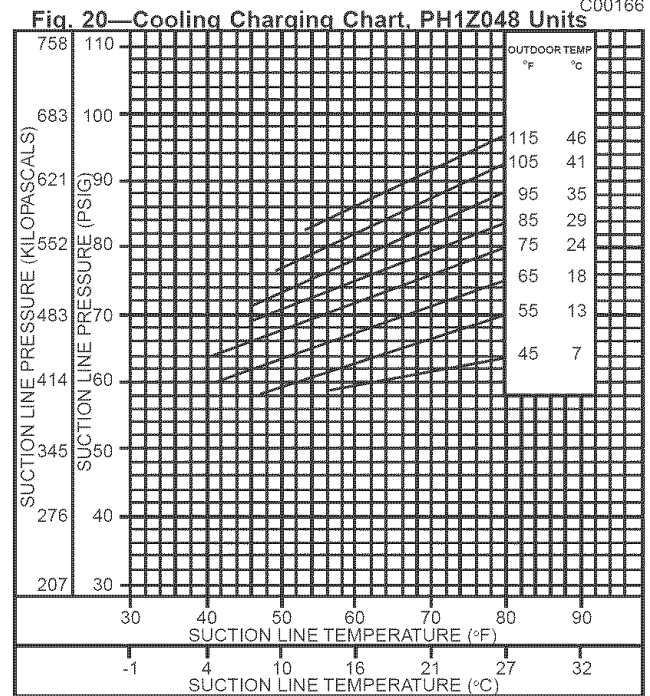
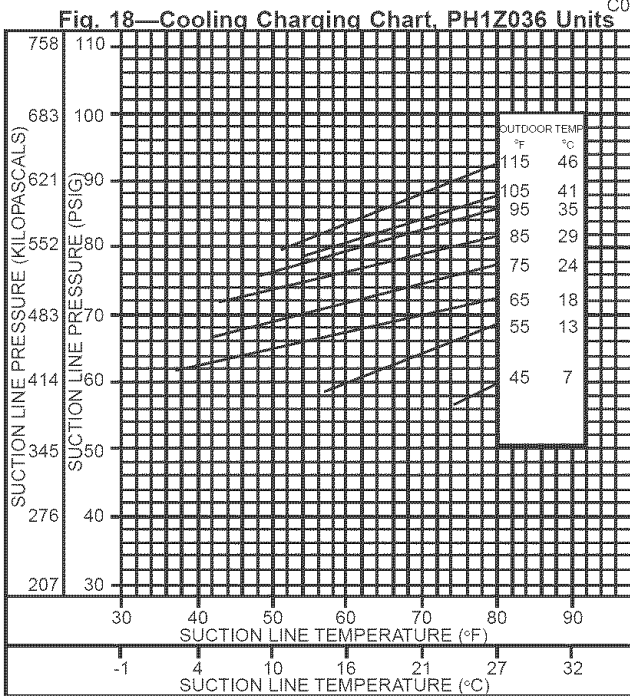
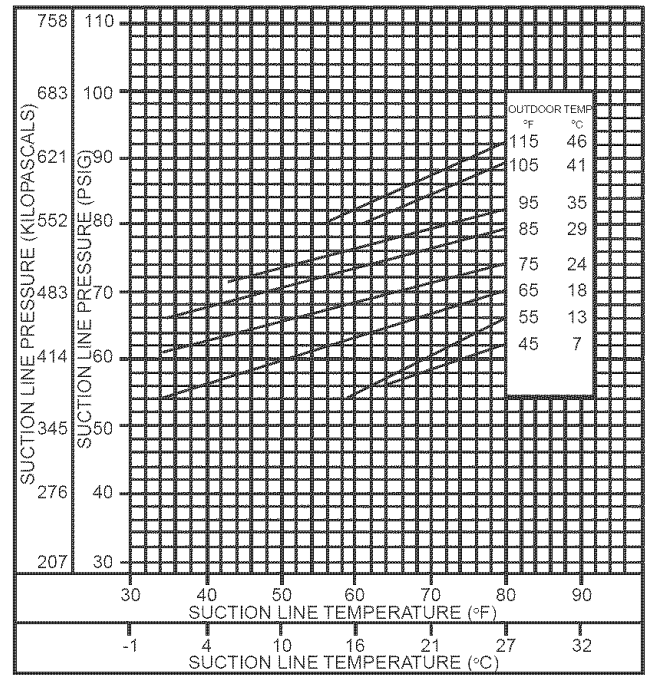
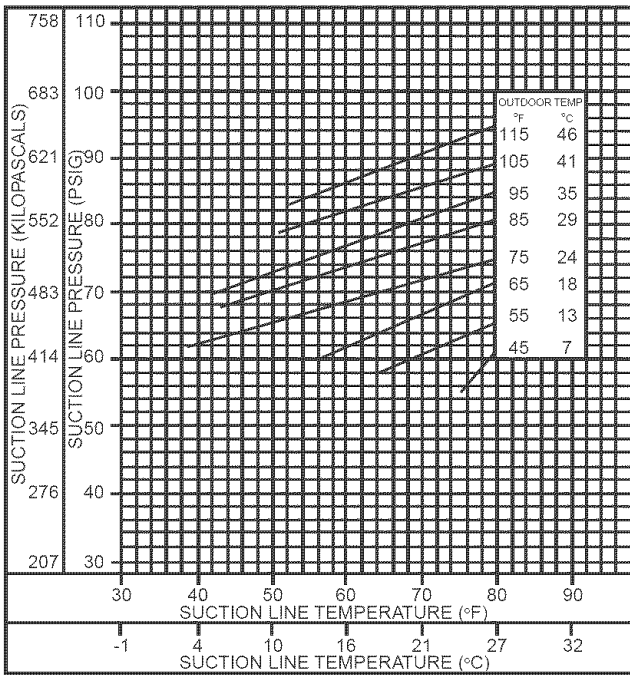

FOR 208/230-V

The motor leads are color-coded as follows:

3-SPEED	2-SPEED
black = high speed	black = high speed
blue = medium speed	-
red = low speed	red = low speed

FOR 460-V MOTORS

The motor leads are color coded as follows:

3-SPEED (060 ONLY)	2-SPEED
black = high speed	black = to purple
-	yellow = line
orange = medium speed	purple = to black
blue = low speed	red = line

NOTE TO EQUIPMENT OWNER: Consult your local dealer about the availability of a maintenance contract.

⚠ WARNING: The ability to properly perform maintenance on this equipment requires certain expertise, mechanical skills, tools and equipment. If you do not possess these, do not attempt to perform any maintenance on this equipment, other than those procedures recommended in the User's Manual. FAILURE TO HEED THIS WARNING COULD RESULT IN SERIOUS INJURY, DEATH OR DAMAGE TO THIS EQUIPMENT.

The minimum maintenance requirements for this equipment are as follows:

1. Inspect air filter(s) each month. Clean or replace when necessary.
2. Inspect indoor coil, outdoor coil, drain pan, and condensate drain each cooling and heating season for cleanliness. Clean when necessary.
3. Inspect blower motor and wheel for cleanliness each cooling and heating season. Clean when necessary. For first heating season, inspect blower wheel bimonthly to determine proper cleaning frequency.
4. Check electrical connections for tightness and controls for proper operation each cooling season. Service when necessary.
5. Check the drain channel in the top cover periodically for blockage (leaves, insects). Clean as needed.

⚠ WARNING: Failure to follow these warnings could result in serious injury or death:

1. Turn off electrical power to the unit and install lockout tag before performing any maintenance or service on the unit.
2. Use extreme caution when removing panels and parts. As with any mechanical equipment, personal injury can result from sharp edges, etc.
3. Never place anything combustible either on, or in contact with, the unit.

PROCEDURE 1—AIR FILTER

NOTE: Never operate the unit without a suitable air filter in the return-air duct system. Always replace the filter with the same size as originally installed. See Table 1 for recommended filter sizes

Inspect air filter(s) at least once each month and replace (throwaway-type) or clean (cleanable-type) at least twice during each cooling season or whenever the filters become clogged with dust and lint.

Replace filters with the same dimensional size and type as originally provided, when necessary.

PROCEDURE 2—UNIT TOP REMOVAL (OUTDOOR-COIL SIDE)

NOTE: When performing maintenance or service procedures that require removal of the unit top, be sure to perform all of the routine maintenance procedures that require top removal, including coil inspection and cleaning, and condensate drain pan inspection and cleaning.

⚠ WARNING: Disconnect and tag electrical power to the unit before removing top. Failure to adhere to this warning could cause serious injury or death.

Only qualified service personnel should perform maintenance and service procedures that require unit top removal.

Refer to the following top removal procedures:

1. Remove 7 screws on unit top cover surface. (Save all screws.)
2. Remove 2 screws on unit top cover flange. (Save all screws.)
3. Lift top from unit carefully. Set top on edge and make sure that top is supported by unit side that is opposite duct (or plenum) side.
4. Carefully replace and secure unit top to unit, using screws removed in Steps 1 and 2, when maintenance and/or service procedures are completed.

PROCEDURE 3—INDOOR BLOWER AND MOTOR

For longer life, operating economy, and continuing efficiency, clean accumulated dirt and grease from the blower wheel and motor annually.

⚠ WARNING: Disconnect and tag electrical power to the unit before cleaning the blower wheel. Failure to adhere to this warning could cause serious injury or death.

To clean the blower wheel:

1. Access the blower assembly as follows:
 - a. Remove top access panel.
 - b. Remove 3 screws that hold blower orifice ring to blower housing. Save screws.
 - c. Loosen setscrew(s) which secure wheel to motor shaft.
2. Remove and clean blower wheel as follows:
 - a. Lift wheel from housing. When handling and/or cleaning blower wheel, be sure not to disturb balance weights (clips) on blower wheel vanes.
 - b. Remove caked-on dirt from wheel and housing with a brush. Remove lint and/or dirt accumulations from wheel and housing with vacuum cleaner, using a soft brush attachment. Remove grease and oil with a mild solvent.

**Table 4—Dry Coil Air Delivery* Horizontal Discharge
(Deduct 10 percent for 208 Volt Operation)**

230 AND 460 VOLT											
Unit	Motor Speed	Watts/CFM	External Static Pressure (in. wg)								
			0.1	0.2	0.3	0.4	0.5	0.6	0.7	0.8	0.9
024	Low	Watts	288	285	282	279	274	268	261	-	-
		Cfm	875	820	802	734	668	582	478	-	-
	Med	Watts	390	383	378	369	360	350	340	-	-
		Cfm	1131	1090	1038	978	917	830	721	-	-
	High	Watts	528	520	510	495	480	460	450	-	-
		Cfm	1391	1338	1285	1200	1115	1018	920	-	-
030	Low	Watts	288	285	282	279	274	268	261	-	-
		Cfm	875	820	802	734	668	582	478	-	-
	Med	Watts	390	383	378	369	360	350	340	-	-
		Cfm	1131	1090	1038	978	917	830	721	-	-
	High	Watts	528	520	510	495	480	460	450	-	-
		Cfm	1891	1338	1285	1200	1115	1018	920	-	-
036	Low	Watts	450	435	420	400	380	335	326	311	-
		Cfm	1231	1218	1204	1120	1008	950	863	751	-
	Med	Watts	470	450	445	410	388	359	338	321	-
		Cfm	1302	1264	1205	1163	1081	940	873	783	-
	High	Watts	660	635	610	575	540	505	485	460	-
		Cfm	1700	1660	1581	1450	1297	1190	1095	999	-
042 †	Low	Watts	478	458	440	411	378	350	327	317	-
		Cfm	1303	1270	1224	1179	1126	1022	911	816	-
	Med	Watts	481	468	450	438	404	370	338	320	-
		Cfm	1310	1280	1241	1181	1110	1022	943	811	-
	High	Watts	-	798	678	647	618	578	540	500	460
		Cfm	-	1736	1688	1618	1510	1421	1309	1187	1060
048 †	Low	Watts	-	-	801	760	730	688	650	600	570
		Cfm	-	-	1898	1841	1757	1682	1564	1429	1333
	Med	Watts	-	-	-	-	-	-	-	-	-
		Cfm	-	-	-	-	-	-	-	-	-
	High	Watts	-	-	870	842	818	782	696	632	628
		Cfm	-	-	2000	1903	1799	1718	1625	1446	1365
060 †	Low	Watts	890	850	810	790	735	680	580	480	422
		Cfm	1834	1820	1791	1762	1703	1640	1415	1159	950
	Med	Watts	1040	1018	1000	950	890	835	790	650	580
		Cfm	2230	2102	2025	1960	1901	1855	1752	1468	1121
	High	Watts	1073	1038	1001	958	896	840	800	691	575
		Cfm	2230	2202	2160	2122	2052	1926	1791	1588	1202

† 460-v motors are 2-speed.
 Air delivery values are based on operating voltage of 230-v. or 460-v., dry coil, without filter or electric heater. Deduct wet coil, filter, and electric heater pressure drops to obtain external static pressure available for ducting.
 Do not operate the unit at a cooling airflow that is less than 350 cfm for each 12,000 Btuh of rated cooling capacity. Evaporator coil frosting may occur at airflows below this point.
 Dashes indicate portions of the table that are beyond the blower motor capacity or are not recommended.

- c. Reassemble blower into housing. Place upper orifice ring on blower to judge location of the blower wheel. Blower wheel should be approximately 0.2-in. below bottom of orifice ring when centered correctly. Be sure setscrews are tightened on motor and are not on round part of shaft.
- d. Set upper orifice ring in place with 3 screws removed in step 1.
- e. Replace top access panel.

PROCEDURE 4—OUTDOOR COIL, INDOOR COIL, AND CONDENSATE DRAIN PAN

Inspect the outdoor coil, indoor coil, and condensate drain pan at least once heating and cooling season. Proper inspection and cleaning requires the removal of the unit top. See Unit Top Removal section *above*.

Remove all obstructions (including weeds and shrubs) that interfere with the airflow through the outdoor coil. Straighten bent fins with a fin comb. If coated with dirt or lint, clean the coils with a vacuum cleaner, using a soft brush attachment. Be careful not to bend the fins. If coated with oil or grease, clean the coils with a mild detergent-and-water-solution. Rinse coils with clear water, using a garden hose. Be careful not to splash water on motors, insulation, wiring or air filter(s). For best results, spray outdoor-coil fins from inside to outside the unit. On units with an outer and inner outdoor coil, be sure to clean between the coils. Be sure to flush all dirt and debris from the unit base.

Inspect the drain pan and condensate drain line when inspecting the coils. Clean the drain pan and condensate drain by removing all foreign matter from the pan. Flush the pan and drain tube with clear water. Do not splash water on the insulation, motor, wiring, or air filter(s). If the drain tube is restricted, clear it with a “plumbers snake” or similar probe device. Ensure that the auxiliary drain port above the drain tube is also clear.

Table 5—Wet Coil Pressure Drop

UNIT SIZE PH1Z	AIRFLOW (CFM)	PRESSURE DROP (IN. WG)
024	600	0.02
	700	0.05
	800	0.06
	900	0.07
030	900	0.06
	1000	0.06
	1200	0.08
036	1000	0.07
	1200	0.09
	1400	0.11
	1600	0.12
042	1000	0.04
	1200	0.06
	1400	0.08
	1600	0.09
048	1400	0.07
	1600	0.08
	1800	0.09
060	1700	0.07
	1800	0.08
	2100	0.09
	2300	0.10

Table 6—Filter Pressure Drop (in. wg)

UNIT SIZE PH1Z	FILTER SIZE (IN.)	CFM									
		500	600	700	800	900	1000	1100	1200	1300	1400
024-042	24 x 24	0.06	0.07	0.08	0.08	0.09	0.09	0.09	0.10	0.11	0.12
048, 060	24 x 30	-	-	-	-	-	-	-	-	0.08	0.09

UNIT SIZE PH1Z	FILTER SIZE (IN.)	CFM								
		1500	1600	1700	1800	1900	2000	2100	2200	2300
024-042	24 x 24	0.14	0.15	-	-	-	-	-	-	-
048,060	24 x 30	0.10	0.11	0.12	0.13	0.14	0.15	0.16	0.17	0.18

Table 7—Accessory Electric Heat Pressure Drop
(in. wg)

HEATER KW 5-20	CFM								
	600	800	1000	1200	1400	1600	1800	2000	2200
	0.06	0.08	0.10	0.13	0.15	0.18	0.20	0.23	0.25

PROCEDURE 5—OUTDOOR FAN

⚠ CAUTION: Keep the Outdoor fan free from all obstructions to ensure proper cooling operation. Never place articles on top of the unit. Damage to unit may result.

1. Shut off unit power supply and install lockout tag.
2. Remove outdoor-fan assembly (grille, motor, motor cover, and fan) by removing screws and flipping assembly onto unit top cover.
3. Loosen fan hub setscrews.
4. Adjust fan height as shown in Fig. 21 or 22.
5. Tighten setscrews.
6. Replace outdoor-fan assembly.

PROCEDURE 6—ELECTRICAL CONTROLS AND WIRING

Inspect and check the electrical controls and wiring annually. *Be sure to turn off the electrical power to the unit and install lockout tag.* Remove the top panel to locate all the electrical controls and wiring. Check all electrical connections for tightness. Tighten all screw connections. If any smoky or burned connections are noticed, disassemble the connection, clean all the parts, restrip the wire end and reassemble the connection properly and securely.

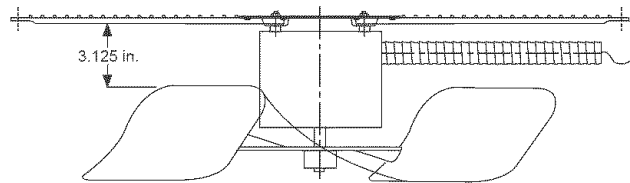

C00021

Fig. 21—Outdoor-Fan Adjustment (024–048 Size)

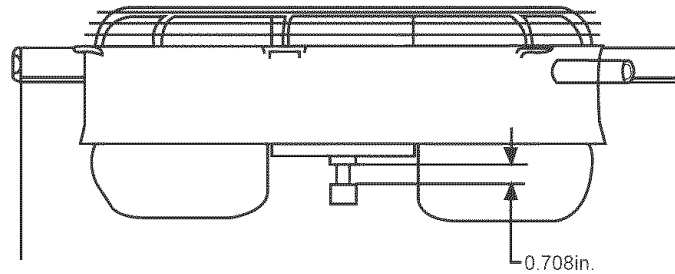

C02017

Fig. 22—Outdoor-Fan Adjustment (060 Size)

Check to ensure no wires are touching refrigerant tubing or sharp sheet metal edges. Move and secure wires to isolate from tubing and sheet metal edges.

After inspecting the electrical controls and wiring, replace all the panels. Start the unit, and observe at least one complete cooling cycle to ensure proper operation. If discrepancies are observed in operating cycle, or if a suspected malfunction has occurred, check each electrical component with the proper electrical instrumentation. Refer to the unit wiring label when making these checkouts.

NOTE: Refer to the Sequence of Operation section, as an aid in determining proper control operation.

PROCEDURE 7—REFRIGERANT CIRCUIT

Inspect all refrigerant tubing connections and the unit base for oil accumulations annually. Detecting oil generally indicates a refrigerant leak.

If oil is detected or if low cooling performance is suspected, leak-test all refrigerant tubing using an electronic leak-detector, or liquid-soap solution. If a refrigerant leak is detected, refer to Check for Refrigerant Leaks section. (See Table of Contents for page number.)

If no refrigerant leaks are found and low cooling performance is suspected, refer to Refrigerant Charge. (See Table of Contents for page number.)

PROCEDURE 8—INDOOR AIRFLOW

The cooling airflow does not require checking unless improper performance is suspected. *If a problem exists, be sure that all supply- and return-air grilles are open and free from obstructions, and that the air filter is clean.* When necessary, refer to Indoor Airflow and Airflow Adjustments section to check the system airflow.

PROCEDURE 9—METERING DEVICES

Refrigerant metering devices are fixed orifices and are located in the inlet header to the indoor and outdoor coils.

Check valves are also located in the liquid lines near the strainers. The check valves are the smaller of the two components.

PROCEDURE 10—LUBRICATION

COMPRESSOR—The compressor is charged with the correct amount of oil at the factory.

FAN MOTOR BEARINGS—Fan motor bearings are permanently lubricated. No further lubrication of outdoor or indoor fan motors is required.

PROCEDURE 11—LIQUID LINE STRAINER

The liquid line strainer (to protect metering device) is made of wire mesh and is located in the liquid line on the inlet side of the metering device.

Check valves are also located in the liquid lines near the strainers. The Strainers are the larger of the two components.

PROCEDURE 12—HIGH FLOW VALVES

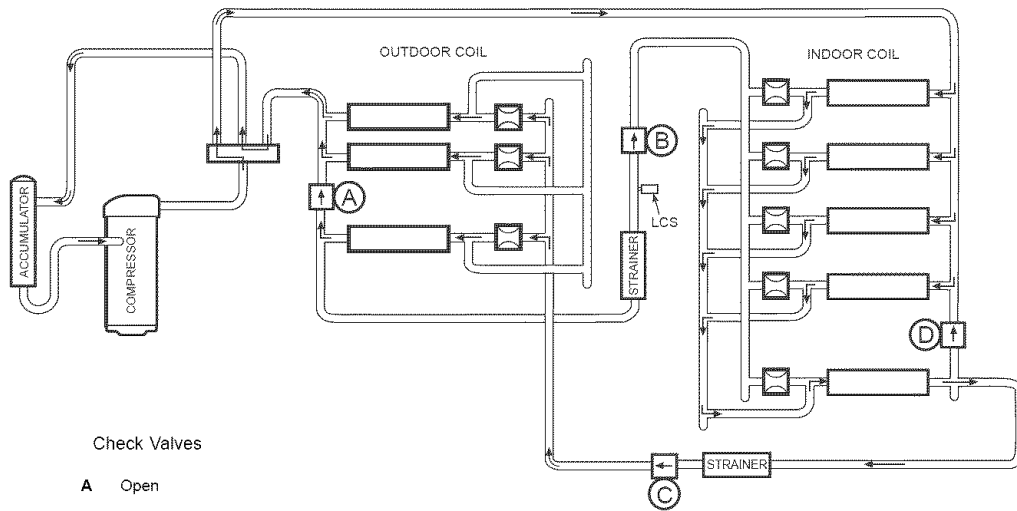

Located on the compressor hot gas and suction tubes are High Flow Valves. Large black plastic caps distinguish these valves with O-rings located inside the caps. These valves can not be accessed for service in the field. Ensure the plastic caps are in place and tight or the possibility of refrigerant leakage could occur.



Check Valves

- A** Open
- B** Closed
- C** Open
- D** Closed

LEGEND

- LCS** Loss of Charge Switch
-  Acutrol Metering Device
-  Check Valve (Arrow indicates direction of flow)

HEATING CYCLE

1. Hot gas from compressor flows through the 4-way valve and is directed to the cooling liquid line check valve. It is then condensed and directed through subcooling circuits and out to the strainer and the check valve in the heating liquid line.
2. The refrigerant then feeds the outdoor coil through the Acutrol metering device on each circuit.
3. Each circuit evaporates the refrigerant and the circuits are combined in the outdoor header with some of the circuits flowing through the check valve.
4. The refrigerant then flows through the 4-way valve, accumulator, and back to the compressor.

C95045

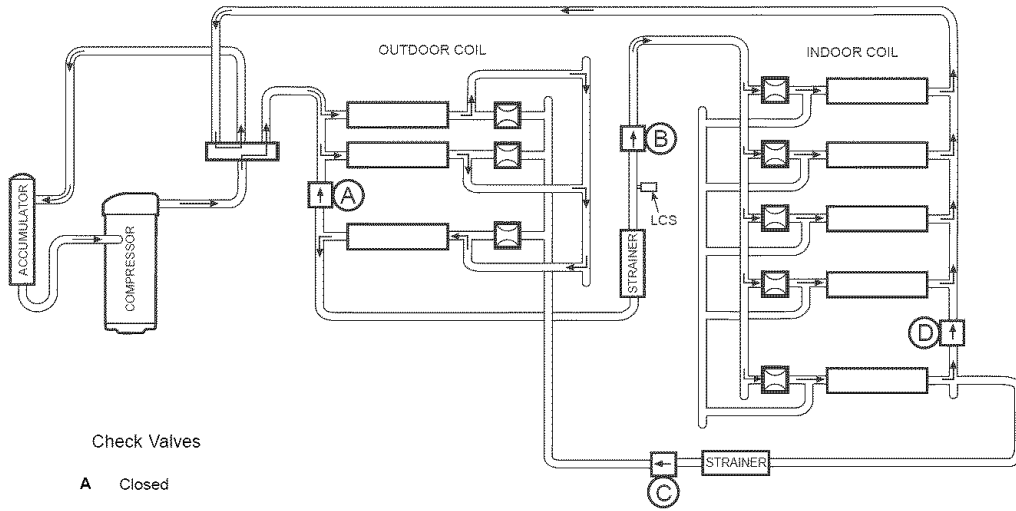

Fig. 23—Typical Heat Pump Operation, Heating Mode



Check Valves

- A** Closed
- B** Open
- C** Closed
- D** Open

LEGEND

- LCS** Loss of Charge Switch
-  Acutrol Metering Device
-  Check Valve (Arrow indicates direction of flow)

COOLING CYCLE

1. Hot gas from compressor flows through the 4-way valve and is directed to the heating liquid line check valve. It is then condensed and subcooled through converging circuits. Refrigerant leaves the outdoor coil by way of the strainer and the check valve in the cooling liquid line.
2. The refrigerant then feeds the indoor coil through the Acutrol metering device on each circuit.
3. Each circuit evaporates the refrigerant and the circuits are combined in the indoor coil header with some of the circuits flowing through the check valve.
4. The refrigerant then flows through the 4-way valve, accumulator, and back to the compressor.

C95044

Fig. 24—Typical Heat Pump Operation, Cooling Mode

Balance Point Worksheet

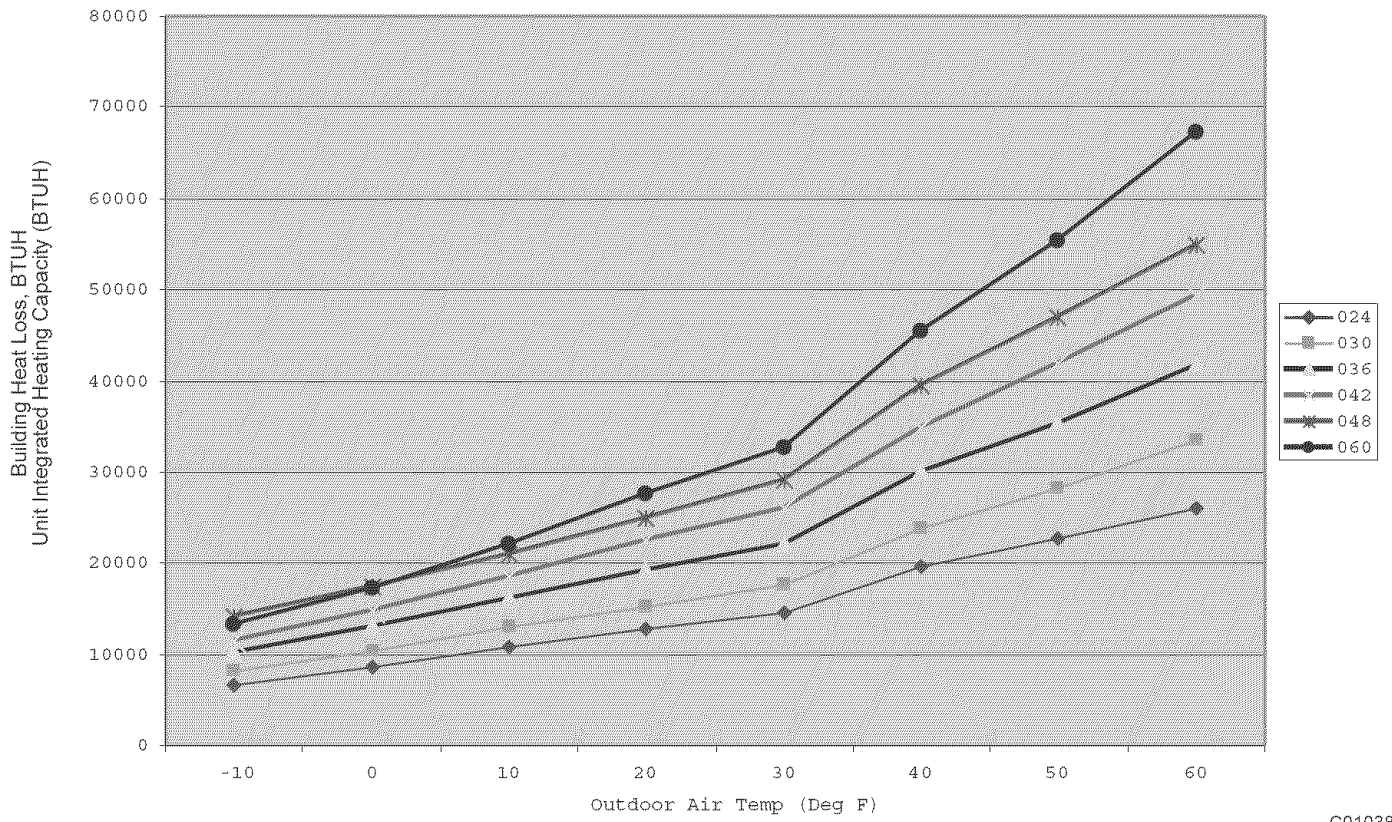

Fig. 25-PH1Z Balance Point Chart

C01038

Table 8—Troubleshooting—Cooling and Heating

SYMPTOM	CAUSE	REMEDY
Compressor and outdoor fan will not start.	Power Failure	Call power company
	Loss of Charge	Evaluate unit for possible refrigerant leak
	Switch open	Replace fuse or reset circuit breaker
	Fuse blown or circuit breaker tripped	Replace component
	Defective thermostat, contractor, transformer, or control relay	Determine cause and correct
	Insufficient line voltage	Check wiring diagram and rewire correctly
	Incorrect or faulty wiring	Lower thermostat setting below room temperature
Compressor will not start but outdoor fan runs.	Thermostat setting too high	Check wiring and repair or replace
	Faulty wiring or loose connections in compressor circuit	Determine cause
	Compressor motor burned out, seized, or internal overload open	Replace compressor
	Defective run/start capacitor, overload, start relay	Determine cause and replace
	One leg of 3-phase power dead	Replace fuse or reset circuit breaker
Compressor cycles (other than normally satisfying thermostat).	Determine cause	Determine cause
	Low input voltage (20 percent low)	Replace fuse or reset circuit breaker
	Refrigerant overcharge or undercharge	Determine cause and correct
	Loss of Charge	Recover refrigerant, evacuate system, and recharge to capacities shown on nameplate
	Switch open	Evaluate unit for possible refrigerant leak
	Defective compressor	Replace and determine cause
	Insufficient line voltage	Determine cause and correct
Compressor operates continuously.	Blocked outdoor coil (cooling)	Determine cause and correct
	Defective run/start capacitor, overload or start relay	Determine cause and replace
	Defective thermostat	Replace thermostat
	Faulty outdoor-fan motor or capacitor	Replace
	Restriction in refrigerant system	Locate restriction and remove
	Dirty air filter	Replace filter
	Unit undersized for load	Decrease load or increase unit size
	Thermostat set too low	Reset thermostat
	Low refrigerant charge	Locate leak, repair, and recharge
	Leaking valves in compressor	Replace compressor
Excessive head pressure.	Frosted outdoor coil with incorrect defrost operation (heating)	Check defrost time settings. Reset as necessary. Check defrost temperature switch. Replace as necessary.
	Air in refrigerant system	Recover refrigerant, evacuate system, and recharge
	outdoor coil dirty or restricted	Clean coil or remove restriction
	Dirty air filter	Replace filter
	Dirty outdoor coil	Clean coil
Head pressure too low.	Refrigerant overcharged	Recover excess refrigerant
	Air in refrigerant system	Recover refrigerant, evacuate system, and recharge
	Outdoor or indoor air restricted or air is recirculating	Determine cause and correct
Excessive suction pressure.	Low refrigerant charge	Check for leaks, repair and recharge
	Compressor valves leaking	Replace compressor
Suction pressure too low.	Restriction in liquid tube	Remove restriction
	High heat load	Check for source and eliminate
	Compressor valves leaking	Replace compressor
	Refrigerant overcharged	Recover excess refrigerant
Compressor runs but outdoor fan does not.	Dirty air filter (cooling)	Replace Filter
	Low refrigerant charge	Check for leaks, repair, and recharge
	Metering device or low side restricted	Remove source of restriction
	Insufficient indoor airflow (cooling)	Increase air quantity
	Temperature too low in conditioned area (cooling)	Check filter- replace if necessary
	Outdoor ambient below 40°F (cooling)	Reset thermostat
Compressor runs but outdoor fan does not.	Field-installed filter-drier restricted	Install low-ambient kit
	Normally closed contacts on defrost board open	Replace
		Check condition of relay on board. Replace board if necessary.

START-UP CHECKLIST
(REMOVE AND STORE IN JOB FILE)

I. PRELIMINARY INFORMATION

Model No
Serial No
Date
Technician
Customer Information(Name/Address)

II. PRE-START-UP

- Verify that all packing materials have been removed from unit
- Verify that condensate connection is installed per installation instructions
- Check all electrical connections and terminals for tightness
- Check wire proximity to refrigerant tubes and sheet metal edges
- Check that indoor (indoor) air filter is clean and in place
- Verify that unit installation is level
- Check fan wheel propeller for location in housing and setscrew tightness

III. START-UP

Supply Voltage: L1-L2 _____ L2-L3 _____ L3-L1 _____
Compressor Amps: L1(C) _____ L2(S) _____ L3(R) _____
Indoor Fan Amps: _____ Outdoor Fan Amps: _____

TEMPERATURE-Cooling Mode

Outdoor Air Temperature: _____ DB _____ WB
Return-Air Temperature: _____ DB _____ WB
Cooling Supply Air: _____ DB _____ WB

PRESSURES-Cooling Mode

Refrigerant Suction _____ psig
Suction Line Temp* _____
Refrigerant Discharge _____ psig
Discharge Temp† _____

TEMPERATURE-Heating Mode

Outdoor Air Temperature: _____ DB _____ WB
Return-Air Temperature: _____ DB _____ WB
Cooling Supply Air: _____ DB _____ WB

PRESSURES-Heating Mode

Refrigerant Suction _____ psig
Suction Line Temp* _____
Refrigerant Discharge _____ psig
Discharge Temp† _____

- Verify Refrigerant charge using charging tables
- Verify that 3-phase scroll compressor is rotating in correct direction.

*Measured at suction inlet to compressor
†Measured at liquid line leaving outdoor coil

