

Installation & Start-up Instructions



PY1P, PY2P Single Packaged Gas Heating/ Electric Cooling Units

NOTE: Read the entire instruction manual before starting the installation.

TABLE OF CONTENTS

SAFETY CONSIDERATIONS.....	2
INTRODUCTION.....	3
RECEIVING AND INSTALLATION.....	3
CHECK EQUIPMENT.....	3
IDENTIFY UNIT.....	3
INSPECT SHIPMENT.....	3
INSTALLATION.....	3
PROVIDE UNIT SUPPORT.....	3
ROOF CURB.....	3
SLAB MOUNT.....	3
GROUND MOUNT.....	3
FIELD FABRICATE DUCTWORK.....	3
PROVIDE CLEARANCES.....	6
RIG AND PLACE UNIT.....	8
CONNECT CONDENSATE DRAIN.....	8
INSTALL FLUE HOOD.....	8
INSTALL GAS PIPING.....	9
INSTALL DUCT CONNECTIONS.....	12
CONFIGURING UNITS FOR DOWNFLOW (VERTICAL) DISCHARGE.....	12
INSTALL ELECTRICAL CONNECTIONS.....	14
HIGH-VOLTAGE CONNECTIONS.....	14
SPECIAL PROCEDURES FOR 208-V OPERATION.....	15
CONTROL VOLTAGE CONNECTIONS.....	15
HEAT ANTICIPATOR SETTING.....	15
TRANSFORMER PROTECTION.....	15
PRE-START-UP.....	16
START-UP.....	18
CHECK FOR REFRIGERANT LEAKS.....	18
START-UP HEATING AND MAKE ADJUSTMENTS.....	18
CHECK HEATING CONTROL.....	18
CHECK GAS INPUT.....	22
ADJUST GAS INPUT.....	22
CHECK BURNER FLAME.....	23
AIRFLOW AND TEMPERATURE RISE.....	23
HEATING SEQUENCE OF OPERATION.....	23
LIMIT SWITCHES.....	23
AUXILIARY LIMIT SWITCH (ROLLOUT).....	24
START-UP COOLING AND MAKE ADJUSTMENTS.....	24
CHECKING COOLING CONTROL OPERATION.....	24
CHECKING AND ADJUSTING REFRIGERANT CHARGE.....	24
INDOOR AIRFLOW AND AIRFLOW ADJUSTMENTS.....	25
COOLING SEQUENCE OF OPERATION.....	25
MAINTENANCE.....	26
AIR FILTER.....	28
EVAPORATOR BLOWER AND MOTOR.....	28
FLUE GAS PASSAGEWAYS.....	30
COMBUSTION-AIR BLOWER.....	30
LIMIT SWITCH.....	31
BURNER IGNITION.....	31

MAIN BURNERS	31
CONDENSER COIL, EVAPORATOR COIL, AND CONDENSATE DRAIN PAN.....	33
CONDENSER FAN	33
ELECTRICAL CONTROLS AND WIRING	34
REFRIGERANT CIRCUIT.....	35
GAS INPUT	35
EVAPORATOR AIRFLOW	35
METERING DEVICE — ACUTROL DEVICE	35
LIQUID LINE STRAINER	35
TROUBLESHOOTING	35
START-UP CHECKLIST.....	35
NOTE TO INSTALLER — Before the installation, READ THESE INSTRUCTIONS CAREFULLY AND COMPLETELY. Also, make sure the User's Manual and Replacement Guide are left with the unit after installation. The furnace is NOT to be used for temporary heating of buildings or structures under construction.	

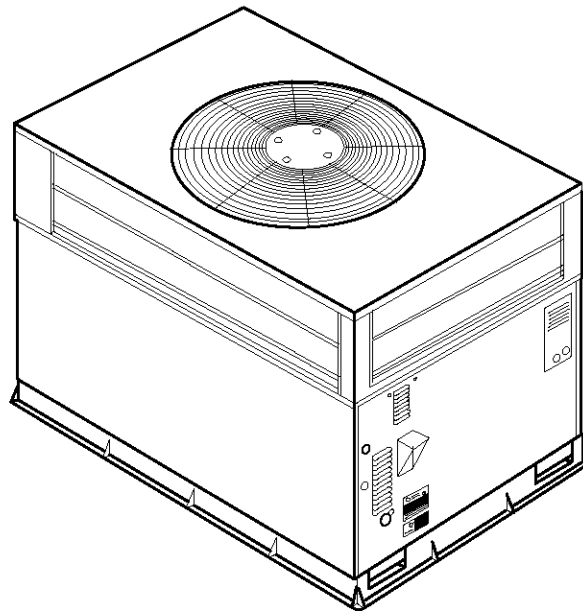

A99338

**Fig. 1—Unit PY1P and PY2P
(Low NO_x Model Available)**

SAFETY CONSIDERATIONS

Installation and servicing of air-conditioning equipment can be hazardous due to system pressure and electrical components. Only trained and qualified personnel should install, repair, or service air-conditioning equipment.

Untrained personnel can perform basic maintenance functions of cleaning coils and filters. All other operations should be performed by trained service personnel. When working on air-conditioning equipment, observe precautions in the literature, tags, and labels attached to the unit, and other safety precautions that may apply.

Follow all safety codes. Wear safety glasses and work gloves. Use quenching cloth for unbrazing operations. Have fire extinguisher available for all brazing operations.

⚠ WARNING: Improper installation, adjustment, alteration, service, maintenance, or use can cause carbon monoxide poisoning, fire, or an explosion which can result in personal injury or unit damage. Consult a qualified installer, service agency, or gas supplier for information or assistance. The qualified installer or agency must use only factory-authorized kits or accessories when modifying this product.

⚠ WARNING: Before performing service or maintenance operations on unit, turn off gas supply to unit. Then turn off unit main power switch and install lockout tag. Electrical shock or explosion could cause serious injury or death.

Recognize safety information. This is the safety-alert symbol ⚠ . When you see this symbol in instructions or manuals, be alert to the potential for personal injury.

Understand the signal words DANGER, WARNING, CAUTION, and NOTE. These words are used with the safety-alert symbol. DANGER identifies the most serious hazards which **will** result in serious injury or death. WARNING signifies a hazard which **could** result in serious injury or death. CAUTION is used to identify unsafe practices which **would** result in minor personal injury or product and property damage. NOTE is used to highlight suggestions which **will** result in enhanced installation, reliability, or operation.

These instructions cover minimum requirements and conform to existing national standards and safety codes. In some instances, these instructions exceed certain local codes and ordinances, especially those that may not have kept up with changing residential construction practices. We require these instructions as a minimum for a safe installation.

INTRODUCTION

The PY1P and PY2P units (See Fig. 1) are fully self-contained, combination Category I gas heating/electric cooling units designed for outdoor installation (See Fig. 2 and 3 for unit dimensions). All unit sizes have return and discharge openings for both horizontal and downflow configurations, and are factory shipped with all downflow duct openings covered. Units may be installed either on a rooftop, a cement slab, or directly on the ground if local codes permit (See Fig. 4 for roof curb dimensions).

Models with an N in the thirteenth position of the model number are dedicated Low NO_x units designed for California installations.

These models meet the California maximum oxides of nitrogen (NO_x) emissions requirements of 40 nanograms/joule or less as shipped from the factory and must be installed in California Air Quality Management Districts where a Low NO_x rule exists.

RECEIVING AND INSTALLATION

PROCEDURE 1—CHECK EQUIPMENT

A. IDENTIFY UNIT

The unit model number and serial number are stamped on unit identification plate. Check this information against shipping papers and job data. Verify unit voltage and amperage requirements listed on unit rating plate agree with power supply provided to unit.

B. INSPECT SHIPMENT

Inspect for shipping damage while unit is still on shipping pallet. If unit appears to be damaged or is torn loose from its anchorage, have it examined by transportation inspectors before removal. Forward claim papers directly to transportation company. Manufacturer is not responsible for any damage incurred in transit.

Check all items against shipping list. Immediately notify the nearest distributor if any item is missing.

To prevent loss or damage, leave all parts in original packages until installation.

C. INSTALLATION

1. Remove unit from shipping carton. Leave top shipping skid on the unit as a spreader bar to prevent the rigging straps from damaging the unit. If the wood skid is not available, use a spreader bar of sufficient length to protect unit from damage.
2. Position the lifting bracket assembly around the base of the unit. Be sure the strap does not twist.
3. Place each of the 4 metal lifting brackets into the rigging holds in the composite pan.
4. Thread lifting bracket strapping around bottom perimeter of unit as follows:
 - a. Open lever of tension buckle (ratchet type).
 - b. Feed strapping through tension buckle as shown in Fig. 7A.
 - c. Pull strapping through tension buckle unit taut.
 - d. Snap lever down to lock strap in tension buckle. To release strapping, squeeze safety latch, lift lever, and pull webbing outward.
5. Tighten the tension buckle until it is taut. Lifting brackets must be secure in the rigging holds.
6. Attach field-supplied clevis or hook of sufficient strength to hole in the lifting bracket (See Fig. 7B).
7. Attach the 2 safety straps directly to the clevis or hook at the 4 rigging brackets. **DO NOT** attach the safety straps to the lifting brackets (See Fig. 7B).
8. Position lifting point directly over the unit's center of gravity.
9. Lift unit. When unit is directly over the roof curb, remove the 2 safety straps. Lower the equipment onto the roof curb.

PROCEDURE 2—PROVIDE UNIT SUPPORT

A. ROOF CURB

Install accessory roof curb in accordance with instructions shipped with curb (See Fig. 4 for roof curb dimensions). Install insulation, cant strips, roofing, and flashing. Ductwork must be attached to curb.

IMPORTANT: The gasketing of the unit to the roof curb is critical for a watertight seal. Install gasketing material supplied with the roof curb. Improperly applied gasketing can also result in air leaks and poor unit performance.

Curb should be level to within 1/4 in. This is necessary for unit drain to function properly. Refer to accessory roof curb installation instructions for additional information as required.

B. SLAB MOUNT

Place the unit on a solid, level concrete pad that is a minimum of 4 in. thick with 2 in. above grade. The slab should be flush on the compressor end of the unit (to allow condensate drain installation) and should extend 2 in. on the three remaining sides of the unit (See Fig. 6). Do not secure the unit to the slab *except* when required by local codes.

C. GROUND MOUNT

The unit may be installed either on a slab or placed directly on the ground if local codes permit. Place the unit on level ground prepared with gravel for condensate discharge.

PROCEDURE 3—FIELD FABRICATE DUCTWORK

Secure all ducts to roof curb and building structure on vertical discharge units. *Do not connect ductwork to unit.* For horizontal applications, unit is provided with flanges on the horizontal openings. Installation of flexible duct connector is recommended to prevent transmission of vibration and/or noise to structure. All ductwork should be secured to the flanges. Insulate and weatherproof all external ductwork, joints, and roof openings with counter flashing and mastic in accordance with applicable codes.

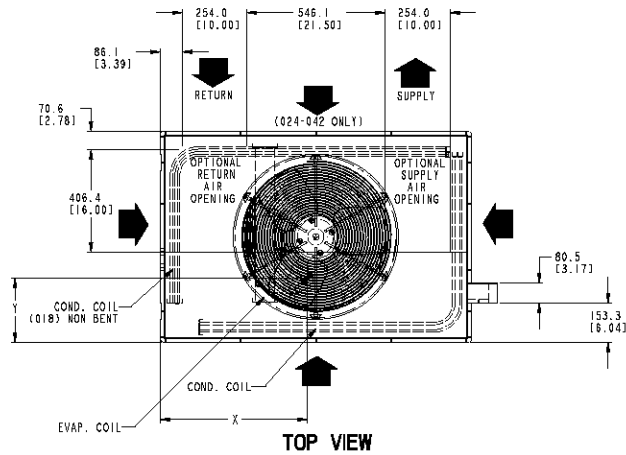
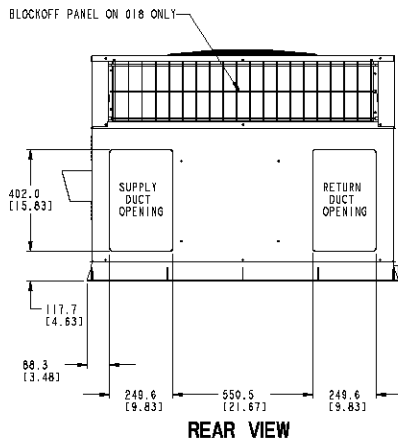

REQUIRED CLEARANCE TO COMBUSTIBLE MATL.

	INCHES	[mm]
TOP OF UNIT	14.00	[355.6]
DUCT SIDE OF UNIT	2.00	[50.8]
SIDE OPPOSITE DUCTS	14.00	[355.6]
BOTTOM OF UNIT	0.50	[12.7]
ELECTRIC HEAT PANEL	36.00	[914.4]

NEC. REQUIRED CLEARANCES.

	INCHES	[mm]
BETWEEN UNITS, POWER ENTRY SIDE	42.00	[1066.8]
UNIT AND UNGROUNDED SURFACES, POWER ENTRY SIDE	36.00	[914.0]
UNIT AND BLOCK OR CONCRETE WALLS AND OTHER GROUNDED SURFACES, POWER ENTRY SIDE	42.00	[1066.8]

LEGEND

- CG - Center of Gravity
- COND - Condenser
- EVAP - Evaporator
- NEC - National Electrical Code
- REQ'D - Required

NOTE: Dimensions are in in. [mm]

REQUIRED CLEARANCE FOR OPERATION AND SERVICING

	INCHES	[mm]
EVAP. COIL ACCESS SIDE	36.00	[914.0]
POWER ENTRY SIDE (EXCEPT FOR NEC REQUIREMENTS)	36.00	[914.0]
UNIT TOP	48.00	[1219.2]
SIDE OPPOSITE DUCTS	36.00	[914.0]
DUCT PANEL	12.00	[304.8]

*MINIMUM DISTANCES: IF UNIT IS PLACED LESS THAN 12.00 [304.8] FROM WALL SYSTEM, THEN SYSTEM PERFORMANCE MAYBE COMPROMISE.

Note: Wire Grilles are a field installed option.

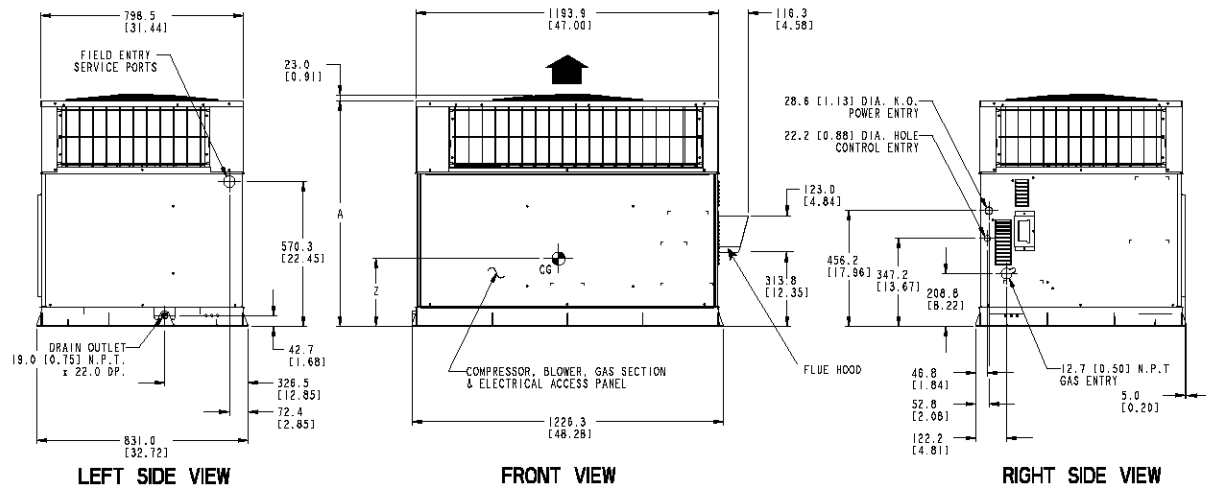

C00055

UNIT	ELECTRICAL CHARACTERISTICS	UNIT WEIGHT		UNIT HEIGHT IN. (MM) "A"	CENTER OF GRAVITY IN. (MM)		
		lb	kg		X	Y	Z
PY1P018040	208/230-1-60	249.0	113.2	35.02 (889.5)	20.0 (508.0)	14.0 (355.6)	15.0 (381.0)
PY1P024040/060	208/230-1-60	280.0	127.3	35.02 (889.5)	22.5 (571.5)	13.0 (330.2)	15.0 (381.0)
PY1P030040/060	208/230-1-60, 208/230-3-60	280.0	127.3	35.02 (889.5)	21.5 (546.1)	13.75 (349.3)	15.0 (381.0)
PY1P036060/090	208/230-1-60, 208/230-3-60, 460-3-60	320.0	145.1	37.02 (940.3)	22.5 (571.5)	14.0 (355.6)	13.0 (330.2)
PY1P042060/090	208/230-1-60, 208/230-3-60, 460-3-60	355.0	161.4	35.02 (889.5)	21.5 (546.1)	13.5 (342.9)	13.0 (330.2)
PY2P024040/060	208/230-1-60	290.0	131.5	37.02 (940.3)	22.0 (558.8)	14.5 (368.3)	16.0 (406.4)
PY2P030040/060	208/230-1-60, 208/230-3-60	313.0	142.0	39.02 (991.1)	22.0 (558.8)	15.3 (387.4)	17.6 (447.0)
PY2P036060/090	208/230-1-60, 208/230-3-60, 460-3-60	321.0	145.6	35.02 (889.5)	22.0 (558.8)	15.3 (387.4)	16.5 (419.1)

Fig. 2—PY1P018-042 and PY2P024-036 Unit Dimensions

Ducts passing through an unconditioned space must be insulated and covered with a vapor barrier.

If a plenum return is used on a vertical unit, the return should be ducted through the roof deck to comply with applicable fire codes.

A minimum clearance is not required around ductwork. Cabinet return-air static shall not exceed -.25 in. wg.

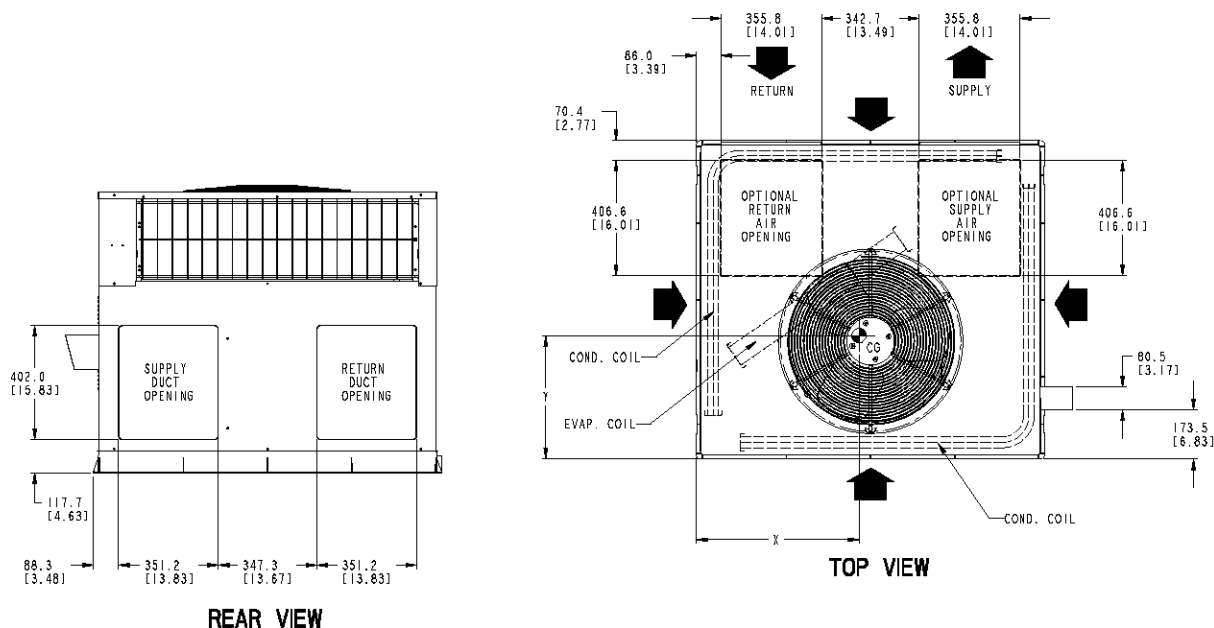

REQUIRED CLEARANCE TO COMBUSTIBLE MATL.

	INCHES [mm]
TOP OF UNIT	14.00 [355.6]
DUCT SIDE OF UNIT	2.00 [50.8]
SIDE OPPOSITE DUCTS	14.00 [355.6]
BOTTOM OF UNIT	0.50 [12.7]
FLUE PANEL	36.00 [914.4]

NEC. REQUIRED CLEARANCES.

	INCHES [mm]
BETWEEN UNITS, POWER ENTRY SIDE	42.00 [1066.8]
UNIT AND UNGROUNDED SURFACES, POWER ENTRY SIDE	36.00 [914.0]
UNIT AND BLOCK OR CONCRETE WALLS AND OTHER GROUNDED SURFACES, POWER ENTRY SIDE	42.00 [1066.8]

REQUIRED CLEARANCE FOR OPERATION AND SERVICING

	INCHES [mm]
EVAP. COIL ACCESS SIDE	36.00 [914.0]
POWER ENTRY SIDE	36.00 [914.0]
(EXCEPT FOR NEC REQUIREMENTS)	
UNIT TOP	48.00 [1219.2]
SIDE OPPOSITE DUCTS	36.00 [914.0]
DUCT PANEL	12.00 [304.8]

*MINIMUM DISTANCES: IF UNIT IS PLACED LESS THAN 12.00 [304.8] FROM WALL SYSTEM, THEN SYSTEM PERFORMANCE MAYBE COMPROMISE.

Note: Wire Grilles are a field installed option.

LEGEND
 CG - Center of Gravity
 COND - Condenser
 EVAP - Evaporator
 NEC - National Electrical Code
 REQ'D - Required

NOTE: Dimensions are in in. [mm]

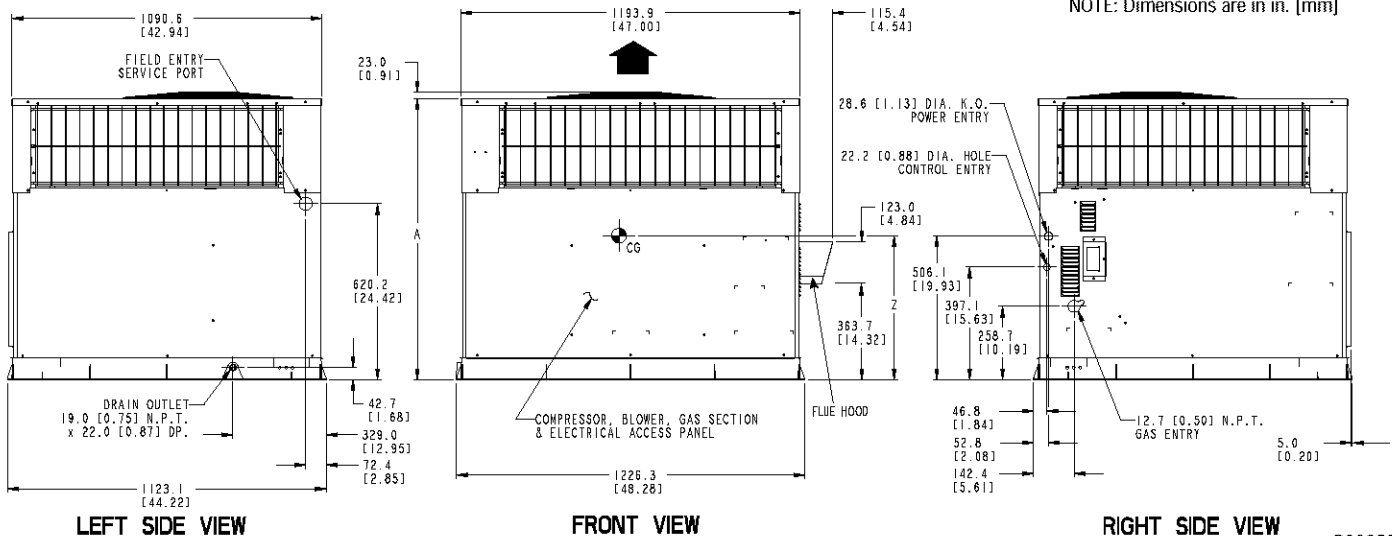

C00056

UNIT	ELECTRICAL CHARACTERISTICS	UNIT WEIGHT		UNIT HEIGHT IN. (MM) "A"	CENTER OF GRAVITY IN. (MM)		
		lb	kg		X	Y	Z
PY1P048090/115/130	208/230-1/60, 208/230-3-60, 460-3-60	415	188.6	38.98 (990.2)	22 (558.5)	16 (406.4)	17 (432.0)
PY1P060090/115/130	208/230-1-60, 208/230-3-60, 460-3-60	450	204.5	38.98 (990.2)	22 (558.5)	16 (406.4)	17 (432.0)
PY2P042060/090	208/230-1-60, 208/230-3-60, 460-3-60	382	173.3	38.98 (990.2)	23.0 (584.2)	16.3 (412.8)	16.6 (421.6)
PY2P048090/115/130	208/230-1-60, 208/230-3-60, 460-3-60	421	191.0	38.98 (990.2)	21.5 (546.1)	16.6 (422.1)	18.0 (457.2)
PY2P060090/115/130	208/230-1-60, 208/230-3-60, 460-3-60	468	212.3	42.98 (1091.1)	23.5 (596.9)	16.3 (412.8)	17.6 (447.0)

Fig. 3—PY1P048-060 and PY2P042-060 Unit Dimensions

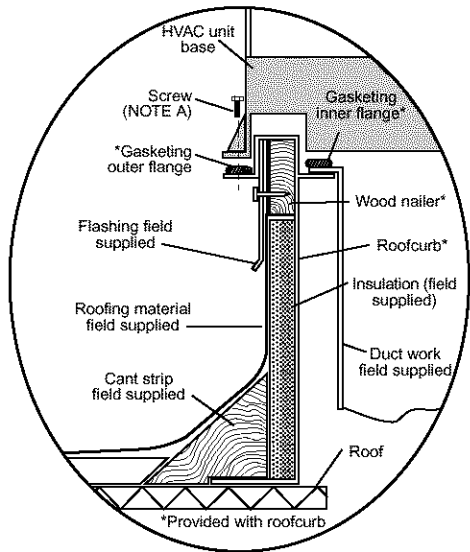

Roof Curb for Small Cabinet

Note A: When unit mounting screw is used, retainer bracket must also be used.

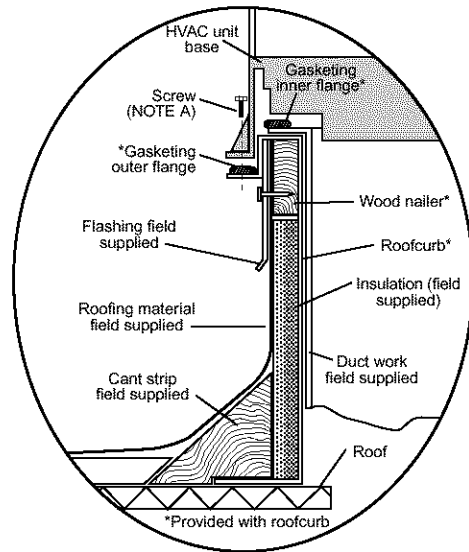

Roof Curb for Large Cabinet

Note A: When unit mounting screw is used, retainer bracket must also be used.

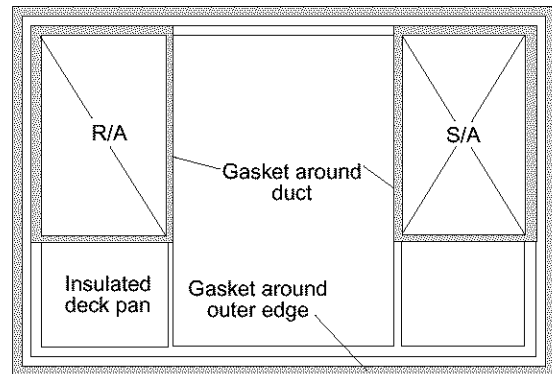
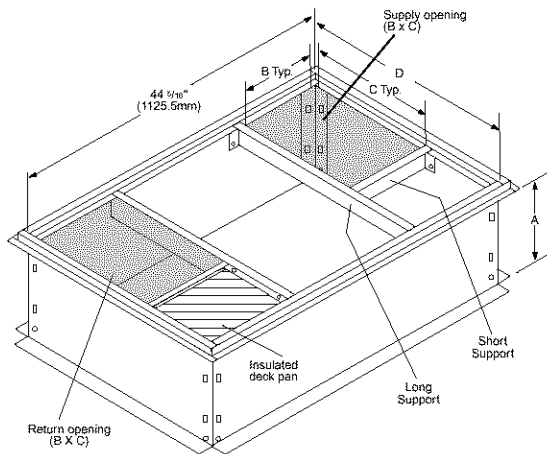

C00076

UNIT SIZE		ODS CATALOG NUMBER	A IN. (MM)	B IN. (MM)	C IN. (MM)	D IN. (MM)
PY1P018-042	PY2P024-036	CPRFCURB006A00	8 (203)	11(279)	161/2 (419)	28-3/4 (730)
		CPRFCURB007A00	14 (356)	11(279)	161/2 (419)	28-3/4 (730)
PY1P048-060	PY2P042-060	CPRFCURB008A00	8 (203)	16 3/16 (411)	17 3/8 (441)	40-1/4 (1022)
		CPRFCURB009A00	14 (356)	16 3/16 (411)	17 3/8 (441)	40-1/4 (1022)

NOTES:

1. Roof curb must be set up for unit being installed.
2. Seal strip must be applied, as required, to unit being installed.
3. Dimensions in () are in millimeters.
4. Roof curb is made of 16-gage steel.
5. Table lists only the dimensions, per part number, that have changed.
6. Attach ductwork to curb (flanges of duct rest on curb).
7. Insulated panels: 1-in. thick fiberglass 1 lb density.
8. Dimensions are in inches.
9. When unit mounting screw is used (see Note A), a retainer bracket must be used as well. This bracket must also be used when required by code for hurricane or seismic conditions. This bracket is available through Micrometl.

Fig. 4—Roof Curb Dimensions

PROCEDURE 4—PROVIDE CLEARANCES

The required minimum operating and service clearances are shown in Fig. 2 and 3. Adequate combustion, ventilation and condenser air must be provided in accordance with section 5.3, Air for Combustion and Ventilation, of the National Fuel Gas Code ANSI (American National Standards Institute) Z223.1 or applicable provisions of local building code. In Canada, follow sections 7.2, 7.3, or 7.4 or Can/CGA. (Canadian Gas Association) B149 Installation Codes or applicable provisions of local building code.

CAUTION: Do not restrict condenser airflow. An air restriction at either the outdoor-air inlet or the fan discharge can be detrimental to compressor life.

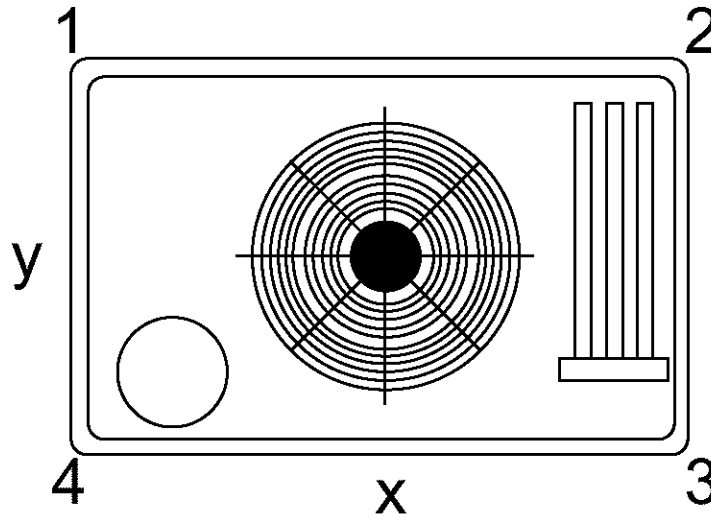

C00070

CORNER #	PY1P							PY2P					
	018	024	030	036	042	048	060	024	030	036	042	048	060
1	47.3	53.2	53.2	59.7	67.5	78.9	85.5	55.1	59.5	61.0	72.6	80.0	88.9
2	44.8	50.4	50.4	56.5	63.9	74.7	81.0	52.2	56.3	57.8	68.8	75.8	84.2
3	77.2	86.8	86.8	97.3	110.1	128.7	139.5	89.9	97.0	99.5	118.4	130.5	145.1
4	79.7	89.6	89.6	106.5	113.6	132.8	144.0	92.8	100.2	102.7	122.2	134.7	149.8
TOTAL WEIGHT	249	280	280	320	355	415	450	290	313	321	382	421	468

Fig. 5—PY1P and PY2P Unit Corner Weights

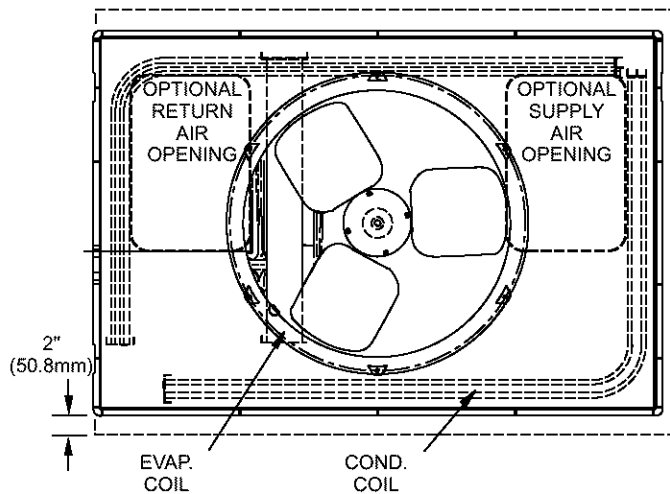

C99014

Fig. 6—Slab Mounting Details

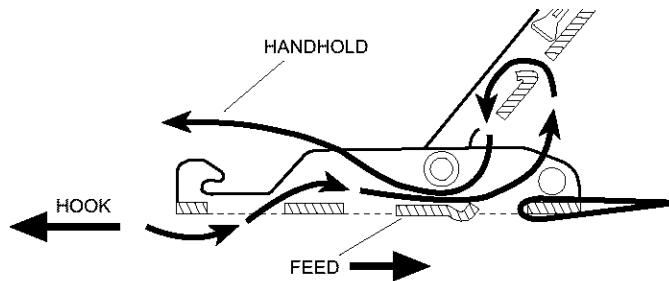

C99067

Fig. 7A—Threading Bolt for Rigging

The condenser fan pulls air through the condenser coil and discharges it through the top cover. Be sure that the fan discharge does not recirculate to the condenser coil. Do not locate the unit in either a corner or under an overhead obstruction. The minimum clearance under a partial overhang (such as a normal house overhang) is 48-in. above the unit top. The maximum horizontal extension of a partial overhang must not exceed 48-in.. Do not place the unit where water, ice, or snow from an overhang or roof will damage or flood the unit. Do not install the unit on carpeting, tile, or other combustible materials. The unit may be installed on wood flooring or on Class A, B, or C roof covering materials.

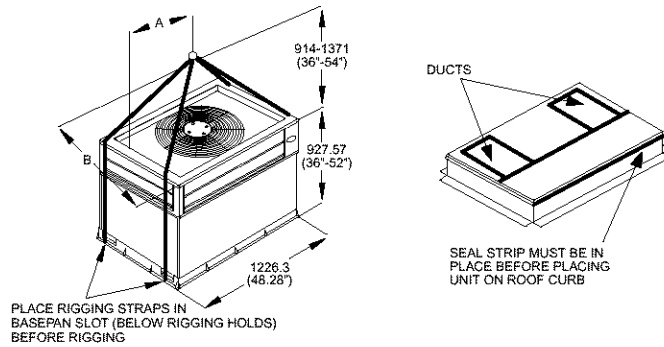

C99015

SIZE	MAXIMUM WEIGHT		A		B	
	lb	kg	in.	mm	in.	mm
UNIT PY1P						
018	271	123.2	20.0	508.0	14.0	355.6
024	302	137.3	22.5	571.5	13.0	330.2
030	302	137.3	21.5	546.1	13.75	349.3
036	342	155.1	22.5	571.5	14.0	355.6
042	377	171.4	21.5	546.1	13.5	342.9
048	437	198.6	22.0	558.5	17.0	432.0
060	472	214.5	22.0	558.5	17.0	432.0
UNIT PY2P						
024	312	142	22.0	558.5	14.50	368.3
030	335	152	22.0	558.5	15.30	388.6
036	343	156	22.0	558.5	15.30	388.6
042	404	183	23.0	584.2	16.3	414.0
048	443	201	21.5	546.1	16.3	414.0
060	490	222	23.5	596.9	16.3	414.3

Fig. 7B—Suggested Rigging

PROCEDURE 5—RIG AND PLACE UNIT

⚠ CAUTION: When installing the unit on a rooftop, be sure the roof will support the additional weight.

Use spreader bars or crate top when rigging the unit. The units must be rigged for lifting (See Fig. 6). Refer to Table 1 and 2 for operating weight. *Use extreme caution to prevent damage when moving the unit. Unit must remain in an upright position during all rigging and moving operations.* The unit must be level within 1/4" for proper condensate drainage; therefore, the ground-level pad or accessory roof curb must be level before setting the unit in place. When a field-fabricated support is used, be sure that the support is level and properly supports the unit. Lifting point should be directly over the center of gravity for the unit.

PROCEDURE 6—CONNECT CONDENSATE DRAIN

NOTE: When installing condensate drain connection be sure to comply with local codes and restrictions.

Models PY1P and PY2P dispose of condensate water through a 3/4 in. NPT fitting which exits through the compressor access panel (See Fig. 2 and 3 for location).

Condensate water can be drained directly onto the roof in rooftop installations (where permitted) or onto a gravel apron in ground-level installations. Install a field-supplied condensate trap at end of condensate connection to ensure proper drainage. Make sure that the outlet of the trap is at least 1 in. lower than the drain pan condensate connection to prevent the pan from overflowing (See Fig. 8). Prime the trap with water. When using a gravel apron, make sure it slopes away from the unit.

If the installation requires draining the condensate water away from the unit, install a 2-in. trap at the condensate connection to ensure proper drainage (See Fig. 8). Make sure that the outlet of the trap is at least 1 in. lower than the drainpan condensate connection. This prevents the pan from overflowing.

Prime the trap with water. Connect a drain tube – using a minimum of 3/4-in. PVC or 3/4-in. copper pipe (all field-supplied) – at the outlet end of the 2-in. trap. Do not undersize the tube. Pitch the drain tube downward at a slope of at least 1-in. for every 10 ft of horizontal run. Be sure to check the drain tube for leaks.

PROCEDURE 7—INSTALL FLUE HOOD

The flue hood assembly is shipped screwed to the coil panel in the indoor blower compartment. Remove the service access panel to locate the assembly (See Fig. 31).

NOTE: Dedicated low NO_x models MUST be installed in California Air Quality Management Districts where a Low NO_x rule exists.

These models meet the California maximum oxides of nitrogen (NO_x) emissions requirements of 40 nanograms/joule or less as shipped from the factory.

NOTE: Low NO_x requirements apply only to natural gas installations.

⚠ CAUTION: The venting system is designed to ensure proper venting. The flue hood assembly must be installed as indicated in this section of the unit installation instructions.

Table 1—Physical Data—Unit PY1P

UNIT SIZE PY1P	018040	024040	024060	030040	030060	036060	036090	042060	042090
NOMINAL CAPACITY (ton)	1½	2	2	2½	2½	3	3	3½	3½
OPERATING WEIGHT (lb.)	249	280	280	280	280	320	320	355	355
COMPRESSORS Quantity	Reciprocating 1								
REFRIGERANT (R-22) Quantity (lb.)	2.6	3.5	3.5	3.65	3.65	4.4	4.4	5.7	5.7
REFRIGERANT METERING DEVICE Orifice ID (in.)	Acutrol™ Device								
	.034	.034	.034	.034	.034	.032	.032	.034	.034
CONDENSER COIL Rows...Fins/in. Face Area (sq ft)	1...17 6.1	1...17 9.1	1...17 9.1	1...17 9.1	1...17 9.1	1...17 10.9	1...17 10.9	1...17 9.1	1...17 9.1
CONDENSER FAN Nominal Cfm Diameter (in.) Motor Hp (Rpm)	2000 22 1/8 (825)	2400 22 1/8 (825)	2400 22 1/8 (825)	2400 22 1/8 (825)	2400 22 1/8 (825)	3000 22 ¼ (1100)	3000 22 ¼ (1100)	3000 22 ¼ (1100)	3000 22 ¼ (1100)
EVAPORATOR COIL Rows...Fins/in. Face Area (sq ft)	2...15 3.1	2...15 3.1	2...15 3.1	2...15 3.1	2...15 3.1	3...15 3.1	3...15 3.1	4...15 3.1	4...15 3.1
EVAPORATOR BLOWER Nominal Airflow (Cfm) Size (in.) Motor HP (Rpm)	600 10 x 10 1/4 (875)	800 10 x 10 1/4 (1075)	800 10 x 10 1/4 (1075)	1000 10 x 10 1/4 (1075)	1000 10 x 10 1/4 (1075)	1200 11 x 10 1/2 (1075)	1200 11 x 10 1/2 (1075)	1400 11 x 10 3/4 (1075)	1400 11 x 10 3/4 (1075)
FURNACE SECTION* Burner Orifice No. (Qty...Drill Size) Natural Gas Burner Orifice No. (Qty...Drill Size) Propane Gas	2...45 2...50	2...45 2...50	2...38 2...46	2...45 2...50	2...38 2...46	2...38 2...46	3...38 3...46	2...38 2...46	3...38 3...46
RETURN-AIR FILTERS (in.)† Throwaway	20 x 20	20 x 20	20 X 20	20 x 20	20 X 20	20 X 24	20 X 24	20 x 24	20 x 24

* Based on altitude of 0 to 2000 ft.

† Required filter sizes shown are based on the larger of the ARI (Air Conditioning and Refrigeration Institute) rated cooling airflow or the heating airflow velocity of 300 ft/minute for throwaway type or 450 ft/minute for high-capacity type. Air filter pressure drop for non-standard filters must not exceed 0.08 in. wg.

Install the flue hood as follows:

1. This installation must conform with local building codes and with the National Fuel Gas Code (NFGC), ANSI Z223.1 (in Canada, CAN/CGA B149.1, and B149.2) or NFPA (National Fire Protection Association) latest revision. Refer to Provincial and local plumbing or wastewater codes and other applicable local codes.
2. Remove flue hood from shipping location (inside the blower compartment). Place vent cap assembly over flue panel. Orient screw holes in vent cap with holes in the flue panel.
3. Secure flue hood to flue panel by inserting a single screw on the right side and the left side of the hood.

PROCEDURE 8—INSTALL GAS PIPING

The gas supply pipe enters the unit through the access hole provided. The gas connection to the unit is made to the 1/2-in. FPT gas inlet on the manual shutoff or gas valve.

Install a gas supply line that runs to the heating section. Refer to Table 3 and the NFGC for gas pipe sizing. *Do not use cast-iron pipe.* It is recommended that a black iron pipe is used. Check the local utility for recommendations concerning existing lines. Size gas supply piping for 0.5 in. wg maximum pressure drop. *Never use pipe smaller than the 1/2-in. FPT gas inlet on the unit gas valve.*

For natural gas applications, the gas pressure at unit gas connection must not be less than 4.0 in. wg or greater than 13 in. wg while the unit is operating. For propane applications, the gas pressure must not be less than 7.0 in. wg or greater than 13 in. wg at the unit connection.

An 1/8-in. NPT plugged tapping, accessible for test gage connection, must be installed immediately upstream of the gas supply connection to the gas valve.

When installing the gas supply line, observe local codes pertaining to gas pipe installations. Refer to the NFGC ANSI Z223.1-1988 NFPA latest edition (in Canada, CAN/CGA B149.1, (2)-M86). In the absence of local building codes, adhere to the following pertinent recommendations:

1. Avoid low spots in long runs of pipe. Grade all pipe 1/4 in. in every 15 ft to prevent traps. Grade all horizontal runs downward to risers. Use risers to connect to heating section and to meter.
2. Protect all segments of piping system against physical and thermal damage. Support all piping with appropriate straps, hangers, etc. Use a minimum of one hanger every 6 ft. For pipe sizes larger than 1/2 in., follow recommendations of national codes.
3. Apply joint compound (pipe dope) sparingly and only to male threads of joint when making pipe connections. Use only pipe dope that is resistant to action of liquefied petroleum gases as specified by local and/or national codes. *Never use Teflon tape.*
4. Install sediment trap in riser leading to heating section (See Fig. 9). This drip leg functions as a trap for dirt and condensate.
5. Install an accessible, external, manual main shutoff valve in gas supply pipe within 6 ft of heating section.
6. Install ground-joint union close to heating section between unit manual shutoff and external manual main shut-off valve.
7. Pressure-test all gas piping in accordance with local and national plumbing and gas codes before connecting piping to unit.

Table 1—Physical Data—Unit PY1P (Continued)

UNIT SIZE PY1P	048090	048115	048130	060090	060115	060130
NOMINAL CAPACITY (ton)	4	4	4	5	5	5
OPERATING WEIGHT (lb.)	415	415	415	450	450	450
COMPRESSORS Quantity	Scroll 1			Reciprocating 1		
REFRIGERANT (R-22) Quantity (lb.)	6.0	6.0	6.0	8.0	8.0	8.0
REFRIGERANT METERING DEVICE Orifice ID (in.)	Acutrol Device					
	.032	.032	.032	.030	.030	.030
CONDENSER COIL Rows...Fins/in. Face Area (sq ft)	1...17 12.3	1...17 12.3	1...17 12.3	2...17 12.3	2...17 12.3	2...17 12.3
CONDENSER FAN Nominal Cfm Diameter (in.) Motor Hp (Rpm)	3600 22 ¼ (1100)	3600 22 ¼ (1100)	3600 22 ¼ (1100)	3600 22 ¼ (1100)	3600 22 ¼ (1100)	3600 22 ¼ (1100)
EVAPORATOR COIL Rows...Fins/in. Face Area (sq ft)	3...15 4.7	3...15 4.7	3...15 4.7	4...15 4.7	4...15 4.7	4...15 4.7
EVAPORATOR BLOWER Nominal Airflow (Cfm) Size (in.) Motor Hp (Rpm)	1600 11 X 10 ¾ (1075)	1600 11 X 10 ¾ (1075)	1600 11 X 10 ¾ (1075)	2000 11 X 10 1.0 (1075)	2000 11 X 10 1.0 (1075)	2000 11 X 10 1.0 (1075)
FURNACE SECTION* Burner Orifice No. (Qty...Drill Size) Natural Gas Burner Orifice No. (Qty...Drill Size) Propane Gas	3...38 3...46	3...33 3...42	3...31 3...41	3...38 3...46	3...33 3...42	3...31 3...41
RETURN-AIR FILTERS (in.)† Throwaway	24 X 30	24 X 30	24 X 30	24 X 30	24 X 30	24 X 30

* Based on altitude of 0 to 2000 ft.

† Required filter sizes shown are based on the larger of the ARI (Air Conditioning and Refrigeration Institute) rated cooling airflow or the heating airflow velocity of 300 ft/minute for throwaway type or 450 ft/minute for high-capacity type. Air filter pressure drop for non-standard filters must not exceed 0.08 in. wg.

Table 2—Physical Data—Unit PY2P

UNIT SIZE PY2P	024040	024060	030040	030060	036060	036090	042060	042090
NOMINAL CAPACITY (ton)	2	2	2½	2½	3	3	3½	3½
OPERATING WEIGHT (lb.)	290	290	313	313	321	321	382	382
COMPRESSORS Quantity	Scroll 1							
REFRIGERANT (R-22) Quantity (lb.)	3.7	3.7	4.4	4.4	5.2	5.2	6.4	6.4
REFRIGERANT METERING DEVICE Orifice ID (in.)	.034	.034	.030	.030	.032	.032	.034	.034
CONDENSER COIL Rows...Fins/in. Face Area (sq ft)	1...17 10.8	1...17 10.8	1...17 12.7	1...17 12.7	2...17 9.1	2...17 9.1	2...17 12.3	2...17 12.3
CONDENSER FAN Nominal Cfm Diameter (in.) Motor Hp (Rpm)	2350 22 1/8 (825)	2350 22 1/8 (825)	2350 22 1/8 (825)	2350 22 1/8 (825)	2350 22 1/8 (825)	2350 22 1/8 (825)	3300 22 1/8 (825)	3300 22 1/8 (825)
EVAPORATOR COIL Rows...Fins/in. Face Area (sq ft)	3...15 3.1	3...15 3.1	3...15 3.1	3...15 3.1	3...15 3.7	3...15 3.7	3...15 4.7	3...15 4.7
EVAPORATOR BLOWER Nominal Airflow (Cfm) Size (in.) Motor Hp (Rpm)	800 10 X 10 ¼ (1075)	800 10 X 10 ¼ (1075)	1000 10 X 10 ¼ (1075)	1000 10 X 10 ¼ (1075)	1200 11 X 10 1/2 (1075)	1200 11 X 10 1/2 (1075)	1400 11 X 10 ¾ (1075)	1400 11 X 10 ¾ (1075)
FURNACE SECTION* Burner Orifice No. (Qty...Drill Size) Natural Gas Burner Orifice No. (Qty...Drill Size) Propane Gas	2...44 2...50	2...38 2...46	2...44 2...50	2...38 2...46	2...38 2...46	3...38 3...46	2...38 2...46	3...38 3...46
RETURN-AIR FILTERS (in.)† Throwaway	20 X 20	20 X 20	20 X 20	20 X 20	20 X 24	20 X 24	24 X 30	24 X 30

* Based on altitude of 0 to 2000 ft.

† Required filter sizes shown are based on the larger of the ARI (Air Conditioning and Refrigeration Institute) rated cooling airflow or the heating airflow velocity of 300 ft/minute for high-capacity type. Air filter pressure drop for non-standard filters must not exceed 0.08 in. wg.

NOTE: Pressure test the gas supply system *after* the gas supply piping is connected to the gas valve. The supply piping must be disconnected from the gas valve during the testing of the piping systems when test pressure is in excess of 0.5 psig. Pressure test the gas supply piping system at pressures equal to or less than 0.5 psig. The unit heating section must be isolated from the gas piping system by closing the external main manual shutoff valve and slightly opening the ground-joint union.

Table 2—Physical Data—Unit PY2P (Continued)

UNIT SIZE PY2P	048090	048115	048130	060090	060115	060130
NOMINAL CAPACITY (ton)	4	4	4	5	5	5
OPERATING WEIGHT (lb.)	421	421	421	468	468	468
COMPRESSORS Quantity	Scroll 1					
REFRIGERANT (R-22) Quantity (lb.)	8.3	8.3	8.3	8.1	8.1	8.1
REFRIGERANT METERING DEVICE Orifice ID (in.)	Acutrol Device					
	.034	.034	.034	.032	.032	.032
CONDENSER COIL Rows...Fins/in. Face Area (sq ft)	2...17 12.3	2...17 12.3	2...17 12.3	2...17 16.4	2...17 16.4	2...17 16.4
CONDENSER FAN Nominal Cfm Diameter (in.) Motor Hp (Rpm)	3300 22 ¼ (1100)	3300 22 ¼ (1100)	3300 22 ¼ (1100)	3300 22 ¼ (1100)	3300 22 ¼ (1100)	3300 22 ¼ (1100)
EVAPORATOR COIL Rows...Fins/in. Face Area (sq ft)	4...15 4.7	4...15 4.7	4...15 4.7	4...15 4.7	4...15 4.7	4...15 4.7
EVAPORATOR BLOWER Nominal Airflow (Cfm) Size (in.) Motor Hp (Rpm)	1600 11 X 10 ¾ (1075)	1600 11 X 10 ¾ (1075)	1600 11 X 10 ¾ (1075)	1750 11 X 10 1.0 (1075)	1750 11 X 10 1.0 (1075)	1750 11 X 10 1.0 (1075)
FURNACE SECTION* Burner Orifice No. (Qty...Drill Size) Natural Gas Burner Orifice No. (Qty...Drill Size) Propane Gas	3...38 3...46	3...33 3...42	3...31 3...41	3...38 3...46	3...33 3...42	3...31 3...41
RETURN-AIR FILTERS (in.)† Throwaway	24 X 30	24 X 30	24 X 30	24 X 30	24 X 30	24 X 30

* Based on altitude of 0 to 2000 ft.

† Required filter sizes shown are based on the larger of the ARI (Air Conditioning and Refrigeration Institute) rated cooling airflow or the heating airflow velocity of 300 ft/minute for high-capacity type. Air filter pressure drop for non-standard filters must not exceed 0.08 in. wg.

Table 3—Maximum Gas Flow Capacity*

NOMINAL IRON PIPE, SIZE (IN.)	INTERNAL DIAMETER (IN.)	LENGTH OF PIPE, FT†													
		10	20	30	40	50	60	70	80	90	100	125	150	175	200
½	.622	175	120	97	82	73	66	61	57	53	50	44	40	—	—
¾	.824	360	250	200	170	151	138	125	118	110	103	93	84	77	72
1	1.049	680	465	375	320	285	260	240	220	205	195	175	160	145	135
1¼	1.380	1400	950	770	600	580	530	490	460	430	400	360	325	300	280
1½	1.610	2100	1460	1180	990	900	810	750	690	650	620	550	500	460	430

* Capacity of pipe in cu ft of gas per hr for gas pressure of 0.5 psig or less. Pressure drop of 0.5-in. wg (based on a 0.60 specific gravity gas). Refer to Table C-4, National Fire Protection Association NFPA 54.

† This length includes an ordinary number of fittings.

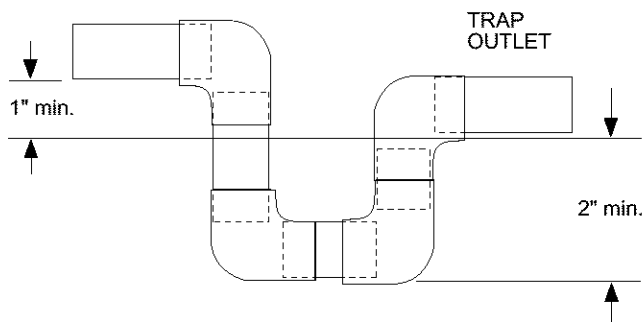
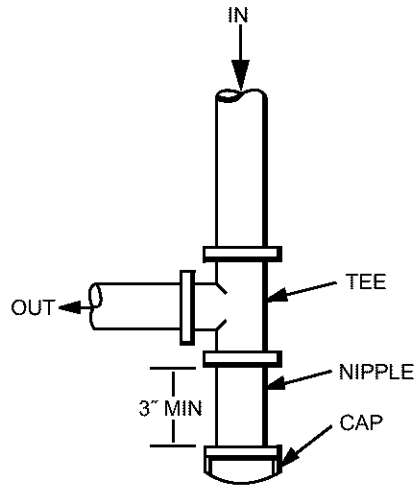

Fig. 8—Condensate Trap

C00009

⚠ CAUTION: Unstable operation may occur when the gas valve and manifold assembly are forced out of position while connecting improperly-routed rigid gas piping to the gas valve. Use a backup wrench when making connection to avoid strain on, or distortion of, the gas control piping.



C99020

Fig. 9—Sediment Trap

⚠ CAUTION: If a flexible conductor is required or allowed by the authority having jurisdiction, black iron pipe shall be installed at the gas valve and shall extend a minimum of 2 in. outside the unit casing.

⚠ WARNING: Never use a match or other open flame when checking for gas leaks. Never purge gas line into combustion chamber. Failure to follow this warning could result in an explosion causing serious injury or death.

8. Check for gas leaks at the field-installed and factory-installed gas lines after all piping connections have been completed. Use soap-and-water solution (or method specified by local codes and/or regulations).

PROCEDURE 9—INSTALL DUCT CONNECTIONS

The unit has duct flanges on the supply- and return-air openings on the side and bottom of the unit. For downshot applications, the ductwork connects to the roof curb (See Fig. 2 and 3 for connections sizes and locations).

A. CONFIGURING UNITS FOR DOWNFLOW (VERTICAL) DISCHARGE

⚠ WARNING: Before performing service or maintenance operations on the system, turn off main power to unit. Electrical shock could cause serious injury or death.

1. Open all electrical disconnects before starting any service work.
2. Remove return duct cover located on duct panel by breaking connecting tabs with screwdriver and a hammer (See Fig. 10A & 10B).

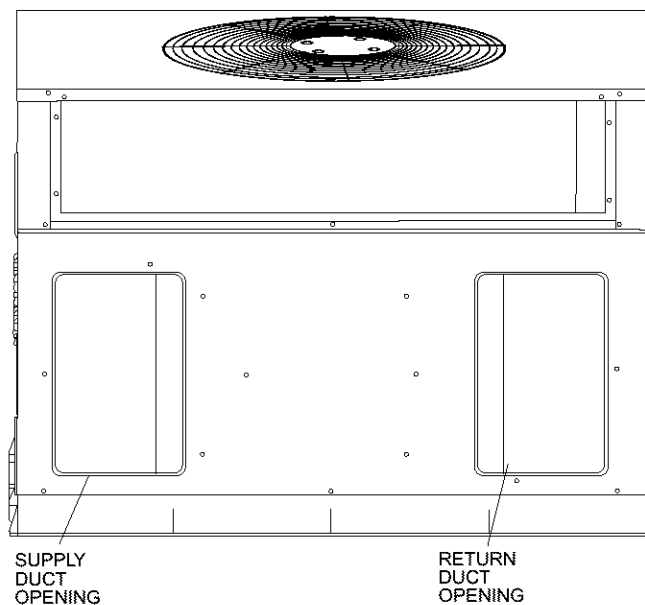

C99011

Fig. 10A Supply and Return Duct Opening

3. To remove supply duct cover, break front and right side connecting tabs with a screwdriver and a hammer. Push louver down to break rear and left side tabs (See Fig. 10A & 10B).

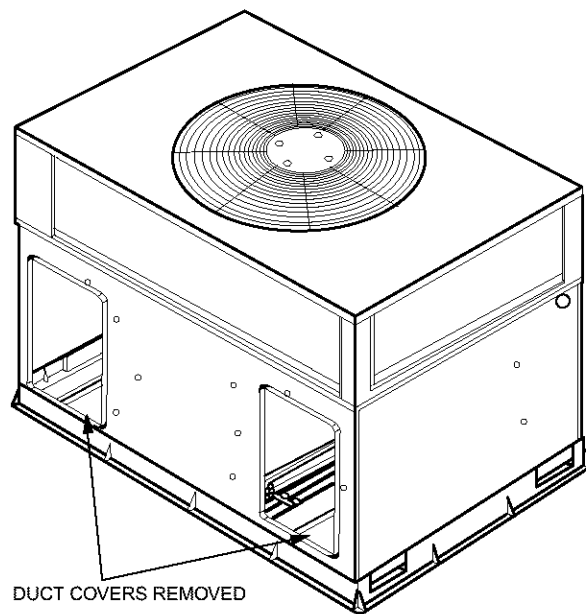

Fig. 10B—Vertical Duct Cover Removed

C99012

4. If unit ductwork is to be attached to vertical opening flanges on the unit composite base (jackstand applications only), do so at this time.

⚠ CAUTION: Collect ALL screws that were removed. Do not leave screws on rooftop as permanent damage to the roof may occur.

5. It is recommended that the unit base insulation around the perimeter of the vertical return-air opening be secured to the unit base with aluminum tape. Applicable local codes may require aluminum tape to prevent exposed fiberglass.
6. Cover both horizontal duct openings with the duct covers from the accessory duct cover kit. Ensure opening is air- and watertight.
7. After completing unit conversion, perform all safety checks and power up unit.

NOTE: The design and installation of the duct system must be in accordance with the standards of the NFPA for installation of nonresidence-type air conditioning and ventilating systems, NFPA 90A or residence-type, NFPA 90B; and/or local codes and ordinances.

Adhere to the following criteria when selecting, sizing, and installing the duct system:

1. Units are shipped for horizontal duct installation (by removing duct covers).
2. Select and size ductwork, supply-air registers, and return-air grilles according to American Society of Heating, Refrigeration and Air Conditioning Engineers (ASHRAE) recommendations.
3. Use flexible transition between rigid ductwork and unit to prevent transmission of vibration. The transition may be screwed or bolted to duct flanges. Use suitable gaskets to ensure weathertight and airtight seal.
4. All units must have field-supplied filters or accessory filter rack installed in the return-air side of the unit. Recommended sizes for filters are shown in Tables 1 and 2.
5. Size all ductwork for maximum required airflow (either heating or cooling) for unit being installed. Avoid abrupt duct size increases or decreases or performance may be affected.
6. Adequately insulate and weatherproof all ductwork located outdoors. Insulate ducts passing through unconditioned space, and use vapor barrier in accordance with latest issue of Sheet Metal and Air Conditioning Contractors National Association (SMACNA) and Air Conditioning Contractors of America (ACCA) minimum installation standards for heating and air conditioning systems. Secure all ducts to building structure.
7. Flash, weatherproof, and vibration-isolate all openings in building structure in accordance with local codes and good building practices.

PROCEDURE 10—INSTALL ELECTRICAL CONNECTIONS

⚠ WARNING: The unit cabinet must have an uninterrupted, unbroken electrical ground to minimize the possibility of serious injury if an electrical fault should occur. This ground may consist of an electrical wire connected to the unit ground lug in the control compartment, or conduit approved for electrical ground when installed in accordance with NEC (National Electrical Code) ANSI/NFPA (latest edition) and local electrical codes. In Canada, follow Canadian Electrical Code CSA (Canadian Standards Association) C22.1 and local electrical codes. Failure to adhere to this warning could result in serious injury or death.

⚠ CAUTION: Failure to follow these precautions could result in damage to the unit being installed:

1. Make all electrical connections in accordance with NEC ANSI/NFPA (latest edition) and local electrical codes governing such wiring. In Canada, all electrical connections must be in accordance with CSA standard C22.1 Canadian Electrical Code Part 1 and applicable local codes. Refer to unit wiring diagram.
2. Use only copper conductor for connections between field-supplied electrical disconnect switch and unit. DO NOT USE ALUMINUM WIRE.
3. Be sure that high-voltage power to unit is within operating voltage range indicated on unit rating plate.
4. Do not damage internal components when drilling through any panel to mount electrical hardware, conduit, etc. On 3-phase units, ensure phases are balanced within 2 percent. Consult local power company for correction of improper voltage and/or phase imbalance.

A. HIGH-VOLTAGE CONNECTIONS

The unit must have a separate electrical service with a field-supplied, waterproof, disconnect switch mounted at, or within sight from, the unit. Refer to the unit rating plate for maximum fuse/circuit breaker size and minimum circuit amps (ampacity) for wire sizing (See Tables 4 and 5 for electrical data).

The field-supplied disconnect switch box may be mounted on the unit over the high-voltage inlet hole when the standard power and low-voltage entry points are used (See Fig. 2 and 3 for acceptable location).

See unit wiring label and Fig. 11 for reference when making high voltage connections. Proceed as follows to complete the high-voltage connections to the unit.

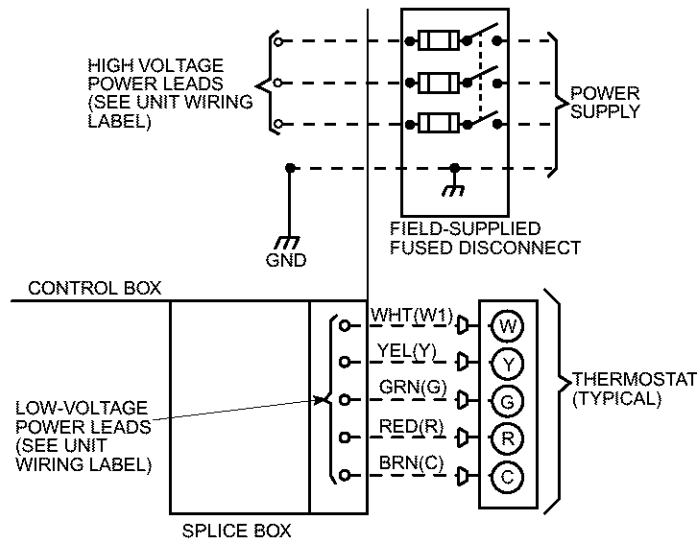

Fig. 11—High- and Control-Voltage Connections

Single phase units:

1. Run the high-voltage (L1, L2) and ground leads into the control box.
2. Connect ground lead to chassis ground connection.
3. Connect L1 to pressure lug connection 11 of the compressor contactor.
4. Connect L2 to pressure lug connection 23 of the compressor contactor.

Three-phase units:

1. Run the high-voltage (L1, L2, L3) and ground leads into the control box.
2. Connect ground lead to chassis ground connection.
3. Locate the black and yellow wires connected to the lines side of the contactor.
4. Connect field L1 to black wire on connection 11 of the compressor contactor.
5. Connect field wire L2 to yellow wire on connection 13 of the compressor contactor.

C99018

Table 4—Electrical Data—Unit PY1P

UNIT SIZE PY1P	V-PH-HZ	VOLTAGE RANGE		COMPRESSOR		OUTDOOR FAN MOTOR	INDOOR FAN MOTOR	POWER SUPPLY	
		Min	Max	RLA	LRA	FLA	FLA	MCA	Max Fuse or Ckt Bkr
018	208/230-1-60	187	253	9.0	45.0	0.8	1.8	13.9	20
024	208/230-1-60	187	253	12.8	61.0	0.8	2.0	18.8	30
030	208/230-1-60	187	253	14.4	73.0	0.8	2.0	20.8	30
	208/230-3-60	187	253	12.6	68.0	0.8	2.0	13.2	20
036	208/230-1-60	187	253	13.0	81.0	1.6	3.6	24.0	35
	208/230-3-60	187	253	9.0	78.0	1.6	3.6	16.5	25
	460-3-60	414	506	4.5	40.0	0.9	1.9	8.4	15
042	208/230-1-60	187	253	18.6	105.0	1.6	3.8	27.5	45
	208/230-3-60	187	253	10.7	85.0	1.6	3.8	18.8	25
	460-3-60	414	506	5.3	42.0	0.9	2.0	9.5	15
048	208/230-1-60	197	253	25.3	131.0	1.6	3.8	37.0	60
	208/230-3-60	187	253	13.5	108.0	1.6	3.8	22.3	35
	460-3-60	414	506	6.7	47.5	0.9	2.0	11.3	15
060	208/230-1-60	187	253	28.9	147.0	1.6	6.2	43.9	60
	208/230-3-60	187	253	18.6	125.0	1.6	6.2	31.1	45
	460-3-60	414	506	8.5	66.5	0.9	3.2	14.7	20

6. Connect field wire L3 to Blue wire from compressor.

B. SPECIAL PROCEDURES FOR 208-V OPERATION

⚠ WARNING: Before making any wiring changes, make sure the gas supply is switched off first. Then switch off the power supply to the unit and install lockout tag. Electrical shock can cause serious injury or death.

C. CONTROL VOLTAGE CONNECTIONS

Do not use any type of power-stealing thermostat. Unit control problems may result.

Use no. 18 American Wire Gage (AWG) color-coded, insulated (35 C minimum) wires to make the control voltage connections between the thermostat and the unit. If the thermostat is located more than 100 ft from the unit (as measured along the control voltage wires), use no. 16 AWG color-coded, insulated (35 C minimum) wires.

STANDARD CONNECTION

Remove knockout hole located in the flue panel adjacent to the control access panel (See Fig. 2 and 3). Remove the rubber grommet from the installer’s packet (included with unit) and install grommet in the knockout opening. Provide a drip loop before running wire through panel.

Run the low-voltage leads from the thermostat, through the inlet hole, and into unit low-voltage splice box.

Locate five 18-gage wires leaving control box. These low-voltage connection leads can be identified by the colors red, green, yellow, brown, and white (See Fig. 11). Ensure the leads are long enough to be routed into the low-voltage splice box (located below right side of control box). Route leads through hole in bottom of control box and make low-voltage connections (See Fig. 11). Secure all cut wires, so that they do not interfere with operation of unit.

D. HEAT ANTICIPATOR SETTING

The room thermostat heat anticipator must be properly adjusted to ensure proper heating performance. Set the heat anticipator, using an ammeter between the W and R terminals to determine the exact required setting.

NOTE: For thermostat selection purposes, use 0.18 amp for the approximate required setting. Failure to make a proper heat anticipator adjustment will result in improper operation, discomfort to the occupants of the conditioned space, and inefficient energy utilization; however, the required setting may be changed slightly to provide a greater degree of comfort for a particular installation.

E. TRANSFORMER PROTECTION

The transformer is of the energy-limiting type. It is set to withstand a 30-sec. overload or shorted secondary condition.

- LEGEND**
- FLA — Full Load Amps
 - LRA — Locked Rotor Amps
 - MCA — Minimum Circuit Amps
 - MOCP — Maximum Overcurrent Protection
 - RLA — Rated Load Amps
 - CKT BKR — Circuit Breaker



EXAMPLE: Supply voltage is 460-3-60.

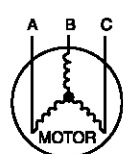

AB = 452 v
BC = 464 v
AC = 455 v

$$\begin{aligned} \text{Average Voltage} &= \frac{452 + 464 + 455}{3} \\ &= \frac{1371}{3} \\ &= 457 \end{aligned}$$

Determine maximum deviation from average voltage.

(AB) 457 452 = 5 v
(BC) 464 457 = 7 v
(AC) 457 455 = 2 v

Maximum deviation is 7 v.

Determine percent of voltage imbalance.

$$\begin{aligned} \% \text{ Voltage Imbalance} &= 100 \times \frac{7}{457} \\ &= 1.53\% \end{aligned}$$

This amount of phase imbalance is satisfactory as it is below the maximum allowable 2%.

IMPORTANT: If the supply voltage phase imbalance is more than 2%, contact your local electric utility company immediately.

C99024

Table 4—Legend

Table 5—Electrical Data—Unit PY2P

UNIT SIZE PY2P	V-PH-HZ	VOLTAGE RANGE		COMPRESSOR		OUTDOOR FAN MOTOR	INDOOR FAN MOTOR	POWER SUPPLY	
		Min	Max	RLA	LRA	FLA	FLA	MCA	Max Fuse or Ckt Bkr
024	208/230-1-60	187	253	10.9	54.0	0.9	2.0	15.7	25
030	208/230-1-60	187	253	13.5	73.0	0.8	2.1	19.8	30
	208/230-3-60	187	253	9.0	63.0	0.8	2.1	14.2	20
036	208/230-1-60	187	253	16.7	97.0	0.8	3.6	25.3	40
	208/230-3-60	187	253	11.2	75.0	0.8	3.6	18.4	25
	460-3-60	414	506	5.4	37.5	0.9	1.9	9.6	15
042	208/230-1-60	187	253	17.9	104.0	1.6	4.1	28.1	45
	208/230-3-60	187	253	12.4	88.0	1.6	4.1	21.2	30
	460-3-60	414	506	6.1	44.0	0.9	2.0	10.5	15
048	208/230-1-60	187	253	23.4	126.0	1.5	4.1	34.9	45
	208/230-3-60	187	253	13.0	93.0	1.5	4.1	21.9	30
	460-3-60	414	506	6.4	46.5	0.9	1.9	10.8	15
060	208/230-1-60	187	253	28.8	169.0	1.6	6.2	43.8	60
	208/230-3-60	187	253	17.3	123.0	1.6	6.2	29.4	45
	460-3-60	414	506	9.0	62.0	0.9	3.2	15.4	20

PRE-START-UP

- ⚠ WARNING:** Failure to observe the following warnings could result in serious injury:
1. Follow recognized safety practices and wear protective goggles when checking or servicing refrigerant system.
 2. Do not operate compressor or provide any electric power to unit unless compressor terminal cover is in place and secured.
 3. Do not remove compressor terminal cover until all electrical sources are disconnected.
 4. Relieve and recover all refrigerant from system before touching or disturbing anything inside terminal box if refrigerant leak is suspected around compressor terminals.
 5. Never attempt to repair soldered connection while refrigerant system is under pressure.
 6. Do not use torch to remove any component. System contains oil and refrigerant under pressure. To remove a component, wear protective goggles and proceed as follows:
 - a. Shut off gas supply and then electrical power to unit.
 - b. Relieve and recover all refrigerant from system using both high- and low-pressure ports.
 - c. Cut component connecting tubing with tubing cutter and remove component from unit.
 - d. Carefully unsweat remaining tubing stubs when necessary. Oil can ignite when exposed to torch flame.

Proceed as follows to inspect and prepare the unit for initial startup:

1. Remove access panel.
2. Read and follow instructions on all WARNING, CAUTION, and INFORMATION labels attached to, or shipped with, unit.

- LEGEND
- FLA — Full Load Amps
 - LRA — Locked Rotor Amps
 - MCA — Minimum Circuit Amps
 - MOCP — Maximum Overcurrent Protection
 - RLA — Rated Load Amps
 - CKT BKR — Circuit Breaker



EXAMPLE: Supply voltage is 460-3-60.

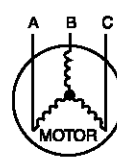

AB = 452 v
BC = 464 v
AC = 455 v

$$\begin{aligned} \text{Average Voltage} &= \frac{452 + 464 + 455}{3} \\ &= \frac{1371}{3} \\ &= 457 \end{aligned}$$

Determine maximum deviation from average voltage.

(AB) 457 452 = 5 v
(BC) 464 457 = 7 v
(AC) 457 455 = 2 v

Maximum deviation is 7 v.

Determine percent of voltage imbalance.

$$\begin{aligned} \% \text{ Voltage Imbalance} &= 100 \times \frac{7}{457} \\ &= 1.53\% \end{aligned}$$

This amount of phase imbalance is satisfactory as it is below the maximum allowable 2%.

IMPORTANT: If the supply voltage phase imbalance is more than 2%, contact your local electric utility company immediately.

C99024

Table 5—Legend

3. Make the following inspections:
 - a. Inspect for shipping and handling damages such as broken lines, loose parts, disconnected wires, etc.
 - b. Inspect for oil at all refrigerant tubing connections and on unit base. Detecting oil generally indicates a refrigerant leak.
 - c. Leak test all refrigerant tubing connections using electronic leak detector, halide torch, or liquid-soap solution. If a refrigerant leak is detected, see the *Check for Refrigerant Leaks* section.
 - d. Inspect all field- and factory-wiring connections. Be sure that connections are completed and tight.
 - e. Ensure wires do not contact refrigerant tubing or sharp sheet metal edges.
 - f. Inspect coil fins. If damaged during shipping and handling, carefully straighten fins with a fin comb.
4. Verify the following conditions:

⚠ CAUTION: Do not purge gas supply into the combustion chamber. Do not use a match or other open flame to check for gas leaks. Failure to follow this warning could result in an explosion causing serious injury or death.

- a. Make sure gas line is free of air. Before lighting the unit for the first time, perform the following with the gas valve in the “OFF” position: If the gas supply pipe was not purged before connecting the unit, it will be full of air. It is recommended that the ground joint union be loosened, and the supply line be allowed to purge until the odor of gas is detected. Never purge gas lines into a combustion chamber. Immediately upon detection of gas odor, retighten the union. Allow 5 minutes to elapse, then light unit.
- b. Make sure that condenser-fan blade is correctly positioned in fan orifice. Leading edge of condenser-fan blade should be 1/2 in. maximum from fan orifice venturi.
- c. Ensure fan hub is 1/8 in. maximum from motor housing (See Fig. 12).

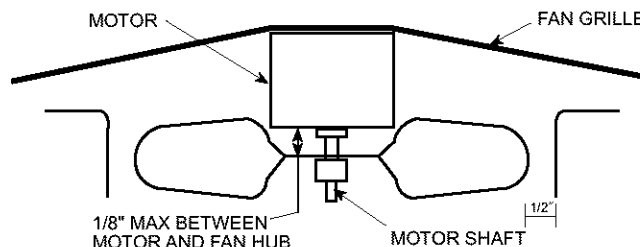

Fig. 12—Fan Blade Clearance

C99009

- d. Make sure that air filter(s) is in place.
- e. Make sure that condensate drain trap is filled with water to ensure proper drainage.
- f. Make sure that all tools and miscellaneous loose parts have been removed.

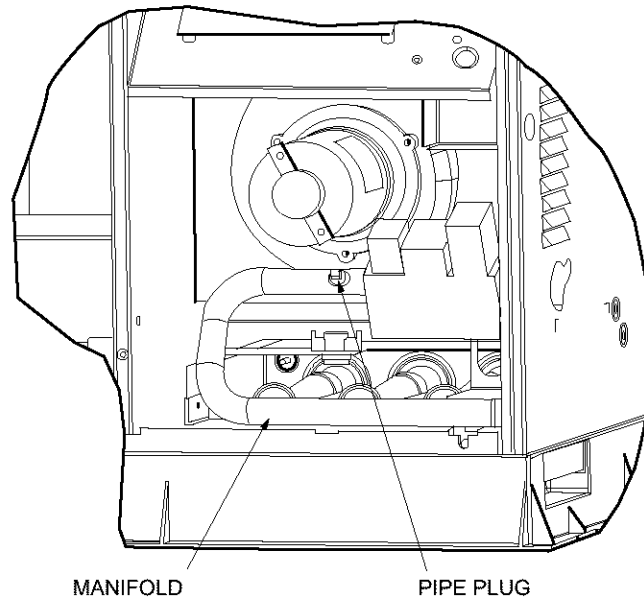

Fig. 13—Burner Assembly

C99019

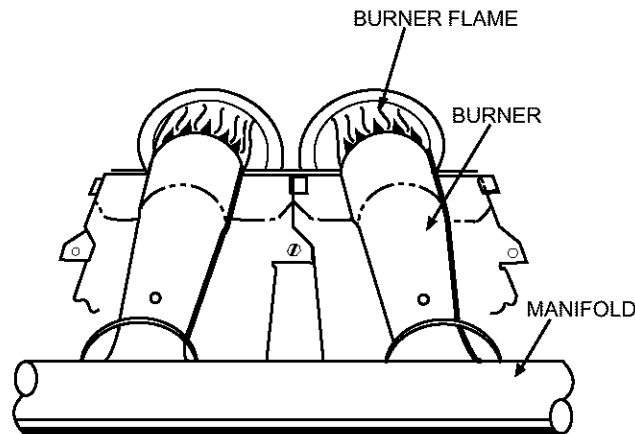

Fig. 14—Monoport Burner
START-UP

C99021

PROCEDURE 1—CHECK FOR REFRIGERANT LEAKS

Proceed as follows to locate and repair a refrigerant leak and to charge the unit:

1. Locate leak and make sure that refrigerant system pressure has been relieved and reclaimed from both high- and low-pressure ports.
2. Repair leak following Refrigerant Service procedures.

NOTE: Install a filter drier whenever the system has been opened for repair.

3. Add a small charge of R-22 refrigerant vapor to system and leak-test unit.
4. Recover refrigerant from refrigerant system and evacuate to 500 microns if additional leaks are not found.
5. Charge unit with R-22 refrigerant, using a volumetric-charging cylinder or accurate scale. *Refer to unit rating plate for required charge.* Be sure to add extra refrigerant to compensate for internal volume of filter drier.

PROCEDURE 2—START-UP HEATING AND MAKE ADJUSTMENTS

⚠ CAUTION: Complete the required procedures given in the *Pre-Start-Up* section before starting the unit.

Do not jumper any safety devices when operating the unit.

Make sure that burner orifices are properly aligned. Unstable operation may occur when the burner orifices in the manifold are misaligned. Follow the lighting instructions on the heating section operation label (located inside the burner or blower access door) to start the heating section.

NOTE: Make sure that gas supply has been purged, and that all gas piping has been checked for leaks.

A. CHECK HEATING CONTROL

Start and check the unit for proper heating control operation as follows (see furnace lighting instructions located inside burner or blower access panel):

1. Place room thermostat SYSTEM switch in the HEAT position and the fan switch is placed in AUTO. position.

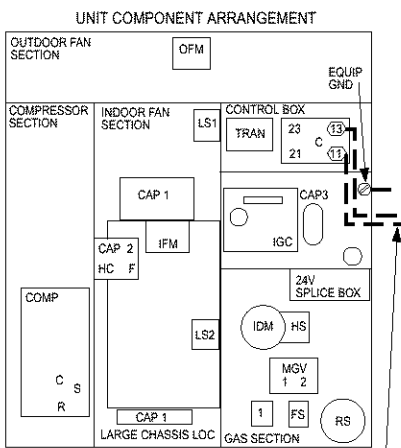
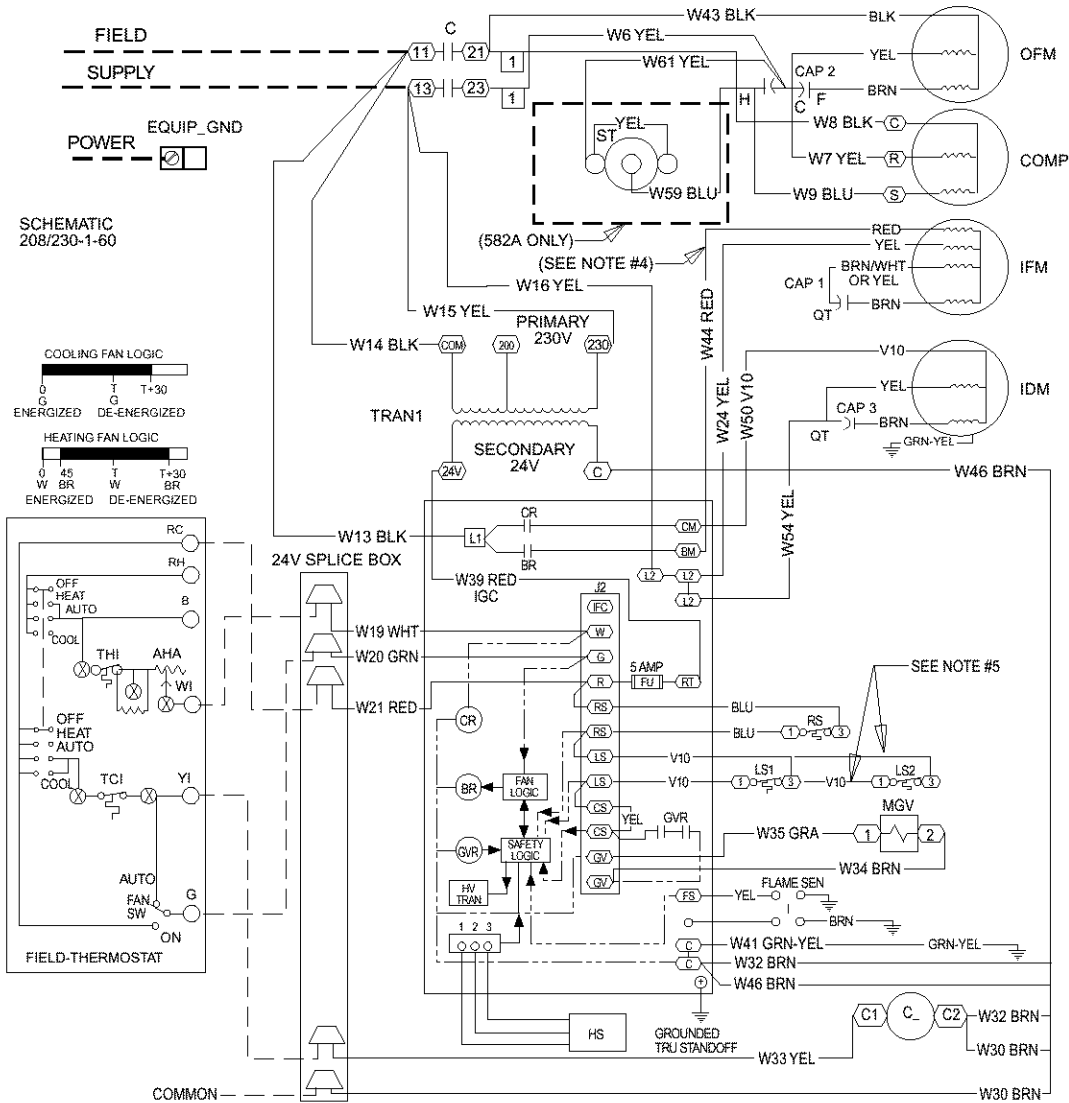

- AHA - Adjustable Heat Anticipator
 BR - Blower Relay
 C - Contactor
 CAP - Capacitor
 COMP - Compressor Motor
 CR - Combustion Relay
 CS - Centrifugal Switch
 EQUIP - Equipment
 FS - Flame Sensor
 FU - Fuse
 GND - Ground
 GV - Gas Valve
 GVR - Gas Valve Relay
 HS - Hall Effect Sensor
 HV - High Voltage
 TRAN - Transformer
 I - Ignitor
 IDM - Induced-Draft Motor
 IFC - Indoor-Fan Contactor
 IFM - Indoor-Fan Motor
 IGC - Integrated Gas Unit Controller
 L1 - Line
 LS - Limit Switch
 LS1 - Limit Switch
 MGV - Main Gas Valve

- DISCONNECT PER NEC
LEGEND
 NEC - National Electrical Code
 OFM - Outdoor-Fan Motor
 QT - Quadruple Terminal
 RS - Rollout Switch
 SEN - Sensor
 SW - Switch
 TRAN - Transformer
 Field Splice
 Terminal (Marked)
 Terminal (Unmarked)
 Splice
 Splice (Marked)
 Factory Wiring
 Field Control Wiring
 Field Power Wiring
 Accessory or Optional Wiring
 To Indicate Common Potential Only, Not to Represent Wiring

- NOTES:**
 1. If any of the original wires furnished are replaced, they must be replaced with type 90 degree C wire or its equivalent.
 2. See price pages for thermostat and subbases.
 3. Use 75 degree C copper conductors for field installation.
 4. For high speed IFM, disconnect RED wire from IGC terminal BM and connect BLK wire from IFM. For medium speed, disconnect RED wire from IGC terminal BM and connect BLU wire from IFM.

Fig. 15—208/230-1-60 Wiring Diagram, Units PY1P and PY2P

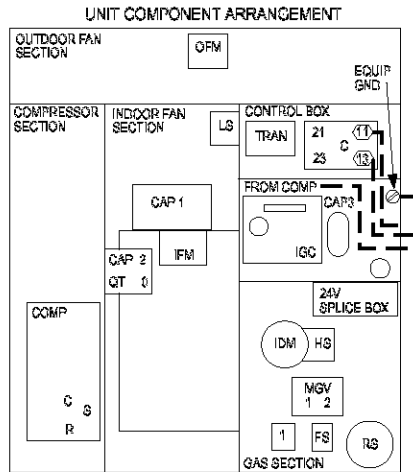
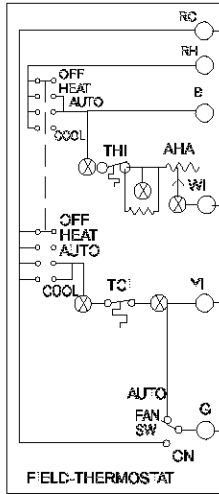
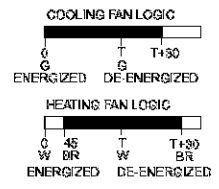
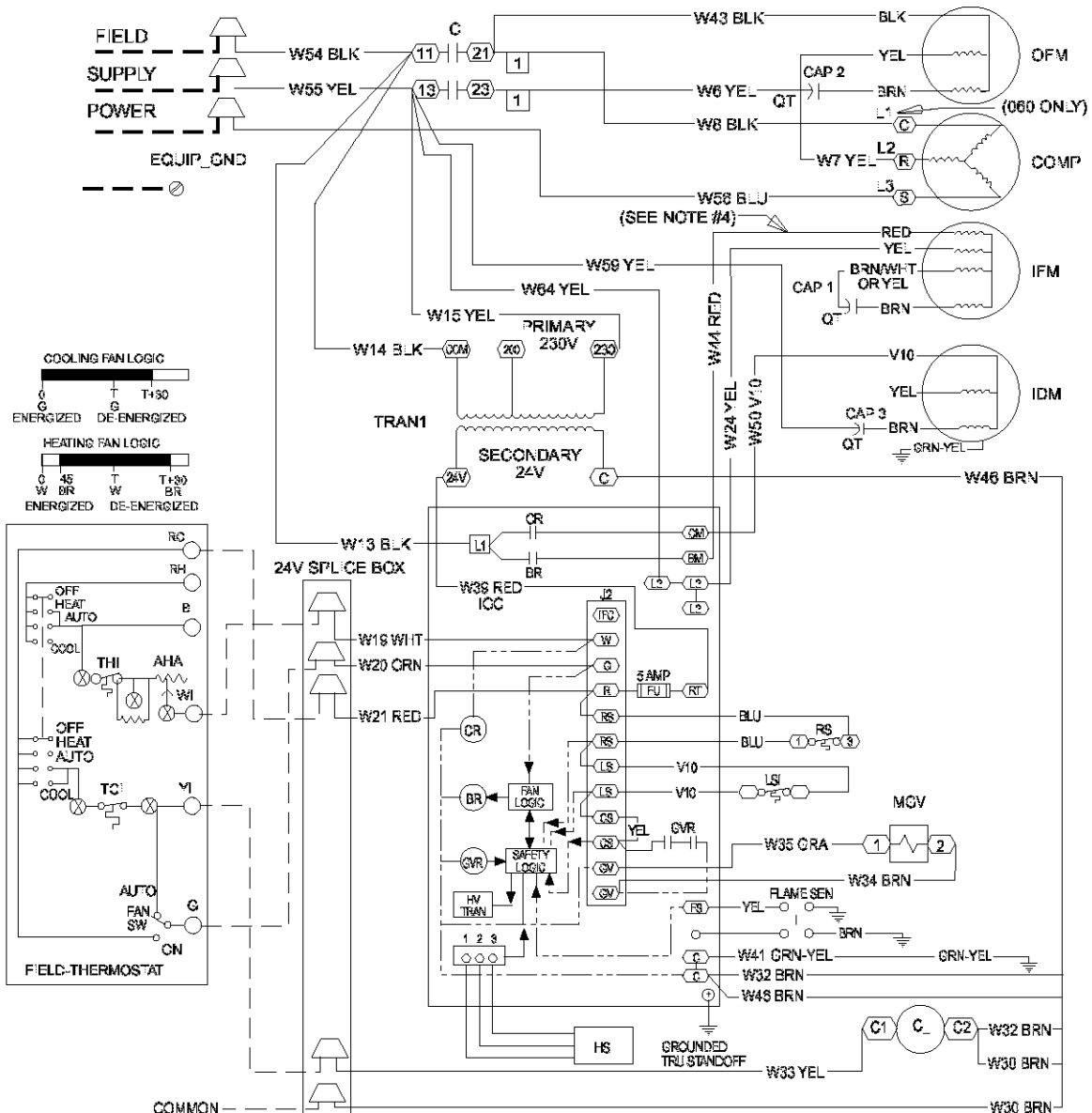

- LEGEND**
- NEC - National Electrical Code
 - OFM - Outdoor-Fan Motor
 - QT - Quadripole Terminal
 - RS - Rollout Switch
 - SEN - Sensor
 - SW - Switch
 - TRAN - Transformer
 - Field Splice
 - Terminal (Marked)
 - Terminal (Unmarked)
 - Splice
 - Splice (Marked)
 - Factory Wiring
 - Field Control Wiring
 - Field Power Wiring
 - Accessory or Optional Wiring
 - To indicate Common Potential Only, Not to Represent Wiring

- AHA - Adjustable Heat Anticaster
- BR - Blower Relay
- C - Contactor
- CAP - Capacitor
- COMP - Compressor Motor
- CR - Combustion Relay
- CS - Centrifugal Switch
- EQUIP - Equipment
- FS - Flame Sensor
- FU - Fuse
- GND - Ground
- GV - Gas Valve
- GVR - Gas Valve Relay
- HS - Hall Effect Sensor
- HV - High Voltage
- TRAN - Transformer
- I - Ignitor
- IDM - Induced-Draft Motor
- IFC - Indoor-Fan Contactor
- IFM - Indoor-Fan Motor
- IGC - Integrated Gas Unit Controller
- L1 - Line
- LS - Limit Switch
- LS* - Limit Switch
- MGV - Main Gas Valve

- NOTES:**
1. If any of the original wires furnished are replaced, they must be replaced with type 90 degree C wire or its equivalent.
 2. See price pages for thermostat and subbases.
 3. Use 75 degree C copper conductors for field installation.
 4. For high speed IFM, disconnect RED wire from IGC terminal BM and connect BLK wire from IFM. For medium speed, disconnect RED wire from IGC terminal BV and connect BLU wire from IFV.

C00058

Fig. 16—208/230-3-60 Wiring Diagram, Units PY1P and PY2P

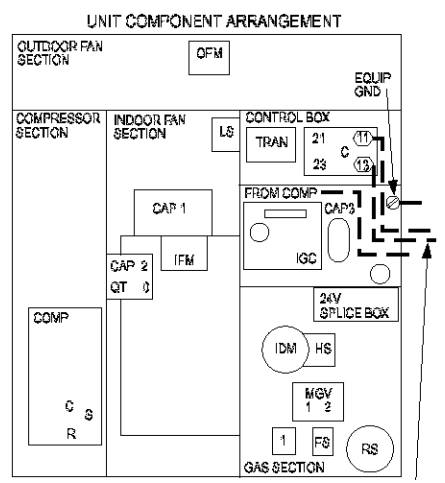
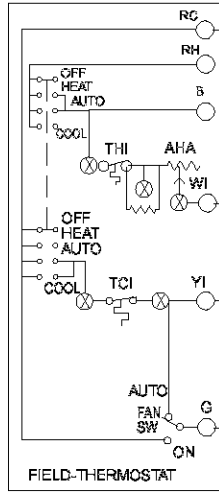
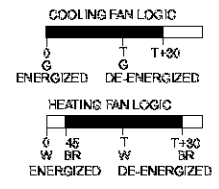
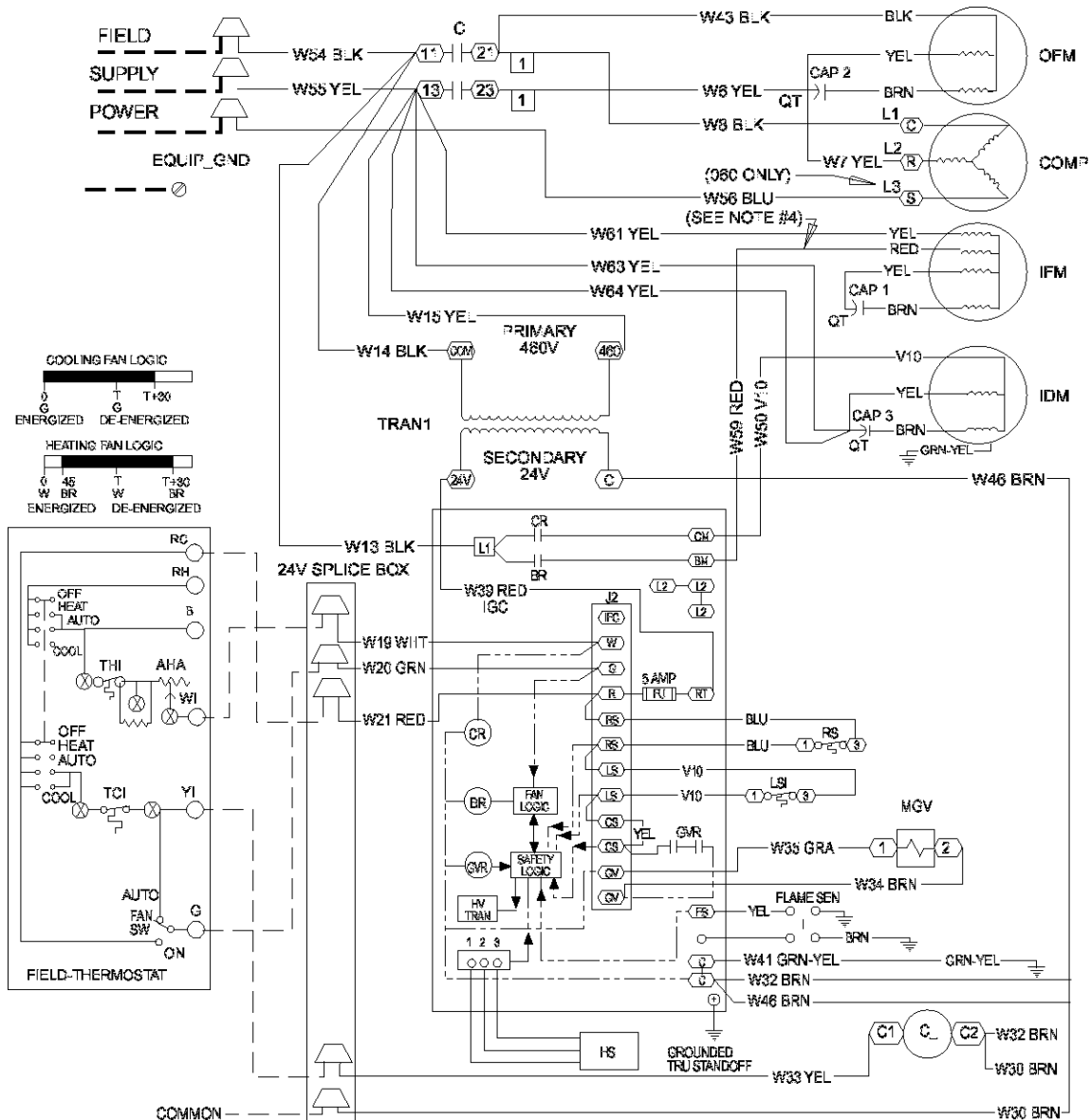

- LEGEND**
- AHA - Adjustable Heat Anticipator
 - BR - Blower Relay
 - C - Contactor
 - CAP - Capacitor
 - COMP - Compressor Motor
 - CR - Combustion Relay
 - CS - Centrifugal Switch
 - EQUIP - Equipment
 - FS - Flame Sensor
 - FU - Fuse
 - GND - Ground
 - GV - Gas Valve
 - GVR - Gas Valve Relay
 - HS - Half Effect Sensor
 - HV - High Voltage
 - TRAN - Transformer
 - IDM - Induced-Draft Motor
 - IFC - Indoor-Fan Contactor
 - IFM - Indoor-Fan Motor
 - IGC - Integrated Gas Unit Controller
 - L1 - Line
 - LS - Limit Switch
 - LS1 - Limit Switch
 - MGV - Main Gas Valve
 - NEC - National Electrical Code
 - OFM - Outdoor-Fan Motor
 - QT - Quadruple Terminal
 - RS - Rollout Switch
 - SEN - Sensor
 - SW - Switch
 - TRAN - Transformer
 - Field Splice
 - Terminal (Marked)
 - Terminal (Un-marked)
 - Splice
 - Splice (Marked)
 - Factory Wiring
 - Field Control Wiring
 - Field Power Wiring
 - Accessory or Optional Wiring
 - To Indicate Common Potential Only, Not to Represent Wiring

- NOTES:**
1. If any of the original wires furnished are replaced, they must be replaced with type 90 degree C wire or its equivalent.
 2. See price pages for thermostat and subbases.
 3. Use 75 degree C copper conductors for field installation.
 4. For high speed IFM, disconnect RED wire from IGC terminal BV and connect BLK wire from IFM. For medium speed, disconnect RED wire from IGC terminal BM and connect BLU wire from IFM.

Fig. 17—460-3-60 Wiring Diagram, Units PY1P and PY2P

Table 6—Heating Inputs

HEATING INPUT (BTUH)*	NUMBER OF ORIFICES	GAS SUPPLY PRESSURE (IN. WG)				MANIFOLD PRESSURE (IN. WG)	
		Natural		Propane†		Natural	Propane†
		Min	Max	Min	Max		
40,000	2	4.0	13.0	4.0	13.0	3.5	3.5
60,000	2	4.0	13.0	4.0	13.0	3.5	3.5
90,000	3	4.0	13.0	4.0	13.0	3.5	3.4
115,000	3	4.0	13.0	4.0	13.0	3.5	3.7
130,000	3	4.0	13.0	4.0	13.0	3.5	3.5

* When a unit is converted to propane, different size orifices must be used. See separate, natural-to-propane conversion kit instructions.

† Based on altitudes from sea level to 2000 ft above sea level. For altitudes above 2000 ft, reduce input rating 4 percent for each additional 1000 ft above sea level. In Canada, from 2000 ft above sea level to 4500 ft above sea level, derate the unit 10 percent.

- Set the heating temperature control of the thermostat above room temperature.
- The induced-draft motor will start.
- After a call for heating, the main burner should light within 5 sec. If the burners do not light, there is a 22-sec. delay before another 5-sec. try. If the burners still do not light, this sequence is repeated. If the burners do not light within 15 minutes from the initial call for heat, there is a lockout. To reset the control, break the 24-v power to W.
- The evaporator fan will turn on 45 sec. after the flame has been established. The evaporator fan will turn off 45 sec. after the thermostat has been satisfied.

B. CHECK GAS INPUT

Check gas input and manifold pressure after unit start-up (See Table 6). If adjustment is required proceed as follows:

- The rated gas inputs shown in Table 6 are for altitudes from sea level to 2000 ft above sea level. These inputs are based on natural gas with a heating value of 1050 Btu/ft³ at 0.65 specific gravity, or propane gas with a heating value of 2500 Btu/ft³ at 1.5 specific gravity.
- For elevations above 2000 ft, reduce input 4 percent for each 1000 ft above sea level.
- When the gas supply being used has a different heating value or specific gravity, refer to national and local codes, or contact your distributor to determine the required orifice size.

⚠ CAUTION: These units are designed to consume the rated gas inputs using the fixed orifices at specified manifold pressures as shown in Table 6. DO NOT REDRILL THE ORIFICES UNDER ANY CIRCUMSTANCES.

C. ADJUST GAS INPUT

The gas input to the unit is determined by measuring the gas flow at the meter or by measuring the manifold pressure. Measuring the gas flow at the meter is recommended for natural gas units. The manifold pressure must be measured to determine the input of propane gas units.

MEASURE GAS FLOW (NATURAL GAS UNITS)

Minor adjustment to the gas flow can be made by changing the manifold pressure. The manifold pressure must be maintained between 3.4 and 3.6 in. wg. If larger adjustments are required, change main burner orifices following the recommendations of national and local codes.

NOTE: All other appliances that use the same meter must be turned off when gas flow is measured at the meter.

Proceed as follows:

- Turn off gas supply to unit.
- Remove pipe plug on manifold (See Fig. 13) and connect manometer. Turn on gas supply to unit.
- Record number of seconds for gas meter test dial to make one revolution.
- Divide number of seconds in Step 3 into 3600 (number of seconds in one hour).
- Multiply result of Step 4 by the number of cu ft shown for one revolution of test dial to obtain cu ft of gas flow per hour.
- Multiply result of Step 5 by Btu heating value of gas to obtain total measured input in Btuh. Compare this value with heating input shown in Table 6 (Consult the local gas supplier if the heating value of gas is not known).

EXAMPLE: Assume that the size of test dial is 1 cu ft, one revolution takes 32 sec., and the heating value of the gas is 1050 Btu/ft³. Proceed as follows:

- 32 sec. to complete one revolution.
- $3600 \div 32 = 112.5$.
- $112.5 \times 1 = 112.5 \text{ ft}^3$ of gas flow/hr.
- $112.5 \times 1050 = 118,125 \text{ Btuh input}$.

If the desired gas input is 115,000 Btuh, only a minor change in the manifold pressure is required.

Observe manifold pressure and proceed as follows to adjust gas input:

Table 7—Air Delivery (Cfm) at Indicated Temperature Rise and Rated Heating Input

HEATING INPUT (BTUH)	TEMPERATURE RISE °F										
	20	25	30	35	40	45	50	55	60	65	70
40,000	1500	1200	1000	857	750	667	600	545	500	—	—
60,000	2250	1800	1500	1288	1125	1000	900	818	750	692	—
90,000	—	—	2250	1929	1688	1500	1350	1227	1125	1038	964
115,000	—	—	—	2464	2156	1917	1725	1568	1438	1327	1232
130,000	—	—	—	2786	2438	2167	1950	1773	1625	1500	—

NOTE: Dashed areas do not fall within the approved temperature rise range of the unit.

1. Remove cover screw over regulator adjustment screw on gas valve.
2. Turn regulator adjustment screw clockwise to increase gas input, or turn regulator adjustment screw counterclockwise to decrease input. Manifold pressure must be between 3.4 and 3.6 in. wg. Unsafe operation of the unit may result if manifold pressure is outside this range. Personal injury or unit damage may result.

⚠ WARNING: Unsafe operation of the unit may result if manifold pressure is outside this range. Serious injury , death or unit damage may result.

3. Replace cover screw cap on gas valve.
4. Turn off gas supply to unit. Remove manometer from pressure tap and replace pipe plug on gas valve. Turn on gas to unit and check for leaks.

MEASURE MANIFOLD PRESSURE (PROPANE UNITS)

The main burner orifices on a propane gas unit are sized for the unit rated input when the manifold pressure reading matches the level specified in Table 6.

Proceed as follows to adjust gas input on a propane gas unit:

1. Turn off gas to unit.
2. Remove pipe plug on manifold and connect manometer (See Fig. 13).
3. Turn on gas to unit.
4. Remove cover screw over regulator adjustment screw on gas valve.
5. Adjust regulator adjustment screw to the correct manifold pressure, as specified in Table 6. Turn adjusting screw clockwise to increase manifold pressure, or turn adjusting screw counterclockwise to decrease manifold pressure.
6. Replace cover screw.
7. Turn off gas to unit. Remove manometer from pressure tap. Replace pipe plug on gas valve, then turn on gas to unit. Check for leaks.

D. CHECK BURNER FLAME

With burner access panel removed, observe the unit heating operation. Watch the burner flames to see if they are light blue and soft in appearance, and that the flames are approximately the same for each burner. Propane will have blue flame with yellow tips (See Fig. 14). Refer to the *Maintenance* section for information on burner removal.

E. AIRFLOW AND TEMPERATURE RISE

The heating section for each size unit is designed and approved for heating operation within the temperature-rise range stamped on the unit rating plate.

Table 7 shows the approved temperature rise range for each heating input, and the air delivery cfm at various temperature rises. The heating operation airflow must produce a temperature rise that falls within the approved range.

Refer to *Indoor Airflow and Airflow Adjustments* section to adjust heating airflow when required.

F. HEATING SEQUENCE OF OPERATION

(See Fig. 15-17 and unit wiring label).

On a call for heating, terminal “W” of the thermostat is energized, starting the induced-draft motor. When the hall-effect sensor on the induced-draft motor senses that it has reached the required speed, the burner sequence begins. This function is performed by the integrated gas control (IGC). The evaporator-fan motor is energized 45 sec. after flame is established. When the thermostat is satisfied and “W” is deenergized, the burners stop firing and the evaporator-fan motor shuts off after a 45-sec. time-off delay.

An LED (light-emitting diode) indicator is provided on the control board to monitor operation. The control board is located by removing the burner access panel. During normal operation, the LED is continuously on (See Table 8 for error codes).

G. LIMIT SWITCHES

Normally closed limit switch (LS) completes the control circuit through the thermostat R circuit. Should the leaving-air temperature rise above the maximum allowable temperature, the limit switch opens and the R control circuit “breaks.” Any interruption in the R control circuit instantly closes the gas valve and stops gas flow to the burners and pilot. The blower motor continues to run until LS resets.

When the air temperature at the limit switch drops to the low-temperature setting of the limit switch, the switch closes and completes the R control circuit. The electric-spark ignition system cycles and the unit returns to normal heating operation.

Table 8—LED Indications

ERROR CODE	LED INDICATION
Normal Operation	On
Hardware Failure	Off
Fan On/Off Delay Modified	1 Flash
Limit Switch Fault	2 Flashes
Flame Sense Fault	3 Flashes
Four Consecutive Limit Switch Faults	4 Flashes
Ignition Lockout Fault	5 Flashes
Induced-Draft Motor Fault	6 Flashes
Rollout Switch Fault	7 Flashes
Internal Control Fault	8 Flashes
Temporary lock-out (1 hr)	9 Flashes

NOTES:

1. There is a 3-sec. pause between error code displays.
2. If more than one error code exists, all applicable error codes will be displayed in numerical sequence
3. This chart is on the wiring diagram located inside the burner access panel.

H. AUXILIARY LIMIT SWITCH (ROLLOUT)

The function of the switch is to close the main gas valve in the event of flame rollout. The switch is located above the main burners. When the temperature at the auxiliary switch reaches the maximum allowable temperature, the R control circuit trips, closing the gas valve and stopping gas flow to the burners. The indoor (evaporator) fan motor (IFM) and induced draft motor continue to run until switch is reset. The IGC LED will display FAULT CODE 7.

PROCEDURE 3—START-UP COOLING AND MAKE ADJUSTMENTS

⚠ CAUTION: Complete the required procedures given in the *Pre-Start-Up* section before starting the unit. Do not jumper any safety devices when operating the unit. Do not operate the compressor when the outdoor temperature is below 40°F (unless accessory low-ambient kit is installed). Do not rapid-cycle the compressor. Allow 5 minutes between “on” cycles to prevent compressor damage.

A. CHECKING COOLING CONTROL OPERATION

Start and check the unit for proper cooling control operation as follows:

1. Place room thermostat SYSTEM switch in OFF position. Observe that blower motor starts when FAN switch is placed in ON position and shuts down when FAN switch is placed in AUTO. position.
2. Place SYSTEM switch in COOL position and FAN switch in AUTO. position. Set cooling control below room temperature. Observe that compressor, condenser fan, and evaporator blower motors start. Observe that cooling cycle shuts down when control setting is satisfied. The evaporator fan will continue to run for 30 sec.
3. When using an auto-changeover room thermostat, place both SYSTEM and FAN switches in AUTO. positions. Observe that unit operates in Heating mode when temperature control is set to “call for heating” (above room temperature) and operates in Cooling mode when temperature control is set to “call for cooling” (below room temperature).

IMPORTANT: Three-phase, scroll compressor units (PY1P048 and PY2P030-060) are direction-oriented. These units must be checked to ensure proper compressor 3-phase power lead orientation. If not corrected within 5 minutes, the internal protector shuts off the compressor. The 3-phase power leads to the unit must be reversed to correct rotation. When turning backwards, scroll compressors emit elevated noise levels, and the difference between compressor suction and discharge pressures may be dramatically lower than normal.

B. CHECKING AND ADJUSTING REFRIGERANT CHARGE

The refrigerant system is fully charged with R-22 refrigerant, tested, and factory-scaled.

NOTE: Adjustment of the refrigerant charge is not required unless the unit is suspected of **not** having the proper R-22 charge.

A superheat charging chart is attached to the outside of the service access panel. The chart includes the required suction line temperature at given suction line pressures and outdoor ambient temperatures.

An accurate superheat, thermocouple- or thermistor-type thermometer, a sling psychrometer, and a gauge manifold are required when using the superheat charging method for evaluating the unit charge. *Do not use mercury or small dial-type thermometers because they are not adequate for this type of measurement.*

⚠ CAUTION: When evaluating the refrigerant charge, an indicated adjustment to the specified factory charge must always be very minimal. If a substantial adjustment is indicated, an abnormal condition exists somewhere in the cooling system, such as insufficient airflow across either coil or both coils.

Proceed as follows:

1. Remove caps from low- and high-pressure service fittings.
2. Using hoses with valve core depressors, attach low- and high-pressure gauge hoses to low- and high-pressure service fittings, respectively.

3. Start unit in Cooling mode and let unit run until system pressures stabilize.
4. Measure and record the following:
 - a. Outdoor ambient-air temperature (°F db).
 - b. Evaporator inlet-air temperature (°F wb).
 - c. Suction-tube temperature (°F) at low-side service fitting.
 - d. Suction (low-side) pressure (psig).
5. Using "Cooling Charging Charts," compare outdoor-air temperature (°F db) with the suction line pressure (psig) to determine desired system operating suction line temperature (See Fig. 18-30).
6. Compare actual suction-tube temperature with desired suction-tube temperature. Using a tolerance of $\pm 3^{\circ}\text{F}$, add refrigerant if actual temperature is more than 3°F higher than proper suction-tube temperature, or remove refrigerant if actual temperature is more than 3°F lower than required suction-tube temperature.

NOTE: If the problem causing the inaccurate readings is a refrigerant leak, refer to the *Check for Refrigerant Leaks* section.

C. INDOOR AIRFLOW AND AIRFLOW ADJUSTMENTS

⚠ CAUTION: For cooling operation, the recommended airflow is 350 to 450 cfm for each 12,000 Btuh of rated cooling capacity. For heating operation, the airflow must produce a temperature rise that falls within the range stamped on the unit rating plate.

Table 7 shows the temperature rise at various airflow rates. Tables 11 and 13 show both heating and cooling airflows at various external static pressures. Refer to these tables to determine the airflow for the system being installed (See Tables 14 and 15 for wet coil pressure drop).

NOTE: Be sure that all supply- and return-air grilles are open, free from obstructions, and adjusted properly.

⚠ WARNING: Before changing blower speed, shut off gas supply. Then disconnect electrical power to the unit and install lockout tag. Electrical shock or explosion can cause serious injury or death.

Airflow can be changed by changing the lead connections of the blower motor.

Unit PY1P two- or three-speed motors (except size 030) are factory wired for low speed operation. Unit PY1P030 is factory wired for medium speed.

All PY2P units are factory wired for low speed and may need to be wired for medium or high speed in the field.

FOR 208/230V

For color coding on the 208/230V motor leads, see Table 9.

Table 9—Color Coding for 208/230-V Motor Leads

3-SPEED	2-SPEED
black = high speed	black = high speed
blue = medium speed	—
red = low speed	red = low speed

To change the speed of the blower motor (BM), remove the fan motor speed leg lead from the blower relay (BR). This wire is attached to terminal BM of the integrated gas control (IGC) board for single- and 3-phase units. To change the speed, remove and replace with lead for desired blower motor speed. *Insulate the removed lead to avoid contact with chassis parts.*

FOR 460-V GE MOTORS

For color coding on the 460-v GE motor leads, see Table 10.

Table 10—Color Coding for 460-V GE Motor Leads

3-SPEED	2-SPEED
black = high speed	black = high speed
violet = jumper	blue = jumper
orange = medium speed	—
red = low speed	red = low speed

To change the speed of the blower motor (BM), remove fan motor speed lead from the blower relay (BR) and replace with the lead for the desired blower motor speed. The motor speed lead is attached to terminal BM of the integrated gas control (IGC) board. For low and medium speeds, black must be connected to the jumper wire. *Insulate removed lead end to avoid contact with chassis parts.* To select high speed on 460-v GE motors, separate the black (female quick connect – QC – from the jumper lead (male quick connect – QC) and connect the black lead to the BR. *Insulate the jumper to avoid contact with any chassis parts.*

D. COOLING SEQUENCE OF OPERATION

With the room thermostat SYSTEM switch in the COOL position and the FAN switch in the AUTO. position, the cooling sequence of operation is as follows:

1. When the room temperature rises to a point that is slightly above the cooling control setting of the thermostat, the thermostat completes the circuit between thermostat terminal R to terminals Y and G. These completed circuits through the thermostat:
2. The normally open contacts of energized contactor (C) close and complete the circuit through compressor motor (COMP) to condenser (outdoor) fan motor (OFM). Both motors start instantly.
3. The set of normally open contacts of energized relay BM close and complete the circuit through evaporator blower (indoor) fan motor (IFM).

NOTE: Once the compressor has started and then stopped, it **should not** be started again until 5 minutes have elapsed. The cooling cycle remains “on” until the room temperature drops to a point that is slightly below the cooling control setting of the room thermostat. At this point, the thermostat “breaks” the circuit between thermostat terminal R to terminals Y and G. These open circuits deenergize contactor coil C. The condenser and compressor motors stop. After a 30-sec. delay, the blower motor stops. The unit is in a “standby” condition, waiting for the next “call for cooling” from the room thermostat.

MAINTENANCE

To ensure continuing high performance and to minimize the possibility of premature equipment failure, periodic maintenance must be performed on this equipment. This combination heating/cooling unit should be inspected at least once each year by a qualified service person. To troubleshoot cooling or heating of units, refer to Tables 16–18.

NOTE: Consult your local dealer about the availability of a maintenance contract.

Table 14—PY1P Wet Coil Pressure Drop

UNIT SIZE PY1P	AIRFLOW (CFM)	PRESSURE DROP (IN. WG)
018	500	0.049
	600	0.070
	700	0.095
024	700	0.077
	800	0.100
	900	0.127
030	900	0.065
	1000	0.080
	1100	0.097
036	1100	0.084
	1200	0.100
	1300	0.177
042	1300	0.103
	1400	0.120
	1500	0.138
048	1500	0.088
	1600	0.100
	1700	0.113
060	1900	0.108
	2000	0.120
	2100	0.132

⚠ WARNING: The ability to properly perform maintenance on this equipment requires certain expertise, mechanical skills, tools, and equipment. If you do not possess these, do not attempt to perform any maintenance on this equipment other than those procedures recommended in the User’s Manual. FAILURE TO HEED THIS WARNING COULD RESULT IN SERIOUS INJURY AND POSSIBLE DAMAGE TO THIS EQUIPMENT.

- ⚠ WARNING:** Failure to follow these warnings could result in serious injury:
1. First, turn off gas supply to the unit. Then turn off electrical power to the unit and install lockout tag before performing any maintenance or service on the unit.
 2. Use extreme caution when removing panels and parts. As with any mechanical equipment, personal injury can result from sharp edges, etc.
 3. Never place anything combustible either on, or in contact with, the unit.
 4. Should overheating occur or the gas supply fail to shut off, turn off external main manual gas valve to the unit. Then shut off electrical supply and install lockout tag.
-

⚠ CAUTION: Errors made when reconnecting wires may cause improper and dangerous operation. Label all wires prior to disconnection when servicing.

The minimum maintenance requirements for this equipment are as follows:

**Table 11—Dry Coil Air Delivery* – Horizontal Downflow Discharge –
Unit PY1P018-060 (Deduct 10 percent for 208 Volts)**

230 AND 460 VOLT														
Unit	Motor Speed		External Static Pressure (in. wg)											
			0.0	0.1	0.2	0.3	0.4	0.5	0.6	0.7	0.8	0.9	1.0	
018	Low	Watts	227	212	196	177	165	153	—	—	—	—	—	—
		Cfm	1082	1016	929	796	668	428	—	—	—	—	—	—
	Med	Watts	—	—	—	—	—	—	—	—	—	—	—	—
		Cfm	—	—	—	—	—	—	—	—	—	—	—	—
	High	Watts	287	275	266	253	242	234	226	—	—	—	—	—
		Cfm	1270	1179	1054	932	780	633	372	—	—	—	—	—
024	Low	Watts	280	275	270	267	264	262	260	—	—	—	—	—
		Cfm	950	880	825	750	670	580	400	—	—	—	—	—
	Med	Watts	380	375	365	360	355	350	344	335	312	—	—	—
		Cfm	1220	1150	1090	1025	970	860	760	620	450	—	—	—
	High	Watts	485	475	470	460	455	445	437	430	415	385	—	—
		Cfm	1475	1440	1350	1275	1200	1125	1025	925	750	400	—	—
030	Low	Watts	280	275	270	267	264	262	260	—	—	—	—	—
		Cfm	950	880	825	750	670	580	400	—	—	—	—	—
	Med	Watts	380	375	365	360	355	350	344	335	312	—	—	—
		Cfm	1220	1150	1090	1025	970	860	760	620	450	—	—	—
	High	Watts	485	475	470	460	455	445	437	430	415	385	—	—
		Cfm	1475	1440	1350	1275	1200	1125	1025	925	750	400	—	—
036	Low	Watts	576	566	556	538	512	497	481	466	450	435	—	—
		Cfm	1430	1403	1365	1263	1157	1068	973	900	827	704	—	—
	Med	Watts	680	671	660	624	604	620	602	558	534	512	496	—
		Cfm	1720	1630	1538	1439	1346	1267	1167	1126	1018	858	781	—
	High	Watts	810	800	790	782	766	742	723	709	688	661	627	—
		Cfm	1800	1745	1660	1600	1547	1465	1360	1270	1163	967	876	—
042	Low	Watts	—	675	660	650	640	630	620	610	595	580	—	—
		Cfm	—	1454	1387	1326	1275	1204	1142	1081	995	918	—	—
	Med	Watts	—	886	855	825	795	778	765	750	735	718	700	—
		Cfm	—	1515	1458	1406	1350	1285	1224	1163	1091	1013	932	—
	High	Watts	—	—	—	1000	950	925	910	890	875	855	833	—
		Cfm	—	—	—	1551	1488	1424	1360	1296	1233	1148	1071	—
048	Low	Watts	—	727	712	700	688	666	644	622	595	569	—	—
		Cfm	—	1678	1639	1600	1561	1500	1440	1379	1289	1198	—	—
	Med	Watts	—	853	836	821	807	782	756	730	699	667	640	—
		Cfm	—	1914	1870	1825	1780	1711	1642	1573	1470	1367	1270	—
	High	Watts	—	979	959	943	927	897	868	838	802	766	730	—
		Cfm	—	2150	2100	2050	2000	1922	1845	1767	1600	1535	1419	—
060	Low	Watts	1033	949	864	836	822	808	772	737	705	674	642	—
		Cfm	2105	2057	2009	1943	1909	1876	1823	1770	1698	1627	1531	—
	Med	Watts	1084	1054	1024	994	971	955	928	897	867	835	803	—
		Cfm	2318	2248	2179	2110	2058	2000	1932	1885	1829	1740	1638	—
	High	Watts	—	—	1184	1152	1120	1102	1084	1056	1029	997	965	—
		Cfm	—	—	2349	2278	2207	2124	2041	2000	1960	1853	1745	—

* Air delivery values are without air filter and are for dry coil (See Table 14—PY1P Wet Coil Pressure Drop).

NOTE: Deduct field-supplied air filter pressure drop and wet coil pressure drop to obtain external static pressure available for ducting.

Table 12—Filter Pressure Drop (In. wg)

UNIT SIZE	FILTER SIZE	CFM																			
		500	600	700	800	900	1000	1100	1200	1300	1400	1500	1600	1700	1800	1900	2000	2100	2200	2300	
018, 024, 030	20 X 20 X 1	0.05	0.07	0.08	0.10	0.12	0.13	0.14	0.15	—	—	—	—	—	—	—	—	—	—	—	—
036	20 X 24 X 1	—	—	—	—	0.09	0.10	0.11	0.13	0.14	0.15	0.16	—	—	—	—	—	—	—	—	—
042, 048, 060	24 X 30 X 1	—	—	—	—	—	—	—	0.07	0.08	0.09	0.10	0.11	0.12	0.13	0.14	0.15	0.16	0.17	0.18	—

1. Inspect air filter(s) each month. Clean or replace when necessary. Certain geographical locations may require more frequent inspections.
2. Inspect indoor coil, outdoor coil, drain pan, and condensate drain each cooling season for cleanliness. Clean at least once per heating / cooling season or more often if needed.
3. Inspect blower motor and wheel for cleanliness at the beginning of each heating and cooling season. Clean when necessary. For *first* heating and cooling season, inspect blower wheel bi-monthly to determine proper cleaning frequency.
4. Check electrical connections for tightness and controls for proper operation each heating and cooling season. Service when necessary.
5. Ensure wires are not contacting refrigerant tubes or sharp sheet metal edges.

**Table 13—Dry Coil Air Delivery* – Horizontal and Downflow Discharge –
Unit PY2P024-060 (Deduct 10 percent for 208 Volts)**

230 AND 460 VOLT														
Unit	Motor Speed		External Static Pressure (In. wg)											
			0.0	0.1	0.2	0.3	0.4	0.5	0.6	0.7	0.8	0.9	1.0	
024	Low	Watts	281	282	281	278	276	—	—	—	—	—	—	—
		Cfm	899	828	757	691	619	—	—	—	—	—	—	—
	Med	Watts	—	—	—	375	370	363	357	352	—	—	—	—
		Cfm	—	—	—	969	897	824	744	649	—	—	—	—
	High	Watts	—	—	—	—	—	468	457	444	431	423	—	—
		Cfm	—	—	—	—	—	994	913	826	730	620	—	—
030	Low	Watts	246	244	243	241	—	—	—	—	—	—	—	—
		Cfm	982	860	808	736	—	—	—	—	—	—	—	—
	Med	Watts	343	339	336	332	328	322	317	—	—	—	—	—
		Cfm	1233	1170	1109	1038	953	855	754	—	—	—	—	—
	High	Watts	—	—	—	—	441	432	421	410	400	—	—	—
		Cfm	—	—	—	—	1202	1111	1021	929	826	—	—	—
036	Low	Watts	—	470	458	445	430	415	399	384	—	—	—	—
		Cfm	—	1463	1406	1344	1273	1188	1091	983	—	—	—	—
	Med	Watts	—	—	514	501	487	471	455	438	422	—	—	—
		Cfm	—	—	1497	1428	1348	1255	1152	1042	929	—	—	—
	High	Watts	—	—	—	646	636	626	614	602	589	—	—	—
		Cfm	—	—	—	1491	1412	1325	1228	1120	1003	—	—	—
042	Low	Watts	643	625	614	605	593	574	549	518	485	454	—	—
		Cfm	1626	1614	1579	1532	1478	1421	1361	1295	1218	1120	—	—
	Med	Watts	—	—	—	—	726	695	661	625	591	561	540	—
		Cfm	—	—	—	—	1731	1672	1610	1541	1456	1345	1193	—
	High	Watts	—	—	—	—	—	—	—	790	766	742	713	—
		Cfm	—	—	—	—	—	—	—	1699	1602	1494	1367	—
048	Low	Watts	614	588	577	572	566	556	539	517	491	—	—	—
		Cfm	1591	1549	1518	1490	1460	1421	1372	1312	1242	—	—	—
	Med	Watts	778	756	738	719	699	676	650	623	596	572	555	—
		Cfm	1854	1837	1804	1759	1705	1643	1577	1508	1440	1375	1315	—
	High	Watts	—	—	—	—	896	862	829	800	775	752	728	—
		Cfm	—	—	—	—	1956	1879	1797	1709	1615	1514	1406	—
060	Low	Watts	834	813	782	746	712	680	652	626	—	—	—	—
		Cfm	2016	1955	1898	1840	1781	1717	1646	1566	—	—	—	—
	Med	Watts	941	889	851	822	797	772	745	714	679	639	—	—
		Cfm	2379	2233	2124	2038	1964	1892	1814	1727	1626	1511	—	—
	High	Watts	—	—	960	949	920	883	845	812	783	753	—	—
		Cfm	—	—	2497	2224	2075	1986	1915	1831	1721	1588	—	—

* Air delivery values are without air filter and are for dry coil (See Table 15-PY2P Wet Coil Pressure Drop table).

NOTE: Deduct field-supplied air filter pressure drop and wet coil pressure drop to obtain external static pressure available for ducting.

6. Check and inspect heating section before each heating season. Clean and adjust when necessary.

7. Check flue hood and remove any obstructions, if necessary.

E. AIR FILTER

⚠ CAUTION: Never operate the unit without a suitable air filter in the return-air duct system. Always replace the filter with the same dimensional size and type as originally installed (See Tables 1 and 2 for recommended filter sizes).

Inspect air filter(s) at least once each month and replace (throwaway-type) or clean (cleanable-type) at least twice during each heating and cooling season or whenever the filter(s) becomes clogged with dust and/or lint.

F. EVAPORATOR BLOWER AND MOTOR

NOTE: All motors are permanently lubricated. Do not attempt to lubricate these motors.

For longer life, operating economy, and continuing efficiency, clean accumulated dirt and grease from the blower wheel and motor annually.

⚠ WARNING: Before cleaning the blower motor and wheel, disconnect gas supply. Then turn off and tag electrical power to the unit. Failure to adhere to this warning could cause serious injury or death.

CLEANING THE BLOWER MOTOR AND WHEEL

1. Remove and disassemble blower assembly as follows:
 - a. Remove unit access panel.
 - b. Disconnect motor lead from blower relay (BM). Disconnect yellow lead from terminal L2 of the contactor.

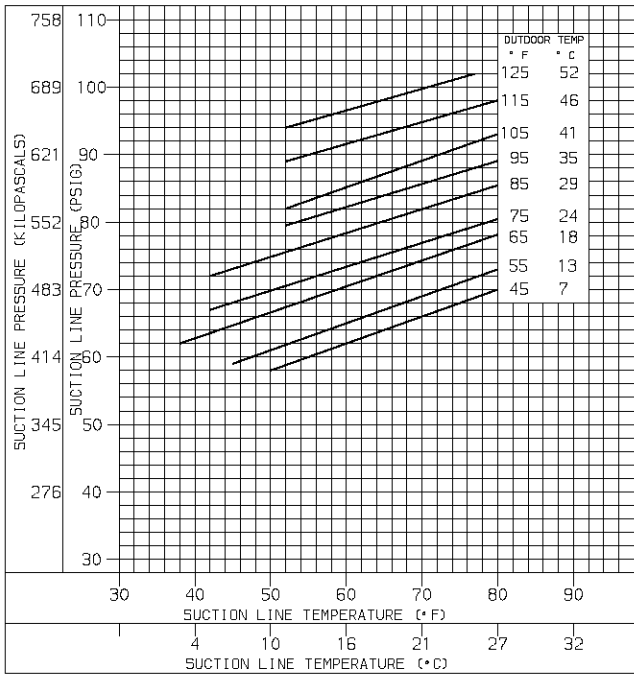

Fig. 18—Cooling Charging Chart, PY1P018 Units

C00046

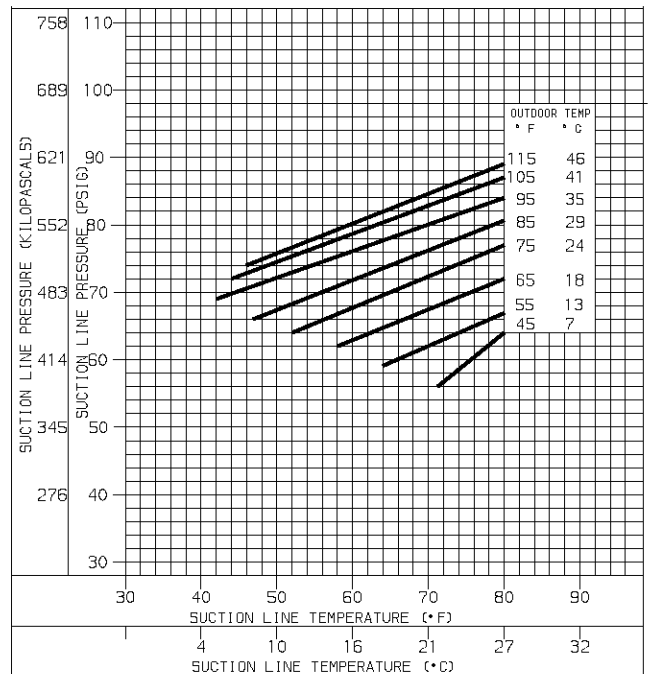

Fig. 19—Cooling Charging Chart, PY1P024 Units

C00042

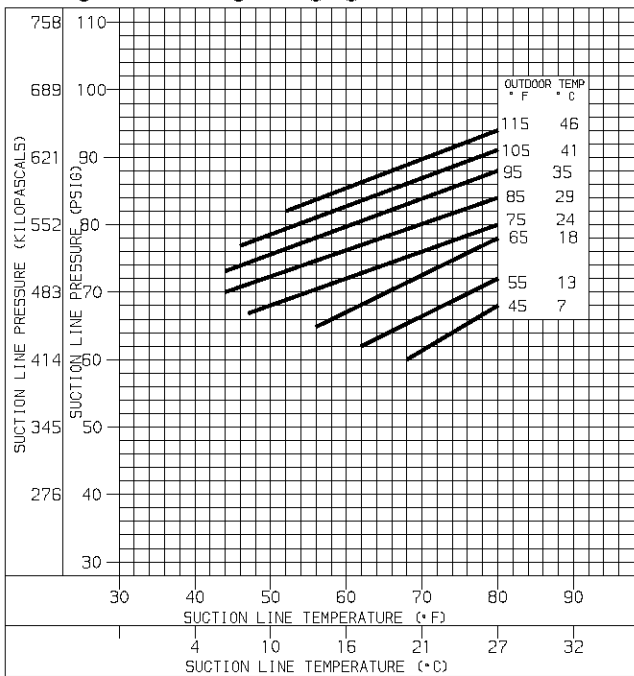

Fig. 20—Cooling Charging Chart, PY1P030 Units

C00043

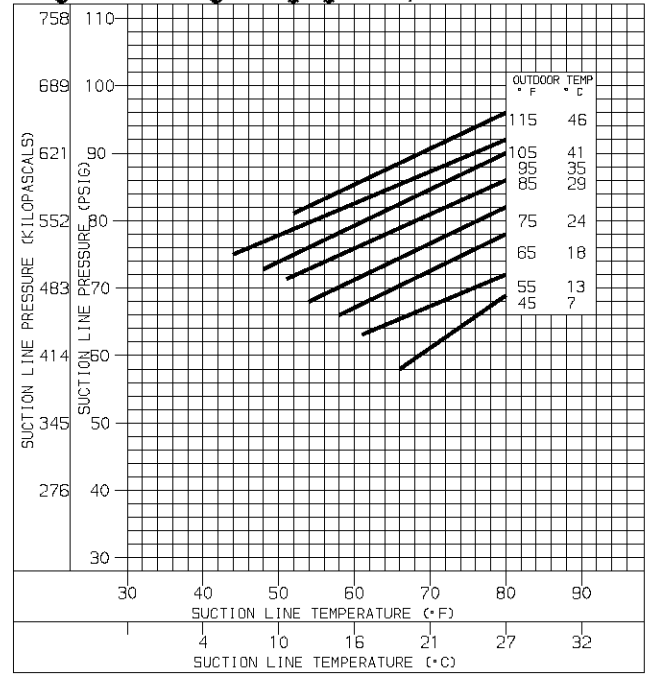

Fig. 21—Cooling Charging Chart, PY1P036 Units

C00044

- c. On *all* units, remove blower assembly from unit. Remove screws securing blower to blower partition and slide assembly out. Be careful not to tear insulation in blower compartment.
 - d. Ensure proper reassembly by marking blower wheel and motor in relation to blower housing before disassembly.
 - c. Loosen setscrew(s) that secures wheel to motor shaft. Remove screws that secure motor mount brackets to housing, and slide motor and motor mount out of housing.
2. Remove and clean blower wheel as follows:
 - a. Ensure proper reassembly by marking wheel orientation.
 - b. Lift wheel from housing. When handling and/or cleaning blower wheel, be sure not to disturb balance weights (clips) on blower wheel vanes.
 - c. Remove caked-on dirt from wheel and housing with a brush. Remove lint and/or dirt accumulations from wheel and housing with vacuum cleaner, using soft brush attachment. Remove grease and oil with mild solvent.
 - d. Reassemble wheel into housing.
 - e. Reassemble motor into housing. Be sure setscrews are tightened on motor shaft flats and not on round part of shaft.
 - f. Reinstall unit access panel.

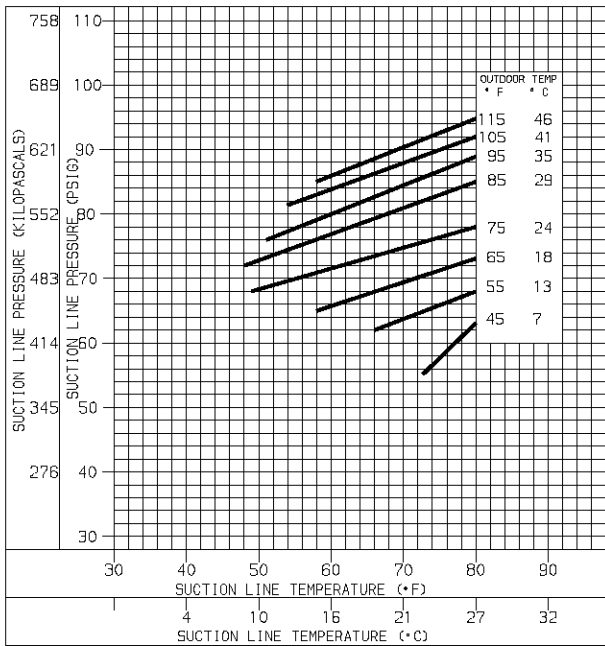

Fig. 22—Cooling Charging Chart, PY1P042 Units C00045

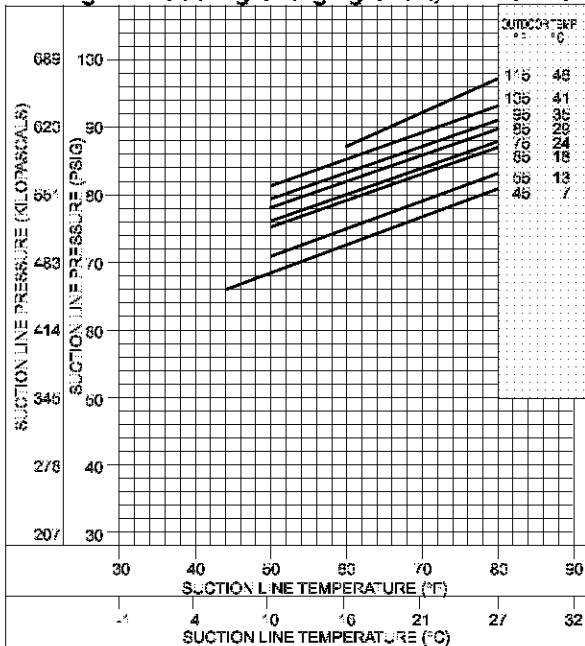

Fig. 24—Cooling Charging Chart, PY1P060 Units C00048

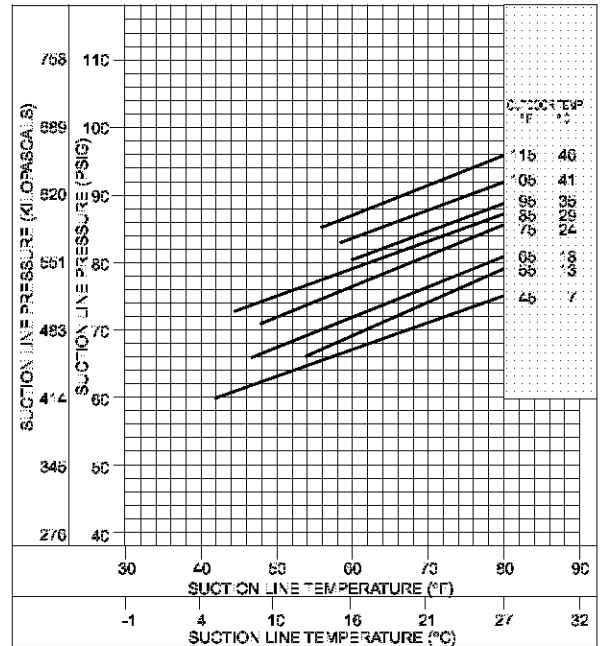

Fig. 23—Cooling Charging Chart, PY1P048 Units C00047

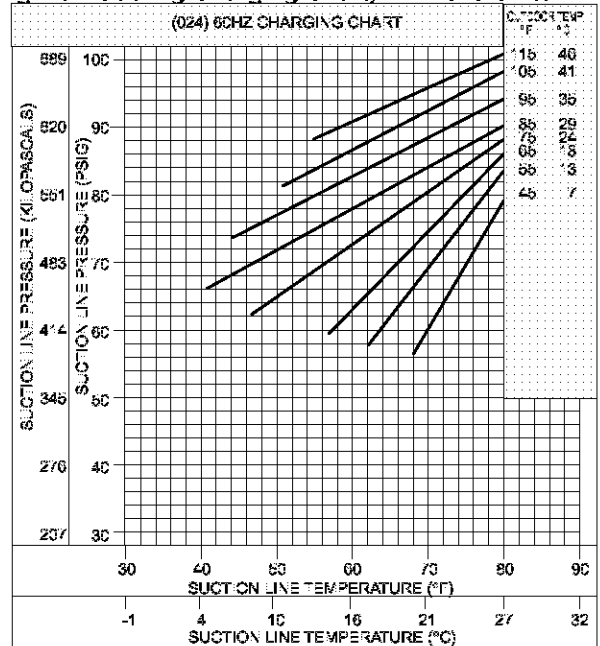

Fig. 25—Cooling Charging Chart, PY2P024 Units C00049

3. Restore electrical power to unit. Start unit and check for proper blower rotation and motor speeds during heating and cooling cycles.

G. FLUE GAS PASSAGEWAYS

To inspect the flue collector box and upper areas of the heat exchanger:

1. Remove the combustion blower wheel and motor assembly according to directions in the *Combustion-Air Blower* section.
2. Remove the 3 screws holding the blower housing to the flue collector box cover (See Fig. 31–34).
3. Remove the 12 screws holding the flue collector box cover (See Fig. 33–34) to the heat exchanger assembly. Inspect the heat exchangers.
4. Clean all surfaces, as required, using a wire brush.

H. COMBUSTION-AIR BLOWER

Clean periodically to assure proper airflow and heating efficiency. Inspect blower wheel every fall and periodically during the heating season. For the first heating season, inspect blower wheel bi-monthly to determine proper cleaning frequency.

To inspect blower wheel, remove draft hood assembly. Shine a flashlight into opening to inspect wheel. If cleaning is required, remove motor and wheel as follows:

1. Remove unit access panel (See Fig. 32).
2. Remove the 7 screws that attach induced-draft motor mounting plate to blower housing (See Fig. 33).

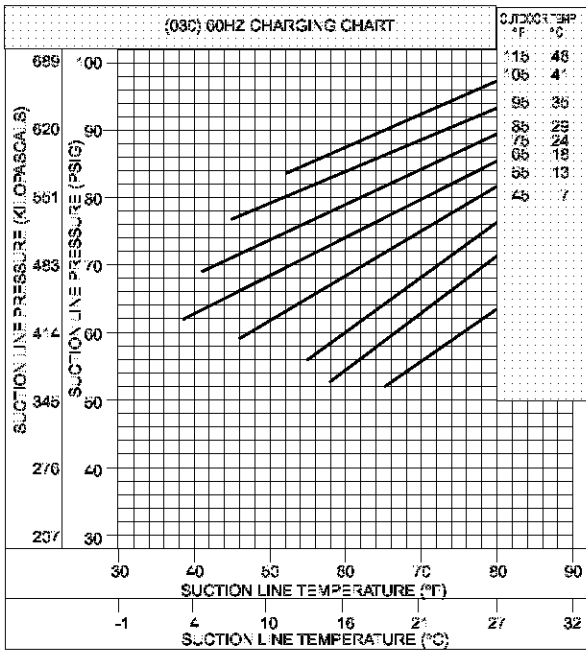

Fig. 26—Cooling Charging Chart, PY2P030 Units C99046

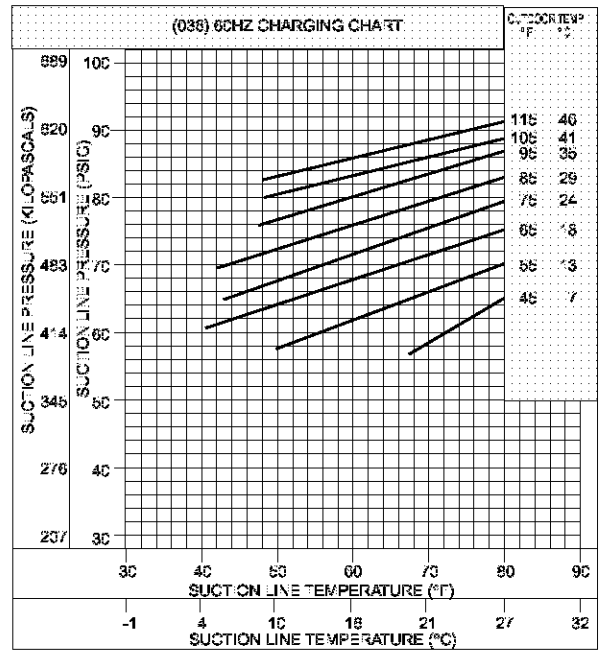

Fig. 27—Cooling Charging Chart, PY2P036 Units C00051

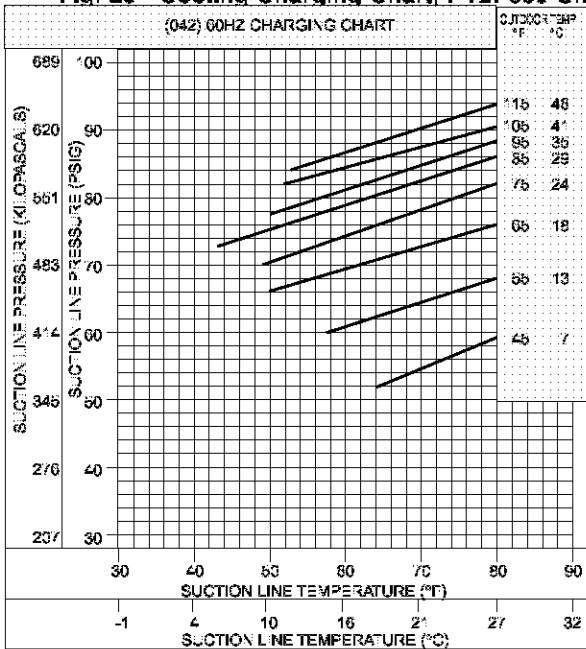

Fig. 28—Cooling Charging Chart, PY2P042 Units C00052

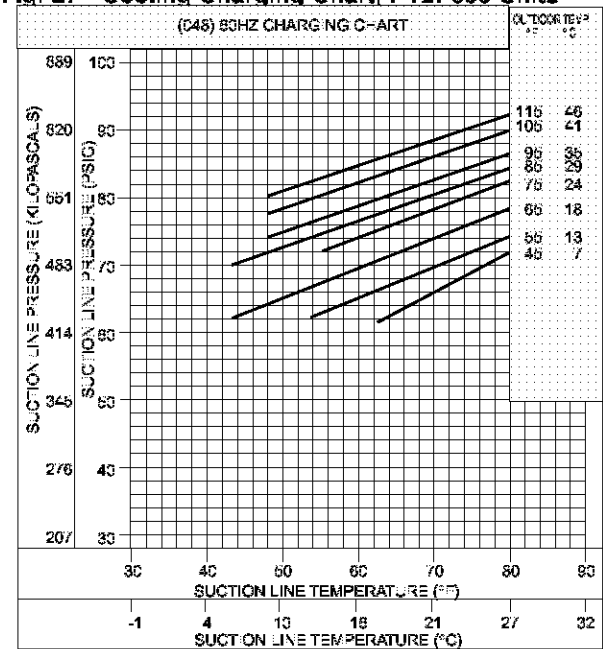

Fig. 29—Cooling Charging Chart, PY2P048 Units C00053

3. Slide the motor and blower wheel assembly out of the blower housing (See Fig. 33). Clean the blower wheel. If additional cleaning is required, continue with Steps 4 and 5.
4. To remove blower, remove 2 setscrews.
5. To remove motor and cooling fan assembly, remove 4 screws that hold blower housing to mounting plate.
6. To reinstall, reverse the procedure outlined above.

I. LIMIT SWITCH

Remove unit access panel. Limit switch is located on the blower partition.

J. BURNER IGNITION

Unit is equipped with a direct spark ignition 100 percent lockout system. Ignition module is located in the control box. Module contains a self-diagnostic LED. During servicing, refer to label diagram for LED interpretation.

If lockout occurs, unit may be reset by either momentarily interrupting power supply to unit or by turning selector switch to OFF position at the thermostat.

K. MAIN BURNERS

At the beginning of each heating season, inspect for deterioration or blockage due to corrosion or other causes. Observe the main burner flames and adjust, if necessary.

Table 15—PY2P Wet Coil Pressure Drop

UNIT SIZE PY2P	AIRFLOW (CFM)	PRESSURE DROP (IN. WG)
024	700	0.0535
	800	0.067
	900	0.123
030	900	0.0687
	1000	0.083
	1100	0.150
036	1100	0.084
	1200	0.100
	1300	0.177
042	1300	0.099
	1400	0.177
	1500	0.204
048	1500	0.199
	1600	0.137
	1700	0.156
060	1900	0.108
	2000	0.120
	2100	0.132

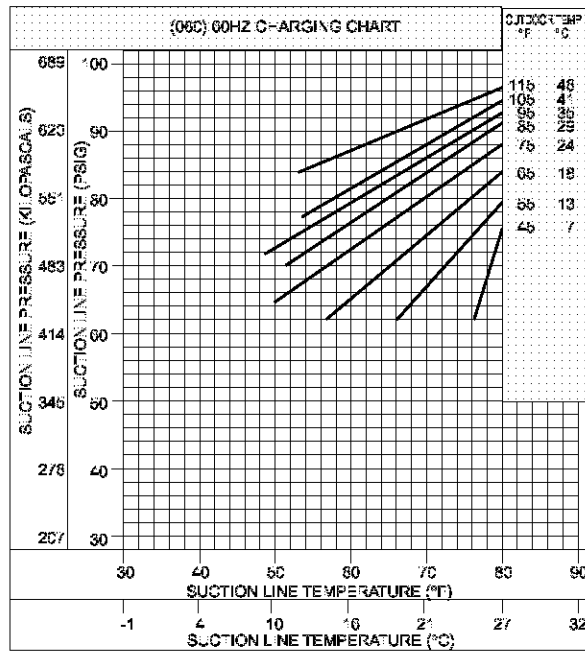

C00054

Fig. 30—Cooling Charging Chart, PY2P060 Units

⚠ CAUTION: When servicing gas train, do not hit or plug orifice spuds.

REMOVAL OF GAS TRAIN

To remove the gas train for servicing:

1. Shut off main gas valve.
2. Shut off power to unit and install lockout tag.
3. Remove unit access panel (See Fig. 32).
4. Disconnect gas piping at unit gas valve.
5. Remove wires connected to gas valve. Mark each wire.
6. Remove ignitor and sensor wires at the ignitor module.
7. Remove the mounting screw that attaches the burner rack to the unit base (See Fig. 31).
8. Slide the burner rack out of the unit (See Fig. 31 and 34).
9. To reinstall, reverse the procedure outlined above.

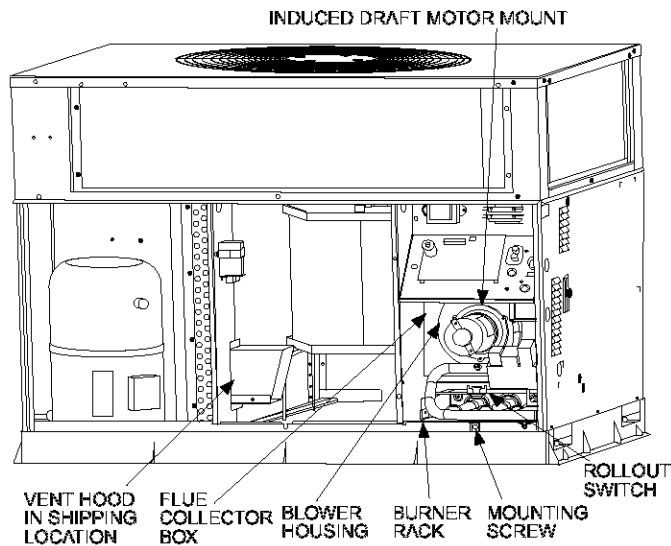

C99022

Fig. 31—Blower Housing and Flue Collector Box

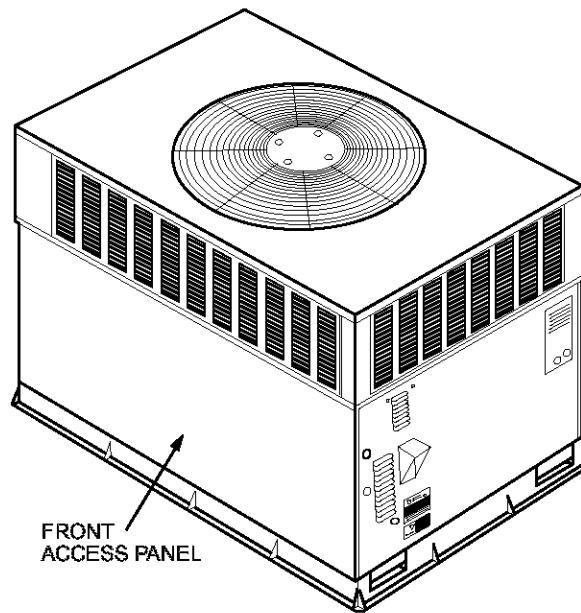

C99091

Fig. 32—Unit Access Panel

L. CONDENSER COIL, EVAPORATOR COIL, AND CONDENSATE DRAIN PAN

Inspect the condenser coil, evaporator coil, and condensate drain pan at least once each year or more often if necessary.

The coils are easily cleaned when dry; therefore, inspect and clean the coils either before or after each cooling season. Remove all obstructions, including weeds and shrubs, that interfere with the airflow through the condenser coil.

Straighten bent fins with a fin comb. If coated with dirt or lint, clean the coils with a vacuum cleaner, using the soft brush attachment. Be careful not to bend the fins. If coated with oil or grease, clean the coils with a mild detergent-and-water solution. Rinse coils with clear water, using a garden hose. Be careful not to splash water on motors, insulation, wiring, or air filter(s). For best results, spray condenser coil fins from inside to outside the unit. On units with an outer and inner condenser coil, be sure to clean between the coils. Be sure to flush all dirt and debris from the unit base.

Inspect the drain pan and condensate drain line when inspecting the coils. Clean the drain pan and condensate drain by removing all foreign matter from the pan. Flush the pan and drain tube with clear water. Do not splash water on the insulation, motor, wiring, or air filter(s). If the drain tube is restricted, clear it with a “plumbers snake” or similar probe device. Ensure that the auxiliary drain port above the drain tube is also clear

M. CONDENSER FAN

⚠ CAUTION: Keep the condenser fan free from all obstructions to ensure proper cooling operation. Never place articles on top of the unit. Damage to unit may result.

1. Remove 6 screws holding condenser grille and motor to top cover.
2. Turn motor/grille assembly upside down on top cover to expose the fan blade.

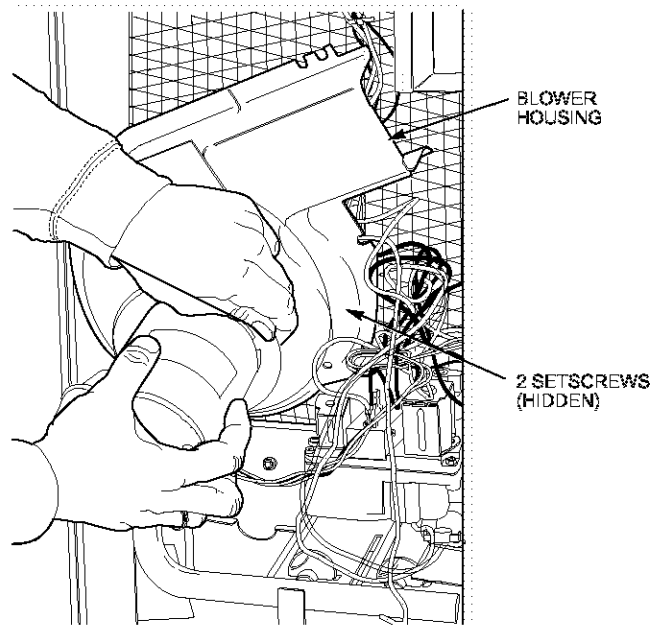

C99085

Fig. 33—Removal of Motor and Blower Wheel

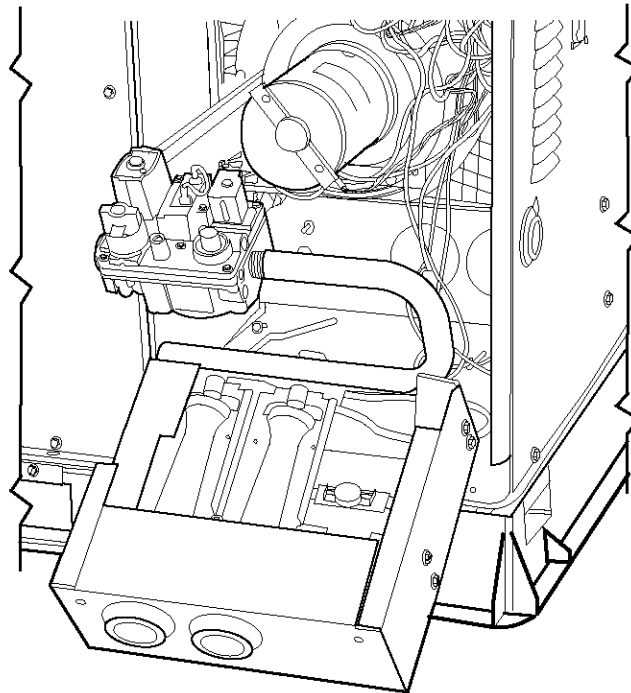

C99086

Fig. 34—Burner Rack Removed

3. Inspect the fan blades for cracks or bends.
4. If fan needs to be removed, loosen the setscrew and slide the fan off the motor shaft.
5. When replacing fan blade, position blade so the hub is 1/8 in. away from the motor end (1/8 in. of motor shaft will be visible. See Fig. 12).
6. Ensure that setscrew engages the flat area on the motor shaft when tightening.
7. Replace grille.

N. ELECTRICAL CONTROLS AND WIRING

Inspect and check the electrical controls and wiring annually. *Be sure to turn off the gas supply, and then the electrical power to the unit.*

Remove access panel to locate all the electrical controls and wiring. Check all electrical connections for tightness. Tighten all screw connections. If any smoky or burned connections are noticed, disassemble the connection, clean all the parts, restrip the wire end and reassemble the connection properly and securely.

After inspecting the electrical controls and wiring, replace the access panel. Start the unit, and observe at least one complete heating cycle and one complete cooling cycle to ensure proper operation. If discrepancies are observed in either or both operating cycles, or if a suspected malfunction has occurred, check each electrical component with the proper electrical instrumentation. Refer to the unit wiring label when making these checkouts.

NOTE: Refer to the heating and/or cooling sequence of operation in this publication as an aid in determining proper control operation

O. REFRIGERANT CIRCUIT

Annually inspect all refrigerant tubing connections and the unit base for oil accumulations. Detecting oil generally indicates a refrigerant leak.

⚠ WARNING: System under pressure. Relieve pressure and recover all refrigerant before system repair or final unit disposal to avoid serious injury or death. Use all service ports and open all flow-control devices, including solenoid valves.

If oil is detected or if low cooling performance is suspected, leak-test all refrigerant tubing using an electronic leak-detector, halide torch, or liquid-soap solution. If a refrigerant leak is detected, refer to the *Check for Refrigerant Leaks* section.

If no refrigerant leaks are found and low cooling performance is suspected, refer to the *Checking and Adjusting Refrigerant Charge* section.

P. GAS INPUT

The gas input does not require checking unless improper heating performance is suspected. If a problem exists, refer to the *Start-Up* section.

Q. EVAPORATOR AIRFLOW

The heating and/or cooling airflow does not require checking unless improper performance is suspected. *If a problem exists, be sure that all supply- and return-air grilles are open and free from obstructions, and that the air filter is clean.* When necessary, refer to the *Indoor Airflow and Airflow Adjustments* section to check the system airflow.

R. METERING DEVICE — ACUTROL DEVICE

This metering device is a fixed orifice and is located in the header to the evaporator coil.

S. LIQUID LINE STRAINER

The liquid line strainer (to protect metering device) is made of wire mesh and located in the liquid line on the inlet side of the metering device.

TROUBLESHOOTING

Use the *Troubleshooting Guides* (See Tables 16–18) if problems occur with these units.

START-UP CHECKLIST

Use the *Start-Up Checklist* to ensure proper start-up procedures are followed.

Table 16—Troubleshooting Guide—Cooling

SYMPTOM	CAUSE	REMEDY
Compressor and condenser fan will not start.	Power Failure	Call power company.
	Fuse blown or circuit breaker tripped	Replace fuse or reset circuit breaker.
	Defective thermostat, contactor, transformer, or control relay	Replace component.
	Insufficient line voltage	Determine cause and correct.
	Incorrect or faulty wiring	Check wiring diagram and rewire correctly.
	Thermostat setting too high	Lower thermostat setting below room temperature.
Compressor will not start but condenser fan runs.	Faulty wiring or loose connections in compressor circuit	Check wiring and repair or replace.
	Compressor motor burned out, seized, or internal overload open	Determine cause Replace compressor.
	Defective run/start capacitor, overload, start relay	Determine cause and replace.
	One leg of 3-phase power dead	Replace fuse or reset circuit breaker. Determine cause.
Three-phase scroll compressor (PY1P048 and PY2P030-060 only) makes excessive noise, and there may be a low pressure differential.	Scroll compressor is rotating in the wrong direction	Correct the direction of rotation by reversing the 3-phase power leads to the unit. Shut down unit to allow pressures to equalize.
Compressor cycles (other than normally satisfying thermostat).	Refrigerant overcharge or undercharge	Recover refrigerant, evacuate system, and recharge to capacities shown on nameplates.
	Defective compressor	Replace and determine cause.
	Insufficient line voltage	Determine cause and correct.
	Blocked condenser	Determine cause and correct.
	Defective run/start capacitor, overload or start relay	Determine cause and replace.
	Defective thermostat	Replace thermostat.
	Faulty condenser-fan motor or capacitor	Replace.
	Restriction in refrigerant system	Locate restriction and remove.
Compressor operates continuously.	Dirty air filter	Replace filter.
	Unit undersized for load	Decrease load or increase unit size.
	Thermostat set too low	Reset thermostat.
	Low refrigerant charge	Locate leak, repair, and recharge.
	Leaking valves in compressor	Replace compressor.
	Air in system	Recover refrigerant, evacuate system, and recharge.
	Condenser coil dirty or restricted	Clean coil or remove restriction.
	Dirty air filter	Replace filter.
Excessive head pressure.	Dirty condenser coil	Clean coil.
	Refrigerant overcharged	Recover excess refrigerant.
	Air in system	Recover refrigerant, evacuate system, and recharge.
	Condenser air restricted or air short-cycling	Determine cause and correct.
Head pressure too low.	Low refrigerant charge	Check for leaks, repair, and recharge.
	Compressor valves leaking	Replace compressor.
	Restriction in liquid tube	Remove restriction.
Excessive suction pressure.	High heat load	Check for source and eliminate.
	Compressor valves leaking	Replace compressor.
	Refrigerant overcharged	Recover excess refrigerant.
Suction pressure too low.	Dirty air filter	Replace Filter.
	Low refrigerant charge	Check for leaks, repair, and recharge.
	Metering device or low side restricted	Remove source of restriction.
	Insufficient evaporator airflow	Increase air quantity. Check filter — replace if necessary.
	Temperature too low in conditioned area	Reset thermostat.
	Outdoor ambient below 40°F	Install low-ambient kit.
	Field-installed filter-drier restricted	Replace.

Table 17—Troubleshooting Guide—Heating

SYMPTOM	CAUSE	REMEDY
Burners will not ignite.	Water in gas line	Drain. Install drip leg.
	No power to furnace	Check power supply fuses, wiring, or circuit breaker.
	No 24-v power supply to control circuit	Check transformer.
		NOTE: Some transformers have internal overcurrent protection that requires a cool-down period to reset.
		Check all wiring and wirenut connections
	Miswired or loose connections	Replace thermostat.
	Burned-out heat anticipator in thermostat	Run continuity check. Replace wire if necessary.
	Broken thermostat wire	Check flame ignition and sense electrode positioning. Adjust as necessary.
Misaligned spark electrodes	1. Check gas line for air. Purge as necessary. NOTE: After purging gas line of air, wait at least 5 minutes for any gas to dissipate before attempting to light unit. 2. Check gas valve.	
Inadequate heating.	Dirty air filter	Clean or replace filter as necessary.
	Gas input to furnace too low	Check gas pressure at manifold match with that on unit nameplate.
	Unit undersized for application	Replace with proper unit or add additional unit.
	Restricted airflow	Clean or replace filter. Remove any restriction.
	Blower speed too low	Use faster speed tap if available, or install alternate motor.
Poor flame characteristics.	Limit switch cycles main burners	Check rotation of blower, thermostat heat anticipator settings, temperature rise of unit. Adjust as necessary.
	Incomplete combustion results in: Aldehyde odors, carbon monoxide, sooting flame, floating flame	1. Tighten all screws around burner compartment.
		2. Cracked heat exchanger. Replace.
		3. Unit overfired. Reduce input (change orifices or adjust gas line or manifold pressure).
		4. Check burner alignment.

Table 18—Troubleshooting Guide—LED Error Codes

SYMPTOM	CAUSE	REMEDY
Hardware failure. (LED OFF)	Loss of power to control module (IGC)*.	Check 5-amp fuse on IGC*, power to unit, 24-v circuit breaker, and transformer. Units without a 24-v circuit breaker have an internal overload in the 24-v transformer. If the overload trips, allow 10 minutes for automatic reset.
Fan ON/OFF delay modified (LED/FLASH)	High limit switch opens during heat exchanger warm-up period before fan-on delay expires. Limit switch opens within three minutes after blower-off delay timing in Heating mode.	Ensure unit is fired on rate; ensure temperature rise is correct. Ensure unit's external static pressure is within application guidelines.
Limit switch faults. (LED 2 flashes)	High temperature limit switch is open.	Check the operation of the indoor (evaporator) fan motor. Ensure that the supply-air temperature rise is in accordance with the range on the unit nameplate.
Flame sense fault. (LED 3 flashes)	The IGC* sensed flame that should not be present.	Reset unit. If problem persists, replace control board.
4 consecutive limit switch faults. (LED 4 flashes)	Inadequate airflow to unit	Check operation of indoor (evaporator) fan motor and that supply-air temperature rise agrees with range on unit nameplate information.
Ignition lockout. (LED 5 flashes)	Unit unsuccessfully attempted ignition for 15 minutes.	Check ignitor and flame sensor electrode spacing, gaps, etc. Ensure that flame sense and ignition wires are properly terminated. Verify that unit is obtaining proper amount of gas.
Induced-draft motor fault. (LED 6 flashes)	IGC does not sense that induced-draft motor is operating.*	Check for proper voltage. If motor is operating, check the speed sensor plug/IGC Terminal J2 connection. Proper connection: PIN 1..... White PIN 2..... Red PIN 3..... Black.
Rollout switch fault. (LED 7 flashes)	Rollout switch has opened.	Rollout switch will automatically reset, but IGC* will continue to lock-out unit. Check gas valve operation. Ensure that induced-draft blower wheel is properly secured to motor shaft. Reset unit at unit disconnect.
Rollout control fault. (LED 8 flashes)	Microprocessor has sensed an error in the software or hardware.	If error code is not cleared by resetting unit power, replace the IGC*.
Temporary software lock out. (LED 9 flashes)	Electrical interference impeding IGC software	Reset 24-v. to control board or turn thermostat off, then on again. Fault will automatically reset itself in one (1) hour.

* **WARNING** ⚠ : If the IGC must be replaced, be sure to ground yourself to dissipate any electrical charge that may be present before handling new control board. The IGC is sensitive to static electricity and may be damaged if the necessary precautions are not taken.

IMPORTANT: Refer to Table 17—Troubleshooting Guide—Heating for additional troubleshooting analysis.

LEGEND

IGC — Integrated Gas Unit Controller

LED — Light-Emitting Diode

START-UP CHECKLIST
(Remove and Store in Job File)

I. PRELIMINARY INFORMATION

MODEL NO:
SERIAL NO:
DATE:
TECHNICIAN:
JOB LOCATION:

II. PRE-START-UP (insert checkmark in box as each item is completed)

- VERIFY THAT ALL PACKING MATERIALS HAVE BEEN REMOVED FROM UNIT
- VERIFY THAT CONDENSATE CONNECTION IS INSTALLED PER INSTALLATION INSTRUCTIONS
- CHECK ALL ELECTRICAL CONNECTIONS AND TERMINALS FOR TIGHTNESS
- CHECK GAS PIPING FOR LEAKS
- CHECK THAT INDOOR (EVAPORATOR) AIR FILTER IS CLEAN AND IN PLACE
- VERIFY THAT UNIT INSTALLATION IS LEVEL
- CHECK FAN WHEEL PROPELLER FOR LOCATION IN HOUSING ORIFICE AND SETSCREW TIGHTNESS

III. START-UP

ELECTRICAL

SUPPLY VOLTAGE L1-L2 _____ L2-L3 _____ L3-L1 _____
COMPRESSOR AMPS L1 _____ L2 _____ L3 _____
COMPRESSOR AMPS L1 _____ L2 _____ L3 _____
INDOOR (EVAPORATOR) FAN AMPS _____

TEMPERATURES

OUTDOOR (CONDENSER) AIR TEMPERATURE: _____ DB
RETURN-AIR TEMPERATURE: _____ DB _____ WB
COOLING SUPPLY AIR: _____ DB _____ WB
GAS HEAT SUPPLY AIR: _____

PRESSURES

GAS INLET PRESSURE _____ IN. WG
GAS MANIFOLD PRESSURE _____ IN. WG
REFRIGERANT SUCTION _____ PSIG SUCTION LINE TEMP* _____
REFRIGERANT DISCHARGE _____ PSIG DISCHARGE LINE TEMP† _____

- VERIFY REFRIGERANT CHARGE USING CHARGING TABLES
- VERIFY THAT 3-PHASE SCROLL COMPRESSOR (PY1P048 and PY2P030-060) IS ROTATING IN CORRECT DIRECTION.

* Measured at suction inlet to compressor

† Measured at liquid line leaving condenser

