

OWNER'S MANUAL

Color Television

MS3252S

MS3652S

MAGNAVOX

Smart. Very smart.®



NEED HELP? CALL US!

MAGNAVOX REPRESENTATIVES ARE READY TO HELP YOU WITH ANY QUESTIONS ABOUT YOUR NEW PRODUCT. WE CAN GUIDE YOU THROUGH CONNECTIONS, FIRST-TIME SETUP, AND ANY OF THE FEATURES. WE WANT YOU TO START ENJOYING YOUR NEW PRODUCT RIGHT AWAY.

CALL US BEFORE YOU CONSIDER RETURNING THE PRODUCT.

1-800-705-2000

OR VISIT US ON THE WEB AT WWW.MAGNAVOX.COM

IMPORTANT!

RETURN YOUR WARRANTY REGISTRATION CARD WITHIN 10 DAYS.

SEE WHY INSIDE.

Return your Warranty Registration card today to ensure you receive all the benefits you're entitled to.

Once your MAGNAVOX purchase is registered, you're eligible to receive all the privileges of owning a MAGNAVOX product. So complete and return the Warranty Registration Card enclosed with your purchase at once. And take advantage of these important benefits.

Warranty Verification

Registering your product within 10 days confirms your right to maximum protection under the terms and conditions of your MAGNAVOX warranty.

Owner Confirmation

Your completed Warranty Registration Card serves as verification of ownership in the event of product theft or loss.

Model Registration

Returning your Warranty Registration Card right away guarantees you'll receive all the information and special offers which you qualify for as the owner of your model.

Congratulations on your purchase, and welcome to the "family!"



Dear MAGNAVOX product owner:

Thank you for your confidence in MAGNAVOX. You've selected one of the best-built, best-backed products available today. We'll do everything in our power to keep you happy with your purchase for many years to come.

As a member of the MAGNAVOX "family," you're entitled to protection by one of the most comprehensive warranties and outstanding service networks in the industry.

What's more, your purchase guarantees you'll receive all the information and special offers for which you qualify, plus easy access to accessories from our convenient home shopping network. Most importantly, you can count on our uncompromising commitment to your total satisfaction.

All of this is our way of saying welcome-and thanks for investing in a MAGNAVOX product.

P.S. Remember, to get the most from your MAGNAVOX product, you must return your Warranty Registration Card within 10 days. So please mail it to us right now!

Know these **safety** symbols

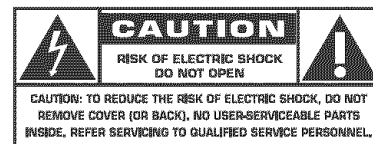

⚡ This "bolt of lightning" indicates uninsulated material within your unit may cause an electrical shock. For the safety of everyone in your household, please do not remove product covering.

⚠ The "exclamation point" calls attention to features for which you should read the enclosed literature closely to prevent operating and maintenance problems.

WARNING: TO PREVENT FIRE OR SHOCK HAZARD, DO NOT EXPOSE THIS EQUIPMENT TO RAIN OR MOISTURE.

CAUTION: To prevent electric shock, match wide blade of plug to wide slot, fully insert.

ATTENTION: Pour éviter les choc électriques, introduire la lame la plus large de la fiche dans la borne correspondante de la prise et pousser jusqu'au fond.

For Customer Use

Enter below the Serial No. which is located on the rear of the cabinet. Retain this information for future reference.

Model No. _____
Serial No. _____

Visit our World Wide Web Site at <http://www.magnavox.com>

IMPORTANT SAFETY INSTRUCTIONS

Read before operating equipment

1. Read these instructions.
2. Keep these instructions.
3. Heed all warnings.
4. Follow all instructions.
5. Do not use this apparatus near water.
6. Clean only with a dry cloth.
7. Do not block any of the ventilation openings. Install in accordance with the manufacturers instructions.
8. Do not install near any heat sources such as radiators, heat registers, stoves, or other apparatus (including amplifiers) that produce heat.
9. Do not defeat the safety purpose of the polarized or grounding-type plug. A polarized plug has two blades with one wider than the other. A grounding type plug has two blades and third grounding prong. The wide blade or third prong are provided for your safety. When the provided plug does not fit into your outlet, consult an electrician for replacement of the obsolete outlet.
10. Protect the power cord from being walked on or pinched particularly at plugs, convenience receptacles, and the point where they exit from the apparatus.
11. Only use attachments/accessories specified by the manufacturer.
12.  Use only with a cart, stand, tripod, bracket, or table specified by the manufacturer, or sold with the apparatus. When a cart is used, use caution when moving the cart/apparatus combination to avoid injury from tip-over.
13. Unplug this apparatus during lightning storms or when unused for long periods of time.
14. Refer all servicing to qualified service personnel. Servicing is required when the apparatus has been damaged in any way, such as power-supply cord or plug is damaged, liquid has been spilled or objects have fallen into apparatus, the apparatus has been exposed to rain or moisture, does not operate normally, or has been dropped.
15. This product may contain lead and mercury. Disposal of these materials may be regulated due to environmental considerations. For disposal or recycling information, please contact your local authorities or the Electronic Industries Alliance: www.eiae.org
16. **Damage Requiring Service** - The appliance should be serviced by qualified service personnel when:
 - A. The power supply cord or the plug has been damaged; or
 - B. Objects have fallen, or liquid has been spilled into the appliance; or
 - C. The appliance has been exposed to rain; or
 - D. The appliance does not appear to operate normally or exhibits a marked change in performance; or
 - E. The appliance has been dropped, or the enclosure damaged.
17. **Tilt/Stability** - All televisions must comply with recommended international global safety standards for tilt and stability properties of its cabinet design.
 - Do not compromise these design standards by applying excessive pull force to the front, or top, of the cabinet which could ultimately overturn the product.
 - Also, do not endanger yourself, or children, by placing electronic equipment/toys on the top of the cabinet. Such items could unsuspectingly fall from the top of the set and cause product damage and/or personal injury.
18. **Wall or Ceiling Mounting** - The appliance should be mounted to a wall or ceiling only as recommended by the manufacturer.
19. **Power Lines** - An outdoor antenna should be located away from power lines.
20. **Outdoor Antenna Grounding** - If an outside antenna is connected to the receiver, be sure the antenna system is grounded so as to provide some protection against voltage surges and built up static charges.

Section 810 of the National Electric Code, ANSI/NFPA No. 70-1984, provides information with respect to proper grounding of the mast and supporting structure, grounding of the lead-in wire to an antenna discharge unit, size of grounding connectors, location of antenna-discharge unit, connection to grounding electrodes, and requirements for the grounding electrode. See Figure below.
21. **Object and Liquid Entry** - Care should be taken so that objects do not fall and liquids are not spilled into the enclosure through openings.
22. **Battery Usage CAUTION** - To prevent battery leakage that may result in bodily injury, property damage, or damage to the unit:
 - Install all batteries correctly, with + and - aligned as marked on the unit.
 - Do not mix batteries (old and new or carbon and alkaline, etc.).
 - Remove batteries when the unit is not used for a long time.

Note to the CATV system installer: This reminder is provided to call the CATV system installer's attention to Article 820-40 of the NEC that provides guidelines for proper grounding and, in particular, specifies that the cable ground shall be connected to the grounding system of the building, as close to the point of cable entry as practical.

Example of Antenna Grounding as per NEC - National Electric Code

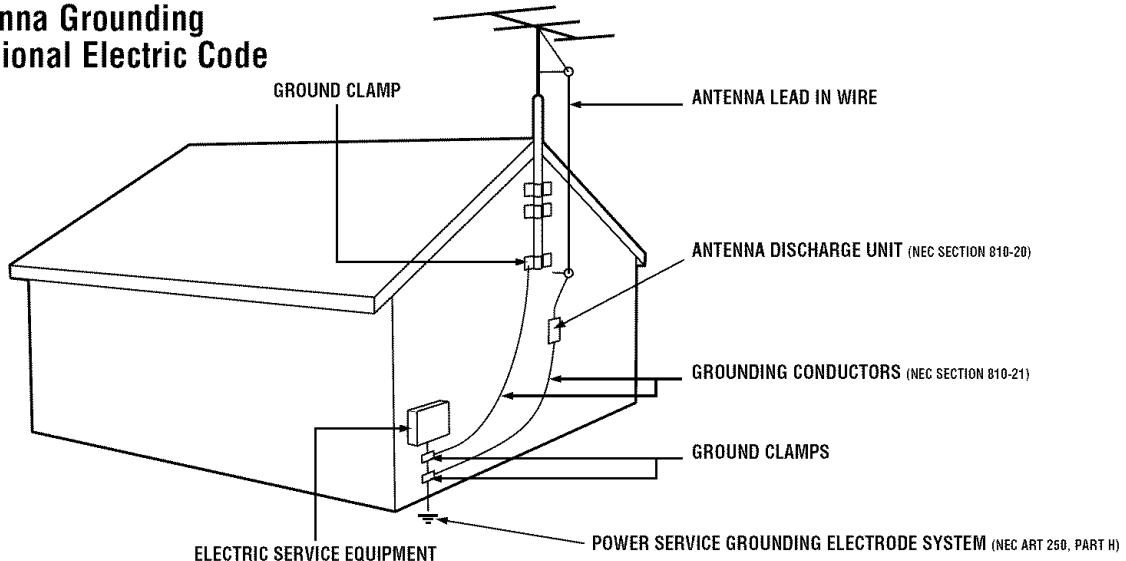

TABLE OF CONTENTS

Introduction

Welcome/Registration of Your TV	2
Safety Instructions	3
Table of Contents	4



Picture Menu

How to Use the Picture Adjustment Controls	5
How to use the DNR (Dynamic Noise Reduction) Control ..	6
How to use the Contrast + (Black Stretch) Control	7



Sound Menu

Using the Treble, Bass, and Balance Controls	8
How to Use the AVL Control	9
Setting the Incredible Surround Control	10
Setting the TV for SAP (Secondary Audio Programs)	11
Setting the TV to Receive Stereo Programming	12



Features Menu

Using the Timer Controls	13
Understanding the SmartLock Controls	14
Setting Up the SmartLock Access Code	15
How to Block Channels	16
How to Clear All Channels at the Same Time	17
How to Block All Channels at the Same Time	18
Blocking Programming Based on Movie Ratings	19
Blocking Programming Based on TV Ratings	20
Using the SmartLock Blocking Options	21
How to Use the Closed Captioning Control	22



Audio/Video Connections

Using the A/V Input Jacks	23
Using the Side A/V Input Jacks	23
Using the A/V Output Jacks	24
Using the S-Video Input Jack	25



Remote Control Use

Setting up the Sleptimer Option	26
Setting the SmartPicture	27
Setting SmartSound	28
Using the Surf Button (and Alternate Channel)	29
Remote Use with Accessory Devices (Direct Method) ..	30
Remote Use with Accessory Devices (Code Entry)	31
Remote Use with Accessory Devices (Search Method) ..	32
Remote Control Codes	33-34
Remote VCR Related Buttons	35



General Information

Troubleshooting, Care and Cleaning	36
Glossary of Terms	37
Index	37
Factory Service Locations	38-39
Warranty	40

Here are a few of the special features built into this new Color Television:

SmartLock™ feature allows you to block the viewing of certain channels or external audio/video connections where you might not want your children viewing inappropriate material.

Infrared Remote Control works your TV and allows you to program certain features with the press of one button. It can also be used with accessory devices such as VCRs, DVD Players, Cable Boxes, and more.

Audio/Video Jack panel for direct connections of accessory devices; Audio/Video Inputs and Outputs.

Standard broadcast (VHF/UHF) or Cable TV (CATV) channel capability.

Closed Captioning allows the viewer to read TV program dialog or voice conversations as on-screen text.

Automatic Programming of Channels for quick and easy selection of favorite stations available in your area.

On-screen Features (in either English or Spanish) show helpful messages for setting TV controls.

On Timer automatically turns the TV ON at a preset time and channel.

Sleptimer automatically turns the TV OFF at preset times.

SmartPicture™ allows you to set the picture's color, tint, contrast, etc., for various types of programming such as Sports, Movies, Personal, Weak Signals, or Multi Media with the push of one button.

SmartSound™ allows you to set the sound controls for various types of programs such as Personal (sound controls the way you set them), Theatre, Music, or Voice with the push of one button.

Treble, Bass, and Balance controls to enhance the television's sound.

NOTE: It is possible that this owner's manual may be used with several different television models. Not all features (and drawings) discussed in this manual will necessarily match those found with your television system. This is normal and does not require you contacting your dealer or requesting service.

How to Use the Picture Adjustment Controls



To adjust your TV picture controls, select a channel and follow the steps shown below:

- 1** Press the **MENU** button on the remote to display the on-screen menu.
- 2** Press the **▶** or **■** button until the word **PICTURE** is highlighted.
- 3** Press the **▶▶** button to display the **PICTURE** menu features.
- 4** Press the **▶** or **■** button to scroll the Picture features and highlight the control you wish to adjust (Brightness, Color, Picture, Sharpness, Tint, or Color Temp.).
- 5** Press the **▶▶** or **◀◀** button to adjust the selected control or to make selections for the Color Temp. control (Normal, Warm, or Cool).
- 6** Press the **▶** or **■** button to select and adjust other Picture Menu controls.
- 7** When finished, press the **STATUS /EXIT** button to remove the menu from the TV's screen.

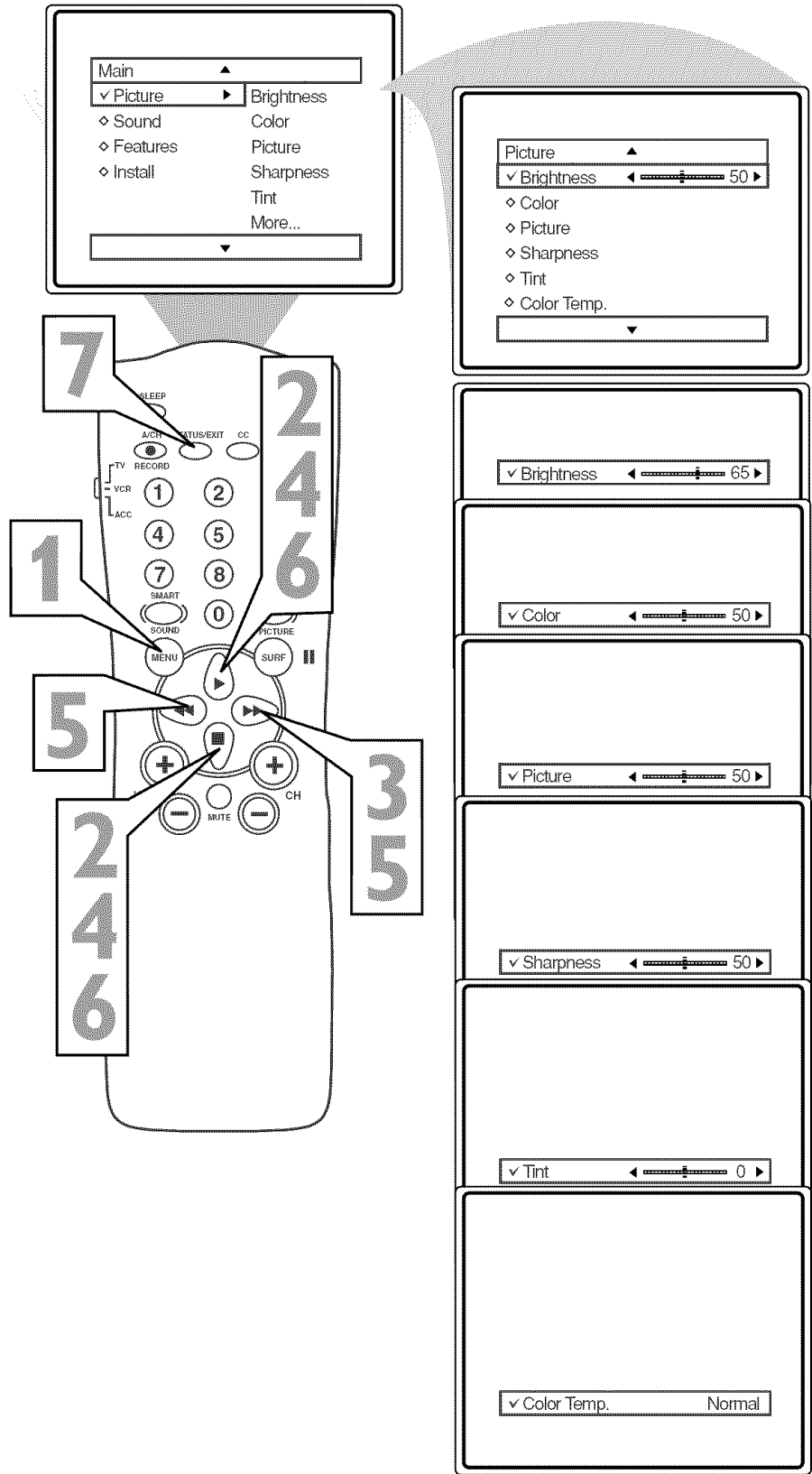

HELPFUL HINT

BRIGHTNESS Press the **▶▶** or **◀◀** buttons until the darkest parts of the picture are as bright as you prefer.

COLOR Press the **▶▶** or **◀◀** buttons to add or eliminate color.

PICTURE Press the **▶▶** or **◀◀** buttons until the lightest parts of the picture show good detail.

SHARPNESS Press the **▶▶** or **◀◀** buttons to improve detail in the picture.

TINT Press the **▶▶** or **◀◀** buttons to obtain natural skin tones.

COLOR TEMP Press the **▶▶** or **◀◀** buttons to select **NORMAL**, **COOL**, or **WARM** picture preferences. (**NORMAL** will keep the whites as white; **COOL** will make the whites more blue; and **WARM** will make the whites more red.)

Warm
or
Cool

How to Use the DNR (Noise Reduction) Control

For reasons such as poor cable reception, the picture can sometimes appear slightly "speckled" (or has signal noise shown in the picture). The DNR (Dynamic Noise Reduction) control can help eliminate this type of interference and improve the quality of the picture.

- 1** Press the **MENU** button on the remote to display the on-screen menu.
- 2** Press the **▶** or **■** button until the word **PICTURE** is highlighted.
- 3** Press the **▶▶** button to display the **PICTURE** menu features.
- 4** Press the **▶** or **■** button to scroll the Picture menu features until the word **DNR** is highlighted.
- 5** Press the **▶▶** button to turn the **DNR** feature ON or OFF.
- 6** When finished, press the **STATUS /EXIT** button to remove the menu from the TV's screen.

HELPFUL HINT

Noise Reduction is a video adjustment feature that affects the picture quality of the TV, not the sound.

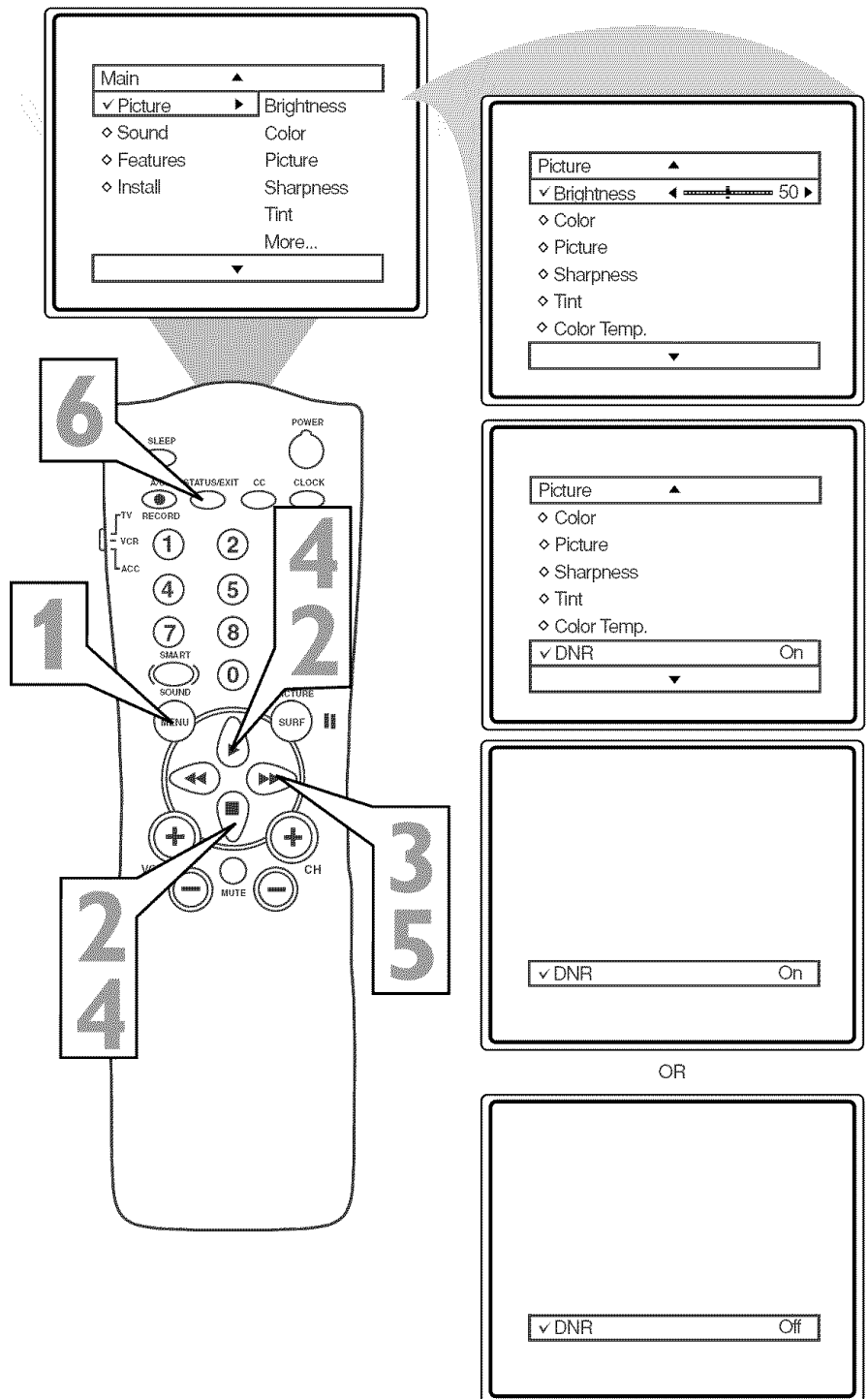

HOW TO USE THE CONTRAST + (BLACK STRETCH) CONTROL



The Contrast + (Black Stretch) control helps to “sharpen” the picture quality. The black portions of the picture become richer in darkness and the whites become brighter.

- 1** Press the **MENU** button on the remote to display the on-screen menu.
- 2** Press the **▶** or **■** button until the word **PICTURE** is highlighted.
- 3** Press the **▶▶** button to display the **PICTURE** menu features.
- 4** Press the **▶** or **■** button to scroll the Picture menu features until the word **CONTRAST +** is highlighted.
- 5** Press the **▶▶** button to turn the **CONTRAST +** feature ON or OFF.
- 6** When finished, press the **STATUS /EXIT** button to remove the menu from the TV’s screen.

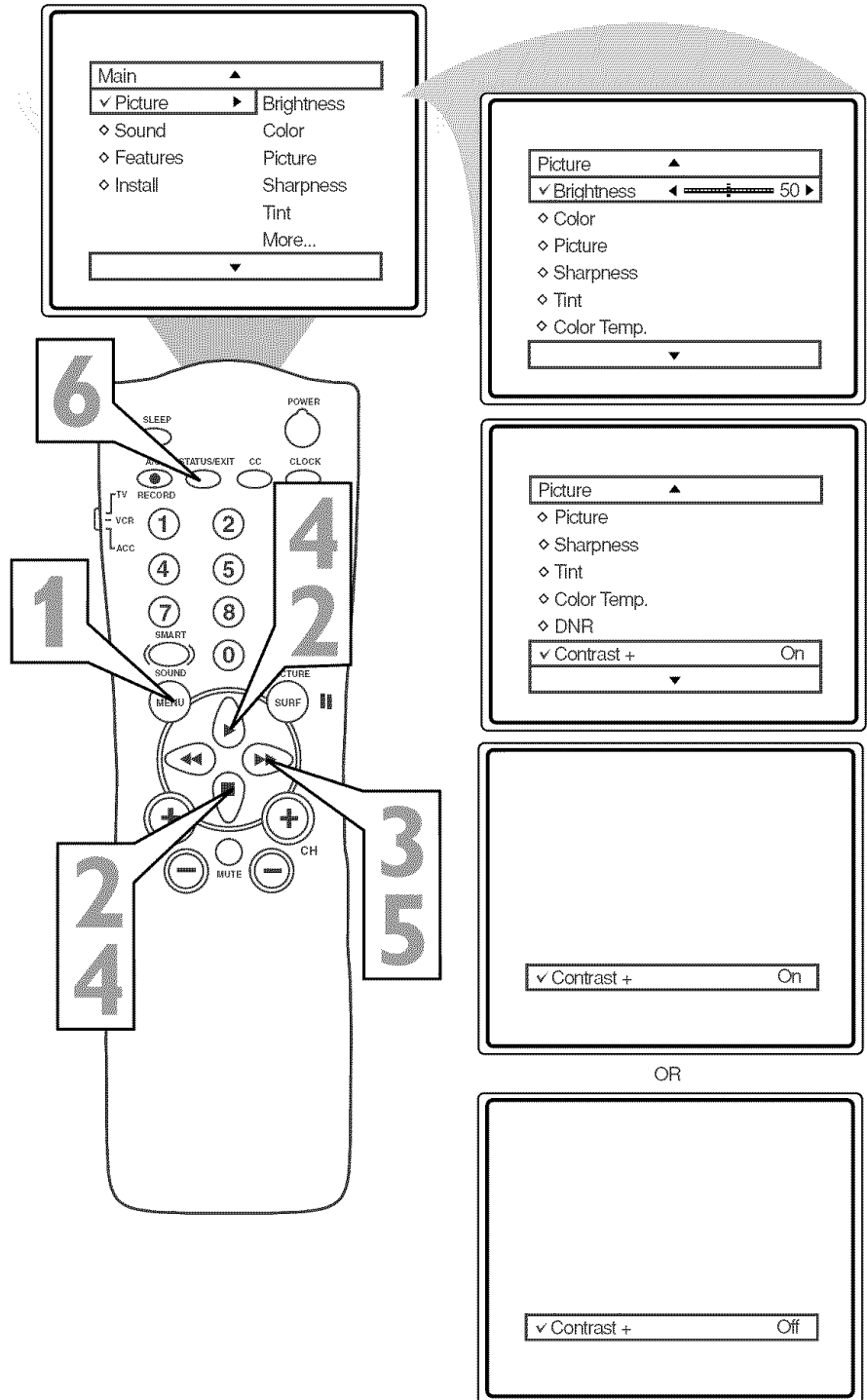



How to Adjust the Bass, Treble, Balance Controls

Besides the normal volume control, your TV also has Bass, Treble, and Balance sound controls. The **TREBLE** control affects the high frequency sounds coming from the TV, enhancing the highs. The **BASS** control affects the low frequency sounds coming from the TV, enhancing the lows. The **BALANCE** control adjusts the sound level being heard from each speaker.

- 1** Press the **MENU** button on the remote to display the on-screen menu.
- 2** Press the **▶** or **■** button until the word **SOUND** is highlighted.
- 3** Press the **▶▶** button to display the **SOUND** menu features.
- 4** Press the **▶** or **■** button to scroll the Sound menu features until **TREBLE**, **BASS**, or **BALANCE** is highlighted.
- 5** Press the **▶▶** or **◀◀** button to adjust the **Treble**, **Bass**, or **Balance** controls.
- 6** When finished, press the **STATUS /EXIT** button to remove the menu from the TV's screen.

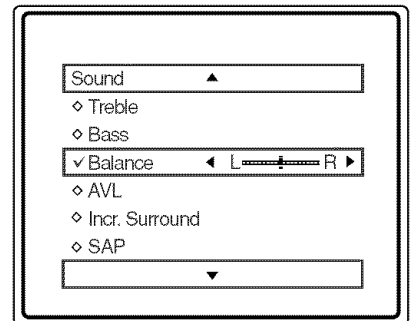
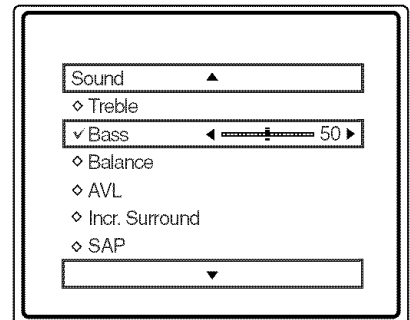
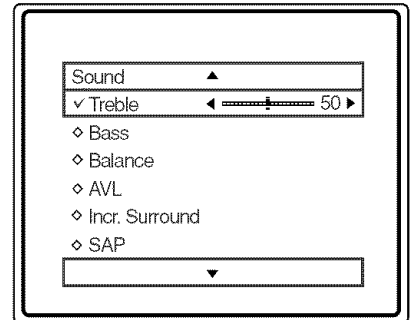
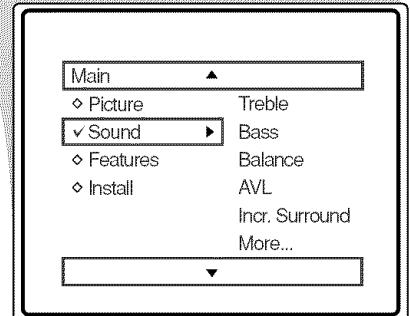
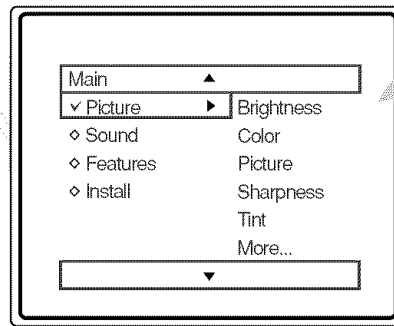
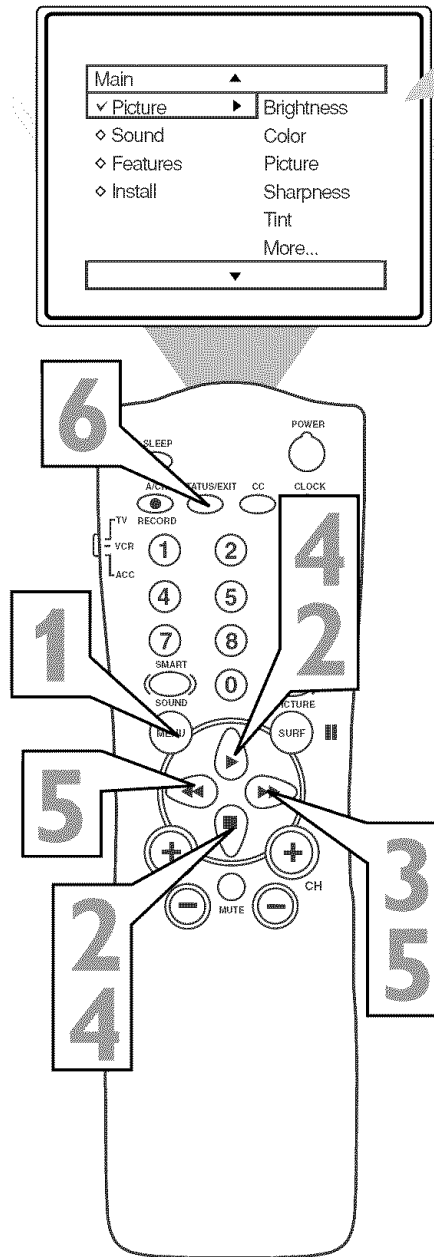

How to Use the AVL (AUTOMATIC VOLUME LEVELER) CONTROL

In most cases, the volume levels coming from broadcast programming or commercials are never the same. With AVL (Automatic Volume Leveler) ON, you can have the TV level out the sound. This provides a more consistent sound by reducing the peaks and valleys that occur during program changes or commercial breaks. To turn on AVL, follow these steps.

- 1** Press the **MENU** button on the remote to display the on-screen menu.
- 2** Press the **▶** or **■** button until the word **SOUND** is highlighted.
- 3** Press the **▶▶** button to display the **SOUND** menu features.
- 4** Press the **▶** or **■** button to scroll the Sound menu features until the word **AVL** is highlighted.
- 5** Press the **▶▶** button to turn the AVL control ON or OFF.
- 6** When finished, press the **STATUS /EXIT** button to remove the menu from the TV's screen.

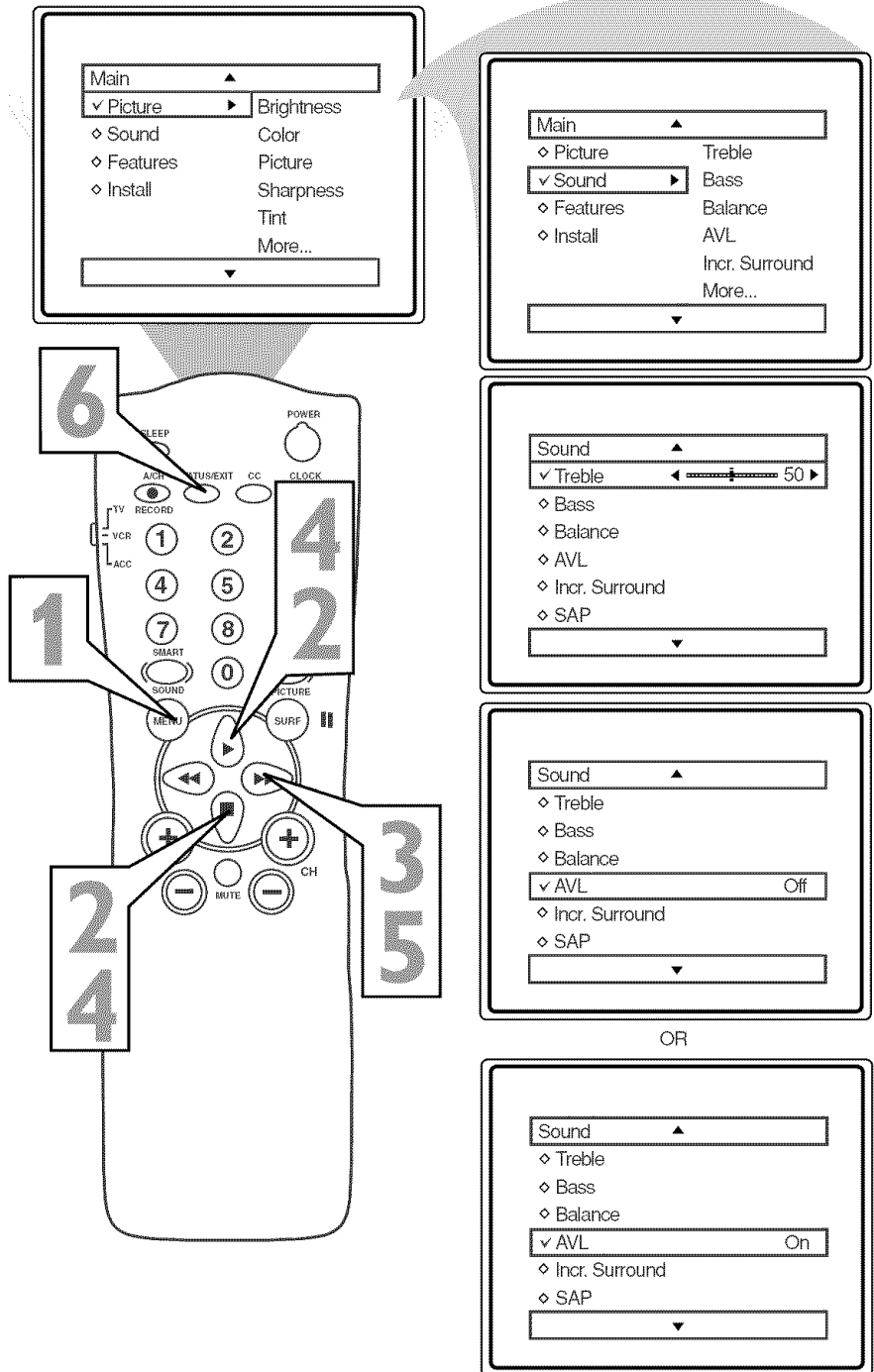



SETTING THE INCREDIBLE SURROUND CONTROL

The Incredible Surround feature adds greater depth and dimension to both monaural (MONO) and stereo TV sound. With the control turned ON, the TV speakers can widen the sound separation of normal broadcasts.

- 1 Press the **MENU** button on the remote to display the on-screen menu.
- 2 Press the **▶** or **■** button until the word **SOUND** is highlighted.
- 3 Press the **▶▶** button to display the **SOUND** menu features.
- 4 Press the **▶** or **■** button to scroll the Sound menu features until the words **INCR. SURROUND** are highlighted.
- 5 Press the **▶▶** button to set the **Incredible Surround** control as follows:

MONO: When in Mono Sound Mode, set Incredible Surround to Mono or Spatial.

STEREO: When in Stereo Sound Mode, set Incredible Surround to Stereo or Incredible Surround.

- 6 When finished, press the **STATUS /EXIT** button to remove the menu from the TV's screen.

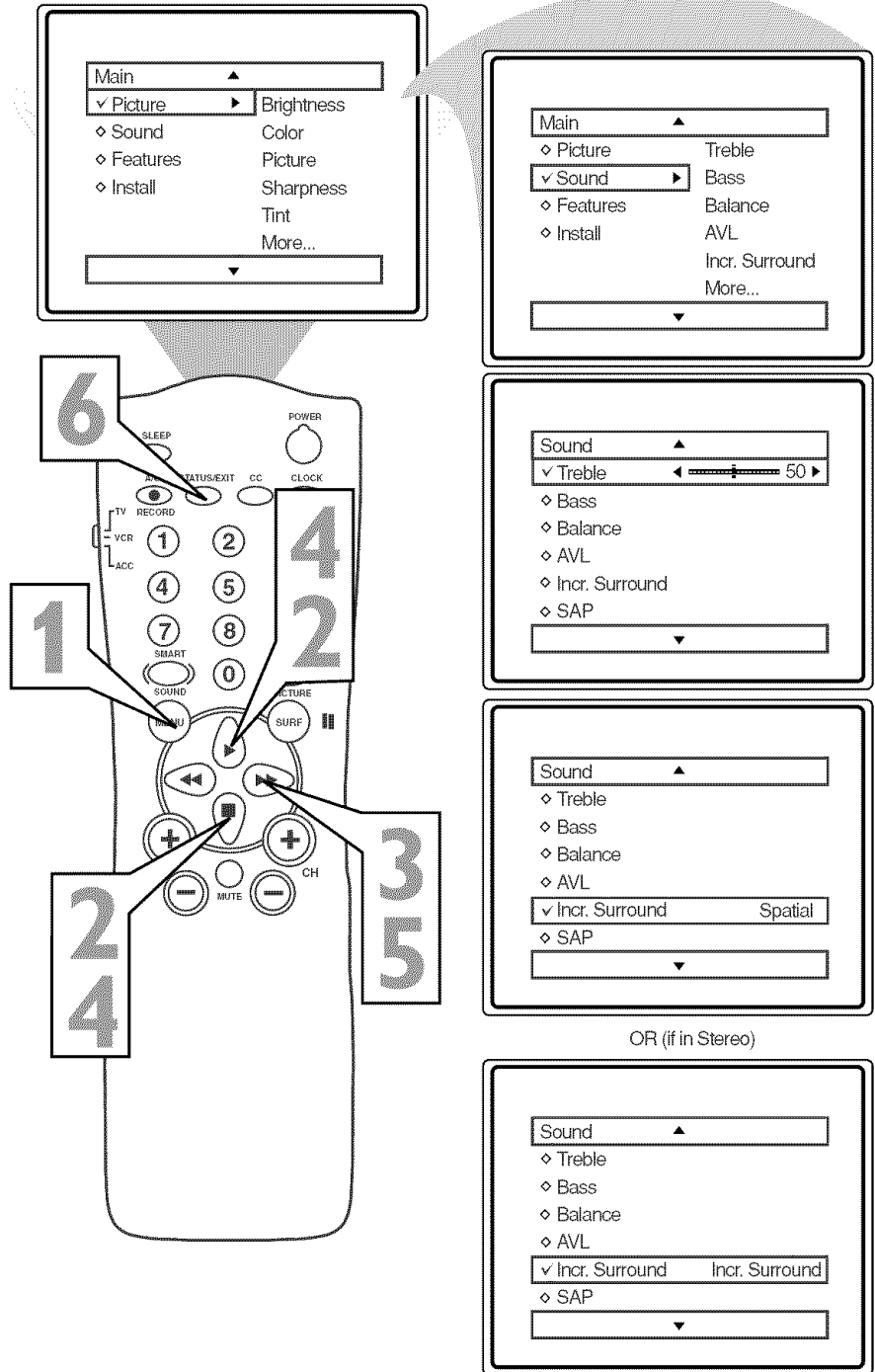

HELPFUL HINT

NOTE: If the TV program is broadcast in Mono sound, pressing the INCR. SURR. button will cause MONO or SPATIAL to appear on the screen. If the program is broadcast in Stereo and "SOUND" is set to Stereo (see page 12), pressing INCR. SURR. will choose STEREO or INCR. SURROUND.

SPATIAL – Widens the Monaural/Mono sound and simulates a broader, fuller sound.

INCR. SURROUND – Widens the Stereo sound and simulates a broader, fuller sound.

SETTING THE TV FOR SAP (SECONDARY AUDIO PROGRAMS)

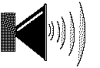

An SAP signal is an additional part of the stereo broadcast system. Sent as a third audio channel, an SAP signal can be heard apart from the current TV program sound. TV stations are free to use SAP for any number of purposes.

If an SAP signal is not present with a selected program, the SAP option cannot be selected. Also, if SAP is selected on a channel (with SAP) and you select another channel, when you return to the original channel, SAP will be OFF. You will have to reselect the SAP feature.

- 1** Press the **MENU** button on the remote to display the on-screen menu.
- 2** Press the **▶** or **■** button until the word **SOUND** is highlighted.
- 3** Press the **▶▶** button to display the **SOUND** menu features.
- 4** Press the **▶** or **■** button to scroll the Sound menu features until **SAP** is highlighted.
- 5** Press the **▶▶** button to turn the SAP control ON or OFF.
- 6** When finished, press the **STATUS/EXIT** button to remove the menu from the TV's screen.

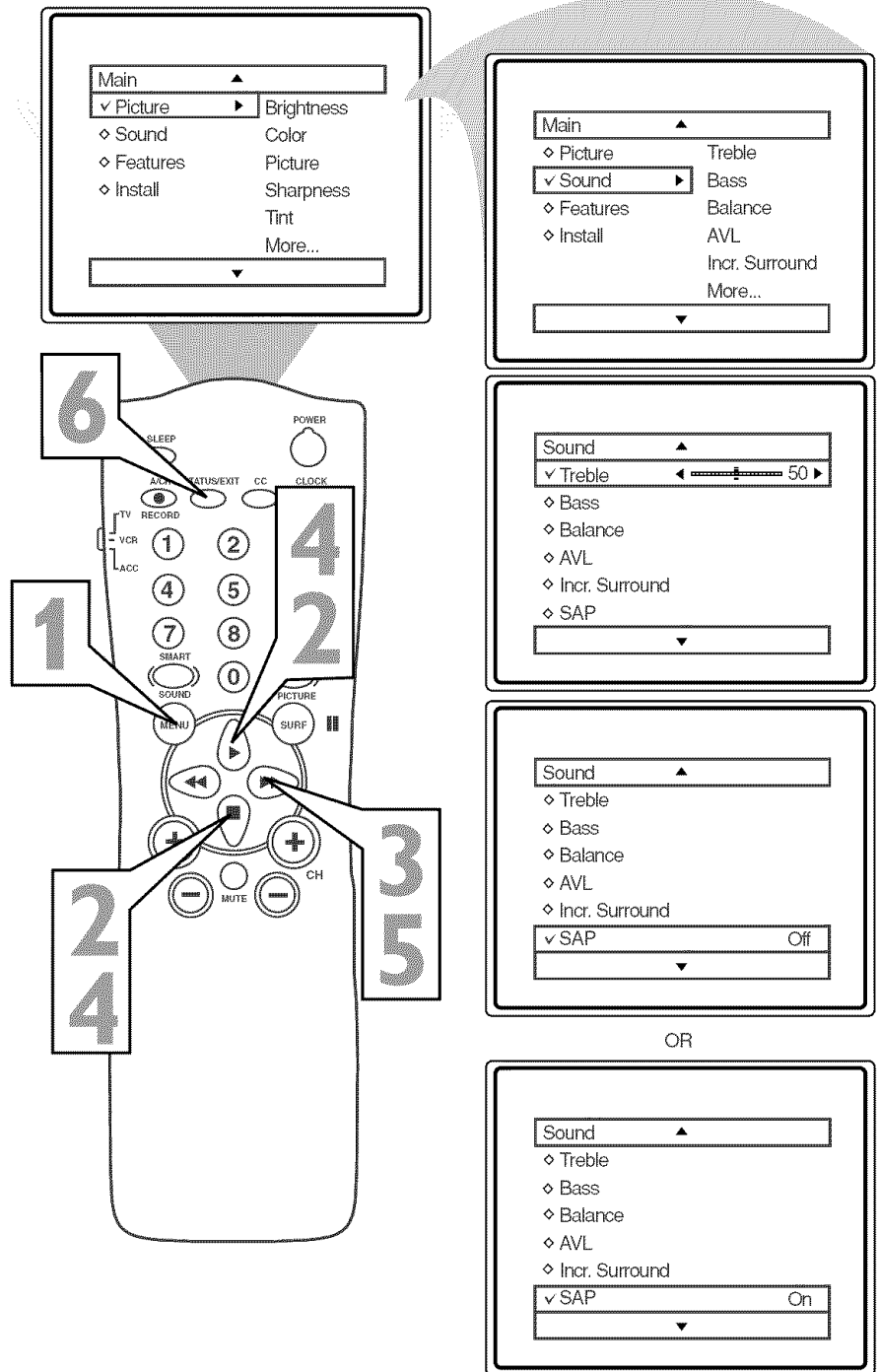

Note: If SAP is not present on the current channel, when SAP is ON the screen will read:

“SAP NOT AVAILABLE.”



SETTING THE TV TO RECEIVE STEREO PROGRAMMING

You can receive broadcast stereo TV programs. The TV has both an amplifier and twin speakers through which the stereo sound can be heard.

- 1** Press the **MENU** button on the remote to display the on-screen menu.
- 2** Press the **▶** or **■** button until the word **SOUND** is highlighted.
- 3** Press the **▶▶** button to display the **SOUND** menu features.
- 4** Press the **▶** or **■** button to scroll the Sound menu features until the word **SOUND** is highlighted.
- 5** Press the **▶▶** button to set the Sound control to Mono or Stereo.
- 6** When finished, press the **STATUS/EXIT** button to remove the menu from the TV's screen.

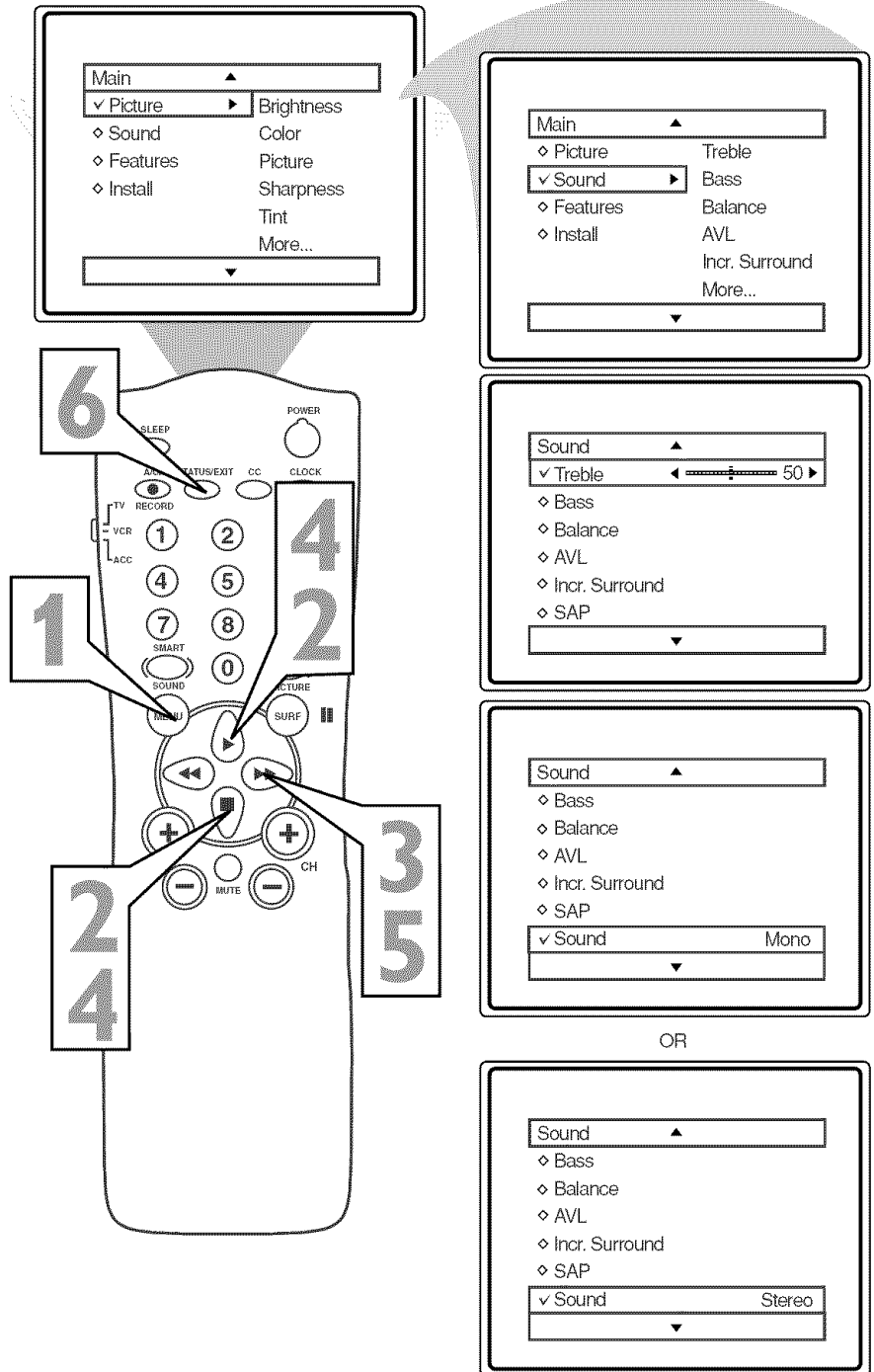

HELPFUL HINT

Remember, if stereo is not present on a selected show, the Sound control cannot be changed to Stereo. On the other hand, if stereo is present on a selected show, the Sound control can be set to Mono.

When channel changes are made, the screen may indicate Mono for a second or two, then change to Stereo if the signal being received is in stereo.

HOW TO USE THE TIMER CONTROLS



The Timer controls allow you to use your TV as an alarm clock to turn itself on and off at a specific time. It also can be set to tune to a specific channel at a specific time.

- 1** Press the **CLOCK** button on the remote. The Timer menu will appear on the screen.
- 2** Press the **▶** or **■** button to highlight one of the Timer controls you wish to set (Time, Start Time, Stop Time, Channel, Activate, or Display).
- 3** Press the **▶▶** button to adjust the selected option.

TIME: Enter the current time with the Number buttons. Use the **▶▶** button to move to the AM/PM area and use **▶** or **■** to choose AM or PM.

START TIME: Use the Number buttons to enter a start-up time for the TV to turn on or to tune to a specific channel.

STOP TIME: Use the Number buttons to enter a time for the TV to shut off.

CHANNEL: Use the Number buttons or the CH + or - buttons to select a specific channel for the TV to tune to at the specific Start Time.

ACTIVATE: Set the Timer to perform its function ONCE or DAILY.

DISPLAY: Choose ON if you want the time to show on the screen when the TV is on. Choose OFF to see the time only when you press STATUS/EXIT.

- 4** When finished, press the **STATUS /EXIT** button to remove the menu from the TV's screen.

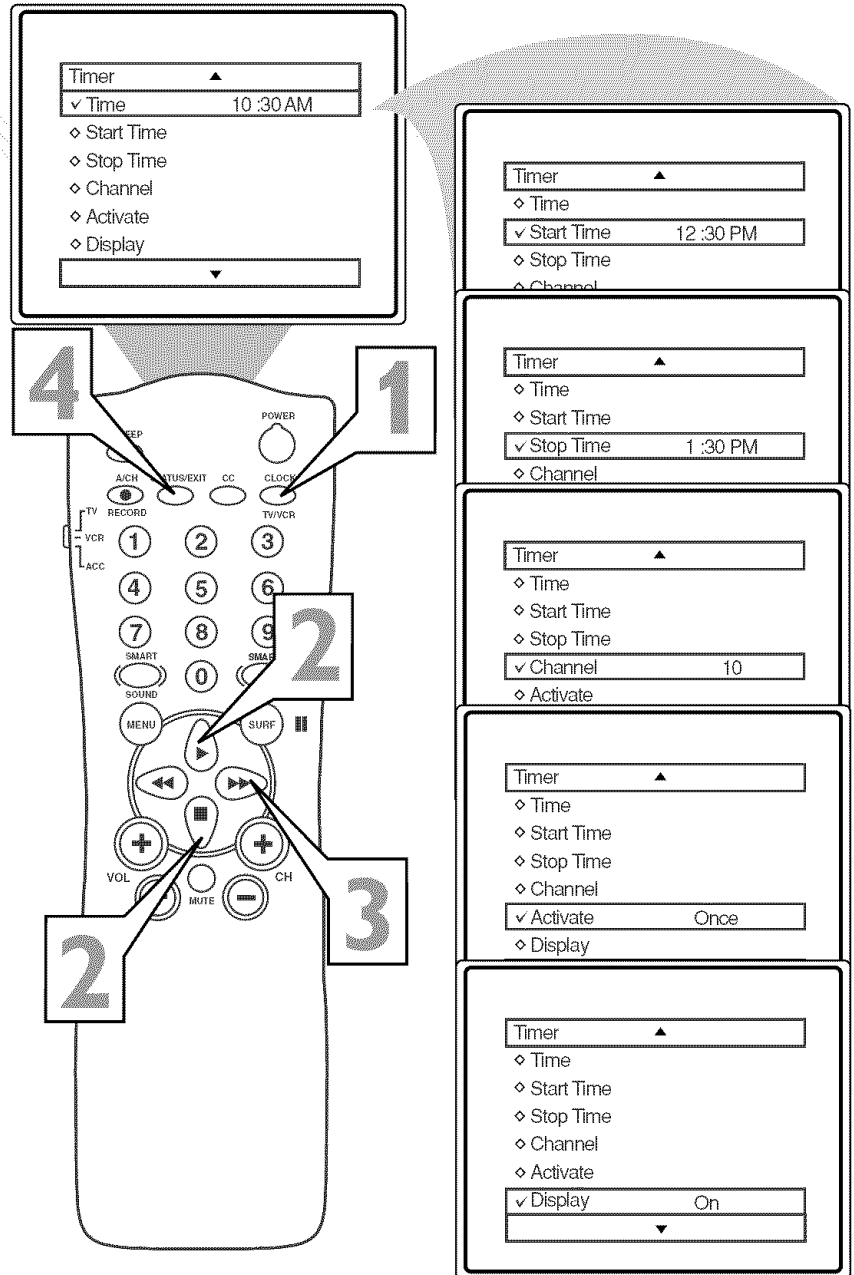



UNDERSTANDING THE SMARTLOCK CONTROLS

SmartLock receives and processes data sent by broadcasters that contains program content advisories. When programmed by the viewer, a TV with SmartLock can respond to the content advisories and block objectionable program content (offensive language, violence, sexual situations, etc.). This is a great feature to censor the type of viewing children may watch.

Over the next few pages you'll learn how to block channels and certain rated programming. Below is a brief explanation of some terms and ratings you will find in the SmartLock feature.

SmartLock offers various BLOCKING controls:

Access Code: An Access Code must be set to prevent children from unblocking questionable or censored programming.

Block Channel: After an access code has been programmed, you can block individual channels, including the Audio/Video inputs.

Clear All: Allows you clear all channels blocked by Channel Block.

Block All: Allows you to block ALL channels and Audio/Video inputs at one time.

Movie Ratings: Block programming based on ratings of the Motion Pictures Association of America.

TV Ratings: Just like the Movie Ratings, block viewing using standard TV ratings set by TV broadcasters.

To learn more about the ratings of the Motion Pictures Association of America and TV Broadcasters, refer to the definitions at right.

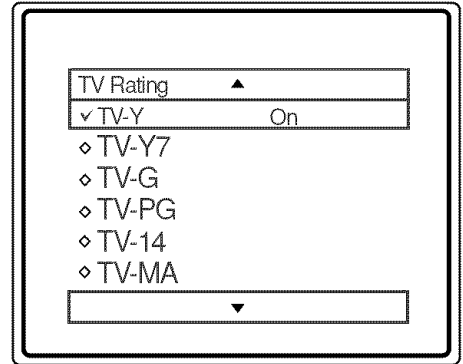
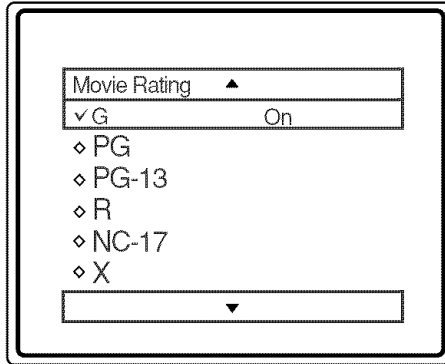

MOVIE RATINGS (MOTION PICTURES ASSOCIATION OF AMERICA)

G: General Audience - All ages admitted. Most parents would find this programming suitable for all ages. This type of programming contains little or no violence, no strong language, and little or no sexual dialog or situations.

PG: Parental Guidance Suggested - This programming contains material that parents may find unsuitable for younger children. It may contain one or more of the following: Moderate violence, some sexual situations, infrequent coarse language, or some suggestive dialog.

PG-13: Parents Strongly Cautioned - This programming contains material that parents may find unsuitable for children under the age of 13. It contains one or more of the following: violence, sexual situations, coarse language, or suggestive dialog.

R: Restricted - This programming is specifically designed for adults. Anyone under the age of 17 should only view this programming with an accompanying parent or adult guardian. It contains one or more of the following: intense violence, intense sexual situations, strong coarse language, or intensely suggestive dialog.

NC-17: No one under the age of 17 will be admitted. - This type of programming should be viewed by adults only. It contains graphic violence, explicit sex, or crude indecent language.

X: Adults Only - This type of programming contains one or more of the following: very graphic violence, very graphic and explicit or indecent sexual acts, very coarse and intensely suggestive language.

TV PARENTAL GUIDELINES (TV BROADCASTERS)

TV-Y **TV-Y** - (All children -- This program is designed to be appropriate for all children.) Designed for a very young audience, including children ages 2-6. This type of programming is not expected to frighten younger children.

TV-Y7 **TV-Y7** - (Directed to Older Children -- This program is designed for children age 7 and above.) It may be more appropriate for children who have acquired the development skills needed to distinguish between make-believe and reality. This programming may include mild fantasy and comic violence (FV).

TV-G **TV-G** - (General Audience -- Most parents would find this program suitable for all ages.) This type of programming contains little or no violence, no strong language, and little or no sexual dialog or situations.

TV-PG **TV-PG** - (Parental Guidance Suggested -- This program contains material that parents may find unsuitable for younger children.) This type of programming contains one or more of the following: Moderate violence (V), some sexual situations (S), infrequent coarse language (L), or some suggestive dialog (D).

TV-14 **TV-14** - (Parents Strongly Cautioned -- This program contains some material that many parents would find unsuitable for children under 14 years of age.) This type of programming contains one or more of the following: intense violence (V), intense sexual situations (S), strong coarse language (L), or intensely suggestive dialog (D).

TV-MA **TV-MA** - (Mature Audience Only -- This program is specifically designed to be viewed by adults and therefore may be unsuitable for children under 17.) This type of programming contains one or more of the following: graphic violence (V), explicit sexual situations (S), or crude indecent language (L).

SETTING UP THE SMARTLOCK ACCESS CODE



Over the next few pages you'll learn how to block channels and get a better understanding of the rating terms for certain programming.

First, let's start by learning how to set a personal access code:

- 1** Press the **MENU** button on the remote to display the on-screen menu.
- 2** Press the **▶** or **■** button until the word **FEATURES** is highlighted.
- 3** Press the **▶▶** button to display the **FEATURES** menu options.
- 4** Press the **▶** or **■** button until **SMARTLOCK** is highlighted.
- 5** Press the **▶▶** button. The screen will read "ACCESS CODE - - - -."
- 6** Using the **Number** buttons, enter **0, 7, 1, 1**. "XXXX" appears on the Access Code screen as you press the **Number** buttons.
"INCORRECT CODE" will appear on the screen, and you will need to enter **0, 7, 1, 1** again.
- 7** The screen will ask you to enter a **New Code**. Enter a "new" four-digit code using the **Number** buttons. The screen will then ask you to **CONFIRM** the code you just entered. Enter your **new code** again. "XXXX" will appear when you enter your new code and then display the **SmartLock** menu options.

Proceed to the next page to learn more...

HELPFUL HINT

Parents - it isn't possible for your child to unblock a channel without knowing your access code or changing it to a new one. If your code changes, and you didn't change it, then you know it's been altered by someone else and blocked channels have been viewed.

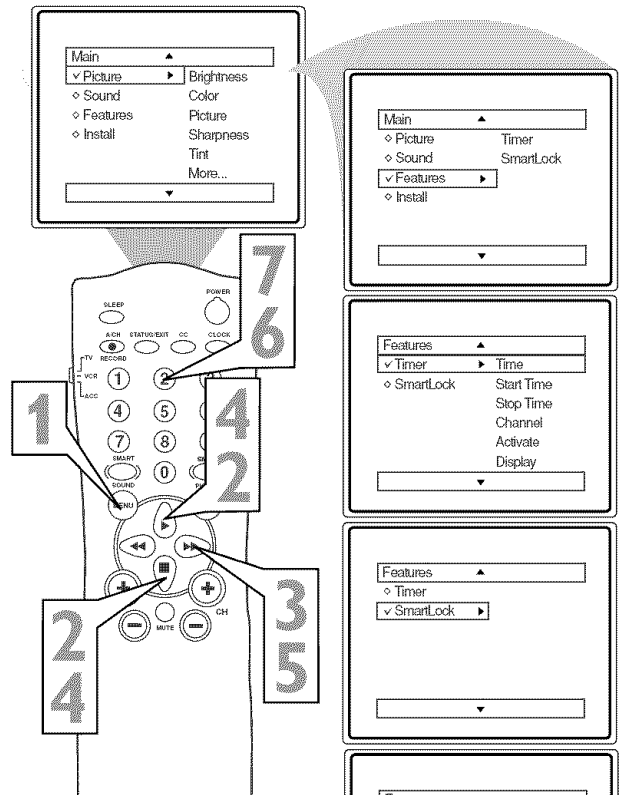

NOTE: The 0,7,1,1 access code is the default code or a way to reset the code when the current access code is not known.

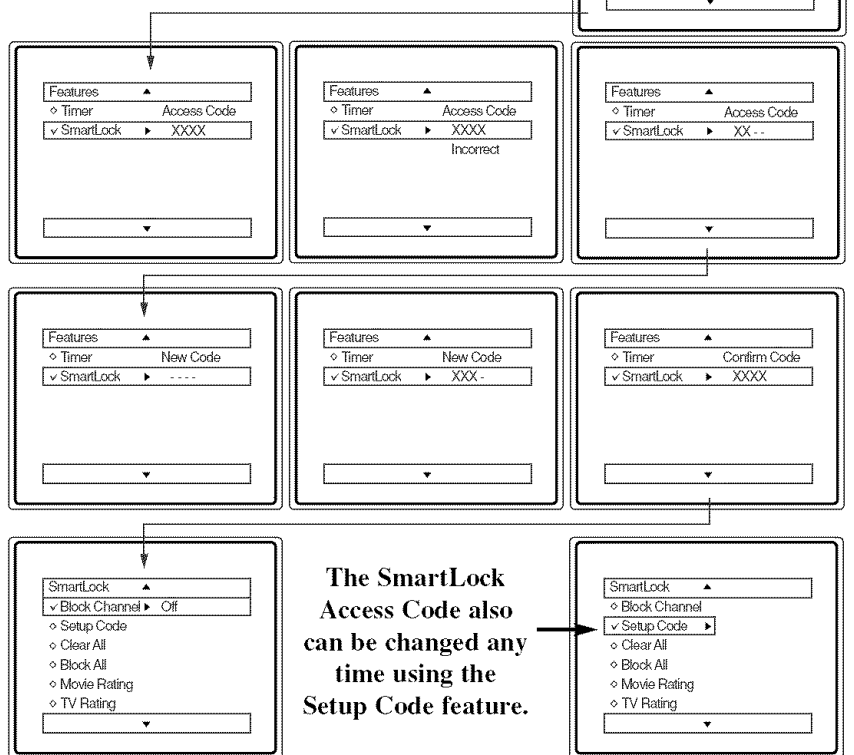



How to BLOCK CHANNELS

After your personal access code has been set (see previous page), you are now ready to select the channels or Audio/Video Inputs you want to block out or censor.

- 1 Press the **Number** (or **CH +, -**) buttons to select the channel you wish to block or censor.
- 2 Press the **MENU** button on the remote to show the on-screen menu.
- 3 Press the **▶** or **■** button until the word **FEATURES** is highlighted.
- 4 Press the **▶▶** button to enter the **FEATURES** menu.
- 5 Press the **▶** or **■** button until **SMARTLOCK** is highlighted.
- 6 Press the **▶▶** button.
- 7 Enter the correct access code. "XXXX" shows on the Access Code display as you press the **Number** buttons. SmartLock menu options will be displayed.
- 8 Press the **▶** or **■** buttons until **BLOCK CHANNEL** is highlighted.
- 9 Press the **▶▶** button to turn blocking ON or OFF for that channel. When ON is selected the channel will be blocked.
- 10 Press the **CH +** or **-** button to select other channels you wish to block. Repeat step 9 to block the new channel.

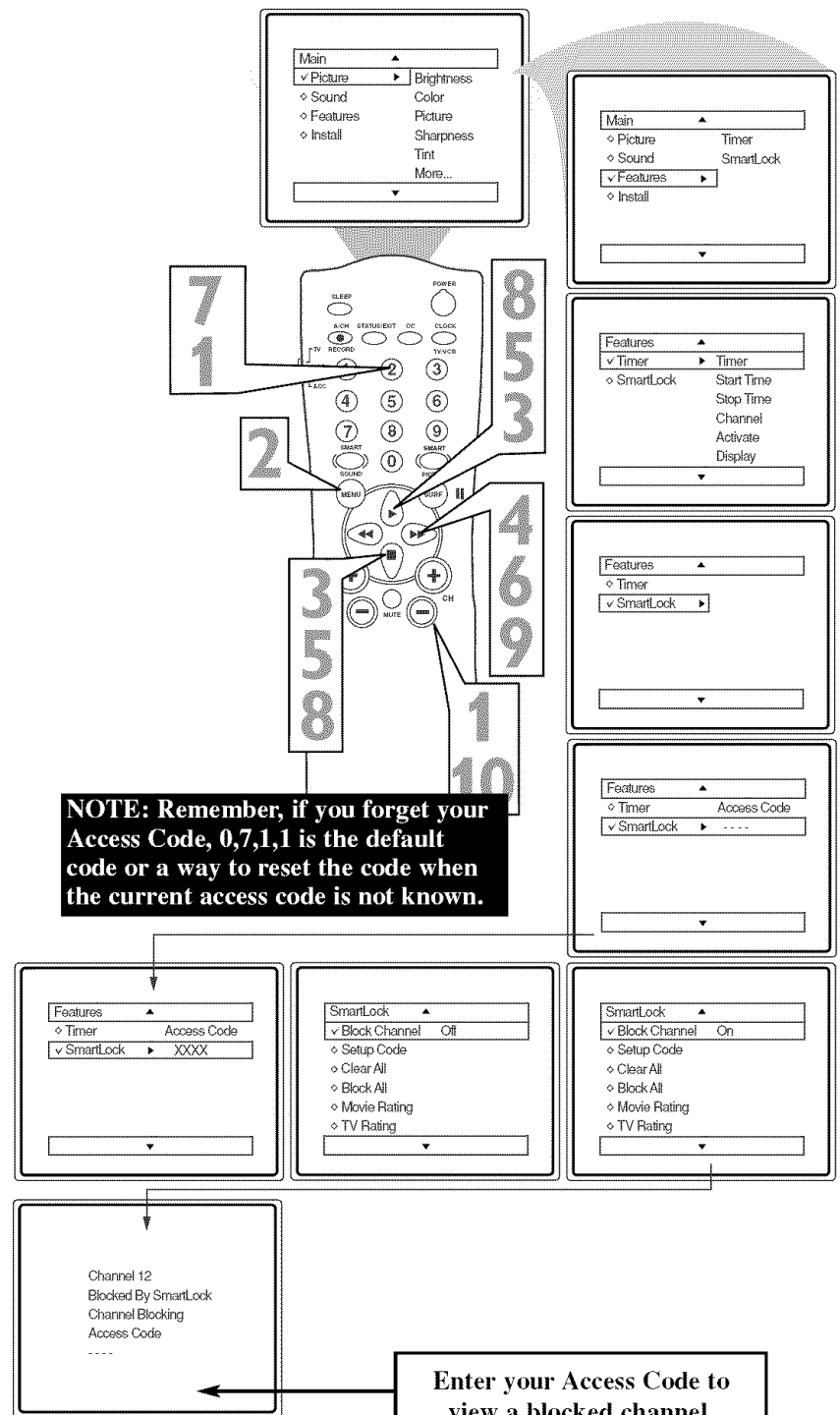

HELPFUL HINT

If you tune to a blocked channel and enter your Access Code to view the channel, ALL blocked channels will be viewable until the TV has been turned off. When the TV is powered back ON, the previously blocked channels will be blocked again.

HOW TO CLEAR ALL BLOCKED CHANNELS AT THE SAME TIME



After blocking specific channels, you may want to clear all the channels for viewing. The following steps explain how to CLEAR ALL blocked channels.

- 1** Press the **MENU** button on the remote to show the on-screen menu.
- 2** Press the **▶** or **■** button until the word **FEATURES** is highlighted.
- 3** Press the **▶▶** button to display the FEATURES menu options.
- 4** Press the **▶** or **■** button until SmartLock is highlighted.
- 5** Press the **▶▶** button.
- 6** Enter the correct access code. "XXXX" shows on the Access Code display as you press the **Number** buttons. SmartLock menu options will be displayed.
- 7** Press the **▶** or **■** button until the words **CLEAR ALL** are highlighted.
- 8** Press the **▶▶** button to clear all blocked channels. The Clear All option will read "Cleared."
- 9** When finished, press the **STATUS /EXIT** button to remove the menu from the TV's screen.

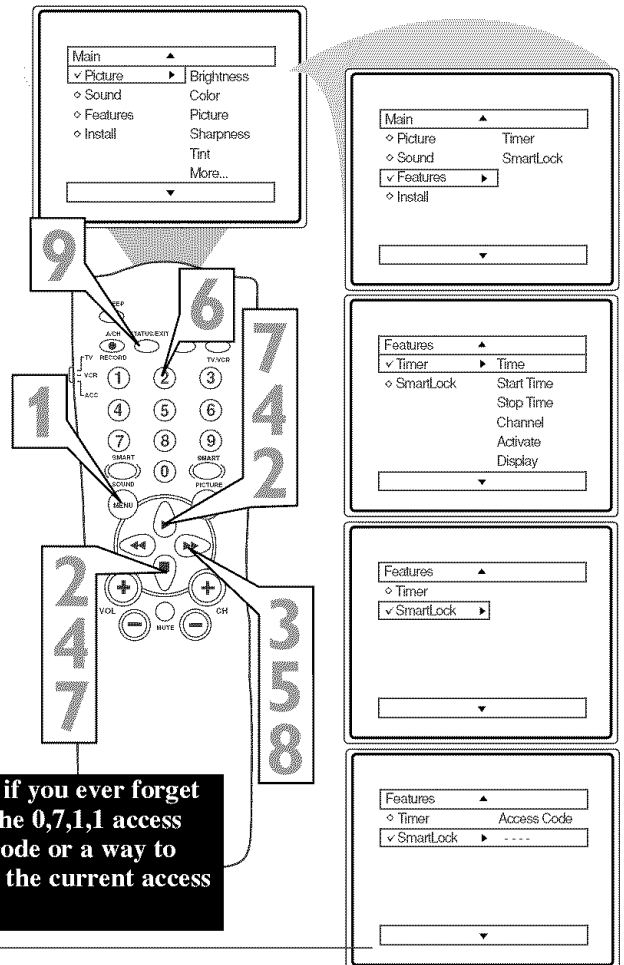

NOTE: Remember, if you ever forget your Access Code, the 0,7,1,1 access code is the default code or a way to reset the code when the current access code is not known.

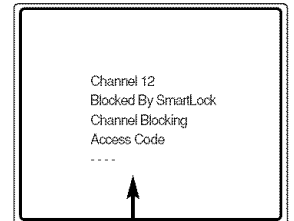
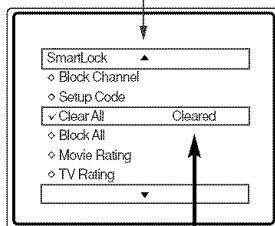
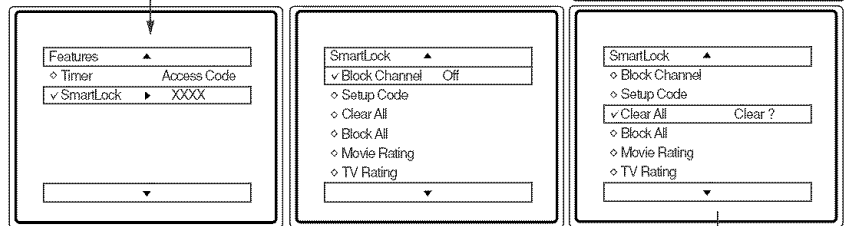

Or, enter your Access Code to view a blocked channel.

HELPFUL HINT
If you tune to a blocked channel and enter your Access Code to view the channel, ALL blocked channels will be viewable until you turn off the TV. When you turn on the TV again, channels will be blocked again.

The Clear All option will unblock ALL blocked channels. It will not affect programming blocked by the Movie or TV Rating options.



How to Block All Channels at the Same Time

There may come a time when you want to Block All the television's channels. Maybe you don't want your children to watch TV for a given time. With the Block All control, ALL available channels (including the Audio/Video Inputs) can be blocked at the same time.

- 1 Press the **MENU** button on the remote to show the on-screen menu.
- 2 Press the **▶** or **■** button until the word **FEATURES** is highlighted.
- 3 Press the **▶▶** button to display the FEATURES menu options.
- 4 Press the **▶** or **■** button until SmartLock is highlighted.
- 5 Press the **▶▶** button.
- 6 Enter the correct access code. "XXXX" shows on the Access Code display as you press the **Number buttons**. SmartLock menu options will be displayed.
- 7 Press the **▶** or **■** button until the words **BLOCK ALL** are highlighted.
- 8 Press the **▶▶** button to turn Block All ON or OFF. When ON is selected, ALL available channels will be blocked.
- 9 When finished, press the **STATUS/EXIT** button to remove the menu from the screen.

HELPFUL HINT

If you tune to a blocked channel and enter your Access Code to view the channel, ALL blocked channels will be viewable until you turn off the TV. When you turn on the TV again, channels will be blocked again.

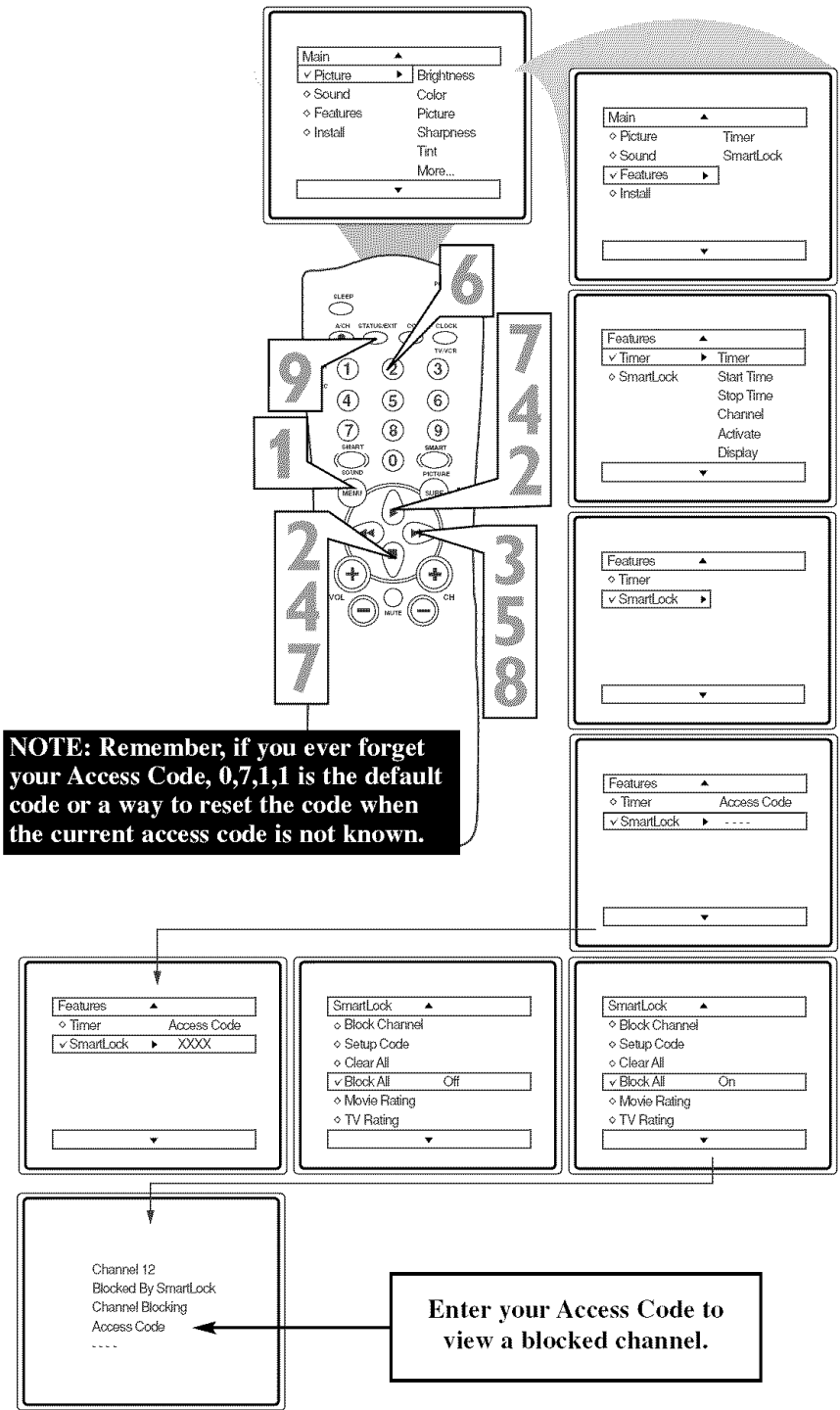

BLOCKING PROGRAMMING BASED ON MOVIE RATINGS



There are two types of program ratings within the SmartLock feature. One is based on the Movie Industry ratings, while the other is based on the TV Industry ratings. Both can be used to block or censor programming.

Let's first look at the Movie Rating options of SmartLock:

- 1 Press the **MENU** button on the remote to display the on-screen menu.
- 2 Press the **▶** or **■** button until the word **FEATURES** is highlighted.
- 3 Press the **▶▶** button to display the **FEATURES** menu options.
- 4 Press the **▶** or **■** button until **SmartLock** is highlighted.
- 5 Press the **▶▶** button. The screen will prompt you for your Access Code.
- 6 Using the **Number** buttons on the remote, enter your four-digit Access Code. The SmartLock menu options will be displayed.
- 7 Press the **▶** or **■** button to highlight the words **MOVIE RATING**.
- 8 Press the **▶▶** button to display the **MOVIE RATING** options (G, PG, PG-13, R, NC17, or X).
- 9 Press the **▶** or **■** button to highlight any of the Movie Ratings options. When highlighted, all these options can be turned **ON** (which will allow blocking) or **OFF** (which will allow viewing).
- 10 Use the **▶▶** button on the remote to turn the rating option ON or OFF.

HELPFUL HINT

When a rating is set to block, all higher ratings will be blocked as well. (Example: If the PG-13 rating is set to block, the R, NC-17, and X ratings will also be blocked.)

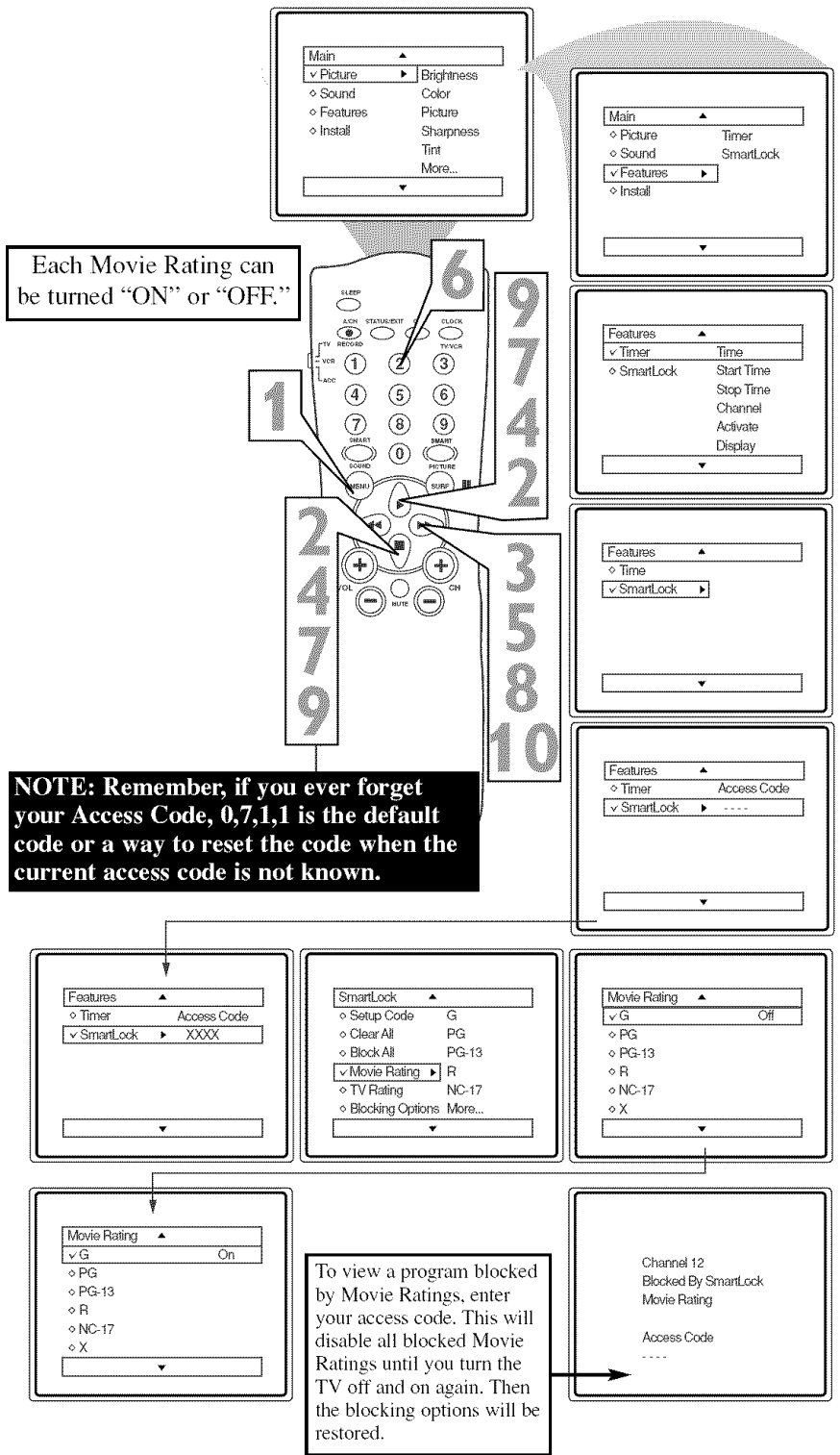



BLOCKING PROGRAMMING BASED ON TV RATINGS

This portion of SmartLock covers TV Ratings. After selecting SmartLock and entering your personal access code, the SmartLock options screen appears.

- 1** Scroll the menu using the **▶** or **■** button until the words **TV RATING** are highlighted.
- 2** Press the **▶▶** button to display the **TV Ratings (TV-Y, TV-Y7, TV-G, TV-PG, TV-14, or TV-MA)**. When highlighted, TV-Y and TV-G can be turned **ON** (to block viewing) or **OFF** (to allow viewing).
The ratings of TV-Y7, TV-PG, TV-14, and TV-MA can be customized to block V (violence), FV (fantasy violence), S (sexual situations), L (coarse language), or D (suggestive dialog).
- 3** Press the **▶** or **■** button to highlight the desired rating.
- 4** Press the **▶▶** button to turn TV-Y or TV-G ON or OFF. Or, press the **▶▶** button to enter the sub-menus for TV-Y7, TV-PG, TV-14 or TV-MA.
- 5** If the TV-Y7, TV-PG, TV-14, or TV-MA sub-menu is accessed, press the **▶** or **■** button to select one of the options (Block All, V, S, L, D, or FV).
- 6** Press the **▶▶** button on the remote to turn the option ON or OFF.

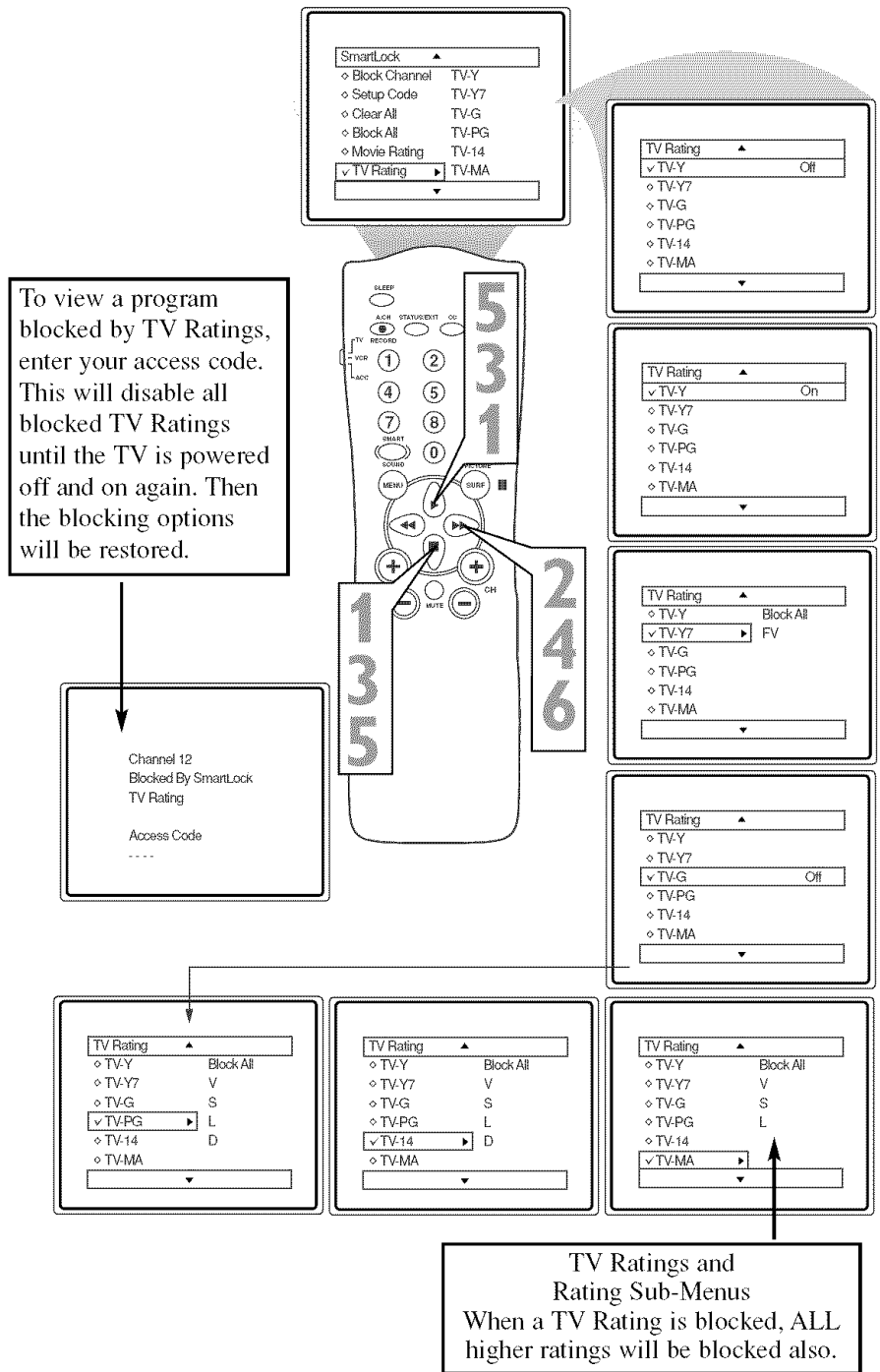

TV-Y - (All children -- *This program is designed to be appropriate for all children.*) Designed for a very young audience, including children ages 2-6. This type of programming is not expected to frighten younger children.

TV-Y7 - (Directed to Older Children -- *This program is designed for children age 7 and above.*) It may be more appropriate for children who have acquired the development skills needed to distinguish between make-believe and reality. This programming may include mild fantasy and comic violence (FV).

TV-G - (General Audience -- *Most parents would find this program suitable for all ages.*) This type of programming contains little or no violence, no strong language and little or no sexual dialog or situations.

TV-PG - (Parental Guidance Suggested -- *This program contains material that parents may find unsuitable for younger children.*) This type of programming contains one or more of the following: some suggestive dialog (D), infrequent coarse language (L), some sexual situations (S), or moderate violence (V).

TV-14 - (Parents Strongly Cautioned -- *This program contains some material that many parents would find unsuitable for children under 14 years of age.*) This type of programming contains one or more of the following: intensely suggestive dialog (D), strong coarse language (L), intense sexual situations (S), or intense violence (V).

TV-MA - (Mature Audience Only -- *This program is specifically designed to be viewed by adults and therefore may be unsuitable for children under 17.*) This type of programming contains one or more of the following: crude indecent language (L), explicit sexual situations (S), or graphic violence (V).

USING THE SMARTLOCK BLOCKING OPTIONS



SmartLock offers the viewer other blocking features. With these Blocking Options, the censoring can be turned ON or OFF.

- 1 Press the **MENU** button on the remote to show the on-screen menu.
- 2 Press the **▶** or **■** button until the word **FEATURES** is highlighted.
- 3 Press the **▶▶** button to display the **FEATURES** menu options.
- 4 Press the **▶** or **■** button until **SmartLock** is highlighted.
- 5 Press the **▶▶** button.
- 6 Enter the correct access code. "XXXX" shows on the Access Code display as you press the **Number buttons**. SmartLock menu options will be displayed.
- 7 Press the **▶** or **■** button until the words **BLOCKING OPTIONS** are highlighted.
- 8 Press the **▶▶** button to display the **Blocking Options (BLOCKING, UNRATED, or NO RATING)** menu.
- 9 Press the **▶** or **■** button to highlight the desired feature.
- 10 When highlighted, each feature can be turned **ON** or **OFF** using the **▶▶** or **◀◀** button on the remote.

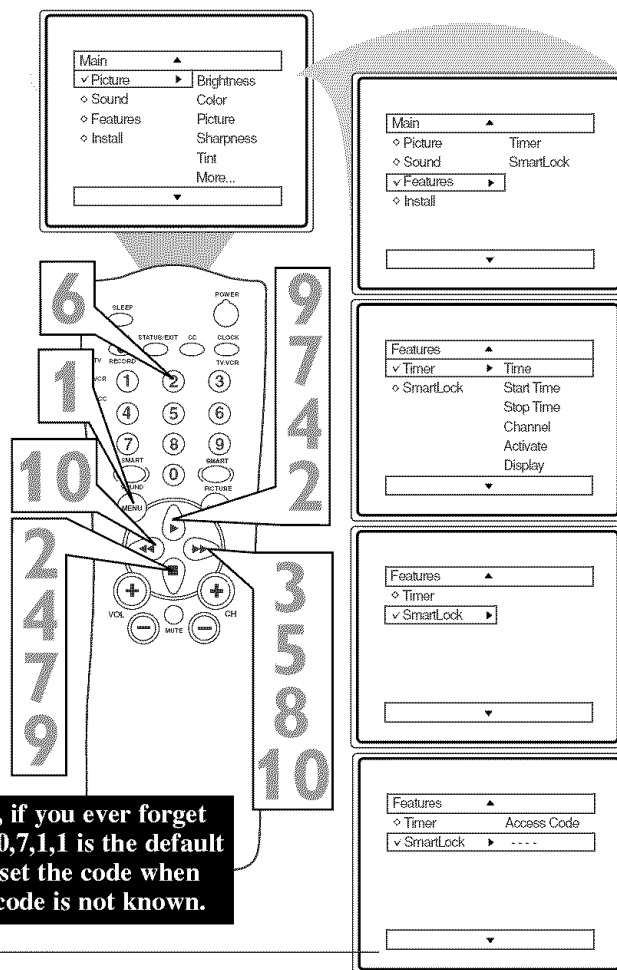

NOTE: Remember, if you ever forget your Access Code, 0,7,1,1 is the default code or a way to reset the code when the current access code is not known.

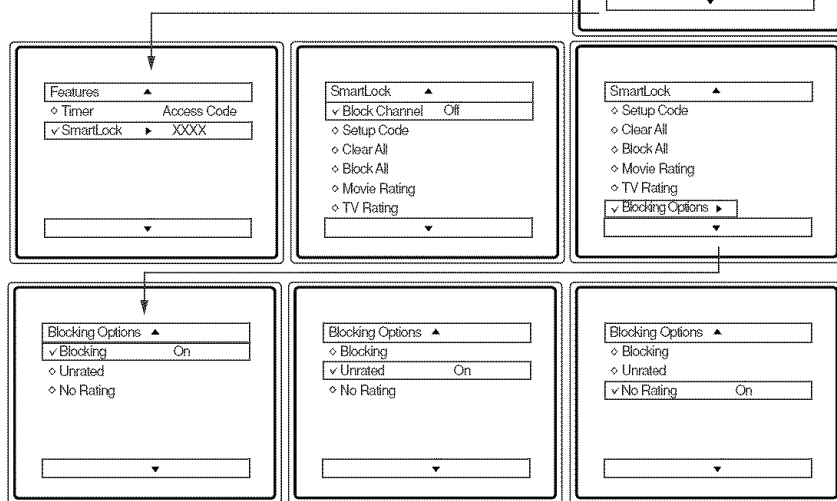

BLOCKING OPTIONS:

BLOCKING: This is what might be called the “master switch” for SmartLock. When ON, ALL blocking/censoring will take place. When OFF, ALL blocking is disabled.

UNRATED: ALL unrated programs based on the Movie Ratings or Parental (TV) Guidelines can be blocked if this feature is ON and **BLOCKING** is OFF.

NO RATING: ALL programming with NO content advisory data can be blocked if this feature is ON and **BLOCKING** is OFF.



HOW TO USE THE CLOSED CAPTION CONTROL

Closed Captioning (CC) allows you to read the voice content of television programs on the TV screen. Designed to help the hearing impaired, this feature uses on-screen "text boxes" to show dialog and conversations while the TV program is in progress.

- 1** Press the **CC** button on the remote to display the current Closed Caption setting.
- 2** Press the **CC** button repeatedly to choose from the four Closed Caption options (CC Off, CC 1, CC 2, or CC Mute). Dialog (and descriptions) for the action on the captioned TV program will appear on the screen if the tuned program is broadcasting CC information.
- 3** When finished, press **STATUS/EXIT** to remove the menu.

HELPFUL HINT

Not all TV programs and commercials include Closed Captioning. Neither are all Closed Caption modes (CC 1, CC 2) necessarily being used during the transmission of a closed caption program. Refer to your area's TV program listings for the stations and times of Closed Caption shows.

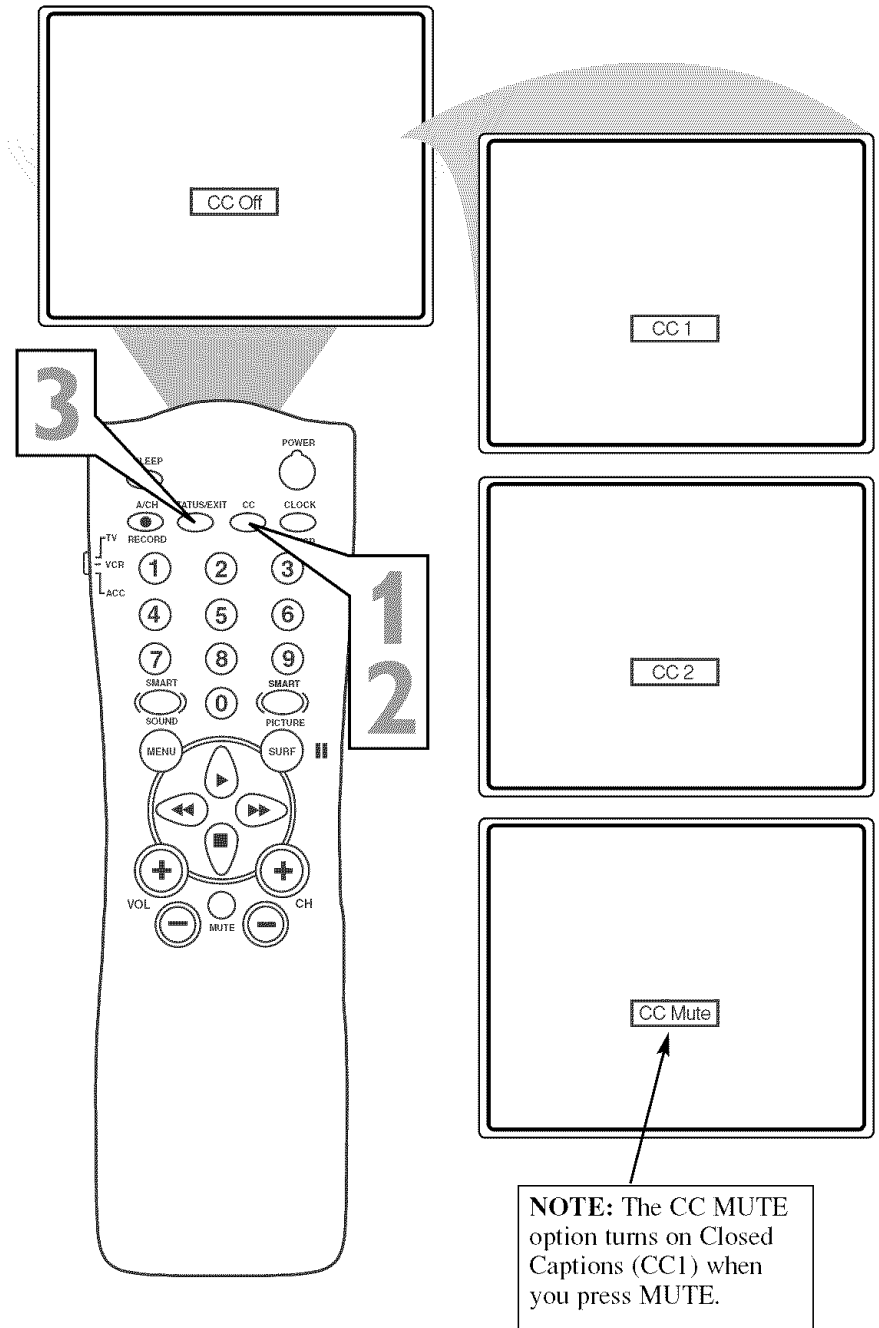

USING THE AUDIO/VIDEO INPUT JACKS



The TV's Audio/Video Input jacks are for direct picture and sound connections between the TV and a VCR (or similar accessory device) that has Audio/Video Output jacks.

- 1** Connect one end of the VIDEO (yellow) cable to the AV1 in VIDEO jack on the back of the TV. Then connect one end of the AUDIO (red and white) cables to the AV1 in AUDIO L and R (left and right) jacks on the rear of the TV.
- 2** Connect the other end of the VIDEO (yellow) cable to the VIDEO OUT jack on the back of the VCR. Then connect the other ends of the AUDIO (red and white) cables to the AUDIO (left and right) OUT jacks on the rear of the VCR.
- 3** Turn on the VCR and the TV.
- 4** Press the CH + or - button on the TV's remote to scroll the channels until AV1 appears in the upper left corner of the TV screen.
- 5** Slide the TV/VCR/ACC switch to the VCR position. Make sure you have set the TV's remote to operate your VCR. Details are on pages 30-35.
- 6** Now you are ready to place a videotape in the VCR and press the ► button. (Either press PLAY on the VCR or ► on the TV's remote if it is set to work the VCR.)

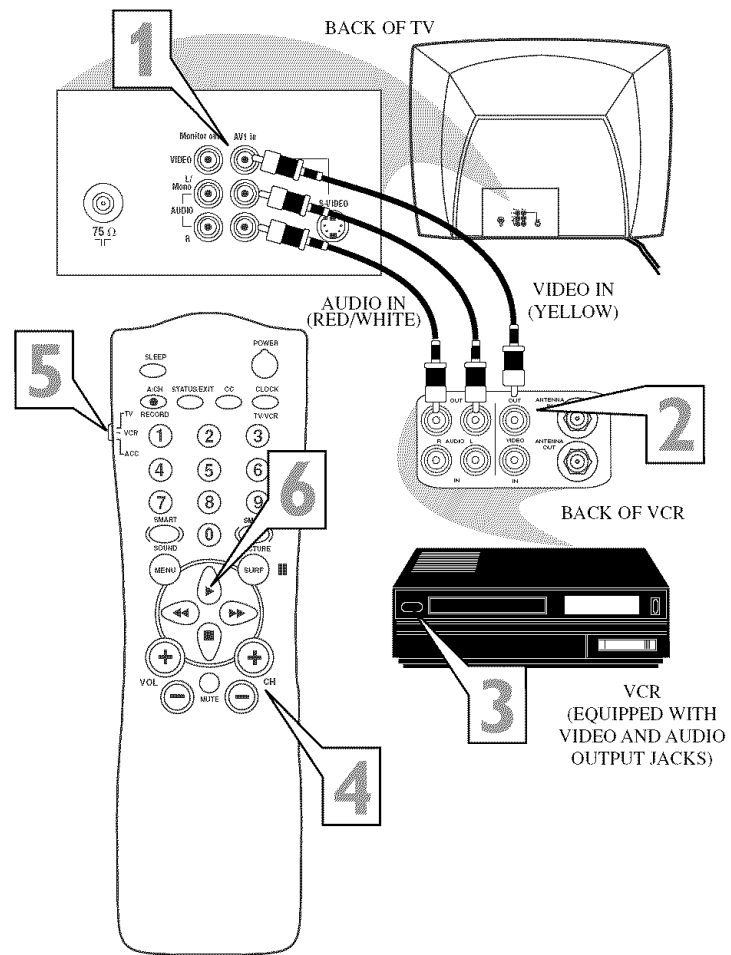

USING THE SIDE AUDIO/VIDEO INPUT JACKS

Audio and Video Side Inputs are available for a quick connection of a VCR, to playback video from a camera or attach a gaming device. Use the AV button on the remote control to tune these inputs.

- 1** Connect the video (yellow) cable from the Video output on the Camera (or accessory device) to the Video (yellow) Input located on the SIDE of the TV.
- 2** Connect the audio cable (red and white) from the Audio Left and Right Outputs on the Camera to a Stereo to Mono adapter. Then plug the single end of the adapter to the Audio In (white) jack on the SIDE of the television.
- 3** Turn the TV and the accessory device ON.
- 4** Press the CH + or - buttons to scroll the channels until Front appears in the upper left corner of the screen. Start the playback or use of the accessory device.

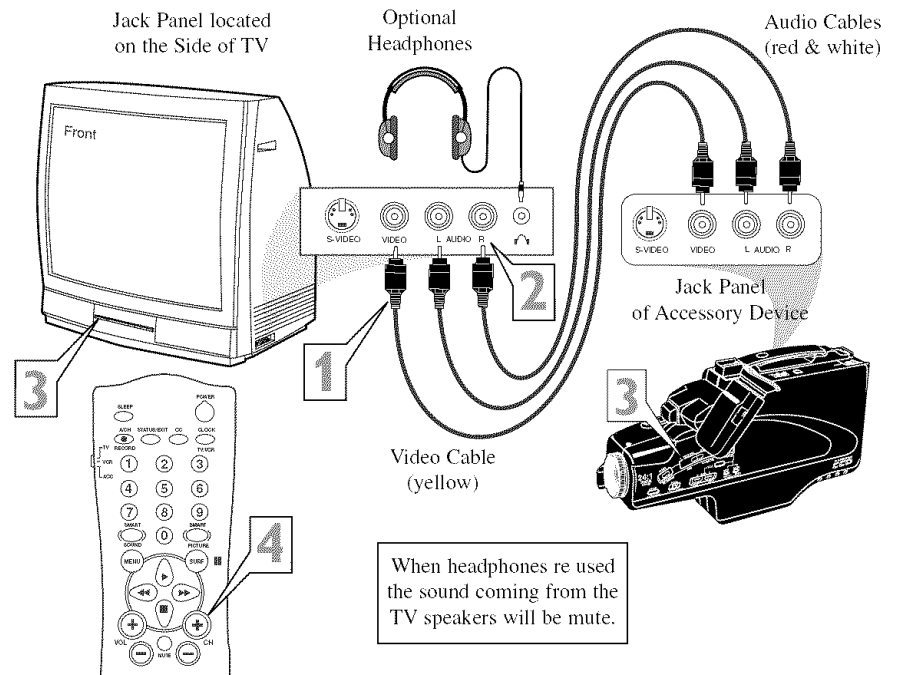



USING THE AUDIO/VIDEO (MONITOR) OUTPUT JACKS

The Audio/Video (Monitor) Output jacks are great for recording with a VCR or for use with an external audio system.

1 For an external audio system, connect audio cables to the R(ight) and L(eft) AUDIO (Monitor Out) jacks on the TV and to the Right and Left audio input jacks on your amplifier or sound system. Set the audio system's volume to a normal listening level.

2 Turn on the TV and the audio system. You can hear TV sound at the audio system. Adjust the volume at the audio system to a comfortable listening level.

To connect a second VCR for recording:

3 Connect one end of the yellow Video cable to the TV's Monitor Out VIDEO jack. Connect the other end of the cable to the VIDEO IN jack on the second VCR.

4 Connect the red and white Audio cables to the TV's Monitor Out AUDIO L and R jacks and to the AUDIO IN jacks on the VCR.

5 Turn on the VCR. Insert a blank VHS tape and it's ready to record what's being viewed on the TV screen.

For Stereo System:

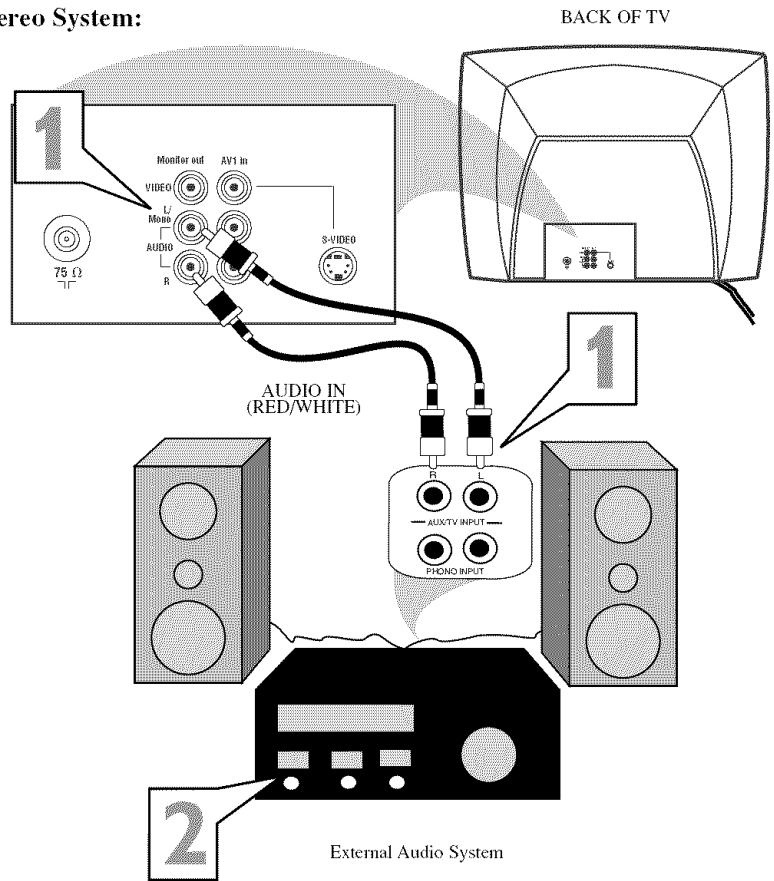

For Second VCR:

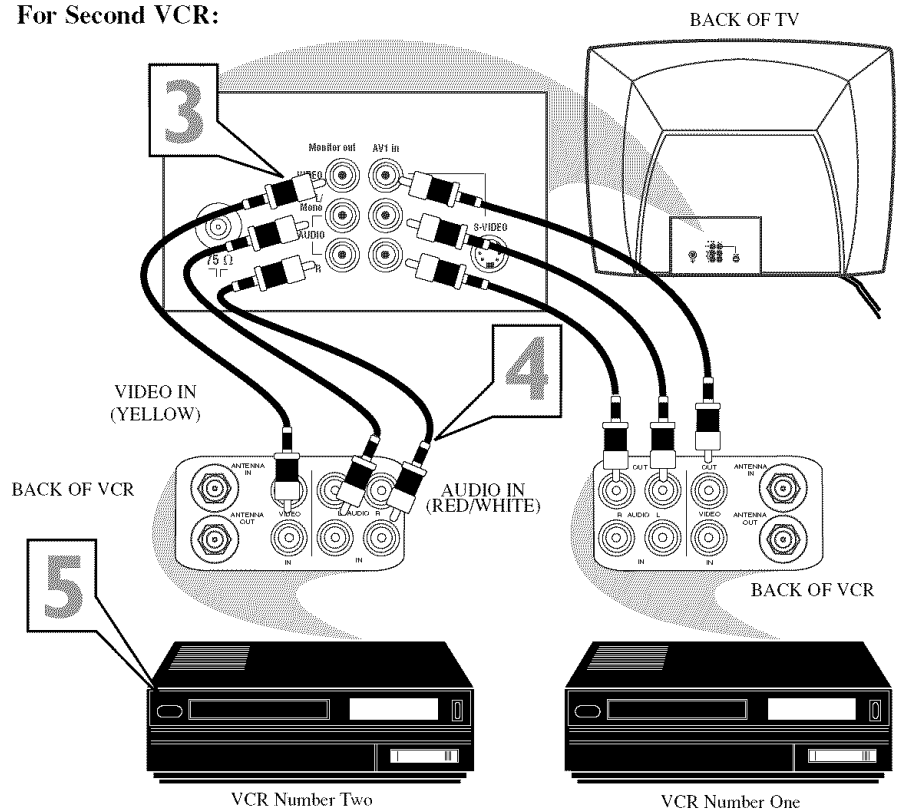

USING THE S-VIDEO INPUT JACK



The S(uper)-Video connection on the rear of the TV provides better picture detail and clarity from accessory sources such as a DBS (digital broadcast satellite), DVD Player (digital video discs), video games, and S-VHS VCR (video cassette recorder).

NOTE: The accessory device must have an S-VIDEO OUT jack in order for you to complete the connection on this page.

- 1** Connect one end of an S-VIDEO cable to the S-VIDEO jack on the back of the TV.
Connect one end of the AUDIO (red and white) cables to the AV1 In AUDIO L and R (left and right) jacks on the rear of the TV.
- 2** Connect the other end of the S-VIDEO cable to the S-VHS (S-Video) OUT jack on the VCR.
Connect the other ends of the AUDIO (red and white) cables to the AUDIO (left and right) OUT jacks on the rear of the VCR.
- 3** Turn on the VCR and the TV.
- 4** Press the CH + or - buttons on the TV's remote to scroll the channels until SVHS appears in the upper left corner of the TV screen.
- 5** Slide the TV/VCR/ACC switch to the VCR position. Make sure you have set the TV's remote to operate your VCR. Details are on pages 30-35.
- 6** Now you are ready to place a videotape in the VCR and press the ► button. (Either press PLAY on the VCR or ► on the TV's remote if it is set to work the VCR.)

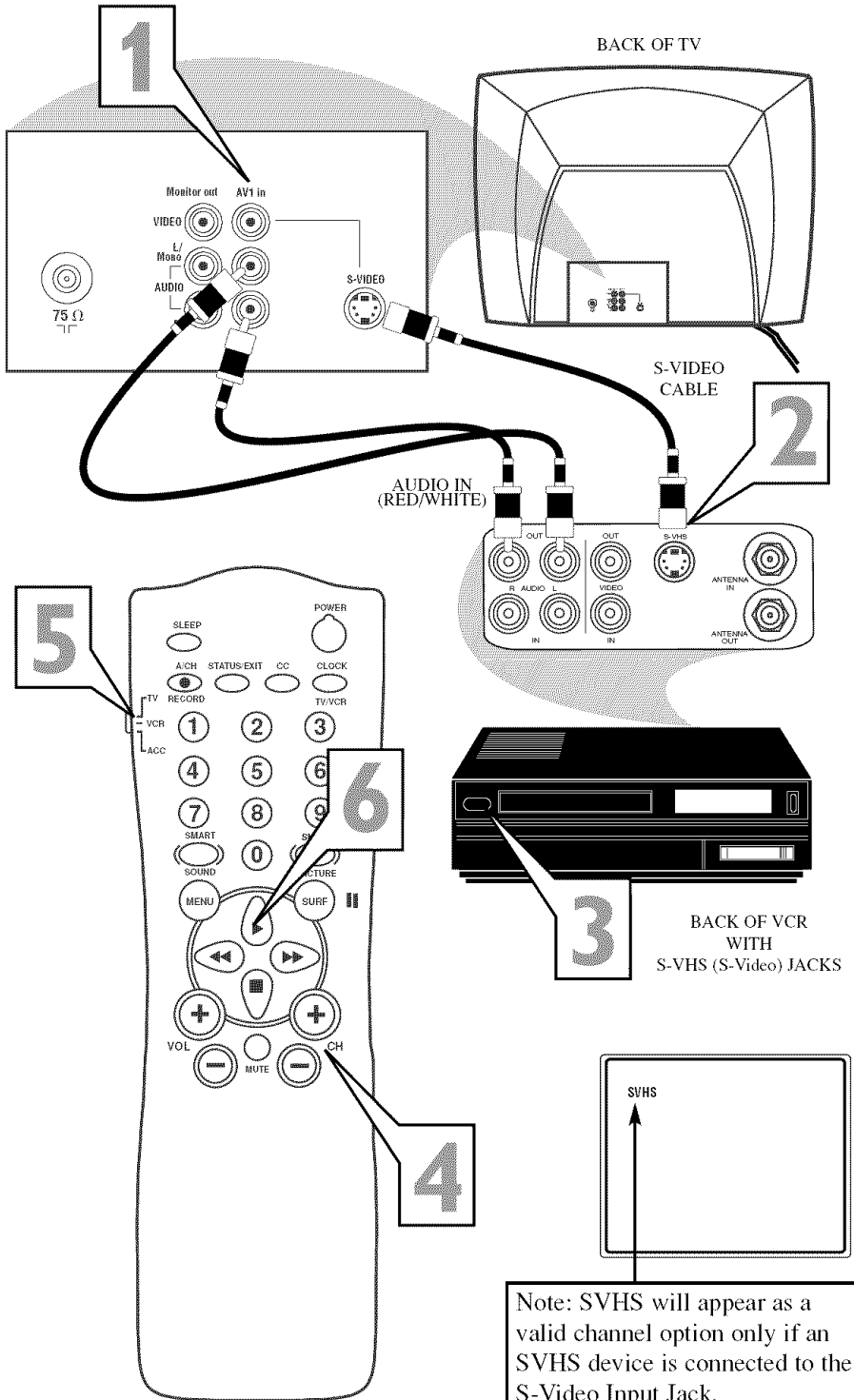

HELPFUL HINT

The S-VIDEO and VIDEO AV1 inputs work in parallel. The S-VIDEO input is dominant when in use. If separate video signals are connected to the S-VIDEO and VIDEO AV1 inputs, the signal at the VIDEO AV1 input will not be usable.

Note: SVHS will appear as a valid channel option only if an SVHS device is connected to the S-Video Input Jack. If the device is connected to AV1 Video In, the channel will appear as AV1.



SETTING UP THE SLEEPTIMER OPTION

Have you ever fallen asleep in front of the TV only to have it wake you up at two in the morning with a test pattern screeching in your ears? Well, your TV can save you all that trouble by automatically turning itself off.

- 1 Press the SLEEP button** on the remote control and the SleepTimer display will appear on the screen.
- 2 Press the SLEEP button repeatedly** to pick the amount of time (15, 30, 45, 60, 90, 120, 180, or 240 minutes) before the TV will turn itself off.

An on-screen count down will appear during the last minute before the TV shuts itself off.

HELPFUL HINT

The on-screen menu will time out and disappear from the screen when you finish. Or, press STATUS/EXIT to clear the menu from the screen.

After a SleepTimer setting has been made, pressing STATUS/EXIT will display the remaining time before the TV will shut off.

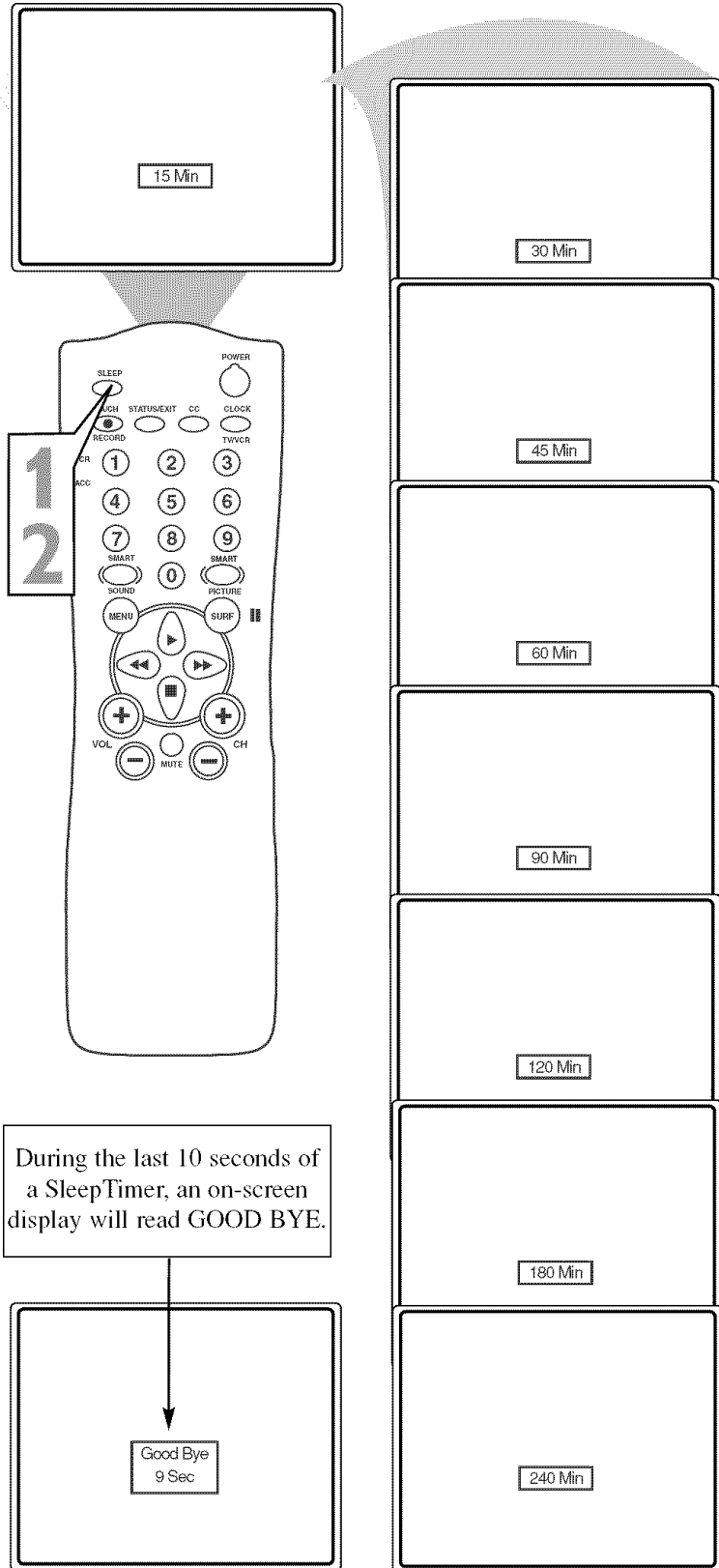

SETTING THE SMARTPICTURE CONTROL



Whether you're watching a movie or a sporting event, your TV has automatic video control settings matched for your current program. The SmartPicture feature quickly resets your TV's video controls for a number of different types of programs and viewing conditions. Each SmartPicture setting is preset at the factory to adjust the TV's Brightness, Color, Picture, Sharpness, Tint, Color Temperature, DNR (Dynamic Noise Reduction), and Contrast+ levels.

- 1** Press the **SMART PICTURE** button on the remote control. The current SmartPicture setting will appear in the middle of the screen.
- 2** Press the **SMART PICTURE** button repeatedly to select either **PERSONAL**, **MOVIES**, **SPORTS**, **WEAK SIGNAL**, or **MULTI MEDIA** picture settings.

Note: You set the **PERSONAL** setting using the **PICTURE** options in the on-screen menu. This is the only SmartPicture setting that can be changed. All other settings are set at the factory during production.

MOVIES - Preset picture options for watching Videotapes or DVDs.

SPORTS - Preset picture options for watching sporting events.

WEAK SIGNAL - Preset picture options for watching programs when the reception is poor.

MULTI MEDIA - Preset picture options for use with video games.

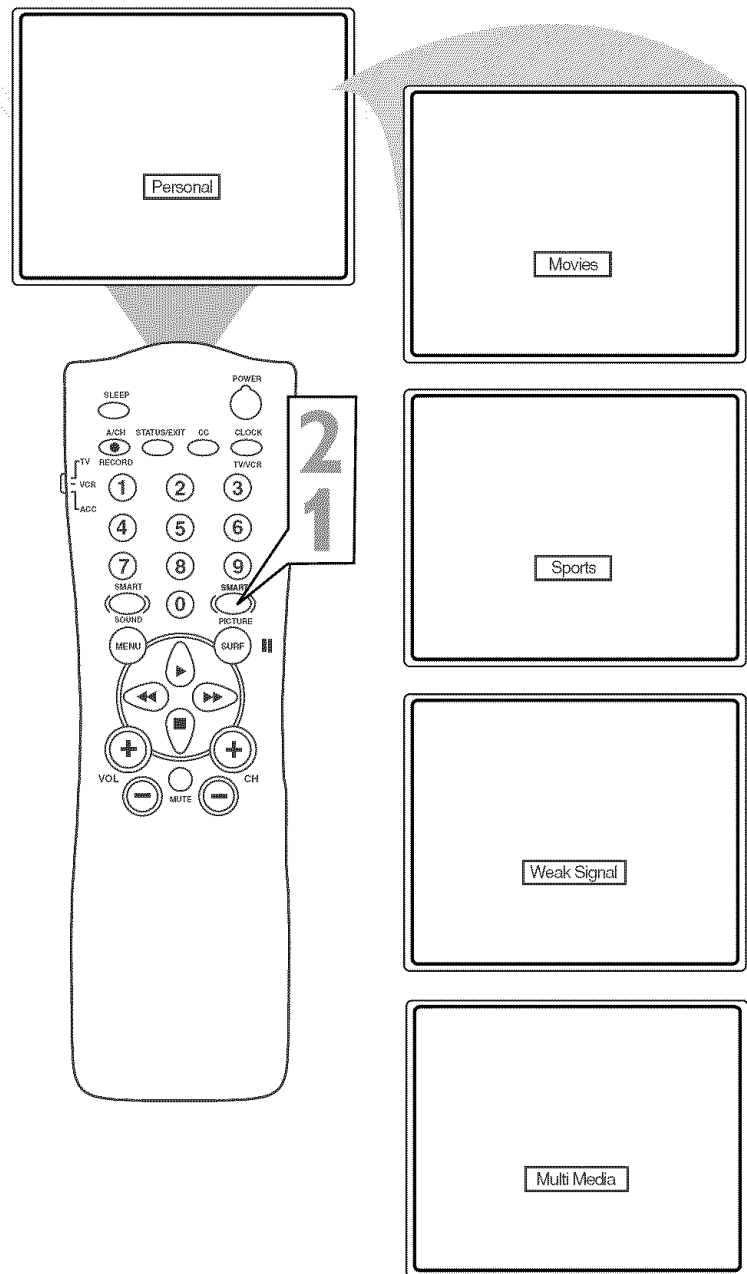



SETTING THE SMARTSOUND CONTROL

SmartSound allows you to select one of four factory-set sound options: Personal (which can be set by the user), Theatre (for movie viewing), Music (for musical programming), and Voice (when the program is mainly dialog). These settings affect the Sound menu's Bass, Treble, AVL (Automatic Volume Leveler), and Incredible Surround controls. To select any of the options, follow the directions below.

- 1** Press the **SMART SOUND** button on the remote control. The current SmartSound setting will appear in the middle of the screen.
- 2** Press the **SMART SOUND** button repeatedly to toggle between the four settings.

Note: Only the **PERSONAL** control can be changed by the viewer. This changes the settings in the menu's **SOUND** controls.

THEATRE - Preset sound options for watching movies.

MUSIC - Preset sound options for musical programming where there is little dialog.

VOICE - Preset sound options for programming where heavy dialog is present.

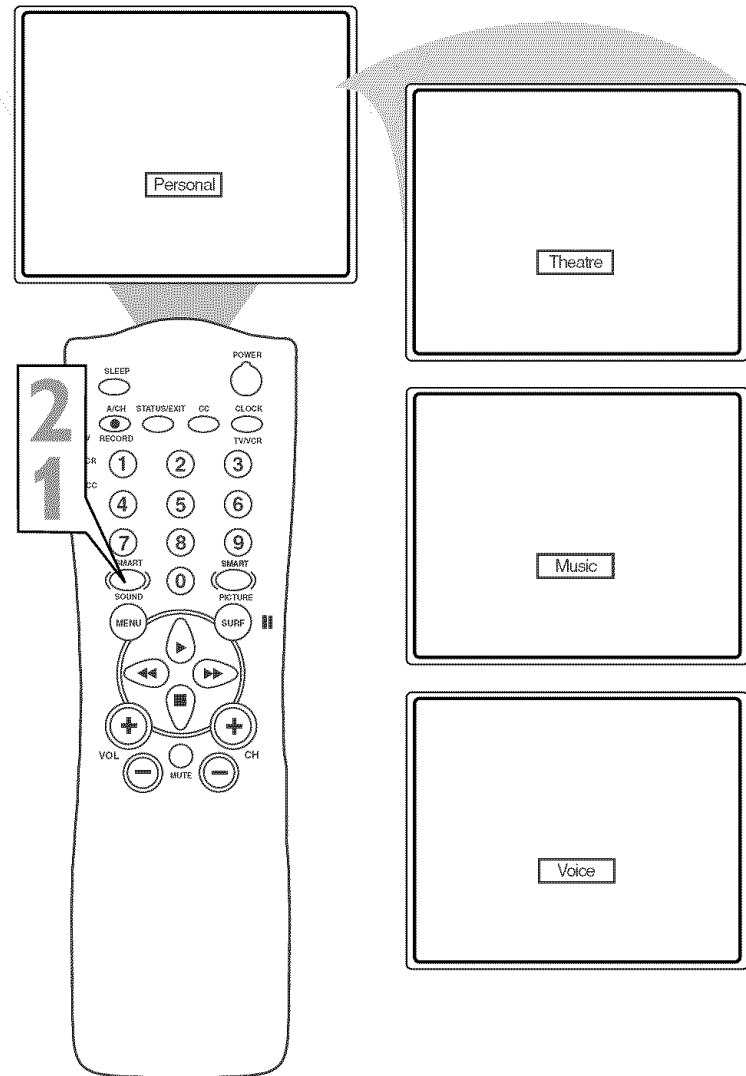

USING THE SURF BUTTON (AND THE ALTERNATE CHANNEL BUTTON)



A "list" or series of previously viewed channels can be selected using the SURF button on your remote control. With this feature you can easily switch between different TV programs that currently interest you. SmartSurf allows you set up to eight channels in its quick viewing "list."

- 1** Press the CHANNEL (+) or (-) button (or the Number buttons) to select a channel to add to the SURF list.
- 2** Press the SURF button on the remote. The channel number will be displayed with the word ADD to the right.
- 3** Press the ►► button to ADD the channel to the Surf list. The display will change from ADD to DELETE.

Repeat steps 1 through 3 to add additional channels (up to eight) to the SURF list. As soon as a ninth channel is added, the first channel in the list will be removed.

How to select Surf channels:

- 4** Press the SURF button on the remote control.
- 5** Press the ► or ◄ button to scroll the list of up to eight channels. As you scroll to a channel, the TV will tune to that channel.

To remove a channel from the SURF list:

Follow steps 4 and 5 to select a channel in the Surf list.

- 6** While the Surf Channel List is still displayed on the screen, press the ►► button to DELETE the channel from the list. The display will change from DELETE to ADD.

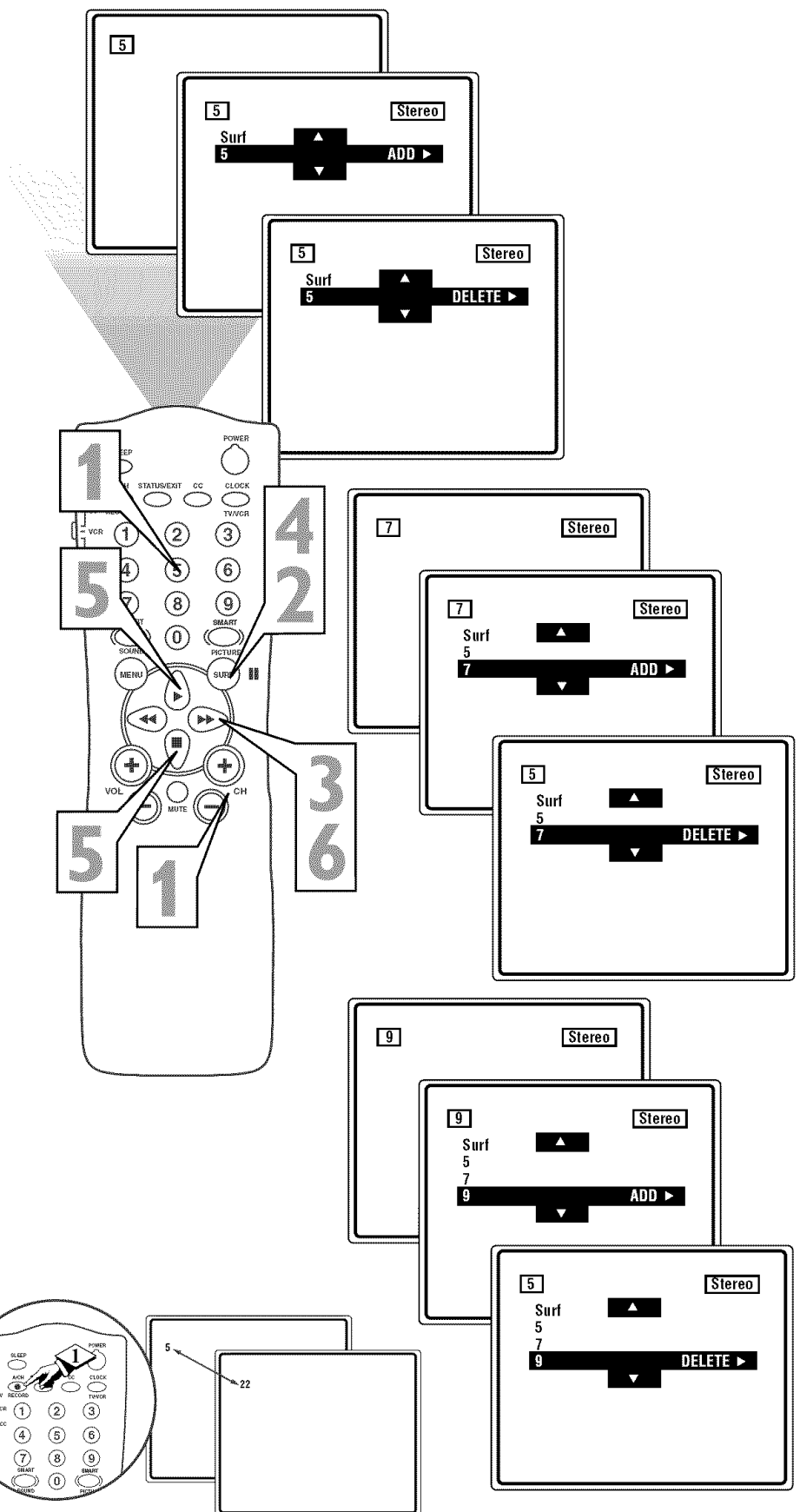

A/CH BUTTON

Your remote also has an A/CH (Alternate Channel) button. Pressing this button will toggle between the current and the previous channel.

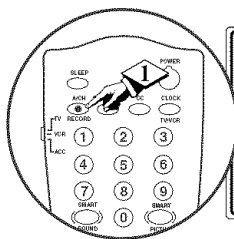



REMOTE USE WITH ACCESSORY DEVICES - DIRECT METHOD

Your remote control can work your TV and some VCRs, Cable Boxes, Satellite Systems, DBS, DVD Players, etc. However, an easy one-time step may be necessary before the remote will work your other equipment.

Try this initial check to see if you need to go to the following section.

- 1** Place the TV/VCR/ACC Mode Switch in the proper position (VCR or ACC for other devices) for the device you want to control.
- 2** Point the remote control at the device and press the POWER button.
- 3** Does the remote turn the device ON?
 If YES, stop and try other function buttons on the remote. If they also work the device, then the remote is ready and no further steps are needed.
 If NO, continue...

First look up a **THREE-DIGIT remote control number** for your brand of device before going through the simple steps on the following page.

Find your three-digit code on pages 33-34.

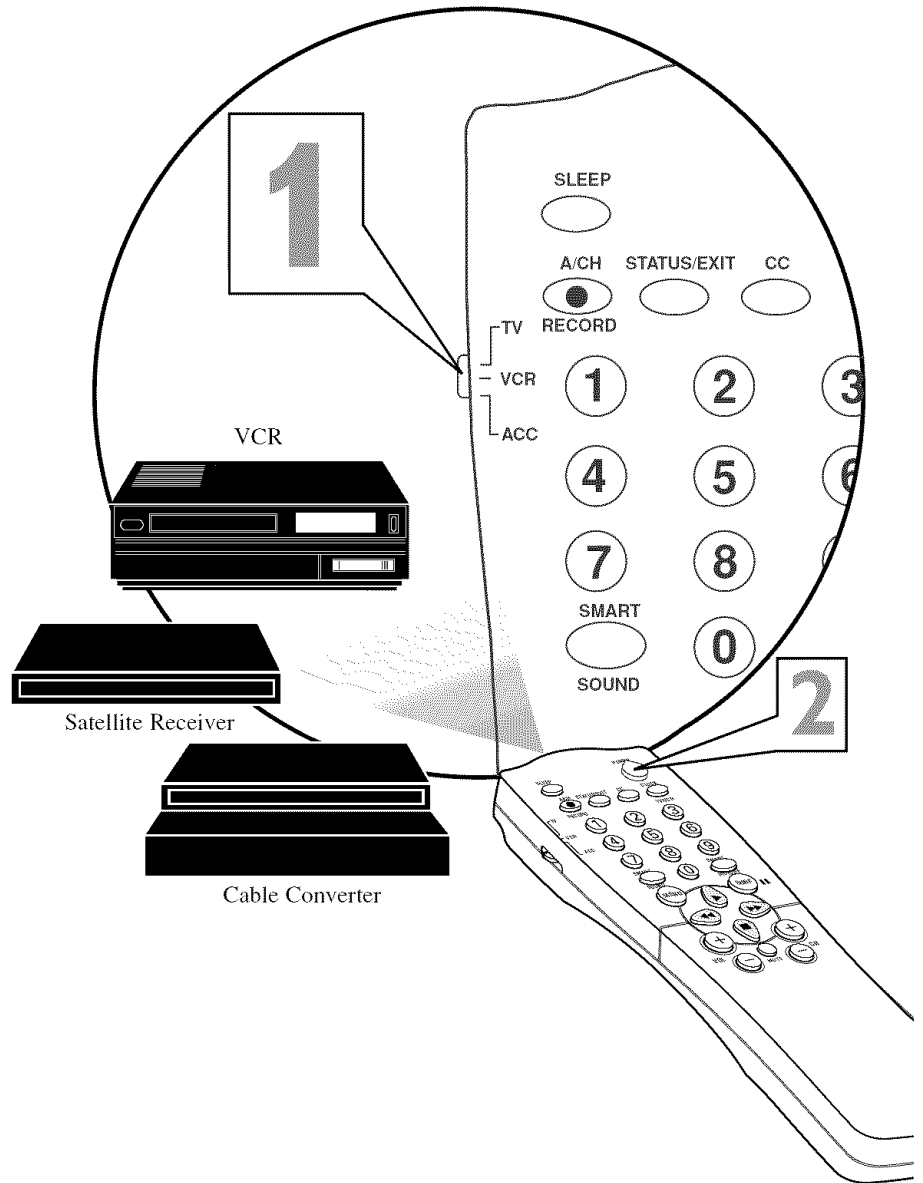

HELPFUL HINT

Remember, if more than one code is listed for your brand of device, you may have to try more than the first three-digit code given in order to locate your device's remote code.

NOTE: The remote is for use with external accessory devices only and not for use with other brands of TVs.



CODE ENTRY METHOD

Now that you have looked up the three-digit code for your brand of device, you are ready to follow the four simple steps below.

Please read through steps 1-5 before beginning.

- 1** Place the **TV/VCR/ACC Mode Switch** in the proper position for the device you want to control.
- 2** Press the **A/CH • RECORD** button on the remote control and release.
- 3** Press the **SMART SOUND** button on the remote within 30 seconds, then release.
- 4** Press the **Number buttons** to enter the **THREE-DIGIT CODE** for your desired device. The remote is now ready to operate the device.
- 5** Point the remote at the device. Press the **POWER** button on the remote to turn the unit ON.

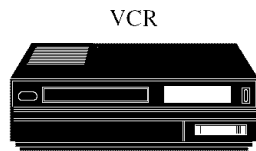
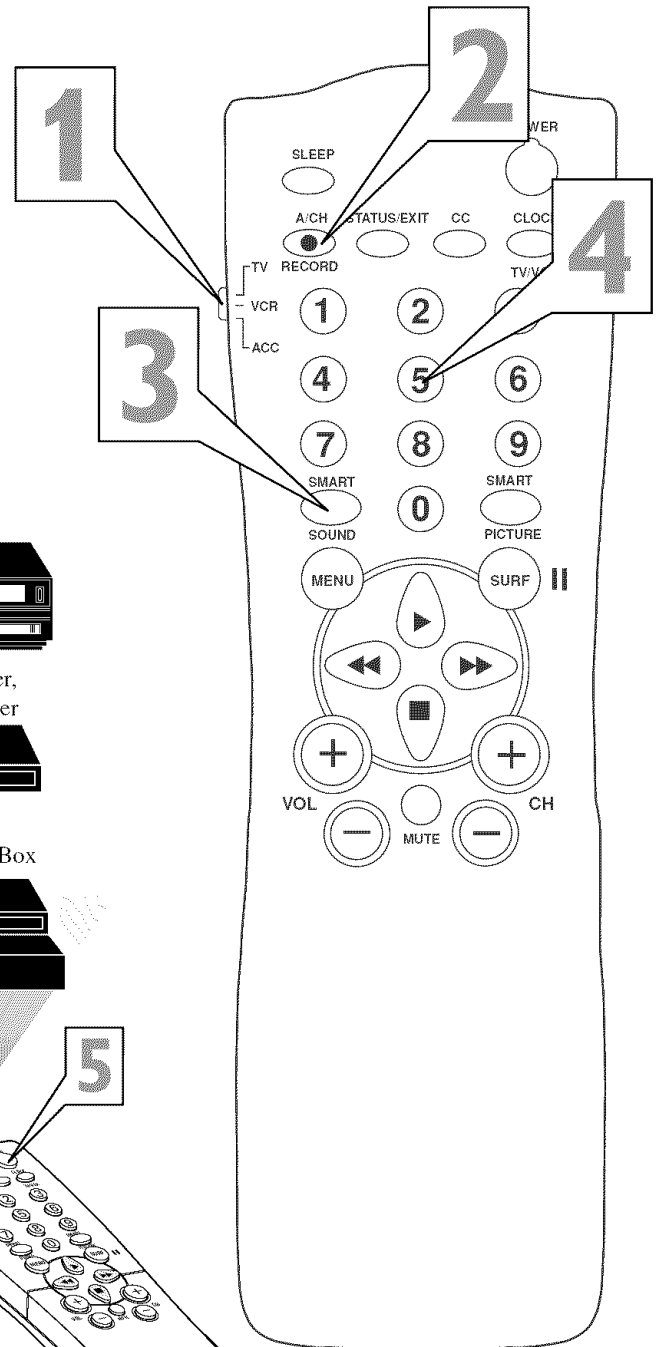

VCR

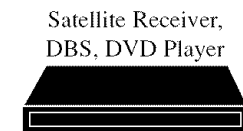

Satellite Receiver,
DBS, DVD Player

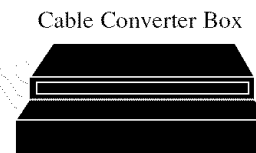

Cable Converter Box

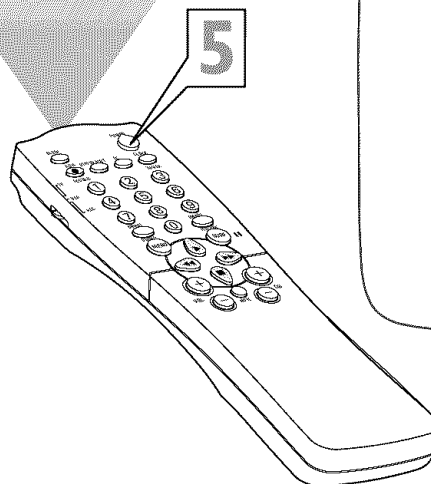

HELPFUL HINT

Remember, if this doesn't work the first time, repeat these steps using the same remote code.

If the remote does not operate your device after a second try, see if there is another three-digit code (pages 33-34) for your device. Repeat the steps using the new number.

If the code method does not work your device after repeated attempts, try the **SEARCH METHOD** on the next page.

NOTE: The remote is for use with external accessory devices only and not for use with other brands of TVs.



REMOTE USE WITH ACCESSORY DEVICES - SEARCH METHOD

SEARCH METHOD

Your TV remote can be set to work various external devices such as VCRs, Cable Boxes, Satellite Receivers, DBS, DVD Players, etc., by using the search method of remote control programming.

If the Code Entry method shown on the previous page did not set your remote to work your external device, then follow the easy steps listed below.

Please read steps 1-4 before beginning.

- 1** Press the **POWER** button on the accessory device to turn it ON.
- 2** Place the **TV/VCR/ACC Mode Switch** in the proper position for the device you want to operate.
- 3** Press and hold the **A/CH • RECORD** and **SMART SOUND** buttons simultaneously.
- 4** The device will begin to change channels after the remote identifies the correct code. **When the channels start to change, release the A/CH • RECORD and SMART SOUND buttons.** The remote should be ready to operate the device.

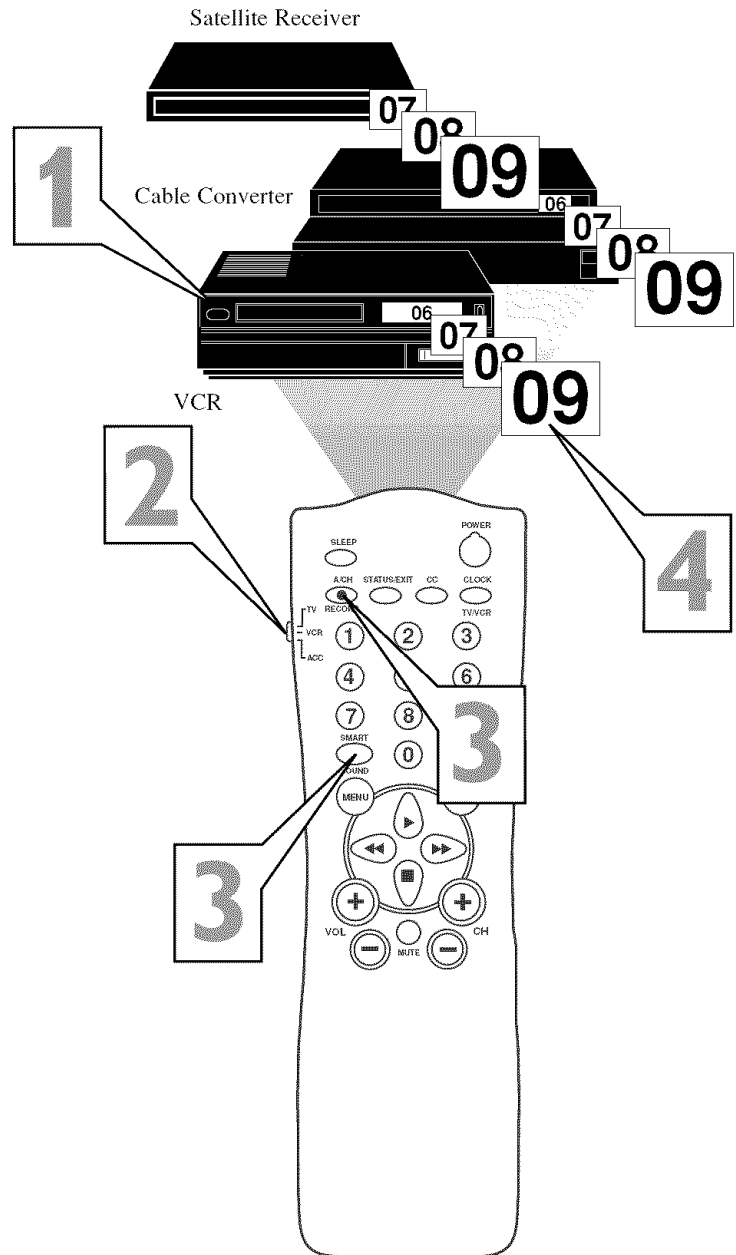

HELPFUL HINT

This method can take up to two minutes to perform.

Don't let the device scan up more than five channels. If you do, the remote may pass up the right code and another two minute search cycle will have to be repeated.

If no channel change happens within two minutes, repeat steps 1-4. Should a channel change still not occur, the remote will not work the desired device.

NOTE: The remote is for use with external accessory devices only and not for use with other brands of TVs.

REMOTE CONTROL CODES



<u>VCR</u>	<u>CODE NO.</u>
Admiral	.048
Advantz	.358
Adventure	.000
Aiko	.278
Aiwa	.000, 037, 307, 348, 352
Akai	.041, 049, 053, 061, 106, 315
Alba	.352
American High	.035
Amstrad	.325, 332
Asha	.240
Audiovox	.037
Baird	.107
Beaumont	.240
Bell & Howell	.104
Blaupunkt	.003, 006, 154
Brandt	.187, 320, 321
Broksonic	.121, 184, 211, 295, 361
Bush	.352
CCE	.072, 278
Calix	.037
Canon	.035
Capehart	.020
Carver	.081, 146
Citizen	.037, 278
Colt	.072
Combitach	.352
Craig	.037, 047, 072, 240, 271
Curtis Mathes	.035, 041, 060
Cybermax	.051, 240
Daewoo	.020, 045, 276
Daytron	.020
Denon	.042
Dynatech	.000
Electroponic	.037
Emerex	.032
Emerson	.000, 002, 036, 037, 043, 061 .068, 088, 121, 164, 208, 209, .211, 212, 278, 295, 361, 479
Ferguson	.107, 320, 321
Fisher	.047, 054, 066, 104
Fuji	.033, 035
Funai	.000
GE	.035, 060, 065, 202
Garrard	.000
Go Video	.232, 279, 432
Gold Star	.037, 038
Gradiente	.000, 406
Grundig	.003, 007, 195, 347
HI-Q	.047
Harley Davidson	.000
Harman/Kardon	.038, 075
Harwood	.068, 072
Headquarter	.046
Hinari	.004, 352
Hitachi	.000, 004, 041, 042, .065, 105, 168, 235
Ingersol	.004
JVC	.008, 041, 067, 208, 384, 486
Jensen	.041
KEC	.037, 278
KLH	.072
Kenwood	.038, 041, 067, 384
Kodak	.035, 037
LXI	.037
Lloyd's	.000, 206

<u>VCR</u>	<u>CODE NO.</u>
Loewe	.004
Logik	.004, 072
MEI	.035
MGA	.043, 061
MGN Technology	.240
MTC	.000, 240
Magnavox	.000, 035, 081, 146, 181
Marta	.037
Matsui	.004, 348, 352
Matsushita	.035, 162, 454
Memorex	.000, 035, 037, 039, 046, .047, 048, 104, 240, 266, 307 .003, 347
Metz	.042, 105
Minolta	.043, 061, 067, 075, 173, 443
Mitsubishi	.035, 048
Motorola	.000, 072
Multitech	.058
NAD	.036, 040, 041, 067, 104
NEC	.037
Nikko	.034, 253
Nikon	.240
Noblex	.297, 320, 321
Nordmende	.346
Okano	.035, 226
Olympus	.037, 048, 058, 104, .162, 432, 454 .062
Optimus	.004, 295, 348, 352, 479
Orion	.035, 077, 162, 225, .226, 378, 454
Panasonic	.035, 037, 038, 040, .042, 065, 105
Penney	.042, 065, 105 .035
Pentax	.035, 062, 081, 110, 403
Philco	.037
Philips	.058, 067
Pilot	.020
Pioneer	.322
Portland	.240
Profax	.072
Profronic	.039, 051
Protec	.046
Pulsar	.046
Quarter	.046
Quartz	.035, 077, 162, 454
Quasar	.042, 060, 065, 077, .105, 106, 149, 202
RCA	.000, 037
Radio Shack	.037
Radix	.037
Randex	.037
Realistic	.000, 035, 037, 045, 047 .048, 062, 066, 104
Ricoh	.034, 253
Runco	.039
SEG	.322
SEI	.004
STS	.042
Saba	.297, 320, 321
Saisho	.004
Salora	.075
Samara	.045, 051, 053, 240
Samsung	.039, 048
Sanky	.000, 041, 067, 271
Sansui	.046, 047, 104, 240, 268
Sanyo	

<u>VCR</u>	<u>CODE NO.</u>
Saville	.352
Scott	.043, 045, 121, 164, 211, 212
Sears	.000, 035, 037, 042, 046, .047, 054, 066, 104, 105
Sharp	.046, 062
Shintom	.072
Shogun	.051, 240
Shoral	.004
Siemens	.003
Singer	.072
Sinudyne	.004
Sony	.000, 011, 022, 032, 033, .034, 035, 253, 275 .348
Sunkel	.253
Sunpak	.000, 035, 043, 081, 103, 110
Sylvania	.000
Symphonic	.036, 208, 240
TMK	.322
Tansal	.041
Tatung	.000, 041
Teac	.035, 162
Technics	.000, 035, 037
Teknika	.187, 320, 321
Telefunken	.000
Thomas	.320
Thomson	.043, 045, 066, 212, 366
Toshiba	.037, 240
Totevision	.322
Towada	.240
Unitech	.325
Universum	.045
Victor	.038, 040
Victor Research	.040, 045, 061
Video Concepts	.240
Videosonic	.000, 035, 042, 047, 048, 060, 062, .072, 081, 149, 161, 212, 240
Wards	.000, 035, 072
XR-1000	.038
Yamaha	.000, 033, 034, 039
Zenith	

CABLE

<u>CONVERTER</u>	<u>CODE NO.</u>
ABC	.001, 003, 007, 008, .011, 013, 014, 017 .153
Aliegio	.544
Andover	.022
Antronix	.153
Archer	.022, 153
Balcor	.056
British Telecom	.105
Cable Star	.056
Cabletenna	.022
Cabletime	.161, 271, 377, 448
Cableview	.022
Century	.153
Citizen	.153
Clyde	.086
Colour Voice	.025, 031
Comtec	.274
Comtronics	.040
Contec	.019
Cryptovision	.600
Deceat	.423



REMOTE CONTROL DIRECT ENTRY CODES

CABLE CONVERTER	CODE NO.
Eastern	.002, 274
Everquest	.015, 040
Filmnet	.443
Focus	.400
France Telecom	.451
GC Electronics	.056
GEC	.086
Ganard	.153
Gemini	.015, 070, 242
General Instrument	.011, 276, 476
Gold Star	.040
Grundig	.529
Hamlin	.009, 020, 034, 259
Hitachi	.011
Hytex	.007
Jasco	.153
Jerrold	.003, 011, 012, 014, .015, 024, 276, 476
M.N.E. T.	.443
MNet	.443
Macon	.033
Magnavox	.027, 032, 334
Memorex	.000
Movie Time	.063
NSC	.063, 070
Oak	.007, 019
Optimus	.021
Panasonic	.000, 021, 107
Paragon	.000
Philips	.025, 027, 031, 153, 242, 290, 334
Pioneer	.533, 753
Popular Mechanics	.400
Pulsar	.000
RCA	.021
Radio Shack	.015
Recoton	.400
Regal	.020, 259
Regency	.002
Rembrandt	.011, 070
Runco	.000
SL Marx	.040
Salora	.382
Samsung	.040
Satbox	.375
Scientific Atlanta	.008, 017, 477
Signal	.015, 040
Signature	.011
Sprucer	.021
Star Sight	.542
Starcom	.003, 015
Stargate	.015, 040
Starquest	.015
Sylvania	.001
TV85	.063
Tandy	.258
Tele+1	.443
Teleservice	.281
Televue	.040
Texscan	.001
Timeless	.274
Tocom	.012, 013, 059
Toshiba	.000
Tudl	.286
Tusa	.015
Unike	.022, 153

CABLE CONVERTER	CODE NO.
United Artists	.007
United Cable	.003
Universal	.022, 056, 153, 191
Videoway	.250
Viewstar	.027, 063, 258
Visi Cable+	.461
Westminster	.105
Wolsey Gaine	.544
Zenith	.000, 054, 525
Zentek	.400

DBS	CODE NO.
Alpha Star	.772
Echostar	.775
HTS	.775
Hitachi	.819
Hughes Network System	.749
Jerrold	.627
Magnavox	.722, 724
Memorex	.724
Panasonic	.701
Philips	.722, 724
Primestar	.627
RCA	.566
Sony	.639
Toshiba	.790
Uniden	.724

SATELLITE	CODE NO.
AST	.351
Akai	.515
Alba	.352, 515, 613
Aldea	.288
Amstrad	.080, 252, 345, 461, 509, 689
Ankaro	.220, 288, 369
Anitron	.183
Armstrong	.243
Astra	.108
Avalon	.396
Axis	.369
BT	.515, 668
Beko	.189
Best	.369
Boca	.243, 513
Bush	.067
Cambridge	.344, 515
Channel Master	.362
Commlink	.288
Connexions	.396
Conrad	.607
Crown	.243
DDC	.362
DNT	.396
Echostar	.396
Ferguson	.067, 183, 189, 336
Fidelity	.252
Finlux	.108, 397
Fuba	.369, 396
G-Bat	.183
Galaxis	.286
Gooding	.571
Grundig	.173, 189, 571, 750
Hinari	.183

SATELLITE	CODE NO.
Hirschmann	.397, 573
Houston	.668
Huth	.220, 243, 268
ITT	.108
Intervision	.592
JVC	.515, 571
Kathrein	.092, 504, 622, 658
La Sat	.513, 607
Lennox	.592
Lupus	.369
Luxor	.108, 573
Manhattan	.592
Maspro	.092, 336, 750
Matsui	.571
Mediamarket	.248
Minerva	.571
Mintec	.576
Morgan's	.243, 513
Newhaus	.220
Nikko	.360, 713
Nokia	.108, 397, 573
Nordmende	.362
Orbitech	.501
Pace	.067, 183, 336, 455, 791
Paliadium	.571
Palsat	.501
Philips	.200, 292, 571, 750
Phonotrend	.288, 592
Plasmatic	.442
Proset	.288
Quadral	.362, 628
RFT	.220, 288
Radix	.396
SAT	.351, 461
SEG	.369
Saba	.336
Salora	.108
Satec	.183
Schwaiger	.183, 504
Seemann	.396, 578, 626
Skymaster	.288, 626
Sony	.704
Star Trak	.421
Strong	.421
Sunstar	.513
Tantec	.336
Techni Sat	.262, 501
Teleka	.243, 613
Tonna	.668
Triad	.351
Universum	.571
Vtech	.351
Wisi	.351, 396

DVD	CODE NO.
Kenwood	.534
Mitsubishi	.521
Panasonic	.490
Philips	.539
Pioneer	.550
RCA	.522
Sony	.552
Toshiba	.503

USING THE REMOTE'S VCR BUTTONS



When using the TV remote with a VCR, first make certain it is set to control your VCR.

- 1** Set the TV/VCR/ACC mode switch to VCR on the remote.
- 2** Point the top of the remote toward the front of the VCR (remote sensor window) when pressing the buttons.

A/CH • RECORD BUTTON

Press and hold to begin a VCR recording.

TV/VCR/ACC SWITCH

Set to VCR to send commands to the VCR.

PLAY BUTTON ▶

Press to play a videotape.

REWIND BUTTON ◀◀

Press to rewind tapes. For some VCRs, you may have to stop the tape first. During playback, hold down the button to view the picture moving rapidly in reverse.

STOP BUTTON ■

Press to stop a tape.

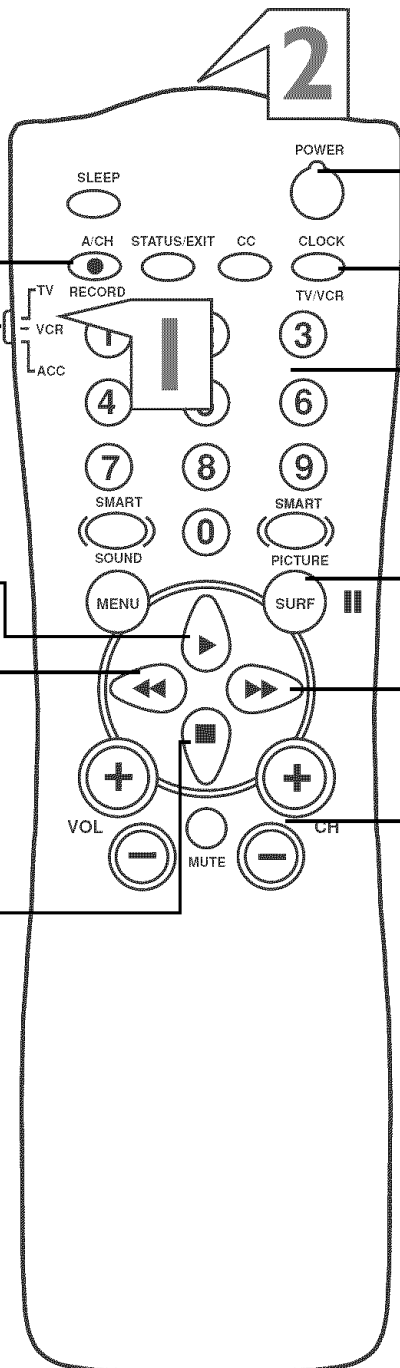

POWER BUTTON

Press to turn the VCR ON and OFF.

CLOCK • TV/VCR BUTTON

Press to choose VCR or TV position at the VCR. In VCR position, you can view tapes. Use TV position to view one program while recording another.

In TV position, the TV/VCR/CLOCK button may access the TV's Clock menu.

NUMBER BUTTONS

Press to select channels at the VCR.

SURE/II (PAUSE) BUTTON

Press to temporarily stop the tape during play or recording. Press again to release Pause.

FAST FORWARD BUTTON ▶▶

Press to rapidly advance the tape. For some VCRs you may need to stop the tape first. During playback, press and hold the button to view the picture moving forward rapidly.

CHANNEL +/- BUTTONS

Press to scan up or down through the VCR channels.

HELPFUL HINTS

The VCR buttons on the remote will not operate your VCR if those features are not on your original VCR remote control.

All VCR functions (particularly Search, Rewind, Fast Forward, etc.) will operate the same as with the original VCR remote control.



TROUBLESHOOTING

No Power

- Check the TV power cord. Unplug the power cord, wait 10 seconds, then reinsert the plug into the outlet and push the POWER button again.
- Check that the outlet is not on a wall switch.
- Be sure the fuse is not blown on the AC power strip if one is being used.

No Picture

- Check the antenna connections. Are they properly secured to the TV's ANT 75Ω plug?
- Check the TUNER MODE control for the correct tuner setting.
- Try running the Auto Program feature to find all available channels.

No Sound

- Check the VOLUME buttons.
- Check the MUTE button on the remote control.
- If you're attempting to hook up auxiliary equipment, check the audio connections to the TV from the other device.

Remote Does Not Work

- Check the batteries. If necessary, replace them with AA

Heavy Duty (Zinc Chloride) or Alkaline batteries.

- Clean the remote control and the remote control sensor on the front of the TV.
- Check the TV power cord. Unplug the power cord, wait 10 seconds, then reinsert the plug into the outlet and push the POWER button again.
- Be sure the fuse is not blown on the AC power strip, if one is being used.
- Check to be sure the power outlet is not on a wall switch.

TV Displays Wrong Channel or No Channels Above 13

- Repeat channel selection.
- Add the desired channel numbers (using the CHANNEL EDIT control) into the TV's memory.
- Check to be sure TUNER MODE is set to CABLE if you have Cable TV service. Run the Auto Program feature to find all available channels. Channels 1-125 can be possible only if you have Cable TV service. If you are using an Antenna, only channels 2-69 can be possible.



CARE AND CLEANING

WARNING Concerning Stationary Images on the TV Screen:

Do not leave stationary or letterbox images on the screen for extended periods of time. This can cause uneven picture tube aging.

Normal use of the TV should involve showing pictures that contain constantly moving and changing images that fill the screen. Do not leave non-moving images on the screen for extended periods of time or display the same images on the screen too frequently. Subtle ghost images can be left on the picture tube. Sources of stationary images may be DVDs, laser discs, video games, CD-i discs, videotapes, digital television boxes, broadcast channels, cable channels, satellite channels, and others.

Here are some examples of stationary images. (This is not an all-inclusive list; you may encounter others in your viewing.)

- **DVD menus**—listings of DVD content
- **Letterbox black bars**—shown at the top and bottom of the TV screen when a wide screen (16:9) movie is viewed on a TV with a standard (4:3) aspect ratio.
- **Video game images and scoreboards**
- **Television station logos**—present a problem if they are bright and stationary; moving or low-contrast graphics are less likely to cause uneven aging of the picture tube
- **Stock-market tickers**—presented at the bottom of the TV screen
- **Shopping channel logos and pricing displays**—bright and show constantly or repeatedly in the same location on the TV screen.

PLACEMENT OF THE TV

- To avoid cabinet warping, cabinet color changes, and increased chance of set failure, do not place the TV where temperatures can become excessively hot (for example, in direct sunlight or near a heating appliance).
- Be sure to allow a free flow of air to and from the perforated back cover of the set.

CLEANING

- To avoid possible shock hazard, be sure the TV is unplugged from the electrical outlet before cleaning.
- Regularly dust the TV with a dry, non-scratching duster to keep the TV clean.
- When cleaning the TV, take care not to scratch or damage the screen surface. Avoid wearing jewelry or using anything abrasive. Do not use household cleaners. Wipe the front screen with a clean cloth dampened with water. Use even, easy, vertical strokes when cleaning.
- Gently wipe the cabinet surfaces with a clean cloth or sponge dampened in a solution of cool, clear water and a mild soap or detergent. Use a clean, dry cloth to dry the wiped surfaces.
- Occasionally vacuum the ventilation holes or slots in the back cover of the set.
- Never use thinners, insecticide sprays, or other chemicals on or near the cabinet, as they might cause permanent marring of the cabinet finish.

GLOSSARY OF TERMS



Audio/Video Inputs • These connectors (phono type plug) receive audio and video signals from VCRs or other devices.

Auto Program • The procedure of adding or deleting channel numbers into the Television's memory. The Television "remembers" only the locally available or desired channel numbers and skips over any unwanted channel numbers.

Closed Caption • Broadcast standard which allows you to read the voice content of television programs on the TV screen. Designed to help the hearing impaired, this feature uses on-screen "text boxes" to show dialog and conversations while the TV program is in progress.

Coaxial Cable • A single solid antenna wire normally matched with a metal (F-type) connector that screws (or pushes) directly onto a 75 Ohm input found on the Television or VCR.

Menu • An on-screen listing of feature controls that are available for adjustment.

On-screen Displays (OSD) • The wording or messages generated by the television to help the user with specific feature controls (color adjustment, programming, etc.).

Remote Sensor • A window or opening on the Television control panel through which infrared remote control signals are received.

Status/Exit • Allows the user to quickly confirm the current channel number. Status can also be used to clear the Television of on-screen displays or information (rather than waiting for the displays to "time out" or automatically disappear from the screen).

Surf • Scanning specific channels in a limited channel list.

Tuner Mode • Designed for first time set up and use where the TV is set for antenna or cable TV signal connections.

Twin Lead Wire • The more commonly used name for the two strand 300 Ohm antenna wire used with many indoor and outdoor antenna systems. In many cases this type of antenna wire requires an additional adapter (or balun) in order to connect to the 75 Ohm Input terminals on recent Televisions and VCRs.

INDEX



Alternate Channel Control	29	Safety Information	3
Audio/Video Input Jacks	23	SAP (Secondary Audio Program) Control	11
Audio/Video Input Jacks located on the Side of the TV	23	Sharpness Control	5
Audio/Video (Monitor) Output Jacks	24	Sleeptimer Control	26
AVL (Automatic Volume Leveler) Control	9	SmartLock	
Balance Control	8	Access Code	15
Bass Control	8	Block All Channels	18
Brightness Control	5	Blocking Channels	16
Closed Caption Control	22	Blocking Options	21
Color Control	5	Clear All Blocked Channels	17
Color Temperature Control	5	Definitions/Understanding SmartLock	14
Contrast + (Black Stretch) Control	7	Movie Ratings	19
DNR (Dynamic Noise Reduction) Control	6	TV Ratings	20
Factory Service Information	38-39	SmartPicture Control	27
Glossary of Terms	37	SmartSound Control	28
Incredible Surround Control	10	Sound Control	12
Index	37	Stereo/Mono Settings	12
Picture Controls	5	Surf Control	29
Registration Information	2	Table of Contents	4
Remote Control Use with Accessory Devices:		Timer Controls	13
Code Entry Method	31	Tint Control	5
Code List	33-34	Treble Control	8
Search Method	32	Troubleshooting Tips	36
VCR Related Buttons	35	Warranty	40
S-Video Input Jack	25		



FACTORY SERVICE LOCATIONS

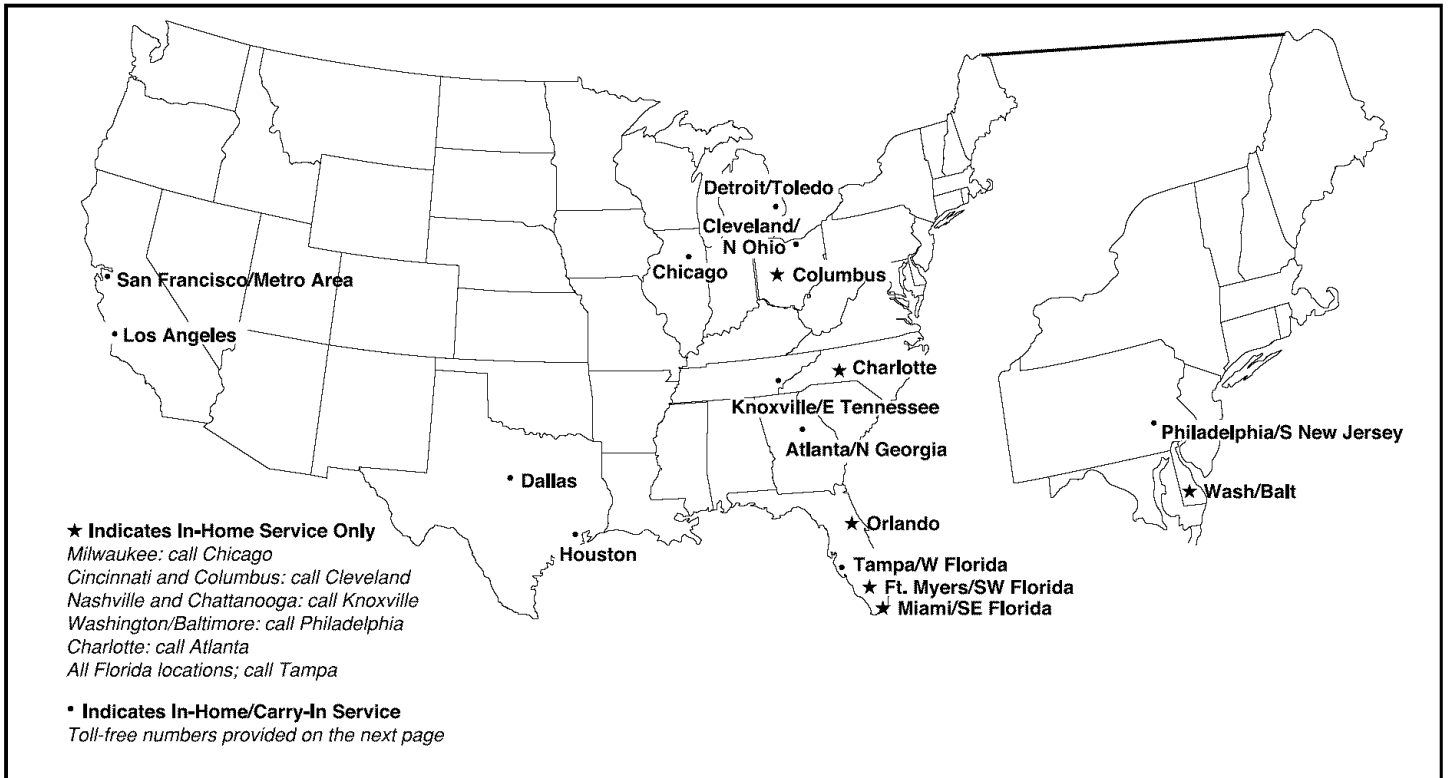

NOTE: Magnavox has chosen Philips Factory Service as its preferred, authorized servicer. Please contact a Philips Factory Service Center. If you reside in one of our Philips Factory Service Branch areas, you can contact the nearest Service Branch to obtain efficient and expedient repair for your product. If your product is In-Warranty, you should have proof-of-purchase to ensure No Charge Service. For Out-of-Warranty service, call the location nearest you.

NOTA: Si vous résidez dans une des régions desservies par une succursale de service après vente du fabricant Philips (voir liste ci-dessous), vous pourrez contacter la branche de service après vente la plus près de chez vous pour obtenir un service après vente rapide et efficace. Si le produit est sous garantie, il suffira de présenter une preuve d'achat pour bénéficier d'un service sans frais. Pour les produits non couverts par la garantie, contactez le centre le plus près de chez vous.

NOTA: Si Ud. reside en una de nuestras zonas para sucursales Philips de servicio al de fábrica (ver directorio más abajo), Ud. puede comunicarse con la sucursal de servicio más cercana para obtener una reparación oportuna y eficaz de su producto. Si su producto está todavía bajo garantía, Ud. debe presentar comprobante de compra para no ocasionar ningunos cargos por servicio. Para servicio después del vencimiento de la garantía, llame al lugar más cercano de los abajo indicados.

In Canada

To obtain efficient and expedient carry-in, mail-in, or in-home service for your product, please contact Magnavox at:

1-800-661-6162 (French speaking)
1-800-705-2000 (English or Spanish speaking)

Au Canada

Comment obtenir le service après-vente pour les produits apportés ou envoyés par la poste à notre centre de service ou le service à domicile, veuillez contacter Magnavox à:

1-800-661-6162 (Francophone)
1-800-705-2000 (Anglais ou Espagnol)

En el Canadá

Cómo recibir servicio eficiente para su producto, en persona, por correo o a domicilio, favor de comunicarse con Magnavox al:

1-800-661-6162 (francófono)
1-800-705-2000 (Inglés o Español))

FACTORY SERVICE LOCATIONS



QUALITY SERVICE IS AS CLOSE AS YOUR TELEPHONE! SIMPLY LOOK OVER THE LIST BELOW FOR THE NUMBER OF A FACTORY SERVICE CENTER NEAR YOU. MAGNAVOX HAS CHOSEN PHILIPS FACTORY SERVICE AS ITS PREFERRED, AUTHORIZED SERVICER. YOUR PRODUCT WILL RECEIVE EFFICIENT AND EXPEDIENT CARRY-IN, MAIL-IN, OR IN-HOME SERVICE, AND YOU WILL RECEIVE PEACE OF MIND, KNOWING YOUR PRODUCT IS BEING GIVEN THE EXPERT ATTENTION OF PHILIPS' FACTORY SERVICE.

COMMENT OBTENIR NOTRE SERVICE APRÈS VENTE RAPIDE ET EFFICACE SOIT PAR COURRIER, À DOMICILE, OU EN SE PRÉSENTANT À UN CENTRE DE SERVICE PHILIPS. PLUS DE 600 CENTRES DE RÉCEPTION DE PRODUITS À RÉPARER À TRAVERS LE PAYS: CONTACTER LE CENTRE DE SERVICE AUX CONSOMMATEURS LE PLUS PROCHE POUR SAVOIR L'EMPLACEMENT DE CES DÉPÔTS DANS UN RAYON DE 50 À 75 MILES (80 KM À 120 KM) DU CENTRE DE SERVICE LOCAL.

CÓMO OBTENER UN SERVICIO OPORTUNO Y EFICIENTE POR CORREO, EN CASA O EN PERSONA PARA SU PRODUCTO A TRAVÉS DE UN CENTRO PHILIPS DE SERVICIO. MAS DE 600 SITIOS POR TODO EL PAIS PARA LA RECEPCION DE PRODUCTOS NECESITADOS DE REPARACIONES: COMUNICARSE CON EL CENTRO DE SERVICIO DE FABRICA MAS CERCANO PARA ESTOS LUGARES DENTRO DE UN RADIO DE 80 A 120 KM (50 A 75 MILLAS) DEL CENTRO DE SERVICIO LOCAL.

ATLANTA

Philips Factory Service
550 Franklin Road., Suite F
Marietta, GA 30067
800-273-1501

TAMPA

Philips Factory Service
1911 US Highway 301 North, Suite 100
Tampa, FL 33619
800-442-2027

SAN FRANCISCO

Philips Factory Service
681 East Brokaw Rd.
San Jose, CA 95112
800-300-9013

HOUSTON

Philips Factory Service
1110 N. Post Oak Rd., Suite 100
Houston, TX 77055
800-952-3254

CLEVELAND

Philips Factory Service
950 Keynote Circle
Brooklyn Heights, OH 44131
800-331-7037

DETROIT

Philips Factory Service
25173 Dequindre
Madison Heights, MI 48071
800-438-1398

DALLAS

Philips Factory Service
415 N. Main Street, #107
Euless, TX 76040
800-952-3254

LOS ANGELES

Philips Factory Service
20930 Bonita, Ste. V
Carson, CA 90746
800-300-9013

CHICAGO

Philips Factory Service
1279 W. Hamilton Pkwy.
Itasca, IL 60143
800-531-2922

KNOXVILLE

Philips Factory Service
One Philips Drive
Building 2
Knoxville, TN 37914
800-821-1767

PHILADELPHIA

Philips Factory Service
354 Dunks Ferry Rd.
Bensalem, PA 19020
800-847-9320

LIMITED WARRANTY

COLOR TELEVISION

90 Days Free Labor

One Year Parts Exchange (Two Years Free Replacement on Color Picture Tube)

This product can be repaired in-home.

WHO IS COVERED?

You must have proof of purchase to receive warranty service. A sales receipt or other document showing that you purchased the product is considered proof of purchase.

WHAT IS COVERED?

Warranty coverage begins the day you buy your product. For 90 days thereafter, all parts will be repaired or replaced free, and labor is free. From 90 days to one year from the day of purchase, all parts will be repaired or replaced free, but you pay for all labor charges. From one to two years from the day of purchase, you pay for the replacement or repair of all parts except the picture tube, and for all labor charges. After two years from the day of purchase, you pay for the replacement or repair of all parts, and for all labor charges.

All parts, including repaired and replaced parts, are covered only for the original warranty period. When the warranty on the product expires, the warranty on all replaced and repaired parts also expires.

WHAT IS EXCLUDED?

Your warranty does not cover:

- labor charges for installation or setup of the product, adjustment of customer controls on the product, and installation or repair of antenna systems outside of the product.
- product repair and/or part replacement because of misuse, accident, unauthorized repair or other cause not within the control of Magnavox.
- reception problems caused by signal conditions or cable or antenna systems outside the unit.
- a product that requires modification or adaptation to enable it to operate in any country other than the country for which it was designed, manufactured, approved and/or authorized, or repair of products damaged by these modifications.
- incidental or consequential damages resulting from the product. (Some states do not allow the exclusion of incidental or consequential damages, so the above exclusion may not apply to you. This includes, but is not limited to, prerecorded material, whether copyrighted or not copyrighted.)
- a product used for commercial or institutional purposes.

WHERE IS SERVICE AVAILABLE?

Warranty service is available in all countries where the product is officially distributed by Magnavox. In countries where Magnavox does not distribute the product, the local Magnavox service organization will attempt to provide service (although there may be a delay if the appropriate spare parts and technical manual(s) are not readily available).

MAKE SURE YOU KEEP...

Please keep your sales receipt or other document showing proof of purchase. Attach it to this owner's manual and keep both nearby. Also keep the original box and packing material in case you need to return your product.

BEFORE REQUESTING SERVICE...

Please check your owner's manual before requesting service. Adjustments of the controls discussed there may save you a service call.

TO GET WARRANTY SERVICE IN U.S.A., PUERTO RICO, OR U.S. VIRGIN ISLANDS...

Contact a Magnavox factory service center (see enclosed list) or authorized service center to arrange repair.

(In U.S.A., Puerto Rico, and U.S. Virgin Islands, all implied warranties, including implied warranties of merchantability and fitness for a particular purpose, are limited in duration to the duration of this express warranty. But, because some states do not allow limitations on how long an implied warranty may last, this limitation may not apply to you.)

TO GET WARRANTY SERVICE IN CANADA...

Please contact Magnavox at:

1-800-705-2000

(In Canada, this warranty is given in lieu of all other warranties. No other warranties are expressed or implied, including any implied warranties of merchantability or fitness for a particular purpose. Magnavox is not liable under any circumstances for any direct, indirect, special, incidental or consequential damages, howsoever incurred, even if notified of the possibility of such damages.)

REMEMBER...

Please record below the model and serial numbers found on the product. Also, please fill out and mail your warranty registration card promptly. It will be easier for us to notify you if necessary.

MODEL # _____
SERIAL # _____

This warranty gives you specific legal rights. You may have other rights which vary from state/province to state/province.

Magnavox, P.O. Box 520890, Miami, FL 33152 (402) 536-4171

EL6552E001 / 3-03