

Visit www.carrier.com

Installation and Start-Up Instructions

NOTE: Read the entire instruction manual before starting the installation.

This symbol → indicates a change since the last issue.

SAFETY CONSIDERATIONS

Improper installation, adjustment, alteration, service, maintenance, or use can cause explosion, fire, electrical shock, or other conditions which may cause death, personal injury, or property damage. Consult a qualified installer, service agency, or your distributor or branch for information or assistance. The qualified installer or agency must use factory-authorized kits or accessories when modifying this product. Refer to the individual instructions packaged with the kits or accessories when installing.

Follow all safety codes. Wear safety glasses, protective clothing, and work gloves. Use quenching cloth for brazing operations. Have fire extinguisher available. Read these instructions thoroughly and follow all warnings or cautions included in literature and attached to the unit. Consult local building codes and National Electrical Code (NEC) for special requirements.

Recognize safety information. This is the safety-alert symbol . When you see this symbol on the unit and in instructions or manuals, be alert to the potential for personal injury.

Understand the signal words DANGER, WARNING, and CAUTION. These words are used with the safety-alert symbol. DANGER identifies the most serious hazards which **will** result in severe personal injury or death. WARNING signifies hazards which **could** result in personal injury or death. CAUTION is used to identify unsafe practices which **would** result in minor personal injury or product and property damage. NOTE is used to highlight suggestions which **will** result in enhanced installation, reliability, or operation.

WARNING

Before installing, modifying, or servicing system, main electrical disconnect switch must be in the OFF position. There may be more than 1 disconnect switch. Lock out and tag switch(es) with a suitable warning label. Electrical shock can cause personal injury or death.

INTRODUCTION AND RECOMMENDATIONS

NOTE: In some cases noise has been traced to improper installation of equipment.

1. Locate unit away from windows, patios, decks, and so forth where unit operation sounds may disturb customer.
2. Ensure that vapor- and liquid-tube diameters are appropriate to capacity of unit.
3. Run refrigerant tubes as directly as possible by avoiding unnecessary turns and bends.
4. Leave some slack between structure and unit to absorb vibration.
5. When passing refrigerant tubes through the wall, seal opening with RTV or other pliable silicon-based caulk. (See Fig. 3.)

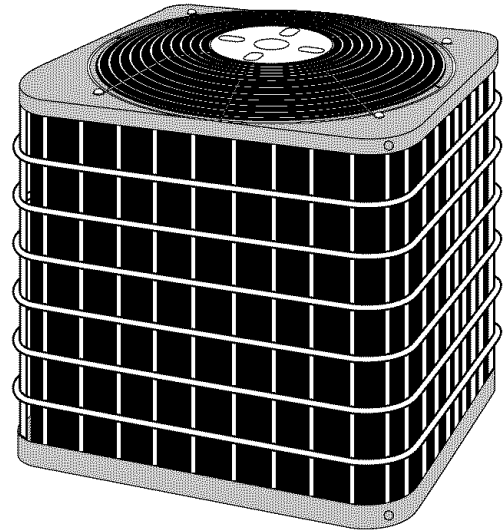

A97005

Fig. 1—Model 38YCC

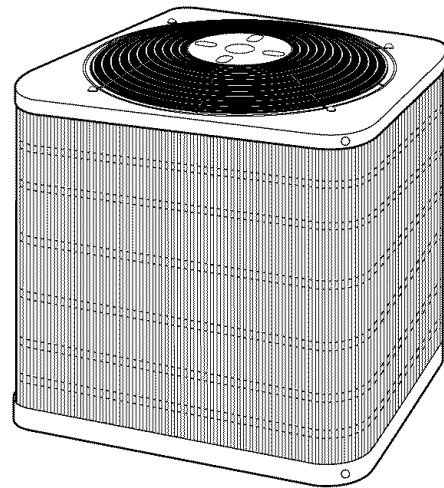

A98525

Fig. 2—Models 38YCG and 38YCS

6. Avoid direct refrigerant tubing contact with water pipes, duct work, floor joists, wall studs, floors, and walls.
7. Do not suspend refrigerant tubing from joists and studs with a rigid wire or strap that comes in direct contact with tubing. (See Fig. 3.)
8. Ensure that refrigerant tubing insulation is pliable and completely surrounds vapor tube.
9. When necessary, use hanger straps which are 1 in. wide and conform to shape of tubing insulation. (See Fig. 3.)
10. Isolate hanger straps from insulation by using metal sleeves bent to conform to shape of insulation.

NOTE: Avoid contact between tubing and structure

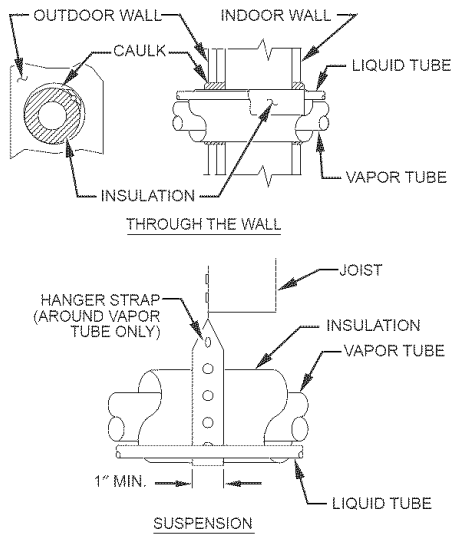

A94028

Fig. 3—Connecting Tubing Installation

When outdoor unit is connected to factory-approved indoor unit, outdoor unit contains system-refrigerant charge for operation with indoor unit of the same size when connected by 15 ft of field-supplied or factory-accessory tubing. For proper unit operation, check refrigerant charge using charging information located on control-box cover and/or in the Check Charge section of this Instruction.

- **IMPORTANT:** Maximum liquid-line size is 3/8-in. O.D. for all residential applications including long line applications.
- **IMPORTANT:** Always install a liquid-line filter drier on any system using an existing field service lineset and/or existing indoor coil. Also, always use liquid line filter driers on burnout compressor replacements. Refer to Product Data Digest for appropriate part number. Obtain filter drier from your distributor or branch.

INSTALLATION

Step 1—Check Equipment and Job Site

UNPACK UNIT

Move to final location. Remove carton, taking care not to damage unit.

INSPECT EQUIPMENT

File claim with shipping company prior to installation if shipment is damaged or incomplete. Locate unit-rating plate on unit-service panel. It contains information needed to properly install unit. Check rating plate to be sure unit matches job specifications.

Step 2—Install on a Solid, Level Mounting Pad

If conditions or local codes require the unit be attached to pad, tie-down bolts should be used and fastened through knockouts provided in unit base pan. Refer to unit-mounting pattern in Fig. 4 to determine base-pan size and knockout-hole location.

On rooftop applications, mount on level platform or frame 6 in. above roof surface. Place unit above a load-bearing wall and isolate unit and tubing set from structure. Arrange supporting members to adequately support unit and minimize transmission of vibration to building. Consult local codes governing rooftop applications.

Roof-mounted units exposed to winds above 5 mph may require wind baffles to achieve adequate defrost. Consult Low-Ambient Guideline for wind-baffle construction.

NOTE: Unit must be level to within $\pm 2^\circ$ ($\pm 3/8$ in./ft) per compressor manufacturer specifications.

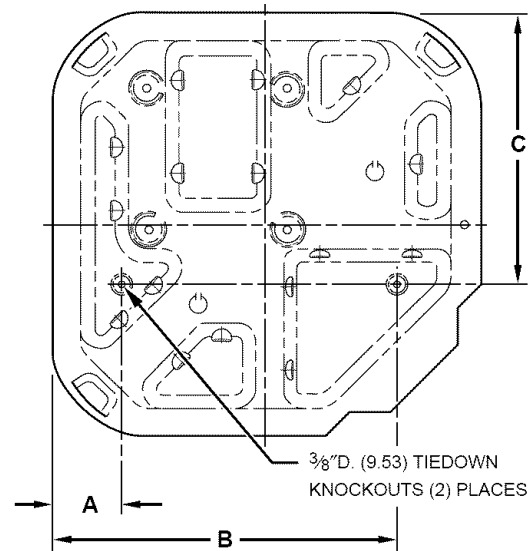

A94199

Dimensions (In.)

UNIT SIZE	MINIMUM MOUNTING-PAD DIMENSIONS	TIEDOWN KNOCKOUT LOCATIONS		
		A	B	C
018-030	22-1/2 x 22-1/2	3-11/16	18-1/8	14-3/8
036-060	30 x 30	6-1/2	23-1/2	20

Fig. 4—Mounting Unit to Pad

Step 3—Clearance Requirements

When installing, allow sufficient space for airflow clearance, wiring, refrigerant piping, and service. Allow 30-in. clearance to service end of unit and 48 in. above unit. For proper airflow, a 6-in. clearance on 1 side of unit and 12 in. on all remaining sides must be maintained. Maintain a distance of 24 in. between units. Position so water, snow, or ice from roof or eaves cannot fall directly on unit.

On rooftop applications, locate unit at least 6 in. above roof surface.

Step 4—Operating Ambients

The minimum outdoor-operating ambient in cooling mode is 55°F, and the maximum outdoor-operating ambient in cooling mode is 125°F. The maximum outdoor-operating ambient in heating mode is 66°F.

Step 5—Elevate Unit

⚠ CAUTION

Accumulation of water and ice in base pan may cause equipment damage.

In areas where prolonged freezing temperatures are encountered, elevate unit per local climate and code requirements to provide clearance above estimated snowfall level and ensure adequate drainage of unit.

Step 6—Check Indoor And Outdoor AccuRater® Piston

Check indoor-coil piston to see if it matches the required piston shown on outdoor unit-rating plate. If it does not match, replace indoor-coil piston with piston shipped with outdoor unit. The piston shipped with outdoor unit is correct for any approved indoor-coil combination.

Table 1—Refrigerant Connections and Recommended Liquid- and Vapor-Tube Diameters (In.)

UNIT SIZE	LIQUID		VAPOR		VAPOR (LONG LINE)	
	Connection Diameter	Tube Diameter	Connection Diameter	Tube Diameter	Connection Diameter	Tube Diameter
018, 024	3/8	3/8	3/4	3/4	3/4	3/4
030, 036	3/8	3/8	3/4	3/4	3/4	7/8
042, 048	3/8	3/8	7/8	7/8	7/8	1-1/8
060	3/8	3/8	7/8	1-1/8	7/8	1-1/8

NOTES:

1. Tube diameters are for lengths up to 50 ft or 20 ft vertical differential. For tubing lengths greater than 50 ft, consult Long Line section of the Application Guideline.
2. Do not apply capillary-tube indoor coils to these units.

⚠ CAUTION

To avoid equipment damage and/or loss of performance remove indoor-coil piston if unit is to be installed on system with a TXV-metering device.

Step 7—Check Defrost Thermostat

Check defrost thermostat to ensure it is properly located and securely attached. There is a liquid header with a brass distributor and feeder tube going into outdoor coil. At the end of 1 of the feeder tubes, there is a 3/8-in. O.D. stub tube approximately 3 in. long. The defrost thermostat should be located on stub tube. Note that there is only 1 stub tube used with liquid header, and on most units it is the bottom circuit.

Step 8—Make Piping Connections

⚠ WARNING

Relieve pressure and recover all refrigerant before system repair or final unit disposal to avoid personal injury or death. Use all service ports and open all flow-control devices, including solenoid valves.

⚠ CAUTION

If ANY refrigerant tubing is buried, provide a 6 in. vertical rise at service valve to avoid equipment damage. Refrigerant tubing lengths up to 36 in. may be buried without further special consideration. For lengths above 36 in., consult your local distributor.

⚠ CAUTION

To prevent damage to unit or service valves observe the following:

- Use a brazing shield.
- Wrap service valves with wet cloth or use a heat-sink material.

Outdoor units may be connected to indoor section using accessory-tubing package or field-supplied refrigerant-grade tubing of correct size and condition. For tubing requirements beyond 50 ft length or 20 ft vertical differential, substantial capacity and performance losses can occur. Following the recommendations in the Residential Split-System Long-Line Application Guideline will reduce these losses. Refer to Table 1 for field-tubing diameters.

REFRIGERANT TUBING

Connect tubing to fittings on outdoor unit vapor- and liquid-service valves. (See Table 1.) Use refrigerant-grade tubing. Refer to appropriate section below for type of service valves installed on unit.

SWEAT CONNECTION

⚠ CAUTION

To avoid valve damage while brazing, service valves must be wrapped in a heat-sinking material such as a wet cloth.

1. Remove plastic retainer holding outdoor piston in liquid-service valve.
2. Locate adapter tube shipped with unit.
3. Install strainer in adapter tube and connect tube to service valve. (See Fig. 5.)
4. Connect refrigerant tubing to fittings on outdoor-unit vapor- and liquid-service valves.
- 5. Service valves are closed from factory and ready for brazing. After wrapping service valve with a wet cloth, tubing set can be brazed to service valve using either silver-bearing or non-silver-bearing brazing material. Do not use soft solder (material that melts below 800°F). Consult local code requirements.

Refrigerant tubing and indoor coil are now ready for leak testing. This check should include all field and factory joints.

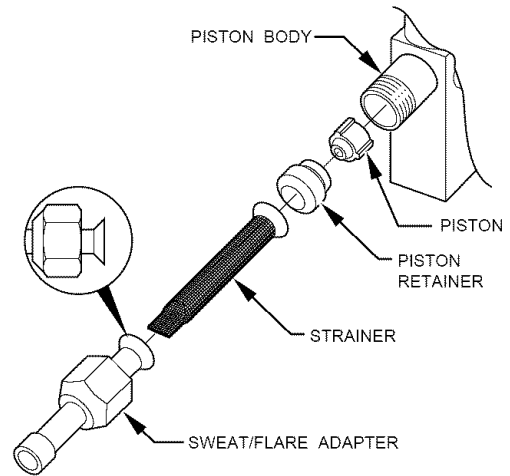

A97512

Fig. 5—Liquid-Service Valve with Sweat-Adapter Tube

FINAL TUBING CHECK

IMPORTANT: Check to be certain factory tubing on both indoor and outdoor unit has not shifted during shipment. Ensure tubes are not rubbing against each other or any sheet metal. Pay close attention to feeder tubes, making sure wire ties on feeder tubes are secure and tight.

Step 9—Make Electrical Connections

⚠ WARNING

To avoid personal injury or death, do not supply power to unit with compressor terminal-box cover removed.

Be sure field wiring complies with local and national fire, safety, and electrical codes, and voltage to system is within limits shown on unit-rating plate. Contact local power company for correction of improper voltage. See unit-rating plate for recommended circuit-protection device.

NOTE: Operation of unit on improper line voltage constitutes abuse and could affect unit reliability. See unit-rating plate. Do not install unit in system where voltage or phase imbalance (3 phase) may fluctuate above or below permissible limits.

NOTE: Use copper wire only between disconnect switch and unit.

NOTE: Install branch-circuit disconnect of adequate size per NEC to handle unit-starting current. Locate disconnect within sight from and readily accessible from unit, per Section 440-14 of NEC.

ROUTE GROUND AND POWER WIRES

Remove access panel and control box to gain access to unit wiring. Extend wires from disconnect through power-wiring hole provided and into unit-control box.

⚠ WARNING

The unit cabinet must have an uninterrupted or unbroken ground to minimize personal injury if an electrical fault should occur. The ground may consist of electrical wire or metal conduit when installed in accordance with existing electrical codes. Failure to follow this warning can result in an electric shock, fire, or death.

CONNECT GROUND AND POWER WIRES

Connect ground wire to ground connection in control box for safety. Connect power wiring to contactor as shown in Fig. 6.

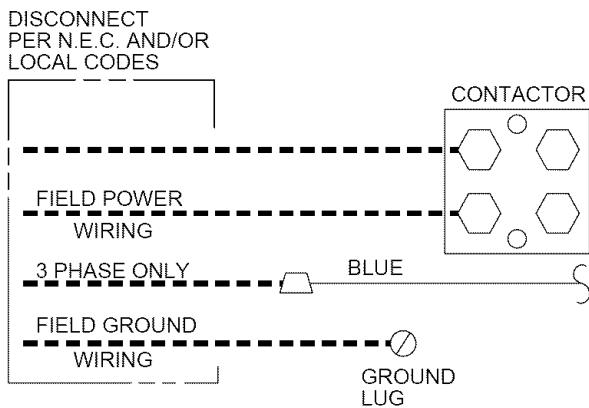

Fig. 6—Line Power Connections

CONNECT CONTROL WIRING

Route 24v control wires through control-wiring grommet and connect leads to control wiring. Refer also to Installation Instructions packaged with thermostat.

Use No. 18 AWG color-coded, insulated (35°C minimum) wire. If thermostat is located more than 100 ft from unit, as measured along the control-voltage wires, use No. 16 AWG color-coded wire to avoid excessive voltage drop.

All wiring must be NEC Class 1 and must be separated from incoming power leads.

Use furnace transformer, fan-coil transformer, or accessory transformer for control power, 24v/40va minimum.

NOTE: Use of available 24v accessories may exceed the minimum 40va power requirement. Determine total transformer loading and increase the transformer capacity or split the load with an accessory transformer as required.

FINAL WIRING CHECK

IMPORTANT: Check factory wiring and field-wire connections to ensure terminations are secured properly. Check wire routing to ensure wires are not in contact with tubing, sheet metal, and so forth.

Step 10—Compressor Crankcase Heater

When equipped with a crankcase heater, furnish power to heater a minimum of 24 hr before starting unit. To furnish power to heater only, set thermostat to OFF and close electrical disconnect to outdoor unit. A crankcase heater is required if refrigerant tubing is longer than 50 ft.

Step 11—Install Electrical Accessories

Refer to the individual instructions packaged with kits or accessories when installing.

Step 12—Start-Up

⚠ CAUTION

To prevent compressor damage or personal injury, observe the following:

- Do not overcharge system with refrigerant.
 - Do not operate unit in a vacuum or at negative pressure.
 - Do not disable low-pressure switch.
- In scroll compressor applications:
- Dome temperatures may be hot.

⚠ CAUTION

To prevent personal injury wear safety glasses, protective clothing, and gloves when handling refrigerant and observe the following:

- Back-seating service valves are not equipped with Schrader valves. Fully back seat (counterclockwise) valve stem before removing gage-port cap.
- Front-seating service valves are equipped with Schrader valves.

⚠ CAUTION

Federal regulations require that you do not vent refrigerant to atmosphere. Recover during system repair or final unit disposal.

If refrigerant tubes or indoor coil are exposed to atmosphere, they must be evacuated to 500 microns to eliminate contamination and moisture in the system.

Follow these steps to properly start up the system:

1. Fully back seat (open) liquid- and vapor-tube service valves.
2. Unit is shipped with valve stem(s) front seated (closed) and caps installed. Replace stem caps after system is opened to refrigerant flow. Replace caps finger-tight and tighten with wrench an additional 1/12 turn.
3. Close electrical disconnects to energize system.
4. Set room thermostat to desired temperature. Be sure set point is below indoor ambient temperature.

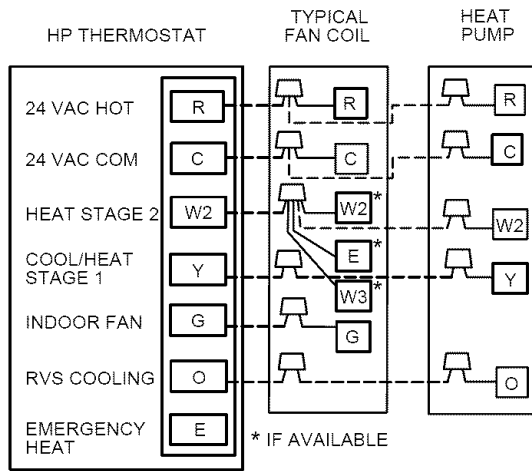

→ **Fig. 7—Generic Wiring Diagram**
(See Thermostat Installation Instructions
for wiring specific unit combinations.)

A02325

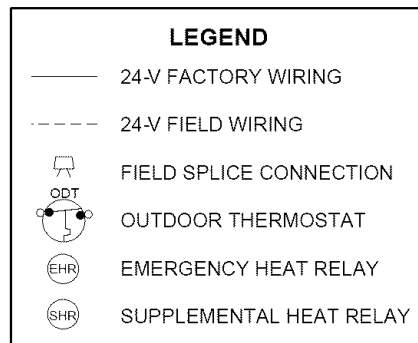

5. Set room thermostat to HEAT or COOL and fan control to ON or AUTO mode, as desired. Operate unit for a minimum of 15 minutes. Check system-refrigerant charge.

⚠ CAUTION

To avoid equipment damage ensure compressor rotation is correct. •3-phase scroll compressors are rotation sensitive.
•A flashing LED on phase monitor indicates reverse rotation. (See Fig. 8 and Table 2.)
This will not allow contactor to be energized.
•Disconnect power to unit and interchange 2 field-wiring leads on unit contactor.

Step 13—Check Charge

Factory charge is shown on unit-rating plate. To check charge in cooling mode, refer to Cooling-Only Procedure on unit wiring and charging label.

COOLING-ONLY PROCEDURE

NOTE: If superheat- or subcooling-charging conditions are not favorable, charge must be weighed in accordance with unit-rating plate ± 0.6 oz/ft of 3/8-in. liquid line above or below 15 ft respectively.

EXAMPLE:

To calculate additional charge required for a 25-ft line set:
 $25 \text{ ft} - 15 \text{ ft} = 10 \text{ ft} \times 0.6 \text{ oz/ft} = 6 \text{ oz}$ of additional charge

HEATING CHECK-CHART PROCEDURE

To check system operation during heating cycle, refer to the Heating Check Chart on outdoor unit. This chart indicates whether

a correct relationship exists between system operating pressure and air temperature entering indoor and outdoor units. If pressure and temperature do not match on chart, system-refrigerant charge may not be correct. Do not use chart to adjust refrigerant charge.

NOTE: When charging is necessary during heating season, charge must be weighed in accordance with unit rating plate ± 0.6 oz/ft of 3/8-in. liquid line above or below 15 ft respectively.

Step 14—Final Checks

IMPORTANT: Before leaving job, be sure to do the following:

1. Securely fasten all panels and covers.
2. Tighten service valve-stem caps to 1/12-turn past finger-tight.
3. Leave User's Manual with owner. Explain system operation and periodic maintenance requirements outlined in manual.
4. Fill out Dealer Installation Checklist and place in customer file.

SEQUENCE OF OPERATION

With power supplied to indoor and outdoor units, transformer is energized.

Cooling

On a call for cooling, thermostat makes circuits R-O, R-Y, and R-G. Circuit R-O energizes reversing valve, switching it to cooling position. On 3-phase models with scroll compressors, the units are equipped with a phase monitor to detect if the incoming power is correctly phased for compressor operation. If phasing is correct, circuit R-Y energizes contactor, starting outdoor-fan motor and compressor circuit. R-G energizes indoor unit-blower relay, starting indoor-blower motor on high speed.

NOTE: If the phasing is incorrect, the contactor will not be energized. To correct the phasing, interchange any 2 of the 3 power connections on the field side.

When thermostat is satisfied, its contacts open, de-energizing the contactor and blower relay. Compressor and motors should stop.

NOTE: If indoor unit is equipped with a time-delay relay circuit, the blower runs an additional 90 sec to increase system efficiency.

Heating

On a call for heating, thermostat makes circuits R-Y and R-G. If phasing is correct, circuit R-Y energizes contactor, starting outdoor-fan motor and compressor. Circuit R-G energizes indoor-blower relay, starting blower motor on high speed.

→ Should temperature continue to fall, R-W2 is made through second-stage room thermostat. Circuit R-W2 energizes relays, bringing on supplemental electric heat. If outdoor thermostat is used (field-installed option), only the first bank will be energized. Remaining bank of supplemental electric heat will be energized when outdoor temperature falls below outdoor thermostat setting.

When thermostat is satisfied, its contacts open, de-energizing contactor and relays. All heaters and motors should stop.

Defrost

The defrost control is a time/temperature control which includes a field-selectable (quick-connects located at board edge) time period between defrost cycles (30, 50, or 90 minutes), factory set at 90 minutes.

Defrost mode is identical to cooling mode except that outdoor-fan motor stops and second-stage heat is turned on to continue warming conditioned space.

→ Initially the defrost cycle timer starts when the contactor is energized and a 24v signal is present on the T1 terminal. Then the defrost cycle begins when the cycle timer times out (30, 50, 90 min) and the defrost thermostat is closed.

To initiate defrost, the defrost thermostat must be closed. This can be accomplished as follows:

1. Turn off power to outdoor unit.

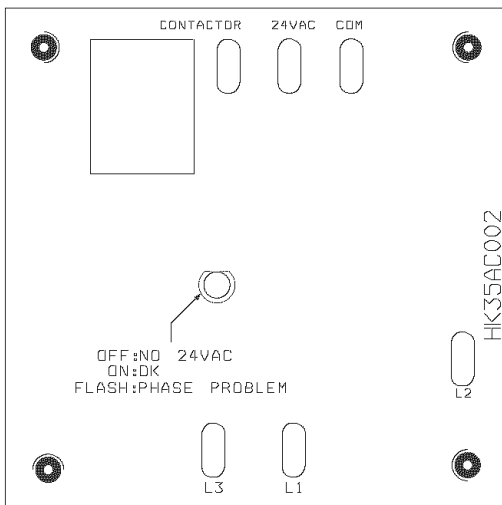
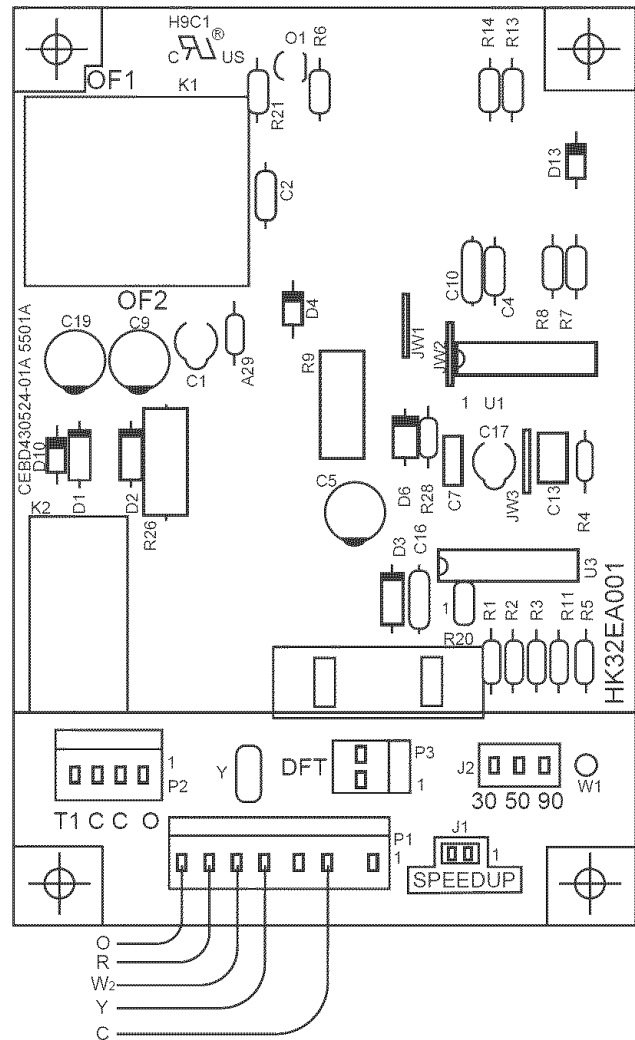

Table 2—Phase-Monitor LED Indicators

LED	STATUS
OFF	No call for compressor operation
FLASHING	Reversed phase
ON	Normal

Fig. 8—Phase-Monitor Control



A02001

Table 3—Defrost Control Speedup-Timing Sequence

PARAMETER	MINIMUM (MINUTES)	MAXIMUM (MINUTES)	SPEEDUP (NOMINAL)
30-minute cycle	27	33	7 sec
50-minute cycle	45	55	12 sec
90-minute cycle	81	99	21 sec
10-minute cycle	9	11	2 sec
5 minutes	4.5	5.5	1 sec

→ **Fig. 9—Defrost Control**

2. Disconnect outdoor-fan motor lead from OF2 on control board. (See Fig. .) Tape lead to prevent grounding.
3. Restart unit in heating mode, allowing frost to accumulate on outdoor coil.
4. After a few minutes in heating mode, liquid-line temperature should drop below closing point of defrost thermostat (approximately 30°F).
5. Short between speed-up terminals with a flat-bladed screwdriver. (See Fig. 9.) This reduces the timing sequence to 1/256th of original time. (See Table 3.)
6. When you hear reversing valve change position, remove screwdriver immediately; otherwise, control will terminate normal 10-minute defrost cycle in approximately 2 sec.

NOTE: Length of defrost cycle is dependent upon length of time it takes to remove screwdriver from test pins after reversing valve has shifted.

7. Unit will remain in defrost for remainder of defrost-cycle time or until defrost thermostat reopens at approximately 80°F coil temperature of liquid line.
8. Turn off power to outdoor unit and reconnect fan-motor lead to OF2 on control board. (See Fig. 9.)

CARE AND MAINTENANCE

For continuing high performance and to minimize possible equipment failure, periodic maintenance must be performed on this equipment.

Frequency of maintenance may vary depending upon geographic areas, such as coastal applications.

Manufacturer reserves the right to discontinue, or change at any time, specifications or designs without notice and without incurring obligations.