

Visit [www.carrier.com](http://www.carrier.com)

## Installation and Start-Up Instructions

**NOTE:** Read the entire instruction manual before starting the installation.

This symbol → indicates a change since the last issue.

### SAFETY CONSIDERATIONS

Improper installation, adjustment, alteration, service, maintenance, or use can cause explosion, fire, electrical shock, or other conditions which may cause death, personal injury, or property damage. Consult a qualified installer, service agency, or your distributor or branch for information or assistance. The qualified installer or agency must use factory-authorized kits or accessories when modifying this product. Refer to the individual instructions packaged with the kits or accessories when installing.

Follow all safety codes. Wear safety glasses, protective clothing, and work gloves. Use quenching cloth for brazing operations. Have fire extinguisher available. Read these instructions thoroughly and follow all warnings or cautions included in literature and attached to the unit. Consult local building codes and National Electrical Code (NEC) for special requirements.

Recognize safety information. This is the safety-alert symbol . When you see this symbol on the unit and in instructions or manuals, be alert to the potential for personal injury.

Understand the signal words DANGER, WARNING, and CAUTION. These words are used with the safety-alert symbol. DANGER identifies the most serious hazards which **will** result in severe personal injury or death. WARNING signifies hazards which **could** result in personal injury or death. CAUTION is used to identify unsafe practices which **would** result in minor personal injury or product and property damage. NOTE is used to highlight suggestions which **will** result in enhanced installation, reliability, or operation.

#### WARNING

Before installing, modifying, or servicing system, main electrical disconnect switch must be in the OFF position. There may be more than 1 disconnect switch. Lock out and tag switch with a suitable warning label. Electrical shock can cause personal injury or death.

#### CAUTION

Puron® (R-410A) systems operate at higher pressures than standard R-22 systems. Be certain that service equipment is rated for Puron®. Some R-22 service equipment may not be acceptable. Check with your distributor.

### INSTALLATION RECOMMENDATIONS

**NOTE:** In some cases noise in the living area has been traced to gas pulsations from improper installation of equipment.

1. Locate unit away from windows, patios, decks, etc. where unit operation sound may disturb customer.
2. Ensure that vapor and liquid tube diameters are appropriate to capacity of unit.

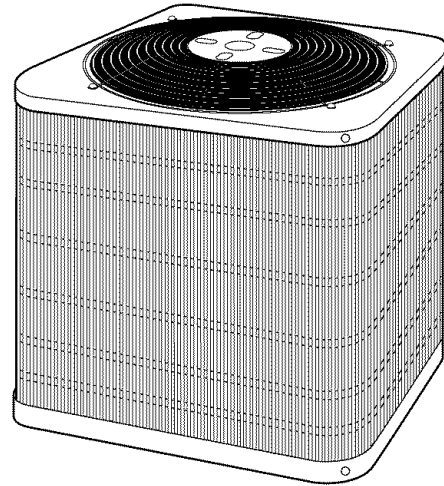

A98525

**Fig. 1—Model 38EYG**

3. Run refrigerant tubes as directly as possible by avoiding unnecessary turns and bends.
4. Leave some slack between structure and unit to absorb vibration.
5. When passing refrigerant tubes through the wall, seal opening with RTV or other pliable silicon-based caulk. (See Fig. 2.)
6. Avoid direct tubing contact with water pipes, duct work, floor joists, wall studs, floors, and walls.
7. Do not suspend refrigerant tubing from joists and studs with a rigid wire or strap which comes in direct contact with tubing. (See Fig. 2.)
8. Ensure that tubing insulation is pliable and completely surrounds vapor tube.
9. When necessary, use hanger straps which are 1 in. wide and conform to shape of tubing insulation. (See Fig. 2.)
10. Isolate hanger straps from insulation by using metal sleeves bent to conform to shape of insulation.

When outdoor unit is connected to factory-approved indoor unit, outdoor unit contains system refrigerant charge for operation with indoor unit of same size when connected by 15 ft of field-supplied or factory accessory tubing. Add (or subtract) 0.6 oz/ft of 3/8 liquid line for lengths greater (or less) than 15 ft. For proper unit operation, check refrigerant charge using charging information located on control box cover and/or in the Check Charge section of this instruction.

**IMPORTANT:** Maximum liquid-line size is 3/8-in. O.D. for all residential applications including long line.

**IMPORTANT:** Always install the factory-supplied Puron® heat pump (bi-flow) liquid-line filter drier. If replacing the filter drier, refer to Product Data Digest for appropriate part number. Obtain replacement filter driers from your distributor or branch.

**NOTE:** Avoid contact between tubing and structure

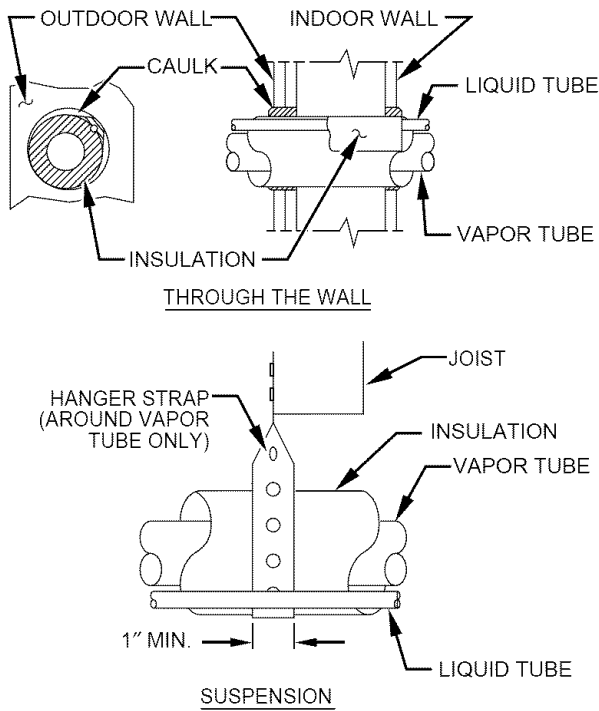

A94028

**Fig. 2—Connecting Tubing Installation**  
**INSTALLATION**

**IMPORTANT:** Specifications for this unit in residential new construction market require using the outdoor unit, indoor unit, refrigerant tubing sets, metering device, and filter drier listed in presale literature. There can be no deviation. Consult the Application Guideline and Service Manual for Residential Split-System Air Conditioners and Heat Pumps using Puron® Refrigerant to obtain required unit changes for specific applications and for R-22 retrofit.

**Step 1—Check Equipment and Job Site**

**UNPACK UNIT**

Move to final location. Remove carton taking care not to damage unit.

**INSPECT EQUIPMENT**

File claim with shipping company prior to installation if shipment is damaged or incomplete. Locate unit rating plate on unit corner panel. It contains information needed to properly install unit. Check rating plate to be sure unit matches job specifications.

**Step 2—Install On a Solid, Level Mounting Pad**

If conditions or local codes require the unit be attached to pad, tie down bolts should be used and fastened through knockouts provided in unit base pan. Refer to unit mounting pattern in Fig. 3 to determine base pan size and knockout hole location.

On rooftop applications, mount on level platform or frame. Place unit above a load-bearing wall and isolate unit and tubing set from structure. Arrange supporting members to adequately support unit and minimize transmission of vibration to building. Consult local codes governing rooftop applications.

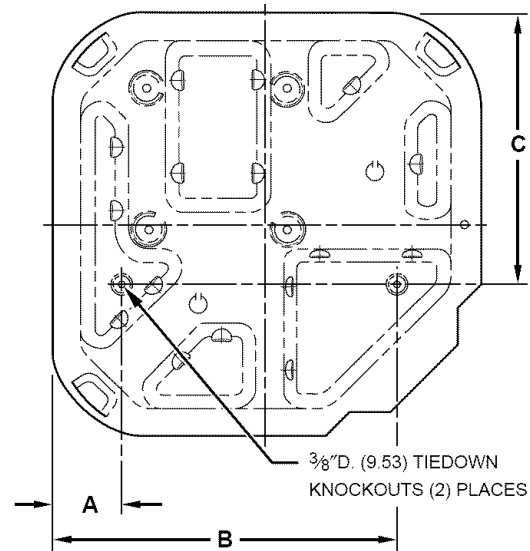

A94199

**DIMENSIONS (IN.)**

UNIT SIZE	MINIMUM MOUNTING PAD DIMENSIONS	TIEDOWN KNOCKOUT LOCATIONS		
		A	B	C
018, 024, 030	22-1/2 X 22-1/2	3-11/16	18-1/8	14-3/8
036-060	30 X 30	6-1/2	23-1/2	20

**Fig. 3—Mounting Unit to Pad**

**⚠ CAUTION**

Do not allow POE lubricant to come into contact with roofing material. POE may deteriorate certain types of synthetic roofing.

Roof mounted units exposed to winds above 5 mph may require wind baffles. Consult the Application Guideline and Service Manual for Residential Split-System Air Conditioners and Heat Pumps using Puron® Refrigerant for wind baffle construction.

**NOTE:** Unit must be level to within  $\pm 2^\circ$  ( $\pm 3/8$  in./ft) per compressor manufacturer specifications.

**Step 3—Clearance Requirements**

When installing, allow sufficient space for airflow clearance, wiring, refrigerant piping, and service. Allow 30-in. clearance to service end of unit and 48 in. above unit. For proper airflow, a 6-in. clearance on 1 side of unit and 12 in. on all remaining sides must be maintained. Maintain a distance of 24 in. between units. Position so water, snow, or ice from roof or eaves cannot fall directly on unit.

On rooftop applications, locate unit at least 6 in. above roof surface.

**Step 4—Operating Ambient**

The minimum outdoor operating ambient in cooling mode without additional accessories is 55°F, and the maximum outdoor operating ambient in cooling mode is 125°F. The maximum outdoor operating ambient in heating mode is 66°F.

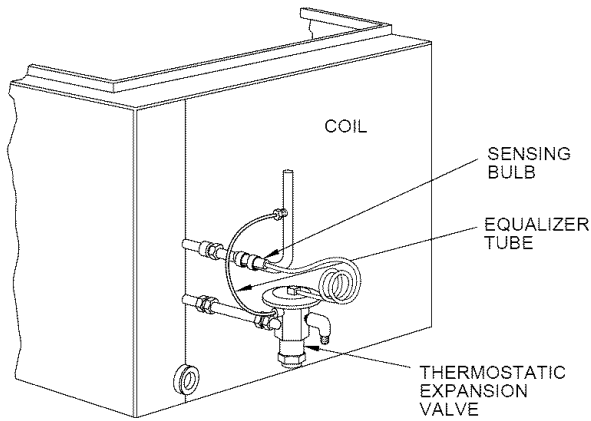

**Fig. 4—Typical TXV Installation**

A81277

**Step 5—Elevate Unit**

**⚠ CAUTION**

Accumulation of water and ice in base pan may cause equipment damage.

Elevate unit per local climate and code requirements to provide clearance above estimated snowfall level and ensure adequate drainage of unit.

**Step 6—Check Indoor Expansion Device**

**⚠ CAUTION**

For proper unit operation and reliability, units must be installed with hard shutoff TXV specifically designed to operate with Puron®. Do not use R-22 TXV. Do not install with evaporator coils having capillary tube metering devices or pistons.

For TXV kit part number and charging instructions, refer to TXV label in outdoor unit.

**FURNACE COILS**

If TXV installation is required, remove existing AccuRater® from indoor coil. Refer to Fig. 4 and 5 and install TXV kit (specifically designed for Puron®) as follows:

1. Install suction tube adapter.
2. Install liquid flare-to-sweat adapter.
3. Connect external equalizer tube to fitting on suction tube adapter.
4. Position sensing bulb on horizontal portion of suction tube adapter. Secure using supplied hardware.
5. Insulate bulb after installation. (See Fig. 5.)
6. Leak check all connections.

**FAN COILS**

If indoor unit (fan coil) comes factory equipped with a bi-flow hard shutoff TXV specifically designed for Puron®, no TXV change is required.

If fan coil is not designed for Puron®, a Puron® TXV installation is required. Refer to TXV kit Installation Instructions for details on TXV installation.

**Step 7—Check Defrost Thermostat**

Check defrost thermostat to ensure it is properly located and securely attached. There is a liquid header with a brass distributor

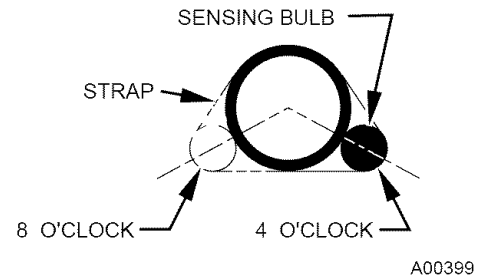

A00399

**Fig. 5—Positioning of Sensing Bulb**

and feeder tube going into outdoor coil. At the end of 1 of the feeder tubes, there is a 3/8-in. OD stub tube approximately 3 in. long. (See Fig. 6.) The defrost thermostat should be located on stub tube. Note that there is only 1 stub tube used with liquid header, and on most units it is the bottom circuit.

**Step 8—In Long-Line Applications, Install Liquid-Line Solenoid Valve (LSV)**

For refrigerant piping arrangements with equivalent lengths greater than 50 ft and/or when elevation difference between indoor and outdoor unit is greater than ± 20 ft, follow all requirements of the Long-Line Guideline section in the Application Guideline and Service Manual for Residential Split-System Air Conditioners and Heat Pumps Using Puron® Refrigerant.

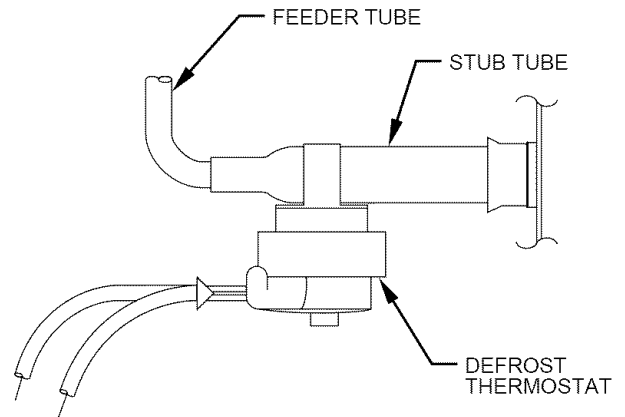

A97517

**Fig. 6—Defrost Thermostat Location**

If required by Long-Line Application Guideline, install LSV kit part No. KHALS0401LLS specifically designed for Puron® Heat Pump. LSV should be installed within 2 ft of the outdoor unit with flow arrow pointing toward outdoor unit, as close as possible to filter drier. Follow the Installation Instructions included with accessory kit.

**IMPORTANT:** Flow arrow must point toward outdoor unit.

**Step 9—Making Piping Connections**

**⚠ WARNING**

Relieve pressure and recover all refrigerant before system repair or final unit disposal to avoid personal injury or death. Use all service ports and open all flow-control devices, including solenoid valves.

**Table 1—Refrigerant Connections and Recommended Liquid Line and Vapor Tube Diameters (In.)**

UNIT SIZE	CONNECTION DIAMETER		TUBE DIAMETER		TUBE DIAMETER (ALTERNATE)
	Liquid	Vapor	Liquid	Vapor	Vapor
018, 024	3/8	5/8	3/8	5/8	3/4
030	3/8	3/4	3/8	3/4	5/8, 7/8
036	3/8	3/4	3/8	3/4	5/8, 7/8
042, 048	3/8	7/8	3/8	7/8	3/4
060	3/8	1-1/8	3/8	1-1/8	7/8

**NOTES:**

1. Tube diameters are for lengths up to 50 ft. For tubing lengths greater than 50 ft horizontal and/or 20 ft vertical differential, consult the Application Guideline and Service Manual — Residential Split-System Air Conditioners and Heat Pumps Using Puron® Refrigerant.
2. Refrigerant tubes and indoor coils must be evacuated to 500 microns to minimize contamination and moisture in the system.
3. If required by local codes, Pressur Guard™ kit is available. See Product Data Digest for part numbers.

**⚠ CAUTION**

Do not leave system open to atmosphere any longer than minimum required for installation. POE oil in compressor is extremely susceptible to moisture absorption. Always keep ends of tubing sealed during installation.

**⚠ CAUTION**

If ANY refrigerant tubing is buried, provide a 6 in. vertical rise at service valve. Refrigerant tubing lengths up to 36 in. may be buried. Do NOT bury tubing lengths over 36 in.

**⚠ CAUTION**

To prevent damage to unit or service valves observe the following:

- Use a brazing shield
- Wrap service valves with wet cloth or use a heat sink material.

Outdoor units may be connected to indoor section using accessory tubing package or field-supplied refrigerant grade tubing of correct size and condition. For tubing requirements beyond 50 ft, substantial capacity and performance losses can occur. Following the recommendations in the Application Guideline and Service Manual for Residential Split-System Air Conditioners and Heat Pumps using Puron® Refrigerant to minimize losses. Refer to Table 1 for field tubing diameters. Refer to Table 2 for accessory requirements.

Refrigerant tubes and indoor coil must be evacuated to 500 microns to minimize contamination and moisture in the system.

**OUTDOOR UNIT CONNECTED TO FACTORY-APPROVED INDOOR UNIT**

These outdoor units are carefully evaluated and listed with specific indoor coils for proper system performance.

**IMPORTANT:** Do not apply indoor coils which are not factory approved to these units.

**INSTALL ADAPTER TUBE**

1. Remove plastic retainer holding outdoor piston in liquid service valve.
2. Check outdoor piston size with matching number listed on unit rating plate.
3. Locate plastic bag taped to unit containing adapter tube.
4. Remove teflon washer from bag and install on open end of liquid service valve. (See Fig. 7.)
5. Remove adapter tube from bag and connect threaded nut to liquid service valve. Tighten nut finger tight and then with

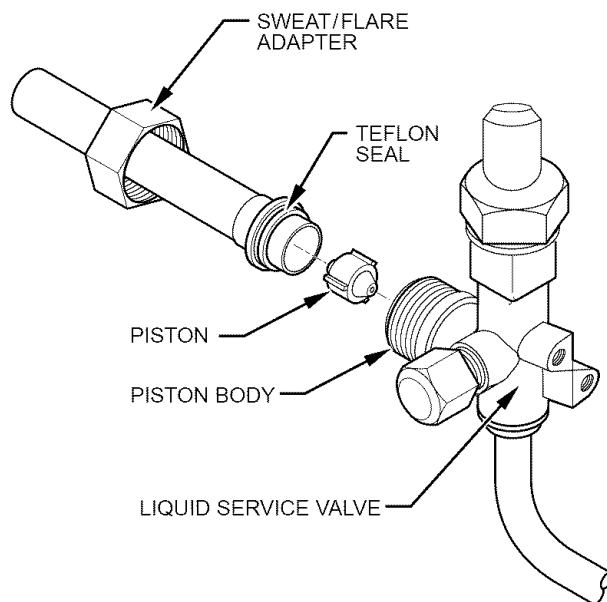

A01214

**Fig. 7—Liquid Service Valve with Sweat Adapter Tube**

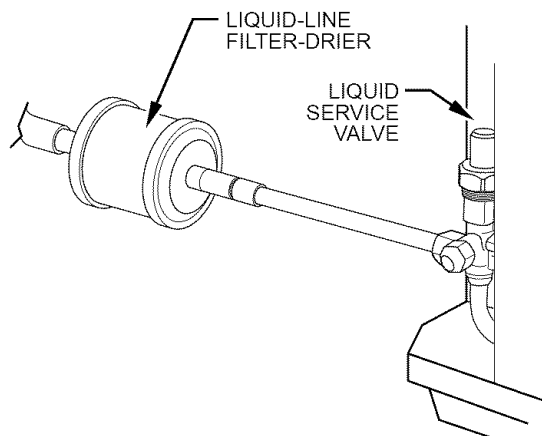

A01215

**Fig. 8—Filter Drier with Sweat Adapter Tube and Liquid Tube**

Table 2—Accessory Usage

ACCESSORY	REQUIRED FOR LOW-AMBIENT APPLICATIONS (BELOW 55°F)	REQUIRED FOR LONG-LINE APPLICATIONS* (OVER 50 FT)
Crankcase Heater	Yes	Yes
Evaporator Freeze Thermostat	Yes	No
Compressor Start Assist—Capacitor and Relay	Yes	Yes
Puron® Low-Ambient Pressure Switch	Yes	No
Wind Baffle	See Low-Ambient Instructions	No
Support Feet	Recommended	No
Hard Shutoff TXV	Yes†	Yes†
Liquid-Line Solenoid Valve for Heating	No	See Long-Line Application Guideline

\* For tubing line sets between 50 and 175 ft, or when vertical difference is greater than 20 ft, refer to Application Guideline and Service Manual — Residential Split-System Air Conditioners and Heat Pumps Using Puron®.

† Required for all applications.

wrench an additional 1/12 turn (15 ft-lb). DO NOT OVERTIGHTEN.

REFRIGERANT TUBING AND FILTER DRIER

**CAUTION**  
Installation of filter drier in liquid line is required to avoid performance loss due to plugged circuits or plugged expansion devices, and to avoid compressor failure.

Connect vapor tubing to fittings on outdoor unit vapor service valves. Connect liquid tube to filter drier. (See Table 1 and Fig. 8.) Use refrigerant grade tubing. Connect other end of filter drier to adapter tube on liquid service valve.

SWEAT CONNECTION

**CAUTION**  
To avoid valve damage while brazing, service valves must be wrapped in a heat-sink material such as a wet cloth.

Wrap service valves and filter drier with a wet cloth or heat-sinking material. Braze connections using either silver bearing or non-silver bearing brazing material. Do not use soft solder (materials which melt below 800°F.) Consult local code requirements.

LEAK CHECKING

Leak test all joints in indoor, outdoor, and refrigerant tubing.

EVACUATE REFRIGERANT TUBING AND INDOOR COIL

**CAUTION**  
To avoid compressor damage never use the system compressor as a vacuum pump.

Refrigerant tubes and indoor coil should be evacuated using the recommended deep vacuum method of 500 microns. The alternate triple evacuation method may be used if the procedure outlined below is followed.

**IMPORTANT:** Never open system under vacuum to atmosphere without first breaking it open with nitrogen.

Deep Vacuum Method

The deep vacuum method requires a vacuum pump capable of pulling a vacuum of 500 microns and a vacuum gage capable of accurately measuring this vacuum depth. The deep vacuum method is the most positive way of assuring a system is free of air and liquid water. (See Fig. 9.)

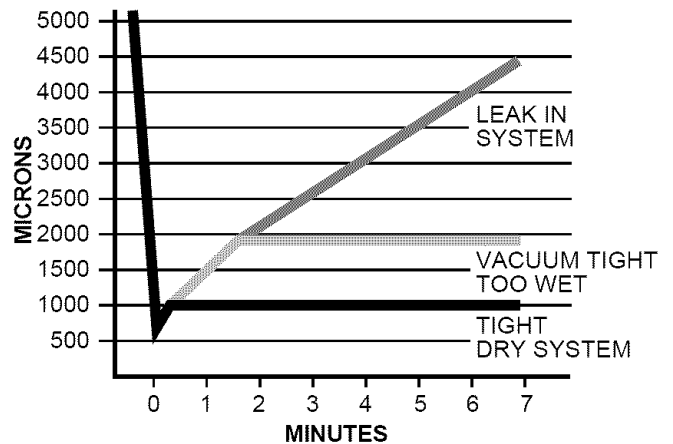

A95424

Fig. 9—Deep Vacuum Graph

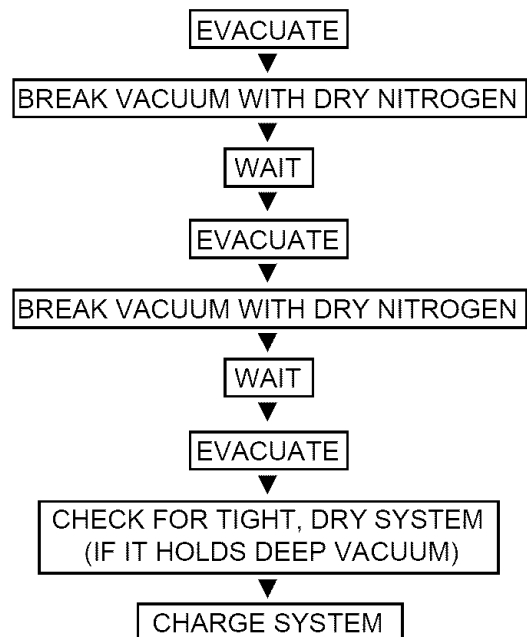

A95425

Fig. 10—Triple Evacuation Method

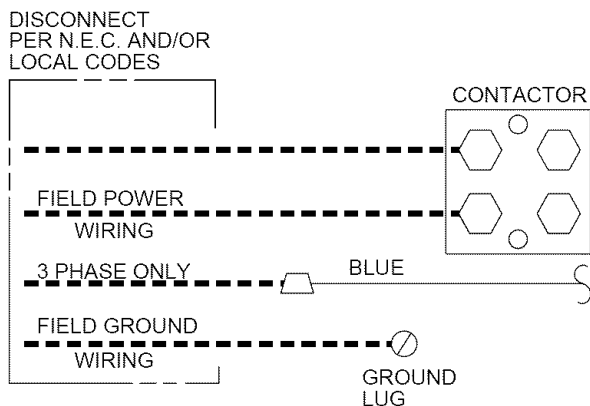

A94025

**Fig. 11—Line Power Connections**

### Triple Evacuation Method

The triple evacuation method should only be used when vacuum pump is only capable of pumping down to 28 in. of mercury vacuum and system does not contain any liquid water. Refer to Fig. 10 and proceed as follows:

1. Pump system down to 28 in. of mercury and allow pump to continue operating for an additional 15 minutes.
2. Close service valves and shut off vacuum pump.
3. Connect a nitrogen cylinder and regulator to system and open until system pressure is 2 psig.
4. Close service valve and allow system to stand for 1 hr. During this time, dry nitrogen will be able to diffuse throughout the system absorbing moisture.
5. Repeat this procedure as indicated in Fig. 10. System will then be free of any contaminants and water vapor.

### FINAL TUBING CHECK

**IMPORTANT:** Check to be certain factory tubing on both indoor and outdoor unit has not shifted during shipment. Ensure tubes are not rubbing against each other or any sheet metal. Pay close attention to feeder tubes, making sure wire ties on feeder tubes are secure and tight.

### Step 10—Make Electrical Connections

#### ⚠ WARNING

To avoid personal injury or death, do not supply power to unit with compressor terminal box cover removed.

Be sure field wiring complies with local and national fire, safety, and electrical codes, and voltage to system is within limits shown on unit rating plate. Contact local power company to correct improper voltage. See unit rating plate for recommended circuit protection device.

**NOTE:** Operation of unit on improper line voltage constitutes abuse and could affect unit reliability. See unit rating plate. Do not install unit in system where voltage or phase imbalance (3-phase) may fluctuate above or below permissible limits.

**NOTE:** Use copper wire only between disconnect switch and unit.

**NOTE:** Install branch circuit disconnect of adequate size per NEC to handle unit starting current. Locate disconnect within sight from and readily accessible from unit, per Section 440-14 of NEC.

### ROUTE GROUND AND POWER WIRES

Remove access panel to gain access to unit wiring. Extend wires from disconnect through power wiring hole provided and into unit control box.

#### ⚠ WARNING

The unit cabinet must have an uninterrupted or unbroken ground to minimize personal injury if an electrical fault should occur. The ground may consist of electrical wire or metal conduit when installed in accordance with existing electrical codes. Failure to follow this warning can result in an electric shock, fire, or death.

### CONNECT GROUND AND POWER WIRES

See Thermostat Installation Instructions for wiring specific unit combinations. Connect ground wire to ground connection in control box for safety. Connect power wiring to contactor as shown in Fig. 11.

### CONNECT CONTROL WIRING

Route 24v control wires through control wiring grommet and connect leads to control wiring. See Thermostat Installation Instructions for wiring specific unit combination. (See Fig. 12.)

Use No. 18 AWG color-coded, insulated (35°C minimum) wire. If thermostat is located more than 100 ft from unit, as measured along the control voltage wires, use No. 16 AWG color-coded wire to avoid excessive voltage drop.

All wiring must be NEC Class 1 and must be separated from incoming power leads.

Use furnace transformer, fan coil transformer, or accessory transformer for control power, 24v/40va minimum.

**NOTE:** Use of available 24v accessories may exceed the minimum 40va power requirement. Determine total transformer loading and increase the transformer capacity or split the load with an accessory transformer as required.

### FINAL WIRING CHECK

**IMPORTANT:** Check factory wiring and field wire connections to ensure terminations are secured properly. Check wire routing to ensure wires are not in contact with tubing, sheet metal, etc.

### Step 11—Compressor Crankcase Heater

When equipped with a crankcase heater, furnish power to heater a minimum of 24 hr before starting unit. To furnish power to heater only, set thermostat to OFF and close electrical disconnect to outdoor unit.

A crankcase heater is required in long-line applications (tubing greater than 50 ft. horizontal and/or elevation greater than 20 ft. between indoor and outdoor units). Refer to Application Guideline and Service Manual for Residential Split-System Air Conditioners and Heat Pumps Using Puron® Refrigerant.

### Step 12—Install Electrical Accessories

Refer to the individual instructions packaged with kits or accessories when installing.

### Step 13—Start-Up

#### ⚠ CAUTION

To prevent compressor damage or personal injury, observe the following:

- Do not overcharge system with refrigerant.
  - Do not operate unit in a vacuum or at negative pressure.
  - Do not disable low-pressure switch
- In scroll compressor applications:
- Dome temperatures may be hot

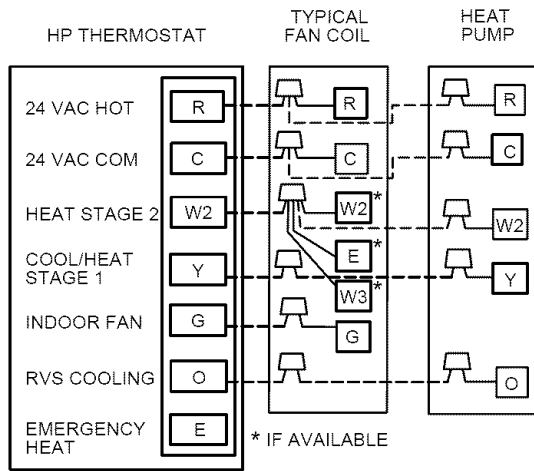

**Fig. 12—Generic Wiring Diagram**  
 (See Thermostat Installation Instructions  
 for wiring specific unit combinations)

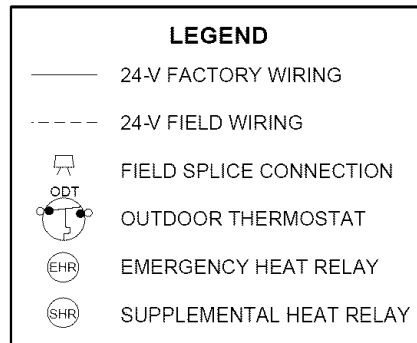

A97413

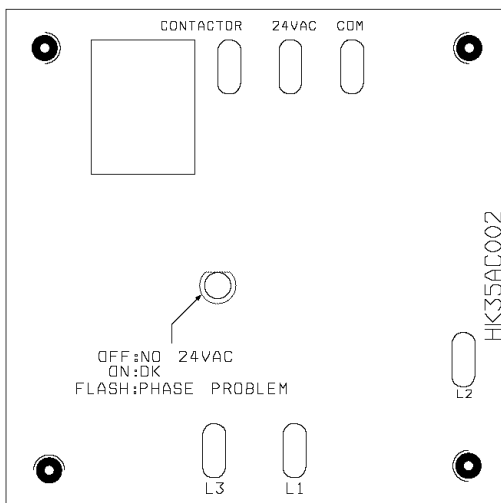

A00010

**Fig. 13—Phase Monitor Control**

**CAUTION**  
 To prevent personal injury wear safety glasses, protective clothing, and gloves when handling refrigerant.

**CAUTION**  
 Back seating service valves are not equipped with Schrader valves. Fully back seat (counter clockwise) valve stem before removing gage port cap.

**CAUTION**  
 Federal regulations require that you do not vent refrigerant into the atmosphere. Recover during system repair or final unit disposal.

Follow these steps to properly start up the system.

1. Fully back seat (open) liquid and vapor service valves.
2. Unit is shipped with valve stem(s) front seated (closed) and caps installed. replace stem caps after system is opened to refrigerant flow (back seated). Replace caps finger-tight and tighten with wrench an additional 1/12 turn. Use a backup wrench on valve body flats to prevent distortion of sheet metal.
3. Close electrical disconnects to energize system.
4. Set room thermostat at desired temperature. Be sure set point is below indoor ambient temperature.
5. Set room thermostat to HEAT or COOL and fan control to ON or AUTO mode, as desired. Operate unit for 15 minutes. Check system refrigerant charge.

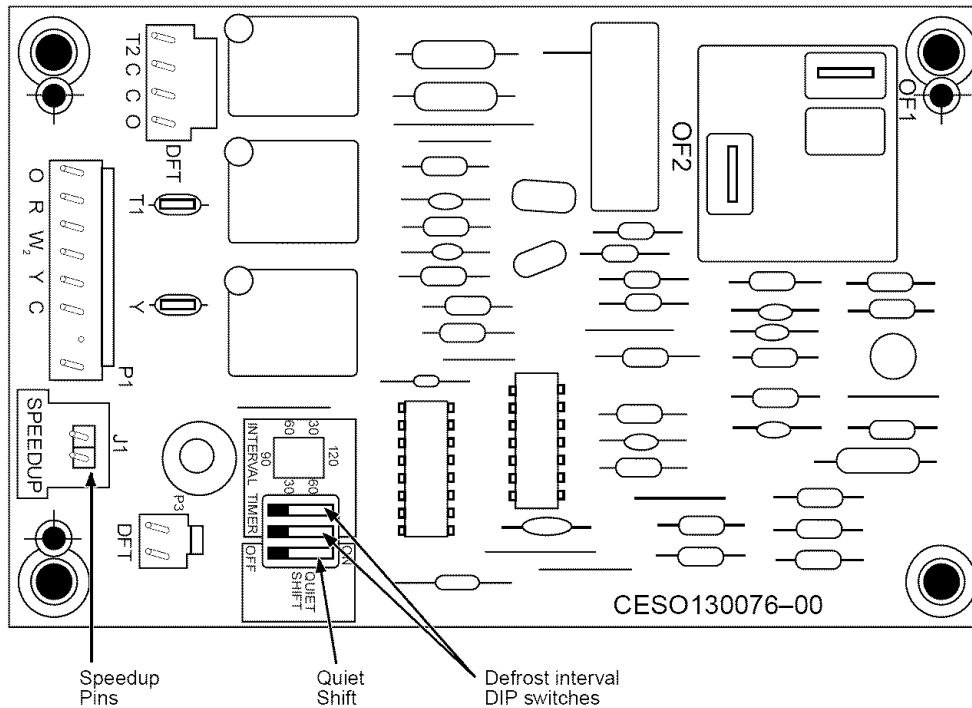

A99442

Fig. 14—Defrost Control

**CAUTION**

- 3-phase scroll compressors are rotation sensitive.
- A flashing LED on phase monitor indicates reverse rotation. (See Fig. 18 and Table 3.)
- This will not allow contactor to be energized.
- Disconnect power to unit and interchange 2 field wiring leads on unit contactor.

SEQUENCE OF OPERATION

**NOTE:** Defrost control board is equipped with a 5-minute lock-out timer which may be initiated upon an interruption of power.

With power supplied to indoor and outdoor units, transformer is energized.

Cooling

On a call for cooling, thermostat makes circuits R-O, R-Y, and R-G. Circuit R-O energizes reversing valve, switching it to cooling position. On three phase models with scroll compressors, the units are equipped with a phase monitor to detect if the incoming power is correctly phased for compressor operation. (See Fig. 18 and Table 3.) If the phasing is correct, circuit R-Y energizes contactor, starting outdoor fan motor and compressor circuit. R-G energizes indoor unit blower relay, starting indoor blower motor on high speed.

**NOTE:** If the phasing is incorrect, the contactor will not be energized. To correct the phasing interchange any two of the three power connections on the field side.

When thermostat is satisfied, contacts open, de-energizing the contactor and blower relay. Compressor and motors should stop.

**NOTE:** If indoor unit is equipped with a time-delay relay circuit, the blower runs an additional 90 sec to increase system efficiency.

Heating

On a call for heating, thermostat makes circuits R-Y and R-G. If phasing is correct, circuit R-Y energizes contactor, starting outdoor fan motor and compressor. Circuit R-G energizes indoor blower relay, starting blower motor on high speed.

Should temperature continue to fall, R-W2 is made through sec-stage room thermostat bulb. Circuit R-W2 energizes a sequencer, bringing on first bank of supplemental electric heat and providing electrical potential to sec heater sequencer (if used). If outdoor temperature falls below setting of outdoor thermostat (field-installed option), contacts close to complete circuit and bring on sec bank of supplemental electric heat.

When thermostat is satisfied, its contactors open, de-energizing contactor and sequencer. All heaters and motors should stop.

TABLE 3—PHASE MONITOR LED INDICATORS

LED	STATUS
OFF	No call for compressor operation
FLASHING	Reversed phase
ON	Normal

Quiet Shift

Quiet Shift is a field-selectable defrost mode, which will eliminate occasional noise that could be heard at the start of the defrost cycle and restarting of heating cycle. It is selected by placing DIP switch 3 (on defrost board) in ON position.

When Quiet Shift switch is placed in ON position, and a defrost is initiated, the following sequence of operation will occur. Reversing valve will energize, compressor will turn off for 30 sec, then turn back on to complete defrost. At the start of heating cycle after conclusion of defrost mode, reversing valve will de-energize, the compressor will turn off for another 30 sec, and the fan will turn off for 40 sec, before starting in the heating mode.

Defrost

The defrost control is a time/temperature control which includes a field-selectable time period (DIP switch 1 and 2 on the board) between defrost cycles of 30, 60, 90, or 120 minutes (factory set at 90 minutes).

To initiate a forced defrost, two options are available depending on the status of the defrost thermostat.



If defrost thermostat is closed, speedup pins (J1) must be shorted by placing a flat head screwdriver in between for 5 sec and releasing, to observe a complete defrost cycle. When the Quiet Shift switch is selected, compressor will be turned off for two 30 sec intervals during this complete defrost cycle as explained previously. When Quiet Shift switch is in factory default OFF position, a normal and complete defrost cycle will be observed.

If defrost thermostat is in open position, and speedup pins are shorted (with a flat head screwdriver) for 5 sec and released, a short defrost cycle will be observed (actual length is dependent upon the selected Quiet Shift position). When Quiet Shift switch is in ON position, the length of defrost is 1 minute (30 sec compressor off period followed by 30 sec of defrost with compressor operation). On return to heating operation, compressor will again turn off for an additional 30 sec and the fan for 40 sec. When the Quiet Shift is in OFF position, only a brief 30 sec cycle will be observed.

If it is desirable to observe a complete defrost in warmer weather, the thermostat must be closed as follows:

1. Turn off power to outdoor unit.
2. Disconnect outdoor fan motor lead from OF2 on control board (See Fig. 19.) Tape to prevent grounding.
3. Restart unit in heating mode, allowing frost to accumulate on outdoor coil.
4. After a few minutes in heating mode, liquid line temperature should drop below closing point of defrost thermostat (approximately 30°F).

**NOTE:** Unit will remain in defrost until defrost thermostat reopens at approximately 80°F coil temperature at liquid line or remainder of defrost cycle time.

5. Turn off power to outdoor and reconnect fan motor lead to OF2 on control board after above forced defrost cycle.

#### Step 14—Check Charge

##### UNIT CHARGE

Factory charge is shown on unit rating plate. To check charge in cooling mode, refer to Cooling Only Procedure. To check charge in heating mode, refer to Heating Check Chart Procedure.

##### COOLING ONLY PROCEDURE

**NOTE:** If superheat or subcooling charging conditions are not favorable, charge must be weighed in accordance with unit rating plate  $\pm 0.6$  oz/ft of 3/8-in. liquid line above or below 15 ft respectively.

##### EXAMPLE:

To calculate additional charge required for a 25-ft line set:

$$25 \text{ ft} - 15 \text{ ft} = 10 \text{ ft} \times 0.6 \text{ oz/ft} = 6 \text{ oz of additional charge}$$

Units installed with cooling mode TXV require charging with the subcooling method.

1. Operate unit a minimum of 10 minutes before checking charge.
2. Measure liquid service valve pressure by attaching an accurate gage to service port.
3. Measure liquid line temperature by attaching an accurate thermistor type or electronic thermometer to liquid near outdoor coil.
4. Refer to Heat Pump Charging Instructions label on outdoor unit.
5. Refer to Table 4. Find the point where required subcooling temperature intersects measured liquid service valve pressure.
6. To obtain required subcooling temperature at a specific liquid line pressure, add refrigerant if liquid line temperature is higher than indicated or reclaim refrigerant if temperature is lower. Allow a tolerance of  $\pm 3^\circ\text{F}$ .

#### HEATING CHECK CHART PROCEDURE

To check system operation during heating cycle, refer to the HEAT Pump Charging Instructions label on outdoor unit. This chart indicates whether a correct relationship exists between system operating pressure and air temperature entering indoor and outdoor units. If pressure and temperature do not match on chart, system refrigerant charge may not be correct. Do not use chart to adjust refrigerant charge.

**NOTE:** In heating mode, check refrigerant charge only when pressures are stable. If in doubt, remove charge and weigh in correct refrigerant charge.

**NOTE:** When charging is necessary during heating season, charge must be weighed in accordance with unit rating plate  $\pm 0.6$  oz/ft of 3/8-in. liquid line above or below 15 ft respectively.

##### EXAMPLE:

To calculate additional charge required for a 25-ft line set:

$$25 \text{ ft} - 15 \text{ ft} = 10 \text{ ft} \times 0.6 \text{ oz/ft} = 6 \text{ oz of additional charge}$$

#### Step 15—Final Checks

**IMPORTANT:** Before leaving job, be sure to do the following:

1. Securely fasten all panels and covers.
2. Tighten service valve stem caps to 1/12-turn past finger tight.
3. Leave User's Manual with owner. Explain system operation and periodic maintenance requirements outlined in manual.
4. Fill out Dealer Installation Checklist and place in customer file.

#### CARE AND MAINTENANCE

For continuing high performance and to minimize possible equipment failure, periodic maintenance must be performed on this equipment.

Frequency of maintenance may vary depending upon geographic areas, such as coastal applications.

**Table 4—Required Liquid-Line Temperature (°F)**

LIQUID PRESSURE AT SERVICE VALVE	REQUIRED SUBCOOLING TEMPERATURE (°F)				LIQUID PRESSURE AT SERVICE VALVE	REQUIRED SUBCOOLING TEMPERATURE (°F)			
	5	10	15	20		5	10	15	20
<b>174</b>	56	51	46	41	<b>398</b>	112	107	102	97
<b>181</b>	58	53	48	43	<b>405</b>	113	108	103	98
<b>188</b>	61	56	51	46	<b>412</b>	114	109	104	99
<b>195</b>	63	58	53	48	<b>419</b>	115	110	105	100
<b>202</b>	65	60	55	50	<b>426</b>	117	112	107	102
<b>209</b>	67	62	57	52	<b>433</b>	118	113	108	103
<b>216</b>	69	64	59	54	<b>440</b>	119	114	109	104
<b>223</b>	71	66	61	56	<b>447</b>	120	115	110	105
<b>230</b>	73	68	63	58	<b>454</b>	122	117	112	107
<b>237</b>	75	70	65	60	<b>461</b>	123	118	113	108
<b>244</b>	77	72	67	62	<b>468</b>	124	119	114	109
<b>251</b>	79	74	69	64	<b>475</b>	125	120	115	110
<b>258</b>	81	76	71	66	<b>482</b>	126	121	116	111
<b>265</b>	82	77	72	67	<b>489</b>	127	122	117	112
<b>272</b>	84	79	74	69	<b>496</b>	129	124	119	114
<b>279</b>	86	81	76	71	<b>503</b>	130	125	120	115
<b>286</b>	88	83	78	73	<b>510</b>	131	126	121	116
<b>293</b>	89	84	79	74	<b>517</b>	132	127	122	117
<b>300</b>	91	86	81	76	<b>524</b>	133	128	123	118
<b>307</b>	93	88	83	78	<b>531</b>	134	129	124	119
<b>314</b>	94	89	84	79	<b>538</b>	135	130	125	120
<b>321</b>	96	91	86	81	<b>545</b>	136	131	126	121
<b>328</b>	97	92	87	82	<b>552</b>	137	132	127	122
<b>335</b>	99	94	89	84	<b>559</b>	138	133	128	123
<b>342</b>	100	95	90	85	<b>566</b>	139	134	129	124
<b>349</b>	102	97	92	87	<b>573</b>	140	135	130	125
<b>356</b>	103	98	93	88	<b>580</b>	141	136	131	126
<b>363</b>	105	100	95	90	<b>587</b>	142	137	132	127
<b>370</b>	106	101	96	91	<b>594</b>	143	138	133	128
<b>377</b>	107	102	97	92	<b>601</b>	144	139	134	129
<b>384</b>	109	104	99	94	<b>608</b>	145	140	135	130
<b>391</b>	110	105	100	95	—	—	—	—	—

# PURON® (R-410A) QUICK REFERENCE GUIDE

- Puron® refrigerant operates at 50-70 percent higher pressures than R-22. Be sure that servicing equipment and replacement components are designed to operate with Puron®.
- Puron® refrigerant cylinders are rose colored.
- Recovery cylinder service pressure rating must be 400 psig. DOT 4BA400 or DOT BW400.
- Puron® systems should be charged with liquid refrigerant. Use a commercial type metering device in the manifold hose when charging into suction line with compressor operating.
- Manifold sets should be at least 700 psig high side and 180 psig low side with 550 psig low-side retard.
- Use hoses with 700 psig service pressure rating.
- Leak detectors should be designed to detect HFC refrigerant.
- Puron®, as with other HFCs, is only compatible with POE oils.
- Vacuum pumps will not remove moisture from oil.
- Do not leave Puron® suction line filter driers in line longer than 72 hrs.
- Do not use liquid-line filter driers with rated working pressures less than 600 psig.
- Do not install a suction-line filter drier in liquid line.
- POE oils absorb moisture rapidly. Do not expose oil to atmosphere.
- POE oils may cause damage to certain plastics and roofing materials.
- Wrap all filter driers and service valves with wet cloth when brazing.
- A factory-approved liquid-line filter drier is required on every unit.
- Do not use an R-22 TXV.
- If indoor unit is equipped with an R-22 TXV, it must be changed to an Puron® TXV.
- All Puron® Heat Pumps must have indoor Puron® TXV.
- Never open system to atmosphere while it is under a vacuum.
- When system must be opened for service, recover refrigerant, break vacuum with dry nitrogen prior to opening to atmosphere. Evacuate to 500 microns prior to recharging.
- Always replace filter drier after opening system for service.
- Do not vent Puron® into the atmosphere.
- Do not use capillary tube coils.
- Observe all **warnings**, **cautions**, and **bold** text.

**Manufacturer reserves the right to discontinue, or change at any time, specifications or designs without notice and without incurring obligations.**