

Visit [www.carrier.com](http://www.carrier.com)

## Installation and Start-Up Instructions

**NOTE:** Read the entire instruction manual before starting the installation.

This symbol → indicates a change since the last issue.

### SAFETY CONSIDERATIONS

Improper installation, adjustment, alteration, service, maintenance, or use can cause explosion, fire, electrical shock, or other conditions which may cause death, personal injury, or property damage. Consult a qualified installer, service agency, or your distributor or branch for information or assistance. The qualified installer or agency must use factory-authorized kits or accessories when modifying this product. Refer to the individual instructions packaged with the kits or accessories when installing.

Follow all safety codes. Wear safety glasses, protective clothing, and work gloves. Use quenching cloth for brazing operations. Have fire extinguisher available. Read these instructions thoroughly and follow all warnings or cautions included in literature and attached to the unit. Consult local building codes and National Electrical Code (NEC) for special requirements.

Recognize safety information. This is the safety-alert symbol . When you see this symbol on the unit and in instructions or manuals, be alert to the potential for personal injury.

Understand the signal words DANGER, WARNING, and CAUTION. These words are used with the safety-alert symbol. DANGER identifies the most serious hazards which **will** result in severe personal injury or death. WARNING signifies hazards which **could** result in personal injury or death. CAUTION is used to identify unsafe practices which **would** result in minor personal injury or product and property damage. NOTE is used to highlight suggestions which **will** result in enhanced installation, reliability, or operation.

### WARNING

Before installing, modifying, or servicing system, main electrical disconnect switch must be in the OFF position. There may be more than 1 disconnect switch. Lock out and tag switch with a suitable warning label. Electrical shock can cause personal injury or death.

### INSTALLATION RECOMMENDATIONS

**NOTE:** In some cases noise in the living area has been traced to gas pulsations from improper installation of equipment.

1. Locate unit away from windows, patios, decks, and so forth where unit operation sounds may disturb customer.
2. Ensure that vapor- and liquid-tube diameters are appropriate to capacity of unit.
3. Run refrigerant tubes as directly as possible by avoiding unnecessary turns and bends.

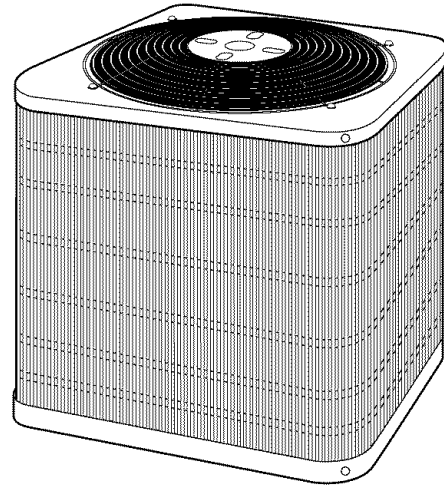

A98525

**Fig. 1—Model 38BYG**

4. Leave some slack between structure and unit to absorb vibration.
5. When passing refrigerant tubes through the wall, seal opening with RTV or other pliable silicon based caulk. (See Fig. 2.)
6. Avoid direct tubing contact with water pipes, duct work, floor joists, wall studs, floors, and walls.
7. Do not suspend refrigerant tubing from joists and studs with a rigid wire or strap that comes in direct contact with tubing. (See Fig. 2.)
8. Ensure that tubing insulation is pliable and completely surrounds vapor tube.
9. When necessary, use hanger straps which are 1 in. wide and conform to shape of tubing insulation. (See Fig. 2.)
10. Isolate hanger straps from insulation by using metal sleeves bent to conform to shape of insulation.

When outdoor unit is connected to factory-approved indoor unit, outdoor unit contains system refrigerant charge for operation with indoor unit of the same size when connected by 15 ft of field-supplied or factory-accessory tubing. For proper unit operation, check refrigerant charge using charging information located on control box cover.

**IMPORTANT:** Maximum liquid line size is 3/8-in. O.D. for all residential applications including long line.

**IMPORTANT:** Always install a liquid line filter drier on any system using existing field service line sets and or existing indoor coil or fan coil units. Always use a filter drier on burnout unit replacements.

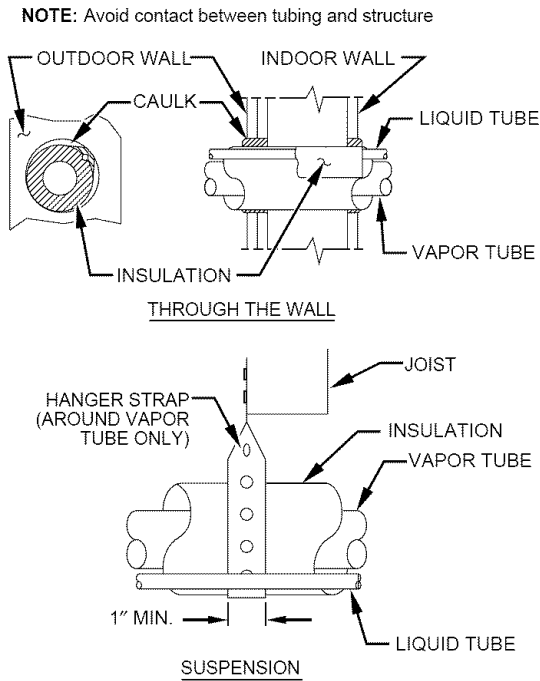

A94028

**Fig. 2—Connecting Tubing Installation**

**INSTALLATION**

**Step 1—Check Equipment and Job Site**

**UNPACK UNIT**

Move to final location. Remove carton, taking care not to damage unit.

**INSPECT EQUIPMENT**

File claim with shipping company prior to installation if shipment is damaged or incomplete. Locate unit rating plate on unit service panel. It contains information needed to properly install unit. Check rating plate to be sure unit matches job specifications.

**Step 2—Install On A Solid, Level Mounting Pad**

If conditions or local codes require the unit be attached to pad, tiedown bolts should be used and fastened through knockouts provided in unit base pan. Refer to unit mounting pattern in Fig. 3 to determine base pan size and knockout hole location.

On rooftop applications, mount on level platform or frame. Place unit above a load bearing wall and isolate unit and tubing set from structure. Arrange supporting members to adequately support unit and minimize transmission of vibration to building. Consult local codes governing rooftop applications.

Roof mounted units exposed to winds above 5 mph may require wind baffles to achieve adequate defrost. Consult Low Ambient Guideline for wind baffle construction.

**NOTE:** Unit must be level to within  $\pm 2^\circ$  ( $\pm 3/8$  in./ft) per compressor manufacturer specifications.

**Step 3—Clearance Requirements**

When installing, allow sufficient space for airflow clearance, wiring, refrigerant piping, and service. Allow 30-in. clearance to service end of unit and 48 in. above unit. For proper airflow, a 6-in. clearance on 1 side of unit and 12 in. on all remaining sides must be maintained. Maintain a distance of 24 in. between units. Position so water, snow, or ice from roof or eaves cannot fall directly on unit.

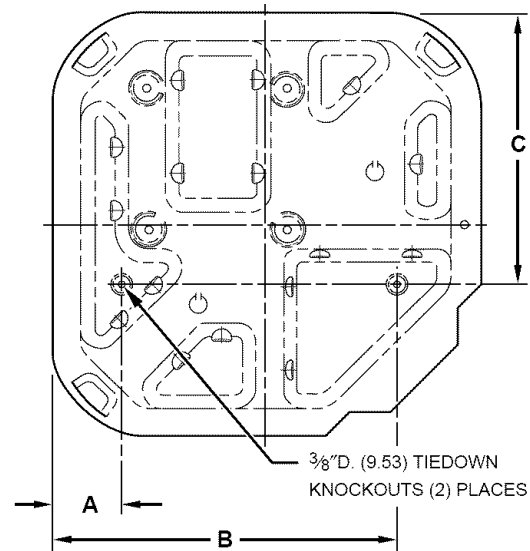

A94199

**Dimensions (In.)**

UNIT SIZE	MINIMUM MOUNTING-PAD DIMENSIONS	TIEDOWN KNOCKOUT LOCATIONS		
		A	B	C
018-024	22-1/2 X 22-1/2	3-11/16	18-1/8	14-3/8
030-060	30 X 30	6-1/2	23-1/2	20

**Fig. 3—Mounting Unit to Pad**

On rooftop applications, locate unit at least 6 in. above roof surface.

**Step 4—Operating Ambient**

The minimum outdoor operating ambient in cooling mode is 55°F, and the maximum outdoor operating ambient in cooling mode is 125°F. The maximum outdoor operating ambient in heating mode is 66°F.

**Step 5—Elevate Unit**

**⚠ CAUTION**

Accumulation of water and ice in base pan may cause equipment damage.

In areas where prolonged freezing temperatures are encountered, elevate unit per local climate and code requirements to provide clearance above estimated snowfall level and ensure adequate drainage of unit.

**Step 6—Remove Indoor AccuRater® Piston and Install TXV**

**⚠ CAUTION**

For proper unit operation and reliability, units must be installed with field supplied hard shutoff TXV. Do not install with evaporator coils having capillary tube metering devices or pistons.

For TXV kit part number and charging instructions, refer to TXV label in outdoor unit. If indoor unit (fan coil) comes factory equipped with a bi-flow hard shutoff TXV, no TXV change is required.

If TXV installation is required, remove existing AccuRater® from indoor coil. Refer to Figs. 4 and 5 and install TXV kit as follows:

1. Install suction tube adapter.
2. Install liquid flare-to-sweat adapter.
3. Connect external equalizer tube to fitting on suction tube adapter.
4. Position sensing bulb on horizontal portion of suction tube adapter. Secure using supplied hardware.
5. Insulate bulb after installation. (See Fig. 5.)
6. Leak check all connections.

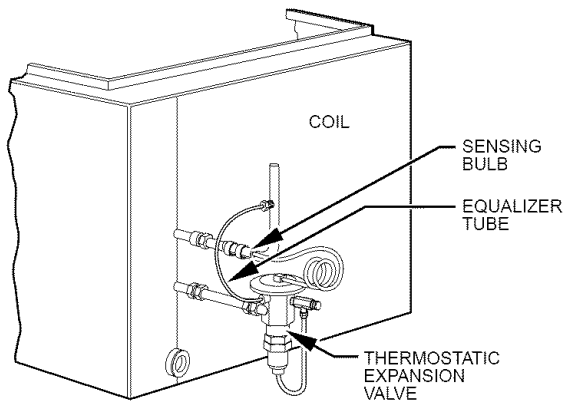

A88382

**Fig. 4—Typical TXV Installation**

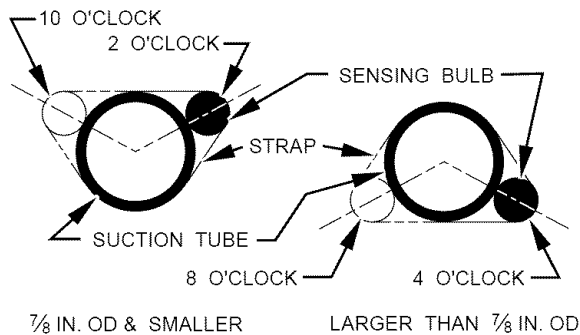

A81032

**Fig. 5—Positioning of Sensing Bulb**

**Step 7—Check Outdoor AccuRater® Piston**

Check outdoor unit piston. Remove retainer on liquid service valve and check piston size with matching number listed on outdoor unit rating plate.

**Step 8—Check Defrost Thermostat**

Check defrost thermostat to ensure it is properly located and securely attached. There is a liquid header with a brass distributor and feeder tube going into outdoor coil. At the end of 1 of the

feeder tubes, there is a 3/8-in. O.D. stub tube approximately 2 in. long. (See Fig. 6.) The defrost thermostat should be located on stub tube. Note that there is only 1 stub tube used with liquid header, and on most units it is the bottom circuit.

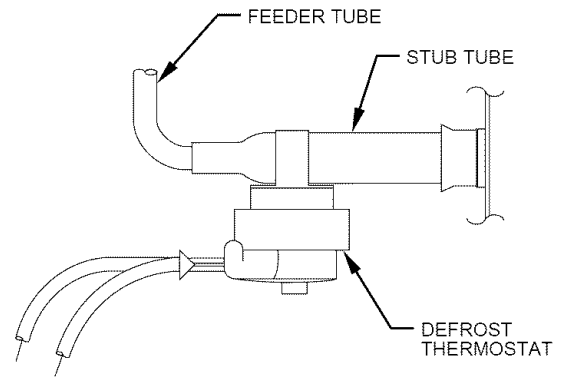

A97517

**Fig. 6—Defrost Thermostat Location**

**Step 9—Make Piping Connections**

**⚠ WARNING**

Relieve pressure and recover all refrigerant before system repair or final unit disposal to avoid personal injury or death. Use all service ports and open all flow control devices, including solenoid valves.

**⚠ CAUTION**

If ANY refrigerant tubing is buried, provide a 6 in. vertical rise at service valve. Refrigerant tubing lengths up to 36 in. may be buried without further special consideration. For lengths longer than 36 in., refer to Application Guideline and Service Manual — Residential Split System Air Conditioners and Heat Pumps.

**⚠ CAUTION**

To prevent damage to unit or service valves observe the following:

- Use a brazing shield.
- Wrap service valves with wet cloth or use a heat-sink material.

Outdoor units may be connected to indoor section using accessory-tubing package or field-supplied refrigerant grade tubing of correct size and condition. For tubing requirements beyond 50 ft, substantial capacity and performance losses can occur. Following the recommendations in the Residential Split System Long-Line Application Guideline will reduce these losses. Refer to Table 1 for field tubing equivalent line length. Refer to Table 2 for accessory requirements.

For buried line applications greater than 36 in., refer to Table 2 and Residential Split System Buried Line Application Guideline. Buried line applications may not exceed 100 ft.

If refrigerant tubes or indoor coil are exposed to atmosphere, they must be evacuated to 500 microns to eliminate contamination and moisture in the system.

**Table 1—Refrigerant Connections And Recommended Liquid- And Vapor-Tube Diameters (In.)**

UNIT SIZE	LIQUID		VAPOR		VAPOR (LONG LINE)	
	Connection Diameter	Tube Diameter	Connection Diameter	Tube Diameter	Connection Diameter	Tube Diameter
018	3/8	3/8	5/8	5/8	5/8	3/4
024	3/8	3/8	3/4	3/4	3/4	3/4
030, 036	3/8	3/8	3/4	3/4	3/4	7/8
042	3/8	3/8	7/8	7/8	7/8	1-1/8
048, 060	3/8	3/8	7/8	1-1/8	7/8	1-1/8

NOTES:  
 1. Tube diameters are for lengths up to 50 ft. For tubing lengths greater than 50 ft horizontal, or greater than 20 ft vertical differential, consult the Application Guideline and Service Manual — Air Conditioners and Heat Pumps.  
 2. Do not apply capillary tube indoor coils to these units.

**OUTDOOR UNIT CONNECTED TO FACTORY APPROVED INDOOR UNIT**

Outdoor unit contains correct system refrigerant charge for operation with indoor unit of same size when connected by 15 ft of field-supplied or factory accessory tubing. Check refrigerant charge for maximum efficiency.

**REFRIGERANT TUBING**

Connect tubing to fittings on outdoor unit vapor- and liquid-service valves. (See Table 1.) Use refrigerant grade tubing.

**SWEAT CONNECTION**

**CAUTION**  
 To avoid valve damage while brazing, service valves must be wrapped in a heat sink material such as a wet cloth.

Remove plastic retainer holding outdoor piston in liquid service valve and connect sweat/flare adapter provided to valve. (See Fig. 7.) Connect refrigerant tubing to fittings on outdoor unit vapor- and liquid-service valves. Service valves are closed from factory and ready for brazing. After wrapping service valve with a wet cloth, tubing set can be brazed to service valve using either silver bearing or non-silver bearing brazing material. Consult local code requirements. Refrigerant tubing and indoor coil are now ready for leak testing. This check should include all field and factory joints.

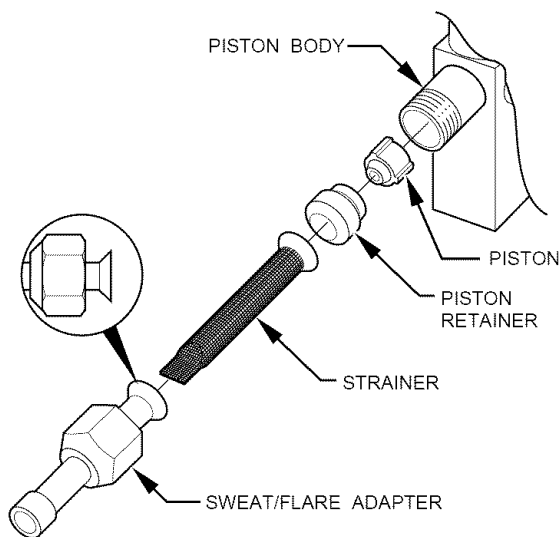

**Fig. 7—Liquid-Service Valve**

**IMPORTANT:** Check to be certain factory tubing on both indoor and outdoor unit has not shifted during shipment. Ensure tubes are not rubbing against each other or any sheet metal. Pay close

attention to feeder tubes, making sure wire ties on feeder tubes are secure and tight.

**Step 10—Make Electrical Connections**

**WARNING**  
 To avoid personal injury or death, do not supply power to unit with compressor terminal box cover removed.

Be sure field wiring complies with local and national fire, safety, and electrical codes, and voltage to system is within limits shown on unit rating plate. Contact local power company for correction of improper voltage. See unit rating plate for recommended circuit-protection device.

**NOTE:** Operation of unit on improper line voltage constitutes abuse and could affect unit reliability. See unit rating plate. Do not install unit in system where voltage may fluctuate above or below permissible limits.

**NOTE:** Use copper wire only between disconnect switch and unit.

**NOTE:** Install branch circuit disconnect of adequate size per NEC to handle unit starting current. Locate disconnect within sight from and readily accessible from unit, per Section 440-14 of NEC.

**ROUTE GROUND AND POWER WIRES**

Remove access panel to gain access to unit wiring. Extend wires from disconnect through power wiring hole provided and into unit control box.

**WARNING**  
 The unit cabinet must have an uninterrupted or unbroken ground to minimize personal injury if an electrical fault should occur. The ground may consist of electrical wire or metal conduit when installed in accordance with existing electrical codes. Failure to follow this warning can result in an electric shock, fire, or death.

**CONNECT GROUND AND POWER WIRES**

Connect ground wire to ground connection in control box for safety. Connect power wiring to contactor as shown in Fig. 8.

**CONNECT CONTROL WIRING**

Route 24v control wires through control wiring grommet and connect leads to control wiring. See Thermostat Installation Instructions for wiring specific unit combinations. (See Fig. 9.)

Use No. 18 AWG color coded, insulated (35°C minimum) wire. If thermostat is located more than 100 ft from unit, as measured along the control voltage wires, use No. 16 AWG color coded wire to avoid excessive voltage drop.

All wiring must be NEC Class 1 and must be separated from incoming power leads.

Table 2—Accessory Usage

ACCESSORY	REQUIRED FOR LOW-AMBIENT APPLICATIONS (BELOW 55°F)	REQUIRED FOR LONG-LINE APPLICATIONS* (OVER 50 FT)	REQUIRED FOR BURIED LINE APPLICATIONS† (OVER 3 FT)
Crankcase Heater	Yes	Yes	Yes
Evaporator Freeze Thermostat	Yes	No	No
Accumulator	No	No	Yes
Compressor Start-Assist Capacitor and Relay	Yes	Yes	Yes
MotorMaster® Control, or Low-Ambient Pressure Switch	Yes	No	No
Wind Baffle	See low-ambient Instructions	No	No
Unit Risers	Recommended	No	No
Liquid-Line Solenoid Valve or Hard-Shutoff TXV	No	See Long-Line Application Guideline	Yes
Ball-Bearing Fan Motor	Yes‡	No	No

\* For tubing line sets between 50 and 175 ft, refer to Application Guideline and Service Manual — Air Conditioners and Heat Pumps.

† For buried line applications, refer to Application Guideline and Service Manual — Air Conditioners and Heat Pumps.

‡ Required for low-ambient controller (full-modulation feature) and MotorMaster® Control only.

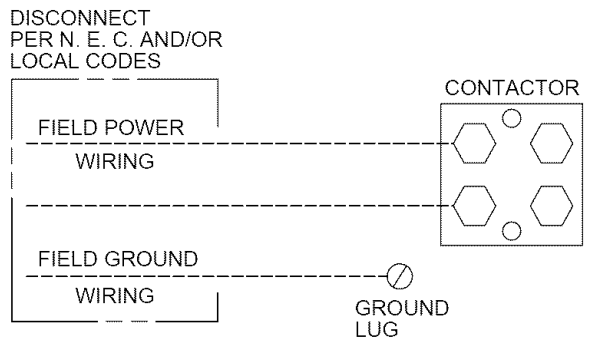

A91056

Fig. 8—Line Power Connections

Use furnace transformer, fan coil transformer, or accessory transformer for control power, 24v/40va minimum.

**NOTE:** Use of available 24v accessories may exceed the minimum 40va power requirement. Determine total transformer loading and increase the transformer capacity or split the load with an accessory transformer as required.

**IMPORTANT:** Check factory wiring and wire connections to ensure terminations are secured properly. Check wire routing to ensure wires are not in contact with tubing, sheet metal, and so forth.

### Step 11—Compressor Crankcase Heater

When equipped with a crankcase heater, furnish power to heater a minimum of 24 hr before starting unit. To furnish power to heater only, set thermostat to OFF and close electrical disconnect to outdoor unit. A crankcase heater is required if refrigerant tubing is longer than 50 ft.

### Step 12—Install Electrical Accessories

Refer to the individual instructions packaged with kits or accessories when installing.

### Step 13—Start-Up

#### ⚠ CAUTION

To prevent compressor damage or personal injury, observe the following:

- Do not overcharge system with refrigerant.
- Do not operate unit in a vacuum or at negative pressure.
- Do not disable low-pressure switch.

In scroll compressor applications:

- Dome temperatures may be hot.

#### ⚠ CAUTION

To prevent personal injury wear safety glasses, protective clothing, and gloves when handling refrigerant and observe the following:

- Back-seating service valves are not equipped with Schrader valves. Fully back seat (counterclockwise) valve stem before removing gage-port cap.
- Front-seating service valves are equipped with Schrader valves.

#### ⚠ CAUTION

Federal Regulations require that you do not vent refrigerant to atmosphere. Recover during system repair or final unit disposal.

Follow these steps to properly pumpdown a system and avoid negative suction pressure.

1. Fully back seat (open) liquid- and vapor-tube service valves.
2. Unit is shipped with valve stem(s) front seated (closed) and caps installed. Replace stem caps after system is opened to refrigerant flow. Replace caps finger-tight and tighten with wrench an additional 1/12 turn.
3. Close electrical disconnects to energize system.

- Set room thermostat to desired temperature. Be sure set point is below indoor-ambient temperature.
- Set room thermostat to HEAT or COOL and fan control to ON or AUTO mode, as desired. Operate unit for 15 minutes. Check system-refrigerant charge.

#### SEQUENCE OF OPERATION

**NOTE:** Defrost-control board may be equipped with 5-minute lockout timer that may be initiated upon any interruption of power.

With power supplied to indoor and outdoor units, transformer is energized.

#### COOLING

On a call for cooling, thermostat makes circuits R-O, R-Y, and R-G. Circuit R-O energizes reversing valve, switching it to cooling position. Circuit R-Y energizes contactor, starting outdoor-fan motor and compressor circuit. R-G energizes indoor unit-blower relay, starting indoor-blower motor on high speed.

When thermostat is satisfied, its contacts open, de-energizing the contactor and blower relay. Compressor and motors should stop.

**NOTE:** If indoor unit is equipped with a time-delay relay circuit, the blower runs an additional 90 sec to increase system efficiency.

outdoor temperature falls below setting of outdoor thermostat (field-installed option), contacts close to complete circuit and bring on second bank of supplemental electric heat.

When thermostat is satisfied, its contacts open, de-energizing contactor and relay. All heaters and motors should stop.

#### DEFROST

The defrost control is a time/temperature control which includes a field-selectable (quick-connects located at board edge) time period between defrost cycles (30, 60, or 90 minutes), factory set at 90 minutes.

The electronic timer and defrost cycle start only when contactor is energized and defrost thermostat is closed.

Defrost mode is identical to cooling mode except that outdoor-fan motor stops and second-stage heat is turned on to continue warming conditioned space.

To initiate defrost, the defrost thermostat must be closed. This can be accomplished as follows:

- Turn off power to outdoor unit.
- Disconnect outdoor-fan motor lead from OF2 on control board. (See Fig. 10.) Tape lead to prevent grounding.

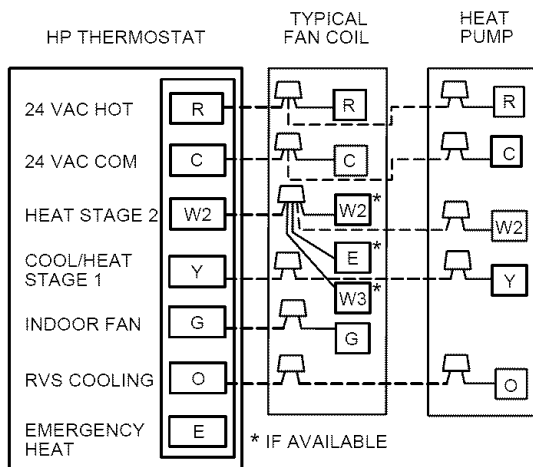

**Fig. 9—Generic Wiring Diagram**  
(See Thermostat Installation Instructions for wiring specific unit combinations.)

A02325

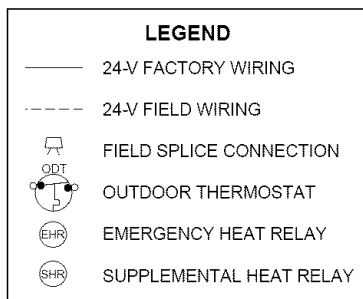

A97413

#### HEATING

On a call for heating, thermostat makes circuits R-Y and R-G. Circuit R-Y energizes contactor, starting outdoor-fan motor and compressor. Circuit R-G energizes indoor-blower relay, starting blower motor on high speed.

Should temperature continue to fall, R-W2 is made through second-stage room-thermostat bulb. Circuit R-W2 energizes a relay, bringing on first bank of supplemental electric heat and providing electrical potential to second heater relay (if used). If

- Restart unit in heating mode, allowing frost to accumulate on outdoor coil.
- After a few minutes in heating mode, liquid-line temperature should drop below closing point of defrost thermostat (approximately 30°F).
- Short between speed-up terminals with a flat-blade screwdriver. (See Fig. 10.) This reduces the timing sequence to 1/256th of original time. (See Table 3.)

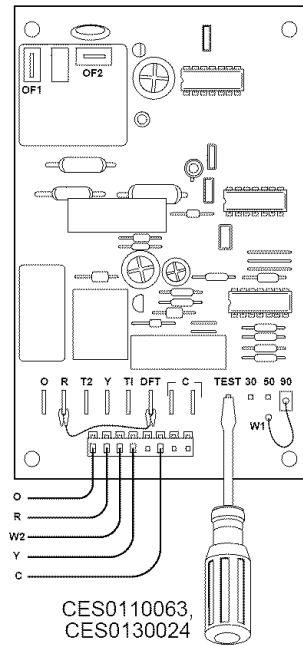

**Table 3—Defrost Control Speedup-Timing Sequence**

PARAMETER	MINIMUM (MINUTES)	MAXIMUM (MINUTES)	SPEEDUP (NOMINAL)
30-minute cycle	27	33	7 sec
50-minute cycle	45	55	12 sec
90-minute cycle	81	99	21 sec
10-minute cycle	9	11	2 sec
5 minutes	4.5	5.5	1 sec

**Fig. 10—Defrost Control**

- When you hear reversing valve change position, remove screwdriver immediately; otherwise, control will terminate normal 10-minute defrost cycle in approximately 2 sec.

**NOTE:** Length of defrost cycle is dependent upon length of time it takes to remove screwdriver from test pins after reversing valve has shifted.

- Unit will remain in defrost for remainder of defrost-cycle time or until defrost thermostat reopens at approximately 80°F coil temperature of liquid line.
- Turn off power to outdoor unit and reconnect fan motor lead to OF2 on control board. (See Fig. 10.)

**Step 14—Check Charge**

Factory charge is shown on unit rating plate. To check charge in cooling mode, refer to Cooling Only Procedure. To check charge in heating mode, refer to Heating Check Chart Procedure.

**COOLING-ONLY PROCEDURE**

**NOTE:** If superheat- or subcooling-charging conditions are not favorable, charge must be weighed in accordance with unit rating plate  $\pm 0.6$  oz/ft of 3/8-in. liquid line above or below 15 ft respectively.

**EXAMPLE:**

To calculate additional charge required for a 25-ft line set:  
 $25 \text{ ft} - 15 \text{ ft} = 10 \text{ ft} \times 0.6 \text{ oz/ft} = 6 \text{ oz}$  of additional charge  
 Units installed with cooling mode TXV require charging with the subcooling method.

- Operate unit a minimum of 10 minutes before checking charge.
- Measure liquid service-valve pressure by attaching an accurate gage to service port.
- Measure liquid-line temperature by attaching an accurate thermistor type or electronic thermometer to liquid line near outdoor coil.
- Refer to unit rating plate for required subcooling temperature.
- Refer to Table 4. Find the point where required subcooling temperature intersects measured liquid service-valve pressure.
- To obtain required subcooling temperature at a specific liquid-line pressure, add refrigerant if liquid-line temperature is higher than indicated or reclaim refrigerant if temperature is lower. Allow a tolerance of  $\pm 3^\circ\text{F}$ .

**Table 4—Required Liquid-Line Temperature (°F)**

LIQUID PRESSURE AT SERVICE VALVE (PSIG)	REQUIRED SUBCOOLING TEMPERATURE (°F)			
	5	10	15	20
134	71	66	61	56
141	74	69	64	59
148	77	72	67	62
156	80	75	70	65
163	83	78	73	68
171	86	81	76	71
179	89	84	79	74
187	92	87	82	77
196	95	90	85	80
205	98	93	88	83
214	101	96	91	86
223	104	99	94	89
233	107	102	97	92
243	110	105	100	95
253	113	108	103	98
264	116	111	106	101
274	119	114	109	104
285	122	117	112	107
297	125	120	115	110
309	128	123	118	113
321	131	126	121	116
331	134	129	124	119
346	137	132	127	122
359	140	135	130	125

**HEATING CHECK CHART PROCEDURE**

To check system operation during heating cycle, refer to the Heating Check Chart on outdoor unit. This chart indicates whether a correct relationship exists between system operating pressure and air temperature entering indoor and outdoor units. If pressure and temperature do not match on chart, system refrigerant charge may not be correct. Do not use chart to adjust refrigerant charge.

**NOTE:** When charging is necessary during heating season, charge must be weighed in accordance with unit rating plate  $\pm 0.6$  oz/ft of 3/8-in. liquid line above or below 15 ft respectively.

EXAMPLE:

To calculate additional charge required for a 25-ft line set:

$25 \text{ ft} - 15 \text{ ft} = 10 \text{ ft} \times 0.6 \text{ oz/ft} = 6 \text{ oz}$  of additional charge

#### Step 15—Final Checks

**IMPORTANT:** Before leaving job, be sure to do the following:

1. Securely fasten all panels and covers.
2. Tighten service valve-stem caps to 1/12-turn past finger-tight.

3. Leave User's Manual with owner. Explain system operation and periodic maintenance requirements outlined in manual.
4. Fill out Dealer Installation Checklist and place in customer file.

#### CARE AND MAINTENANCE

For continuing high performance and to minimize possible equipment failure, periodic maintenance must be performed on this equipment.

Frequency of maintenance may vary depending upon geographic areas, such as coastal applications.