

Operator's Manual

CRAFTSMAN®

ROUTER

Double Insulated

Model Nos.

315.175101

315.175111

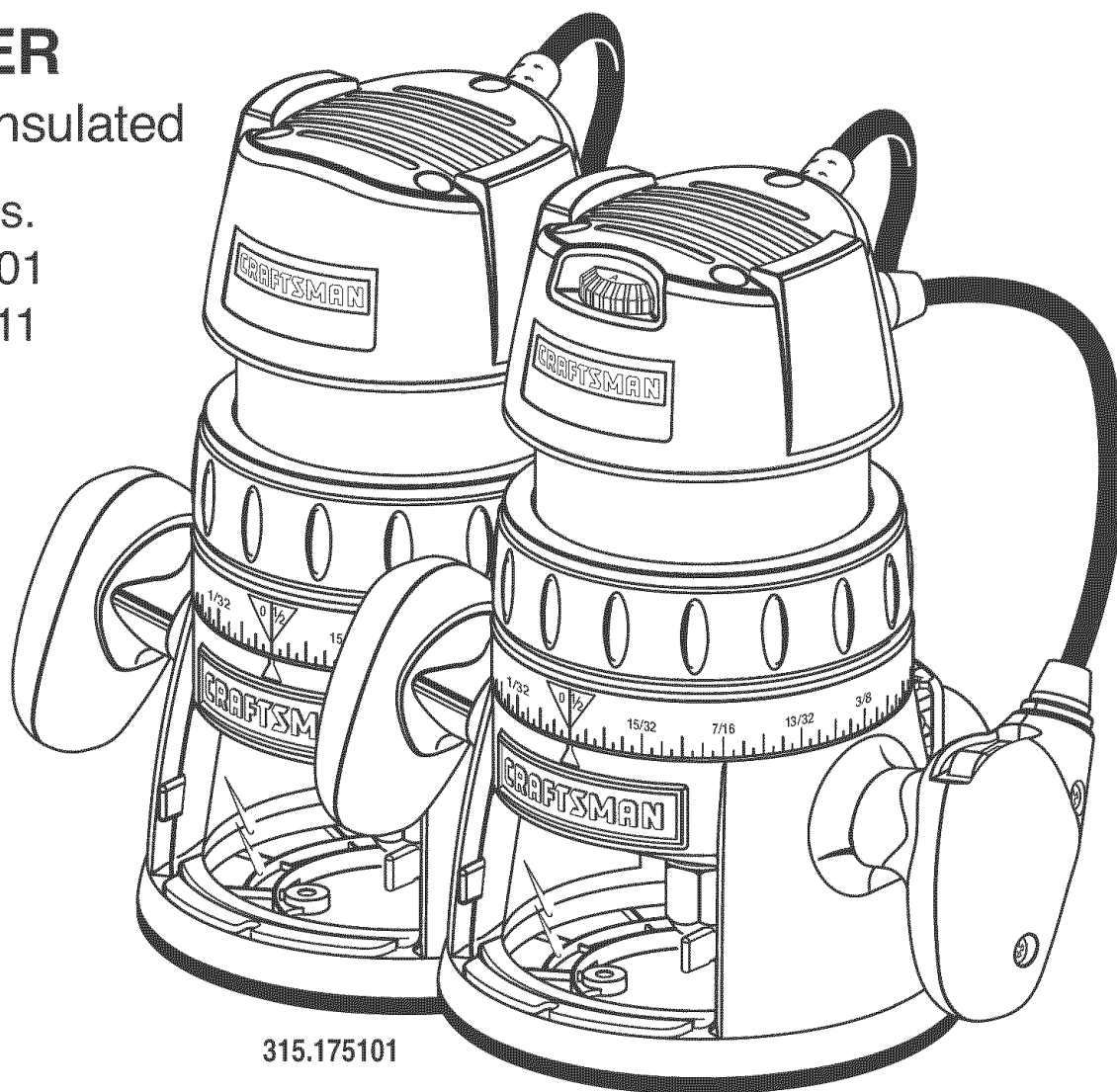

315.175101

315.175111

Save this manual for future reference

⚠ CAUTION: Read and follow all Safety Rules and Operating Instructions before first use of this product.

- Safety
- Features
- Operation
- Maintenance
- Parts List

Customer Help Line: 1-800-932-3188

Sears, Roebuck and Co., 3333 Beverly Rd., Hoffman Estates, IL 60179 USA
Visit the Craftsman Web page: www.sears.com/craftsman



TABLE OF CONTENTS

■ Warranty	2
■ Introduction	2
■ General Safety Rules	3-4
■ Specific Safety Rules	4
■ Symbols	5
■ Specifications	6
■ Unpacking	6
■ Features	7-8
■ Adjustments	9-11
■ Operation	12-17
■ Maintenance	18
■ Accessories	19
■ Exploded View and Repair Parts List	20-21
■ Parts, Ordering, and Service	22

WARRANTY

FULL ONE YEAR WARRANTY ON CRAFTSMAN ROUTER

If this **CRAFTSMAN** Router fails to give complete satisfaction within one year from the date of purchase, **RETURN IT TO THE NEAREST SEARS STORE IN THE UNITED STATES**, and Sears will repair it, free of charge.

If this **CRAFTSMAN** Router is used for commercial or rental purposes, this warranty applies for only 90 days from the date of purchase.

This warranty gives you specific legal rights, and you may also have other rights which vary from state to state.

Sears, Roebuck and Co., Dept. 817 WA, Hoffman Estates, IL 60179

INTRODUCTION

Your router has many features for making routing operations more pleasant and enjoyable. Safety, performance and dependability have been given top priority in the design of this router making it easy to maintain and operate.

 **CAUTION:** Carefully read through this entire operator's manual before using your new router. Pay close attention to the Rules for Safe Operation, Warnings and Cautions. If you use your router properly and only for what it is intended, you will enjoy years of safe, reliable service.

 Look for this symbol to point out important safety precautions. It means attention!!! Your safety is involved.



WARNING: The operation of any router can result in foreign objects being thrown into your eyes, which can result in severe eye damage. Before beginning power tool operation, always wear safety goggles or safety glasses with side shields and a full face shield when needed. We recommend Wide Vision Safety Mask for use over eyeglasses or standard safety glasses with side shields, available at Sears Retail Stores. Always wear eye protection which is marked to comply with ANSI Z87.1.

GENERAL SAFETY RULES

⚠ WARNING: Read and understand all instructions. Failure to follow all instructions listed below, may result in electric shock, fire and/or serious personal injury.

SAVE THESE INSTRUCTIONS

WORK AREA

- **Keep your work area clean and well lit.** Cluttered benches and dark areas invite accidents.
- **Do not operate power tools in explosive atmospheres, such as in the presence of flammable liquids, gases, or dust.** Power tools may create sparks which may ignite the dust or fumes.
- **Keep bystanders, children, and visitors away while operating a power tool.** Distractions can cause you to lose control.

ELECTRICAL SAFETY

- **Double insulated tools are equipped with a polarized plug (one blade is wider than the other). This plug will fit in a polarized outlet only one way. If the plug does not fit fully in the outlet, reverse the plug. If it still does not fit, contact a qualified electrician to install a polarized outlet. Do not change the plug in any way.** Double insulation  eliminates the need for the three-wire grounded power cord and grounded power supply system.
- **Avoid body contact with grounded surfaces, such as pipes, radiators, ranges, and refrigerators.** There is an increased risk of electric shock if your body is grounded.
- **Don't expose power tools to rain or wet conditions.** Water entering a power tool will increase the risk of electric shock.
- **Do not abuse the cord. Never use the cord to carry the tools or pull the plug from an outlet. Keep cord away from heat, oil, sharp edges, or moving parts. Replace damaged cords immediately.** Damaged cords increase the risk of electric shock.
- **When operating a power tool outside, use an outdoor extension cord marked "W-A" or "W".** These cords are rated for outdoor use and reduce the risk of electric shock.

PERSONAL SAFETY

- **Stay alert, watch what you are doing and use common sense when operating a power tool. Do not use tool while tired or under the influence of drugs, alcohol, or medication.** A moment of inattention while operating power tools may result in serious personal injury.
- **Dress properly. Do not wear loose clothing or jewelry. Contain long hair. Keep your hair,**

clothing, and gloves away from moving parts. Loose clothes, jewelry, or long hair can be caught in moving parts.

- **Avoid accidental starting. Be sure switch is off before plugging in.** Carrying tools with your finger on the switch or plugging in tools that have the switch on, invites accidents.
- **Remove adjusting keys or wrenches before turning the tool on.** A wrench or a key that is left attached to a rotating part of the tool may result in personal injury.
- **Do not overreach. Keep proper footing and balance at all times.** Proper footing and balance enables better control of the tool in unexpected situations. Do not use on a ladder or unstable support.
- **Use safety equipment. Always wear eye protection.** Dust mask, non-skid safety shoes, hard hat, or hearing protection must be used for appropriate conditions.

TOOL USE AND CARE

- **Use clamps or other practical way to secure and support the workpiece to a stable platform.** Holding the work by hand or against your body is unstable and may lead to loss of control.
- **Do not force tool. Use the correct tool for your application.** The correct tool will do the job better and safer at the rate for which it is designed.
- **Do not use tool if switch does not turn it on or off.** Any tool that cannot be controlled with the switch is dangerous and must be repaired.
- **Disconnect the plug from power source before making any adjustments, changing accessories, or storing the tool.** Such preventive safety measures reduce the risk of starting the tool accidentally.
- **Store idle tools out of the reach of children and other untrained persons.** Tools are dangerous in the hands of untrained users.
- **Maintain tools with care. Keep cutting tools sharp and clean.** Properly maintained tools with sharp cutting edges are less likely to bind and are easier to control.
- **Check for misalignment or binding of moving parts, breakage of parts, and any other condition that may affect the tool's operation. If damaged, have the tool serviced before using.** Many accidents are caused by poorly maintained tools.
- **Use only accessories that are recommended by the manufacturer for your model.** Accessories that may be suitable for one tool, may become hazardous when used on another tool.

GENERAL SAFETY RULES

SERVICE

- **Tool service must be performed only by qualified repair personnel.** Service or maintenance performed by unqualified personnel could result in a risk of injury.
- **When servicing a tool, use only identical replacement parts. Follow instructions in the Maintenance section of this manual.** Use of unauthorized parts or failure to follow Maintenance Instructions may create a risk of electric shock or injury.

SPECIFIC SAFETY RULES

Hold tool by insulated gripping surfaces when performing an operation where the cutting tool may contact hidden wiring or its cord. Contact with a “live” wire will make exposed metal parts of the tool “live” and shock the operator.

ADDITIONAL RULES FOR SAFE OPERATION

- **Know your power tool. Read operator’s manual carefully. Learn its applications and limitations, as well as the specific potential hazards related to this tool.** Following this rule will reduce the risk of electric shock, fire, or serious injury.
- **Always wear safety glasses. Everyday eye-glasses have only impact-resistant lenses; they are NOT safety glasses.** Following this rule will reduce the risk of serious personal injury.
- **Protect your lungs. Wear a face or dust mask if the operation is dusty.** Following this rule will reduce the risk of serious personal injury.
- **Protect your hearing. Wear hearing protection during extended periods of operation.** Following this rule will reduce the risk of serious personal injury.
- **Inspect tool cords periodically and, if damaged, have repaired at your nearest authorized service center. Constantly stay aware of cord location.** Following this rule will reduce the risk of electric shock or fire.
- **Check damaged parts. Before further use of the tool, a guard or other part that is damaged should be carefully checked to determine that it will operate properly and perform its intended function. Check for alignment of moving parts, binding of moving parts, breakage of parts, mounting, and any other conditions that may affect its operation. A guard or other part that is damaged should be properly repaired or replaced by an authorized service center.** Following this rule will reduce the risk of shock, fire, or serious injury.
- **Do not abuse cord. Never carry the tool by the cord or yank it to disconnect it from the receptacle. Keep cord away from heat, oil, and sharp edges.** Following this rule will reduce the risk of electric shock or fire.
- **Make sure your extension cord is in good condition. When using an extension cord, be sure to use one heavy enough to carry the current your product will draw. A wire gage size (A.W.G.) of at least 16 is recommended for an extension cord 100 feet or less in length. A cord exceeding 100 feet is not recommended. If in doubt, use the next heavier gage. The smaller the gage number, the heavier the cord. An undersized cord will cause a drop in line voltage resulting in loss of power and overheating.**
- **Inspect for and remove all nails from lumber before routing.** Following this rule will reduce the risk of serious personal injury.
- **Drugs, alcohol, medication. Do not operate tool while under the influence of drugs, alcohol, or any medication.** Following this rule will reduce the risk of electric shock, fire, or serious personal injury.
- **Save these instructions. Refer to them frequently and use them to instruct others who may use this tool. If you loan someone this tool, loan them these instructions also.**





WARNING: Some dust created by power sanding, sawing, grinding, drilling, and other construction activities contains chemicals known to cause cancer, birth defects or other reproductive harm. Some examples of these chemicals are:

- lead from lead-based paints,
- crystalline silica from bricks and cement and other masonry products, and
- arsenic and chromium from chemically-treated lumber.

Your risk from these exposures varies, depending on how often you do this type of work. To reduce your exposure to these chemicals: work in a well ventilated area, and work with approved safety equipment, such as those dust masks that are specially designed to filter out microscopic particles.

SYMBOLS

Important: Some of the following symbols may be used on your tool. Please study them and learn their meaning. Proper interpretation of these symbols will allow you to operate the tool better and safer.

SYMBOL	NAME	DESIGNATION/EXPLANATION
V	Volts	Voltage
A	Amperes	Current
Hz	Hertz	Frequency (cycles per second)
W	Watt	Power
min	Minutes	Time
~	Alternating Current	Type or a characteristic of current
n_0	No Load Speed	Rotational speed, at no load
	Class II Construction	Designates double-insulated construction tools
.../min	Revolutions or Reciprocation Per Minute	Revolutions, strokes, surface speed, orbits etc. per minute
	Safety Alert	Indicates danger, warning or caution. It means attention!!! Your safety is involved.
	Wet Conditions Alert	Do not expose to rain or use in damp locations.

The purpose of safety symbols is to attract your attention to possible dangers. The safety symbols, and the explanations with them, deserve your careful attention and understanding. The safety warnings do not by themselves eliminate any danger. The instructions or warnings they give are not substitutes for proper accident prevention measures.

SYMBOL MEANING



DANGER: Failure to obey a safety warning will result in serious injury to yourself or to others. Always follow the safety precautions to reduce the risk of fire, electric shock and personal injury.



WARNING: Failure to obey a safety warning can result in serious injury to yourself or to others. Always follow the safety precautions to reduce the risk of fire, electric shock and personal injury.



CAUTION: Failure to obey a safety warning may result in property damage or personal injury to yourself or to others. Always follow the safety precautions to reduce the risk of fire, electric shock and personal injury.

NOTE: Advises you of information or instructions vital to the operation or maintenance of the equipment.

SAVE THESE INSTRUCTIONS

SPECIFICATIONS

Depth of Cut	0 - 1-1/2 in.	Input	120 Volts, 60 Hz, AC only
Collet	1/4 in.	No Load Speed	
Horsepower		Model No. 315.175101	25,000/min
Model No. 315.175101	1-1/2	Model No. 315.175111	15,000 - 25,000/min
Model No. 315.175111	1-3/4	Power Cord	10 ft.
Ampere		Net Weight	
Model No. 315.175101	8.5 Amps	Model No. 315.175101	7 lbs. 3 oz.
Model No. 315.175111	9.0 Amps	Model No. 315.175111	7 lbs. 9.5 oz.

UNPACKING

Your router has been shipped completely assembled. Inspect it carefully to make sure no breakage or damage has occurred during shipping. If any parts are damaged or missing, contact your nearest Sears Retail Store to obtain replacement parts before attempting to operate router. A wrench and this operator's manual are also included.



WARNING: If any parts are missing, do not operate this tool until the missing parts are replaced. Failure to do so could result in possible serious personal injury.

FEATURES

DOUBLE INSULATION

Double insulation is a concept in safety in electric power tools, which eliminates the need for the usual three-wire grounded power cord. All exposed metal parts are isolated from the internal metal motor components with protecting insulation. Double insulated tools do not need to be grounded.

Important: Servicing of a tool with double insulation requires extreme care and knowledge of the system and should be performed only by a qualified service technician. For service, we suggest you return the tool to your nearest authorized service center for repair. Always use original factory replacement parts when servicing.



WARNING: The double insulated system is intended to protect the user from shock resulting from a break in the tool's internal wiring. Observe all normal safety precautions to avoid electrical shock.

ELECTRIC MOTOR

Your router has a precision built electric motor. It should be connected to a **power supply that is 120 volts, 60 Hz, AC only (normal household current)**. Do not operate this tool on direct current (DC). A substantial voltage drop will cause a loss of power and the motor will overheat. If your tool does not operate when plugged into an outlet, double-check the power supply.

SWITCH

To turn the router **ON**, toggle the switch to the **I** position. To turn the router **OFF**, toggle the switch to the **O** position.

SPINDLE LOCK

The spindle lock secures the spindle while you make adjustments and acts as a retainer to keep the router body from coming out of the base.

DEPTH ADJUSTING RING

The depth adjusting ring allows you to adjust the depth of cut.

LOCKING ARM

The locking arm secures the motor housing in the base.

CHIP SHIELD

A clear plastic chip shield is installed on the front of your router for protection against flying dust and chips. The shield is designed to fit the opening of the router base. If necessary to remove chip shield, squeeze the tabs on each end and pull outward. To replace, squeeze the tabs at each end, fit into opening, then release. **For your protection, do not use router without chip shield properly in place.** Peel the horsepower label from chip shield and discard.

VARIABLE SPEED

(MODEL NO. 315.175111 ONLY)

See Figure 1.

Your router has advanced electronic features, designed to assist you in getting the maximum use from your router. By making proper speed selections, your router can be adjusted to specific routing needs. This eliminates much of the guess work previously needed to perform a given job. Both the experienced and inexperienced router users benefit, obtaining professional like results with fewer job errors.

The variable speed control allows the router speed to be adjusted from 15,000 to 25,000 RPM. The variable speed control selector is conveniently located on the top of the motor housing.

Speed can be set according to the approximate cutter diameter you will be using and to the hardness of the material being cut. The best cuts are made when the cutter is fed through material at the proper rate of feed.

FEATURES

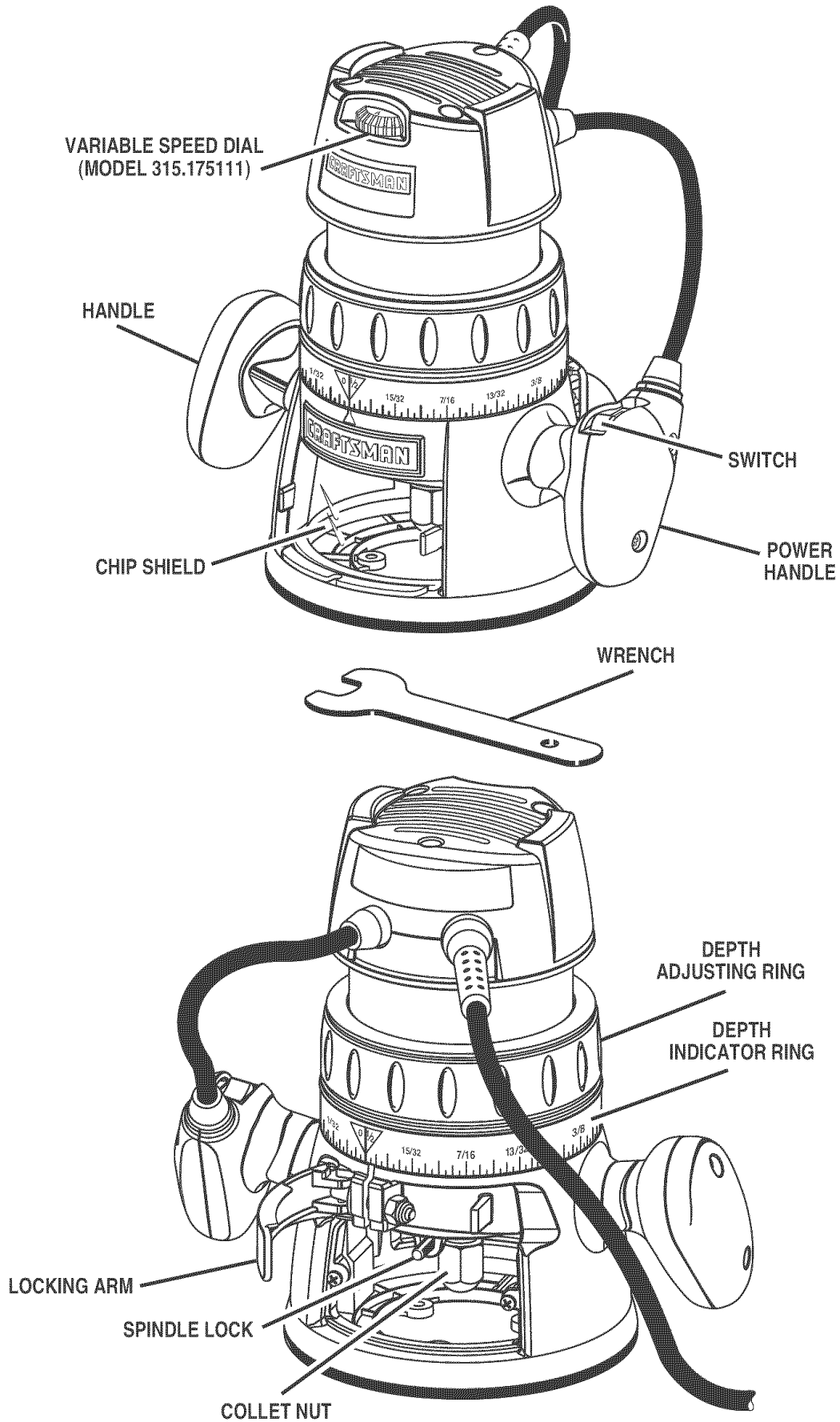

Fig. 1

WARNING: Do not allow familiarity with your router to make you careless. Remember that a careless fraction of a second is sufficient to inflict severe injury.

ADJUSTMENTS

⚠ WARNING: Your router should never be connected to power supply when you are assembling parts, making adjustments, installing or removing cutters, cleaning, or when not in use. Disconnecting router will prevent accidental starting that could cause serious personal injury.

INSTALLING/REMOVING CUTTERS

See Figure 2.

■ Unplug your router.

⚠ WARNING: Failure to unplug your router could result in accidental starting causing serious injury.

■ Depress spindle lock.

⚠ WARNING: To prevent damage to the spindle or spindle lock, always allow motor to come to a complete stop before engaging spindle lock.

- Lay router down on table to gain easy access to collet nut.
- Place wrench provided onto collet nut and turn counterclockwise to loosen.

⚠ WARNING: If you are changing a cutter immediately after use, be careful not to touch the cutter or collet with your hands or fingers. Always use the wrench provided.

- To install cutter: Insert shank of cutter into collet. The shank of the cutter should be close to but not touching bottom of collet.
- To remove cutter: Remove cutter from collet.

NOTE: The collet is machined to precision tolerances to fit cutters with 1/4 in. diameter shanks.

- Tighten the collet nut securely by turning clockwise with wrench provided.
- Release spindle lock.

⚠ WARNING: Do not use cutters with undersized shanks. Undersized shanks will not tighten properly and could be thrown from tool causing injury.

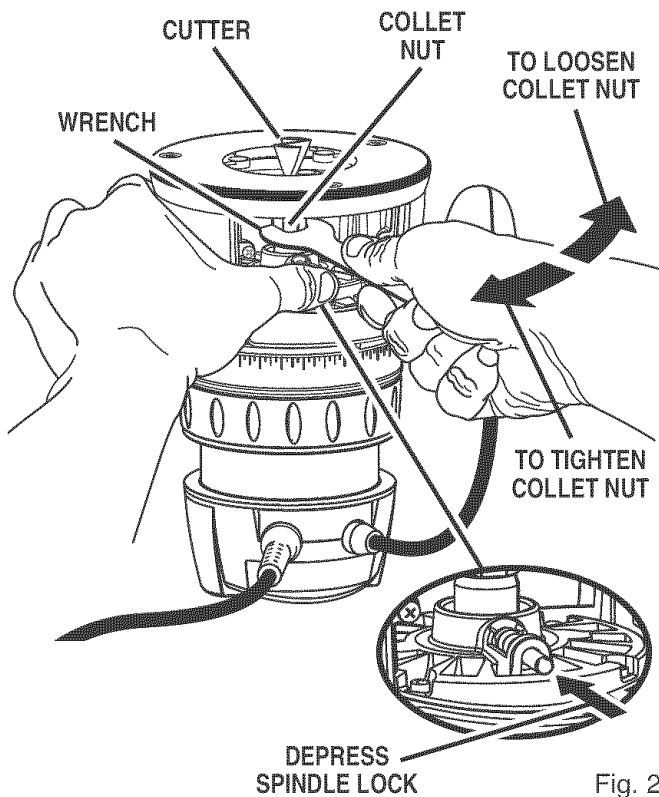

Fig. 2

ADJUSTMENTS

ADJUSTING DEPTH OF CUT

See Figures 3, 4, 5, and 6.

We recommend that cuts be made at a depth not exceeding 1/8 in. and that several passes be made to reach depths of cut greater than 1/8 in.

- Unplug your router.

⚠ WARNING: Failure to unplug your router could result in accidental starting causing serious injury.

- Place router on a flat surface and loosen locking arm. See Figure 3.

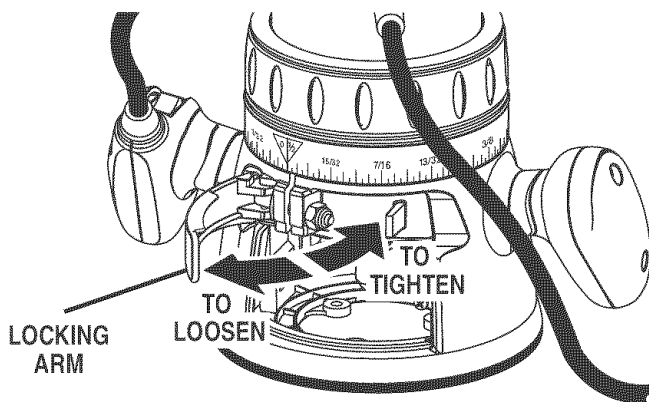

Fig. 3

- Turn depth adjusting ring until cutter is inside subbase. See Figure 4.
- Turn depth adjusting ring until tip of cutter touches flat surface.

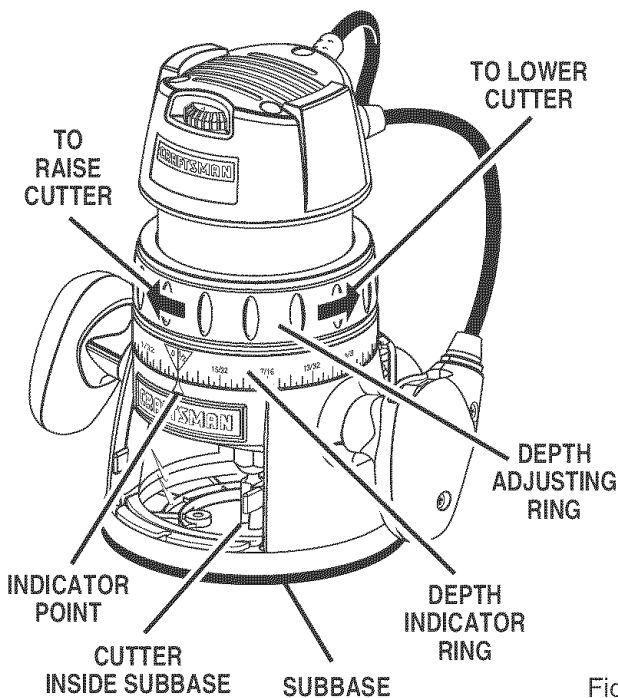

Fig. 4

- Turn the depth indicator ring until the zero lines up with the indicator point on the base. See Figure 5.

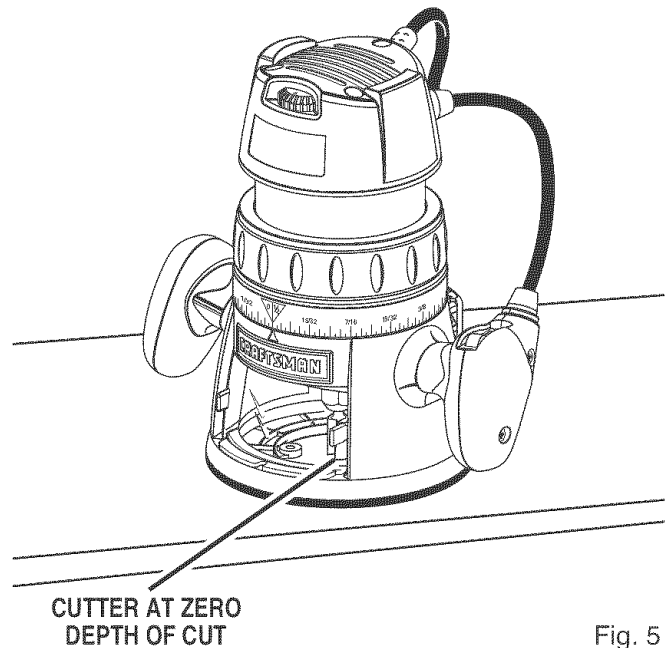

Fig. 5

- Position router so that the cutter can extend below the subbase for desired depth setting. See Figure 6.

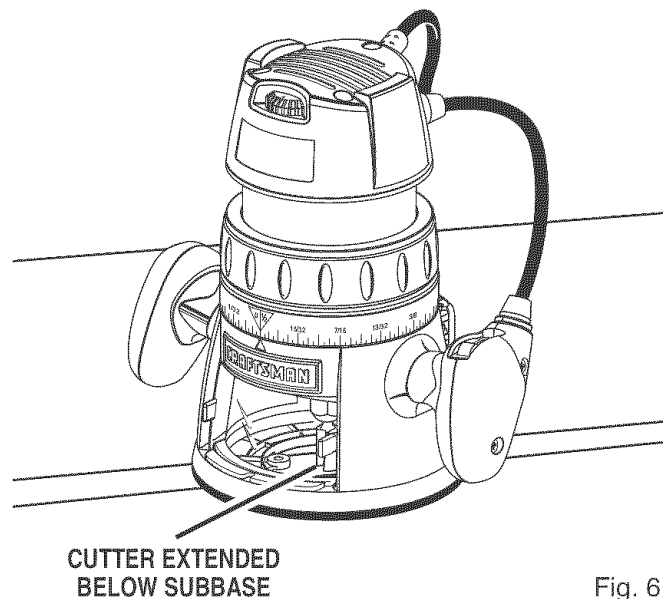

Fig. 6

- Turn the depth adjusting ring to obtain the desired depth of cut.

NOTE: You can read the distance the cutter moves on the depth adjusting ring. Each major mark on the depth adjusting ring indicates 1/32 inch change in depth setting. Each minor mark indicates .0004 in. The indicator point is located on the base.

- Tighten locking arm securely.

ADJUSTMENTS

ADJUSTING DEPTH OF CUT (WITH ROUTER TABLE)

See Figure 7.

The indicator point on the base can be used when using your router mounted to a router table.

- Set the cutter at zero depth of cut.
- Rotate depth indicator ring to desired depth of cut on the scale. Refer to "ADJUSTING DEPTH OF CUT" earlier in this manual.
- Tighten locking arm securely.

FOR ROUTER TABLE USE ONLY

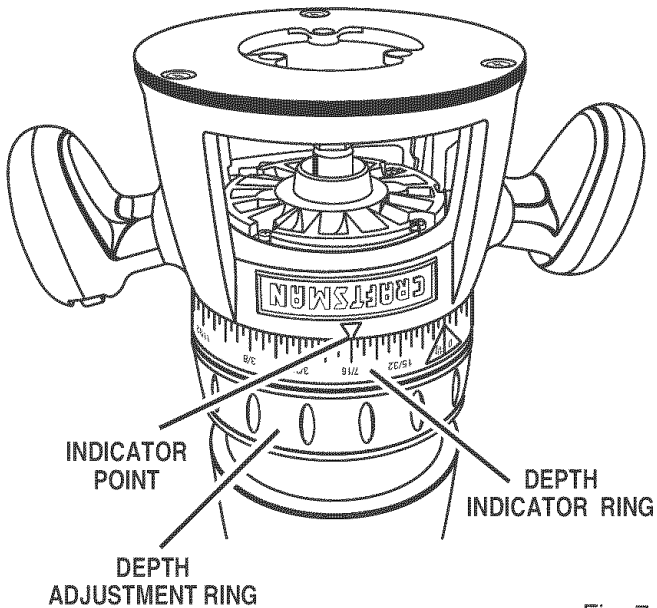

Fig. 7

ADJUSTING SPEED (MODEL NO. 315.175111)

See Figure 8.

Your router has a variable speed control selector designed to allow operator control of speed and torque limits. You can make speed selections best suited to the type of cut, the material being cut, and the size of bit being used. The variable speed control selector allows you to adjust router speed from 15,000 to 25,000 RPM. There is a six-step scale (A to F) on the variable speed control selector. To increase the speed and torque of your router, turn the variable speed control selector to a higher setting (F). Turn to a lower setting to decrease speed and torque.

NOTE: If you do not want to use the variable speed control selector, turn it to the highest possible setting, and the feature will not be active.

The speed selection chart shown gives suggested speed settings based on the diameter of the cutter and the type of material being routed.

SPEED SELECTION CHART				
MATERIAL	CUTTER SIZE			
	1/4	3/8	1/2	3/4
SOFT	E-F	D-E	A-B	A
MEDIUM	D-E	C-D	A	A
HARD	C-D	B-C	A	A
VERY HARD	D-E	C-D	C-D	B-C

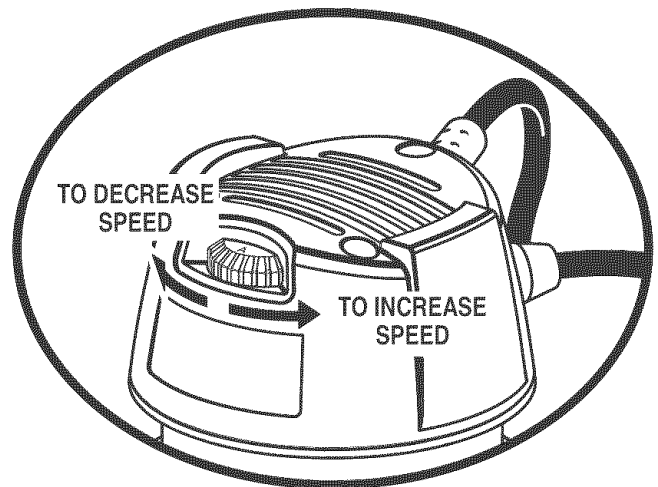

Fig. 8

OPERATION

HELPFUL HINTS

- ✓ Always clamp workpiece securely before routing.
- ✓ A safe operator is one who thinks ahead.
- ✓ Always wear eye protection when routing.
- ✓ Make setup adjustments carefully. Then double check. Measure twice and cut once.
- ✓ Keep cutters clean and properly sharpened.
- ✓ Don't let familiarity make you careless.
- ✓ Study all safety rules and do the job safely.
- ✓ **Never** place your hands in jeopardy.
- ✓ Make certain clamps can't loosen while in use.
- ✓ Test difficult setups on scrap — Don't waste lumber.
- ✓ Plan each operation before you begin.
- ✓ Provide for smoother operation by cleaning your router frequently. Shake router or blow with an air jet to remove sawdust buildup.
- ✓ **Think safety by thinking ahead.**

STARTING/STOPPING ROUTER

- Grasp handles using both hands. See Figure 9a.
- To start router: Toggle the switch to the **I** position. See Figure 9b.
- To stop router: Toggle the switch to the **O** position. See Figure 9b.

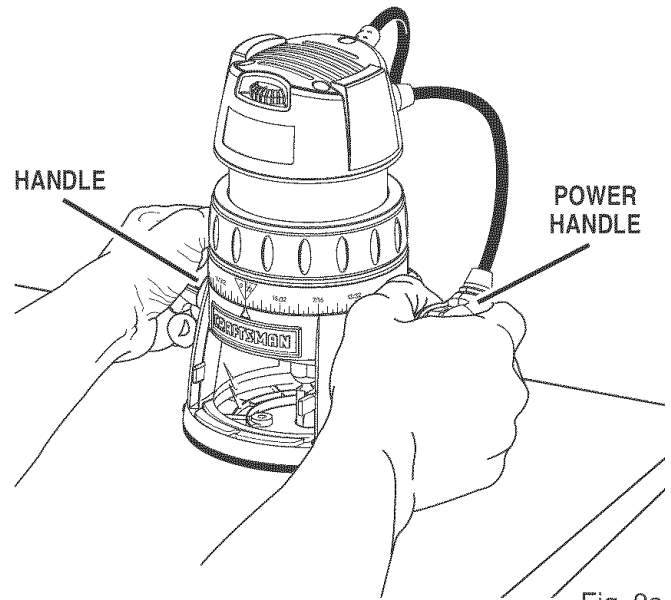

Fig. 9a

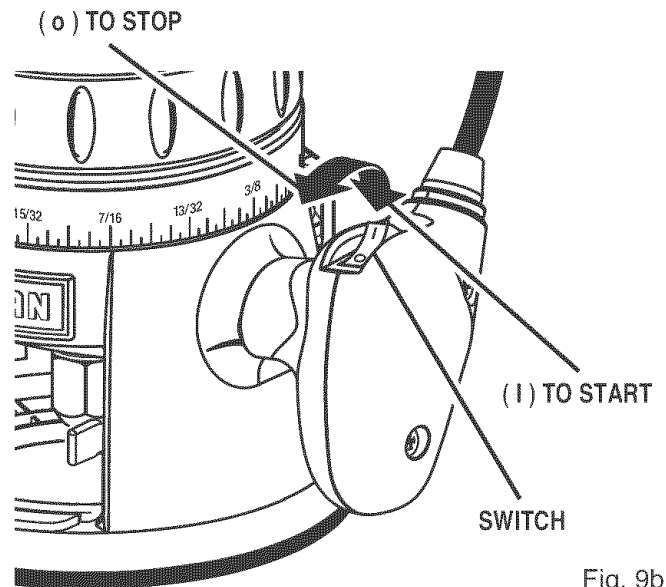



Fig. 9b

OPERATION

PLACING ROUTER ON WORKPIECE

Placing your router on a workpiece differs, depending on the type of routing: edge routing or internal routing.

 **WARNING:** Remain alert and watch what you are doing. **Do not** operate router when fatigued.

EDGE ROUTING

- Place router on edge of workpiece, making sure the router bit does not contact workpiece.
- Turn router on and let motor build to its full speed.
- Begin your cut, gradually feeding cutter into workpiece.

 **WARNING:** Keep a firm grip on router with both hands at all times. Failure to do so could result in loss of control leading to possible serious injury.

- Upon completion of cut, turn motor off and let it come to a complete stop before removing router from work surface.

 **WARNING:** Never pull router out of work and place upside down on work surface before the cutter stops.

INTERNAL ROUTING

- Tilt router and place on workpiece, letting edge of subbase contact workpiece first.

NOTE: Be careful not to let router bit contact workpiece.

- Turn router on and let motor build to its full speed.
- Feed cutter into workpiece gradually until subbase is level with workpiece.

 **WARNING:** Keep a firm grip on router with both hands at all times. Failure to do so could result in loss of control leading to possible serious injury.

- Upon completion of cut, turn motor off and let it come to a complete stop before removing router from work surface.

 **WARNING:** Never pull router out of work and place upside down on work surface before the cutter stops.

FEEDING ROUTER

The “secret” of professional routing and edge shaping lies in making a careful set-up for the cut and in selecting the proper rate of feed.

RATE OF FEED

The proper rate of feed depends on several factors: the hardness and moisture content of the wood, the depth of cut, and the cutting diameter of the bit. When cutting shallow grooves in soft woods such as pine, a faster rate of feed can be used. When making deep cuts in hardwoods such as oak, a slower rate of feed should be used.

The best rate of feed is one that does not slow down the router motor more than one-third of its no-load speed. If the router is fed too fast, it will take large chips out of the wood and leave gouge marks. If the router is fed too slow, it will scorch or burn the wood.

Feeding Too Fast

Clean, smooth routing and edge shaping can be done only when the bit is revolving at a relatively high speed and is taking very small bites to produce tiny, cleanly severed chips. If your router is forced to move forward too fast, the RPM of the bit becomes slower than normal in relation to its forward movement. As a result, the bit must take bigger bites as it revolves. “Bigger bites” mean bigger chips, and a rougher finish. Bigger chips also require more power, which could result in the router motor becoming overloaded.

Under extreme force-feeding conditions the relative RPM of the bit can become so slow—and the bites it has to take so large—that chips will be partially knocked off (rather than fully cut off), resulting in splintering and gouging of the workpiece. See Figure 10.

Your router is an extremely high-speed tool (15,000 - 25,000 RPM no-load speed), and will make clean, smooth cuts if allowed to run freely without the overload of a forced (too fast) feed. Three things that cause “force feeding” are bit size, depth-of-cut, and workpiece characteristics. The larger the bit or the deeper the cut, the more slowly the router should be advanced. If the wood is very hard, knotty, gummy or damp, the operation must be slowed still more.

You can always detect “force feeding” by the sound of the motor. Its high-pitched whine will sound lower and stronger as it loses speed. Also, the strain of holding the tool will be noticeably increased.

OPERATION

Feeding Too Slow

It is also possible to spoil a cut by moving the router forward too slowly. When it is advanced into the work too slowly, a revolving bit does not dig into new wood fast enough to take a bite; instead, it simply scrapes away sawdust-like particles. Scraping produces heat, which can glaze, burn, or mar the cut and in extreme cases, can even overheat the bit so as to destroy its hardness.

In addition, it is more difficult to control a router when the bit is scraping instead of cutting. With practically no load on the motor the bit will be revolving at close to top RPM, and will have a much greater than normal tendency to bounce off the sides of the cut (especially if the wood has a pronounced grain with hard and soft areas). As a result, the cut produced may have rippled, instead of straight sides. See Figure 10.

“Too-slow feeding” can also cause your router to take off in a wrong direction from the intended line of cut.

Always grasp and hold your router firmly with both hands when routing.

You can detect “too-slow feeding” by the runaway, high-pitched sound of the motor; or by feeling the “wobble” of the bit in the cut.

DIRECTION (EXTERNAL)

See Figure 11.

The router motor and bit revolve in a clockwise direction. This gives the tool a slight tendency to twist (in your hands) in a counterclockwise direction, especially when the motor revs up (as at starting).

Because of the extremely high speed of bit rotation during a “proper feeding” operation, there is very little kickback to contend with under normal conditions. However, should the bit strike a knot, hard grain, foreign object, etc. that would affect the normal progress of the cutting action, there will be a slight kickback—sufficient to spoil the trueness of your cut if you are not prepared. Such a kickback is always in the direction opposite to the direction of bit rotation.

To guard against such a kickback, plan your setup and direction of feed so that you will always be thrusting the tool—to hold it against whatever you are using to guide the cut—in the same direction that the leading edge of the bit is moving. In short, the thrust should be in a direction that keeps the sharp edges of the bit continuously biting straight into new (uncut) wood.

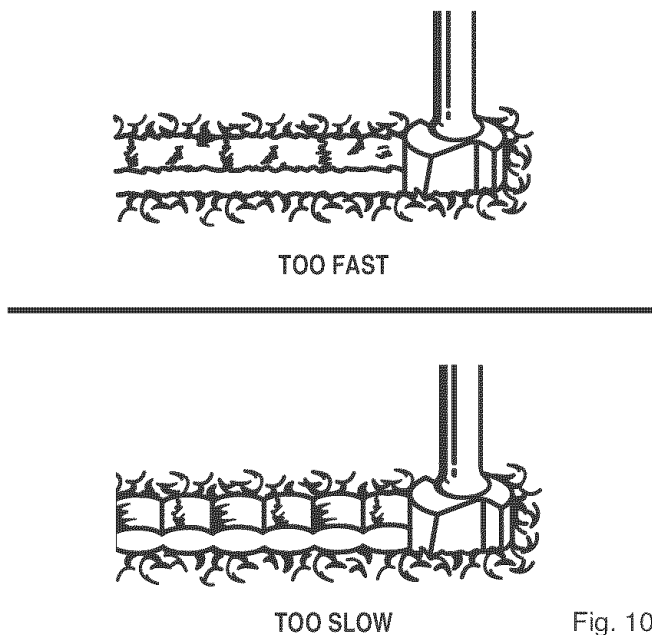
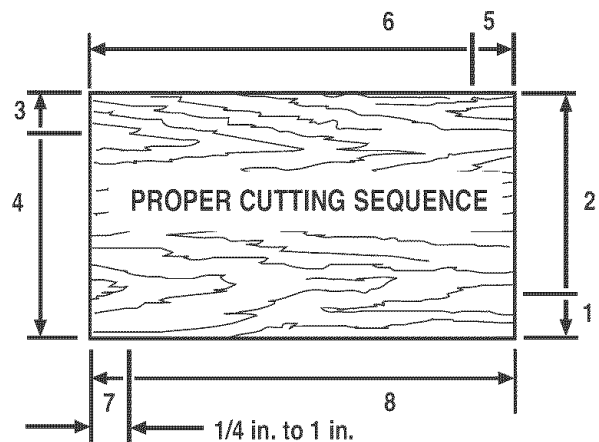

Fig. 10



OPERATION

DIRECTION (INTERNAL)

Whenever you are routing a groove, your travel should be in a direction that places whatever guide you are using at the right-hand side. In short, when the guide is positioned as shown in the first part of Figure 12, tool travel should be left to right and counterclockwise around curves. When the guide is positioned as shown in the second part of Figure 12, tool travel should be right to left and clockwise around curves. If there is a choice, the first setup is generally the easiest to use. In either case, the sideways thrust you use is against the guide.

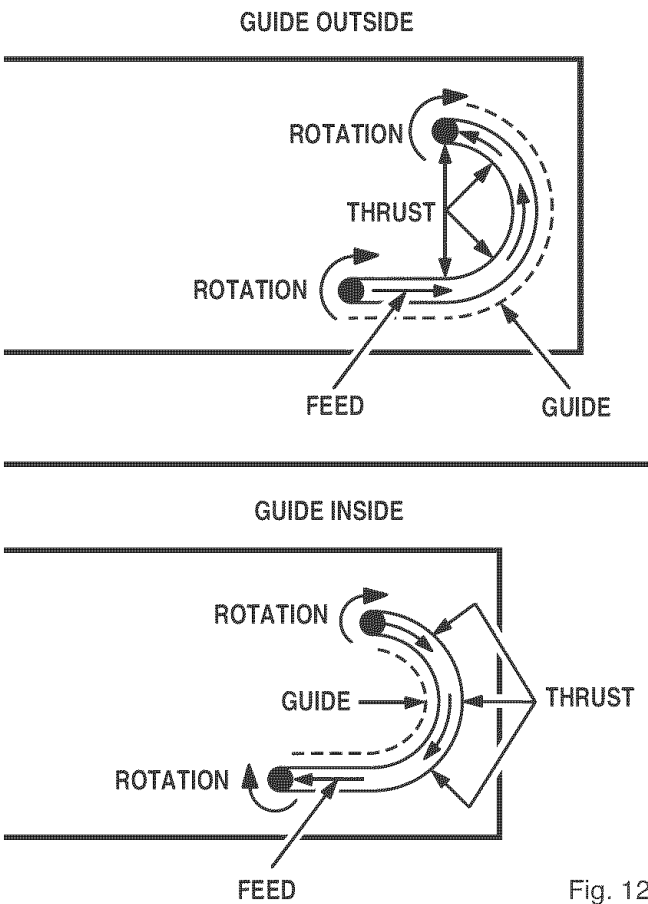

Fig. 12

DETERMINING DEPTH OF CUT

As previously mentioned, the depth of cut is important because it affects the rate of feed that, in turn, affects the quality of the cut (and, also, the possibility of damage to your router motor and bit). A deep cut requires a slower feed than a shallow one, and a too deep cut will cause you to slow the feed so much that the bit is no longer cutting, it is scraping, instead.

Making a deep cut is never advisable. The smaller bits — especially those only 1/16 inch (1.6 mm) in diameter — are easily broken off when subjected to too much side thrust. A large enough bit may not be broken, but if the cut is too deep a rough cut will result — and it may be very difficult to guide and control the bit as desired. For these reasons, we recommend that you do not exceed 1/8 in. depth of cut in a single pass, regardless of the bit size or the softness or condition of the workpiece. See Figure 13.

To make deeper cuts it is therefore necessary to make as many successive passes as required, lowering the bit 1/8 in. for each new pass. In order to save time, do all the cutting necessary at one depth setting, before lowering the bit for the next pass. This will also assure a uniform depth when the final pass is completed. See Figure 14.

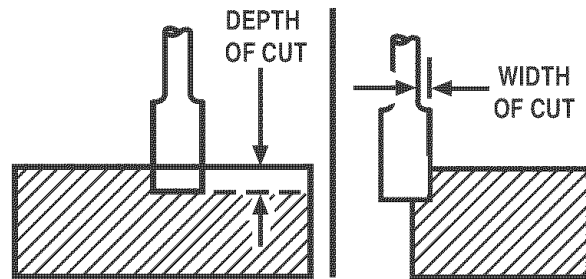

Fig. 13

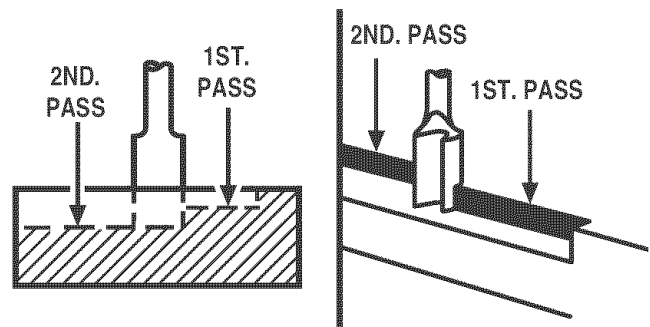

Fig. 14

OPERATION

ROUTING

Your router is a versatile tool and can be used for many different applications. You may rout grooves, carve designs using a template, carve designs by freehand, taper table and chair legs, mortise door jambs, or create joints.

ROUTING GROOVES

See Figure 15.

When routing across the face of boards, set router at desired depth of cut, place the edge of router base against workpiece, and turn on the router. Slowly feed the cutter into the workpiece along desired line of cut.

⚠ WARNING: If desired depth of cut is greater than can be safely cut in one pass, make cuts in two or more passes.

When routing straight cuts across stock, clamp a straight edge to the workpiece to use as a guide. Position the straightedge parallel to the line of cut and offset the distance between the cutting edge of the cutter and the edge of the router base. Hold the router base against the straightedge and rout the groove.

When routing a groove wider than the diameter of the cutter, clamp a straightedge on both sides of the cutlines. Position both guides parallel to the desired line of cut and spaced equal distances from the desired edges of the groove. Rout along one guide; then, reverse direction and rout along the other guide. Clean out any remaining waste in the center of the groove freehand.

ROUTING BY FREEHAND

See Figure 16.

When used freehand, your router becomes a flexible and versatile tool. This flexibility makes it possible to easily rout signs, relief sculptures, etc.

There are two basic techniques for freehand routing:

- Routing letters, grooves, and patterns into wood.
- Routing out the background, leaving the letters or pattern raised above the surface.

When freehand routing, we suggest the following:

- Draw or layout the pattern on workpiece.
- Choose the appropriate cutter.

NOTE: A core box or V-groove bit is often used for routing letters and engraving objects. Straight bits and ball mills are often used to make relief carvings. Veining bits are used to carve small, intricate details.

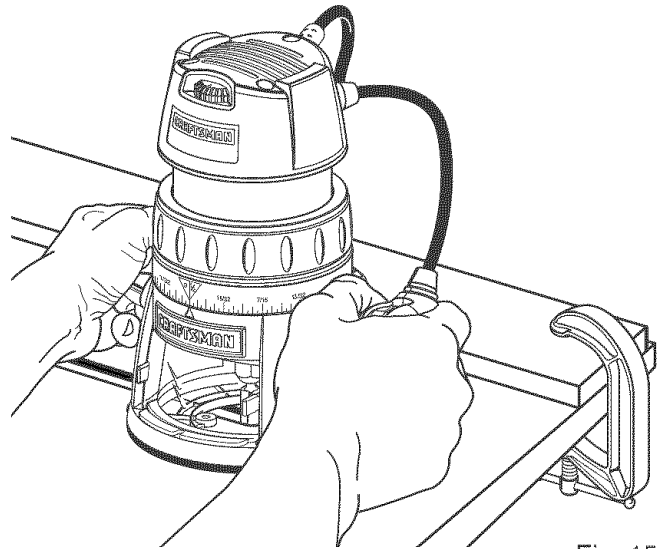

Fig. 15

- Rout the pattern in two or more passes. Make the first pass at 25% of the desired depth of cut. This will provide better control as well as being a guide for the next pass.

NOTE: Do not rout deeper than 1/8 in. per pass.

- ⚠ **WARNING:** Do not use large router bits for freehand routing. Use of large router bits when freehand routing could cause loss of control or create other hazardous conditions that could cause possible serious personal injury. When using a router table, large router bits should be used for edging only. Do not use router bits that are larger in diameter than the opening in router base for any purpose.



Fig. 16

OPERATION

ROUTING WITH GUIDE BUSHINGS

When using the Template Guide Bushings Item No. 9-25082 with your router, you must visually center the bit with the bushing before beginning your cut. Your router subbase may be adjusted by loosening the screws holding the subbase to your router. Be sure to tighten locking arm before centering bit in bushing. After centering bit with bushing, tighten screws securely.

EDGING WITH PILOT BITS

See Figure 17.

Arbor-type bits with pilots are excellent for quick, easy, edge shaping. They will follow workpiece edges that are either straight or curved. The pilot prevents the bit from making too deep a cut; and holding the pilot firmly in contact with the workpiece edge throughout prevents the cut from becoming too shallow.

Whenever the workpiece thickness together with the desired depth of cut (as adjusted by router depth setting) are such that only the top part of the edge is to be shaped (leaving at least a 1/16 inch thick uncut portion at bottom), the pilot can ride against the uncut portion, which will serve to guide it. See Figure 17. However, if the workpiece is too thin or the bit set too low so that there will be no uncut edge to ride the pilot against, an extra board to act as a guide must be placed under the workpiece. This "guide" board must have exactly the same contour — straight or curved — as the workpiece edge. If it is positioned so that its edge is flush with the workpiece edge, the bit will make a full cut (in as far as the bit radius). On the other hand, if the guide is positioned as shown in Figure 17 (out from the workpiece edge), the bit will make less than a full cut — which will alter the shape of the finished edge.

NOTE: Any of the piloted bits can be used without a pilot for edge shaping with guides, as preceding. The size (diameter) of the pilot that is used determines the maximum cut width that can be made with the pilot against the workpiece edge - the small pilot exposes all of the bit; the large one reduces this amount by 1/16 inch.

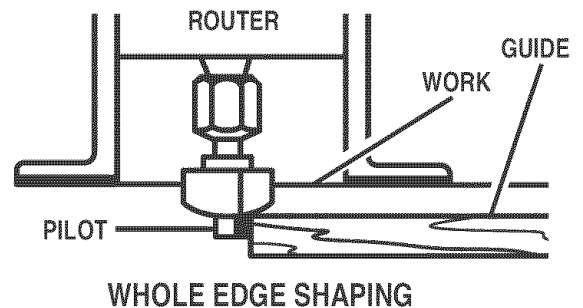
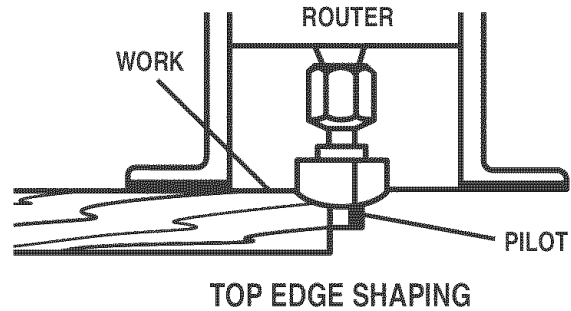



Fig. 17

MAINTENANCE

 **WARNING:** When servicing, use only identical Craftsman replacement parts. Use of any other part may create a hazard or cause product damage.

GENERAL

Only the parts shown on the parts list, are intended to be repaired or replaced by the customer. All other parts represent an important part of the double insulation system and should be serviced only by a qualified Sears service technician.

Avoid using solvents when cleaning plastic parts. Most plastics are susceptible to damage from various types of commercial solvents and may be damaged by their use. Use clean cloths to remove dirt, carbon dust, etc.

 **WARNING:** Do not at any time let brake fluids, gasoline, petroleum-based products, penetrating oils, etc. come in contact with plastic parts. They contain chemicals that can damage, weaken or destroy plastic.

It has been found that electric tools are subject to accelerated wear and possible premature failure when they are used on fiberglass boats, sports cars, wallboard, spackling compounds, or plaster. The chips and grindings from these materials are highly abrasive to electric tool parts such as bearings, brushes, commutators, etc. Consequently, it is not recommended that this tool be used for extended work on any fiberglass material, wallboard, spackling compounds, or plaster. During any use on these materials it is extremely important that the tool is cleaned frequently by blowing with an air jet.

CUTTERS

Get faster more accurate cutting results by keeping cutters clean and sharp. Remove all accumulated pitch and gum from cutters after each use.

When sharpening cutters, sharpen only the inside of the cutting edge. Never grind the outside diameter. Be sure when sharpening the end of a cutter to grind the clearance angle the same as originally ground.

COLLET

From time to time, it also becomes necessary to clean your collet and collet nut. To do so, simply remove collet nut from collet and clean the dust and chips that have collected. Then return collet nut to its original position.

ADJUSTING LOCKING ARM TENSION

Over time and with repeated use, the locking arm may become loose. When this occurs, tighten the elastic stop nut slightly. The elastic stop nut should be loose enough so there is some play in the locking arm when it is in the open position. Make sure the motor housing does not move up or down when clamped.

NOTE: Do not over tighten the elastic stop nut. The locking arm should clamp tightly to secure the motor housing.

If the locking arm becomes worn beyond adjustment, a repair kit is available. Please contact your service center to order the appropriate router locking arm repair kit.

LUBRICATION

All of the bearings in this tool are lubricated with a sufficient amount of high grade lubricant for the life of the unit under normal operating conditions. Therefore, no further lubrication is required.

EXTENSION CORDS

The use of any extension cord will cause some loss of power. To keep the loss to a minimum and to prevent tool overheating, use an extension cord that is heavy enough to carry the current the tool will draw.

A wire gauge size (A.W.G.) of at least **14** is recommended for an extension cord 100 feet or less in length. When working outdoors, use an extension cord that is suitable for outdoor use. The cord's jacket will be marked **WA**.

 **CAUTION:** Keep extension cords away from the cutting area and position the cord so that it will not get caught on lumber, tools, etc., during cutting operation.

 **WARNING:** Check extension cords before each use. If damaged replace immediately. Never use tool with a damaged cord since touching the damaged area could cause electrical shock resulting in serious injury.

Extension cords suitable for use with your router are available at your nearest Sears Retail Store.









 **WARNING:** Always wear safety goggles or safety glasses with side shields during power tool operation or when blowing dust. If operation is dusty, also wear a dust mask.

ACCESSORIES

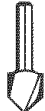
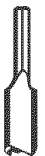
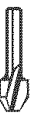
THE FOLLOWING RECOMMENDED ACCESSORIES ARE CURRENTLY AVAILABLE AT SEARS RETAIL STORES.

Dovetail Template
Butt Hinge Template
Multi-Purpose Router Guide

Rout-A-Form Pantograph
Template Set
Template Guide Bushing

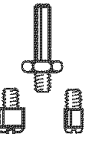
COMBI-NATION PANEL CUTTER 	VEINING BIT 	CORE BOX BIT  V-GROOVE CHAMFER 	STRAIGHT FACE BIT 	COMBI-NATION STRAIGHT, BEVEL CUTTER 	HINGE MORTISING BIT 	DOVETAIL CUTTER BITS 	RABBET BIT 	OGEE, ROMAN O 	COVE BIT, 45° CHAMFER BIT 	BEAD QUARTER-ROUND BIT 	ARBOR WITH BALL BEARINGS 2589  WITH 2 BALL BEARINGS (1/2 in. & 5/8 in.) *25895
* FOR CARBIDE TIPPED EDGE FORMING BITS											
* 25895 FOR CARBIDE TIPPED EDGE FORMING BITS 2589 FOR HIGH SPEED STEEL EDGE FORMING BITS											

WARNING: The use of attachments or accessories not listed above might be hazardous.

ROUTER TABLES

With a router table your router is converted into a high-speed shaper.

WARNING: Only use router tables with proper guarding for the cutter and with "on board" switch controlled receptacles (Part No. 9-25188). Failure to use router tables with appropriate safety features could result in serious personal injury.

VACUUM ATTACHMENT

The vacuum attachment allows you to connect a standard shop vacuum to the router for easy clean up.

GUIDE BUSHINGS

Guide bushings allow for accurate guiding of router along any workpiece or template edge and for grooving or shaping of curved contours.

CRAFTSMAN ROUTER – MODEL NUMBERS 315.175101 and 315.175111

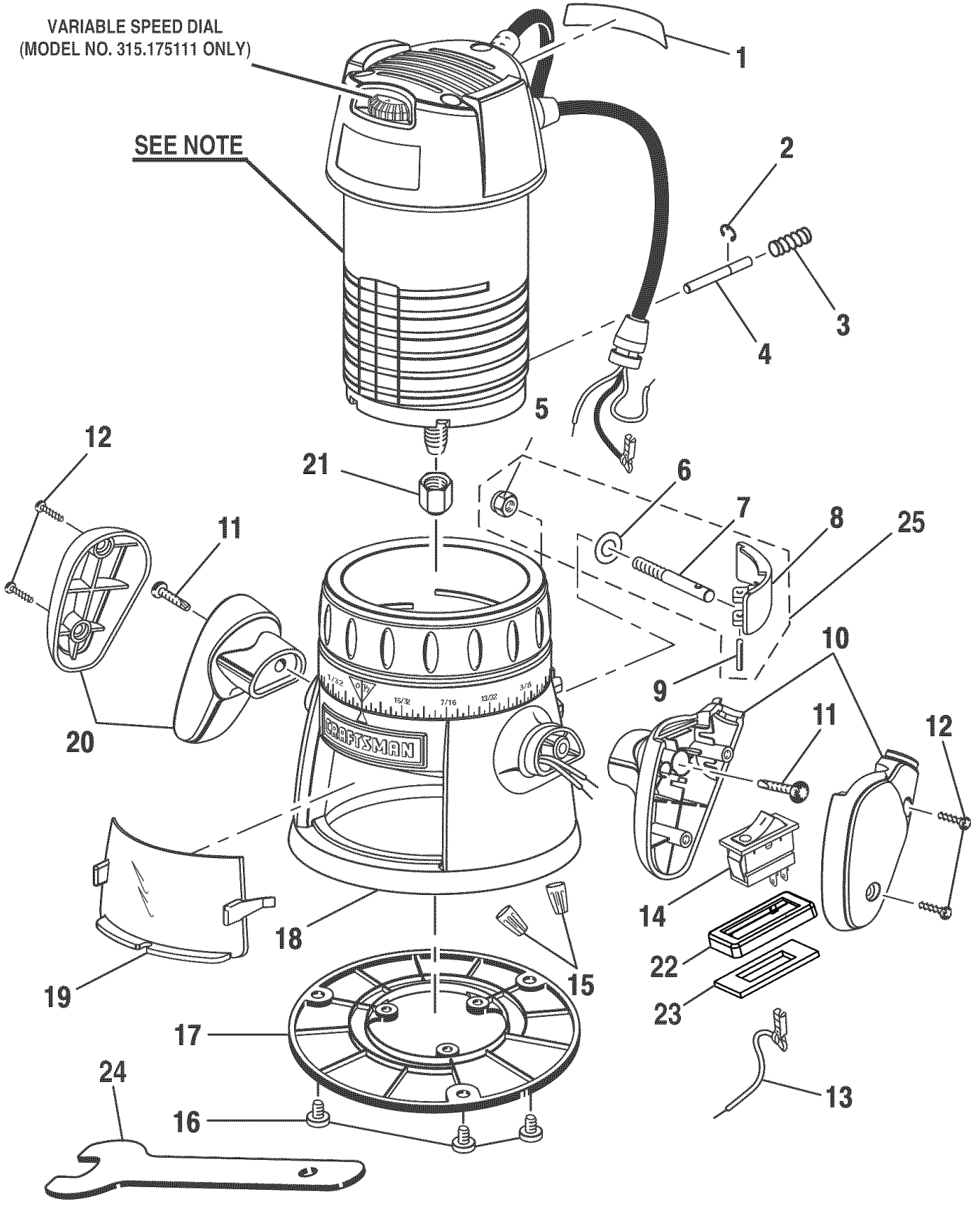

NOTE: The assembly shown represents an important part of the double insulated system. To avoid the possibility of alteration or damage to the system, service should be performed by your nearest Sears repair center. Contact your nearest Sears retail store for service center information.

CRAFTSMAN ROUTER – MODEL NUMBERS 315.175101 and 315.175111

The model number will be found on a plate attached to the motor housing. Always mention the model number in all correspondence regarding your **ROUTER** or when ordering repair parts.

SEE BACK PAGE FOR PARTS ORDERING INSTRUCTIONS

PARTS LIST

Key No.	Part No.	Description	Qty.
1	940301012	Data Plate (Model No. 315.175101)	1
	940301016	Data Plate (Model No. 315.175111)	1
2	671245001	* E-Ring **STD581018	1
3	690141001	Shaft Lock Spring	1
4	671457001	Shaft Lock Pin	1
5	671243001	* Hex Lock Nut (#1/4-20) **STD541425	1
6	631123001	Washer	1
7	671260001	Lock Stud	1
8	640676001	Lock Lever	1
9	671247001	Pin	1
10	200236001	Power Handle Assembly	1
11	660062005	* Screw (#10-24 x 9/16 in. Pan Hd.)	2
12	660161001	Screw (#8-10 x 5/8 in. Pan Hd.)	4
13	290061048	Lead	1
14	760357001	Switch	1
15	870126002	* Wire Nut **STD375004	2
16	660136001	Screw (#10-32 x 1/4 in. Pan Hd.) **STD511102	3
17	511983001	Subbase	1
18	200234001	Base Assembly	1
19	511987001	Chip Shield	1
20	200235001	Handle Assembly	1
21	690190001	Collet Nut	1
22	512546001	Bezel	1
23	900515001	Switch Felt	1
24	671250001	Wrench	1
25	000727001	Lock Lever Repair Kit	1
	983000-430	Operator's Manual	1

* Standard Hardware Item – May Be Purchased Locally
 ** Available From Div. 98 – Source 980.00

Get it fixed, at your home or ours!

Your Home

For repair – **in your home** – of **all** major brand appliances, lawn and garden equipment, or heating and cooling systems, **no matter who made it, no matter who sold it!**

For the replacement parts, accessories and owner's manuals that you need to do-it-yourself.

For Sears professional installation of home appliances and items like garage door openers and water heaters.

1-800-4-MY-HOME[®] (1-800-469-4663)

Call anytime, day or night (U.S.A. and Canada)

www.sears.com www.sears.ca

Our Home

For repair of carry-in items like vacuums, lawn equipment, and electronics, call or go on-line for the location of your nearest **Sears Parts & Repair Center.**

1-800-488-1222

Call anytime, day or night (U.S.A. only)

www.sears.com

To purchase a protection agreement (U.S.A.) or maintenance agreement (Canada) on a product serviced by Sears:

1-800-827-6655 (U.S.A.)

1-800-361-6665 (Canada)

Para pedir servicio de reparación a domicilio, y para ordenar piezas:

1-888-SU-HOGARSM

(1-888-784-6427)

Au Canada pour service en français:

1-800-LE-FOYER^{MC}

(1-800-533-6937)

www.sears.ca

SEARS