

OPERATOR'S MANUAL

CRAFTSMAN®

1/3 SHEET SANDER DOUBLE INSULATED

Model No.
315.116920

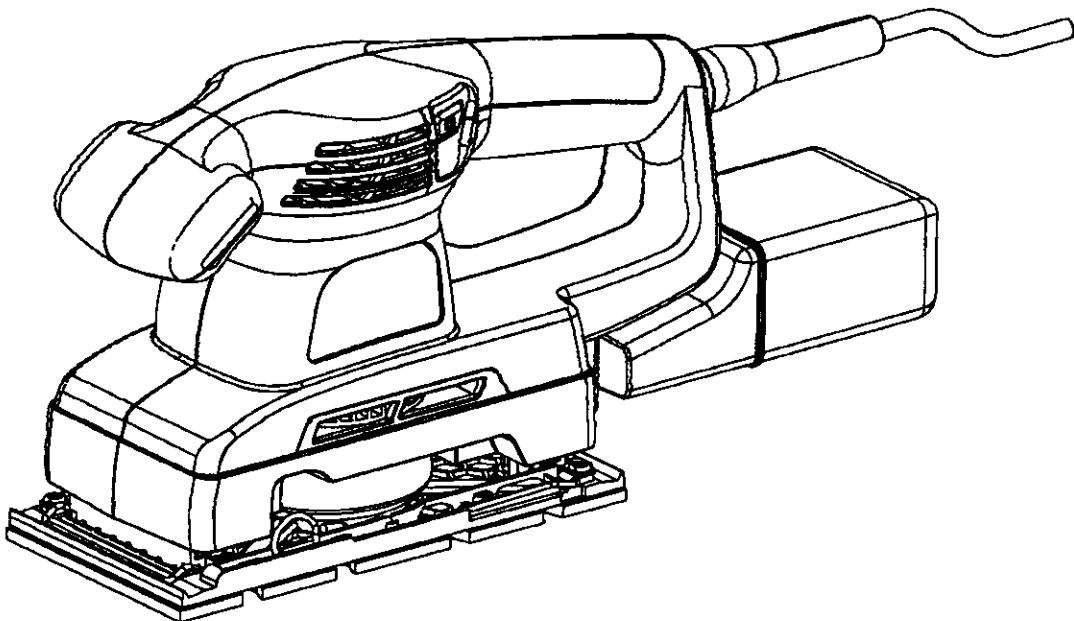

WARNING: To reduce the risk of injury,
the user must read and understand the
operator's manual before using this product.

Customer Help Line: 1-800-932-3188

Sears, Roebuck and Co., 3333 Beverly Rd., Hoffman Estates, IL 60179 USA
Visit the Craftsman web page: www.sears.com/craftsman

983000-494
7-04

Save this manual for future reference



TABLE OF CONTENTS

■ Warranty	2
■ Introduction	2
■ General Safety Rules	3-4
■ Specific Safety Rules.....	4
■ Symbols.....	5-6
■ Electrical	7
■ Features.....	8
■ Assembly	9
■ Operation.....	9-12
■ Maintenance.....	13
■ Accessories	13
■ Exploded View and Parts List.....	14-15
■ Parts Ordering/Service	Back Page

WARRANTY

ONE YEAR FULL WARRANTY ON CRAFTSMAN TOOL

If this Craftsman tool fails to give complete satisfaction within one year from date of purchase, **RETURN IT TO THE NEAREST SEARS STORE IN THE UNITED STATES**, and Sears will replace it, free of charge.

If this Craftsman tool is used for commercial or rental purposes, this warranty applies for only 90 days from the date of purchase.

This warranty gives you specific legal rights, and you may also have other rights which vary from state to state.

Sears, Roebuck and Co., Dept. 817 WA, Hoffman Estates, IL 60179

INTRODUCTION

This tool has many features for making its use more pleasant and enjoyable. Safety, performance, and dependability have been given top priority in the design of this product making it easy to maintain and operate.

GENERAL SAFETY RULES

⚠ WARNING: Read and understand all instructions. Failure to follow all instructions listed below, may result in electric shock, fire and/or serious personal injury.

SAVE THESE INSTRUCTIONS

WORK AREA

- **Keep your work area clean and well lit.** Cluttered benches and dark areas invite accidents.
- **Do not operate power tools in explosive atmospheres, such as in the presence of flammable liquids, gases, or dust.** Power tools create sparks which may ignite the dust or fumes.
- **Keep bystanders, children, and visitors away while operating a power tool.** Distractions can cause you to lose control.

ELECTRICAL SAFETY

- **Double insulated tools are equipped with a polarized plug (one blade is wider than the other). This plug will fit in a polarized outlet only one way. If the plug does not fit fully in the outlet, reverse the plug. If it still does not fit, contact a qualified electrician to install a polarized outlet. Do not change the plug in any way.** Double insulation eliminates the need for the three-wire grounded power cord and grounded power supply system.
- **Avoid body contact with grounded surfaces such as pipes, radiators, ranges, and refrigerators.** There is an increased risk of electric shock if your body is grounded.
- **Don't expose power tools to rain or wet conditions.** Water entering a power tool will increase the risk of electric shock.
- **Do not abuse the cord. Never use the cord to carry the tools or pull the plug from an outlet. Keep cord away from heat, oil, sharp edges, or moving parts. Replace damaged cords immediately.** Damaged cords increase the risk of electric shock.
- **When operating a power tool outside, use an outdoor extension cord marked "W-A" or "W".** These cords are rated for outdoor use and reduce the risk of electric shock.

PERSONAL SAFETY

- **Stay alert, watch what you are doing and use common sense when operating a power tool. Do not use tool while tired or under the influence of drugs, alcohol, or medication.** A moment of inattention while operating power tools may result in serious personal injury.
- **Dress properly. Do not wear loose clothing or jewelry. Contain long hair. Keep your hair, clothing, and gloves away from moving parts.** Loose clothes, jewelry, or long hair can be caught in moving parts.

- **Avoid accidental starting. Be sure switch is off before plugging in.** Carrying tools with your finger on the switch or plugging in tools that have the switch on invites accidents.
- **Remove adjusting keys or wrenches before turning the tool on.** A wrench or a key that is left attached to a rotating part of the tool may result in personal injury.
- **Do not overreach. Keep proper footing and balance at all times.** Proper footing and balance enables better control of the tool in unexpected situations.
- **Use safety equipment. Always wear eye protection.** Dust mask, nonskid safety shoes, hard hat, or hearing protection must be used for appropriate conditions.
- **Do not wear loose clothing or jewelry. Contain long hair.** Loose clothes, jewelry, or long hair can be drawn into air vents.
- **Do not use on a ladder or unstable support.** Stable footing on a solid surface enables better control of the tool in unexpected situations.

TOOL USE AND CARE

- **Use clamps or other practical way to secure and support the workpiece to a stable platform.** Holding the work by hand or against your body is unstable and may lead to loss of control.
- **Do not force tool. Use the correct tool for your application.** The correct tool will do the job better and safer at the rate for which it is designed.
- **Do not use tool if switch does not turn it on or off.** Any tool that cannot be controlled with the switch is dangerous and must be repaired.
- **Disconnect the plug from power source before making any adjustments, changing accessories, or storing the tool.** Such preventive safety measures reduce the risk of starting the tool accidentally.
- **Store idle tools out of the reach of children and other untrained persons.** Tools are dangerous in the hands of untrained users.
- **Maintain tools with care. Keep cutting tools sharp and clean.** Properly maintained tools with sharp cutting edges are less likely to bind and are easier to control.
- **Check for misalignment or binding of moving parts, breakage of parts, and any other condition that may affect the tool's operation. If damaged, have the tool serviced before using.** Many accidents are caused by poorly maintained tools.
- **Use only accessories that are recommended by the manufacturer for your model.** Accessories that may be suitable for one tool, may become hazardous when used on another tool.
- **Keep the tool and its handle dry, clean and free from oil and grease.** Always use a clean cloth when cleaning. Never use brake fluids, gasoline, petroleum-based products, or any strong solvents to clean your tool. Following this rule will reduce the risk of loss of control and deterioration of the enclosure plastic.

GENERAL SAFETY RULES

SERVICE

- **Tool service must be performed only by qualified repair personnel.** Service or maintenance performed by unqualified personnel may result in a risk of injury.
- **When servicing a tool, use only identical replacement parts.** Follow instructions in the Maintenance section of this manual. Use of unauthorized parts or failure to follow Maintenance Instructions may create a risk of shock or injury.

SPECIFIC SAFETY RULES

- **Hold tool by insulated gripping surfaces when performing an operation where the cutting tool may contact hidden wiring or its own cord.** Contact with a "live" wire will make exposed metal parts of the cutting tool "live" and shock the operator.
- **Never use this or any power sander for wet sanding or liquid polishing.** Failure to comply will increase the risk of electrical shock.
- **Know your power tool. Read operator's manual carefully. Learn its applications and limitations, as well as the specific potential hazards related to this tool.** Following this rule will reduce the risk of electric shock, fire, or serious injury.
- **Always wear safety glasses. Everyday eyeglasses have only impact-resistant lenses; they are NOT safety glasses.** Following this rule will reduce the risk of serious personal injury.
- **Protect your lungs. Wear a face or dust mask if the operation is dusty.** Following this rule will reduce the risk of serious personal injury.
- **Protect your hearing. Wear hearing protection during extended periods of operation.** Following this rule will reduce the risk of serious personal injury.
- **Inspect tool cords periodically and, if damaged, have repaired at your nearest Authorized Service Center. Constantly stay aware of cord location.** Following this rule will reduce the risk of electric shock or fire.
- **Check damaged parts. Before further use of the tool, a guard or other part that is damaged should be carefully checked to determine that it will operate properly and perform its intended function. Check for alignment of moving parts, binding of moving parts, breakage of parts, mounting, and any other conditions that may affect its operation. A guard or other part that is damaged should be properly repaired or replaced by an authorized service center.** Following this rule will reduce the risk of shock, fire, or serious injury.
- **Make sure your extension cord is in good condition. When using an extension cord, be sure to use one heavy enough to carry the current your product will draw. A wire gauge size (A.W.G.) of at least 16 is recommended for an extension cord 100 feet or less in length. A cord exceeding 100 feet is not recommended. If in doubt, use the next heavier gauge. The smaller the gauge number, the heavier the cord. An undersized cord will cause a drop in line voltage resulting in loss of power and overheating.**
- **Inspect for and remove all nails from lumber before using this tool.** Following this rule will reduce the risk of serious personal injury.
- **Save these instructions.** Refer to them frequently and use them to instruct others who may use this tool. If you loan someone this tool, loan them these instructions also.











 **WARNING:** Some dust created by power sanding, sawing, grinding, drilling, and other construction activities contains chemicals known to cause cancer, birth defects or other reproductive harm. Some examples of these chemicals are:

- lead from lead-based paints,
- crystalline silica from bricks and cement and other masonry products, and
- arsenic and chromium from chemically-treated lumber.

Your risk from these exposures varies, depending on how often you do this type of work. To reduce your exposure to these chemicals: work in a well ventilated area, and work with approved safety equipment, such as those dust masks that are specially designed to filter out microscopic particles.



SYMBOLS

Some of the following symbols may be used on this tool. Please study them and learn their meaning. Proper interpretation of these symbols will allow you to operate the tool better and safer.

SYMBOL	NAME	DESIGNATION/EXPLANATION
V	Volts	Voltage
A	Amperes	Current
Hz	Hertz	Frequency (cycles per second)
W	Watt	Power
min	Minutes	Time
~	Alternating Current	Type of current
=	Direct Current	Type or a characteristic of current
n_0	No Load Speed	Rotational speed, at no load
	Class II Construction	Double-Insulated construction
.../min	Per Minute	Revolutions, strokes, surface speed, orbits etc., per minute
	Wet Conditions Alert	Do not expose to rain or use in damp locations.
	Read The Operator's Manual	To reduce the risk of injury, user must read and understand operator's manual before using this product.
	Eye Protection	Always wear safety goggles or safety glasses with side shields and a full face shield when operating this product.
	Safety Alert	Precautions that involve your safety.
	No Hands Symbol	Failure to keep your hands away from the blade will result in serious personal injury.
	No Hands Symbol	Failure to keep your hands away from the blade will result in serious personal injury.
	No Hands Symbol	Failure to keep your hands away from the blade will result in serious personal injury.
	No Hands Symbol	Failure to keep your hands away from the blade will result in serious personal injury.
	Hot Surface	To reduce the risk of injury or damage, avoid contact with any hot surface.

SYMBOLS

The following signal words and meanings are intended to explain the levels of risk associated with this product.

SYMBOL	SIGNAL	MEANING
	DANGER:	Indicates an imminently hazardous situation, which, if not avoided, will result in death or serious injury.
	WARNING:	Indicates a potentially hazardous situation, which, if not avoided, could result in death or serious injury.
	CAUTION:	Indicates a potentially hazardous situation, which, if not avoided, may result in minor or moderate injury.
	CAUTION:	(Without Safety Alert Symbol) Indicates a situation that may result in property damage.

SERVICE

Servicing requires extreme care and knowledge and should be performed only by a qualified service technician. For service we suggest you return the product to your nearest **AUTHORIZED SERVICE CENTER** for repair. When servicing, use only identical replacement parts.

 **WARNING:** To avoid serious personal injury, do not attempt to use this product until you read thoroughly and understand completely the operator's manual. Save this operator's manual and review frequently for continuing safe operation and instructing others who may use this product.

WARNING:



The operation of any power tool can result in foreign objects being thrown into your eyes, which can result in severe eye damage. Before beginning power tool operation, always wear safety goggles or safety glasses with side shields and a full face shield when needed. We recommend Wide Vision Safety Mask for use over eyeglasses or standard safety glasses with side shields. Always use eye protection which is marked to comply with ANSI Z87.1.

SAVE THESE INSTRUCTIONS

ELECTRICAL

DOUBLE INSULATION

Double insulation is a concept in safety in electric power tools, which eliminates the need for the usual three-wire grounded power cord. All exposed metal parts are isolated from the internal metal motor components with protecting insulation. Double insulated tools do not need to be grounded.

 **WARNING:** The double insulated system is intended to protect the user from shock resulting from a break in the tool's internal insulation. Observe all normal safety precautions to avoid electrical shock.

NOTE: Servicing of a tool with double insulation requires extreme care and knowledge of the system and should be performed only by a qualified service technician. For service, we suggest you return the tool to your nearest authorized service center for repair. Always use original factory replacement parts when servicing.

ELECTRICAL CONNECTION

This tool has a precision-built electric motor. It should be connected to a power supply that is 120 volts, 60 Hz, AC only (normal household current). Do not operate this tool on direct current (DC). A substantial voltage drop will cause a loss of power and the motor will overheat. If your tool does not operate when plugged into an outlet, double-check the power supply.

EXTENSION CORDS

When using a power tool at a considerable distance from a power source, be sure to use an extension cord that has the capacity to handle the current the tool will draw. An undersized cord will cause a drop in line voltage, resulting in overheating and loss of power. Use the chart to determine the minimum wire size required in an extension cord. Only round jacketed cords listed by Underwriter's Laboratories (UL) should be used.

When working outdoors with a tool, use an extension cord that is designed for outside use. This type of cord is designated with "WA" on the cord's jacket.

Before using any extension cord, inspect it for loose or exposed wires and cut or worn insulation.

**Ampere rating (on tool faceplate)

Cord Length	Wire Size (A.W.G.)					
	0-2.0	2.1-3.4	3.5-5.0	5.1-7.0	7.1-12.0	12.1-16.0
25'	16	16	16	16	14	14
50'	16	16	16	14	14	12
100'	16	16	14	12	10	—

**Used on 12 gauge - 20 amp circuit

NOTE: AWG = American Wire Gauge

 **WARNING:** Keep the extension cord clear of the working area. Position the cord so that it will not get caught on lumber, tools or other obstructions while you are working with a power tool. Failure to do so can result in serious personal injury.

 **WARNING:** Check extension cords before each use. If damaged replace immediately. Never use tool with a damaged cord since touching the damaged area could cause electrical shock resulting in serious injury.

FEATURES

PRODUCT SPECIFICATIONS

Orbit Diameter	1/16 in.	No Load Speed	12,000/min.
Size of Paper	1/3 Sheet	Input	120 V, 60 Hz, AC only, 2.0 Amps
Paper Type	Non-Adhesive Sandpaper Adhesive Sandpaper	Net Weight.....	4 lbs.
		Vacuum hose adapter	1-1/4 in.

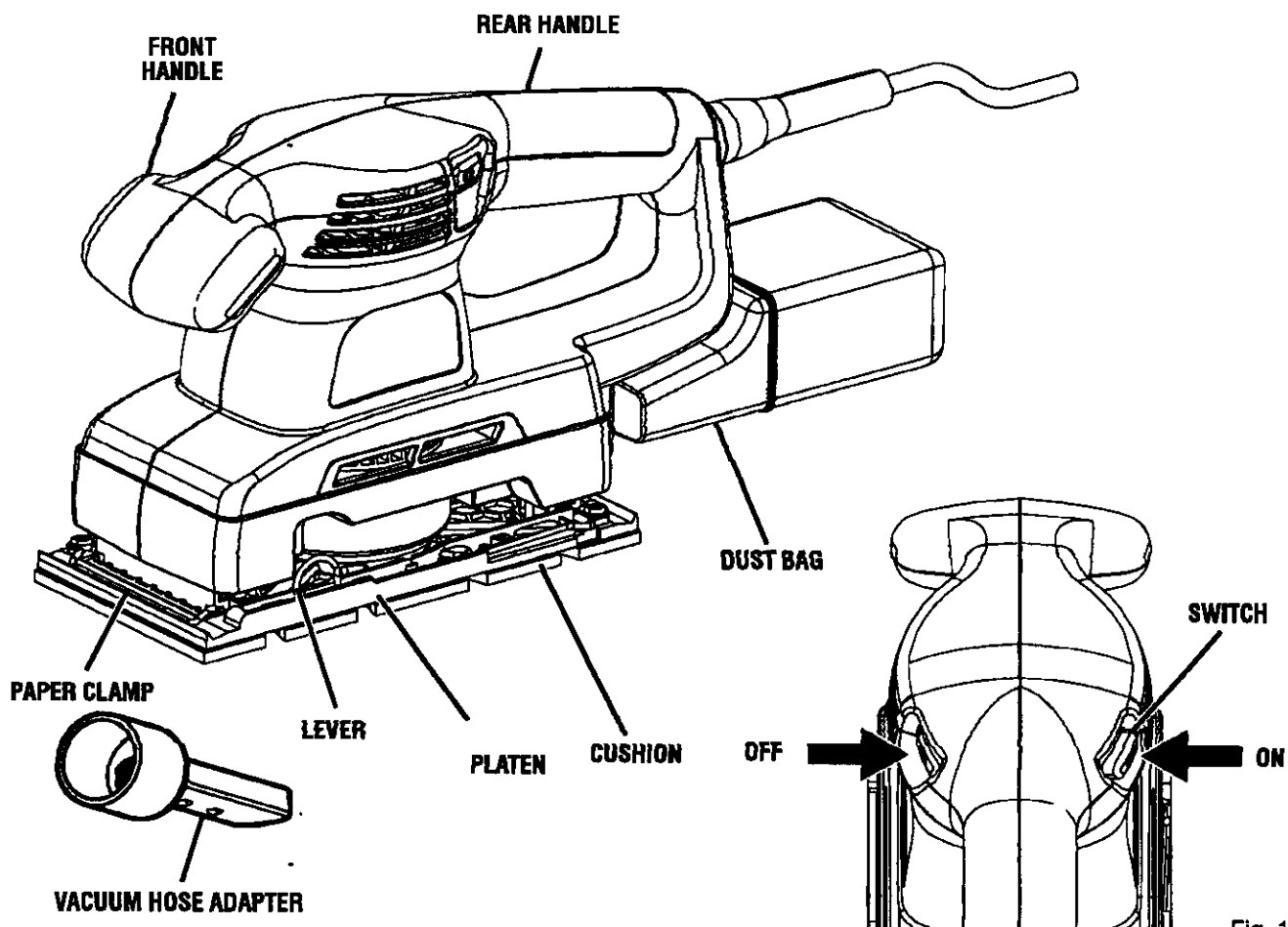

Fig. 1

KNOW YOUR SANDER

See Figure 1.

Before attempting to use this product, familiarize yourself with all operating features and safety rules.

The sander is suitable for sanding with coarse, medium, and fine grit sandpaper. It will produce a fine, scratch-free finish when used to sand with the grain on wood surfaces. It has also been designed so that sanding flush to corners is possible.

SWITCH

The sander has a conveniently located sealed slide switch to keep out dust for longer life.

PAPER CLAMP

The sander has two paper clamps designed to secure standard sandpaper to the platen.

CUSHION

The cushion of the sander accepts both standard and pressure sensitive adhesive sandpaper.

DUST COLLECTION

The sander has a built-in dust collection for maximum comfort and control, longer life, and to help keep the work area clean. A 1-1/4 in. vacuum hose adapter is also provided for attaching to a vacuum cleaner.

ASSEMBLY

UNPACKING

This product has been shipped completely assembled.

- Carefully remove the tool and any accessories from the box. Make sure that all items listed in the packing list are included.
- Inspect the tool carefully to make sure no breakage or damage occurred during shipping.
- Do not discard the packing material until you have carefully inspected and satisfactorily operated the tool.
- If any parts are damaged or missing, please call 1-800-932-3188 for assistance.

PACKING LIST

Sander
Sanding Sheet
Dust Bag
Vacuum Hose Adapter
Operator's Manual

 **WARNING:** If any parts are missing do not operate this tool until the missing parts are replaced. Failure to do so could result in possible serious personal injury.

 **WARNING:** Do not attempt to modify this tool or create accessories not recommended for use with this tool. Any such alteration or modification is misuse and could result in a hazardous condition leading to possible serious personal injury.

 **WARNING:** Do not connect to power supply until assembly is complete. Failure to comply could result in accidental starting and possible serious injury.

OPERATION

 **WARNING:** Do not allow familiarity with tools to make you careless. Remember that a careless fraction of a second is sufficient to inflict serious injury.

 **WARNING:** Always wear safety goggles or safety glasses with side shields when operating power tools. Failure to do so could result in objects being thrown into your eyes resulting in possible serious injury.

APPLICATIONS

You may use this tool for the purposes listed below:

- Sanding on wood surfaces.
- Removing rust from and sanding steel surfaces.

SANDPAPER SELECTION

Selecting the correct size grit and type sandpaper is an extremely important step in achieving a high quality sanded finish. Aluminum oxide, silicon carbide, and other synthetic abrasives are best for power sanding. Natural abrasives such as flint and garnet are too soft for economical use in power sanding.

In general, coarse grit will remove the most material and finer grit will produce the best finish in all sanding operations. The condition of the surface to be sanded will determine which grit will do the job. If the surface is rough, start with a coarse grit and sand until the surface is uniform. Medium grit may then be used to remove scratches

left by the coarser grit and finer grit used for finishing of the surface. Always continue sanding with each grit until surface is uniform.

NOTE: Do not use sander without sandpaper. Doing so will damage the cushion.

INSTALLING SANDPAPER

The cushion on the sander gives you the option of using either non-adhesive sandpaper that clamps to the platen or adhesive backed sandpaper with pressure sensitive adhesive backing that sticks to the cushion.

INSTALLING NON-ADHESIVE SANDPAPER

See Figure 2.

Inspect sandpaper before installing. Do not use if broken or defective.

- Unplug the sander.

NOTE: Removing the dust bag assembly will make installing non-adhesive sandpaper easier. Always remember to replace the dust bag assembly before beginning operation.

- If replacing sandpaper, remove old sandpaper. To remove sandpaper, a lever is located on each side of the sander. Release paper clamps securing sandpaper by lifting up on each lever and disengaging from slot in platen.
- Insert end of new 1/3 sheet sandpaper approximately 1/2 inch under the front paper clamp.

OPERATION

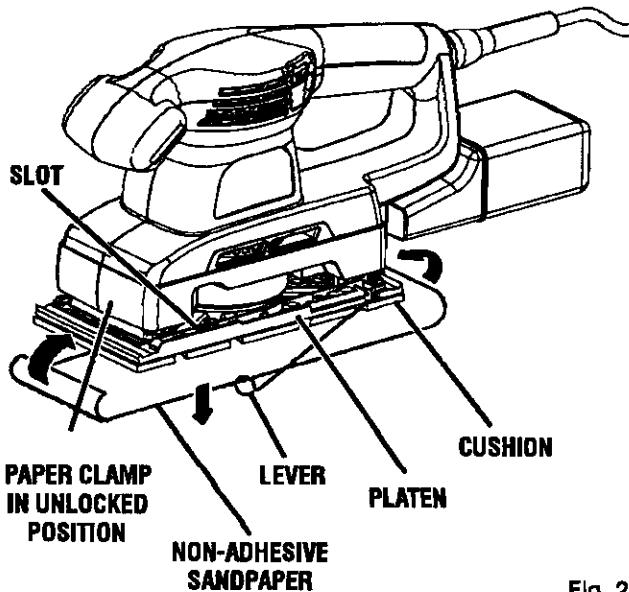

Fig. 2

- Lift up on lever on the left side of sander and lock into slot on platen. Apply downward pressure to conform sandpaper to platen.
- Wrap sandpaper around cushion and insert loose end of sandpaper under the rear paper clamp. Fit sandpaper against cushion as tight as possible.
- Lift up on lever on the right side of sander and lock into slot on platen.

INSTALLING ADHESIVE SANDPAPER

See Figure 3.

- Unplug the sander.

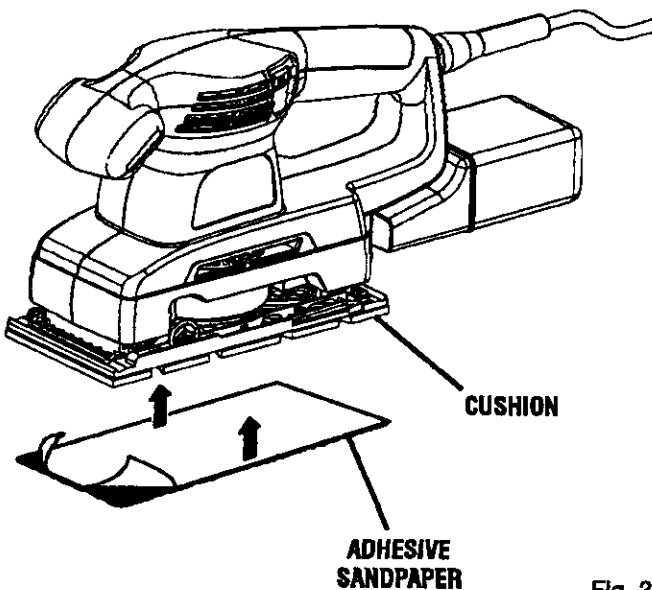

Fig. 3

- If replacing adhesive sandpaper, remove old sandpaper by peeling it off cushion. If removing non-adhesive sandpaper, release paper clamp by lifting up on each lever, then remove sandpaper.
- Place levers back in locked position.

NOTE: Always check to make sure levers are in locked position before turning sander on.

- Carefully peel adhesive backing from new 1/3 sheet sandpaper.
- Position sandpaper, making sure front edge of sandpaper is aligned with front edge of the cushion. Carefully press sticky side of sandpaper on cushion.

NOTE: Sandpaper must be aligned with the front edge of the cushion for proper functioning of the flush sanding feature.

NOTE: It is recommended that you clean the cushion occasionally by brushing lightly with a small brush. Dust build-up on cushion could cause sandpaper to not stick.

INSTALLING DUST BAG ASSEMBLY

See Figure 4.

WARNING: To prevent the possibility of sanding dust or foreign objects being thrown into your face or eyes, never attempt to use the sander without the dust bag assembly properly installed. Sanding dust or foreign objects being thrown into your face could result in possible serious injury.

- Unplug the sander.
- Insert dust bag adapter into dust exhaust.
- Push in on adapter until raised notches on top and bottom of adapter snap into grooves in dust exhaust.
- The sander is now ready for operation.

NOTE: For more efficient operation, empty dust bag when no more than half full. This will permit the air to flow through the bag better. Always empty and clean dust bag thoroughly when finished sanding operation and before storing sander.

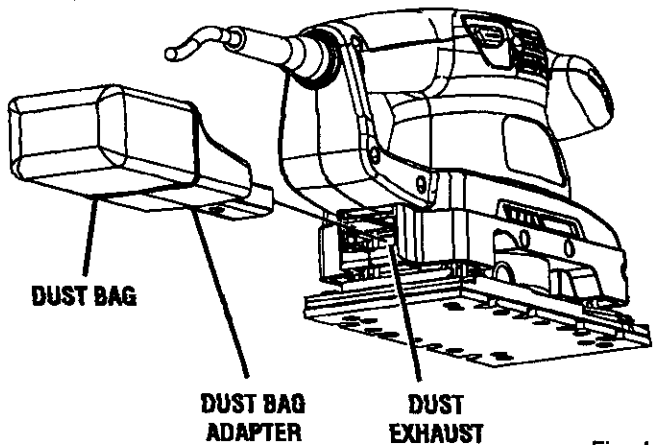

Fig. 4

OPERATION

ATTACHING VACUUM HOSE ADAPTER

See Figure 5.

A 1-1/4 in. vacuum hose adapter is packed with the sander. This adapter easily attaches to the sander if you decide to connect the sander to a vacuum.

TO ATTACH:

- Unplug the sander.
- Remove dust bag assembly from sander. To remove, grasp adapter and pull straight out.
- Insert vacuum hose adapter into dust exhaust.
- Push in on adapter until raised notch on top and bottom of adapter snap into groove in dust exhaust.
- Snugly attach vacuum hose adapter to vacuum hose.
- Connect vacuum hose to cleaner.

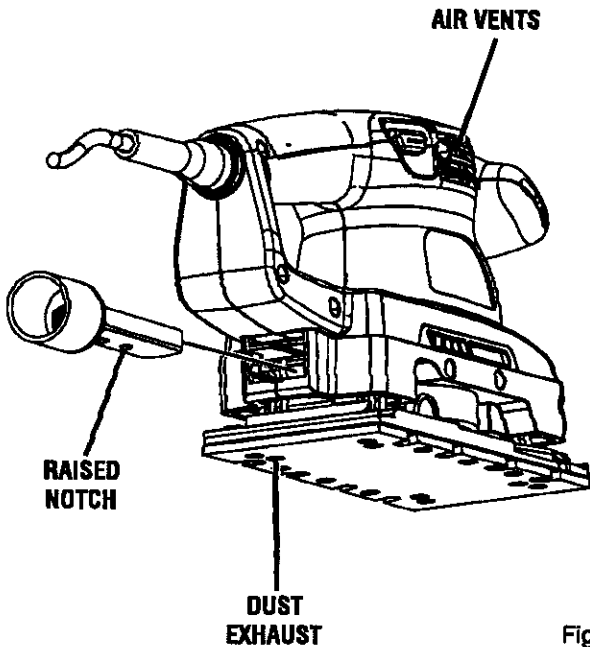

Fig. 5

CAUTION: Be careful not to let your hand cover the air vents.

OPERATING THE SANDER

See Figure 6.

WARNING: Clamp or otherwise secure work to prevent it from moving under the sander. Failure to do so could result in unsecured work being thrown towards the operator resulting in possible serious injury.

Hold the sander in front and away from you, keeping it clear of the workpiece. Start the sander by sliding the switch button to the on position and letting the motor build to its maximum speed. Gradually lower the sander on the work with a slight forward movement. Move it slowly using forward and backward strokes.

Do not force. The weight of the unit supplies adequate pressure, so let the sandpaper and sander do the work. Applying additional pressure only slows the motor, rapidly wears sandpaper and greatly reduces sander speed. Excessive pressure will overload the motor causing possible damage from motor overheating and can result in inferior work. Any finish or resin on wood may soften from the frictional heat. Do not allow sanding on one spot too long as the sander's rapid action may remove too much material, making the surface uneven.

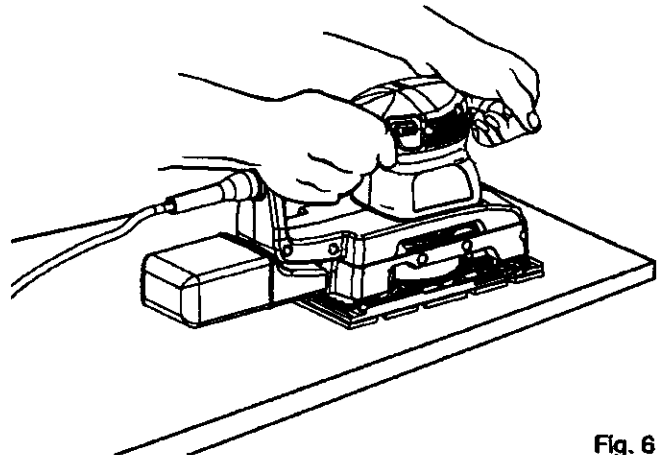

Fig. 6

OPERATION

ORBITAL MOTION

See Figures 7 - 8.

Orbital motion is ideal for fast cutting action when removing old finishes, smoothing rough wood, cutting stock down to required dimensions, or for finishing surfaces to be painted. As shown in figure 8, the sandpaper moves in tiny circles at a very high speed, allowing the sander to move easily.

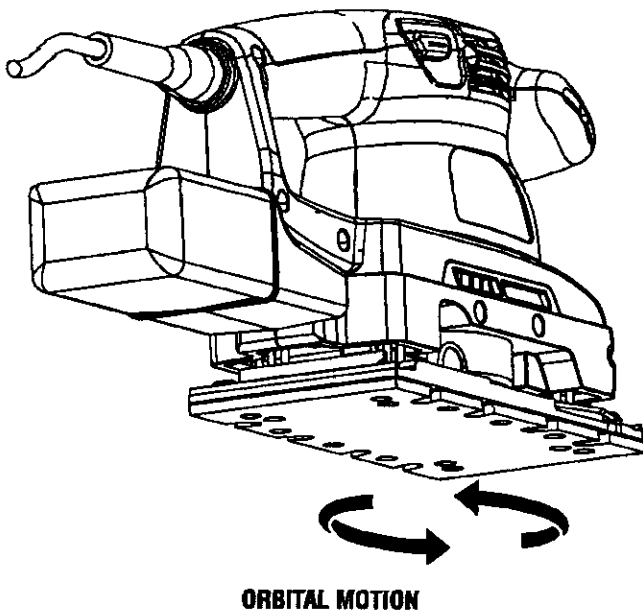

Fig. 7

Flush sanding can be performed with the sander. Every side except the rear of the sander allows flush sanding in corners. Always remove sander from workpiece before turning off.

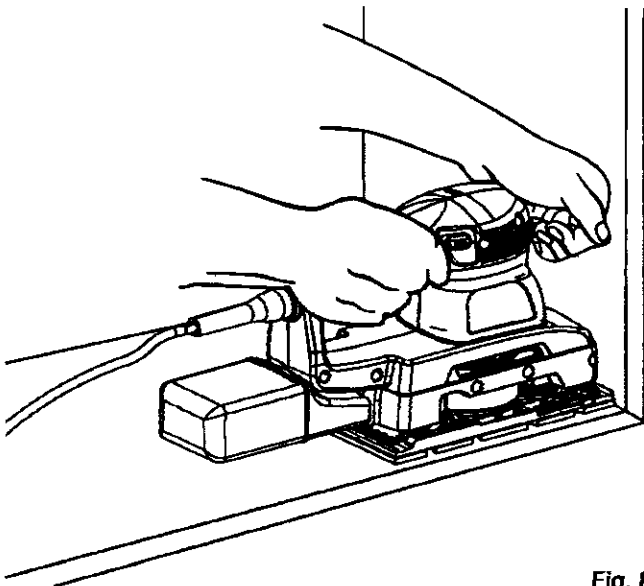

Fig. 8

TO REMOVE AND EMPTY DUST BAG

See Figure 9.

- Unplug the sander.
- Remove dust bag assembly from sander. To remove, grasp adapter and pull straight out.
- Remove dust bag from adapter.
- Shake dust bag to empty.
- Place dust bag back on adapter.
- Attach dust bag assembly back on sander.

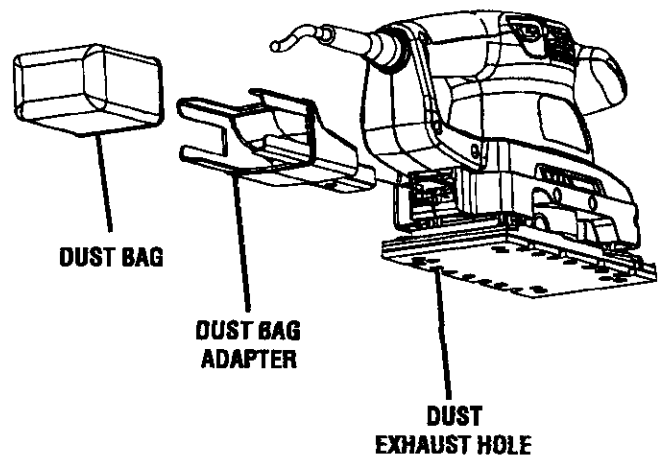

Fig. 9

REMOVING SANDPAPER BEFORE STORAGE

Do not store the sander with pressure sensitive adhesive sandpaper installed. Heat generated from sanding causes the pressure sensitive adhesive to flow and form a tight bond between the cushion and sandpaper.

Removing the sandpaper soon after you have finished a sanding operation avoids letting the adhesive set up. If the sandpaper is left on the cushion for an extended period of time after use, the adhesive will set up and cause the sandpaper to become difficult to remove.

It may also tear when removing. When this situation occurs, it becomes difficult to clean the cushion for the next piece of sandpaper.

NOTE: If you forget to remove the sandpaper after a sanding operation, sand for a few minutes to soften the adhesive backing before attempting to remove sandpaper.

MAINTENANCE

 **WARNING:** When servicing, use only identical Craftsman replacement parts. Use of any other parts may create a hazard or cause product damage.

 **WARNING:** Always wear safety goggles or safety glasses with side shields during power tool operation or when blowing dust. If operation is dusty, also wear a dust mask.

GENERAL MAINTENANCE

Avoid using solvents when cleaning plastic parts. Most plastics are susceptible to damage from various types of commercial solvents and may be damaged by their use. Use clean cloths to remove dirt, dust, oil, grease, etc.

 **WARNING:** Do not at any time let brake fluids, gasoline, petroleum-based products, penetrating oils, etc., come in contact with plastic parts. Chemicals can damage, weaken or destroy plastic which may result in serious personal injury.

Electric tools used on fiberglass material, wallboard, spackling compounds, or plaster are subject to accelerated wear and possible premature failure because the fiberglass chips and grindings are highly abrasive to bearings, brushes, commutators, etc. Consequently, we do not recommend using this tool for extended work on these types of materials. However, if you do work with any of these materials, it is extremely important to clean the tool using compressed air.

LUBRICATION

All of the bearings in this tool are lubricated with a sufficient amount of high grade lubricant for the life of the unit under normal operating conditions. Therefore, no further lubrication is required.

Only the parts shown on the parts list are intended to be repaired or replaced by the customer. All other parts should be replaced at a Sears Service Center.

ACCESSORIES

The following recommended accessories are currently available at Sears retail stores:

- Non-Loading Aluminum Oxide Adhesive Backed Sandpaper 3-2/3 in. x 7-1/8 in.
Extra Fine, Fine, Medium, Coarse
- Aluminum Oxide Sheet Sandpaper 3-2/3 in. x 9 in.
Fine, Medium, Coarse

 **WARNING:** Current attachments and accessories available for use with this tool are listed above. Do not use any attachments or accessories not recommended by the manufacturer of this tool. The use of attachments or accessories not recommended can result in serious personal injury.

CRAFTSMAN SANDER - MODEL NUMBER 315.116920

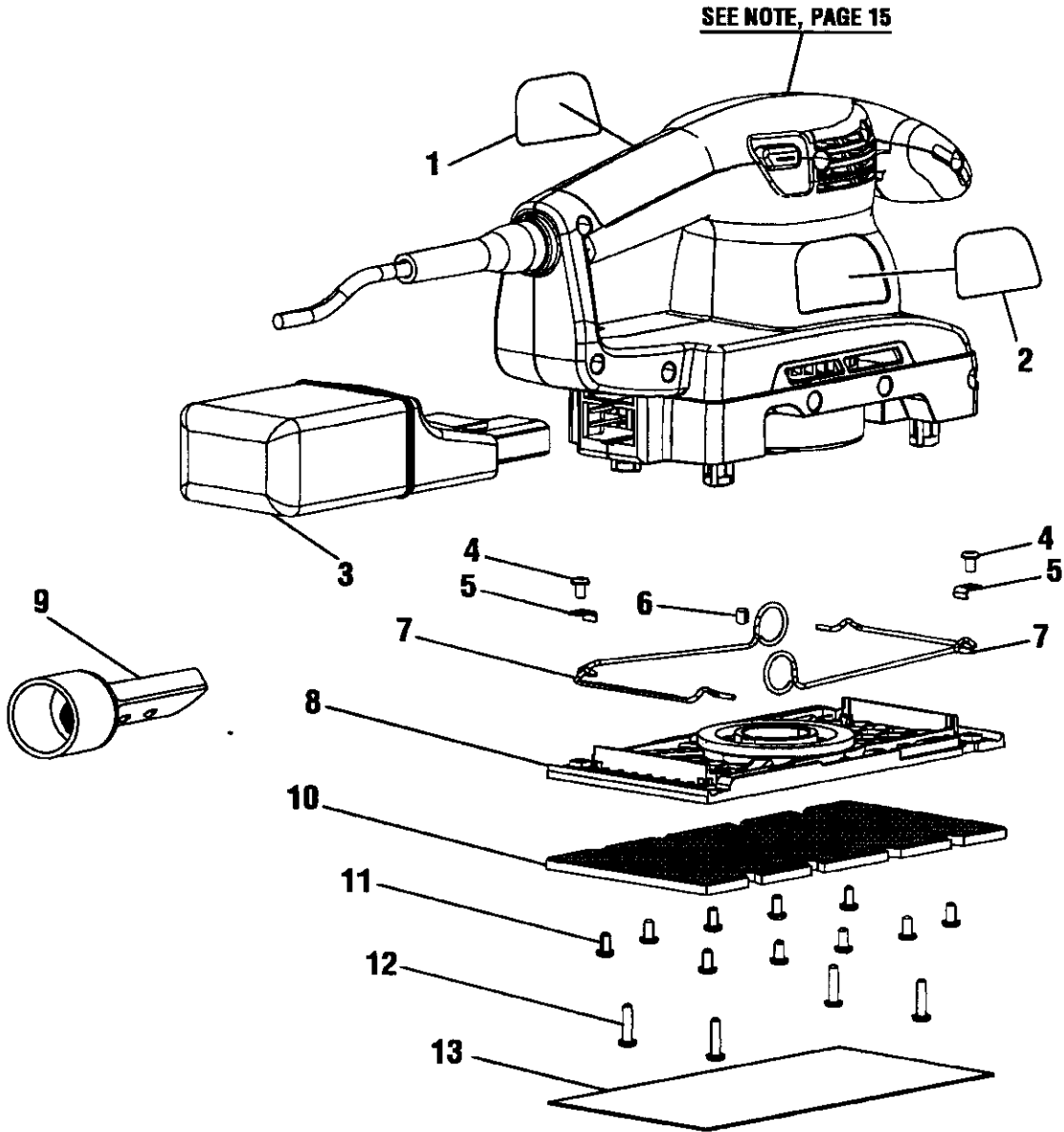

CRAFTSMAN SANDER - MODEL NUMBER 315.116920

The model number will be found on a plate attached to the motor housing. Always mention the model number in all correspondence regarding the SANDER or when ordering repair parts.

SEE BACK PAGE FOR PARTS ORDERING INSTRUCTIONS

PARTS LIST

Key No.	Part Number	Description	Qty.
1	030156001017	Logo Label	1
2	030156001011	Data Label	1
3	030156001018	Dust Bag Assembly	1
	030156001022	Dust Bag	1
4	030155001003	Screw (M4.2 x 8 mm)	2
5	030156001006	Retaining Plate	2
6	030155001007	Rubber Plug	1
7	030156001005	Spring Clamp	2
	030156001001	Platen Assembly (Includes Key Nos. 4-8 and 10-11).....	1
8	030156001004	Platen	1
9	030156001020	Vacuum Hose Adapter	1
10	030156001002	Pad Assembly	1
11	030155001003	Screw (M4.2 x 8 mm)	10
12	030155001002	Screw (M4.2 x 16 mm)	4
13	***	Sandpaper	
	983000-494	Operator's Manual	

NOTE: - The assembly shown represents an important part of the Double Insulated System. To avoid the possibility of alteration or damage to the system, service should be performed by your nearest Sears Repair Center. Contact your nearest Sears Retail Store for Service Center information.

*** Complete assortment available at your Nearest Sears Retail Store

Your Home

For repair – **in your home** – of **all** major brand appliances, lawn and garden equipment, or heating and cooling systems, **no matter who made it, no matter who sold it!**

For the replacement parts, accessories and owner's manuals that you need to do-it-yourself.

For Sears professional installation of home appliances and items like garage door openers and water heaters.

1-800-4-MY-HOME® (1-800-469-4663)

Call anytime, day or night (U.S.A. and Canada)

www.sears.com www.sears.ca

Our Home

For repair of carry-in items like vacuums, lawn equipment, and electronics, call or go on-line for the location of your nearest **Sears Parts & Repair Center.**

1-800-488-1222

Call anytime, day or night (U.S.A. only)

www.sears.com

To purchase a protection agreement (U.S.A.) or maintenance agreement (Canada) on a product serviced by Sears:

1-800-827-6655 (U.S.A.)

1-800-361-6665 (Canada)

Para pedir servicio de reparación a domicilio, y para ordenar piezas:

1-888-SU-HOGARSM

(1-888-784-6427)

Au Canada pour service en français:

1-800-LE-FOYER^{MC}

(1-800-533-6937)

www.sears.ca

SEARS