

Visit www.carrier.com

Installation, Start-Up, and Service Instructions

NOTE: Read the entire instruction manual before starting the installation.

TABLE OF CONTENTS

SAFETY CONSIDERATIONS	1
INTRODUCTION	2
RECEIVING AND INSTALLATION	2
Check Equipment	2
IDENTIFY UNIT	2
INSPECT SHIPMENT	2
Provide Unit Support	2
ROOF CURB	2
SLAB MOUNT	2
GROUND MOUNT	2
Provide Clearances	2
Rig and Place Unit	2
INSPECTION	2
INSTALLATION	2
Select and Install Ductwork	4
CONVERTING HORIZONTAL DISCHARGE UNITS TO DOWNFLOW (VERTICAL) DISCHARGE UNITS	5
Provide for Condensate Disposal	6
Install Electrical Connections	7
HIGH-VOLTAGE CONNECTIONS	10
ROUTING POWER LEADS INTO UNIT	10
CONNECTING GROUND LEAD TO GROUND LUG	10
ROUTING CONTROL POWER WIRES (24-V)	13
SPECIAL PROCEDURES FOR 208-V OPERATION	15
PRE-START-UP	17
START-UP	17
Check for Refrigerant Leaks	17
Start-Up Adjustments	17
CHECKING COOLING AND HEATING CONTROL OPERATION	17
CHECKING AND ADJUSTING REFRIGERANT CHARGE	18
REFRIGERANT CHARGE	18
NO CHARGE	18
LOW CHARGE COOLING	19
TO USE COOLING CHARGING CHARTS	19
INDOOR AIRFLOW AND AIRFLOW ADJUST- MENTS	19
MAINTENANCE	20
Air Filter	21
Indoor blower and motor	21
OUTDOOR COIL, INDOOR COIL, AND CONDENSATE DRAIN PAN	22
Outdoor fan	23
Electrical controls and wiring	23
Refrigerant circuit	24
Indoor airflow	25
Metering device	25
Liquid line strainers	25

High Flow Valves	25
Time-delay relay	25
Loss of charge switch	25
Check defrost thermostat	25
Defrost Thermostat	25
TROUBLESHOOTING	25
START-UP CHECKLIST	25

NOTE TO INSTALLER — READ THESE INSTRUCTIONS CAREFULLY AND COMPLETELY before installing this unit. Also, make sure the Owner's Manual and Service Instructions are left with the unit after installation.

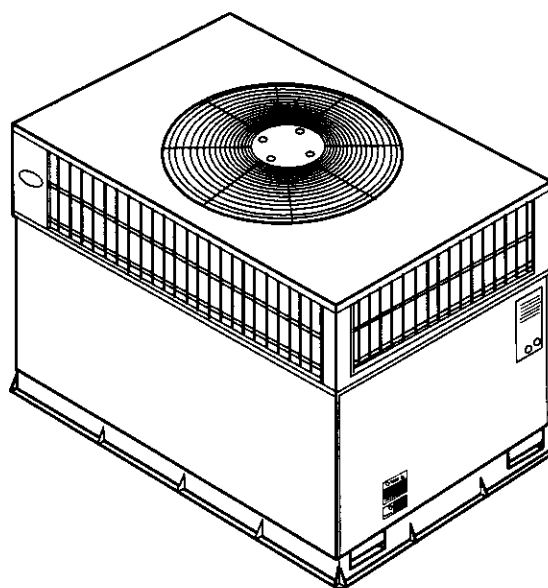

C99001

Fig. 1—Model 50JS/50JX

SAFETY CONSIDERATIONS

Installation and servicing of air-conditioning equipment can be hazardous due to system pressure and electrical components. Only trained and qualified personnel should install, repair, or service air-conditioning equipment.

Untrained personnel can perform basic maintenance functions of cleaning coils and filters. All other operations should be performed by trained service personnel. When working on air-conditioning equipment, observe precautions in the literature, tags, and labels attached to the unit, and other safety precautions that may apply.

Follow all safety codes. Wear safety glasses and work gloves. Use quenching cloth for unbrazing operations. Have fire extinguisher available for all brazing operations.

Manufacturer reserves the right to discontinue, or change at any time, specifications or designs without notice and without incurring obligations.

⚠ WARNING

Improper installation, adjustment, alteration, service, maintenance, or use can cause explosion, fire, electric shock, or other occurrences, which could cause serious injury or death or damage your property. Consult a qualified installer or service agency for information or assistance. The qualified installer or agency must use only factory-authorized kits or accessories when modifying this product.

Recognize safety information. This is the safety-alert symbol ⚠. When you see this symbol on the product or in instructions or manuals, be alert to the potential for personal injury.

Understand the signal words — DANGER, WARNING, CAUTION, and NOTE. Danger identifies the most serious hazards, which **will** result in severe personal injury or death. Warning indicates a condition that **could** cause serious personal injury or death. Caution is used to identify unsafe practices, which **would** result in minor personal injury or product and property damage. NOTE is used to highlight suggestions which **will** result in enhanced installation, reliability, or operation.

1. The power supply (volts, phase, and hertz) must correspond to that specified on unit rating plate.
2. The electrical supply provided by the utility must be sufficient to handle load imposed by this unit.
3. This installation must conform with local building codes and with NEC (National Electrical Code). Refer to provincial and local plumbing or waste water codes and other applicable local codes.

⚠ WARNING

Before performing service or maintenance operations on system, turn off main power to unit. Turn off accessory heater power switch if applicable. Electrical shock could cause severe injury or death.

INTRODUCTION

The 50JS and 50JX heat pumps are fully self-contained and designed for outdoor installation (See Fig. 1). Standard units are shipped in a horizontal-discharge configuration for installation on a ground-level slab. Units can be converted to downflow (vertical) discharge configurations for rooftop applications.

RECEIVING AND INSTALLATION

Step 1—Check Equipment

IDENTIFY UNIT

The unit model number and serial number are stamped on the unit identification plate. Check this information against shipping papers.

INSPECT SHIPMENT

Inspect for shipping damage while unit is still on shipping pallet. If unit appears to be damaged or is torn loose from its anchorage, have it examined by transportation inspectors before removal. Forward claim papers directly to transportation company. Manufacturer is not responsible for any damage incurred in transit. Check all items against shipping list. Immediately notify the nearest Carrier Air Conditioning office if any item is missing. To prevent loss or damage, leave all parts in original packages until installation.

Step 2—Provide Unit Support

ROOF CURB

Install accessory roof curb in accordance with instructions shipped with curb (See Fig. 5). Install insulation, cant strips, roofing, and flashing. Ductwork must be attached to curb.

IMPORTANT: The gasketing of the unit to the roof curb is critical for a watertight seal. Install gasketing material supplied with the roof curb. Improperly applied gasketing also can result in air leaks and poor unit performance.

Curb should be level to within 1/4 in. (See Fig. 6). This is necessary for unit drain to function properly. Refer to accessory roof curb installation instructions for additional information as required.

SLAB MOUNT

Place the unit on a solid, level concrete pad that is a minimum of 4 in. thick with 2 in. above grade (See Fig. 7). The slab should extend approximately 2 in. beyond the casing on all 4 sides of the unit. Do not secure the unit to the slab *except* when required by local codes.

GROUND MOUNT

The unit may be installed either on a slab or placed directly on the ground if local codes permit. Place the unit on level ground prepared with gravel for condensate discharge.

Step 3—Provide Clearances

The required minimum service clearances are shown in Figs. 2 and 3. Adequate ventilation and outdoor air must be provided. The outdoor fan draws air through the outdoor coil and discharges it through the top fan grille. Be sure that the fan discharge does not recirculate to the outdoor coil. Do not locate the unit in either a corner or under an overhead obstruction. The minimum clearance under a partial overhang (such as a normal house overhang) is 36 in. above the unit top. The maximum horizontal extension of a partial overhang must not exceed 48 in. For extended overhangs, provide a minimum clearance of 48 in.

IMPORTANT: Do not restrict outdoor airflow. An air restriction at either the outdoor-air inlet or the fan discharge may be detrimental to compressor life.

Do not place the unit where water, ice, or snow from an overhang or roof will damage or flood the unit. Do not install the unit on carpeting or other combustible materials. Slab-mounted units should be at least 4 in. above the highest expected water and runoff levels. Do not use unit if it has been under water.

Step 4—Rig and Place Unit

Rigging and handling of this equipment can be hazardous for many reasons due to the installation location (roofs, elevated structures, etc.)

Only trained, qualified crane operators and ground support staff should handle and install this equipment.

When working with this equipment, observe precautions in the literature, on tags, stickers, and labels attached to the equipment, and any other safety precautions that might apply.

Follow all applicable safety codes. Wear safety shoes and work gloves.

INSPECTION

Prior to initial use, and at monthly intervals, all rigging brackets and straps should be visually inspected for any damage, evidence of wear, structural deformation, or cracks. Particular attention should be paid to excessive wear at hoist hooking points and load support areas. Brackets or straps showing any kind of wear in these areas must not be used and should be discarded.

INSTALLATION

1. Remove unit from shipping carton. Leave top shipping skid on the unit as a spreader bar to prevent the rigging straps from damaging the unit. If the wood skid is not available, use a spreader bar of sufficient length to protect unit from damage.

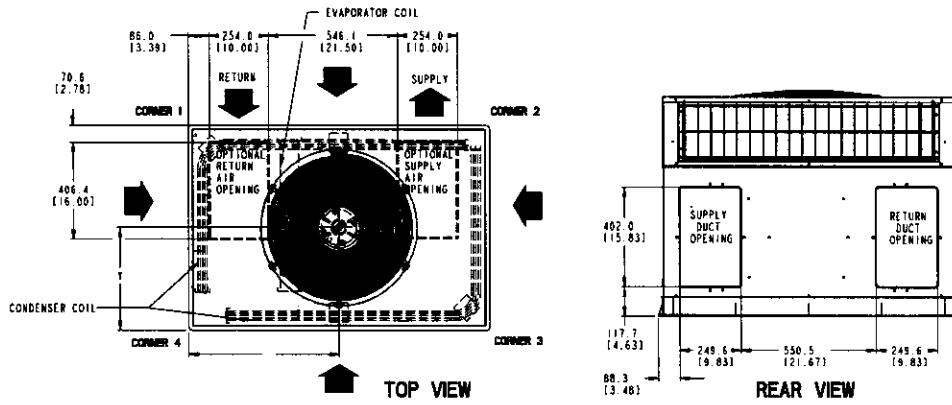

REQUIRED CLEARANCES TO COMBUSTIBLE MATL.

	MILLIMETERS (IN)
TOP OF UNIT.....	355.6 (14.00)
DUCT SIDE OF UNIT.....	50.8 (2.00)
SIDE OPPOSITE DUCTS.....	355.6 (14.00)
BOTTOM OF UNIT.....	12.7 (0.50)
ELECTRIC HEAT PANEL.....	914.4 (36.00)

NEC REQUIRED CLEARANCES

	MILLIMETERS (IN)
BETWEEN UNITS, POWER ENTRY SIDE.....	1066.8 (42.00)
UNIT AND UNGROUNDED SURFACES, POWER ENTRY SIDE.....	914.0 (36.00)
UNIT AND BLOCK OR CONCRETE WALLS AND OTHER GROUNDED SURFACES, POWER ENTRY SIDE.....	1066.8 (42.00)

REQUIRED CLEARANCE FOR OPERATION AND SERVICING

	MILLIMETERS (IN)
EVAP. COIL ACCESS SIDE.....	914.0 (36.00)
POWER ENTRY SIDE.....	914.0 (36.00)
(EXCEPT FOR NEC REQUIREMENTS)	
UNIT TOP.....	914.0 (36.00)
SIDE OPPOSITE DUCTS.....	914.0 (36.00)
DUCT PANEL.....	304.8 (12.00)

*MINIMUM DISTANCES: IF UNIT IS PLACED LESS THAN 304.8 (12.00) FROM WALL SYSTEM, THEN SYSTEM PERFORMANCE MAYBE COMPROMISED.

DIMENSIONS IN [] ARE IN INCHES

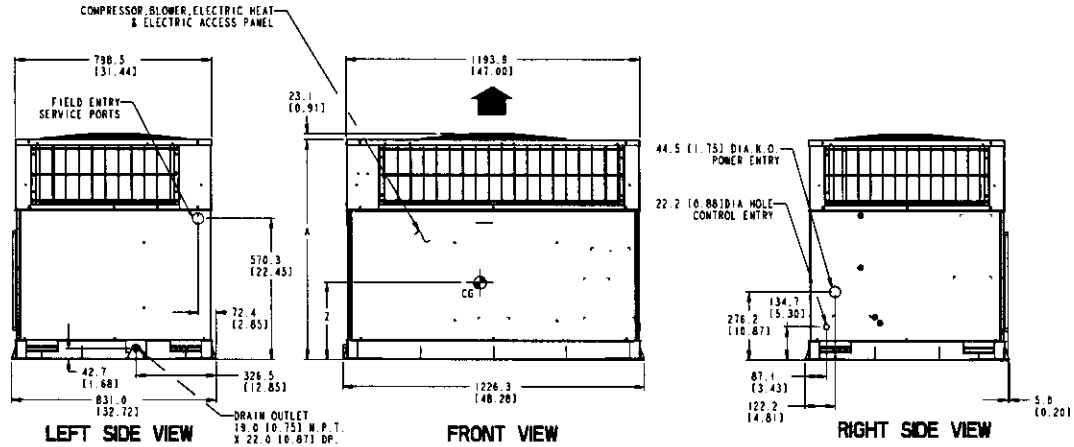

C00137

UNIT	ELECTRICAL CHARACTERISTICS	UNIT WEIGHT		UNIT HEIGHT IN. (MM) "A"	CENTER OF GRAVITY IN. (MM)		
		lb	kg		X	Y	Z
50JS018	208/230-1-60	283	128.4	37.02 (940.3)	19.5 (495.3)	13.7 (348.0)	15.0 (381.0)
50JS024	208/230-1-60	289	131.1	39.02 (991.1)	19.7 (500.4)	13.9 (353.1)	15.0 (381.0)
50JS030	208/230-1-60, 208/230-3-60	287	130.2	39.02 (991.1)	19.5 (495.3)	13.7 (348.0)	15.0 (381.0)
50JS036	208/230-1-60, 208/230-3-60, 460-3-60	291	132.0	37.02 (940.3)	19.5 (495.3)	13.7 (348.0)	13.0 (330.2)
50JS042	208/230-1-60, 208/230-3-60, 460-3-60	323	146.5	37.02 (940.3)	19.7 (500.4)	14.0 (355.6)	13.0 (330.2)
50JX024	208/230-1-60	299	135.6	41.02 (1041.9)	19.0 (482.6)	13.7 (348.0)	16.0 (406.4)
50JX030	208/230-1-60, 208/230-3-60	320	145.2	37.02 (940.3)	19.7 (500.4)	14.0 (355.6)	17.6 (447.0)
50JX036	208/230-1-60, 208/230-3-60, 460-3-60	328	148.8	37.02 (940.3)	19.7 (500.4)	14.0 (355.6)	16.5 (419.1)

Fig. 2—50JS018-042/50JX024-036 Unit Dimensions

- Position the lifting bracket assembly around the base of the unit. Be sure the strap does not twist.
- Place each of the 4 metal lifting brackets into the rigging holds in the composite pan.
- Thread lifting bracket strapping around bottom perimeter of unit as follows:
 - Open lever of tension buckle (ratchet type).
 - Feed strapping through tension buckle as shown in Fig. 8.
 - Pull strapping through tension buckle unit taut.
 - Snap lever down to lock strap in tension buckle. To release strapping, squeeze safety latch, lift lever, and pull webbing outward.
- Tighten the tension buckle until it is taut. Lifting brackets must be secure in the rigging holds.
- Attach field-supplied clevis or hook of sufficient strength to hole in the lifting bracket (See Fig. 9).
- Attach the 2 safety straps directly to the clevis or hook at the 4 rigging brackets. **DO NOT** attach the safety straps to the lifting brackets (See Fig. 9).

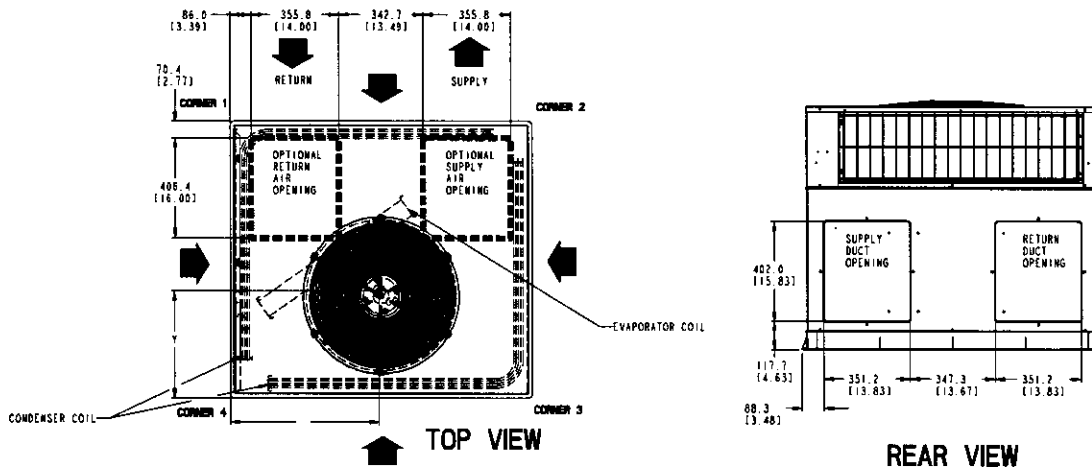

REQUIRED CLEARANCES TO COMBUSTIBLE MATL.

	MILLIMETERS (IN)
TOP OF UNIT	355.8 (14.00)
DUCT SIDE OF UNIT	50.8 (2.00)
SIDE OPPOSITE DUCTS	355.6 (14.00)
BOTTOM OF UNIT	12.7 (0.50)
ELECTRIC HEAT PANEL	914.4 (36.00)

NEC REQUIRED CLEARANCES

	MILLIMETERS (IN)
BETWEEN UNITS, POWER ENTRY SIDE	1066.8 (42.00)
UNIT AND UNGROUNDED SURFACES, POWER ENTRY SIDE	914.0 (36.00)
UNIT AND BLOCK OR CONCRETE WALLS AND OTHER GROUNDED SURFACES, POWER ENTRY SIDE	1066.8 (42.00)

REQUIRED CLEARANCE FOR OPERATION AND SERVICING

	MILLIMETERS (IN)
EVAP. COIL ACCESS SIDE	914.0 (36.00)
POWER ENTRY SIDE (EXCEPT FOR NEC REQUIREMENTS)	914.0 (36.00)
UNIT TOP	914.0 (36.00)
SIDE OPPOSITE DUCTS	914.0 (36.00)
DUCT PANEL	304.8 (12.00)

*MINIMUM DISTANCES: IF UNIT IS PLACED LESS THAN 304.8 (12.00) FROM WALL SYSTEM, THEN SYSTEM PERFORMANCE MAYBE COMPROMISED.

DIMENSIONS IN () ARE IN INCHES

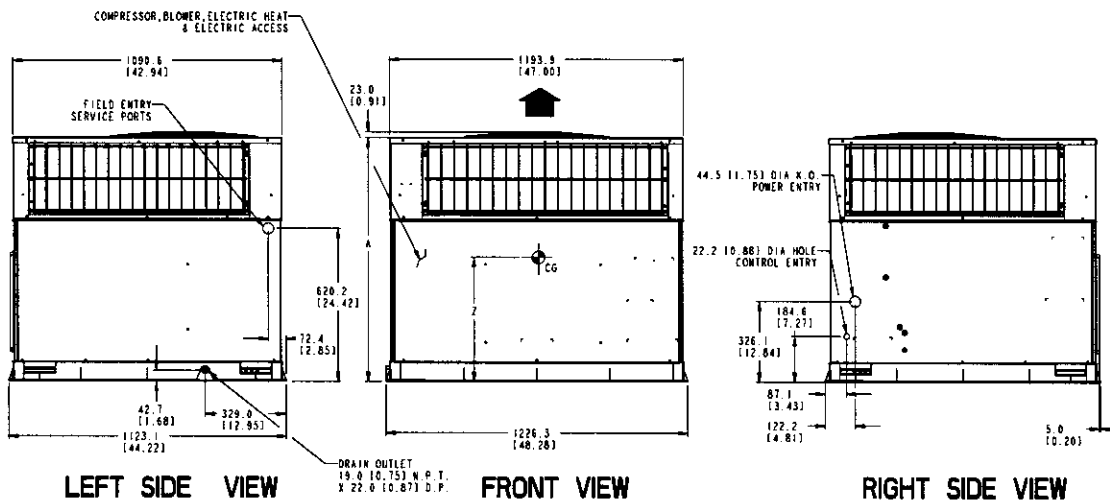

C00136

UNIT	ELECTRICAL CHARACTERISTICS	UNIT WEIGHT		UNIT HEIGHT IN. (MM) "A"	CENTER OF GRAVITY IN. (MM)		
		lb	kg		X	Y	Z
50JS048	208/230-1-60, 208/230-3-60, 460-3-60	353	160.1	38.98 (990.2)	19.9 (505.5)	15.7 (398.8)	17.0 (431.8)
50JS060	208/230-1-60, 208/230-3-60, 460-3-60	418	189.6	38.98 (990.2)	19.9 (505.5)	15.7 (398.8)	17.0 (431.8)
50JX042	208/230-1-60, 208/230-3-60, 460-3-60	350	158.8	40.98 (1040.9)	19.9 (505.5)	15.7 (398.8)	16.6 (421.6)
50JX048	208/230-1-60, 208/230-3-60, 460-3-60	315	170.1	40.98 (1040.9)	19.9 (505.5)	15.7 (398.8)	18.0 (457.2)
50JX060	208/230-1-60, 208/230-3-60, 460-3-60	428	194.1	42.98 (1091.7)	19.9 (505.5)	15.7 (398.8)	17.6 (447.0)

Fig. 3—50JS048-060/50JX042-060 Unit Dimensions

- Position lifting point directly over the unit's center of gravity.
- Lift unit. When unit is directly over the roof curb, remove the 2 safety straps. Lower the equipment onto the roof curb.

Step 5—Select and Install Ductwork

The design and installation of the duct system must be in accordance with the standards of the NFPA for installation of non-residence type air conditioning and ventilating systems, NFPA 90A or residence type, NFPA 90B and/or local codes and ordinances.

Select and size ductwork, supply-air registers, and return air grilles according to ASHRAE (American Society of Heating, Refrigeration, and Air Conditioning Engineers) recommendations.

The unit has duct flanges on the supply- and return-air openings on the side of the unit.

When designing and installing ductwork, consider the following:

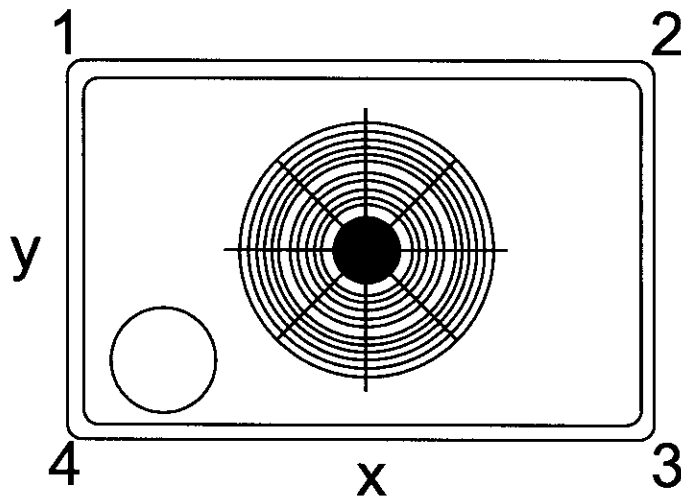

C00071

CORNER WEIGHTS (SMALL CABINET)						CORNER WEIGHTS (LARGE CABINET)					
Model 50JS	Unit	18	24	30	36	42	Model 50JS	Unit	48	60	—
	Total Weight	283	289	287	291	323		Total Weight	353	418	—
	Comer Weight 1	65	67	66	67	83		Comer Weight 1	76	90	—
	Comer Weight 2	53	56	54	55	55		Comer Weight 2	49	58	—
	Comer Weight 3	61	62	62	63	78		Comer Weight 3	96	114	—
	Comer Weight 4	103	104	105	106	107		Comer Weight 4	132	156	—
CORNER WEIGHTS (Small Cabinet)						CORNER WEIGHTS (Large Cabinet)					
Model 50JX	Unit	24	30	36	—	—	Model 50JX	Unit	42	48	60
	Total Weight	299	320	328	—	—		Total Weight	350	375	428
	Comer Weight 1	63	63	64	—	—		Comer Weight 1	75	81	92
	Comer Weight 2	62	74	76	—	—		Comer Weight 2	49	52	60
	Comer Weight 3	56	56	58	—	—		Comer Weight 3	95	102	116
	Comer Weight 4	118	127	130	—	—		Comer Weight 4	131	140	160

Fig. 4—Corner Weights (in Pounds)

▲ WARNING

For vertical supply and return units, tools or parts could drop into ductwork and cause serious injury or death. Install a 90 degree turn in the return ductwork between the unit and the conditioned space. If a 90 degree elbow cannot be installed, then a grille of sufficient strength and density should be installed to prevent objects from falling into the conditioned space. Units with electric heaters require 90 degree elbow in supply duct.

1. All units should have field-supplied filters or accessory filter rack installed in the return-air side of the unit. Recommended sizes for filters are shown in Tables 1 and 2.
2. Avoid abrupt duct size increases and reductions. Abrupt change in duct size adversely affects air performance.

IMPORTANT: Use flexible connectors between ductwork and unit to prevent transmission of vibration. Use suitable gaskets to ensure weather tight and airtight seal. When electric heat is installed, use fireproof canvas (or similar heat resistant material) connector between ductwork and unit discharge connection. If flexible duct is used, insert a sheet metal sleeve inside duct. Heat resistant duct connector (or sheet metal sleeve) must extend 24-in. from electric heater element.

3. Size ductwork for cooling air quantity (cfm). The minimum air quantity for proper electric heater operation is listed in Tables 3 and 4. Heater limit switches may trip at air quantities below those recommended.

4. Seal, insulate, and weatherproof all external ductwork. Seal, insulate and cover with a vapor barrier all ductwork passing through conditioned spaces. Follow latest Sheet Metal and Air Conditioning Contractors National Association (SMACNA) and Air Conditioning Contractors Association (ACCA) minimum installation standards for residential heating and air conditioning systems.
5. Secure all ducts to building structure. Flash, weatherproof, and vibration-isolate duct openings in wall or roof according to good construction practices.

CONVERTING HORIZONTAL DISCHARGE UNITS TO DOWNFLOW (VERTICAL) DISCHARGE UNITS

▲ WARNING

Before performing service or maintenance operations on system, turn off main power to unit and install lockout tag. Turn off accessory heater power switch if applicable. Electrical shock could cause serious injury or death.

1. Open all electrical disconnects and install lockout tag before starting any service work.
2. Remove side duct covers to access bottom return and supply knock outs.

NOTE: These panels are held in place with tabs similar to an electrical knockout.

3. Use a screwdriver and hammer to remove the panels in the bottom of the composite unit base.

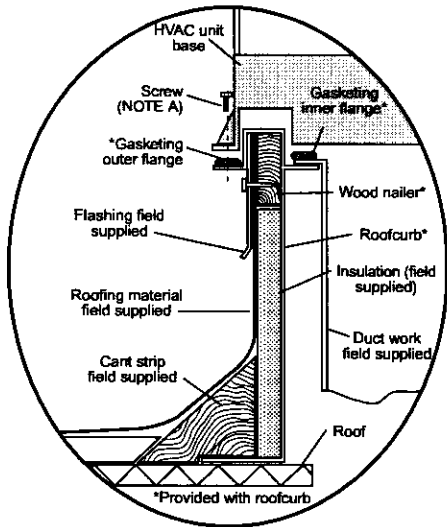

Roof Curb for Small Cabinet

Note A: When unit mounting screw is used, retainer bracket must also be used.

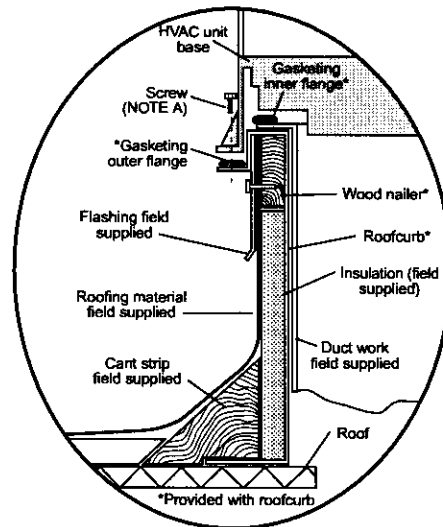

Roof Curb for Large Cabinet

Note A: When unit mounting screw is used, retainer bracket must also be used.

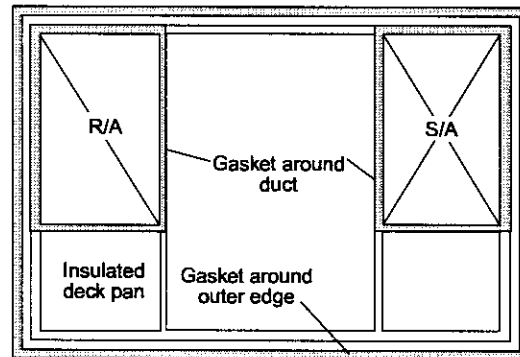
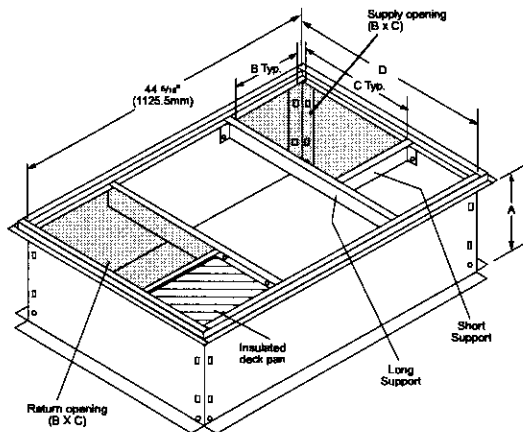

C00076

UNIT SIZE		ODS CATALOG NUMBER	A IN. (MM)	B IN. (MM)	C IN. (MM)	D IN. (MM)
50JS018-042	50JX024-036	CPRFCURB006A00	8 (203)	11(279)	161/2 (419)	28-3/4 (730)
		CPRFCURB007A00	14 (356)	11(279)	161/2 (419)	28-3/4 (730)
50JS048-060	50JX042-060	CPRFCURB008A00	8 (203)	16 3/16 (411)	17 3/8 (441)	40-1/4 (1022)
		CPRFCURB009A00	14 (356)	16 3/16 (411)	17 3/8 (441)	40-1/4 (1022)

NOTES:

1. Roof curb must be set up for unit being installed.
2. Seal strip must be applied, as required, to unit being installed.
3. Dimensions in () are in millimeters.
4. Roof curb is made of 16-gage steel.
5. Table lists only the dimensions, per part number, that have changed.
6. Attach ductwork to curb (flanges of duct rest on curb).
7. Insulated panels: 1-in. thick fiberglass 1 lb density.
8. Dimensions are in inches.
9. When unit mounting screw is used (see Note A), a retainer bracket must be used as well. This bracket must also be used when required by code for hurricane or seismic conditions. This bracket is available through Micromet.

Fig. 5—Roof Curb Dimensions

4. Ensure the side duct covers are in place to block off the horizontal air openings.

NOTE: Avoid abrupt duct size increases and reductions. Abrupt change in duct size adversely affects air performance.

Step 6—Provide for Condensate Disposal

NOTE: Ensure that condensate-water disposal methods comply with local codes, restrictions, and practices.

The units dispose of condensate through a 3/4 in. NPT female fitting that exits on the compressor end of the unit. Condensate water can be drained directly onto the roof in rooftop installations (where permitted) or onto a gravel apron in ground level installations. Install a field-supplied condensate trap at end of condensate connection to ensure proper drainage. Make sure that the outlet of the trap is at least 1 in. lower than the drain-pan condensate

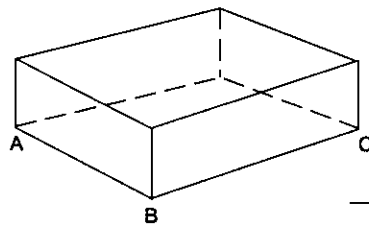

MAXIMUM ALLOWABLE DIFFERENCE (in.)		
A-B	B-C	A-C
1/4	1/4	1/4

Fig. 6—Unit Leveling Tolerances

C99065

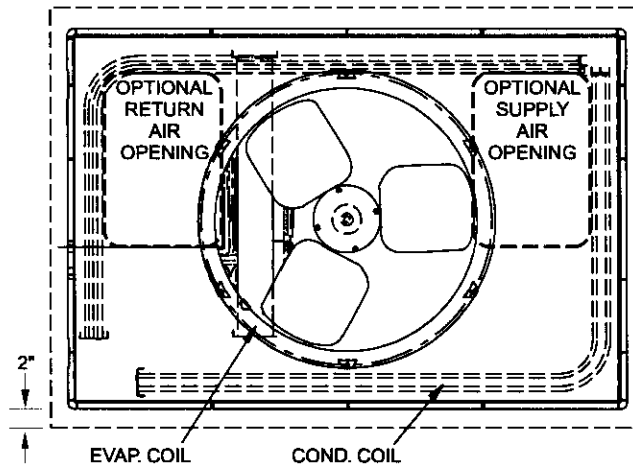

Fig. 7—Slab Mounting Detail

C99096

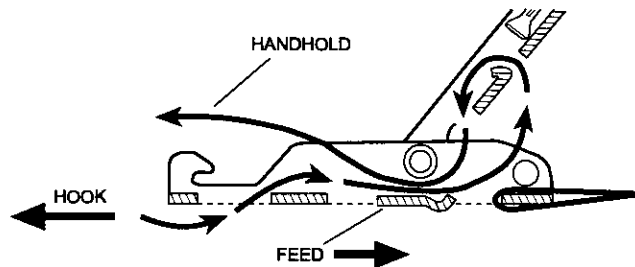

Fig. 8—Threading Belt

C99067

connection to prevent the pan from overflowing. Prime the trap with water. When using a gravel apron, make sure it slopes away from the unit.

If the installation requires draining the condensate water away from the unit, install a field-supplied 2-in. trap at the condensate connection to ensure proper drainage. Condensate trap is available as an accessory or is field-supplied. Make sure that the outlet of the trap is at least 1 in. lower than the unit drain-pan condensate connection to prevent the pan from overflowing. Connect a drain trough using a minimum of field-supplied 3/4 -in. PVC or field-supplied 3/4 -in. copper pipe at outlet end of the 2 -in. trap (See Fig. 12). Do not undersize the tube. Pitch the drain trough downward at a slope of at least 1 in. every 10 ft. of horizontal run. Be sure to check the drain trough for leaks. Prime the trap at the beginning of the cooling season start-up.

Step 7—Install Electrical Connections

⚠ WARNING

The unit cabinet must have an uninterrupted, unbroken electrical ground to minimize the possibility of personal injury if an electrical fault should occur. This ground may consist of an electrical wire connected to the unit ground lug in the control compartment, or conduit approved for electrical ground when installed in accordance with NEC, ANSI/NFPA American National Standards Institute/National Fire Protection Association (latest edition) (in Canada, Canadian Electrical Code CSA C22.1) and local electrical codes. Failure to adhere to this warning could result in serious injury or death.

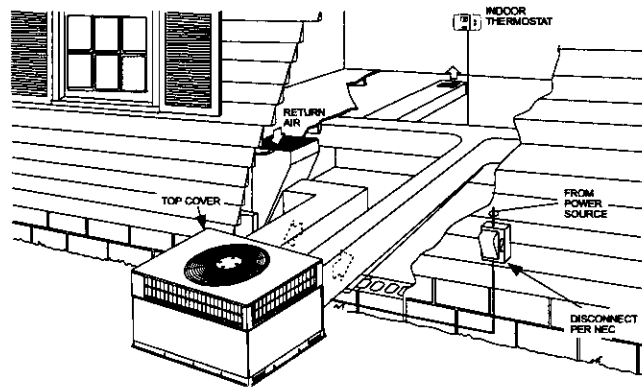

C00139

Fig. 10—Typical Installation

Table 1—Physical Data

UNIT SIZE	50JS018	50JS024	50JS030	50JS036	50JS042	50JS048	50JS060
NOMINAL CAPACITY (ton)	1-1/2	2	2-1/2	3	3-1/2	4	5
OPERATING WEIGHT (lb.)	283	289	287	291	323	353	418
COMPRESSOR QUANTITY	1						
TYPE	RECIPROCATING COMPRESSOR				SCROLL COMPRESSOR		
REFRIGERANT	R-22						
REFRIGERANT METERING DEVICE	AccuRater®						
Refrigerant (R-22) Quantity (lb.)	6.5	5.3	5.6	7.6	8.0	7.85	9.3
ORIFICE ID (in.)	0.053	0.061	0.068	0.078	0.078	0.088	0.093
ORIFICE OD (in.)	0.040	0.035 (2)	0.042 (2)	0.046 (2)	0.052 (2)	0.057 (2)	0.061 (2)
OUTDOOR COIL Rows... Fins/in. Face Area (sq. ft.)	1...17 10.2	1...17 12.0	1...17 12.0	2...17 10.3	2...17 10.3	2...17 11.6	2...17 11.6
OUTDOOR FAN Nominal Airflow (CFM) Diameter Motor HP (RPM)	2400 22 1/8 (825)	2400 22 1/8 (825)	2400 22 1/8 (825)	2800 22 1/4 (1100)	2400 22 1/8 (825)	3300 22 1/4 (1100)	3300 22 1/4 (1100)
INDOOR COIL Rows... Fins/in. Face Area (sq. ft.)	2...15 3.7	2...15 3.7	3...15 3.7	3...15 3.7	4...15 3.7	3...15 4.7	4...15 4.7
INDOOR BLOWER Nominal Airflow (CFM) Size (in.) Motor HP (RPM)	700 10X10 1/8 (1075)	800 10X10 1/4 (1075)	1000 10X10 1/4 (1075)	1200 11X10 1/2 (1075)	1250 11X10 3/4 (1075)	1600 11X10 3/4 (1075)	2000 11X10 1 (1100)
RETURN-AIR FILTERS (in.) throwaway	20X20X1	20X20X1	20X20X1	20X24X1	24X30X1	24X30X1	24X30X1

Table 2—Physical Data

UNIT SIZE	50JX024	50JX030	50JX036	50JX042	50JX048	50JX060
NOMINAL CAPACITY (ton)	2	2-1/2	3	3-1/2	4	5
OPERATING WEIGHT (lb.)	299	320	328	350	375	428
COMPRESSOR QUANTITY	1					
TYPE	SCROLL COMPRESSOR					
REFRIGERANT	R-22					
REFRIGERANT METERING DEVICE	AccuRater®					
Refrigerant (R-22) Quantity (lb.)	5.1	6.4	7.0	10.8	10.1	12.3
ORIFICE ID (in.)	0.065	0.073	0.076	0.080	0.088	0.093
ORIFICE OD (in.)	0.037 (2)	0.043 (2)	0.040 (2)	0.052 (2)	0.057 (2)	0.063 (2)
OUTDOOR COIL Rows... Fins/in. Face Area (sq. ft.)	1...17 13.7	2...17 10.3	2...17 10.3	2...17 13.7	2...17 13.7	2...17 15.7
OUTDOOR FAN Nominal Airflow (CFM) Diameter Motor HP (RPM)	2350 22 1/8 (825)	2350 22 1/8 (825)	2800 22 1/4 (1100)	2800 22 1/8 (825)	3300 22 1/4 (1100)	3300 22 1/4 (1100)
INDOOR COIL Rows... Fins/in. Face Area (sq. ft.)	3...15 3.7	3...15 3.7	4...15 3.7	4...15 4.7	4...15 4.7	4...15 5.7
INDOOR BLOWER Nominal Airflow (CFM) Size (in.) Motor HP (RPM)	800 10X10 1/4 (1075)	1000 10X10 1/4 (1075)	1200 10X10 1/2 (1075)	1400 11X10 1/2 (1075)	1450 11X10 1/2 (1075)	1750 11X10 1 (1040)
RETURN-AIR FILTERS (in.) throwaway	20X20X1	20X20X1	20X24X1	24X30X1	24X30X1	24X30X1

NOTE: Air filter pressure drop for non-standard filters must not exceed 0.08 in. wg.

Table 3—Minimum Airflow for Reliable Electric Heater Operation (Cfm)

SIZE	50JS018	50JS024	50JS030	50JS036	50JS042	50JS048	50JS060
AIRFLOW (CFM)	650	800	1000*	1200	1400	1600	2000

* The 030 size models must be run on medium or high speed when used in conjunction with 15 kw electric heat accessory

Table 4—Minimum Airflow for Reliable Electric Heater Operation (Cfm)

SIZE	50JX024	50JX030	50JX036	50JX042	50JX048	50JX060
AIRFLOW (CFM)	800	1000*	1200	1400	1600	2000

* The 030 size models must be run on medium or high speed when used in conjunction with 15 kw electric heat accessory

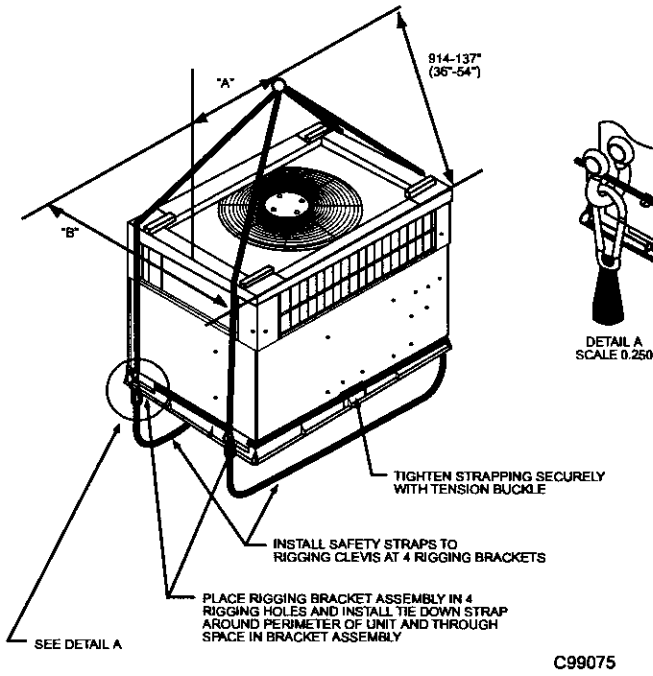

UNIT	MAXIMUM WEIGHT (INCLUDES SHIPPING SKID)		A		B	
	lb	kg	in.	mm.	in.	mm.
50JS018	305	138.4	19.5	495.3	16.75	425.5
50JS024	311	141.1	18.5	469.9	16.75	425.5
50JS030	309	140.2	19.5	495.3	17.50	444.5
50JS036	313	142.0	19.5	495.3	17.75	450.9
50JS042	345	156.4	19.5	495.3	17.75	450.9
50JS048	375	170.1	20.5	520.7	20.62	523.8
50JS060	440	199.6	19.5	495.3	19.75	501.7
50JX024	321	145.6	19.0	482.6	18.25	463.6
50JX030	342	155.2	20.0	508	19.25	489
50JX036	350	158.8	20.0	508	19.0	482.6
50JX042	372	168.8	21.0	533.4	20.5	520.7
50JX048	377	171.0	20.0	508	21.25	539.8
50JX060	450	204.2	21.0	533.4	20.0	508.0

Fig. 9—Suggested Rigging

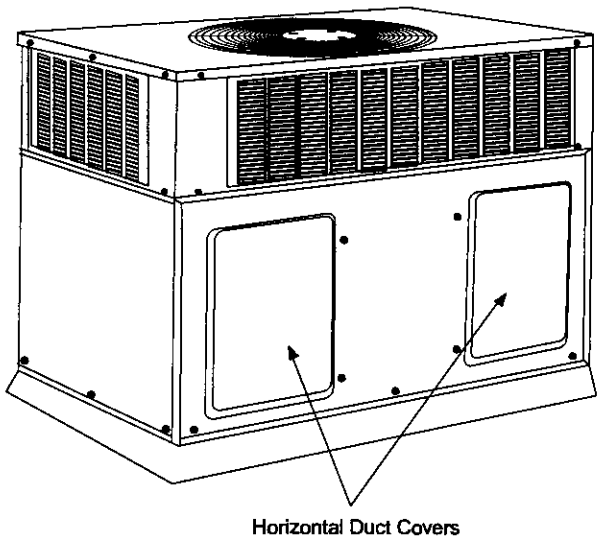

Fig. 11—50JX with Duct Covers On
(Unit Shown with Optional Louvered Grille)

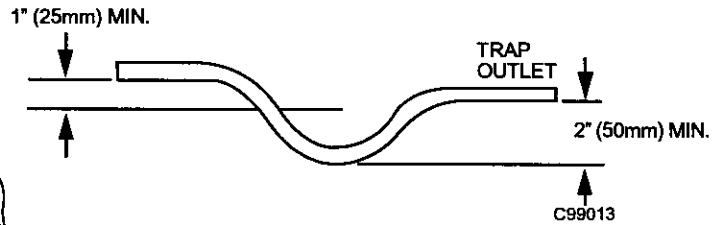

Fig. 12—Condensate Trap

CAUTION

Failure to follow these precautions could result in damage to the unit being installed:

1. Make all electrical connections in accordance with NEC ANSI/NFPA (latest edition) and local electrical codes governing such wiring. In Canada, all electrical connections must be in accordance with CSA standard C22.1 Canadian Electrical Code Part 1 and applicable local codes. Refer to unit wiring diagram.
2. Use only *copper* conductor for connections between field-supplied electrical disconnect switch and unit. **DO NOT USE ALUMINUM WIRE.**
3. Be sure that high-voltage power to unit is within operating voltage range indicated on unit rating plate. On 3-phase units, ensure phases are balanced within 2 percent. Consult local power company for correction of improper voltage and/or phase imbalance.
4. Insulate low-voltage wires for highest voltage contained within conduit when low-voltage control wires are in same conduit as high-voltage wires.
5. Do not damage internal components when drilling through any panel to mount electrical hardware, conduit, etc.

HIGH-VOLTAGE CONNECTIONS

The unit must have a separate electrical service with a field-supplied, waterproof disconnect switch mounted at, or within sight from the unit. Refer to the unit rating plate, NEC and local codes for maximum fuse/circuit breaker size and minimum circuit amps (ampacity) for wire sizing (See Tables 5 and 6 for electrical data).

The field-supplied disconnect may be mounted on the unit over the high-voltage inlet hole (See Fig. 2 and 3).

If the unit has an electric heater, a second disconnect may be required. Consult the Installation, Start-Up, and Service Instructions provided with the accessory for electrical service connections.

Operation of unit on improper line voltage constitutes abuse and may cause unit damage that could affect warranty.

ROUTING POWER LEADS INTO UNIT

Use only copper wire between disconnect and unit. The high-voltage leads should be in a conduit until they enter the duct panel; conduit termination at the duct panel must be watertight. Run the high-voltage leads through the power entry knockout on the power entry side panel. See Fig. 2 and 3 for location and size. When the leads are inside the unit, run leads up the high-voltage raceway to the line wiring splice box (See Fig. 13–19). For single-phase units, connect leads to the black and yellow wires; for 3-phase units, connect the leads to the black, yellow, and blue wires (See Fig. 18).

CONNECTING GROUND LEAD TO GROUND LUG

Connect the ground lead to the chassis using the ground lug in the wiring splice box (See Fig. 18).

Table 5—Electrical Data—50JS

UNIT 50JS SIZE	V-PH-HZ	VOLTAGE RANGE		COMPRESSOR		OFM FLA	IFM FLA	ELECTRIC HEAT		SINGLE POINT POWER SUPPLY		
		MIN	MAX	RLA	LRA			Nominal Kw*	FLA	MCA	FUSE OR CKT BKR	MOCP
018	208/230-1-60	187	253	9.0	48	0.9	1.8	-	-	14.0/14.0	20/20	-
								3.8/5.0	18.1/20.8	36.5/40.0	40/45	-
								5.4/7.2	26.0/30.0	46.4/51.5	50/60	-
								7.5/10.0	36.1/41.7	59.1/66.0	-	60/70
024	208/230-1-60	187	253	12.8	61	0.9	2.0	-	-	18.9/18.9	25/25	-
								3.8/5.0	18.1/20.8	41.5/44.9	45/45	-
								5.4/7.2	26.0/30.0	51.4/56.4	60/-	-70
								7.5/10.0	36.1/41.7	64.0/71.0	-	70/80
030	208/230-1-60	187	253	14.7	82	0.9	2.0	-	-	21.3/21.3	25/25	-
								3.8/5.0	18.1/20.8	43.8/47.3	45/50	-
								5.4/7.2	26.0/30.0	53.8/58.8	-	70/70
								7.5/10.0	36.1/41.7	66.4/73.4	-	70/80
	208/230-3-60	187	253	9.9	78	0.9	2.0	-	-	15.3/15.3	20/20	-
								3.8/5.0	10.4/12.0	28.3/30.3	30/35	-
								7.5/10.0	20.8/24.1	41.3/45.3	45/50	-
								11.3/15.0	31.3/36.1	54.4/60.4	60/-	-70
036	208/230-1-60	187	253	16.8	82	1.5	4.1	-	-	26.6/26.6	35/35	-
								3.8/5.0	18.1/20.8	49.2/52.6	50/60	-
								5.4/7.2	26.0/30.0	59.1/64.1	-	70/80
								7.5/10.0	36.1/41.7	71.7/78.7	-	80/80
	208/230-3-60	187	253	9.9	85	1.5	4.1	-	-	18.0/18.0	25/25	-
								3.8/5.0	10.4/12.0	31.0/33.0	35/35	-
								7.5/10.0	31.3/36.1	44.0/48.0	45/50	-
								11.3/15.0	36.1/41.7	57.1/63.1	60/-	-70
	460-3-60	414	506	5.5	40	0.8	1.9	-	-	9.6	15	-
								5	6.0	17.1	20	-
								10	12.0	24.6	25	-
								15	18.0	32.1	35	-
042	208/230-1-60	187	253	20.6	115	0.9	3.8	-	-	30.5/30.5	40/40	-
								3.8/5.0	18.1/20.8	53.0/56.5	60/60	-
								5.4/7.2	26.0/30.0	62.9/68.0	-	80/90
								7.5/10.0	36.1/41.7	75.6/82.5	-	80/90
	208/230-3-60	187	253	12.4	90	0.9	3.8	-	-	20.2/20.2	25/25	-
								3.8/5.0	10.4/12.0	33.2/35.2	40/40	-
								7.5/10.0	20.8/24.1	46.3/50.3	50/60	-
								11.3/15.0	31.3/36.1	59.3/65.3	60/-	-70
	460-3-60	414	506	6.7	45	0.8	1.8	-	-	11.0	15	-
								5	6.0	18.5	20	-
								10	12.0	26.0	30	-
								15	18.0	33.5	35	-
048	208/230-1-60	187	253	24.4	140	1.5	3.5	-	-	35.5/35.5	45/45	-
								3.8/5.0	18.1/20.8	58.1/61.5	-	70/70
								5.4/7.2	26.0/30.0	68.0/73.0	-	90/90
								7.5/10.0	36.1/41.7	80.6/87.6	-	90/100
	208/230-3-60	187	253	14.1	105	1.5	3.5	-	-	22.6/22.6	30/30	-
								3.8/5.0	10.4/12.0	35.7/37.7	40/40	-
								7.5/10.0	20.8/24.1	48.7/52.7	50/60	-
								11.3/15.0	31.3/36.1	61.7/67.7	-	70/70
	460-3-60	414	506	7.1	53	0.8	1.8	-	-	11.5	15	-
								5	6.0	19.0	20	-
								10	12.0	26.5	30	-
								15	18.0	34.0	35	-
060	208/230-1-60	187	253	28.8	165	1.5	6.2	-	-	43.7/43.7	60/60	-
								3.8/5.0	18.1/20.8	66.3/69.7	-	70/80
								5.4/7.2	26.0/30.0	76.2/81.2	-	100/110
								7.5/10.0	36.1/41.7	88.8/95.8	-	100/110
	208/230-3-60	187	253	19.4	125	1.5	6.2	-	-	32.0/32.0	40/40	-
								3.8/5.0	10.4/12.0	45.0/47.0	50/50	-
								7.5/10.0	20.8/24.1	58.0/62.1	-	60/70
								11.3/15.0	31.3/36.1	71.1/77.1	-	80/80
	460-3-60	414	506	8.0	63	0.8	3.2	-	-	14.0	20	-
								5	6.0	21.5	25	-
								10	12.0	29.0	30	-
								15	18.0	36.6	40	-
								20	21.5	29.0	30	-
								15	18.0	36.6	40	-
								20	24.1	44.1	45	-

Table 6—Electrical Data—50JX

UNIT 50JX SIZE	V-PH-HZ	VOLTAGE RANGE		COMPRESSOR		OFM FLA	IFM FLA	ELECTRIC HEAT		SINGLE POINT POWER SUPPLY		
		MIN	MAX	RLA	LRA			Nominal Kw*	FLA	MCA	FUSE OR CKT BKR	MOCP
024	208/230-1-60	187	253	10.8	56	0.90	2.0	-	-	16.4/16.4	20/20	-
								3.8/5.0	18.1/20.8	39.0/42.4	40/45	-
								5.4/7.2	26.0/30.0	48.9/53.9	60/60	-
								7.5/10.0	36.1/41.7	61.5/68.5	-	70/70
030	208/230-1-60	187	253	14.0	73	0.9	2.1	-	-	20.5/20.5	25/25	-
								3.8/5.0	18.1/20.8	43.1/46.5	45/50	-
								5.4/7.2	26.0/30.0	53.0/58.0	-	70/70
								7.5/10.0	36.1/41.7	65.6/72.6	-	70/80
	208/230-3-60	187	253	10.4	63	0.9	2.1	-	-	16.0/16.0	20/20	-
								3.8/5.0	10.4/12.0	29.0/31.0	35/35	-
								7.5/10.0	20.8/24.1	42.1/46.1	45/50	-
								11.3/15.0	31.3/36.1	55.1/61.1	-	60/70
036	208/230-1-60	187	253	16.7	97	1.6	3.6	-	-	26.1/26.1	35/35	-
								3.8/5.0	18.1/20.8	48.6/52.1	50/60	-
								5.4/7.2	26.0/30.0	58.6/63.6	-	70/80
								7.5/10.0	36.1/41.7	71.2/78.2	-	80/80
	208/230-3-60	187	253	11.2	75	1.6	3.6	-	-	19.2/19.2	25/25	-
								3.8/5.0	10.4/12.0	32.2/34.2	35/35	-
								7.5/10.0	20.8/24.1	45.2/49.3	50/50	-
								11.3/15.0	31.3/36.1	58.3/64.3	-	60/70
	460-3-60	414	506	5.4	37.5	0.9	1.9	-	-	9.6	15	-
								5	6	17.1	20	-
								10	12	24.6	25	-
								15	18	32.1	35	-
042	208/230-1-60	187	253	18.4	104	0.9	4.1	-	-	28.0/28.0	35/35	-
								3.8/5.0	18.1/20.8	50.6/54.0	60/60	-
								5.4/7.2	26.0/30.0	60.5/65.5	-	80/80
								7.5/10.0	36.1/41.7	73.1/80.1	-	80/90
	208/230-3-60	187	253	12.4	88	0.9	4.1	-	-	20.5/20.5	25/25	-
								3.8/5.0	10.4/12.0	33.5/35.5	40/40	-
								7.5/10.0	20.8/24.1	46.6/50.6	50/60	-
								11.3/15.0	31.3/36.1	59.6/65.6	-	60/70
	460-3-60	414	506	5.8	44	0.9	2.0	-	-	10.2	15	-
								5	6	17.7	20	-
								10	12	25.2	30	-
								15	18	32.7	35	-
208/230-1-60	187	253	23.4	126	1.6	4.1	-	-	34.9/34.9	45/45	-	
							3.8/5.0	18.1/20.8	57.4/60.9	-	70/70	
							5.4/7.2	26.0/30.0	67.3/72.4	-	90/90	
							7.5/10.0	36.1/41.7	80.0/86.9	-	90/90	
208/230-3-60	187	253	13.0	93	1.6	4.1	-	-	21.9/21.9	30/30	-	
							3.8/5.0	10.4/12.0	34.9/36.9	40/40	-	
							7.5/10.0	20.8/24.1	47.9/51.9	50/60	-	
							11.3/15.0	31.3/36.1	60.9/67.0	-	70/70	
460-3-60	414	506	6.4	46.5	0.9	2.0	-	-	10.8	15	-	
							5	6	18.3	20	-	
							10	12	25.8	30	-	
							15	18	33.3	35	-	
048	208/230-1-60	187	253	28.8	169	1.4	6.2	-	-	43.6/43.6	60/60	-
								3.8/5.0	18.1/20.8	66.2/69.6	-	70/80
								5.4/7.2	26.0/30.0	76.1/81.1	-	100/110
								7.5/10.0	36.1/41.7	88.7/95.7	-	100/100
	208/230-3-60	187	253	17.3	123	1.4	6.2	-	-	29.2/29.2	35/35	-
								3.8/5.0	10.4/12.0	42.3/44.3	50/50	-
								7.5/10.0	20.8/24.1	55.2/59.4	60/60	-
								11.3/15.0	31.3/36.1	68.3/74.3	-	70/80
	460-3-60	414	506	9.0	62	0.9	3.2	-	-	15.4	20	-
								5	6	22.9	25	-
								10	12	30.4	35	-
								15	18	37.9	40	-
208/230-1-60	187	253	28.8	169	1.4	6.2	-	-	133.9/147.8	-	-	
							3.8/5.0	18.1/20.8	111.3/121.7	-	125/125	
							5.4/7.2	26.0/30.0	133.9/147.8	-	150/150	
							7.5/10.0	36.1/41.7	-	-	-	
208/230-3-60	187	253	17.3	123	1.4	6.2	-	-	81.2/89.2	-	-	
							3.8/5.0	10.4/12.0	81.2/89.2	-	90/90	
							7.5/10.0	20.8/24.1	-	-	-	
							11.3/15.0	31.3/36.1	-	-	-	
460-3-60	414	506	9.0	62	0.9	3.2	-	-	45.4	50	-	
							5	6	-	-	-	
							10	12	-	-	-	
							15	18	-	-	-	
208/230-1-60	187	253	28.8	169	1.4	6.2	-	-	45.4	50	-	
							3.8/5.0	18.1/20.8	-	-	-	
							5.4/7.2	26.0/30.0	-	-	-	
							7.5/10.0	36.1/41.7	-	-	-	
208/230-3-60	187	253	17.3	123	1.4	6.2	-	-	45.4	50	-	
							3.8/5.0	10.4/12.0	-	-	-	
							7.5/10.0	20.8/24.1	-	-	-	
							11.3/15.0	31.3/36.1	-	-	-	
460-3-60	414	506	9.0	62	0.9	3.2	-	-	45.4	50	-	
							5	6	-	-	-	
							10	12	-	-	-	
							15	18	-	-	-	

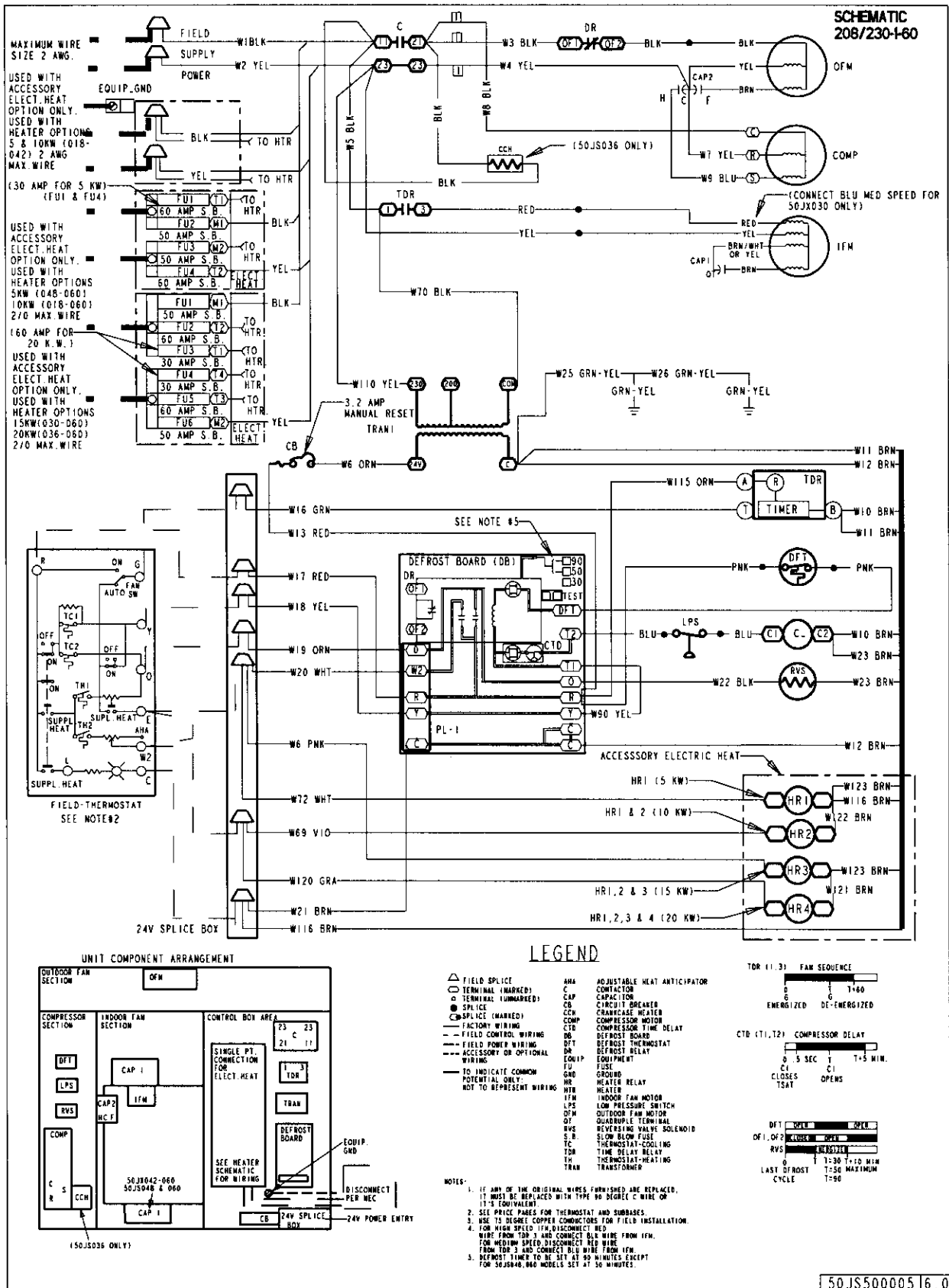

Fig. 13—Wiring Schematics (208/230-1-60)

ROUTING CONTROL POWER WIRES (24-V)

Form a drip-loop with the thermostat leads before routing them into the unit. Route the thermostat leads through grommets,

low-voltage hole provided in unit into unit control power splice box (See Fig. 2 and 3). Connect thermostat leads to unit control power leads as shown in Fig. 17.

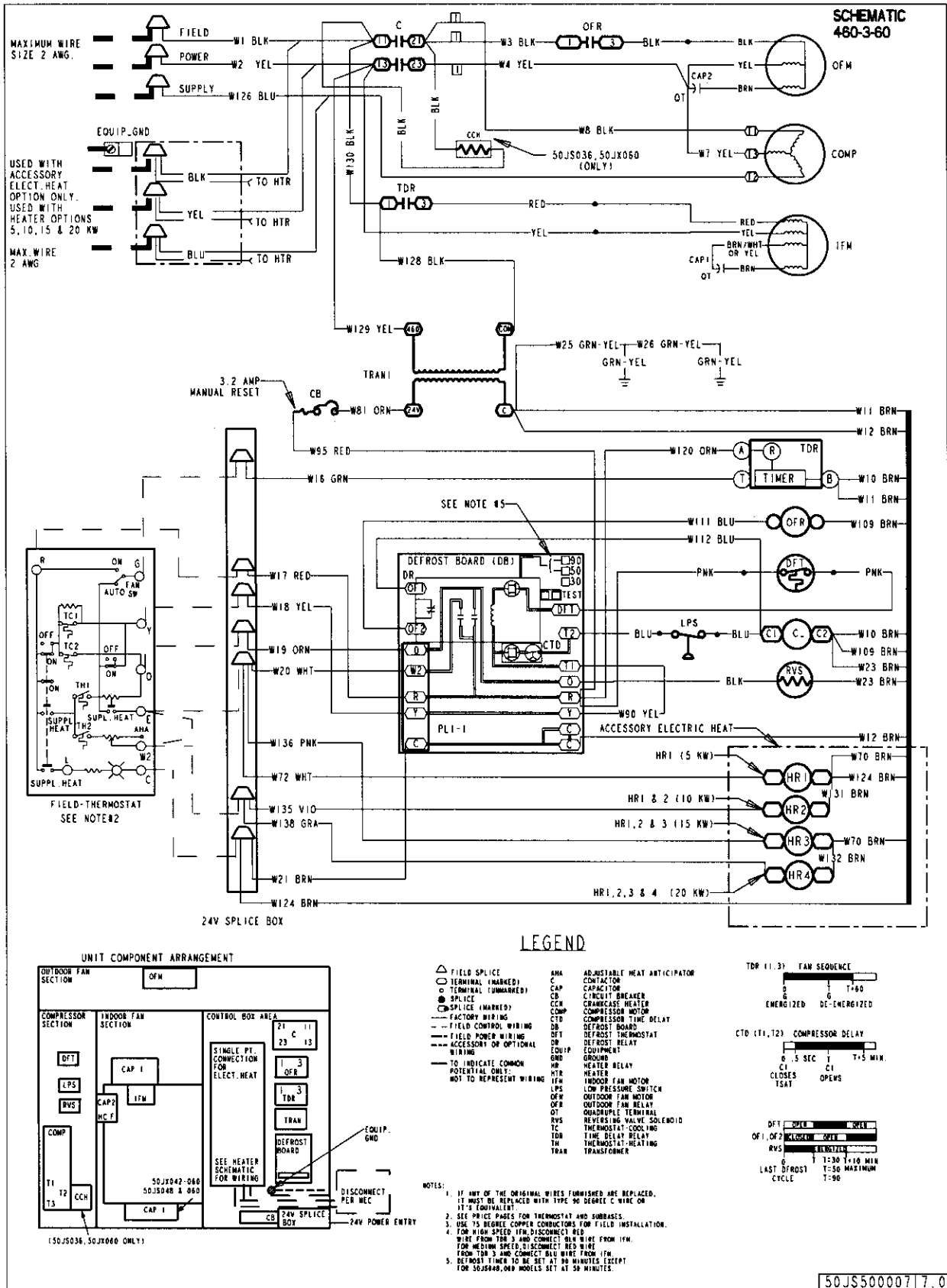

Fig. 15—Wiring Schematics (460-3-60)

for 230-v operation. If supply voltage is 208-v, rewire transformer primary as described in Special Procedures for 208-v Operation section.

SPECIAL PROCEDURES FOR 208-V OPERATION

1. Disconnect the yellow primary lead from the transformer. See unit wiring label (See Fig. 13 and 14).

- LEGEND**
- FLA — Full Load Amps
 - LRA — Locked Rotor Amps
 - MCA — Minimum Circuit Amps
 - MOCP — Maximum Overcurrent Protection
 - RLA — Rated Load Amps
 - CKT BKR — Circuit Breaker



NOTES:

1. In compliance with NEC (National Electrical Code) requirements for multimotor and combination load equipment (refer to NEC Articles 430 and 440), the overcurrent protective device for the unit shall be Power Supply fuse. Canadian units may be fuse or circuit breaker.
2. Minimum wire size is based on 60 C copper wire. If other than 60 C wire is used, or if length exceeds wire length in table, determine size from NEC.
3. Unbalanced 3-Phase Supply Voltage
Never operate a motor where a phase imbalance in supply voltage is greater than 2%. Use the following formula to determine the percentage of voltage imbalance.

% Voltage imbalance

$$= 100 \times \frac{\text{max voltage deviation from average voltage}}{\text{average voltage}}$$

EXAMPLE: Supply voltage is 460-3-60.

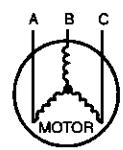

AB = 452 v
 BC = 464 v
 AC = 455 v

$$\text{Average Voltage} = \frac{452 + 464 + 455}{3}$$

$$= \frac{1371}{3}$$

$$= 457$$

Determine maximum deviation from average voltage.

- (AB) 457 452 = 5 v
- (BC) 464 457 = 7 v
- (AC) 457 455 = 2 v

Maximum deviation is 7 v.

Determine percent of voltage imbalance.

$$\% \text{ Voltage Imbalance} = 100 \times \frac{7}{457}$$

$$= 1.53\%$$

This amount of phase imbalance is satisfactory as it is below the maximum allowable 2%.

IMPORTANT: If the supply voltage phase imbalance is more than 2%, contact your local electric utility company immediately.

C99024

Fig. 16—Electrical Data Legend

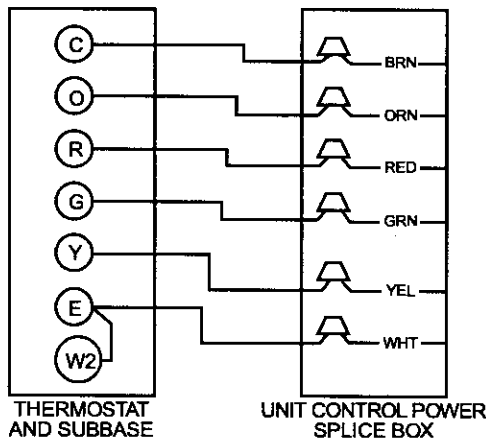

C99056

Fig. 17—Control Connections

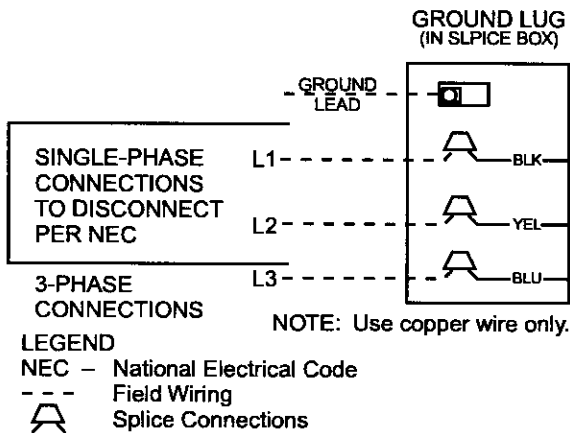

C99057

Fig. 18—Line Power Connections

2. Connect the yellow primary lead to the transformer terminal labeled 200-v.

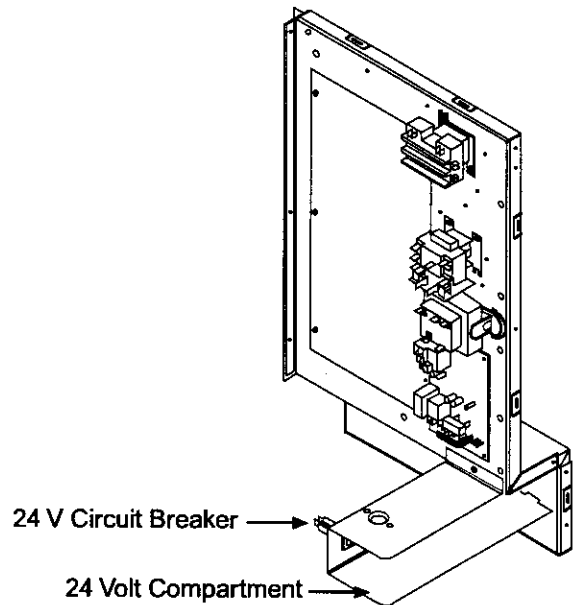

C99070

Fig. 19—Control Wiring Plate

TRANSFORMER CONTAINS A MANUAL RESET OVERCURRENT PROTECTOR

IT WILL NOT AUTOMATICALLY RESET

DISCONNECT POWER AND INSTALL LOCKOUT TAG PRIOR TO SERVICING

THIS COMPARTMENT MUST BE CLOSED EXCEPT WHEN SERVICING

C99058

Fig. 20—Transformer Label

Indoor blower-motor speeds may need to be changed for 208-v operation. Refer to indoor airflow and airflow adjustments section.

PRE-START-UP

▲ WARNING

Failure to observe the following warnings could result in serious personal injury or death:

1. Follow recognized safety practices and wear protective goggles when checking or servicing refrigerant system.
2. Do not operate compressor or provide any electric power to unit unless compressor terminal cover is in place and secured.
3. Do not remove compressor terminal cover until all electrical sources are disconnected and tagged.
4. Relieve and recover all refrigerant from system before touching or disturbing anything inside terminal box if refrigerant leak is suspected around compressor terminals.
5. Never attempt to repair soldered connection while refrigerant system is under pressure.
6. Do not use torch to remove any component. System contains oil and refrigerant under pressure. To remove a component, wear protective goggles and proceed as follows:
 - a. Shut off electrical power to unit and install lockout tag.
 - b. Relieve and reclaim all refrigerant from system using both high- and low-pressure ports.
 - c. Cut component connecting tubing with tubing cutter and remove component from unit.
 - d. Carefully unsweat remaining tubing stubs when necessary. Oil can ignite when exposed to torch flame.

Use the Start-Up Checklist supplied at the end of this book and proceed as follows to inspect and prepare the unit for initial start-up:

1. Remove access panel.
2. Read and follow instructions on all DANGER, WARNING, CAUTION, and INFORMATION labels attached to, or shipped with, unit.
3. Make the following inspections:
 - a. Inspect for shipping and handling damages such as broken lines, loose parts, disconnected wires, etc.
 - b. Inspect for oil at all refrigerant tubing connections and on unit base. Detecting oil generally indicates a refrigerant leak. Leak-test all refrigerant tubing connections using electronic leak detector, or liquid-soap solution. If a refrigerant leak is detected, see following Check for Refrigerant Leaks section.
 - c. Inspect all field and factory-wiring connections. Be sure that connections are completed and tight.
 - d. Ensure wires do not touch refrigerant tubing or sharp sheetmetal edges.
 - e. Inspect coil fins. If damaged during shipping and handling, carefully straighten fins with a fin comb.
4. Verify the following conditions:
 - a. Make sure that outdoor-fan blade is correctly positioned in fan orifice (See Fig. 21).
 - b. Make sure that condensate drain pan and trap are filled with water to ensure proper drainage.
 - c. Make sure that all tools and miscellaneous loose parts have been removed.
5. Compressors are internally spring mounted. Do not loosen or remove compressor holddown bolts.
6. Each unit system has 2 Schrader-type ports, one low-side Schrader fitting located on the suction line, and one high-side

Schrader fitting located on the compressor discharge line. Be sure that caps on the ports are tight.

7. High flow valves are located on the compressor hot gas and suction tubes. These valves can not be accessed for service in the field. Ensure the plastic caps are in place and tight or the possibility of refrigerant leakage could occur.

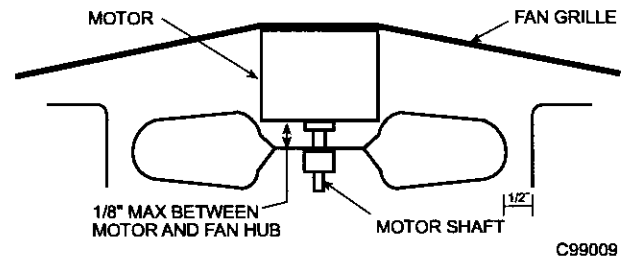

Fig. 21—Fan Blade Clearance

START-UP

Using the Start-Up Checklist supplied at the end of this book, proceed as follows:

Step 1—Check for Refrigerant Leaks

Locate and repair refrigerant leaks and charge the unit as follows:

1. Use both high- and low-pressure ports to relieve system pressure and reclaim remaining refrigerant.
2. Repair leak following accepted practices.

NOTE: Install a bi-flow filter drier whenever the system has been opened for repair.

3. Check system for leaks using an approved method.
4. Reclaim refrigerant and evacuate refrigerant system to 500 microns if no additional leaks are found.
5. Charge unit with R-22 refrigerant, using a volumetric-charging cylinder or accurate scale. Refer to unit rating plate for required charge. Be sure to add extra refrigerant to compensate for internal volume of filter drier.

Step 2—Start-Up Adjustments

Complete the required procedures given in the Pre-Start-Up section before starting the unit. Do not jumper any safety devices when operating the unit. Do not operate the unit in Cooling mode when the outdoor temperature is below 40° F (unless accessory low-ambient kit is installed). Do not rapid-cycle the compressor. Allow 5 minute between "on" cycles to prevent compressor damage.

CHECKING COOLING AND HEATING CONTROL OPERATION

Start and check the unit for proper control operation as follows:

1. Place room thermostat SYSTEM switch in OFF position. Observe that blower motor starts when FAN switch is placed in ON position and shuts down within 60 sec. when FAN switch is placed in AUTO position.
2. Place SYSTEM switch in COOL position and FAN switch in AUTO position. Set control below room temperature. Observe that cooling cycle shuts down when control setting is satisfied.
3. Place system switch in HEAT position. Set control above room temperature. Observe that compressor, outdoor fan, and indoor blower motors start. Observe that heating cycle shuts down when control setting is satisfied.
4. When using an automatic changeover room thermostat, place both SYSTEM and FAN switches in AUTO positions. Observe that unit operates in Cooling mode when temperature control is set to "call for Cooling" (below room temperature),

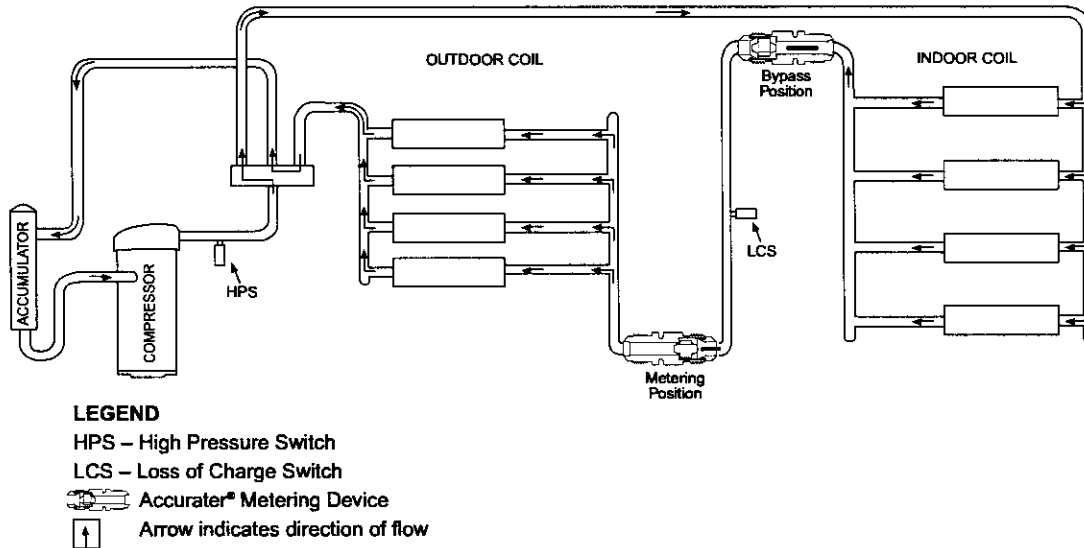

C00095

Fig. 22—Typical Heat Pump Operation, Heating Mode

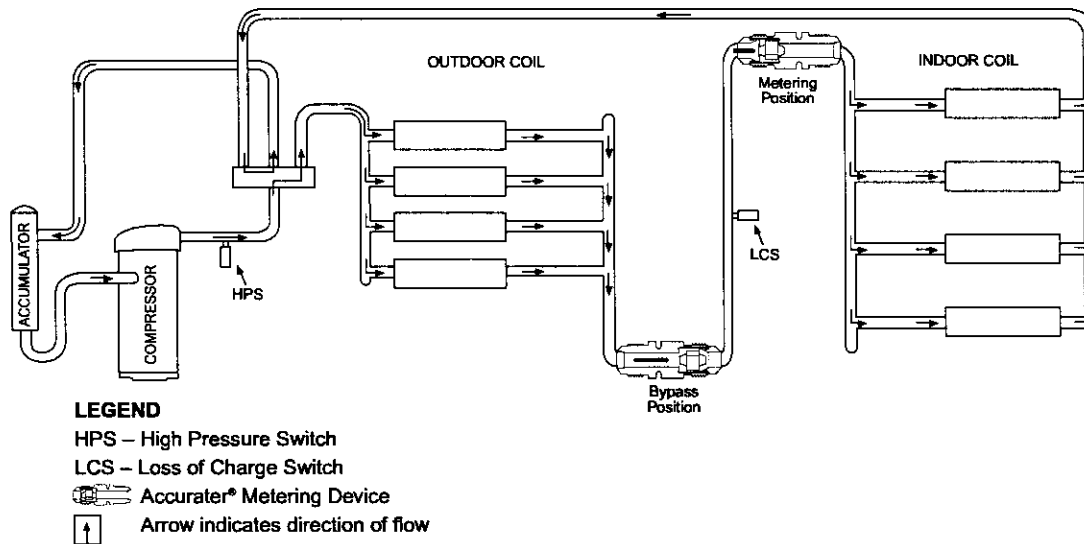

C00096

Fig. 23—Typical Heat Pump Operation, Cooling Mode

and unit operates in Heating mode when temperature control is set to “call for Heating” (above room temperature).

IMPORTANT: Three-phase, scroll compressors are direction oriented. Unit must be checked to ensure proper compressor 3-phase power lead orientation. If not corrected within 5 minute, the internal protector will shut off the compressor. The 3-phase power leads to the unit must be reversed to correct rotation. When turning backwards, scroll compressors emit elevated noise levels, and the difference between compressor suction and discharge pressures may be dramatically lower than normal.

CHECKING AND ADJUSTING REFRIGERANT CHARGE

The refrigerant system is fully charged with R-22 refrigerant and is tested and factory sealed. Allow system to operate a minimum of 15 minutes before checking or adjusting charge.

NOTE: Adjustment of the refrigerant charge is not required unless the unit is suspected of not having the proper R-22 charge. The charging label and the tables shown refer to system temperatures and pressures in cooling mode only. A refrigerant charging

label is attached to the outside of the service access door. If charge level is suspect in Heating mode, reclaim all refrigerant and charge to nameplate amount. (This information may be obtained from the physical data table also.)

IMPORTANT: When evaluating the refrigerant charge, an indicated adjustment to the specified factory charge must always be very minimal. If a substantial adjustment is indicated, an abnormal condition exists somewhere in the cooling system, such as insufficient airflow across either coil or both coils.

REFRIGERANT CHARGE

The amount of refrigerant charge is listed on the unit nameplate and/or the physical data table. Refer to the Refrigeration Service Techniques Manual, Refrigerants Section.

NO CHARGE

Check for leak. Use standard evacuating techniques. After evacuating system to 500 microns, weigh in the specified amount of refrigerant (refer to system data plate).

Balance Point Worksheet

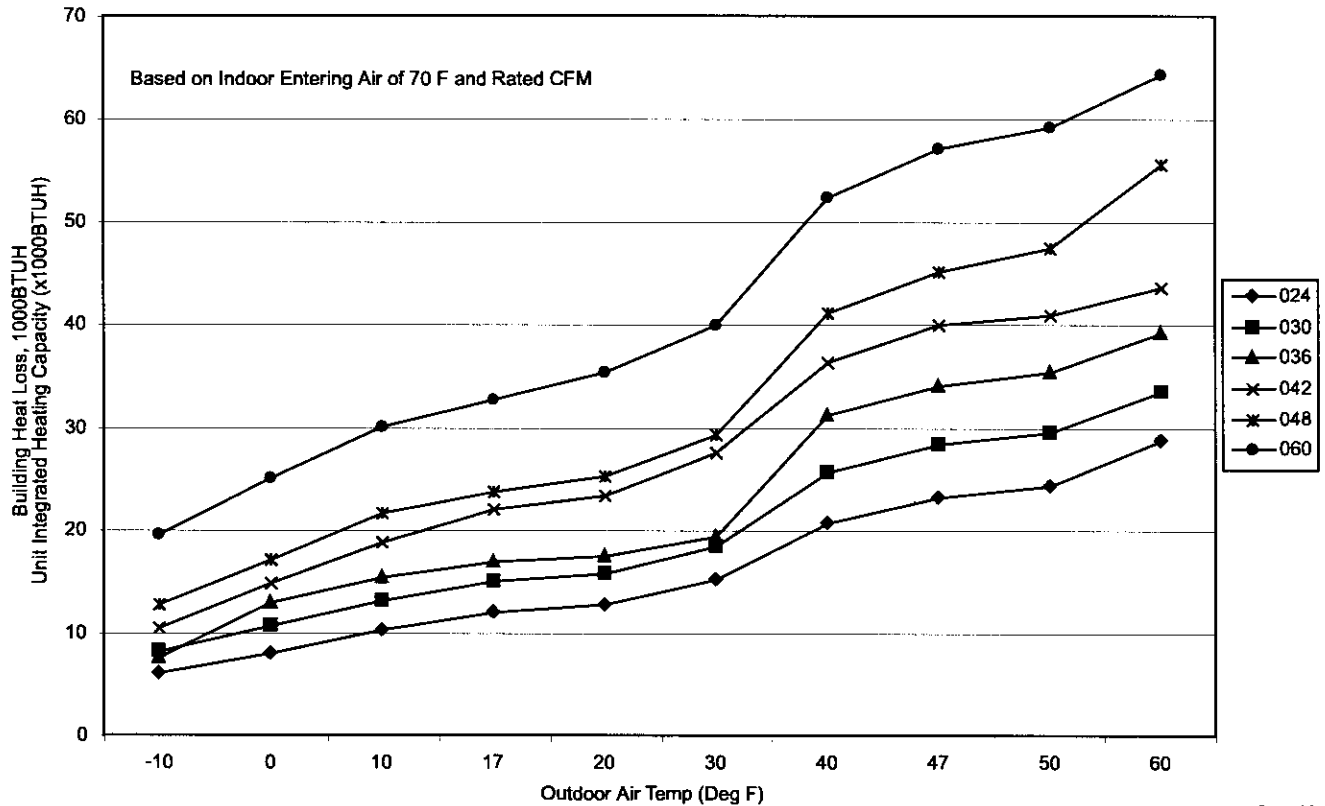

C00093

Fig. 24—50JX Balance Point Worksheet

LOW CHARGE COOLING

Use Cooling Charging Charts (Fig. 26-38). Vary refrigerant until the conditions of the chart are met. Note that charging charts are different from type normally used. Charts are based on charging the units to correct superheat for the various operating conditions. Accurate pressure gage and temperature sensing devices are required. Connect the pressure gage to the service port on the suction line. Mount the temperature sensing device on the suction line and insulate it so that the outdoor ambient does not affect the reading. Indoor air CFM must be within the normal operating range of the unit.

TO USE COOLING CHARGING CHARTS

Take the outdoor ambient temperature and read the suction pressure gage. Refer to the chart to determine what the suction temperature should be.

NOTE: If the problem causing the inaccurate readings is a refrigerant leak, refer to Check for Refrigerant Leaks section.

INDOOR AIRFLOW AND AIRFLOW ADJUSTMENTS

⚠ CAUTION

For heating and cooling operation, the recommended airflow is 350 to 450 cfm for each 12,000 Btuh of rated cooling capacity. For units with optional electric heat, the airflow must not be reduced below the levels stated in Tables 3 and 4. Failure to maintain these airflows could result in damage to the unit.

Tables 7 and 8 shows both heating and cooling airflows at various external static pressures. Refer to these tables to determine the airflow for the system being installed.

NOTE: Be sure that all supply-and return-air grilles are open, free from obstructions, and adjusted properly.

Airflow can be changed by changing the lead connection of the blower motor.

Unit 50JS and 50JX three-speed motors (except sizes 50JS 018 and 50JX 030) are factory wired for low speed operation. Unit 50JX 030 is factory wired for medium speed. Unit 50JS 018 has a two-speed motor wired for low speed.

For 208/230-v Motors:— The motor leads are color-coded as follows:

- 3-SPEED
- Black = high speed
- Blue = medium speed
- Red = low speed

To change the speed of the indoor fan motor (IFM), remove the fan motor speed leg lead from the Time Delay Relay (TDR). This wire is attached to TDR-3 for single-phase and 3-phase units. To change the speed, remove and replace with lead for desired blower motor speed. *Insulate the removed lead* to avoid contact with chassis parts.

For 460-v GE Motors—The motor leads are color coded as follows:

- 3-SPEED
- Black = high
- Violet = jumper
- Orange = medium
- Red = low

To change the speed of the indoor fan motor (IFM), remove fan motor speed lead from the Time Delay Relay (TDR) and replace with the lead for the desired blower motor speed. The motor speed lead is attached to terminal TDR-3. For low and medium speeds,

Balance Point Worksheet

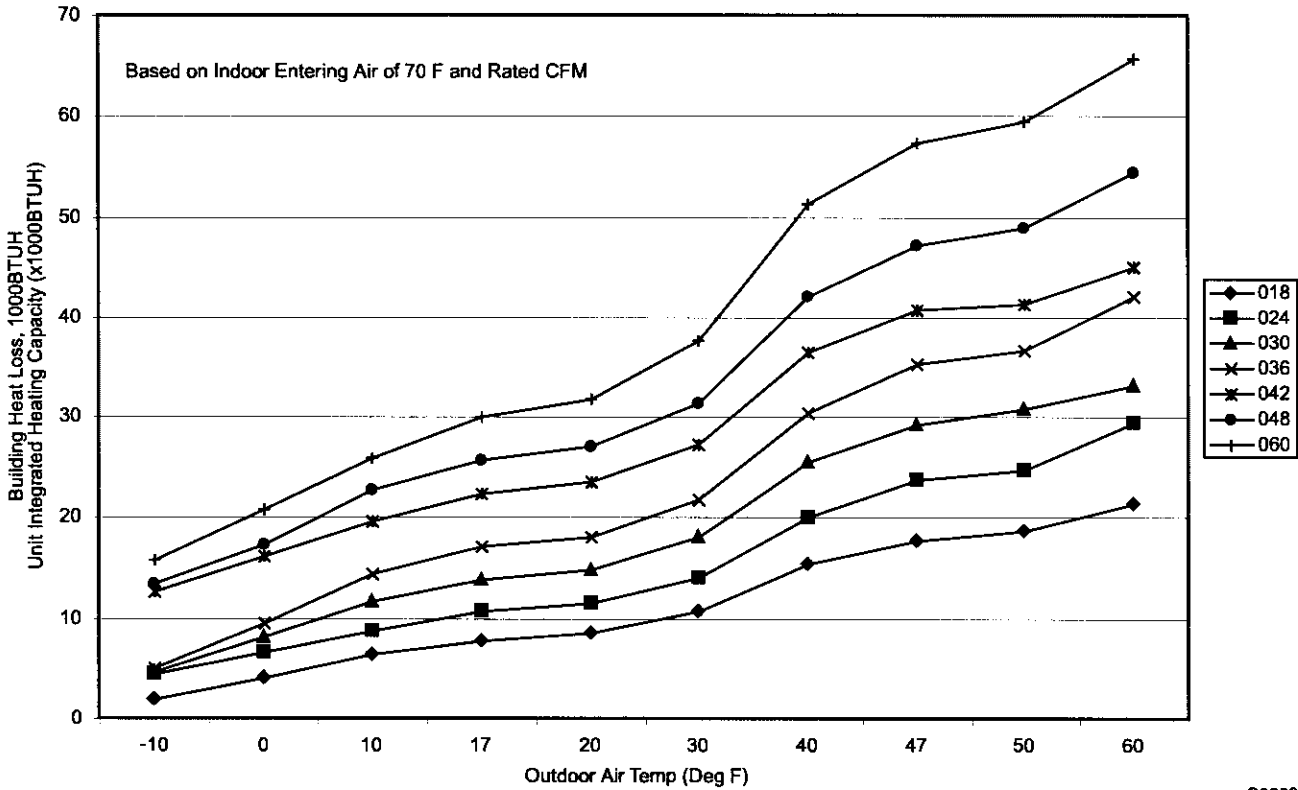

C00094

Fig. 25—50JS Balance Point Worksheet

black must be connected to the jumper wire. Insulate removed lead end to avoid contact with chassis parts. To select high speed on 460-v GE motors, separate the black female quick connect (QC) from the jumper lead male quick connect (QC) and connect the black lead to the BR. Insulate the jumper to avoid contact with any chassis parts.

MAINTENANCE

To ensure continuing high performance, and to minimize the possibility of premature equipment failure, periodic maintenance must be performed on this equipment. This heat pump unit should be inspected at least once each year by a qualified service person. To troubleshoot unit, refer to Table 11.

NOTE TO EQUIPMENT OWNER: Consult your local dealer about the availability of a maintenance contract.

⚠ WARNING

The ability to properly perform maintenance on this equipment requires certain expertise, mechanical skills, tools and equipment. If you do not possess these, do not attempt to perform any maintenance on this equipment, other than those procedures recommended in the User's Manual. **FAILURE TO HEED THIS WARNING COULD RESULT IN SERIOUS INJURY OR DEATH AND POSSIBLE DAMAGE TO THIS EQUIPMENT.**

⚠ WARNING

Failure to follow these warnings could result in serious injury or death:

1. Turn off electrical power to the unit and install lockout tag before performing any maintenance or service on this unit.
2. Use extreme caution when removing panels and parts. As with any mechanical equipment, personal injury can result from sharp edges.
3. Never place anything combustible either on, or in contact with, the unit.

⚠ CAUTION

Errors made when reconnecting wires may cause improper and dangerous operation. Label all wires prior to disconnecting when servicing.

The minimum maintenance requirements for this equipment are as follows:

1. Inspect air filter(s) each month. Clean or replace when necessary.
2. Inspect indoor coil, drain pan, and condensate drain each cooling season for cleanliness. Clean when necessary.
3. Inspect blower motor and wheel for cleanliness each cooling season. Clean when necessary.
4. Check electrical connections for tightness and controls for proper operation each cooling season. Service when necessary.
5. Ensure wires are not contacting refrigerant tubing or sharp sheet metal edges.

**Table 7—Wet Coil Air Delivery
Unit 50JS 018-060 (Deduct 10 percent for 208-V)***

UNIT	MOTOR SPEED		EXTERNAL STATIC PRESSURE (IN. WG)											
			0.0	0.1	0.2	0.3	0.4	0.5	0.6	0.7	0.8	0.9	1.0	
018	Low	Watts	-	-	-	214	191	170	-	-	-	-	-	-
		Cfm	-	-	-	821	696	575	-	-	-	-	-	-
	Med	Watts	-	-	-	-	-	-	-	-	-	-	-	-
		Cfm	-	-	-	-	-	-	-	-	-	-	-	-
	High	Watts	-	-	-	-	283	274	267	-	-	-	-	-
		Cfm	-	-	-	-	848	707	555	-	-	-	-	-
024	Low	Watts	-	-	237	214	191	-	-	-	-	-	-	
		Cfm	-	-	971	821	696	-	-	-	-	-	-	
	Med	Watts	-	-	-	-	368	366	365	360	-	-	-	
		Cfm	-	-	-	-	957	872	785	688	-	-	-	
	High	Watts	-	-	-	-	-	-	-	425	414	-	-	
		Cfm	-	-	-	-	-	-	-	891	735	-	-	
30	Low	Watts	295	292	289	-	-	-	-	-	-	-	-	
		Cfm	928	882	802	-	-	-	-	-	-	-	-	
	Med	Watts	388	383	377	372	366	361	-	-	-	-	-	
		Cfm	1203	1120	1062	1004	930	838	-	-	-	-	-	
	High	Watts	-	-	-	-	469	458	449	442	-	-	-	
		Cfm	-	-	-	-	1141	1027	924	828	-	-	-	
36	Low	Watts	592	581	567	552	538	525	512	499	-	-	-	
		Cfm	1499	1421	1351	1281	1207	1125	1034	936	-	-	-	
	Med	Watts	-	-	-	660	636	617	603	592	581	566	-	
		Cfm	-	-	-	1475	1371	1274	1186	1105	1024	928	-	
	High	Watts	-	-	-	-	-	776	761	744	725	706	689	
		Cfm	-	-	-	-	-	1452	1356	1254	1145	1030	910	
42	Low	Watts	606	596	586	575	563	550	537	-	-	-	-	
		Cfm	1464	1399	1341	1282	1218	1146	1066	-	-	-	-	
	Med	Watts	680	665	649	635	622	611	600	590	-	-	-	
		Cfm	1608	1535	1461	1387	1316	1247	1180	1111	-	-	-	
	High	Watts	768	755	742	730	718	707	696	684	671	-	-	
		Cfm	1656	1576	1508	1447	1390	1331	1268	1198	1119	-	-	
48	Low	Watts	741	724	709	690	664	631	594	562	543	552	-	
		Cfm	1994	1937	1869	1797	1722	1645	1566	1480	1384	1269	-	
	Med	Watts	-	-	-	773	744	715	687	662	640	625	-	
		Cfm	-	-	-	1957	1867	1787	1719	1653	1575	1463	-	
	High	Watts	-	-	-	-	-	799	782	773	756	704	-	
		Cfm	-	-	-	-	-	1914	1842	1774	1686	1538	-	
60	Low	Watts	742	723	698	666	629	591	559	540	-	-	-	
		Cfm	2197	2141	2103	2057	1988	1894	1783	1674	-	-	-	
	Med	Watts	838	822	803	780	752	721	689	661	639	632	-	
		Cfm	2485	2406	2269	2127	2012	1937	1894	1855	1770	1571	-	
	High	Watts	-	934	913	891	866	837	806	776	750	735	-	
		Cfm	-	2483	2391	2283	2170	2061	1960	1868	1780	1687	-	

* Air delivery values are based on operating voltage of 230-v or 460-v, wet coil, without filter or electric heater. Deduct filter and electric heater pressure drops to obtain static pressure available for ducting.

NOTES:

1. Do not operate the unit at a cooling airflow that is less than 350 cfm for each 12,000 Btuh of rated cooling capacity. Evaporator coil frosting may occur at airflows below this point.
2. Dashes indicate portions of table that are beyond the blower motor capacity or are not recommended.
3. Deduct 10 percent for 208-v.

Step 1—Air Filter

IMPORTANT: Never operate the unit without a suitable air filter in the return-air duct system. Always replace the filter with the same dimensional size and type as originally installed (See Tables 1 and 2 for recommended filter sizes.)

Inspect air filter(s) at least once each month and replace (throwaway-type) or clean (cleanable-type) at least twice during each cooling season or whenever the filter becomes clogged with dust and lint.

Step 2—Indoor blower and motor

NOTE: All motors are prelubricated. Do not attempt to lubricate these motors.

For longer life, operating economy, and continuing efficiency, clean accumulated dirt and grease from the blower wheel and motor annually.

**Table 8—Wet Coil Air Delivery
Unit 50JX 024-060 (Deduct 10 percent for 208-V)***

UNIT	MOTOR SPEED		EXTERNAL STATIC PRESSURE (IN. WG)										
			0.0	0.1	0.2	0.3	0.4	0.5	0.6	0.7	0.8	0.9	1.0
024	Low	Watts	275	273	271	270	-	-	-	-	-	-	-
		Cfm	923	844	754	669	-	-	-	-	-	-	-
	Med	Watts	-	-	-	359	353	350	347	341	-	-	-
		Cfm	-	-	-	941	876	814	737	622	-	-	-
	High	Watts	-	-	-	-	-	-	447	439	431	423	-
		Cfm	-	-	-	-	-	-	968	869	765	659	-
30	Low	Watts	276	276	272	-	-	-	-	-	-	-	-
		Cfm	963	929	781	-	-	-	-	-	-	-	-
	Med	Watts	375	377	371	362	354	350	-	-	-	-	-
		Cfm	1202	1170	1079	976	884	807	-	-	-	-	-
	High	Watts	-	-	-	-	469	449	435	428	-	-	-
		Cfm	-	-	-	-	1174	988	828	718	-	-	-
36	Low	Watts	462	451	431	411	394	381	-	-	-	-	-
		Cfm	1374	1290	1205	1116	1020	916	-	-	-	-	-
	Med	Watts	523	506	490	471	449	426	-	-	-	-	-
		Cfm	1500	1408	1301	1190	1082	977	-	-	-	-	-
	High	Watts	-	645	628	610	595	584	575	-	-	-	-
		Cfm	-	1474	1369	1267	1169	1069	962	-	-	-	-
42	Low	Watts	620	600	586	574	562	548	530	510	487	462	439
		Cfm	1662	1621	1581	1540	1496	1447	1392	1331	1263	1186	1103
	Med	Watts	-	-	-	-	686	661	634	606	577	547	517
		Cfm	-	-	-	-	1722	1662	1594	1515	1427	1330	1227
	High	Watts	-	-	-	-	-	-	-	757	730	704	682
		Cfm	-	-	-	-	-	-	-	1669	1577	1486	1402
48	Low	Watts	620	600	586	574	562	548	530	-	487	-	-
		Cfm	1662	1621	1581	1540	1496	1447	1392	1331	1263	-	-
	Med	Watts	763	747	729	709	686	661	634	606	577	547	517
		Cfm	1917	1868	1822	1774	1722	1662	1594	1515	1427	1330	1227
	High	Watts	-	-	-	852	832	809	784	757	730	704	682
		Cfm	-	-	-	1982	1914	1839	1757	1669	1577	1486	1402
60	Low	Watts	597	592	578	526	460	452	445	-	-	-	-
		Cfm	2265	2190	2101	2033	1974	1869	1614	-	-	-	-
	Med	Watts	754	730	707	687	671	658	646	630	603	558	486
		Cfm	2383	2282	2202	2134	2070	2005	1935	1858	1771	1667	1576
	High	Watts	901	876	856	836	813	785	755	723	696	681	687
		Cfm	2480	2383	2301	2233	2175	2122	2066	1998	1910	1788	1619

* Air delivery values are based on operating voltage of 230-v or 460-v, wet coil, without filter or electric heater. Deduct filter and electric heater pressure drops to obtain static pressure available for ducting.

NOTES:

1. Do not operate the unit at a cooling airflow that is less than 350 cfm for each 12,000 Btuh of rated cooling capacity. Evaporator coil frosting may occur at airflows below this point.
2. Dashes indicate portions of table that are beyond the blower motor capacity or are not recommended.
3. Deduct 10 percent for 208-v.

⚠ WARNING

Disconnect and tag electrical power to the unit before cleaning and lubricating the blower motor and wheel. Failure to adhere to this warning could cause serious injury or death.

Step 3—OUTDOOR COIL, INDOOR COIL, AND CONDENSATE DRAIN PAN

Inspect the condenser coil, evaporator coil, and condensate drain pan at least once each heating and cooling season or sooner if conditions require.

The coils are easily cleaned when dry; therefore, inspect and clean the coils either before or after each cooling season. Remove all obstructions, including weeds and shrubs, that interfere with the airflow through the condenser coil.

Straighten bent fins with a fin comb. If coated with dirt or lint, clean the coils with a vacuum cleaner, using the soft brush

attachment. Be careful not to bend the fins. If coated with oil or grease, clean the coils with a mild detergent-and-water solution. Rinse coils with clear water, using a garden hose. Be careful not to splash water on motors, insulation, wiring, or air filter(s). For best results, spray condenser coil fins from inside to outside the unit. On units with an outer and inner condenser coil, be sure to clean between the coils. Be sure to flush all dirt and debris from the unit base.

Inspect the drain pan and condensate drain line when inspecting the coils. Clean the drain pan and condensate drain by removing all foreign matter from the pan. Flush the pan and drain trough with clear water. Do not splash water on the insulation, motor, wiring, or air filter(s). If the drain trough is restricted, clear it with a “plumbers snake” or similar probe device. Ensure that the auxiliary drain port above the drain trough is also clear.

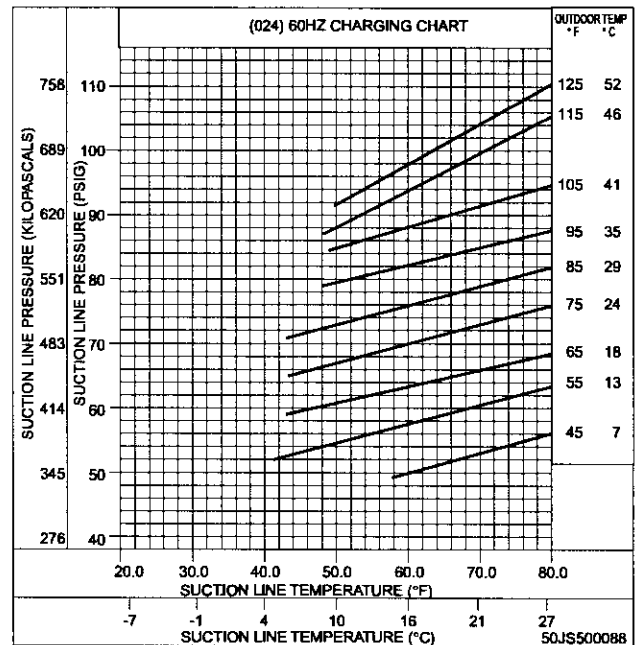
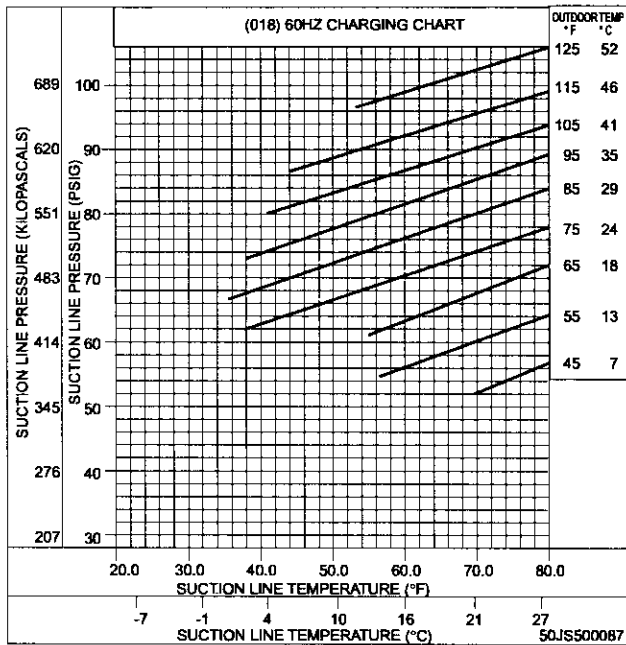

Fig. 26—Cooling Charging Chart, 50JS 018 Units

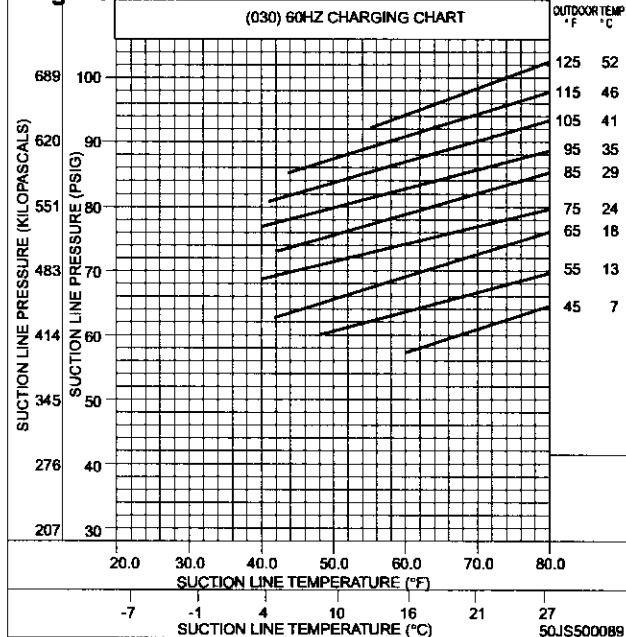

Fig. 28—Cooling Charging Chart, 50JS030

Fig. 27—Cooling Charging Chart, 50JS 024 Units

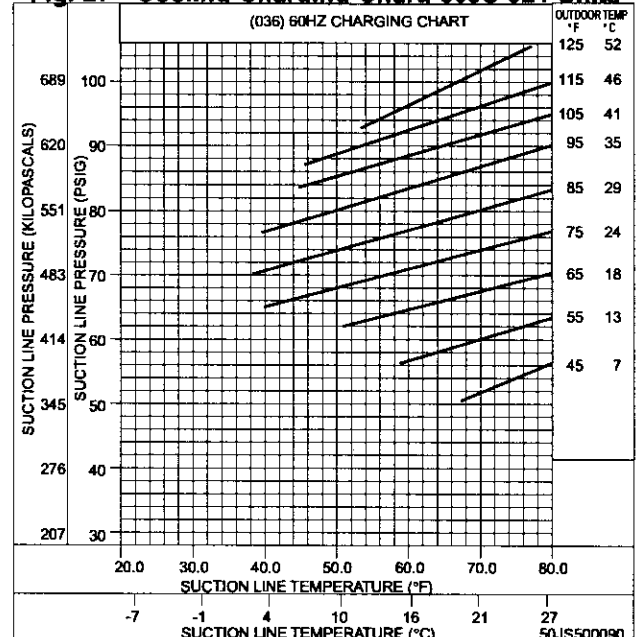

Fig. 29—Cooling Charging Chart, 50JS 036 Units

Step 4—Outdoor fan

⚠ CAUTION

Keep the condenser fan free from all obstructions to ensure proper cooling operation. Never place articles on top of the unit. Damage to unit may result.

1. Inspect the fan blades for cracks or bends.
2. If fan needs to be removed, remove screws holding outdoor air intake grille and remove grille.
3. Loosen the setscrew and slide the fan off the motor shaft.
4. When replacing fan blade, position blade so that the hub is 1/8 in. (See Fig. 21) away from the motor end (1/8 in. of motor shaft will be visible).

5. Ensure that setscrew engages the flat area on the motor shaft when tightening.

6. Replace grille.

Step 5—Electrical controls and wiring

Inspect and check the electrical controls and wiring annually. *Be sure to turn off the electrical power to the unit and install lockout tag.*

Remove access panel to locate all the electrical controls and wiring. Check all electrical connections for tightness. Tighten all screw connections. If any smoky or burned connections are noticed, disassemble the connection, clean all the parts, restrip the wire end and reassemble the connection properly and securely.

After inspecting the electrical controls and wiring, replace all the panels. Start the unit, and observe at least one complete cooling

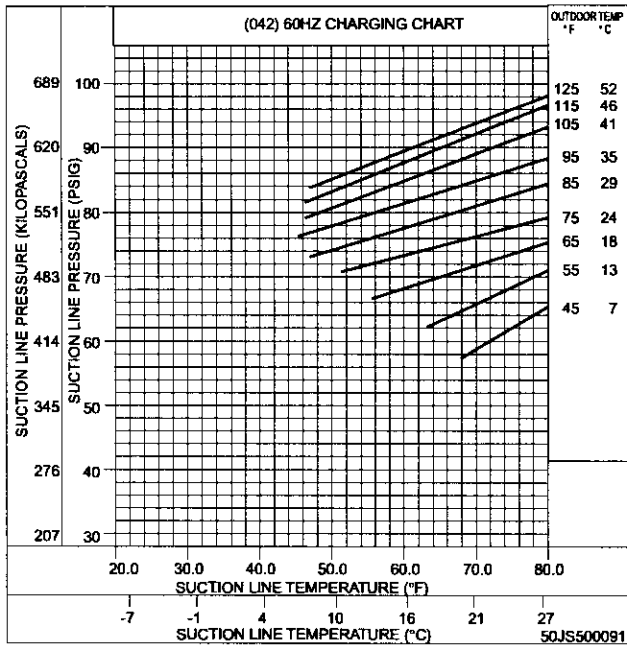

Fig. 30—Cooling Charging Chart, 50JS 042 Units ^{C00030}

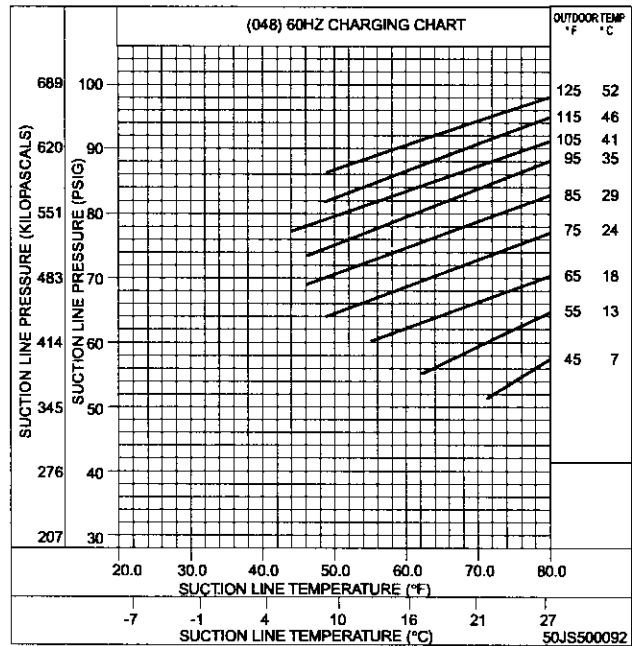

Fig. 31—Cooling Charging Chart, 50JS 048 Units ^{C00031}

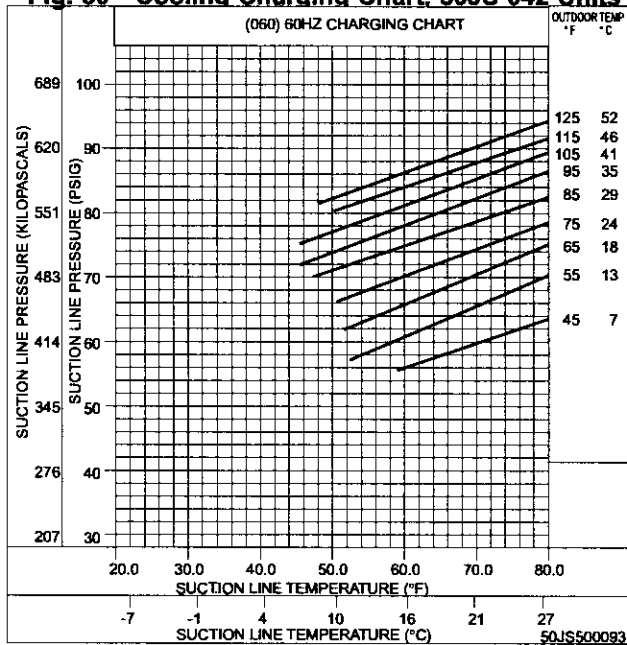

Fig. 32—Cooling Charging Chart, 50JS 060 Units ^{C00032}

Table 9—FILTER PRESSURE DROP (In. wg)

FILTER SIZE	CFM																		
	500	600	700	800	900	1000	1100	1200	1300	1400	1500	1600	1700	1800	1900	2000	2100	2200	2300
20 X 20 X 1	0.05	0.07	0.08	0.10	0.12	0.13	0.14	0.15	—	—	—	—	—	—	—	—	—	—	—
20 X 24 X 1	—	—	—	—	0.09	0.10	0.11	0.13	0.14	0.15	0.16	—	—	—	—	—	—	—	—
24 X 30 X 1	—	—	—	—	—	—	—	0.07	0.08	0.09	0.10	0.11	0.12	0.13	0.14	0.15	0.16	0.17	0.18

cycle to ensure proper operation. If discrepancies are observed in operating cycle, or if a suspected malfunction has occurred, check each electrical component with the proper electrical instrumentation. Refer to the unit wiring label when making these checkouts.

NOTE: Refer to the Sequence of Operation section as an aid in determining proper control operation.

Step 6—Refrigerant circuit

Inspect all refrigerant tubing connections and the unit base for oil accumulation annually. Detecting oil generally indicates a refrigerant leak.

Table 10—ELECTRIC HEAT PRESSURE DROP TABLE
Small Cabinet

STATIC	CFM														
	500	600	700	800	900	1000	1100	1200	1300	1400	1500	1600			
5 kw	0.00	0.00	0.00	0.00	0.00	0.00	0.00	0.00	0.02	0.04	0.06	0.07	0.09	0.10	0.11
10 kw	0.00	0.00	0.00	0.00	0.00	0.00	0.00	0.02	0.04	0.06	0.08	0.10	0.12	0.14	0.16
15 kw	0.00	0.00	0.00	0.02	0.04	0.06	0.08	0.09	0.11	0.13	0.15	0.17	0.19		
20 kw	0.00	0.00	0.02	0.04	0.06	0.08	0.09	0.11	0.13	0.15	0.17	0.19			

Large Cabinet

STATIC	CFM														
	1100	1200	1300	1400	1500	1600	1700	1800	1900	2000	2100	2200	2300	2400	2500
5 kw	0.00	0.00	0.00	0.01	0.02	0.03	0.04	0.05	0.06	0.07	0.08	0.09	0.10	0.11	0.12
10 kw	0.00	0.00	0.01	0.02	0.03	0.04	0.05	0.06	0.07	0.08	0.09	0.10	0.11	0.12	0.13
15 kw	0.00	0.02	0.03	0.04	0.05	0.06	0.07	0.08	0.09	0.10	0.11	0.12	0.13	0.14	0.15
20 kw	0.02	0.03	0.04	0.05	0.06	0.07	0.08	0.09	0.10	0.11	0.12	0.13	0.14	0.15	0.16

⚠ WARNING

System under pressure. Relieve pressure and recover all refrigerant before system repair or final unit disposal to avoid serious injury or death. Use all service ports and open all flow-control devices, including solenoid valves.

If oil is detected or if low performance is suspected, leak-test all refrigerant tubing using an electronic leak detector, or liquid-soap solution. If a refrigerant leak is detected, refer to Check for Refrigerant Leaks section.

If no refrigerant leaks are found and low performance is suspected, refer to Checking and Adjusting Refrigerant Charge section.

Step 7—Indoor airflow

The indoor airflow does not require checking unless improper performance is suspected. *If a problem exists, be sure that all supply- and return-air grilles are open and free from obstructions, and that the air filter is clean.* When necessary, refer to Indoor Airflow and Airflow Adjustments section to check the system airflow.

Step 8—Metering device

Refrigerant metering devices are fixed orifices and are located in the inlet header to the indoor and outdoor coils.

Step 9—Liquid line strainers

The liquid line strainers (to protect metering drives) are made of wire mesh and are located in the liquid lines on the inlet side of the metering devices.

Step 10—High Flow Valves

High flow valves are located on the compressor hot gas and suction tubes. Large black plastic caps distinguish these valves with O-rings located inside the caps. These valves can not be accessed for service in the field. Ensure the plastic caps are in place and tight or the possibility of refrigerant leakage could occur.

Step 11—Time-delay relay

The Time-Delay Relay (TDR) is a solid-state control, recycle delay timer which keeps indoor blower operating for 60 sec. after thermostat is satisfied. This delay enables blower to remove residual cooling in coil after compression shutdown, thereby improving efficiency of system. The sequence of operation is that on closure of wall thermostat and at end of a fixed on delay of 1

sec., fan relay is energized. When thermostat is satisfied, an off delay is initiated. When fixed delay of 60± 5 sec. is completed, fan relay is de-energized and fan motor stops. If wall thermostat closes during this delay, TDR is reset and fan relay remains energized. TDR is a 24-v device that operates within a range of 15-v to 30-v and draws about 0.5 amps. If the blower runs continuously instead of cycling off when the fan switch is set on AUTO, the TDR is probably defective and must be replaced.

Step 12—Loss of charge switch

The loss of charge switch is located on the outdoor liquid line. This switch contains a Schrader core depressor. This switch opens at 7 psig and closes at 22 psig. No adjustment is necessary.

NOTE: Because these switches are attached to refrigeration system under pressure, it is not advisable to remove this device for troubleshooting unless you are reasonably certain that a problem exists. If switch must be removed, remove and recover all system charge so that pressure gages read 0 psi. Never open system without breaking vacuum with dry nitrogen.

Step 13—Check defrost thermostat

There is a liquid header with a brass distributor and feeder tube going into outdoor coil. At the end of 1 of the feeder tubes, there is a 3/8-in. OD stub tube approximately 3 in. long (See Fig. 40). The defrost thermostat should be located on this stub tube. Note that there is only 1 stub tube used with liquid header, and on most units it is the bottom circuit.

Step 14—Defrost Thermostat

Defrost thermostat signals heat pump that conditions are right for defrost or that conditions have changed to terminate defrost. It is a thermally actuated switch clamped to outdoor coil to sense its temperature. Normal temperature range is closed at 30° +/- 3°F and open at 80° +/- 5°F.

NOTE: The defrost thermostat must be located on the liquid side of the outdoor coil on the bottom circuit and as close to the coil as possible.

TROUBLESHOOTING

Refer to the Cooling and Heating Troubleshooting Chart (Table 11) for troubleshooting information.

START-UP CHECKLIST

Use the Start-Up Checklist to ensure proper start-up procedures are followed.

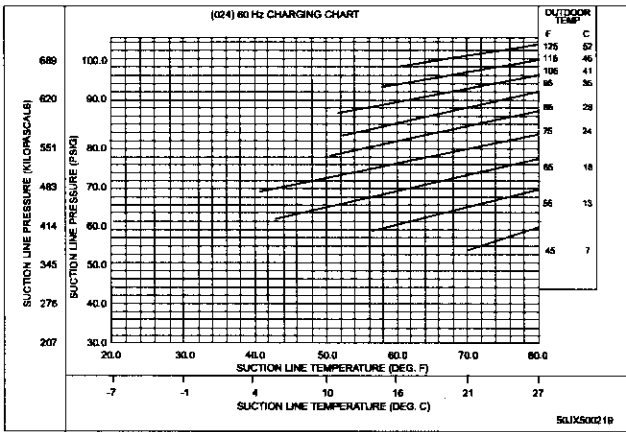

Fig. 33—Cooling Charging Chart, 50JX 024 Units ^{C99031}

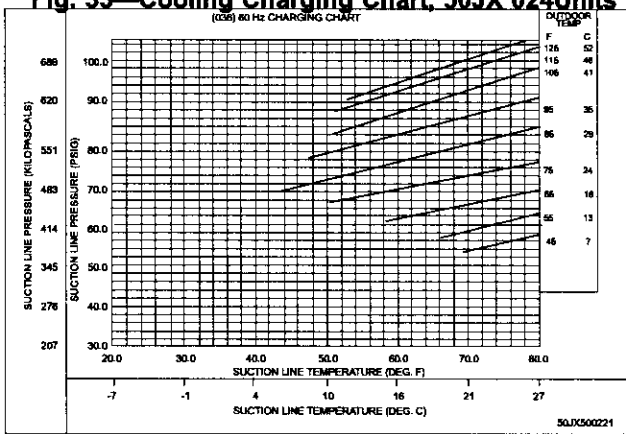

Fig. 35—Cooling Charging Chart, 50JX 036 Units ^{C99033}

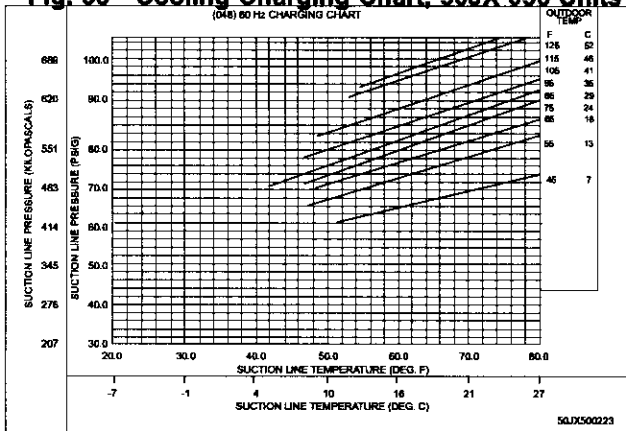

Fig. 37—Cooling Charging Chart, 50JX 048 Units ^{C99035}

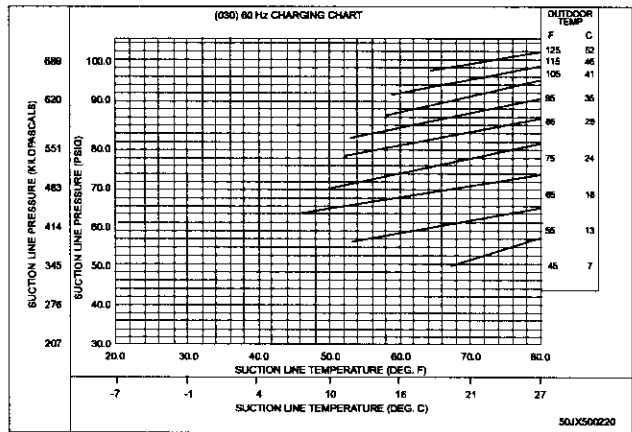

Fig. 34—Cooling Charging Chart, 50JX 030 Units ^{C99032}

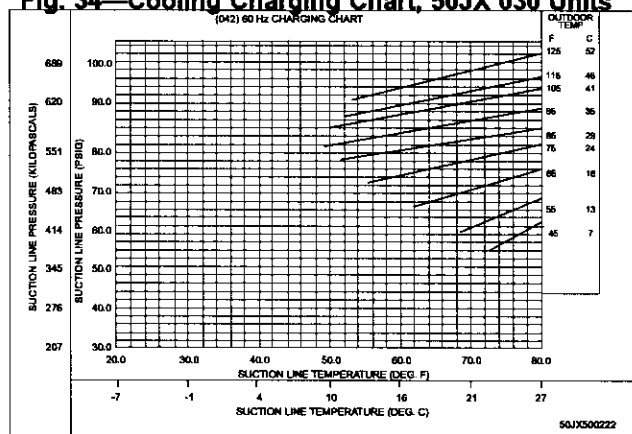

Fig. 36—Cooling Charging Chart, 50JX 042 Units ^{C99034}

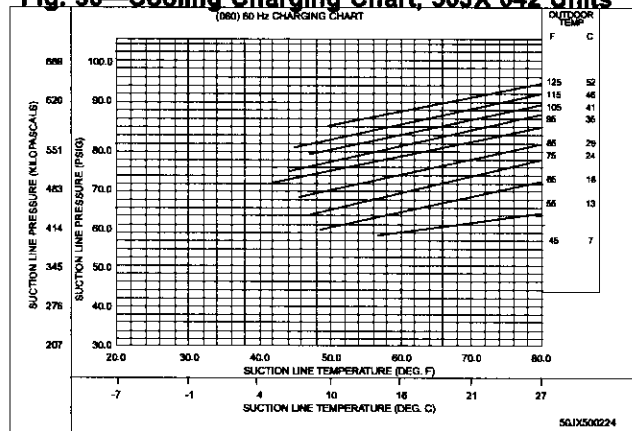

Fig. 38—Cooling Charging Chart, 50JX 060 Units ^{C99036}

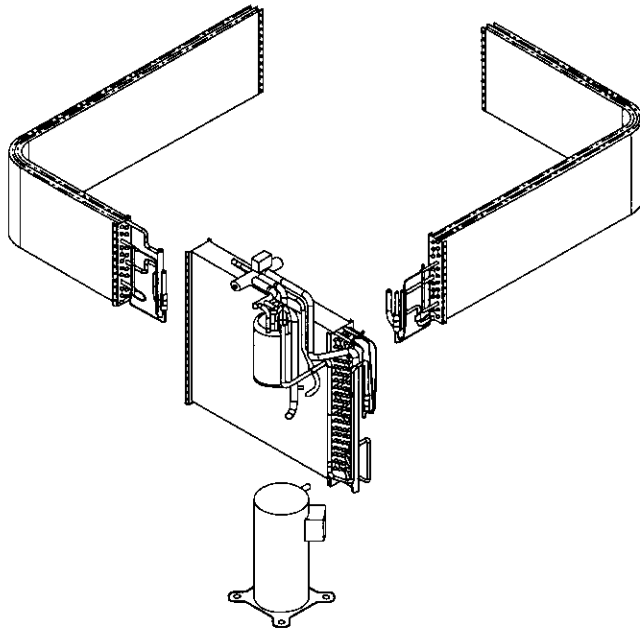

Fig. 39—Refrigerant Circuit

C99097

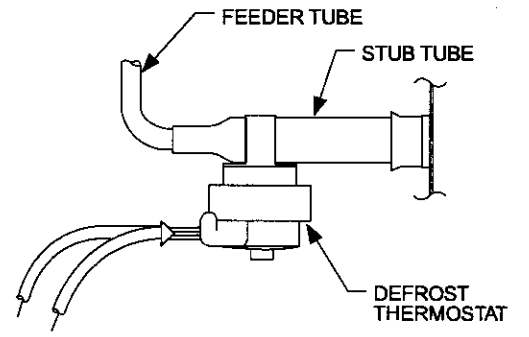

Fig. 40—Defrost Thermostat

C99092

Table 11—Cooling and Heating Troubleshooting Chart

SYMPTOM	CAUSE	REMEDY
Compressor and outdoor fan will not start	Power Failure	Call power company
	Fuse blown or circuit breaker tripped	Replace fuse or reset circuit breaker
	Defective thermostat, contractor, transformer, control relay or defrost board	Replace component
	Insufficient line voltage	Determine cause and correct
	Incorrect or faulty wiring	Check wiring diagram and rewire correctly
	Thermostat setting too high	Lower thermostat setting below room temperature
Compressor will not start but condenser fan runs	Units have a 5-minute time delay	DO NOT bypass this compressor time delay-wait for 5 minute until time-delay relay is de-energized
	Faulty wiring or loose connections in compressor circuit	Check wiring and repair or replace
	Compressor motor burned out, seized, or internal overload open	Determine cause. Replace compressor
	Defective run capacitor, overload, or PTC (positive temperature coefficient) thermistor	Determine cause and replace
	Defective run capacitor, overload, or PTC (positive temperature coefficient) thermistor	Determine cause and replace
Three-phase scroll compressor (size 030-060 units) makes excessive noise, and there may be a low pressure differential	One leg of 3-phase power dead	Replace fuse or reset circuit breaker Determine cause
	Scroll compressor is rotating in the wrong direction	Correct the direction of rotation by reversing the 3-phase power leads to the unit
Compressor cycles (other than normally satisfying thermostat)	Refrigerant overcharge or undercharge	Recover refrigerant, evacuate system, and recharge to capacities shown on nameplate
	Defective compressor	Replace and determine cause
	Insufficient line voltage	Determine cause and correct
	Blocked outdoor coil	Determine cause and correct
	Defective run/start capacitor, overload or start relay	Determine cause and replace
	Defective thermostat	Replace thermostat
	Faulty outdoor-fan motor or capacitor	Replace
	Damaged reversing valve	Determine cause and correct
Compressor operates continuously	Restriction in refrigerant system	Locate restriction and remove
	Dirty air filter	Replace filter
	Unit undersized for load	Decrease load or increase unit size
	Thermostat set too low	Reset thermostat
	Low refrigerant charge	Locate leak, repair, and recharge
	Leaking valves in compressor	Replace compressor
	Frosted coil with incorrect defrost operation	Check defrost time settings Reset as necessary Check defrost temperature switch Replace as necessary
	Air in system	Recover refrigerant, evacuate system, and recharge
Excessive head pressure	Outdoor coil dirty or restricted	Clean coil or remove restriction
	Dirty air filter	Replace filter
	Dirty indoor or outdoor coil	Clean coil
	Refrigerant overcharged	Recover excess refrigerant
	Air in system	Recover refrigerant, evacuate system, and recharge
	(Heat) Indoor air restricted or recirculating	Determine cause and correct
Head pressure too low	Indoor or outdoor air restricted or air short-cycling	Determine cause and correct
	Low refrigerant charge	Check for leaks, repair and recharge
	Compressor valves leaking	Replace compressor
Excessive suction pressure	Restriction in liquid tube	Remove restriction
	(Heat) Outdoor coil frosted	Move timer on control board to 30 minute between defrost cycles
	(Cool) High Heat load	Check for source and eliminate
	Compressor valves leaking	Replace compressor
	Reversing valve hung up or leaking internally	Replace valve
	Refrigerant overcharged	Recover excess refrigerant

(Continued next page)

Table 11—Cooling and Heating Troubleshooting Chart (Cont'd)

SYMPTOM	CAUSE	REMEDY
Suction pressure too low	(Cool) Dirty air filter	Replace filter
	(Heat) Outdoor coil frosted	Move timer on control board to 30 minute between defrost cycles
	Low refrigerant charge	Check for leaks, repair and recharge
	Metering device or low side restricted	Remove source of restriction
	(Cool) Insufficient coil airflow	Increase air quantity Check filter—replace if necessary
	(Cool) Temperature too low in conditioned area	Reset thermostat
	(Cool) Outdoor ambient below 40° F	Install low-ambient kit
	Field-installed filter-drier restricted	Replace
Compressor runs but outdoor fan does not	NC (normally closed) contacts on defrost board open	Check condition of relay on board Replace if necessary
IFM* does not run	Blower wheel not secured to shaft	Properly tighten blower wheel to shaft
	Insufficient voltage at motor	Determine cause and correct
	Power connectors not properly sealed	Connectors should snap easily; do not force
IFM* runs when it should be off	Motor programmed with a delay profile	Allow a few minute for motor to shut off
	With thermostat in off state, the voltage on G, Y1, Y, Y2, W with respect to common, should be 1/2 of actual low voltage supply	If measured voltage is more than 1/2, the thermostat is incompatible with motor If voltage is less than 1/2, the motor has failed
IFM* operation is intermittent	Water dripping into motor	Verify proper drip loops in connector wires
	Connectors not firmly sealed	Gently pull wires individually to be sure they are crimped into the housing

* IFM—Indoor Fan Motor

**Start-up checklist
(REMOVE AND STORE IN JOB FILE)**

I. PRELIMINARY INFORMATION

Model No
 Serial No
 Date
 Technician
 Job Location

II. PRE-START-UP

- ___ Verify that all packing materials have been removed from unit
- ___ Remove all shipping holddown bolts and brackets per installation instructions
- ___ Verify that condensate connection is installed per installation instructions
- ___ Check all electrical connections and terminals for tightness
- ___ Check that indoor (evaporator) air filter is clean and in place
- ___ Verify that unit installation is level
- ___ Check fan wheel propeller for location in housing and setscrew tightness

III. START-UP

Supply Voltage: L1-L2 _____ L2-L3 _____ L3-L1 _____
 Compressor Amps: L1 _____ L2 _____ L3 _____
 Indoor Fan Amps: _____

TEMPERATURE

Outdoor-Air Temperature: _____ DB
 Return-Air Temperature: _____ DB _____ WB
 Heat Pump Supply Air: _____
 Electric Heater Supply Air: _____

PRESSURES

Refrigerant Suction _____ psig
 Refrigerant Discharge _____ psig

___ Verify Refrigerant charge using charging tables
 ___ Verify that 3-phase scroll compressor is rotating in correct direction

Manufacturer reserves the right to discontinue, or change at any time, specifications or designs without notice and without incurring obligations.