

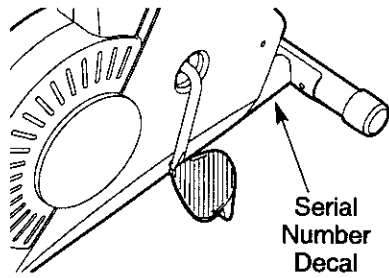

# 310 CS

Model No. 831.283101  
Serial No. \_\_\_\_\_



- Assembly
- Operation
- Maintenance
- Part List and Drawing

## **CAUTION**

Read all precautions and instructions in this manual before using this equipment. Keep this manual for future reference.

## **BIKE EXERCISER User's Manual**

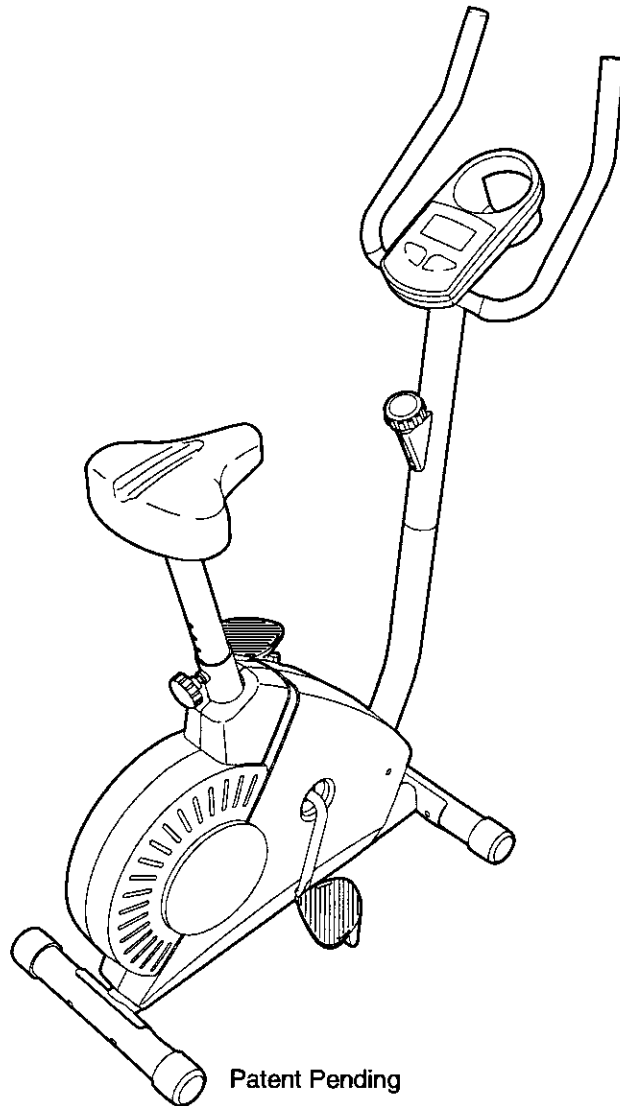

Sears, Roebuck and Co., Hoffman Estates, IL 60179

---

# TABLE OF CONTENTS

IMPORTANT PRECAUTIONS	2
BEFORE YOU BEGIN	3
ASSEMBLY	4
HOW TO OPERATE THE EXERCISE CYCLE	8
MAINTENANCE AND TROUBLESHOOTING	10
CONDITIONING GUIDELINES	12
PART LIST	14
EXPLODED DRAWING	15
ORDERING REPLACEMENT PARTS	Back Cover
LIMITED WARRANTY	Back Cover

---

## IMPORTANT PRECAUTIONS

**▲ WARNING:** To reduce the risk of serious injury, read the following important precautions before using the exercise cycle.

1. Read all instructions in this manual before using the exercise cycle.
2. Use the exercise cycle only as described in this manual.
3. It is the responsibility of the owner to ensure that all users of the exercise cycle are adequately informed of all precautions.
4. Use the exercise cycle indoors on a level surface. Keep the exercise cycle away from moisture and dust. Place a mat under the exercise cycle to protect the floor.
5. Inspect and properly tighten all parts regularly. Replace any worn parts immediately.
6. Keep children under the age of 12 and pets away from the exercise cycle at all times.
7. Wear appropriate clothes when exercising; do not wear loose clothes that could become caught on the exercise cycle. Always wear athletic shoes for foot protection.
8. The exercise cycle should not be used by persons weighing more than 250 pounds.
9. Always keep your back straight while using the exercise cycle; do not arch your back.
10. If you feel pain or dizziness while exercising, stop immediately and cool down.
11. The exercise cycle does not have a free wheel; the pedals will continue to move until the flywheel stops.
12. The exercise cycle is intended for home use only. Do not use the exercise cycle in a commercial, rental, or institutional setting.

**▲ WARNING:** Before beginning this or any exercise program, consult your physician. This is especially important for persons over the age of 35 or persons with pre-existing health problems. Read all instructions before using. SEARS assumes no responsibility for personal injury or property damage sustained by or through the use of this product.

## BEFORE YOU BEGIN

Congratulations for selecting the new WESLO® PURSUIT 310 CS exercise cycle. Cycling is one of the most effective exercises for increasing cardiovascular fitness, building endurance, and toning the body. The PURSUIT 310 CS exercise cycle offers a selection of features designed to let you enjoy this healthful exercise in the convenience and privacy of your home.

**For your benefit, read this manual carefully before you use the exercise cycle.** If you have questions after reading the manual, please call 1-800-4-MY-

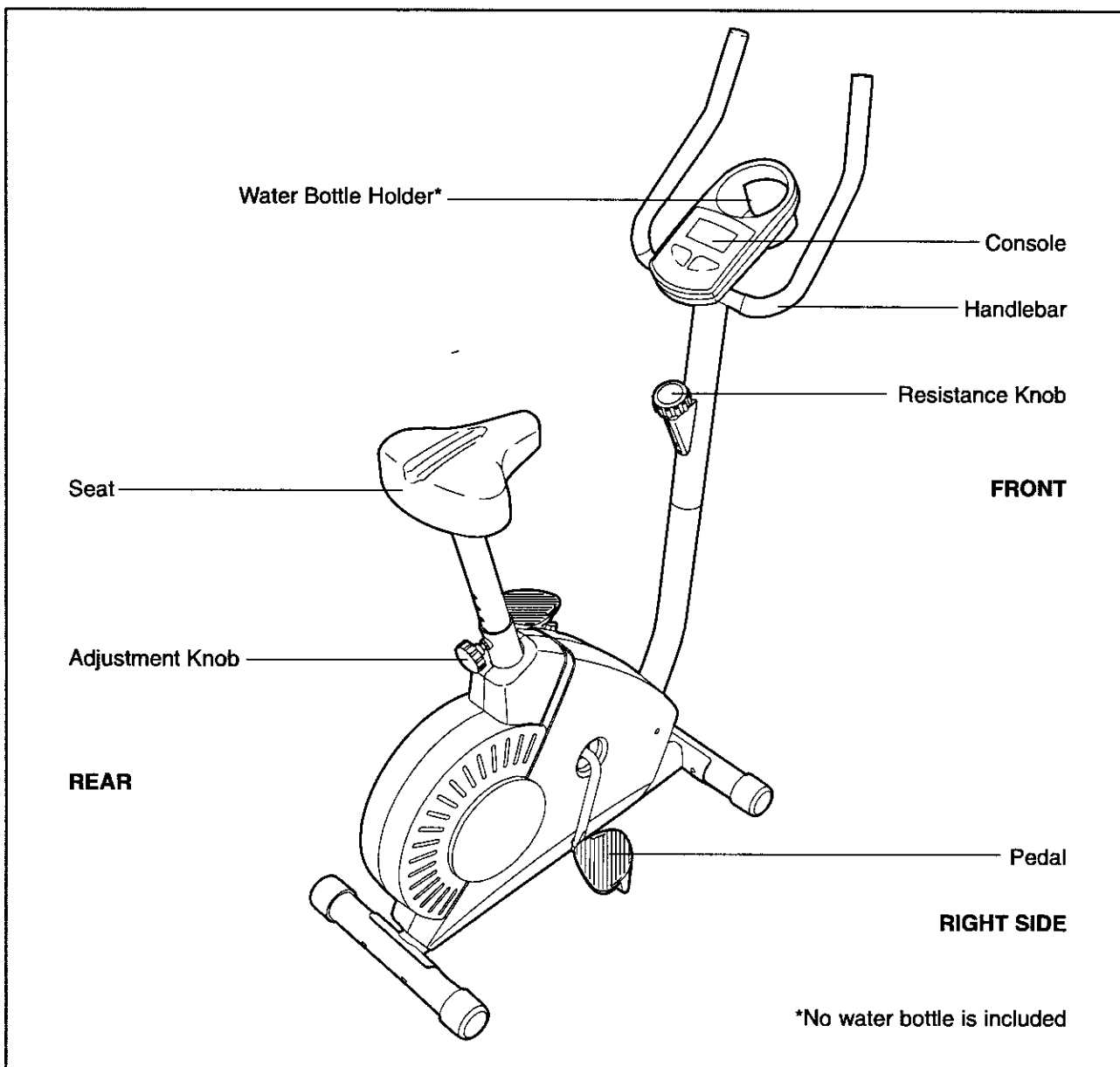

HOME® (1-800-469-4663). To help us assist you, please note the product model number and serial number before calling. The model number is 831.283101. The serial number can be found on a decal attached to the exercise cycle (see the front cover of this manual for the location of the decal).

Before reading further, please familiarize yourself with the parts that are labeled in the drawing below.



# ASSEMBLY

**Assembly requires two persons.** Place all parts of the exercise cycle in a cleared area and remove the packing materials. Do not dispose of the packing materials until assembly is completed.

**Assembly requires the included tools and your own adjustable wrench  , Phillips screwdriver  , and pliers  .**

Use the part drawings below to identify the small parts used in assembly. The number in parenthesis below each drawing refers to the key number of the part, from the PART LIST on page 14. The second number refers to the quantity needed for assembly. **Note: Some small parts may have been pre-attached for shipping. If a part is not in the parts bag, check to see if it has been pre-attached.**

**Note:** If a part is not in the parts bag, first check to see if it has been pre-assembled. **If a part is missing, call toll-free 1-800-999-3756.**

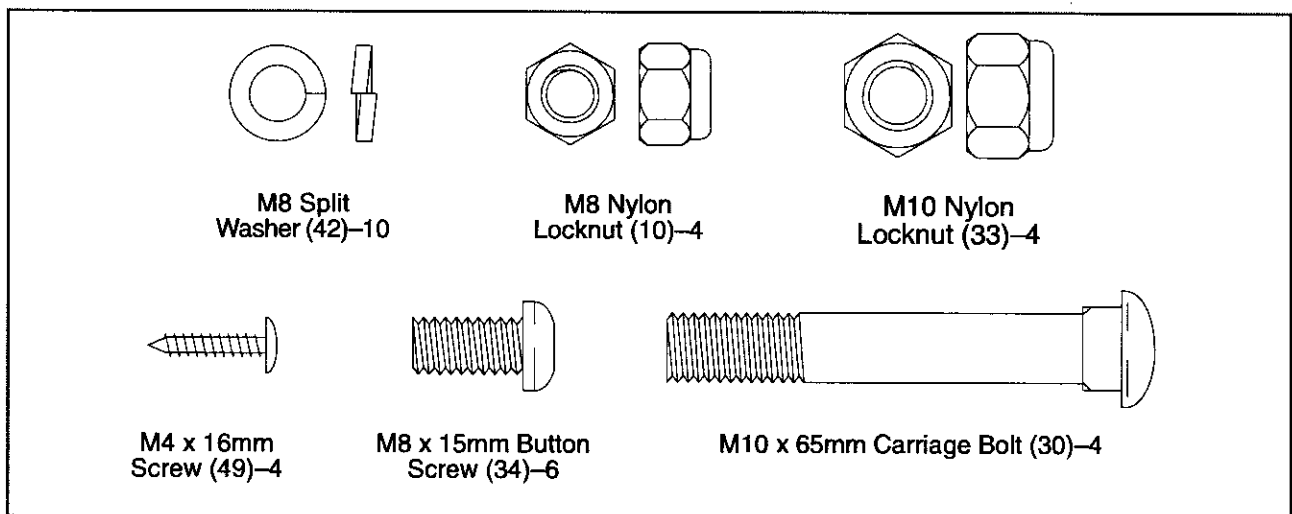

1. While another person lifts the front of the Frame (1) slightly, attach a Stabilizer (2) with two M10 x 65mm Carriage Bolts (30) and two M10 Nylon Locknuts (33).

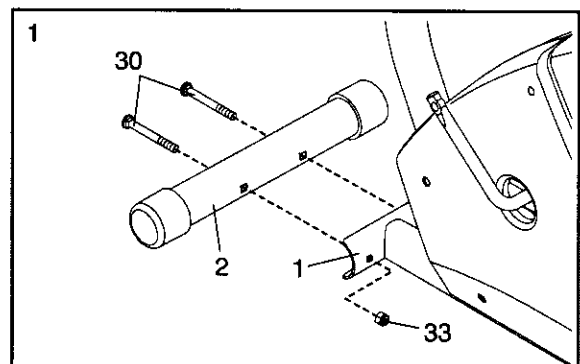

2. While another person lifts the rear of the Frame (1) slightly, attach a Stabilizer (2) with two M10 x 65mm Carriage Bolts (30) and two M10 Nylon Locknuts (33).

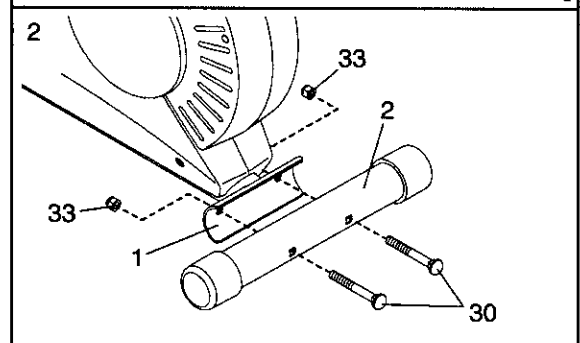

3. The Console (16) requires three AA batteries; alkaline batteries are recommended. Insert three batteries into the battery compartment. **Make sure that the batteries are oriented as shown by the markings inside the battery compartment.**

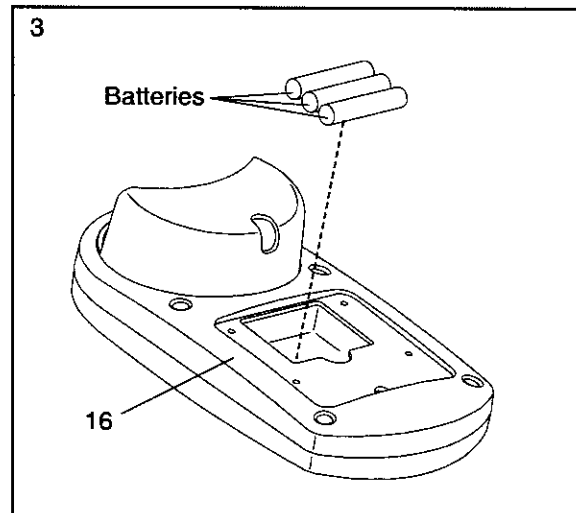

4. Hold the Console (16) near the Handlebar (15). Insert the console wire into the indicated hole in the Handlebar. Note: The console wire is longer than shown.

Attach the Console (16) to the Handlebar (15) with four M4 x 16mm Screws (49). **Be careful to avoid pinching the console wire.**

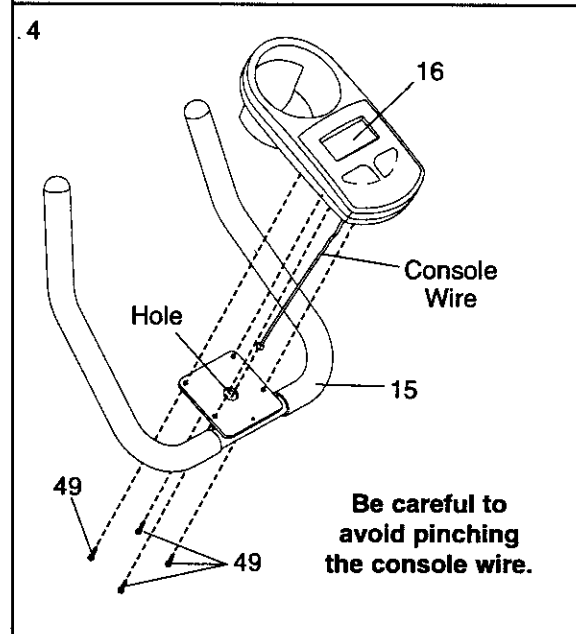

5. While another person holds the Handlebar (15) near the Upright (13), insert the console wire down through the Upright. Attach the Handlebar to the Upright with three M8 x 15mm Button Screws (34) and three M8 Split Washers (42). **Be careful to avoid pinching the console wire.** Note: The console wire is longer than shown.

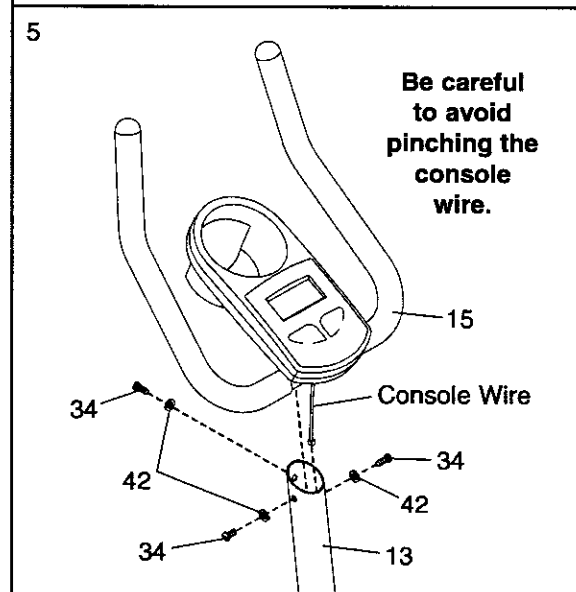

6. While another person holds the Upright (13) in the position shown, connect the console wire to the Reed Switch Wire (43). Next, connect the Resistance Cable (19) to the Lower Cable (45) in the following way:

- See drawing A. Pull up on the metal bracket on the Lower Cable (45), and insert the tip of the Resistance Cable (19) into the wire clip inside the metal bracket as shown.
- See drawing B. Firmly pull up the Resistance Cable (19) and slide it into the top of the metal bracket as shown.
- See drawing C. Using pliers, squeeze the prongs on the upper end of the metal bracket together.

Push the excess Cable (19, 45) and the excess console wire down into the Frame (1), and insert the Upright into the Frame. **Be careful to avoid pinching the Wires and Cables.** Attach the Upright to the Frame with three M8 x 15mm Button Screws (34) and three M8 Split Washers (42).

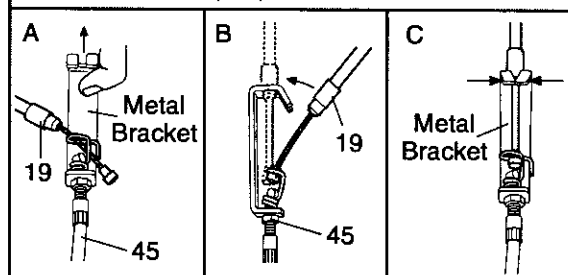
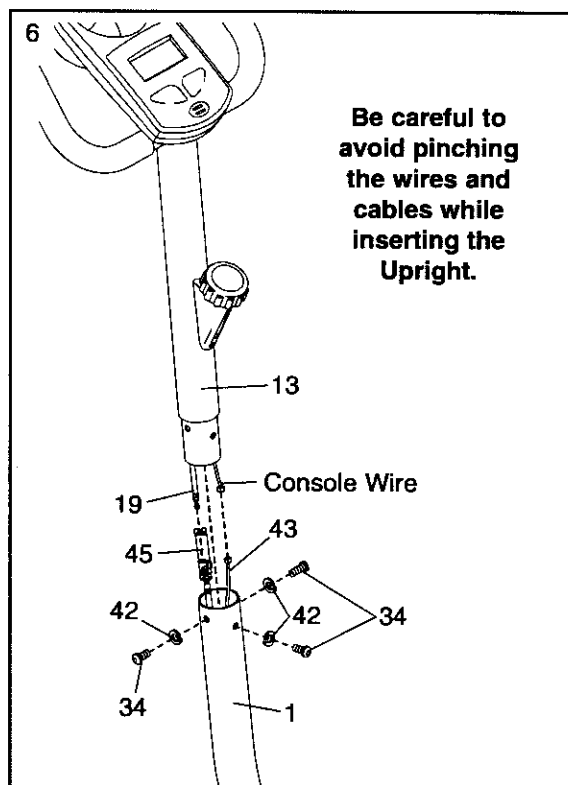

7. Attach the Seat (12) to the Seat Post (5) with four M8 Split Washers (42) and four M8 Nylon Locknuts (10). Note: The Split Washers and Nylon Locknuts may be preattached to the underside of the Seat.

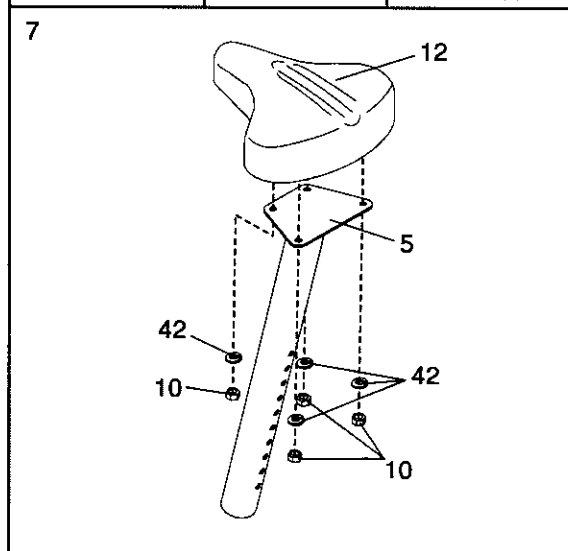

8. Turn the indicated Adjustment Knob (9) counterclockwise and remove it. Insert the Seat Post (5) into the Frame (1). Align one of the adjustment holes in the Seat Post with the indicated hole in the Frame. Insert the Adjustment Knob into the Frame and the Seat Post, and turn the Knob clockwise until it is tight. **Make sure that the Knob is inserted through one of the adjustment holes in the Seat Post.**

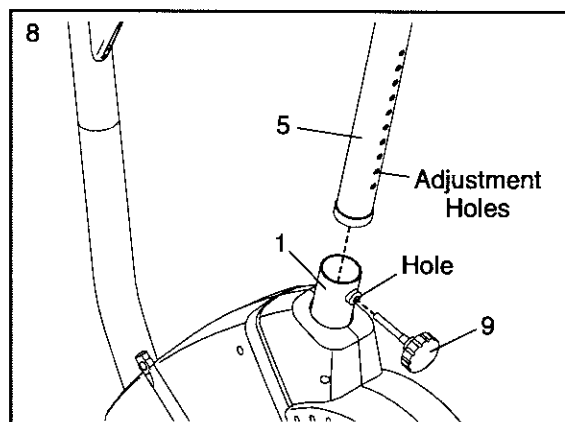

9. Identify the Left Pedal (24), which is marked with an "L." Using an adjustable wrench, **firmly tighten** the Left Pedal *counterclockwise* into the left arm of the Crank (21). Tighten the Right Pedal (not shown) *clockwise* into the right arm of the Crank. **Important: Tighten both Pedals as firmly as possible. After using the exercise cycle for one week, retighten the Pedals. For best performance, the Pedals must be kept tightened.**

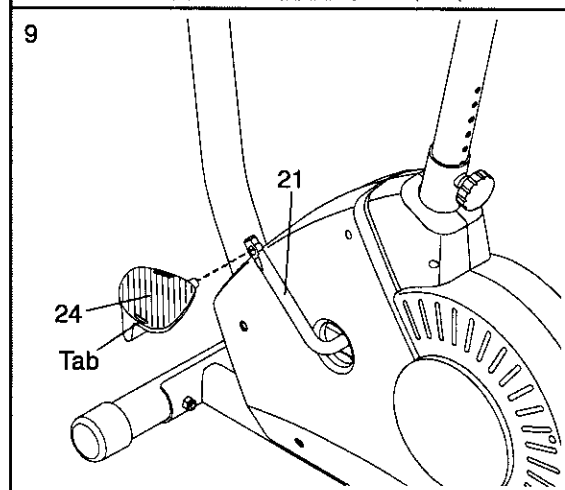

10. **Make sure that all parts are properly tightened before you use the exercise cycle.** Note: After assembly is completed, some extra parts may be left over. Place a mat beneath the exercise cycle to protect the floor.

# HOW TO OPERATE THE EXERCISE CYCLE

## HOW TO ADJUST THE SEAT POST

For effective exercise, the seat should be at the proper height. As you pedal, there should be a slight bend in your knees when the pedals are in the lowest position. To adjust the height of the seat, first turn the indicated knob counterclockwise and remove it.

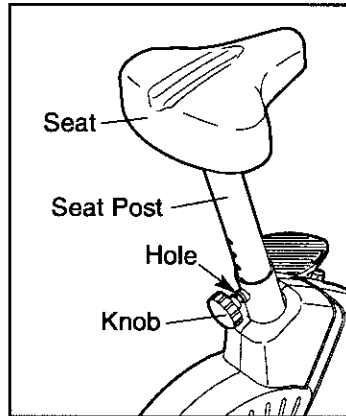

Next, slide the seat post up or down and align one of the adjustment holes in the seat post with the indicated hole in the Frame. Insert the knob into the frame and the seat post, and turn the knob clockwise until it is tight. **Make sure that the knob is inserted through one of the adjustment holes in the seat post.**

## HOW TO ADJUST THE PEDALING RESISTANCE

To increase the resistance of the pedals, turn the resistance knob clockwise; to decrease the resistance, turn the knob counterclockwise. **Important: Stop turning the knob when turning becomes difficult, or damage may result.**

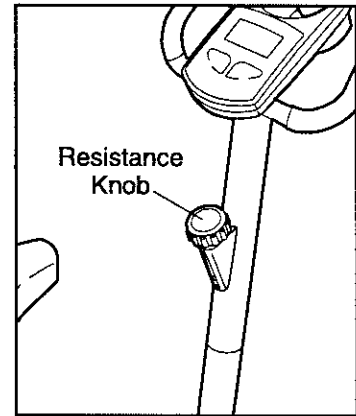



## FEATURES OF THE CONSOLE

The easy-to-use console features five modes that provide instant exercise feedback during your workouts. The modes are described below.

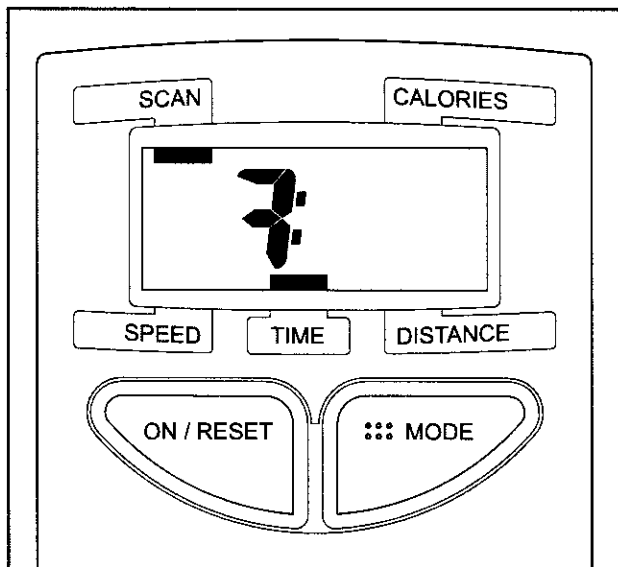

**Speed**—This mode displays your pedaling speed, in miles per hour or kilometers per hour.

**Time**—This mode displays the elapsed time. Note: If you stop pedaling for a few seconds, the time mode will pause.

**Distance**—This mode displays the distance you have pedaled, in miles or kilometers.

**Calorie**—This mode displays the approximate number of calories you have burned.

**Scan**—This mode displays the speed, time, distance, and calorie modes, for a few seconds each, in a repeating cycle.

## HOW TO OPERATE THE CONSOLE

Make sure there are batteries in the console (see BATTERY REPLACEMENT on page 10). If there is a thin sheet of clear plastic on the console, remove it.

Follow the steps below to operate the console.

1. To turn on the power, press the On/Reset button or begin pedaling. The entire display will briefly appear; the console will then be ready for use.

2. Select one of the modes:

**Scan mode**—When the power is turned on, the scan mode will be selected automatically. A mode indicator will appear below the word “SCAN” to show that the scan mode is selected, and a second mode indicator will show which mode is currently displayed. Note: If you have selected a different mode, repeatedly press the Mode button to reselect the scan mode.

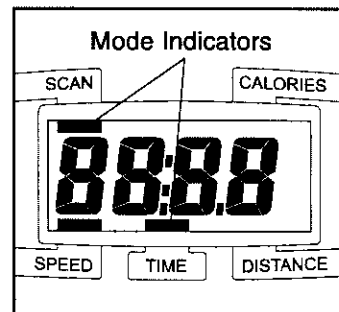

**Speed, time, distance, or calorie mode**—To select one of these modes for continuous display, repeatedly press the Mode button. The mode indicators will show which mode is selected. Make sure there is not a mode indicator below the word “SCAN.”

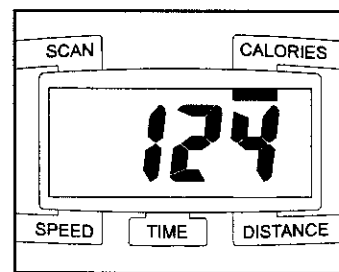

**Note: The console can display speed and distance in either miles or kilometers. To change the unit of measurement, press the On/Reset button for about five seconds.** The letters mph or km/h will appear in the display to show which unit of measurement is selected. When the batteries are replaced, it may be necessary to reselect the desired unit of measurement.

3. To reset the display at any time, press the On/Reset button.
4. To turn off the power, simply wait for a few minutes. **The console has an “auto-off” feature. If the pedals are not moved and the console buttons are not pressed for a few minutes, the power will turn off automatically to save the batteries.**

# MAINTENANCE AND TROUBLESHOOTING

Inspect and tighten all parts of the exercise cycle regularly. Replace any worn parts immediately.

To clean the exercise cycle, use a damp cloth and a small amount of mild detergent. **Important: To avoid damage to the console, keep liquids away from the console and keep the console out of direct sunlight.**

## BATTERY REPLACEMENT

If the console display becomes dim, the batteries should be replaced; most console problems are the result of low batteries. To replace the batteries, refer to step 4 on page 5 and remove the console from the handlebar. Next, refer to step 3 on page 5 and insert three batteries into the console. Reattach the console to the handlebar, being careful not to pinch the wires.

## HOW TO ADJUST THE REED SWITCH

If the console does not display correct feedback, the reed switch should be adjusted. In order to adjust the reed switch, the left side shield must be removed.

Using an adjustable wrench, turn the Left Pedal (24) clockwise and remove it. Next, remove the five M4 x 25mm Screws (41) and the M4 x 16mm Round Head Screw (3) from the Left Side Shield (17). Carefully remove the Left Side Shield.

Next, turn the resistance knob to the lowest setting. With the left side shield removed, locate the Reed Switch (43). Turn the Crank (21) until the Magnet (38) is aligned with the Reed Switch. Loosen, but do not remove, the M4 x 16mm Screw (49). Slide the Reed Switch slightly closer to or away from the Magnet. Retighten the Screw. Turn the Crank for a moment. Repeat until the console displays correct feedback. When the Reed Switch is correctly adjusted, reattach the left side shield and the left pedal.

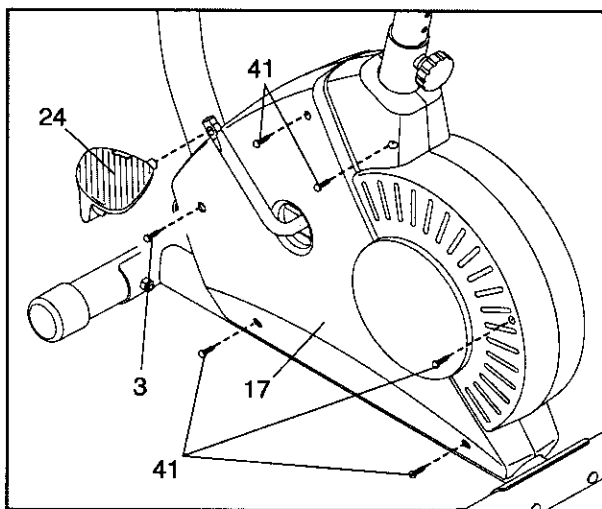
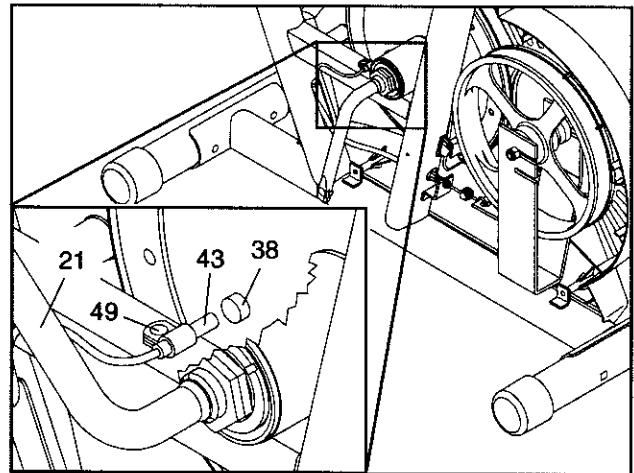

# CONDITIONING GUIDELINES

The following guidelines will help you to plan your exercise program. Remember that proper nutrition and adequate rest are essential for successful results.

**⚠ WARNING:** Before beginning this or any exercise program, consult your physician. This is especially important for persons over the age of 35 or persons with pre-existing health problems.

## EXERCISE INTENSITY

Whether your goal is to burn fat or to strengthen your cardiovascular system, the key to achieving the desired results is to exercise with the proper intensity. The proper intensity level can be found by using your heart rate as a guide. The chart below shows recommended heart rates for fat burning, maximum fat burning, and cardiovascular (aerobic) exercise.

165	155	145	140	130	125	115	♥
145	138	130	125	118	110	103	♥
125	120	115	110	105	95	90	♥
20	30	40	50	60	70	80	

To find the proper heart rate for you, first find your age at the bottom line of the chart (ages are rounded off to the nearest ten years). Next, find the three numbers above your age. The three numbers are your “training zone.” The lowest number is the recommended heart rate for fat burning; the middle number is the recommended heart rate for maximum fat burning; the highest number is the recommended heart rate for aerobic exercise.

### Fat Burning

To burn fat effectively, you must exercise at a relatively low intensity level for a sustained period of time. During the first few minutes of exercise, your body uses easily accessible *carbohydrate* calories for energy. Only after the first few minutes of exercise does your body begin to use stored *fat* calories for energy. If your goal is to burn fat, adjust the intensity of your exercise until your heart rate is near the lowest number in your training zone as you exercise. For maxi-

mum fat burning, adjust the intensity of your exercise until your heart rate is near the middle number in your training zone as you exercise.

### Aerobic Exercise

If your goal is to strengthen your cardiovascular system, your exercise must be “aerobic.” Aerobic exercise is activity that requires large amounts of oxygen for prolonged periods of time. This increases the demand on the heart to pump blood to the muscles, and on the lungs to oxygenate the blood. For aerobic exercise, adjust the intensity of your exercise until your heart rate is near the highest number in your training zone.

## HOW TO MEASURE YOUR HEART RATE

To measure your heart rate, first exercise for at least four minutes. Then, stop exercising and place two fingers on your wrist as shown. Take a six-second heartbeat count, and multiply the result by 10 to find your heart rate. For example, if your six-second heartbeat count is 14, your heart rate is 140 beats per minute. (A six-second count is used because your heart rate will drop rapidly when you stop exercising.)

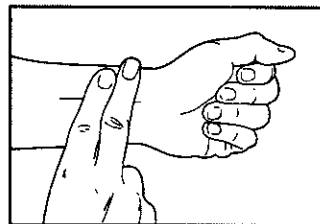

## WORKOUT GUIDELINES

Each workout should include the following three parts:

**A warm-up**, consisting of 5 to 10 minutes of stretching and light exercise. A proper warm-up increases your body temperature, heart rate, and circulation in preparation for exercise.

**Training zone exercise**, consisting of 20 to 30 minutes of exercising with your heart rate in your training zone. Note: During the first few weeks of your exercise program, do not keep your heart rate in your training zone for longer than 20 minutes.

**A cool-down**, with 5 to 10 minutes of stretching. This will increase the flexibility of your muscles and will help to prevent post-exercise problems.

## EXERCISE FREQUENCY

To maintain or improve your condition, plan three workouts each week, with at least one day of rest between

workouts. After a few months of regular exercise, you may complete up to five workouts each week, if desired. Remember, the key to success is make exercise a regular and enjoyable part of your everyday life.

## SUGGESTED STRETCHES

The correct form for several basic stretches is shown at the right. Move slowly as you stretch—never bounce.

### 1. Toe Touch Stretch

Stand with your knees bent slightly and slowly bend forward from your hips. Allow your back and shoulders to relax as you reach down toward your toes as far as possible. Hold for 15 counts, then relax. Repeat 3 times. Stretches: Hamstrings, back of knees and back.

### 2. Hamstring Stretch

Sit with one leg extended. Bring the sole of the opposite foot toward you and rest it against the inner thigh of your extended leg. Reach toward your toes as far as possible. Hold for 15 counts, then relax. Repeat 3 times for each leg. Stretches: Hamstrings, lower back and groin.

### 3. Calf/Achilles Stretch

With one leg in front of the other, reach forward and place your hands against a wall. Keep your back leg straight and your back foot flat on the floor. Bend your front leg, lean forward and move your hips toward the wall. Hold for 15 counts, then relax. Repeat 3 times for each leg. To cause further stretching of the achilles tendons, bend your back leg as well. Stretches: Calves, achilles tendons and ankles.

### 4. Quadriceps Stretch

With one hand against a wall for balance, reach back and grasp one foot with your other hand. Bring your heel as close to your buttocks as possible. Hold for 15 counts, then relax. Repeat 3 times for each leg. Stretches: Quadriceps and hip muscles.

### 5. Inner Thigh Stretch

Sit with the soles of your feet together and your knees outward. Pull your feet toward your groin area as far as possible. Hold for 15 counts, then relax. Repeat 3 times. Stretches: Quadriceps and hip muscles.

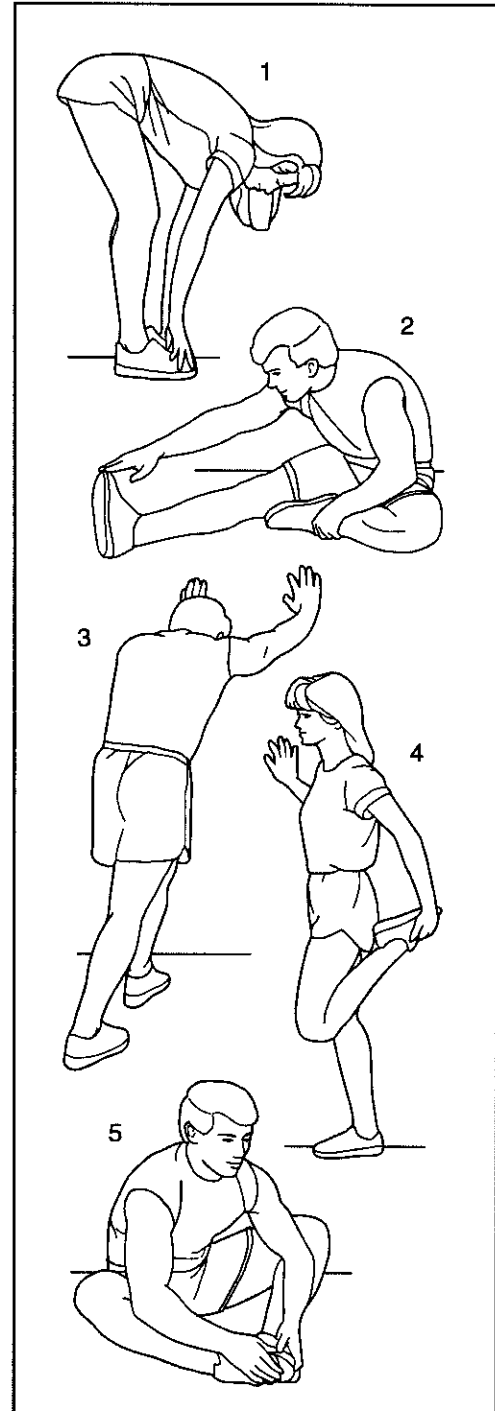

# NOTES

---

# EXPLODED DRAWING—Model No. 831.283101

R0903A

Key No.	Qty.	Description	Key No.	Qty.	Description
1	1	Frame	28	2	U-bracket
2	2	Stabilizer	29	1	Crank Nut
3	2	M4 x 16mm Round Head Screw	30	4	M10 x 65mm Carriage Bolt
4	4	Stabilizer Endcap	31	2	Eyebolt
5	1	Seat Post	32	3	M6 Nut
6	1	C-Magnet Bracket	33	4	M10 Nylon Locknut
7	2	Handlebar Endcap	34	6	M8 x 15mm Button Screw
8	2	Foam Grip	35	1	Belt
9	1	Adjustment Knob	36	1	M4 x 19mm Screw
10	7	M8 Nylon Locknut	37	1	Flywheel
11	1	C-Magnet	38	1	Magnet
12	1	Seat	39	1	Flywheel Axle
13	1	Upright	40	1	6200Z Bearing
14	1	M8 Washer	41	5	M4 x 28mm Round Head Screw
15	1	Handlebar	42	10	M8 Split Washer
16	1	Console	43	1	Reed Switch/Wire
17	1	Left Side Shield	44	1	Crank Bearing Set
18	1	Right Side Shield	45	1	Lower Cable
19	1	Resistance Control/Cable	46	1	Resistance Cable
20	1	Seat Post Bushing	47	1	Return Spring
21	1	Crank/Pulley	48	1	Spring
22	1	Reed Switch Clamp	49	6	M4 x 16mm Screw
23	2	M10 Washer	50	2	M6 Zinc Nut
24	1	Left Pedal	51	1	M6 x 35mm Bolt
25	1	6000Z Bearing	52	1	M8mm x 21mm Bolt
26	1	Right Pedal	#	1	User's Manual
27	1	Resistance Knob	#	2	Allen Wrench

Note: “#” indicates a non-illustrated part. Specifications are subject to change without notice. If a part is missing, call toll-free 1-800-999-3756. See the back cover of this manual for information about ordering replacement parts.

# EXPLODED DRAWING—Model No. 831.283101

R0903A

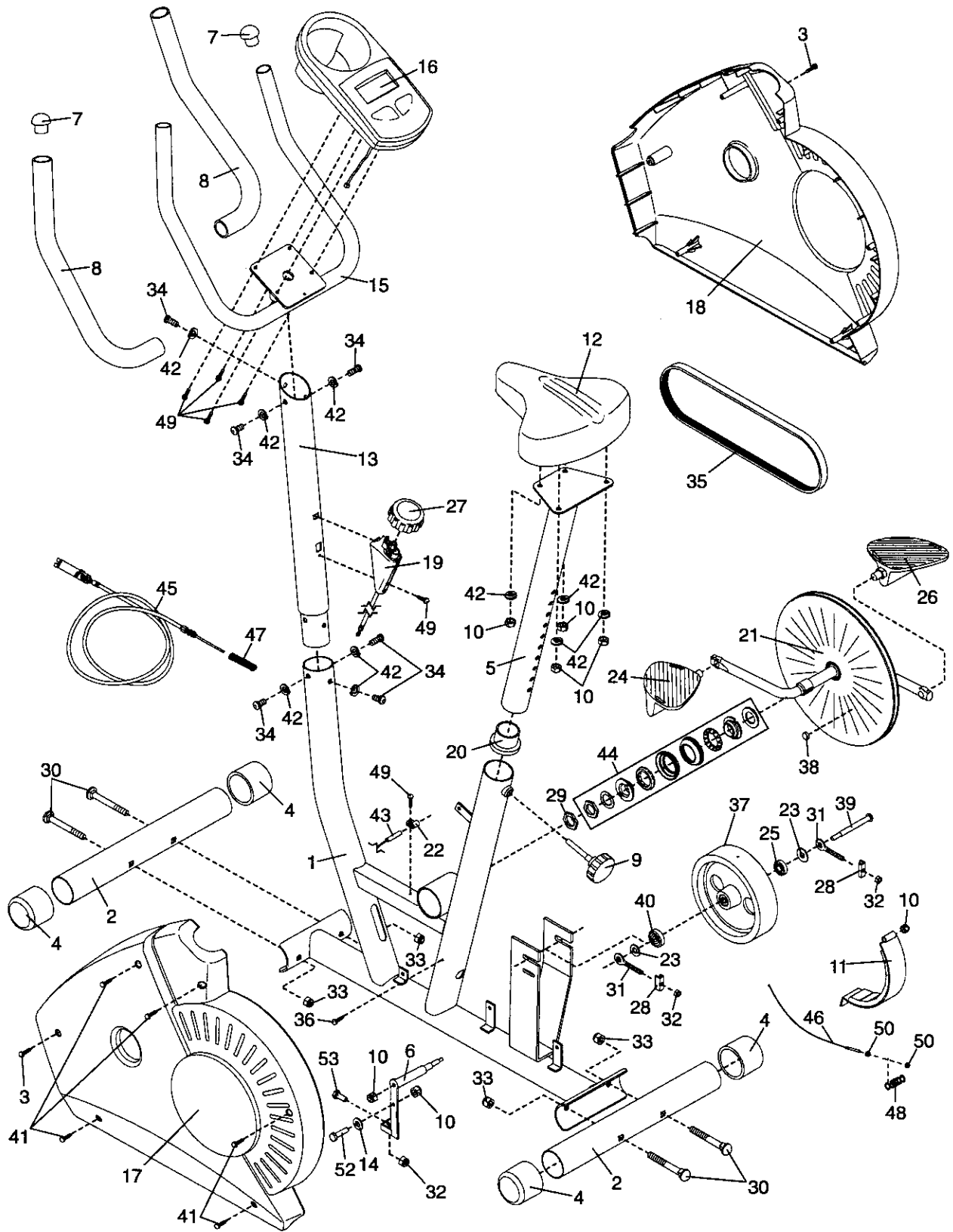

## Get it fixed, at your home or ours!

### Your Home

For repair – **in your home** – of **all** major brand appliances, lawn and garden equipment, or heating and cooling systems, **no matter who made it, no matter who sold it!**

For the replacement parts, accessories, and user's manuals that you need to do-it-yourself.

For Sears professional installation of home appliances and items like garage door openers and water heaters.

**1-800-4-MY-HOME®**

(1-800-469-4663)

[www.sears.com](http://www.sears.com)

Anytime, day or night

(U.S.A. and Canada)

[www.sears.ca](http://www.sears.ca)

### Our Home

For repair of carry-in products like vacuums, lawn equipment, and electronics, call or go on-line for the location of your nearest **Sears Parts and Repair Center.**

**1-800-488-1222** Anytime, day or night (U.S.A. only)

[www.sears.com](http://www.sears.com)

To purchase a protection agreement (U.S.A.) or maintenance agreement (Canada) on a product serviced by Sears:

**1-800-827-6655** (U.S.A.)

**1-800-361-6665** (Canada)

Para pedir servicio de reparación a domicilio, y para ordenar piezas:

**1-888-SU-HOGAR<sup>SM</sup>** (1-888-784-6427)

# SEARS

® Registered Trademark / ™ Trademark / ™ Service Mark of Sears, Roebuck and Co.  
® Marca Registrada / ™ Marca de Fábrica / ™ Marca de Servicio de Sears, Roebuck and Co.

## FULL 90 DAY WARRANTY

For 90 days from the date of purchase, if failure occurs due to defect in material or workmanship in this Sears Bike Exerciser, contact the nearest Sears Service Center throughout the United States and Sears will repair or replace the Bike Exerciser, free of charge.

This warranty does not apply when the Bike Exerciser is used commercially or for rental purposes.

This warranty gives you specific legal rights, and you may also have other rights which vary from state to state.

**Sears, Roebuck and Co., Dept. 817WA, Hoffman Estates, IL 60179**