

Owner's Manual



LAWN TRACTOR

18.5 HP, 42" Mower

Electric Start

Automatic Transmission

Model No.

917.274760

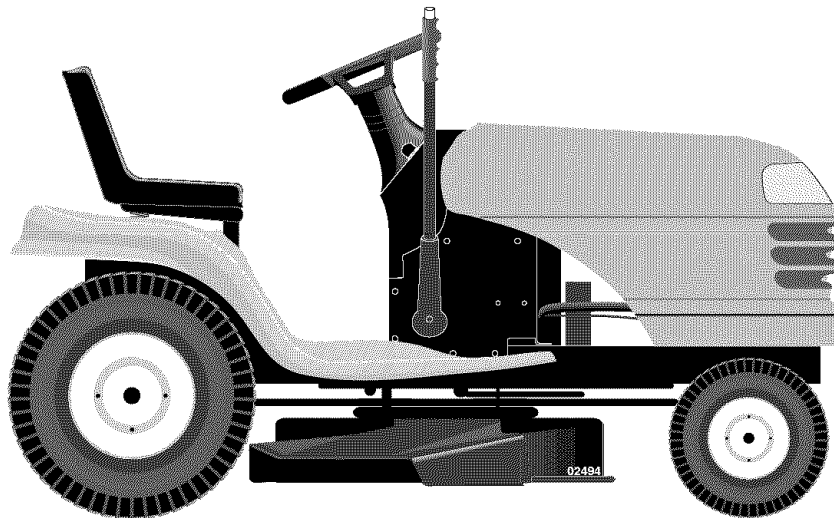

This product has a low emission engine which operates differently from previously built engines. Before you start the engine, read and understand this Owner's Manual.

IMPORTANT:

Read and follow all Safety Rules and Instructions before operating this equipment.

For answers to your questions about this product, Call:

1-800-659-5917

Sears Craftsman Help Line
5 am - 5 pm, Mon - Sat

Sears, Roebuck and Co., Hoffman Estates, IL 60179 U.S.A

Visit our Craftsman website: www.sears.com/craftsman

TABLE OF CONTENTS

Warranty	2	Maintenance Schedule	18
Safety Rules	3	Service and Adjustments.....	23
Product Specifications	6	Storage	29
AssemblyPre-Operation	8	Troubleshooting	30
Operation	11	Repair Parts.....	34
Maintenance	18	Sears Service	Back Cover

WARRANTY

LIMITED WARRANTY ON CRAFTSMAN RIDING EQUIPMENT

For two (2) years from the date of purchase, if this Craftsman Riding Equipment is maintained, lubricated and tuned up according to the instructions in the owner's manual, Sears will repair or replace free of charge any parts that are found to be defective in material or workmanship according to the guidelines of coverage listed below. Sears will also provide free labor for these applicable warranted parts for the two full years. During the first 30 days of purchase, there will be no charges to service the product at your home for issues covered by this warranty. (See exclusions below). For your convenience, IN HOME warranty service will still be available after the first 30 days of purchase, but a trip charge will apply. This charge will be waived if the Craftsman product is dropped off at an authorized Sears location. For the nearest authorized Sears location, please call 1-800-4-MY-HOME®. This warranty applies only while this product is within the United States.

This Warranty does not cover:

- Expendable items which become worn during normal use, including but not limited to blades, spark plugs, air cleaners, belts, and oil filters.
- Standard Maintenance Servicing, oil changes, or tune-ups
- Tire replacement or repair caused by punctures from outside objects, such as nails, thorns, stumps, or glass.
- Repairs necessary because of operator abuse, including but not limited to, damage caused by towing objects beyond the capability of the riding equipment, impacting objects that bend the frame or crankshaft, or over-speeding the engine.
- Repairs necessary because of operator negligence, including but not limited to, electrical and mechanical damage caused by improper storage, failure to use the proper grade and amount of engine oil, failure to keep the deck clear of flammable debris, or failure to maintain the equipment according to the instructions contained in the owner's manual.
- Engine (fuel system) cleaning or repairs caused by fuel determined to be contaminated or oxidized (stale). In general, fuel should be used within 30 days of its purchase date.
- Normal deterioration and wear of the exterior finishes, or product label replacement.
- Riding equipment used for commercial or rental purposes.

LIMITED WARRANTY ON BATTERY

For ninety (90) days from date of purchase, if any battery included with this riding equipment proves defective in material or workmanship and our testing determines the battery will not hold a charge, Sears will replace the battery at no charge. During the first 30 days of purchase, there will be no charges to replace the battery at your HOME. After the first 30 days, for your convenience, IN-HOME warranty service will still be available but a trip charge will apply. This charge will be waived if the Craftsman product is dropped off at an authorized Sears location. For the nearest authorized Sears location, please call 1-800-4-MY-HOME®.

This battery warranty applies only while this product is within the United States.

This warranty gives you specific legal rights, and you may also have other rights, which vary, from state to state.

Sears, Roebuck and Co., Dept. 817WA, Hoffman Estates, IL 60179

SAFETY RULES

IMPORTANT: This cutting machine is capable of amputating hands and feet and throwing objects. Failure to observe the following safety instructions could result in serious injury or death.

⚠️WARNING: In order to prevent accidental starting when setting up, transporting, adjusting or making repairs, always disconnect spark plug wire and place wire where it cannot contact spark plug.

⚠️WARNING: Do not coast down a hill in neutral, you may lose control of the tractor.

⚠️WARNING: Tow only the attachments that are recommended by and comply with specifications of the manufacturer of your tractor. Use common sense when towing. Operate only at the lowest possible speed when on a slope. Too heavy of a load, while on a slope, is dangerous. Tires can lose traction with the ground and cause you to lose control of your tractor.

⚠️WARNING: Engine exhaust, some of its constituents, and certain vehicle components contain or emit chemicals known to the State of California to cause cancer and birth defects or other reproductive harm.

⚠️WARNING: Battery posts, terminals and related accessories contain lead and lead compounds, chemicals known to the State of California to cause cancer and birth defects or other reproductive harm.

Wash hands after handling.

I. GENERAL OPERATION

- Read, understand, and follow all instructions on the machine and in the manual before starting.
- Do not put hands or feet near rotating parts or under the machine. Keep clear of the discharge opening at all times.
- Only allow responsible adults, who are familiar with the instructions, to operate the machine.
- Clear the area of objects such as rocks, toys, wire, etc., which could be picked up and thrown by the blades.
- Be sure the area is clear of bystanders before operating. Stop machine if anyone enters the area.
- Never carry passengers.
- Do not mow in reverse unless absolutely necessary. Always look down and behind before and while backing.
- Never direct discharged material toward anyone. Avoid discharging material against a wall or obstruction. Material may ricochet back toward the operator. Stop the blades when crossing gravel surfaces.
- Do not operate machine without the entire grass catcher, discharge guard, or other safety devices in place and working.
- Slow down before turning.
- Never leave a running machine unattended. Always turn off blades, set parking brake, stop engine, and remove keys before dismounting.
- Disengage blades when not mowing. Shut off engine and wait for all parts to come to a complete stop before cleaning the machine, removing the grass catcher, or unclogging the discharge guard.
- Operate machine only in daylight or good artificial light.
- Do not operate the machine while under the influence of alcohol or drugs.
- Watch for traffic when operating near or crossing roadways.
- Use extra care when loading or unloading the machine into a trailer or truck.
- Always wear eye protection when operating machine.
- Data indicates that operators, age 60 years and above, are involved in a large percentage of riding mower-related injuries. These operators should evaluate their ability to operate the riding mower safely enough to protect themselves and others from serious injury.
- Follow the manufacturer's recommendation for wheel weights or counterweights.
- Keep machine free of grass, leaves or other debris build-up which can touch hot exhaust / engine parts and burn. Do not allow the mower deck to plow leaves or other debris which can cause build-up to occur. Clean any oil or fuel spillage before operating or storing the machine. Allow machine to cool before storage.

SAFETY RULES

II. SLOPE OPERATION

Slopes are a major factor related to loss of control and tip-over accidents, which can result in severe injury or death. Operation on all slopes requires extra caution. If you cannot back up the slope or if you feel uneasy on it, do not mow it.

- Mow up and down slopes, not across.
- Watch for holes, ruts, bumps, rocks, or other hidden objects. Uneven terrain could overturn the machine. Tall grass can hide obstacles.
- Choose a low ground speed so that you will not have to stop or shift while on the slope.
- Do not mow on wet grass. Tires may lose traction.
Always keep the machine in gear when going down slopes. Do not shift to neutral and coast downhill.
- Avoid starting, stopping, or turning on a slope. If the tires lose traction, disengage the blades and proceed slowly straight down the slope.
- Keep all movement on the slopes slow and gradual. Do not make sudden changes in speed or direction, which could cause the machine to roll over.
- Use extra care while operating machine with grass catchers or other attachments; they can affect the stability of the machine. Do not use on steep slopes.
- Do not try to stabilize the machine by putting your foot on the ground.
- Do not mow near drop-offs, ditches, or embankments. The machine could suddenly roll over if a wheel is over the edge or if the edge caves in.

III. CHILDREN

Tragic accidents can occur if the operator is not alert to the presence of children. Children are often attracted to the machine and the mowing activity. Never assume that children will remain where you last saw them.

- Keep children out of the mowing area and in the watchful care of a responsible adult other than the operator.
- Be alert and turn machine off if a child enters the area.
- Before and while backing, look behind and down for small children.

- Never carry children, even with the blades shut off. They may fall off and be seriously injured or interfere with safe machine operation. Children who have been given rides in the past may suddenly appear in the mowing area for another ride and be run over or backed over by the machine.
- Never allow children to operate the machine.
- Use extra care when approaching blind corners, shrubs, trees, or other objects that may block your view of a child.

IV. TOWING

- Tow only with a machine that has a hitch designed for towing. Do not attach towed equipment except at the hitch point.
- Follow the manufacturer's recommendation for weight limits for towed equipment and towing on slopes.
- Never allow children or others in or on towed equipment.
- On slopes, the weight of the towed equipment may cause loss of traction and loss of control.
- Travel slowly and allow extra distance to stop.

V. SERVICE

SAFE HANDLING OF GASOLINE

To avoid personal injury or property damage, use extreme care in handling gasoline. Gasoline is extremely flammable and the vapors are explosive.

- Extinguish all cigarettes, cigars, pipes, and other sources of ignition.
- Use only approved gasoline container.
- Never remove gas cap or add fuel with the engine running. Allow engine to cool before refueling.
- Never fuel the machine indoors.
- Never store the machine or fuel container where there is an open flame, spark, or pilot light such as on a water heater or other appliances.
- Never fill containers inside a vehicle or on a truck or trailer bed with plastic liner. Always place containers on the ground away from your vehicle when filling.

SAFETY RULES

- Remove gas-powered equipment from the truck or trailer and refuel it on the ground. If this is not possible, then refuel such equipment with a portable container, rather than from a gasoline dispenser nozzle.
- Keep the nozzle in contact with the rim of the fuel tank or container opening at all times until fueling is complete. Do not use a nozzle lock-open device.
- If fuel is spilled on clothing, change clothing immediately.
- Never overfill fuel tank. Replace gas cap and tighten securely.
- Keep machine free of grass, leaves, or other debris build-up. Clean oil or fuel spillage and remove any fuel-soaked debris. Allow machine to cool before storing.
- If you strike a foreign object, stop and inspect the machine. Repair, if necessary, before restarting.
- Never make any adjustments or repairs with the engine running.
- Check grass catcher components and the discharge guard frequently and replace with manufacturer's recommended parts, when necessary.
- Mower blades are sharp. Wrap the blade or wear gloves, and use extra caution when servicing them.
- Check brake operation frequently. Adjust and service as required.
- Maintain or replace safety and instruction labels, as necessary.

GENERAL SERVICE

- Never operate machine in a closed area.
- Keep all nuts and bolts tight to be sure the equipment is in safe working condition.
- Never tamper with safety devices. Check their proper operation regularly.

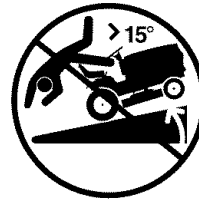

- Be sure the area is clear of bystanders before operating. Stop machine if anyone enters the area.
- Never carry passengers.
- Do not mow in reverse unless absolutely necessary. Always look down and behind before and while backing.
- Never carry children, even with the blades shut off. They may fall off and be seriously injured or interfere with safe machine operation. Children who have been given rides in the past may suddenly appear in the mowing area for another ride and be run over or backed over by the machine.
- Keep children out of the mowing area and in the watchful care of a responsible adult other than the operator.
- Be alert and turn machine off if a child enters the area.
- Before and while backing, look behind and down for small children.
- Mow up and down slopes (15° Max), not across.
- Choose a low ground speed so that you will not have to stop or shift while on the slope.
- Avoid starting, stopping, or turning on a slope. If the tires lose traction, disengage the blades and proceed slowly straight down the slope.
- If machine stops while going uphill, disengage blades, shift into reverse and back down slowly.
- Do not turn on slopes unless necessary, and then, turn slowly and gradually downhill, if possible.

PRODUCT SPECIFICATIONS

Gasoline Capacity and Type:	1.25 Gallons Unleaded Regular
Oil Type (API-SG-SL):	SAE 30 (above 32°F) SAE 5W-30 (Below 32°F)
Oil Capacity:	W/Filter: 3.5 Pints W/O Filter: 3.0 Pints
Spark Plug: (GAP: .030")	Champion RC12YC
Ground Speed (MPH):	Forward: 5.5 Reverse: 2.4
Tire Pressure:	Front: 14 PSI Rear: 10 PSI
Charging System:	3 Amps Battery 5 Amps Headlights
Battery:	Amp/Hr: 28 Min. CCA: 230 Case Size: U1R
Blade Bolt Torque:	27–35 Ft. Lbs.

CONGRATULATIONS on your purchase of a new tractor. It has been designed, engineered and manufactured to give you the best possible dependability and performance.

Should you experience any problem you cannot easily remedy, please contact a Sears or other qualified service center. We have competent, well-trained technicians and the proper tools to service or repair this tractor.

Please read and retain this manual. The instructions will enable you to assemble and maintain your tractor properly. Always observe the "SAFETY RULES".

CUSTOMER RESPONSIBILITIES

- Read and observe the safety rules.
- Follow a regular schedule in maintaining, caring for and using your tractor.
- Follow the instructions under "Maintenance" and "Storage" sections of this owner's manual.

⚠️WARNING: This tractor is equipped with an internal combustion engine and should not be used on or near any unimproved forest-covered, brush-covered or grass-covered land unless the engine's exhaust system is equipped with a spark arrester meeting applicable local or state laws (if any). If a spark arrester is used, it should be maintained in effective working order by the operator.

In the state of California the above is required by law (Section 4442 of the California Public Resources Code). Other states may have similar laws. Federal laws apply on federal lands. A spark arrester for the muffler is available through your nearest Sears service center (See REPAIR PARTS section of this manual).

REPAIR PROTECTION AGREEMENTS

Congratulations on making a smart purchase. Your new Craftsman® product is designed and manufactured for years of dependable operation. But like all products, it may require repair from time to time. That's when having a Repair Protection Agreement can save you money and aggravation.

Purchase a Repair Protection Agreement now and protect yourself from unexpected hassle and expense.

Here's what's included in the Agreement:

- **Expert service** by our 12,000 professional repair specialists.
- **Unlimited service and no charge** for parts and labor on all covered repairs.
- **Product replacement** if your covered product can't be fixed.
- **Discount of 10%** from regular price of service and service-related parts not covered by the agreement; also, 10% off regular price of preventive maintenance check.
- **Fast help by phone** – phone support from a Sears technician on products requiring in-home repair, plus convenient repair scheduling.

Once you purchase the Agreement, a simple phone call is all that it takes for you to schedule service. You can call anytime day or night, or schedule a service appointment online.

Sears has over 12,000 professional repair specialists, who have access to over 4.5 million quality parts and accessories. That's the kind of professionalism you can count on to help prolong the life of your new purchase for years to come. Purchase your Repair Protection Agreement today! **Some limitations and exclusions apply. For prices and additional information call 1-800-827-6655.**

SEARS INSTALLATION SERVICE

For Sears professional installation of home appliances, garage door openers, water heaters, and other major home items, in the U.S.A. call 1-800-4-MY-HOME®

UNASSEMBLED PARTS

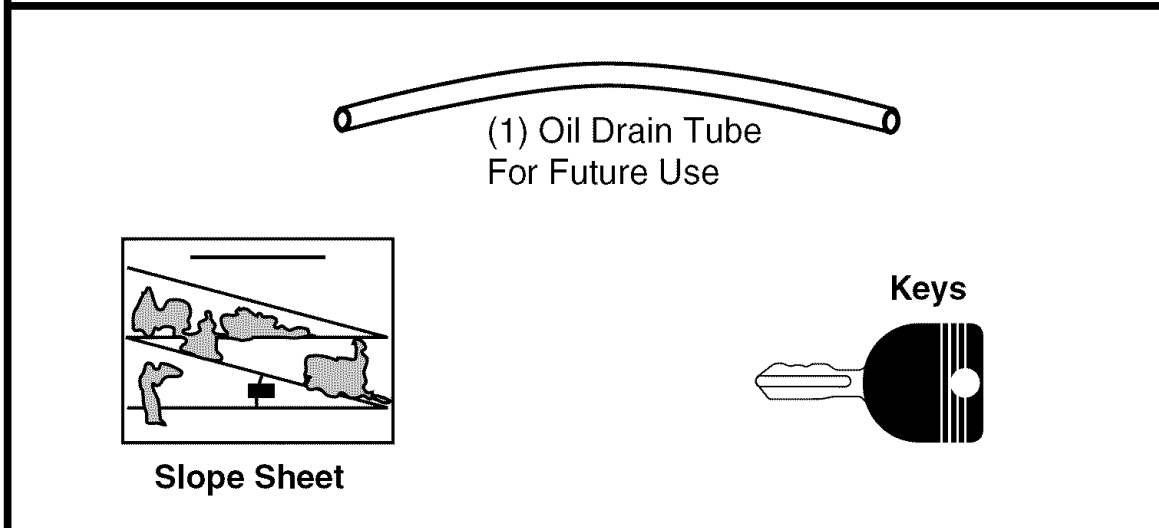
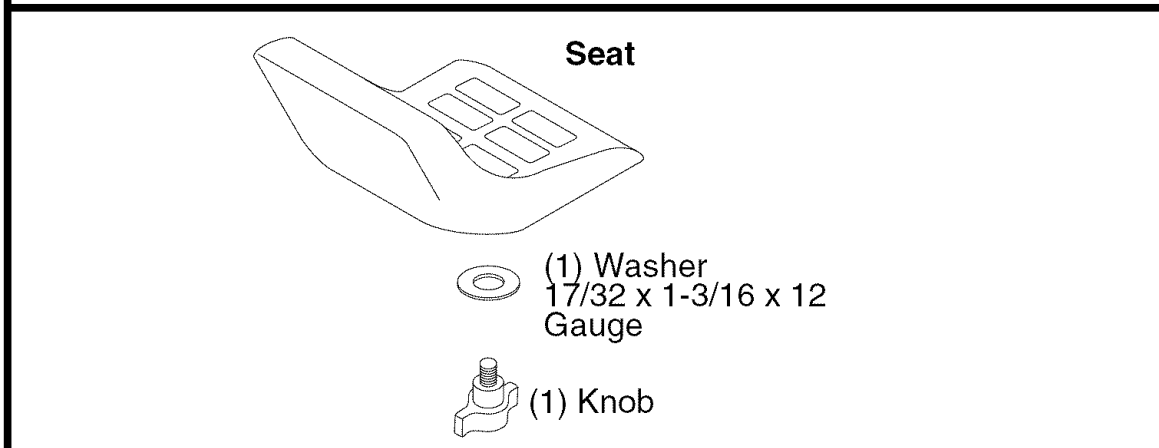
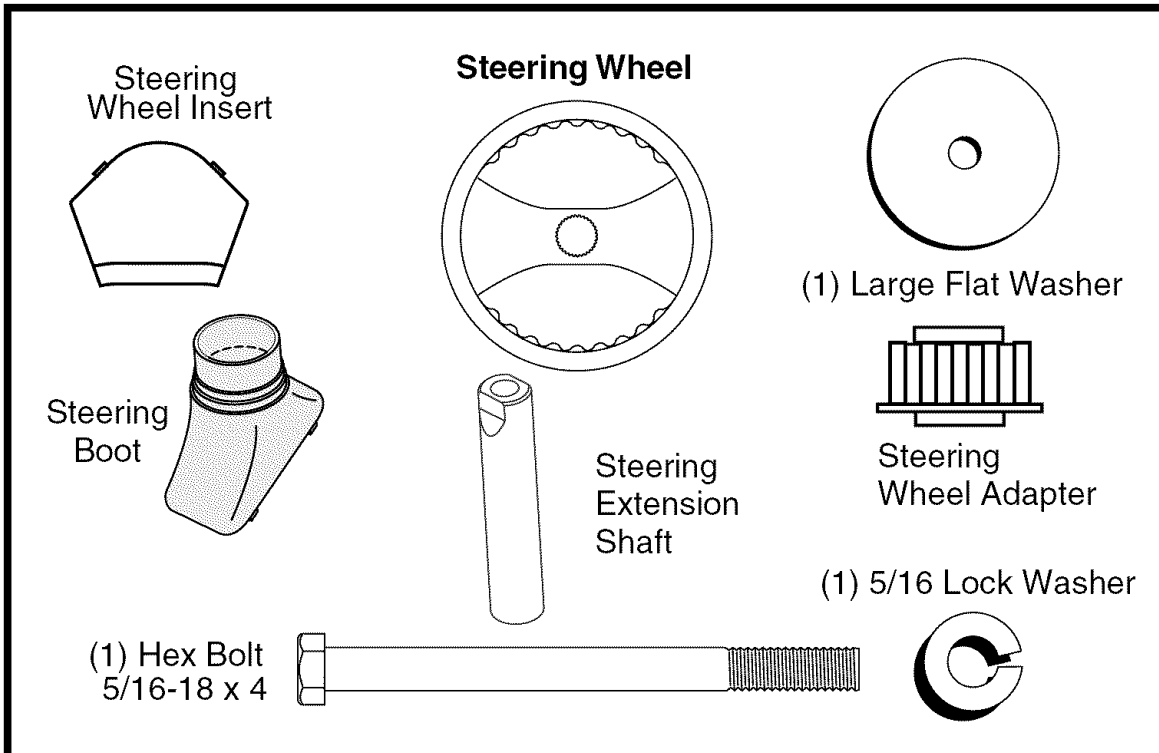

ASSEMBLY/PRE-OPERATION

Your new tractor has been assembled at the factory with the exception of those parts left unassembled for shipping purposes. To ensure safe and proper operation of your tractor all parts and hardware you assemble must be tightened securely. Use the correct tools as necessary to insure proper tightness.

TOOLS REQUIRED FOR ASSEMBLY

A socket wrench set will make assembly easier. Standard wrench sizes you need are listed below.

- (1) 3/4" wrench
- (1) Pliers
- (1) 1/2" wrench
- (1) Utility knife
- (1) Tire pressure gauge

When right or left hand is mentioned in this manual, it means, from your point of view, when you are in the operating position (seated behind the steering wheel).

TO REMOVE TRACTOR FROM CARTON

UNPACK CARTON

1. Remove all accessible loose parts and parts boxes from carton.
2. Cut along dotted lines on all four panels of carton. Remove end panels and lay side panels flat.
3. Check for any additional loose parts or cartons and remove.

BEFORE REMOVING TRACTOR FROM SKID

ATTACH STEERING WHEEL

ASSEMBLE EXTENSION SHAFT AND BOOT

1. Slide extension shaft onto lower steering shaft.
2. Place tabs of steering boot over tab slots in dash and push down to secure.

INSTALL STEERING WHEEL

3. Position front wheels of the tractor so they are pointing straight forward.
4. Remove steering wheel adapter from steering wheel and slide adapter onto steering shaft extension.
5. Position steering wheel so cross bars are horizontal (left to right) and slide inside boot and onto adapter.
6. Assemble large flat washer, 5/16 lock washer, 5/16 hex bolt and tighten securely.
7. Snap steering wheel insert into center of steering wheel.
8. Remove protective materials from tractor hood and grill.

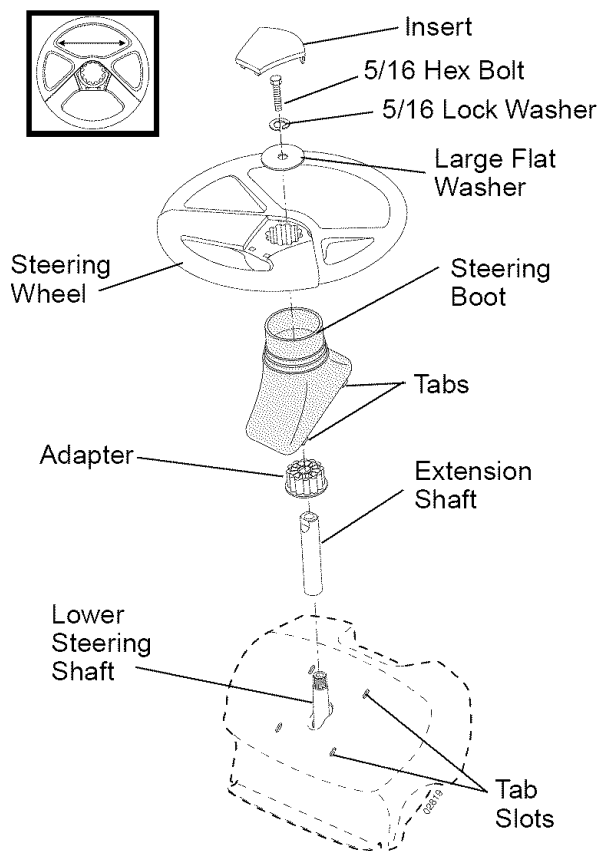

IMPORTANT: Check for and remove any staples in skid that may puncture tires where tractor is to roll off skid.

INSTALL SEAT

1. Remove adjustment bolt, lock washer and flat washer securing seat to cardboard packing and set aside for assembly of seat to tractor.
2. Pivot seat upward and remove from the cardboard packing. Remove the cardboard packing and discard.
3. Place seat on seat pan so head of shoulder bolts are positioned over the large slotted holes in pan.
4. Push down on seat to engage shoulder bolts in slots and pull seat towards rear of tractor.
5. Pivot seat and pan forward and assemble adjustment bolt, lockwasher and flat washer loosely. Do not tighten.
6. Lower seat into operating position and sit in seat.

7. Slide seat until a comfortable position is reached which allows you to press clutch/brake pedal all the way down.
8. Get off seat without moving its adjusted position.
9. Raise seat and tighten adjustment bolt securely.

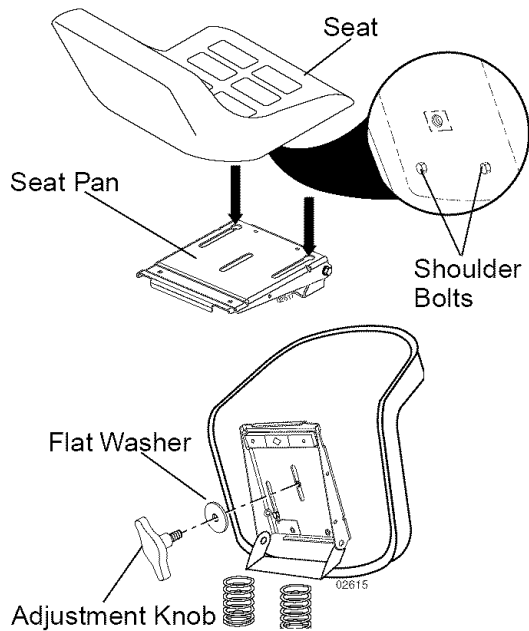

CHECK BATTERY

1. Lift seat pan to raised position.
- NOTE:** If this battery is put into service after month and year indicated on label (label located between terminals) charge battery for minimum of one hour at 6-10 amps. (See "BATTERY" in Maintenance section of this manual for charging instructions).

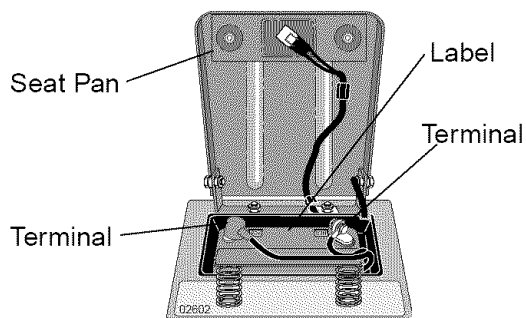

NOTE: You may now roll or drive your tractor off the skid. Follow the appropriate instruction below to remove the tractor from the skid.

TO ROLL TRACTOR OFF SKID (See Operation section for location and function of controls)

1. Press lift lever plunger and raise attachment lift lever to its highest position.
2. Release parking brake by depressing clutch/brake pedal.
3. Place freewheel control in "transmission disengaged" position (See "TO TRANSPORT" in the Operation section of this manual).
4. Roll tractor forward off skid.
5. Remove banding holding deflector shield up against tractor.

TO DRIVE TRACTOR OFF SKID (See Operation section for location and function of controls)

⚠ WARNING: Before starting, read, understand and follow all instructions in the Operation section of this manual. Be sure tractor is in a well-ventilated area. Be sure the area in front of tractor is clear of other people and objects.

1. Be sure all the above assembly steps have been completed.
2. Check engine oil level and fill fuel tank with gasoline.
3. Place freewheel control in "transmission engaged" position. (See "TO TRANSPORT" in the Operation section of this manual).
4. Sit on seat in operating position, depress clutch/brake pedal and set the parking brake.
5. Place motion control lever in neutral (N) position.
6. Press lift lever plunger and raise attachment lift lever to its highest position.
7. Start the engine. After engine has started, move throttle control to idle position.
8. Release parking brake.
9. Slowly move the motion control lever forward and slowly drive tractor off skid.
10. Apply brake to stop tractor, set parking brake and place motion control lever in neutral position.
11. Turn ignition key to "STOP" position. Continue with the instructions that follow.

CHECK TIRE PRESSURE

The tires on your tractor were overinflated at the factory for shipping purposes. Correct tire pressure is important for best cutting performance.

- Reduce tire pressure to PSI shown in “PRODUCT SPECIFICATIONS” section of this manual.

CHECK DECK LEVELNESS

For best cutting results, mower housing should be properly leveled. See “TO LEVEL MOWER HOUSING” in the Service and Adjustments section of this manual.

CHECK FOR PROPER POSITION OF ALL BELTS

See the figures that are shown for replacing motion and mower blade drive belts in the Service and Adjustments section of this manual. Verify that the belts are routed correctly.

CHECK BRAKE SYSTEM

After you learn how to operate your tractor, check to see that the brake is properly adjusted. See “TO ADJUST BRAKE” in the Service and Adjustments section of this manual.

✓CHECKLIST

Before you operate your new tractor, we wish to assure that you receive the best performance and satisfaction from this quality product.

Please review the following checklist:

- ✓ All assembly instructions have been completed.
- ✓ No remaining loose parts in carton.
- ✓ Battery is properly prepared and charged. (Minimum 1 hour at 6 amps).
- ✓ Seat is adjusted comfortably and tightened securely.
- ✓ All tires are properly inflated. (For shipping purposes, the tires were overinflated at the factory).
- ✓ Be sure mower deck is properly leveled side-to-side/front-to-rear for best cutting results. (Tires must be properly inflated for leveling).
- ✓ Check mower and drive belts. Be sure they are routed properly around pulleys and inside all belt keepers.
- ✓ Check wiring. See that all connections are still secure and wires are properly clamped.
- ✓ Before driving tractor, be sure freewheel control is in “transmission engaged” position (see “TO TRANSPORT” in the Operation section of this manual).

While learning how to use your tractor, pay extra attention to the following important items:

- ✓ Engine oil is at proper level.
- ✓ Fuel tank is filled with fresh, clean, regular unleaded gasoline.
- ✓ Become familiar with all controls - their location and function. Operate them before you start the engine.
- ✓ Be sure brake system is in safe operating condition.
- ✓ Be sure Operator Presence System and Reverse Operation System (ROS) are working properly (See the Operation and Maintenance sections in this manual).
- ✓ It is important to purge the transmission before operating your tractor for the first time. Follow proper starting and transmission purging instructions (See “TO START ENGINE” and “PURGE TRANSMISSION” in the Operation section of this manual).

OPERATION

These symbols may appear on your tractor or in literature supplied with the product. Learn and understand their meaning.

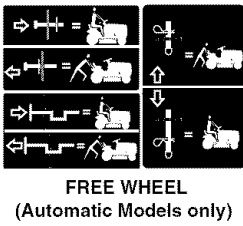
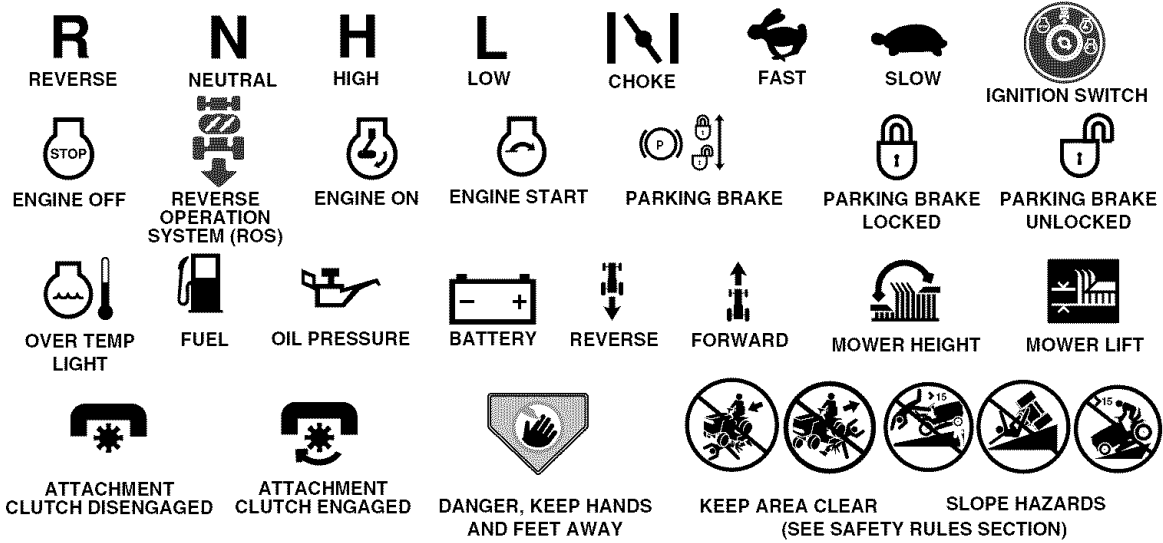

Failure to follow instructions could result in serious injury or death. The safety alert symbol is used to identify safety information about hazards which can result in death, serious injury and/or property damage.

-  **DANGER** indicates a hazard which, if not avoided, will result in death or serious injury.
-  **WARNING** indicates a hazard which, if not avoided, could result in death or serious injury.
-  **CAUTION** indicates a hazard which, if not avoided, might result in minor or moderate injury.
- CAUTION** when used **without** the alert symbol, indicates a situation that **could result in damage to the tractor and/or engine.**
-  **HOT SURFACES** indicates a hazard which, if not avoided, **could result in death, serious injury and/or property damage.**
-  **FIRE** indicates a hazard which, if not avoided, **could result in death, serious injury and/or property damage.**

KNOW YOUR TRACTOR

READ THIS OWNER'S MANUAL AND SAFETY RULES BEFORE OPERATING YOUR TRACTOR

Compare the illustrations with your tractor to familiarize yourself with the locations of various controls and adjustments. Save this manual for future reference.

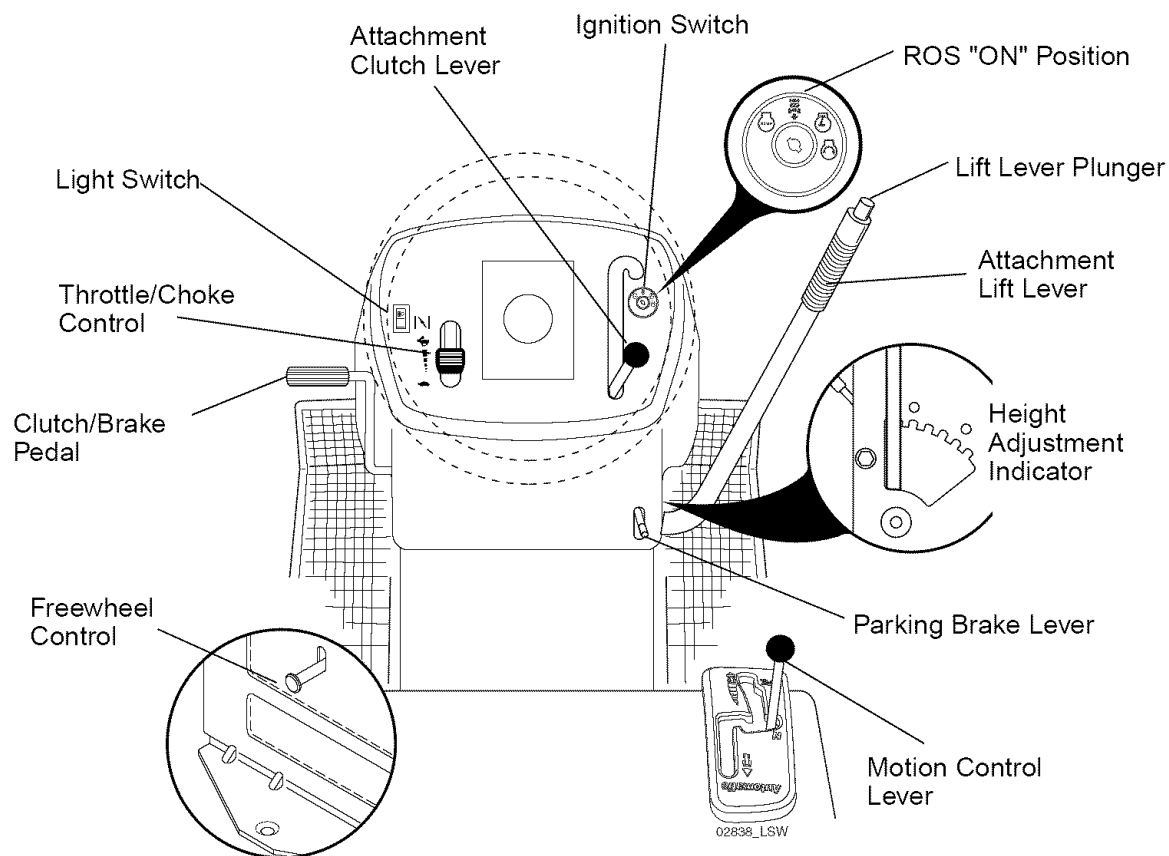

Our tractors conform to the safety standards of the American National Standards Institute.

ATTACHMENT CLUTCH LEVER - Used to engage the mower blades, or other attachments mounted to your tractor.

ATTACHMENT LIFT LEVER - Used to raise, lower, and adjust the mower deck or other attachments mounted to your tractor.

CLUTCH/BRAKE PEDAL - Used for declutching and braking the tractor and starting the engine.

FREEWHEEL CONTROL - Disengages transmission for pushing or slowly towing the tractor with the engine off.

IGNITION SWITCH - Used for starting and stopping the engine.

LIFT LEVER PLUNGER - Used to release attachment lift lever when changing its position.

LIGHT SWITCH - Turns the headlights on and off.

MOTION CONTROL LEVER - Selects the speed and direction of tractor.

PARKING BRAKE LEVER - Locks clutch/brake pedal into the brake position.

REVERSE OPERATION SYSTEM (ROS) "ON" POSITION - Allows operation of mower deck or other powered attachment while in reverse.

THROTTLE/CHOKE CONTROL - Used for starting and controlling engine speed.



The operation of any tractor can result in foreign objects thrown into the eyes, which can result in severe eye damage. Always wear safety glasses or eye shields while operating your tractor or performing any adjustments or repairs. We recommend standard safety glasses or a wide vision safety mask worn over spectacles.

HOW TO USE YOUR TRACTOR TO SET PARKING BRAKE

Your tractor is equipped with an operator presence sensing switch. When engine is running, any attempt by the operator to leave the seat without first setting the parking brake will shut off the engine.

1. Depress clutch/brake pedal all the way down and hold.
2. Pull parking brake lever up and release pressure from clutch/brake pedal. Pedal should remain in brake position. Make sure parking brake will hold tractor secure.

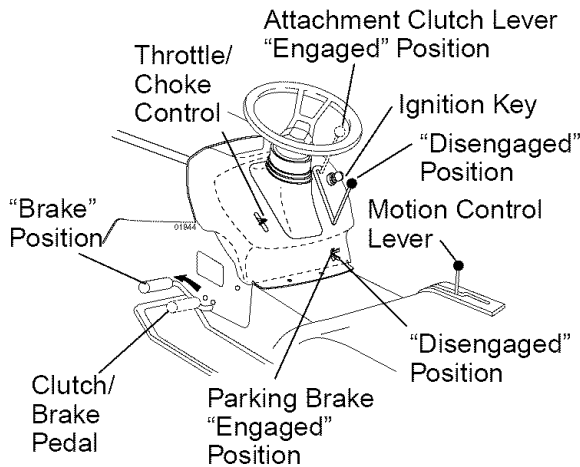

STOPPING

MOWER BLADES -

- To stop mower blades, move attachment clutch lever to "DISENGAGED" position.

GROUND DRIVE -

- To stop ground drive, depress clutch/brake pedal all the way down.
- Move motion control lever to neutral (N) position.

IMPORTANT: The motion control lever does not return to neutral (N) position when the clutch/brake pedal is depressed.

ENGINE -

- Move throttle control between half and full speed (fast) position.
- NOTE:** Failure to move throttle control between half and full speed (fast) position, before stopping, may cause engine to "backfire".
- Turn ignition key to "STOP" position and remove key. Always remove key when leaving tractor to prevent unauthorized use.

- Never use choke to stop engine.

IMPORTANT: Leaving the ignition switch in any position other than "STOP" will cause the battery to discharge and go dead.

NOTE: Under certain conditions when tractor is standing idle with the engine running, hot engine exhaust gases may cause "browning" of grass. To eliminate this possibility, always stop engine when stopping tractor on grass areas.

CAUTION: Always stop tractor completely, as described above, before leaving the operator's position.

TO USE THROTTLE CONTROL

Always operate engine at full throttle.

- Operating engine at less than full throttle reduces the battery charging rate.
- Full throttle offers the best bagging and mower performance.

TO MOVE FORWARD AND BACKWARD

The direction and speed of movement is controlled by the motion control lever.

1. Start tractor with motion control lever in neutral (N) position.
2. Release parking brake.
3. Slowly move motion control lever to desired position.

TO ADJUST MOWER CUTTING HEIGHT

The position of the attachment lift lever determines the cutting height.

- Grasp lift lever.
- Press plunger with thumb and move lever to desired position.

The cutting height range is approximately 1-1/2 to 4". The heights are measured from the ground to the blade tip with the engine not running. These heights are approximate and may vary depending upon soil conditions, height of grass and types of grass being mowed.

- The average lawn should be cut to approximately 2-1/2 inches during the cool season and to over 3 inches during hot months. For healthier and better looking lawns, mow often and after moderate growth.
- For best cutting performance, grass over 6 inches in height should be mowed twice. Make the first cut relatively high; the second to desired height.

TO ADJUST GAUGE WHEELS

Gauge wheels are properly adjusted when they are slightly off the ground when mower is at the desired cutting height in operating position. Gauge wheels then keep the deck in proper position to help prevent scalping in most terrain conditions. **NOTE:** Adjust gauge wheels with tractor on a flat level surface.

1. Adjust mower to desired cutting height (See "TO ADJUST MOWER CUTTING HEIGHT" in this section of manual).
2. With mower in desired height of cut position, gauge wheels should be assembled so they are slightly off the ground. Install gauge wheel in appropriate hole with shoulder bolt, 3/8 washer, and 3/8-16 locknut and tighten securely.
3. Repeat for opposite side, installing gauge wheel in same adjustment hole.

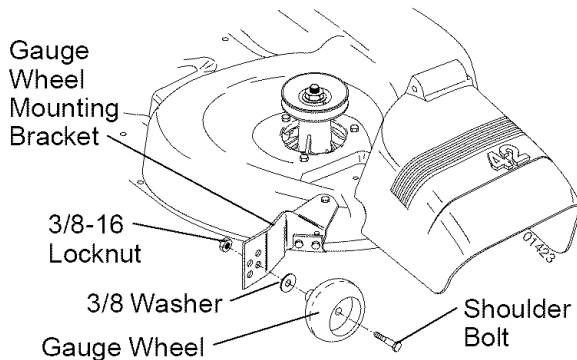

TO OPERATE MOWER

Your tractor is equipped with an operator presence sensing switch. Any attempt by the operator to leave the seat with the engine running and the attachment clutch engaged will shut off the engine. You must remain fully and centrally positioned in the seat to prevent the engine from hesitating or cutting off when operating your equipment on rough, rolling terrain or hills.

1. Select desired height of cut.
2. Start mower blades by engaging attachment clutch control.

TO STOP MOWER BLADES - disengage attachment clutch control.

CAUTION: Do not operate the mower without either the entire grass catcher, on mowers so equipped, or the deflector shield in place.

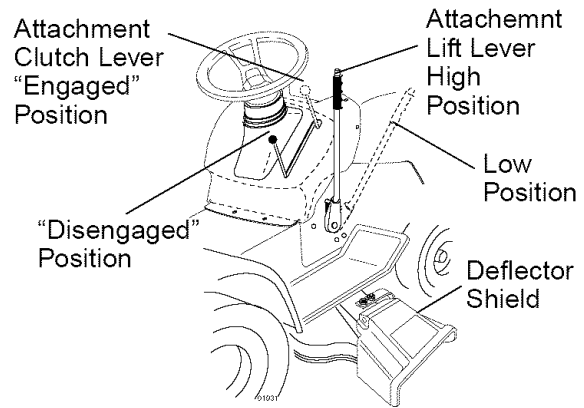

OPERATING IN REVERSE

Your tractor is equipped with a Reverse Operation System (ROS). Any attempt by the operator to travel in the reverse direction with the attachment clutch engaged will shut off the engine unless the ignition key is placed in the ROS "ON" position.

WARNING: Backing up with the attachment clutch engaged while mowing is strongly discouraged. Turning the ROS "ON", to allow reverse operation with the attachment clutch engaged, should only be done when the operator decides it is necessary to reposition the machine with the attachment engaged. **Do not mow in reverse unless absolutely necessary.**

USING THE REVERSE OPERATION SYSTEM -

1. Move motion control lever to neutral (N) position.
2. With engine running, turn ignition key counterclockwise to ROS "ON" position.
3. Look down and behind before backing up.
4. Slowly move motion control lever to reverse (R) position to start movement.
5. When use of the ROS is no longer needed, turn the ignition key clockwise to engine "ON" position.

ROS "ON" Position

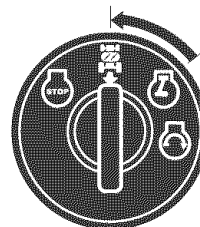

Engine "ON" Position (Normal Operating)

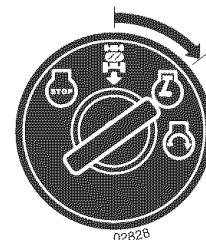

TO OPERATE ON HILLS

⚠ WARNING: Do not drive up or down hills with slopes greater than 15° and do not drive across any slope. Use the slope guide at the back of this manual.

- Choose the slowest speed before starting up or down hills.
- Avoid stopping or changing speed on hills.
- If slowing is necessary, move throttle control lever to slower position.
- If stopping is absolutely necessary, push clutch/brake pedal quickly to brake position and engage parking brake.
- Move motion control lever to neutral (N) position.

IMPORTANT: The motion control lever does not return to neutral (N) position when the clutch/brake pedal is depressed.

- To restart movement, slowly release parking brake and clutch/brake pedal.
- Slowly move motion control lever to slowest setting.
- Make all turns slowly.

TO TRANSPORT

When pushing or towing your tractor, be sure to disengage transmission by placing freewheel control in freewheeling position. Freewheel control is located at the rear drawbar of tractor.

1. Raise attachment lift to highest position with attachment lift control.
 2. Pull freewheel control out and down into the slot and release so it is held in the disengaged position.
- Do not push or tow tractor at more than two (2) MPH.
 - To re-engage transmission, reverse above procedure.

Transmission Engaged

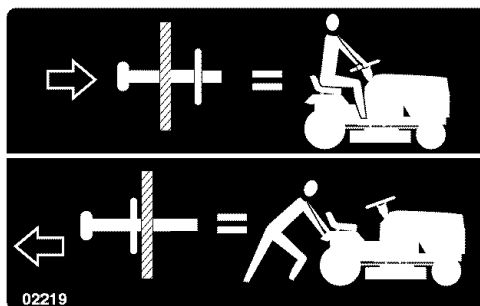

Transmission Disengaged

NOTE: To protect hood from damage when transporting your tractor on a truck or a trailer, be sure hood is closed and secured to tractor. Use an appropriate means of tying hood to tractor (rope, cord, etc.).

TOWING CARTS AND OTHER ATTACHMENTS

Tow only the attachments that are recommended by and comply with specifications of the manufacturer of your tractor. Use common sense when towing. Too heavy of a load, while on a slope, is dangerous. Tires can lose traction with the ground and cause you to lose control of your tractor.

BEFORE STARTING THE ENGINE CHECK ENGINE OIL LEVEL

The engine in your tractor has been shipped, from the factory, already filled with summer weight oil.

1. Check engine oil with tractor on level ground.
 2. Remove oil fill cap/dipstick and wipe clean, reinsert the dipstick and screw cap tight, wait for a few seconds, remove and read oil level. If necessary, add oil until "FULL" mark on dipstick is reached. Do not overfill.
- For cold weather operation you should change oil for easier starting ((See the oil viscosity chart in the Maintenance section of this manual)).
 - To change engine oil, see the Maintenance section in this manual.

ADD GASOLINE

- Fill fuel tank to bottom of tank filler neck. Do not overfill. Use fresh, clean, regular unleaded gasoline with a minimum of 87 octane. (Use of leaded gasoline will increase carbon and lead oxide deposits and reduce valve life). Do not mix oil with gasoline. Purchase fuel in quantities that can be used within 30 days to assure fuel freshness.

⚠ CAUTION: Wipe off any spilled oil or fuel. Do not store, spill or use gasoline near an open flame.

IMPORTANT: When operating in temperatures below 32°F(0°C), use fresh, clean winter grade gasoline to help insure good cold weather starting.

CAUTION: Alcohol blended fuels (called gasohol or using ethanol or methanol) can attract moisture which leads to separation and formation of acids during storage. Acidic gas can damage the fuel system of an engine while in storage.

To avoid engine problems, the fuel system should be emptied before storage of 30 days or longer. Drain the gas tank, start the engine and let it run until the fuel lines and carburetor are empty. Use fresh fuel next season. See Storage Instructions for additional information.

Never use engine or carburetor cleaner products in the fuel tank or permanent damage may occur.

TO START ENGINE

When starting the engine for the first time or if the engine has run out of fuel, it will take extra cranking time to move fuel from the tank to the engine.

1. Be sure freewheel control is in the transmission engaged position.
2. Sit on seat in operating position, depress clutch/brake pedal and set parking brake.
3. Place motion control lever in neutral (N) position.
4. Move attachment clutch to disengaged position.
5. Move throttle control to choke position.

NOTE: Before starting, read the warm and cold starting procedures below.

6. Insert key into ignition and turn key clockwise to start position and release key as soon as engine starts. Do not run starter continuously for more than fifteen seconds per minute. If the engine does not start after several attempts, move throttle control to fast position, wait a few minutes and try again. If engine still does not start, move the throttle control back to the choke position and retry.

WARM WEATHER STARTING (50° F and above)

7. When engine starts, move the throttle control to the fast position.
 - The attachments and ground drive can now be used. If the engine does not accept the load, restart the engine and allow it to warm up for one minute using the choke as described above.

COLD WEATHER STARTING (50° F and below)

7. When engine starts, allow engine to run with the throttle control in the choke position until the engine runs roughly, then move throttle control to fast position. This may require an engine warm-up period from several seconds to several minutes, depending on the temperature.

AUTOMATIC TRANSMISSION WARM UP

Before driving the unit in cold weather, the transmission should be warmed up as follows:

1. Be sure the tractor is on level ground.
2. Place the motion control lever in neutral. Release the parking brake and let the clutch/brake slowly return to operating position.
3. Allow one minute for transmission to warm up. This can be done during the engine warm up period.
 - The attachments can also be used during the engine warm-up period after the transmission has been warmed up.

NOTE: If at a high altitude (above 3000 feet) or in cold temperatures (below 32 F) the carburetor fuel mixture may need to be adjusted for best engine performance. (See "TO ADJUST CARBURETOR" in the Service and Adjustments section of this manual.)

PURGE TRANSMISSION

To ensure proper operation and performance, it is recommended that the transmission be purged before operating tractor for the first time. This procedure will remove any trapped air inside the transmission which may have developed during shipping of your tractor.

IMPORTANT: Should your transmission require removal for service or replacement, it should be purged after reinstallation before operating the tractor.

1. Place tractor safely in an area that is flat for approximately 80 feet in front of the tractor and set the parking brake.
2. Sitting in the tractor seat, start engine. After the engine is running, move throttle control to slow position. With motion control lever in neutral (N) position, slowly disengage clutch/brake pedal.
3. Slowly move motion control lever to full forward position and hold for five (5) seconds, or approximately 40 feet. Slowly move lever to full reverse position and hold for five (5) seconds, or approximately 20 feet. After the tractor moves approximately 20 feet in reverse return the motion control lever to the neutral (N) position. Repeat this procedure three (3) times.

Your transmission is now purged and now ready for normal operation.

MOWING TIPS

- Mower should be properly leveled for best mowing performance. See "TO LEVEL MOWER HOUSING" in the Service and Adjustments section of this manual.
- The left hand side of mower should be used for trimming.
- Drive so that clippings are discharged onto the area that has already been cut. Have the cut area to the right of the tractor. This will result in a more even distribution of clippings and more uniform cutting.
- When mowing large areas, start by turning to the right so that clippings will discharge away from shrubs, fences, driveways, etc. After one or two rounds, mow in the opposite direction making left hand turns until finished.

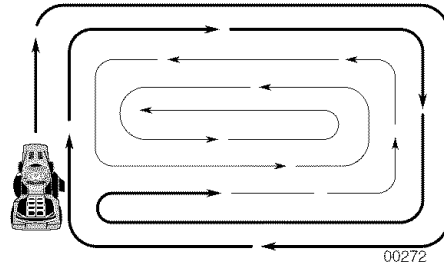

- If grass is extremely tall, it should be mowed twice to reduce load and possible fire hazard from dried clippings. Make first cut relatively high; the second to the desired height.
- Do not mow grass when it is wet. Wet grass will plug mower and leave undesirable clumps. Allow grass to dry before mowing.
- **Always operate engine at full throttle when mowing** to assure better mowing performance and proper discharge of material. Regulate ground speed by selecting a low enough gear to give the mower cutting performance as well as the quality of cut desired.
- When operating attachments, select a ground speed that will suit the terrain and give best performance of the attachment being used.

MAINTENANCE

MAINTENANCE SCHEDULE FILL IN DATES AS YOU COMPLETE REGULAR SERVICE		BEFORE EACH USE	EVERY 8 HOURS	EVERY 25 HOURS	EVERY 50 HOURS	EVERY 100 HOURS	EVERY SEASON	BEFORE STORAGE	SERVICE DATES			
T R A C T O R	Check Brake Operation	✓	✓									
	Check Tire Pressure	✓	✓									
	Check Operator Presence and ROS Systems	✓										
	Check for Loose Fasteners	✓				✓ ₅		✓				
	Sharpen/Replace Mower Blades				✓ ₃							
	Lubrication Chart				✓			✓				
	Check Battery Level				✓ ₄							
	Clean Battery and Terminals				✓			✓				
	Check Transaxle Cooling				✓							
	Check V-Belts					✓						
E N G I N E	Check Engine Oil Level	✓	✓									
	Change Engine Oil (with oil filter)				✓ _{1,2}		✓					
	Change Engine Oil (without oil filter)				✓ _{1,2}			✓				
	Clean Air Filter				✓ ₂							
	Clean Air Screen				✓ ₂							
	Inspect Muffler/Spark Arrester				✓							
	Replace Oil Filter (If equipped)						✓ _{1,2}					
	Clean Engine Cooling Fins						✓ ₂					
	Replace Spark Plug						✓	✓				
	Replace Air Filter Paper Cartridge						✓ ₂					
	Replace Fuel Filter							✓				

1 - Change more often when operating under a heavy load or in high ambient temperatures.
2 - Service more often when operating in dirty or dusty conditions.

3 - Replace blades more often when mowing in sandy soil.
4 - Not required if equipped with maintenance-free battery.
5 - Tighten front axle pivot bolt to 35 ft.-lbs. maximum. Do not overtighten.

GENERAL RECOMMENDATIONS

The warranty on this tractor does not cover items that have been subjected to operator abuse or negligence. To receive full value from the warranty, operator must maintain tractor as instructed in this manual.

Some adjustments will need to be made periodically to properly maintain your tractor.

At least once a season, check to see if you should make any of the adjustments described in the Service and Adjustments section of this manual.

- At least once a year you should replace the spark plug, clean or replace air filter, and check blades and belts for wear. A new spark plug and clean air filter assure proper air-fuel mixture and help your engine run better and last longer.

BEFORE EACH USE

- Check engine oil level.
- Check brake operation.
- Check tire pressure.
- Check operator presence and ROS systems for proper operation.
- Check for loose fasteners.

LUBRICATION CHART

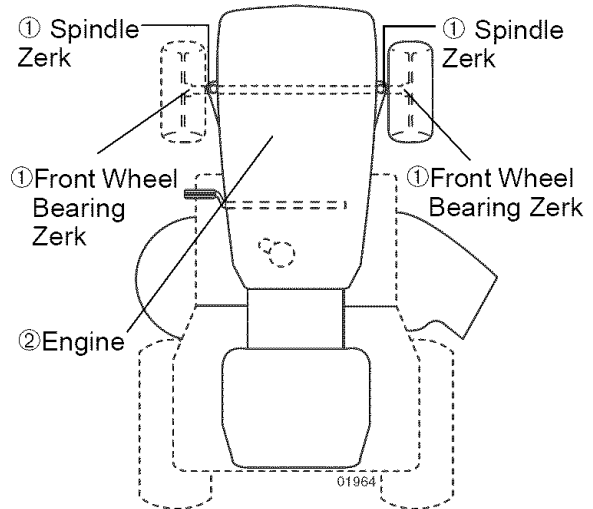

- General Purpose Grease
- REFER TO Maintenance "ENGINE" SECTION

IMPORTANT: Do not oil or grease the pivot points which have special nylon bearings. Viscous lubricants will attract dust and dirt that will shorten the life of the self-lubricating bearings. If you feel they must be lubricated, use only a dry, powdered graphite type lubricant sparingly.

TRACTOR

Always observe safety rules when performing any maintenance.

BRAKE OPERATION

If tractor requires more than five (5) feet to stop at highest speed in highest gear on a level, dry concrete or paved surface, then brake must be checked and adjusted. (See "TO ADJUST BRAKE" in the Service and Adjustments section of this manual).

TIRES

- Maintain proper air pressure in all tires (See "PRODUCT SPECIFICATIONS" section of this manual).
- Keep tires free of gasoline, oil, or insect control chemicals which can harm rubber.
- Avoid stumps, stones, deep ruts, sharp objects and other hazards that may cause tire damage.

NOTE: To seal tire punctures and prevent flat tires due to slow leaks, tire sealant may be purchased from your local parts dealer. Tire sealant also prevents tire dry rot and corrosion.

OPERATOR PRESENCE SYSTEM AND REVERSE OPERATION SYSTEM (ROS)

Be sure operator presence and reverse operation systems are working properly. If your tractor does not function as described, repair the problem immediately.

- The engine should not start unless the brake pedal is fully depressed, and the attachment clutch control is in the disengaged position.

CHECK OPERATOR PRESENCE SYSTEM

- When the engine is running, any attempt by the operator to leave the seat without first setting the parking brake should shut off the engine.
- When the engine is running and the attachment clutch is engaged, any attempt by the operator to leave the seat should shut off the engine.
- The attachment clutch should never operate unless the operator is in the seat.

CHECK REVERSE OPERATION (ROS) SYSTEM

- When the engine is running with the ignition switch in the engine "ON" position and the attachment clutch is engaged, any attempt by the operator to shift into reverse should shut off the engine.

ROS "ON" Position

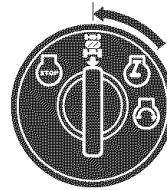

Engine "ON" Position (Normal Operating)

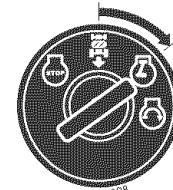

- When the engine is running with the ignition switch in the ROS "ON" position and the attachment clutch is engaged, any attempt by the operator to shift into reverse should NOT shut off the engine

BLADE CARE

For best results mower blades must be kept sharp. Replace bent or damaged blades.

BLADE REMOVAL

1. Raise mower to highest position to allow access to blades.
2. Remove blade bolt, lock washer and flat washer securing blade.
3. Install new or resharpened blade with trailing edge up towards deck as shown.

IMPORTANT: To ensure proper assembly, center hole in blade must align with star on mandrel assembly.

4. Reassemble blade bolt, lock washer and flat washer in exact order as shown.
5. Tighten blade bolt securely (27-35 Ft. Lbs. torque).

IMPORTANT: Blade bolt is heat treated.

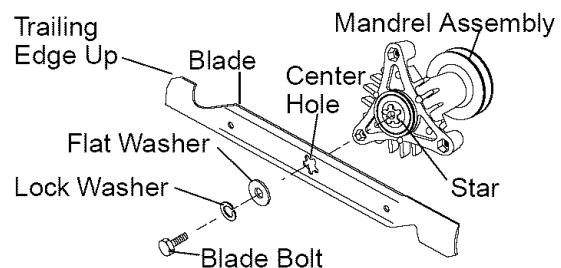

If bolt needs replacing, replace only with approve bolt shown in the Repair Parts.

TO SHARPEN BLADE

NOTE: We do not recommend sharpening blade - but if you do, be sure the blade is balanced.

Care should be taken to keep the blade balanced. An unbalanced blade will cause excessive vibration and eventual damage to mower and engine.

- The blade can be sharpened with a file or on a grinding wheel. Do not attempt to sharpen while on the mower.
- To check blade balance, you will need a 5/8" diameter steel bolt, pin, or a cone balancer. (When using a cone balancer, follow the instructions supplied with balancer.)

NOTE: Do not use a nail for balancing blade. The lobes of the center hole may appear to be centered, but are not.

- Slide blade on to an unthreaded portion of the steel bolt or pin and hold the bolt or pin parallel with the ground. If blade is balanced, it should remain in a horizontal position. If either end of the blade moves downward, sharpen the heavy end until the blade is balanced.

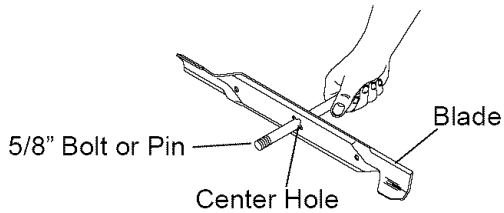

BATTERY

Your tractor has a battery charging system which is sufficient for normal use. However, periodic charging of the battery with an automotive charger will extend its life.

- Keep battery and terminals clean.
- Keep battery bolts tight.
- Keep small vent holes open.
- Recharge at 6-10 amperes for 1 hour.

NOTE: The original equipment battery on your tractor is maintenance free. Do not attempt to open or remove caps or covers. Adding or checking level of electrolyte is not necessary.

TO CLEAN BATTERY AND TERMINALS
Corrosion and dirt on the battery and terminals can cause the battery to "leak" power.

1. Disconnect **BLACK** battery cable first then **RED** battery cable and remove battery from tractor.
2. Rinse the battery with plain water and dry.
3. Clean terminals and battery cable ends with wire brush until bright.
4. Coat terminals with grease or petroleum jelly.
5. Reinstall battery (See "REPLACING BATTERY" in the Service and Adjustments section of this manual).

TRANSAXLE COOLING

The transmission fan and cooling fins should be kept clean to assure proper cooling.

Do not attempt to clean fan or transmission while engine is running or while the transmission is hot. To prevent possible damage to seals, do not use high pressure water or steam to clean transaxle.

- Inspect cooling fan to be sure fan blades are intact and clean.

- Inspect cooling fins for dirt, grass clippings and other materials. To prevent damage to seals, do not use compressed air or high pressure sprayer to clean cooling fins.

TRANSAXLE PUMP FLUID

The transaxle was sealed at the factory and fluid maintenance is not required for the life of the transaxle. Should the transaxle ever leak or require servicing, contact a Sears or other qualified service center.

V-BELTS

Check V-belts for deterioration and wear after 100 hours of operation and replace if necessary. The belts are not adjustable. Replace belts if they begin to slip from wear.

ENGINE

LUBRICATION

Only use high quality detergent oil rated with API service classification SG-SL. Select the oil's SAE viscosity grade according to your expected operating temperature.

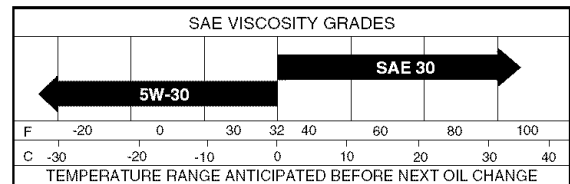

NOTE: Although multi-viscosity oils (5W30, 10W30 etc.) improve starting in cold weather, they will result in increased oil consumption when used above 32°F. Check your engine oil level more frequently to avoid possible engine damage from running low on oil.

Change the oil after every 50 hours of operation or at least once a year if the tractor is not used for 50 hours in one year.

Check the crankcase oil level before starting the engine and after each eight (8) hours of operation. Tighten oil fill cap/dipstick securely each time you check the oil level.

TO CHANGE ENGINE OIL

Determine temperature range expected before oil change. All oil must meet API service classification SG-SL.

- Be sure tractor is on level surface.
 - Oil will drain more freely when warm.
 - Catch oil in a suitable container.
1. Remove oil fill cap/dipstick. Be careful not to allow dirt to enter the engine when changing oil.
 2. Remove yellow cap from end of drain valve and install the drain tube onto the fitting.

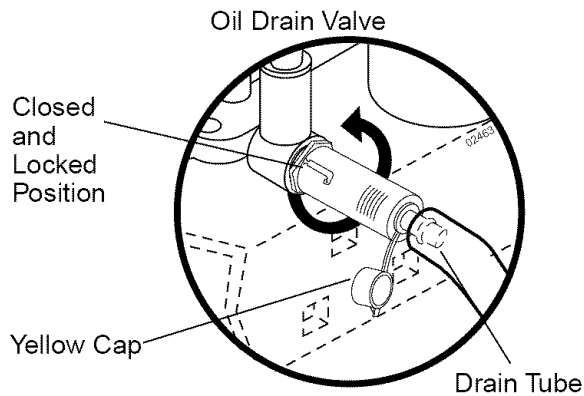

3. Unlock drain valve by pushing inward slightly and turning counterclockwise.
4. To open, pull out on the drain valve.
5. After oil has drained completely, close and lock the drain valve by pushing inward and turning clockwise until the pin is in the locked position as shown.
6. Remove the drain tube and replace the cap onto the end of the drain valve.
7. Refill engine with oil through oil fill dipstick tube. Pour slowly. Do not overfill. For approximate capacity see "PRODUCT SPECIFICATIONS" section of this manual.
8. Use gauge on oil fill cap/dipstick for checking level. For accurate reading, tighten dipstick cap securely onto the tube before removing dipstick. Keep oil at "FULL" line on dipstick. Tighten cap onto the tube securely when finished.

ENGINE OIL FILTER

Replace the engine oil filter every season or every other oil change if the tractor is used more than 100 hours in one year.

AIR FILTER

Your engine will not run properly using a dirty air filter. Replace pre-cleaner after every 25 hours of operation or every season. Service paper cartridge every 100 hours of operation or every season, whichever occurs first.

Service air cleaner more often under dusty conditions.

1. Pull up on air filter cover handle and rotate towards engine.
2. Remove cover.
3. Carefully remove air filter cartridge and pre-cleaner from base.
4. Clean base carefully to prevent debris from falling into carburetor.

NOTE: If very dirty or damaged, replace cartridge.

5. Place new pre-cleaner and cartridge firmly in base.

6. Align tabs on cover with slots in blower housing and replace cover.
7. Hook handle on cover and push down on handle to close.

IMPORTANT: Petroleum solvents, such as kerosene, are not to be used to clean the cartridge. They may cause deterioration of the cartridge. Do not oil cartridge. Do not use pressurized air to clean cartridge.

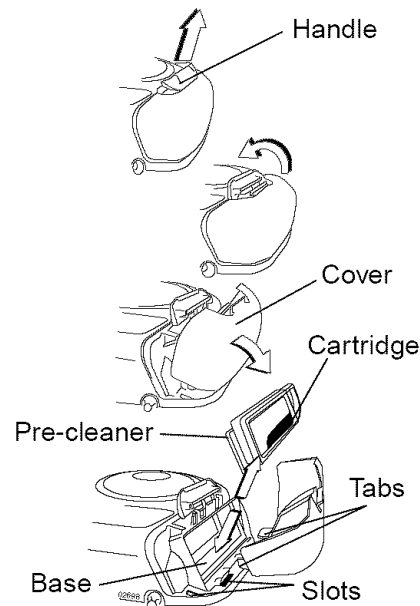

CLEAN AIR SCREEN

Air screen must be kept free of dirt and chaff to prevent engine damage from overheating. Clean with a wire brush or compressed air to remove dirt and stubborn dried gum fibers.

ENGINE COOLING SYSTEM

Debris may clog the engine's air cooling system. Remove blower housing and clean area shown to prevent overheating and engine damage.

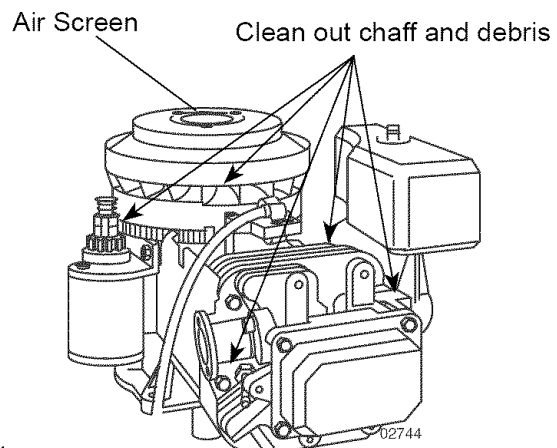

MUFFLER

Inspect and replace corroded muffler and spark arrester (if equipped) as it could create a fire hazard and/or damage.

SPARK PLUG(S)

Replace spark plug(s) at the beginning of each mowing season or after every 100 hours of operation, whichever occurs first. Spark plug type and gap setting are shown in "PRODUCT SPECIFICATIONS" section of this manual.

IN-LINE FUEL FILTER

The fuel filter should be replaced once each season. If fuel filter becomes clogged, obstructing fuel flow to carburetor, replacement is required.

1. With engine cool, remove filter and plug fuel line sections.
2. Place new fuel filter in position in fuel line with arrow pointing towards carburetor.
3. Be sure there are no fuel line leaks and clamps are properly positioned.
4. Immediately wipe up any spilled gasoline.

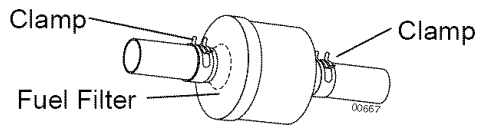

CLEANING

- Clean engine, battery, seat, finish, etc. of all foreign matter.
- Keep finished surfaces and wheels free of all gasoline, oil, etc.
- Protect painted surfaces with automotive type wax.

We do not recommend using a garden hose or pressure washer to clean your tractor unless the engine and transmission covered to keep water out. Water in engine or transmission will shorten the useful life of your tractor. Use compressed air or a leaf blower to remove grass, leaves and trash from tractor and mower.

SERVICE AND ADJUSTMENTS



WARNING: TO AVOID SERIOUS INJURY, BEFORE PERFORMING ANY SERVICE OR ADJUSTMENTS:

1. Depress clutch/brake pedal fully and set parking brake.
2. Place motion control lever in neutral (N) position.
3. Place attachment clutch in "DISENGAGED" position.
4. Turn ignition key to "STOP" and remove key.
5. Make sure the blades and all moving parts have completely stopped.
6. Disconnect spark plug wire from spark plug and place wire where it cannot come in contact with plug.

TRACTOR TO REMOVE MOWER

Mower will be easier to remove from the right side of tractor.

1. Place attachment clutch in "DISENGAGED" position.
2. Move attachment lift lever forward to lower mower to its lowest position.
3. Roll belt off engine pulley.
4. Remove small retainer spring, and remove clutch spring off pulley bolt.
5. Remove large retainer spring, slide collar off and push housing guide out of bracket.
6. Disconnect anti-sway bar from chassis bracket by removing retainer spring.
7. Disconnect suspension arms from rear deck brackets by removing retainer springs.
8. Disconnect front links from deck by removing retainer springs.
9. Raise lift lever to raise suspension arms. Slide mower out from under tractor.

IMPORTANT: If an attachment other than the mower deck is to be mounted on the tractor, remove the front links and hook the clutch spring into square hole in frame.

TO INSTALL MOWER

1. Raise attachment lift lever to its highest position.
2. Slide mower under tractor with deflector shield to right side of tractor.
3. Lower lift lever to its lowest position.
4. Connect front links to mower deck and secure with retainer springs.
5. Connect suspension arms to rear deck brackets and secure with retainer springs.
6. Connect anti-sway bar to chassis bracket and secure with retainer spring.
7. Push clutch cable housing guide into bracket, slide collar onto guide and secure with large retainer spring.

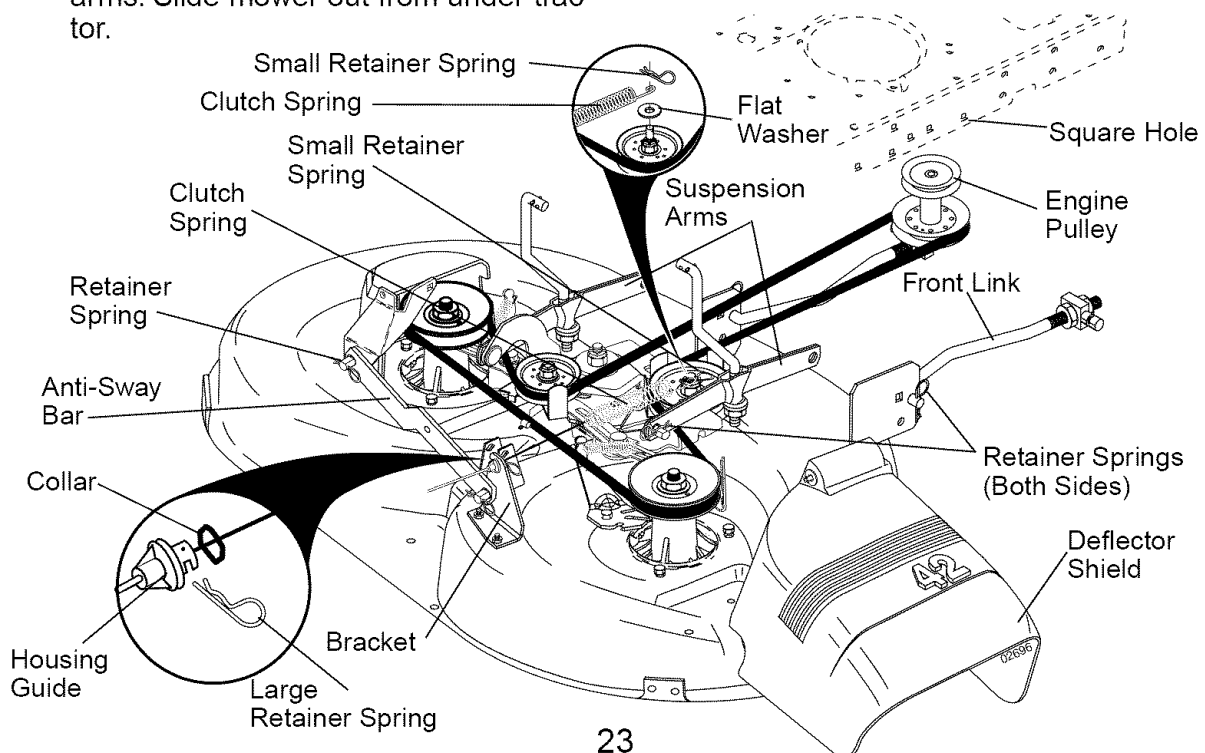

8. Place flat washer and clutch spring on idler pulley bolt and secure with small retainer spring.
9. Install belt onto engine pulley.

TO LEVEL MOWER HOUSING

Adjust the mower while tractor is parked on level ground or driveway. Make sure tires are properly inflated (See "PRODUCT SPECIFICATIONS" section of this manual). If tires are over or underinflated, you will not properly adjust your mower.

SIDE-TO-SIDE ADJUSTMENT

- Raise mower to its highest position.
- At the midpoint of both sides of mower, measure height from bottom edge of mower to ground. Distance "A" on both sides of mower should be the same or within 1/4" of each other.
- If adjustment is necessary, make adjustment on one side of mower only.
- To raise one side of mower, tighten lift link adjustment nut on that side.
- To lower one side of mower, loosen lift link adjustment nut on that side.

NOTE: Each full turn of adjustment nut will change mower height about 1/8".

- Recheck measurements after adjusting.

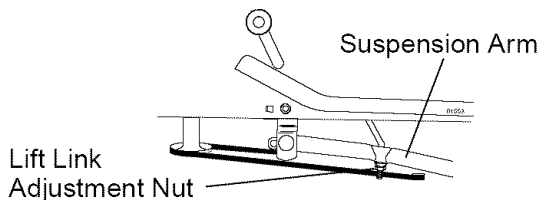
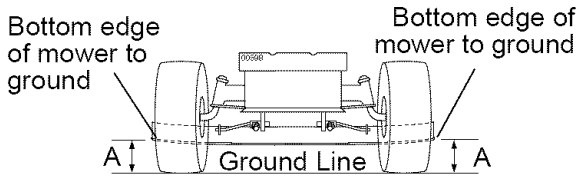

FRONT-TO-BACK ADJUSTMENT

IMPORTANT: Deck must be level side-to-side. If the following front-to-back adjustment is necessary, be sure to adjust both front links equally so mower will stay level side-to-side.

To obtain the best cutting results, the mower housing should be adjusted so that the front is approximately 1/8" to 1/2" lower than the rear when the mower is in its highest position.

Check adjustment on right side of tractor. Measure distance "D" directly in front and behind the mandrel at bottom edge of mower housing as shown.

- Before making any necessary adjustments, check that both front links are equal in length.

- If links are not equal in length, adjust one link to same length as other link.
- To lower front of mower loosen nut "E" on both front links an equal number of turns.
- When distance "D" is 1/8" to 1/2" lower at front than rear, tighten nuts "F" against trunnion on both front links.
- To raise front of mower, loosen nut "F" from trunnion on both front links. Tighten nut "E" on both front links an equal number of turns. The two front links must remain equal in length.
- When distance "D" is 1/8" to 1/2" lower at front than rear, tighten nut "F" against trunnion on both front links.
- Recheck side-to-side adjustment.

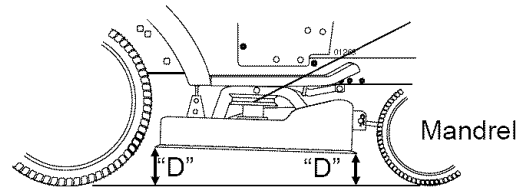

Both Front Links Should be Equal in Length

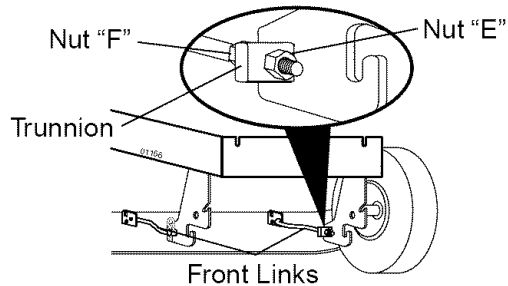
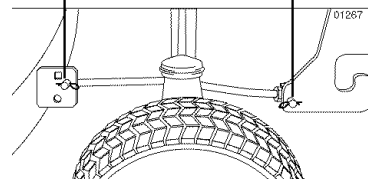

TO REPLACE MOWER BLADE DRIVE BELT

The mower blade drive belt may be replaced without tools. Park the tractor on level surface. Engage parking brake.

BELT REMOVAL -

1. Remove mower from tractor (See "TO REMOVE MOWER" in this section of manual).
2. Work belt off both mandrel pulleys and idler pulleys.
3. Pull belt away from mower.

BELT INSTALLATION -

1. Work belt around both mandrel pulleys and idler pulleys
2. Make sure belt is in all pulley grooves and inside all belt guides.

3. Install mower (See "To Install Mower" in this section of this manual).

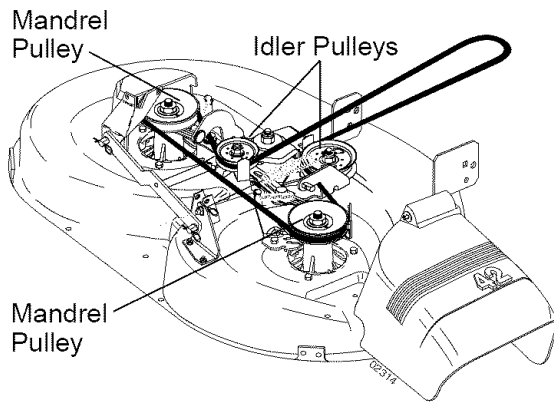

TO CHECK AND ADJUST BRAKE

Your tractor is equipped with an adjustable brake system which is mounted on the right side of the transaxle.

If tractor requires more than five (5) feet to stop at highest speed in highest gear on a level, dry concrete or paved surface, then brake must be checked and adjusted.

TO CHECK BRAKE

1. Park tractor on a level, dry concrete or paved surface, depress clutch/brake pedal all the way down and engage parking brake.
2. Disengage transmission by placing freewheel control in "transmission disengaged" position. Pull freewheel control out and into the slot and release so it is held in the disengaged position.

The rear wheels must lock and skid when you try to manually push the tractor forward. If the rear wheels rotate, the brake needs to be adjusted or the pads need to be replaced.

TO ADJUST BRAKE

1. Depress clutch/brake pedal all the way down and engage parking brake.
2. Measure distance between brake operating arm and nut "A" on brake rod.
3. If distance is other than 1-9/16", loosen jam nut and turn nut "A" until distance becomes 1-9/16". Retighten jam nut against nut "A".
4. Engage transmission by placing freewheel control in "transmission engaged" position.
5. Road test tractor for proper stopping distance as stated above. Readjust if necessary. If stopping distance is still greater than five (5) feet in highest gear, further maintenance is necessary. Replace brake pads or contact a Sears or other qualified service center.

With parking brake "Engaged"

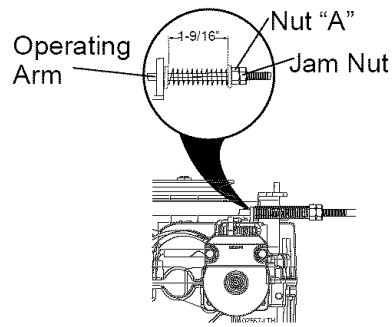

TO REPLACE MOTION DRIVE BELT

Park the tractor on level surface. Engage parking brake. For assistance, there is a belt installation guide decal on bottom side of left footrest.

BELT REMOVAL -

1. Remove mower (See "TO REMOVE MOWER" in this section of manual).
- NOTE:** Observe entire motion drive belt and position of all belt guides and keepers.
2. Remove belt from stationary idler and clutching idler.
3. Remove belt downward from around engine pulley.
4. Pull belt slack toward rear of tractor. Carefully remove belt upwards from transmission input pulley.
5. Remove belt from center span keeper and pull belt away from tractor.

BELT INSTALLATION -

1. Carefully work new belt down onto the input pulley.
2. Slide belt into the center span keeper.
3. Pull belt toward front of tractor and roll around the top groove of engine pulley.
4. Install belt through stationary idler and clutching idler.
5. Make sure belt is in all pulley grooves and inside all belt guides and keepers.
6. Install mower (See "TO INSTALL MOWER" in this section of manual).

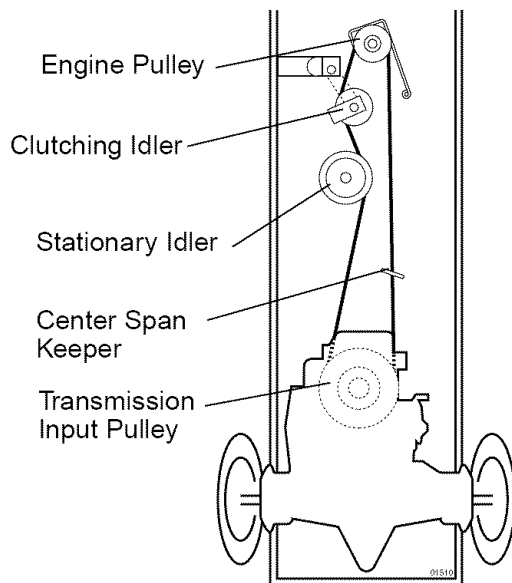

TRANSAXLE MOTION CONTROL LEVER NEUTRAL ADJUSTMENT

The motion control lever has been preset at the factory and adjustment should not be necessary.

1. Loosen adjustment bolt in front of the right rear wheel, and lightly tighten.
2. Start engine and move motion control lever until tractor does not move forward or backward.
3. Hold motion control lever in that position and turn engine off.
4. While holding motion control lever in place, loosen the adjustment bolt.
5. Move motion control lever to the neutral (N) (lock gate) position.
6. Tighten adjustment bolt securely.

NOTE: If additional clearance is needed to get to adjustment bolt, move mower deck height to the lowest position.

After above adjustment is made, if the tractor still creeps forward or backward while motion control lever is in neutral position, follow these steps:

1. Loosen the adjustment bolt.
2. Move the motion control lever 1/4 to 1/2 inch in the direction it is trying to creep.
3. Tighten adjustment bolt securely.
4. Start engine and test.
5. If tractor still creeps, repeat above steps until satisfied.

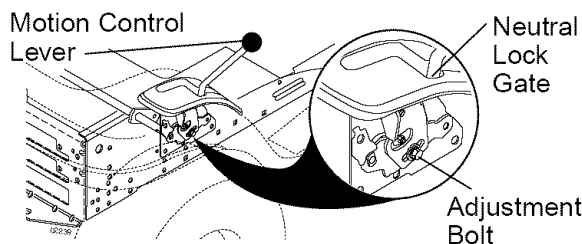

TRANSMISSION REMOVAL/REPLACEMENT

Should your transmission require removal for service or replacement, it should be purged after reinstallation and before operating the tractor. See "PURGE TRANSMISSION" in the Operation section of this manual.

TO ADJUST STEERING WHEEL ALIGNMENT

If steering wheel crossbars are not horizontal (left to right) when wheels are positioned straight forward, remove steering wheel and reassemble with crossbars horizontal. Tighten securely.

FRONT WHEEL TOE-IN/CAMBER

The front wheel toe-in and camber are not adjustable on your tractor. If damage has occurred to affect the front wheel toe-in or camber, contact a Sears or other qualified service center.

TO REMOVE WHEEL FOR REPAIRS

1. Block up axle securely.
 2. Remove axle cover, retaining ring and washers to allow wheel removal (rear wheels have a square key - Do not lose).
 3. Repair tire and reassemble.
- NOTE:** On rear wheels only: align grooves in rear wheel hub and axle. Insert square key.
4. Replace washers and snap retaining ring securely in axle groove.
 5. Replace axle cover.

NOTE: To seal tire punctures and prevent flat tires due to slow leaks, purchase and use tire sealant from Sears. Tire sealant also prevents tire dry rot and corrosion.

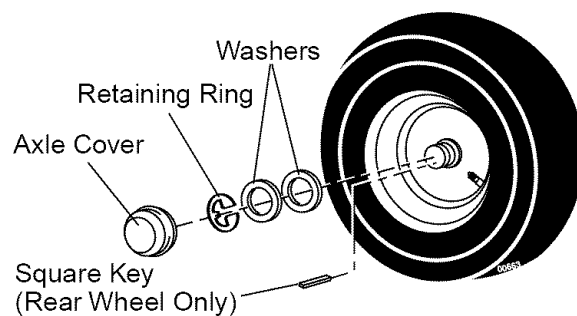

TO START ENGINE WITH A WEAK BATTERY

WARNING: Lead-acid batteries generate explosive gases. Keep sparks, flame and smoking materials away from batteries. Always wear eye protection when around batteries.

If your battery is too weak to start the engine, it should be recharged. (See "BATTERY" in the MAINTENANCE section of this manual).

If "jumper cables" are used for emergency starting, follow this procedure:

IMPORTANT: Your tractor is equipped with a 12 volt system. The other vehicle must also be a 12 volt system. Do not use your tractor battery to start other vehicles.

TO ATTACH JUMPER CABLES -

1. Connect one end of the RED cable to the POSITIVE (+) terminal of each battery(A-B), taking care not to short against tractor chassis.
2. Connect one end of the BLACK cable to the NEGATIVE (-) terminal (C) of fully charged battery.
3. Connect the other end of the BLACK cable (D) to good chassis ground, away from fuel tank and battery.

TO REMOVE CABLES, REVERSE ORDER -

1. BLACK cable first from chassis and then from the fully charged battery.
2. RED cable last from both batteries.

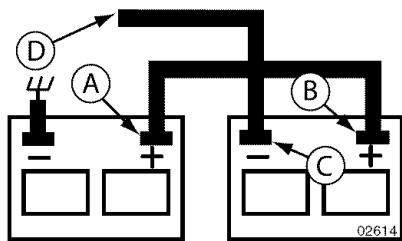

Weak or Dead Battery Fully Charged Battery

REPLACING BATTERY

⚠WARNING: Do not short battery terminals by allowing a wrench or any other object to contact both terminals at the same time. Before connecting battery, remove metal bracelets, wristwatch bands, rings, etc.

Positive terminal must be connected first to prevent sparking from accidental grounding.

1. Lift seat pan to raised position.
2. Disconnect BLACK battery cable first then RED battery cable and carefully remove battery from tractor.
3. Install new battery with terminals in same position as old battery.
4. First connect RED battery cable to positive (+) terminal with hex bolt and keps nut as shown. Tighten securely. Slide terminal cover over terminal
5. Connect BLACK grounding cable to negative (-) terminal with remaining hex bolt and keps nut. Tighten securely.

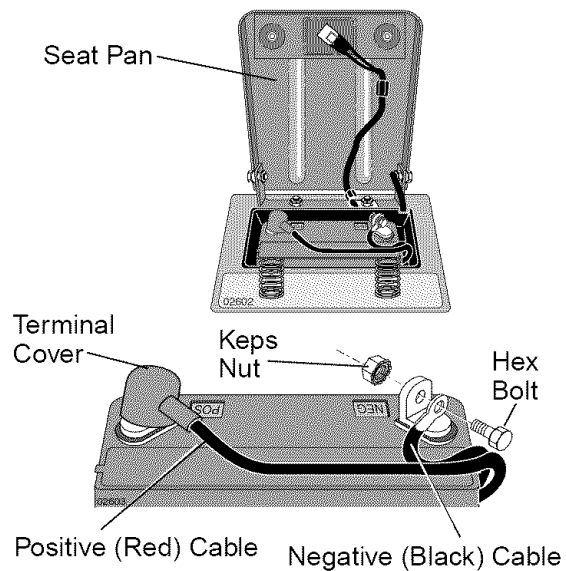

TO REPLACE HEADLIGHT BULB

1. Raise hood.
2. Pull bulb holder out of the hole in the backside of the grill.
3. Replace bulb in holder and push bulb holder securely back into the hole in the backside of the grill.
4. Close hood.

INTERLOCKS AND RELAYS

Loose or damaged wiring may cause your tractor to run poorly, stop running, or prevent it from starting.

- Check wiring. See electrical wiring diagram in the Repair Parts section.

TO REPLACE FUSE

Replace with 20 amp automotive-type plug-in fuse. The fuse holder is located behind the dash.

TO REMOVE HOOD AND GRILL ASSEMBLY

1. Raise hood.
2. Unsnap headlight wire connector.
3. Stand in front of tractor. Grasp hood at sides, tilt toward engine and lift off of tractor.
4. When replacing hood, be sure to re-connect the headlight wire connector.

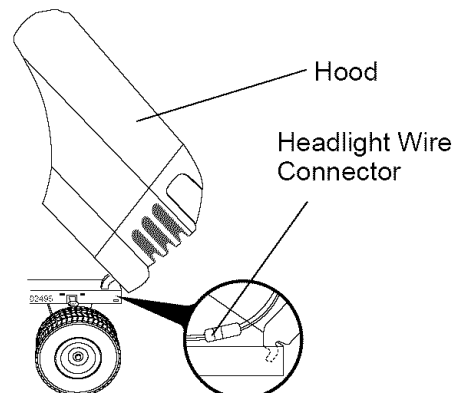

ENGINE

Maintenance, repair, or replacement of the emission control devices and systems, which are being done at the customer's expense, may be performed by any non-road engine repair establishment or individual. Warranty repairs must be performed by an authorized engine manufacturer's service outlet.

TO ADJUST THROTTLE CONTROL CABLE

The throttle control has been preset at the factory and adjustment should not be necessary. Check adjustment as described below before loosening cable. If adjustment is necessary, proceed as follows:

1. With engine not running, move throttle control lever from slow to choke position. Slowly move lever from choke to fast position.
2. Check that holes "A" in governor control lever and hole in governor plate line-up. If holes "A" are not aligned, loosen clamp screw and move throttle cable until holes are aligned. Tighten clamp screw securely.

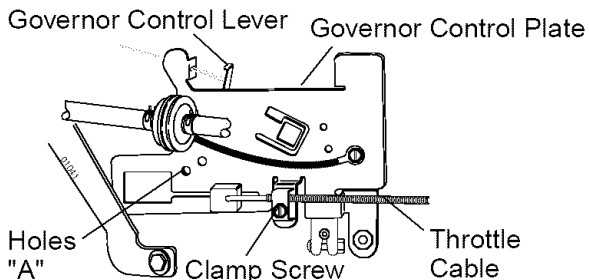

TO ADJUST CARBURETOR

NOTE: The carburetor on this engine is low emission. It is equipped with an idle fuel adjusting needle with a limiter cap, which allows some adjustment within the limits allowed by the cap. Do not attempt to remove the limiter cap. The limiter cap cannot be removed without breaking the adjusting needle.

The carburetor has been preset at the factory and adjustment should not be necessary. However, minor adjustment may be required to compensate for differences in fuel, temperature, altitude or load. If the carburetor does need adjustment, proceed as follows:

In general, turning idle mixture valve **in** (clockwise) decreases the supply of fuel to the engine giving a leaner fuel/air mixture. Turning the idle mixture valve **out** (counterclockwise) increases the supply of fuel to the engine giving a richer fuel/air mixture.

IMPORTANT: Damage to the needle valve and the seat in carburetor may result if screw is turned in too tight.

PRELIMINARY SETTING -

1. Air cleaner assembly must be assembled to the carburetor when making carburetor adjustments.
2. Be sure the throttle control cable is adjusted properly (see above).

FINAL SETTING -(See "TO ADJUST THROTTLE CONTROL CABLE" in this section of the manual.)

1. Start engine and allow to warm for five minutes. Make final adjustments with engine running and shift/motion control lever in neutral (**N**) position.
2. Move throttle control lever to slow position. With finger, rotate and hold throttle lever against idle speed screw. Turn idle speed screw to attain 1750 RPM.
3. While still holding throttle lever against idle speed screw, turn idle mixture valve full travel clockwise then counterclockwise until engine runs rough. Turn valve to a point midway between those two positions. Release throttle lever.

ACCELERATION TEST -

4. Move throttle control lever from slow to fast position. If engine hesitates or dies, turn idle mixture valve **out** (counterclockwise) 1/8 turn. Repeat test and continue to adjust, if necessary, until engine accelerates smoothly.

High speed stop is factory adjusted. Do not adjust or damage may result.

IMPORTANT: Never tamper with the engine governor, which is factory set for proper engine speed. Overspeeding the engine above the factory high speed setting can be dangerous. If you think the engine-governed high speed needs adjusting, contact a Sears or other qualified service center, which has proper equipment and experience to make any necessary adjustments.

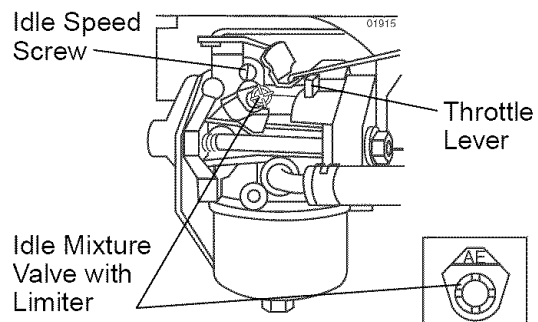

STORAGE

Immediately prepare your tractor for storage at the end of the season or if the tractor will not be used for 30 days or more.

CAUTION: Never store the tractor with gasoline in the tank inside a building where fumes may reach an open flame or spark. Allow the engine to cool before storing in any enclosure.

TRACTOR

Remove mower from tractor for winter storage. When mower is to be stored for a period of time, clean it thoroughly, remove all dirt, grease, leaves, etc. Store in a clean, dry area.

1. Clean entire tractor (See "CLEANING" in the Maintenance section of this manual).
2. Inspect and replace belts, if necessary (See belt replacement instructions in the Service and Adjustments section of this manual).
3. Lubricate as shown in the Maintenance section of this manual.
4. Be sure that all nuts, bolts and screws are securely fastened. Inspect moving parts for damage, breakage and wear. Replace if necessary.
5. Touch up all rusted or chipped paint surfaces; sand lightly before painting.

BATTERY

- Fully charge the battery for storage.
- After a period of time in storage, battery may require recharging.
- To help prevent corrosion and power leakage during long periods of storage, battery cables should be disconnected and battery cleaned thoroughly (see "TO CLEAN BATTERY AND TERMINALS" in the Maintenance section of this manual).
- After cleaning, leave cables disconnected and place cables where they cannot come in contact with battery terminals.
- If battery is removed from tractor for storage, do not store battery directly on concrete or damp surfaces.

ENGINE

FUEL SYSTEM

IMPORTANT: It is important to prevent gum deposits from forming in essential fuel system parts such as carburetor, fuel

hose, or tank during storage. Also, alcohol blended fuels (called gasohol or using ethanol or methanol) can attract moisture which leads to separation and formation of acids during storage. Acidic gas can damage the fuel system of an engine while in storage.

- Empty the fuel tank by starting the engine and letting it run until the fuel lines and carburetor are empty.
- Never use engine or carburetor cleaner products in the fuel tank or permanent damage may occur.
- Use fresh fuel next season.

NOTE: Fuel stabilizer is an acceptable alternative in minimizing the formation of fuel gum deposits during storage. Add stabilizer to gasoline in fuel tank or storage container. Always follow the mix ratio found on stabilizer container. Run engine at least 10 minutes after adding stabilizer to allow the stabilizer to reach the carburetor. Do not empty the gas tank and carburetor if using fuel stabilizer.

ENGINE OIL

Drain oil (with engine warm) and replace with clean engine oil. (See "ENGINE" in the Maintenance section of this manual).

CYLINDER(S)

1. Remove spark plug(s).
2. Pour one ounce of oil through spark plug hole(s) into cylinder(s).
3. Turn ignition key to "START" position for a few seconds to distribute oil.
4. Replace with new spark plug(s).

OTHER

- Do not store gasoline from one season to another.
- Replace your gasoline can if your can starts to rust. Rust and/or dirt in your gasoline will cause problems.
- If possible, store your tractor indoors and cover it to give protection from dust and dirt.
- Cover your tractor with a suitable protective cover that does not retain moisture. Do not use plastic. Plastic cannot breathe which allows condensation to form and will cause your tractor to rust.

IMPORTANT: Never cover tractor while engine and exhaust areas are still warm.

TROUBLESHOOTING CHART:

See appropriate section in manual unless directed to Sears service center

PROBLEM	CAUSE	CORRECTION
Will not start	<ol style="list-style-type: none"> 1. Out of fuel. 2. Engine not "CHOKED" properly. 3. Engine flooded. 4. Bad spark plug. 5. Dirty air filter. 6. Dirty fuel filter. 7. Water in fuel. 8. Loose or damaged wiring. 9. Carburetor out of adjustment. 10. Engine valves out of adjustment. 	<ol style="list-style-type: none"> 1. Fill fuel tank. 2. See "TO START ENGINE" in Operation section. 3. Wait several minutes before attempting to start. 4. Replace spark plug. 5. Clean/replace air filter. 6. Replace fuel filter. 7. Empty fuel tank and carburetor, refill tank with fresh gasoline and replace fuel filter. 8. Check all wiring. 9. See "To Adjust Carburetor" in Service and Adjustments section. 10. Contact a Sears or other qualified service center.
Hard to start	<ol style="list-style-type: none"> 1. Dirty air filter. 2. Bad spark plug. 3. Weak or dead battery. 4. Dirty fuel filter. 5. Stale or dirty fuel. 6. Loose or damaged wiring. 7. Carburetor out of adjustment. 8. Engine valves out of adjustment. 	<ol style="list-style-type: none"> 1. Clean/replace air filter. 2. Replace spark plug. 3. Recharge or replace battery. 4. Replace fuel filter. 5. Empty fuel tank and refill tank with fresh, clean gasoline. 6. Check all wiring. 7. See "To Adjust Carburetor" in Service and Adjustments section. 8. Contact a Sears or other qualified service center.
Engine will not turn over	<ol style="list-style-type: none"> 1. Brake pedal not depressed. 2. Attachment clutch is engaged. 3. Weak or dead battery. 4. Blown fuse. 5. Corroded battery terminals. 6. Loose or damaged wiring. 7. Faulty ignition switch. 8. Faulty solenoid or starter. 9. Faulty operator presence switch(es). 	<ol style="list-style-type: none"> 1. Depress brake pedal. 2. Disengage attachment clutch. 3. Recharge or replace battery. 4. Replace fuse. 5. Clean battery terminals. 6. Check all wiring. 7. Check/replace ignition switch. 8. Check/replace solenoid or starter. 9. Contact a Sears or other qualified service center.
Engine clicks but will not start	<ol style="list-style-type: none"> 1. Weak or dead battery. 2. Corroded battery terminals. 3. Loose or damaged wiring. 4. Faulty solenoid or starter. 	<ol style="list-style-type: none"> 1. Recharge or replace battery. 2. Clean battery terminals. 3. Check all wiring. 4. Check/replace solenoid or starter.
Loss of power	<ol style="list-style-type: none"> 1. Cutting too much grass/too fast. 2. Throttle in "CHOKE" position. 3. Build-up of grass, leaves and trash under mower. 4. Dirty air filter. 5. Low oil level/dirty oil. 	<ol style="list-style-type: none"> 1. Raise cutting height/reduce speed. 2. Adjust throttle control. 3. Clean underside of mower housing. 4. Clean/replace air filter. 5. Check oil level/change oil.

TROUBLESHOOTING CHART:

See appropriate section in manual unless directed to Sears service center

PROBLEM	CAUSE	CORRECTION
Loss of power (cont.)	<ul style="list-style-type: none"> 6. Faulty spark plug. 7. Dirty fuel filter. 8. Stale or dirty fuel. 9. Water in fuel. 10. Spark plug wire loose. 11. Dirty engine air screen/fins. 12. Dirty/clogged muffler. 13. Loose or damaged wiring. 14. Carburetor out of adjustment. 15. Engine valves out of adjustment. 	<ul style="list-style-type: none"> 6. Clean and regap or change spark plug. 7. Replace fuel filter. 8. Empty fuel tank and refill tank with fresh, clean gasoline. 9. Empty fuel tank and carburetor, refill tank with fresh gasoline and replace fuel filter. 10. Connect and tighten spark plug wire. 11. Clean engine air screen/fins. 12. Clean/replace muffler. 13. Check all wiring. 14. See "To Adjust Carburetor" in Service and Adjustments section. 15. Contact a Sears or other qualified service center.
Excessive vibration	<ul style="list-style-type: none"> 1. Worn, bent or loose blade. 2. Bent blade mandrel. 3. Loose/damaged part(s). 	<ul style="list-style-type: none"> 1. Replace blade. Tighten blade bolt. 2. Contact a Sears or other qualified service center. 3. Tighten loose part(s). Replace damaged parts.
Engine dies when tractor is shifted into reverse	<ul style="list-style-type: none"> 1. Reverse operation system (ROS) is not "ON" while mower or other attachment is engaged. 	<ul style="list-style-type: none"> 1. Turn ignition key to ROS "ON" position. See Operation section.
Engine continues to run when operator leaves seat with attachment clutch engaged	<ul style="list-style-type: none"> 1. Faulty operator-safety presence control system. 	<ul style="list-style-type: none"> 1. Check wiring, switches and connections. If not corrected, contact a Sears or other qualified service center.
Poor cut - uneven	<ul style="list-style-type: none"> 1. Worn, bent or loose blade. 2. Mower deck not level. 3. Buildup of grass, leaves, and trash under mower. 4. Bent blade mandrel. 5. Clogged mower deck vent from build-up of grass, leaves, and trash around mandrels. 	<ul style="list-style-type: none"> 1. Replace blade. Tighten blade bolt. 2. Level mower deck. 3. Clean underside of mower housing. 4. Contact a Sears or other qualified service center. 5. Clean around mandrels to open vent holes.

TROUBLESHOOTING CHART:

See appropriate section in manual unless directed to Sears service center

PROBLEM	CAUSE	CORRECTION
Mower blades will not rotate	<ol style="list-style-type: none"> 1. Obstruction in clutch mechanism. 2. Worn/damaged mower drive belt. 3. Frozen idler pulley. 4. Frozen blade mandrel. 	<ol style="list-style-type: none"> 1. Remove obstruction. 2. Replace mower drive belt. 3. Replace idler pulley. 4. Contact a Sears or other qualified service center.
Poor grass discharge Poor grass discharge (continued)	<ol style="list-style-type: none"> 1. Engine speed too slow. 2. Travel speed too fast. 3. Wet grass. 4. Mower deck not level. 5. Low/uneven tire air pressure. 6. Worn, bent or loose blade. 7. Buildup of grass, leaves and trash under mower. 8. Mower drive belt worn. 9. Blades improperly installed. 10. Improper blades used. 11. Clogged mower deck vent holes from buildup of grass, leaves, and trash around mandrels. 	<ol style="list-style-type: none"> 1. Place throttle control in "FAST" position. 2. Shift to slower speed. 3. Allow grass to dry before mowing. 4. Level mower deck. 5. Check tires for proper air pressure. 6. Replace/sharpen blade. Tighten blade bolt. 7. Clean underside of mower housing. 8. Replace mower drive belt. 9. Reinstall blades sharp edge down. 10. Replace with blades listed in this manual. 11. Clean around mandrels to open vent holes.
Headlight(s) not working (if so equipped)	<ol style="list-style-type: none"> 1. Light switch is "OFF". 2. Bulb(s) or lamp(s) burned out. 3. Faulty light switch. 4. Loose or damaged wiring. 5. Blown fuse. 	<ol style="list-style-type: none"> 1. Turn light switch "ON". 2. Replace bulb(s) or lamp(s). 3. Check/replace light switch. 4. Check wiring and connections. 5. Replace fuse.
Battery will not charge	<ol style="list-style-type: none"> 1. Bad battery cell(s). 2. Poor cable connections. 3. Faulty regulator (if so equipped). 4. Faulty alternator. 	<ol style="list-style-type: none"> 1. Replace battery. 2. Check/clean all connections. 3. Replace regulator. 4. Replace alternator.
Loss of drive	<ol style="list-style-type: none"> 1. Freewheel control in "disengaged" position. 2. Motion drive belt worn, damaged, or broken. 3. Air trapped in transmission during shipment or servicing. 	<ol style="list-style-type: none"> 1. Place freewheel control in "engaged" position. 2. Replace motion drive belt. 3. Purge transmission.
Engine "backfires" when turning engine "OFF"	<ol style="list-style-type: none"> 1. Engine throttle control not set between half and full speed (fast) position before stopping engine. 	<ol style="list-style-type: none"> 1. Move throttle control between half and full speed (fast) position before stopping engine.

TRACTOR - - MODEL NUMBER 917.274760

SCHEMATIC

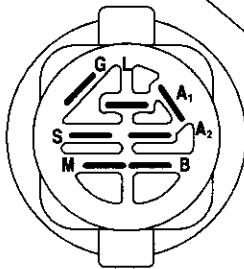
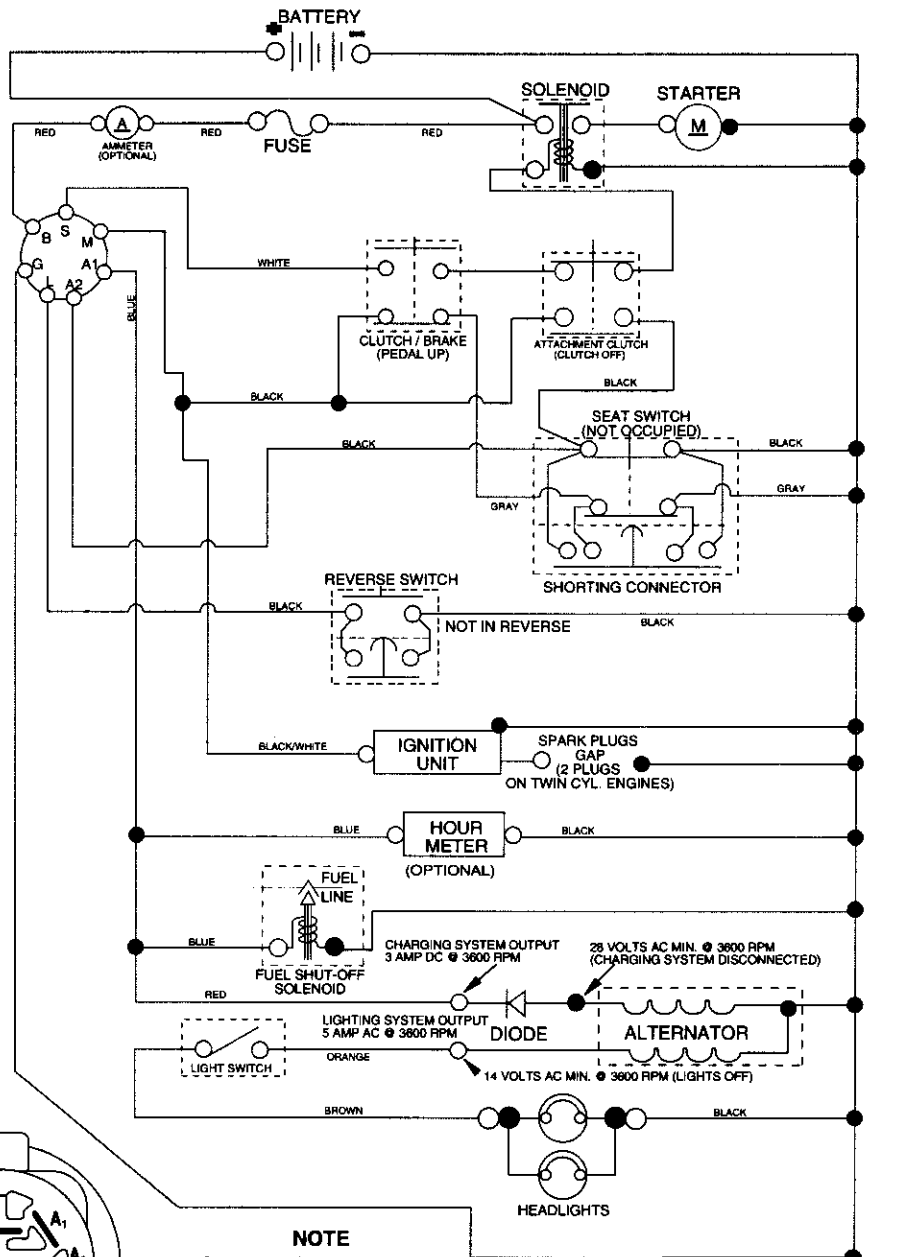

POSITION	CIRCUIT	"MAKE"
OFF	M+G+A1	
RUN/OVERRIDE	B+A1	
RUN	B+A1	L+A2
START	B + S + A1	

NOTE
 YOUR TRACTOR IS EQUIPPED WITH A SPECIAL ALTERNATOR SYSTEM. THE LIGHTS ARE NOT CONNECTED TO THE BATTERY, BUT HAVE THEIR OWN ELECTRICAL SOURCE. BECAUSE OF THIS, THE BRIGHTNESS OF THE LIGHTS WILL CHANGE WITH ENGINE SPEED. AT IDLE THE LIGHTS WILL DIM. AS THE ENGINE IS SPEEDED UP, THE LIGHTS WILL BECOME THEIR BRIGHTEST.



WIRING INSULATED CLIPS
NOTE: IF WIRING INSULATED CLIPS WERE REMOVED FOR SERVICING OF UNIT, THEY SHOULD BE REPLACED TO PROPERLY SECURE YOUR WIRING.

02831

REPAIR PARTS

TRACTOR - - MODEL NUMBER 917.274760

ELECTRICAL

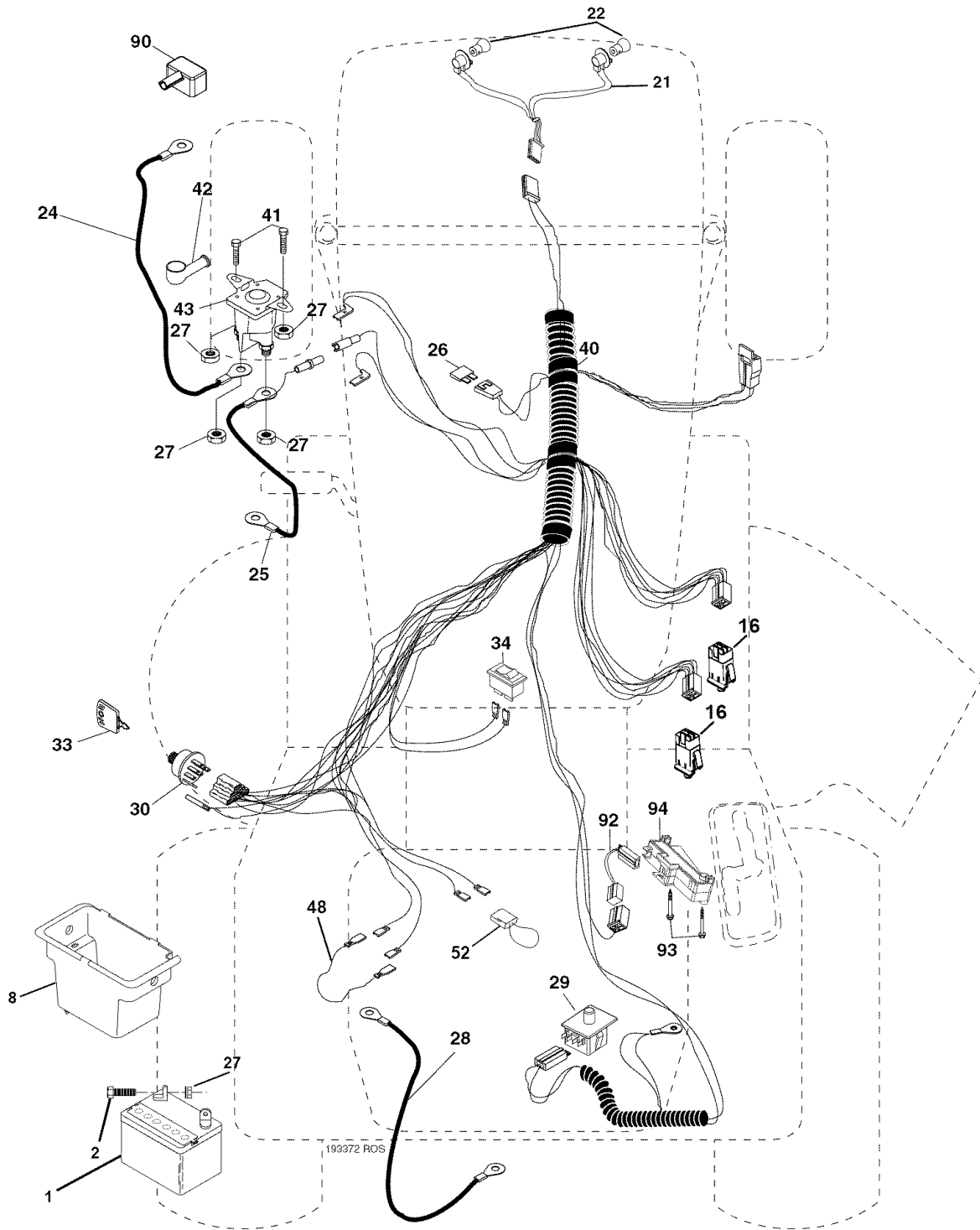

ELECTRICAL

TRACTOR - - MODEL NUMBER 917.274760

KEY NO.	PART NO.	DESCRIPTION
1	163465	Battery
2	74760412	Bolt Hex Hd 1/4-20 unc x 3/4
8	176689	Box Battery
16	176138	Switch, Interlock
21	183759	Harness Asm Light W/4152j
22	4152J	Bulb Light #1156
24	4799J	Cable Battery 6 Ga. 11" red
25	193149	Cable Battery
26	175158	Fuse
27	73510400	Nut Keps Hex 1/4-20 Unc
28	4207J	Cable Ground 6 Ga. 12" black
29	192749	Switch Seat DP w/ramps
30	193350	Switch Ign
33	140403	Key Ign
34	110712X	Switch Light
40	193372	Harness Ign
41	71110408	Bolt Blk. Fin Hex 1/4-20 unc x 1/2
42	131563	Cover Terminal Red
43	178861	Solenoid
48	140844	Adapter Ammeter
52	141940	Protection Wire Loop
90	180449	Cover Terminal
92	193465	Harness Pigtail Reverse Switch
93	192540	Screw Plastic 10-14 x 2.0
94	191834	Module Reverse ROS

NOTE: All component dimensions given in U.S. inches
1 inch = 25.4 mm

TRACTOR - - MODEL NUMBER 917.274760

CHASSIS AND ENCLOSURES

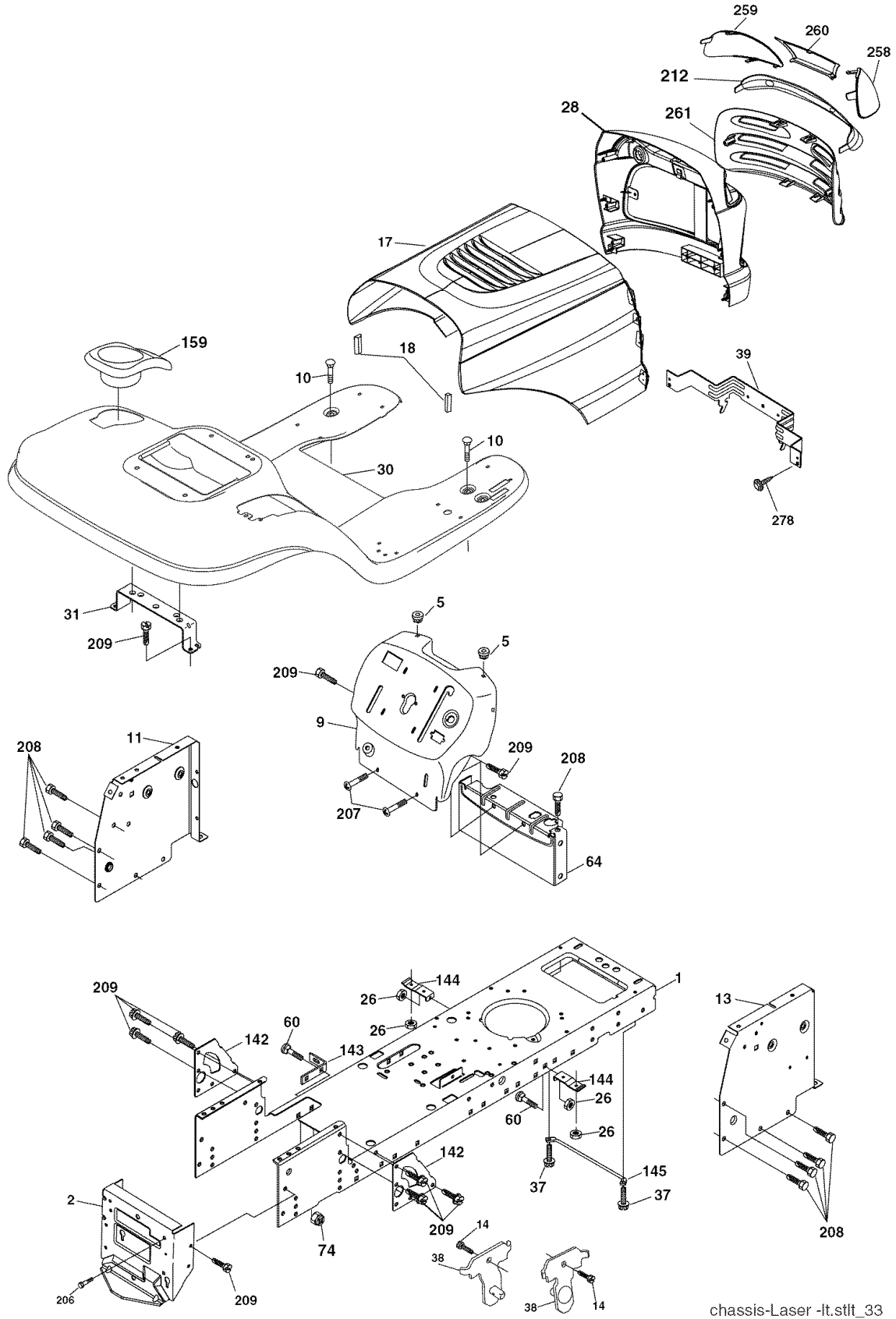

chassis-Laser -lt.stft_33

TRACTOR - - MODEL NUMBER 917.274760
CHASSIS AND ENCLOSURES

KEY NO.	PART NO.	DESCRIPTION
1	174619	Chassis
2	176554	Drawbar
3	17060612	Screw 3/8-16 x 3/4
5	155272	Bumper Hood/Dash
9	193510X012	Dash
10	STD533710	Bolt, Carriage 3/8-16 x 3/4
11	174996	Panel, Dash, L.H.
13	172105X010	Panel, Dash, R.H.
14	17490608	Screw Thdrol 3/8-16 x 1/2
17	185682X613	Hood Assembly
18	184921	Bumper Hood
26	STD541437	Nut
28	184247	Grille/Lens Asm. (Includes Key Nos. 212, 258, 259, and 260)
30	187845X012	Fend/Ftrest
31	139976	Bracket, Fender Support
37	17490508	Screw Thdrol 5/16-18 x 1/2
38	175710	Pivot Bracket Assembly, Rear
39	174714	Bracket Pivot Laser Lt
60	72140606	Bolt Rdhd Sqnk 3/8-16 unc x 1
64	154798	Dash Lower STLT
74	STD541437	Nut Crownlock 3/8-16 unc
142	175702	Plate Reinforcement STLT
143	186689	Bracket Swaybar Chassis
144	175582	Bracket Pnt Footrest STLT
145	156524	Rod Pivot Chassis/Hood
159	155123X428	Cupholder Stlt Black
206	170165	Bolt Shoulder 5/16-18 TT
207	17670508	Screw Thdrol 5/16-18 x 1/2 Tytt
208	17670608	Screw Thdrol 3/8-16 x 1/2
209	17000612	Screw Hexwsh Thdr 3/8-16 x 3/4
212	184248	Insert Lens Reflective
258	184245X599	Lens Laser RH
259	184246X599	Lens Laser LH
260	184250X428	Cover Lens Laser
261	184258X428	Insert Grille Laser
278	191611	Screw 10 x 3/4 Single Lead-Hex
--	5479J	Plug, Button
--	187801	Plug Plastic Dome

NOTE: All component dimensions given in U.S. inches
1 inch = 25.4 mm

TRACTOR - - MODEL NUMBER 917.274760

GROUND DRIVE

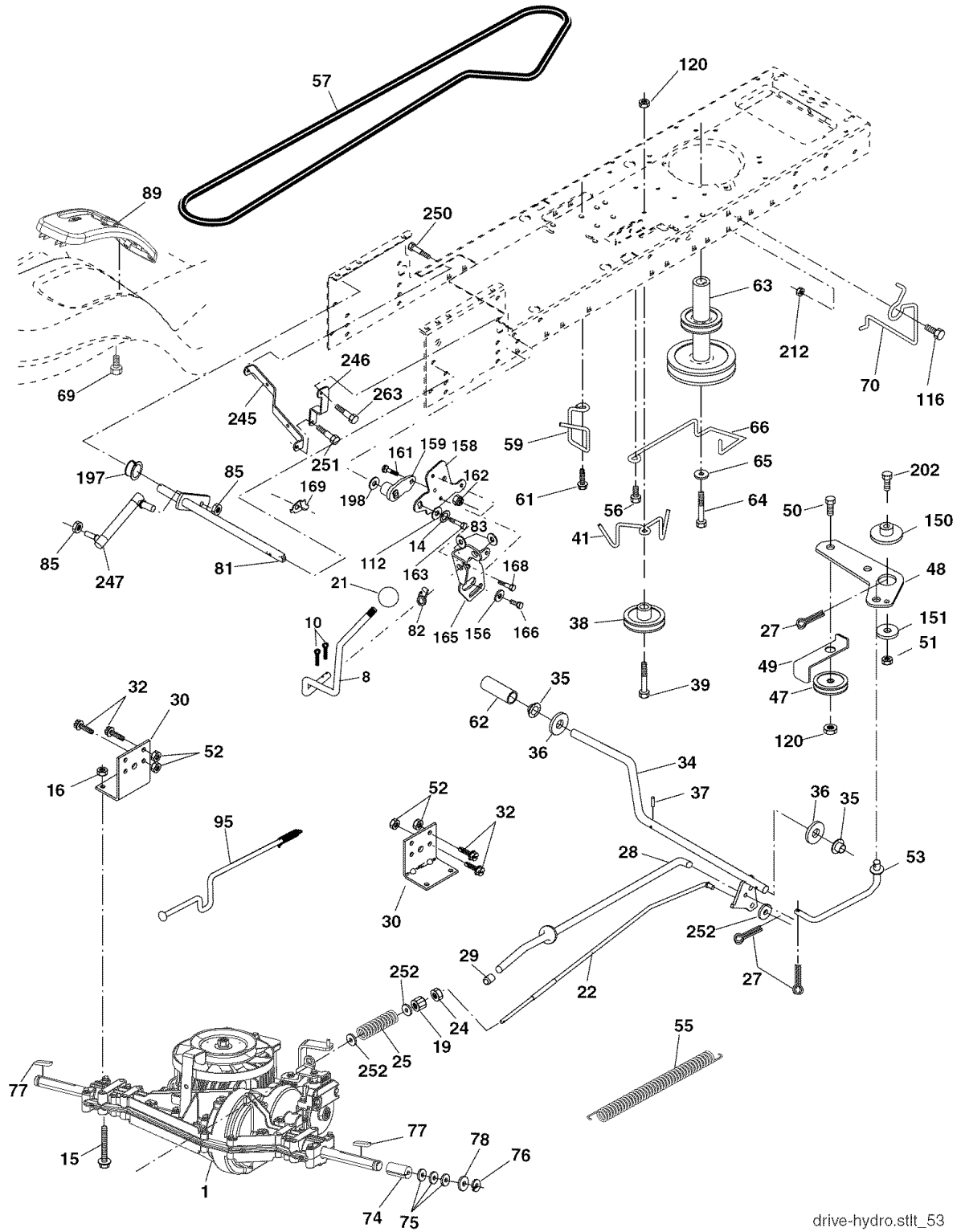

drive-hydro.stlt_53

TRACTOR - - MODEL NUMBER 917.274760

GROUND DRIVE

KEY NO.	PART NO.	DESCRIPTION	KEY NO.	PART NO.	DESCRIPTION
1	-----	Transaxle Peerless LTH2000 (See Breakdown)	70	134683	Keeper Belt Engine
8	192502	Rod Shift Fender Adjust	74	137057	Spacer
10	STD561210	Pin Cotter 1/8 x 1 CAD	75	121749X	Washer 25/32 x 1-1/4 x 16 Ga.
14	10040400	Washer Lock Hvy Helical	76	STD581075	E-Ring
15	74490544	Bolt Hex FLGHD 5/16-18 Gr.5	77	123583X	Key, Square
16	STD541431	Nut Lock Hex W/Ins. 5/16-18 unc	78	121748X	Washer 25/32 x 1-5/8 x 16 Ga.
19	STD541437	Nut Lock Hex W/Wsh 3/8-16 unc	81	178139	Shaft Asm Cross Tapered
21	130564	Knob	82	165711	Spring Torsion
22	178141	Rod, Brake	83	19171216	Washer 17/32 x 3/4 x 16 Ga.
24	73350600	Nut, Hex Jam 3/8-16 unc	85	150360	Nut Lock Center 1/4-28 FNGTHD
25	106888X	Spring, Brake Rod	89	192387X428	Console, Shift
27	STD561210	Pin Cotter 1/8 x 3/4 CAD.	95	178134	Disconnect Asm Rod Bypas LTH
28	175765	Rod, Parking Brake	112	19091210	Washer 9/32 x 3/4 x 10 Ga.
29	71673	Cap, Parking Brake	116	72140608	Bolt Rdhd Sqneck 3/8-16 x 1
30	169592	Bracket, Transaxle	120	73900600	Nut Lock Flg 3/8-16
32	74760512	Bolt Hex Hd 5/16-18 unc x 3/4	150	175456	Spacer Retainer
34	175578	Shaft, Foot Pedal	151	19133210	Washer 13/32 x 2 x 10 Ga.
35	120183X	Bearing, Nylon	156	166002	Washer Srrted 5/16 ID x 1.125
36	19211616	Washer	158	165589	Bracket Shift Mount
37	1572H	Pin, Roll	159	183900	Hub Shift
38	179114	Pulley, Composite	161	72140406	Bolt Rdhd Sqnk 1/4-20 x 3/4 Gr. 5
39	72110622	Bolt Rdhd 3/8-16 unc x 2-3/4 Gr. 5	162	73680400	Nut Crownlock 1/4-20 unc
41	175556	Keeper, Belt Idler	163	74780416	Bolt Hex Fin 1/4-20 unc x 1 Gr. 5
47	127783	Pulley, Idler, V-Groove	165	165623	Bracket Pivot Lever
48	154407	Bellcrank, Clutch	166	17490510	Screw 5/16-18 x 5/8
49	123205X	Retainer, Belt	168	165492	Bolt Shoulder 5/16-18 x .561
50	72110612	Bolt Carr Sh 3/8-16 x 1-1/2 Gr 5	169	165580	Plate Fastening
51	STD541437	Nut Crownlock 3/8-16 unc	197	169613	Nyliner Snap-In 5/8"ID
52	STD541431	Nut, Crownlock 5/16-18 unc	198	169593	Washer Nyl 7/8 ID x .105" Hyd
53	105710X	Link, Clutch	202	72110614	Bolt Carr Sh 3/8-16 x 1-3/4 Gr.5
55	105709X	Spring, Return, Clutch	212	145212	Nut Hex Flange Lock
56	17060620	Screw 3/8-16 x 1-1/4	245	178122	Strap Torque Lh LTH2000
57	178138	V-Belt	246	178121	Strap Torque Rh LTH2000
59	169691	Keeper, Center Span	247	181462	Link Shift Transaxle LTH2000
61	17120614	Screw 3/8-16 x .875	250	17060612	Screw 3/8-16 x .75
62	8883R	Cover, Pedal	251	17060516	Screw 5/16-18 x 1
63	175410	Pulley, Engine	252	19131616	Washer 13/32 x 1 x 16 Ga.
64	173937	Bolt Hex 7/16-20 x 4 Gr. 5	263	17000612	Screw Hex Wsh Thdr 3/8-16 x 3/4
65	STD551143	Washer			
66	154778	Keeper Belt Engine Hydro			
69	142432	Screw Hex Wsh Hi-Lo 1/4-1/2 unc			

NOTE: All component dimensions given in U.S. inches
1 inch = 25.4 mm

TRACTOR - - MODEL NUMBER 917.274760 STEERING ASSEMBLY

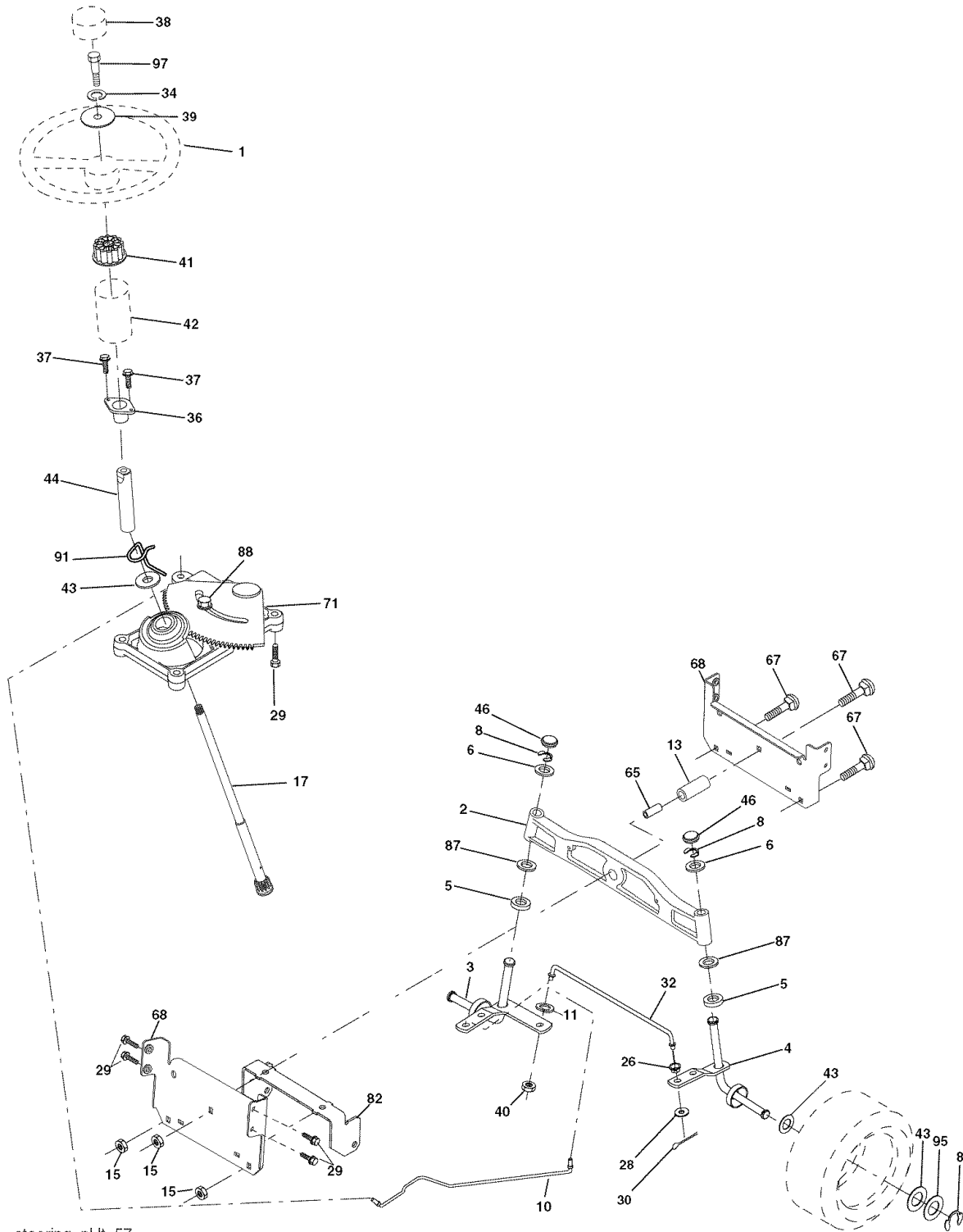

steering_pl.it_57

TRACTOR - - MODEL NUMBER 917.274760
STEERING ASSEMBLY

KEY NO.	PART NO.	DESCRIPTION
1	186780	Steering Wheel
2	184706	Axle Assembly Cast Iron
3	169840	Spindle Assembly, L.H.
4	169839	Spindle Assembly, R.H.
5	6266H	Bearing, Race, Thrust, Hardened
6	121748X	Washer 25/32 x 1-5/8 x 16 Ga.
8	12000029	Ring, Klip
10	175121	Draglink
11	STD551137	Washer, Lock
13	136518	Spacer Bearing Axle Front
15	145212	Nut, Hex Flange Lock
17	190753	Shaft, Steering
26	126847X	Bushing, Link, Drag
28	19131416	Washer 13/32 x 7/8 x 16 Ga.
29	17000612	Screw 3/8-16 x 3/4
30	STD561210	Pin Cotter
32	130465	Rod, Tie
34	10040500	Washer Split Hvy Hlcl Spr. 5/16
36	155099	Bushing, Steering
37	152927	Screw
38	186781	Insert, Steering Wheel
39	19183812	Washer 9/16 x 2-3/8 12 Ga.
40	73540600	Nut Crownlock 3/8-24
41	186737	Adaptor, Steering Wheel
42	145054X428	Boot, Steering Shaft
43	121749X	Washer 25/32 x 1-1/4 x 16 Ga.
44	190752	Extension Shaft Steering
46	184946X505	Cap, Spindle
65	160367	Spacer Brace Axle
67	72110618	Bolt RDHD Sqnk 3/8-16 x 2-1/4
68	169827	Axle, Brace
71	175146	Steering Asm.
82	169835	Bracket Susp. Chassis Front
87	173966	Washer Flat .781 x 1-1/2 x .14
88	175118	Bolt Shoulder 7/16-20 unc
91	175553	Clip Steering
95	188967	Washer Hardened
97	74780564	Bolt 5/16-18 unc x 4 Gr. 5

NOTE: All component dimensions given in U.S. inches
1 inch = 25.4 mm

TRACTOR - - MODEL NUMBER 917.274760

ENGINE

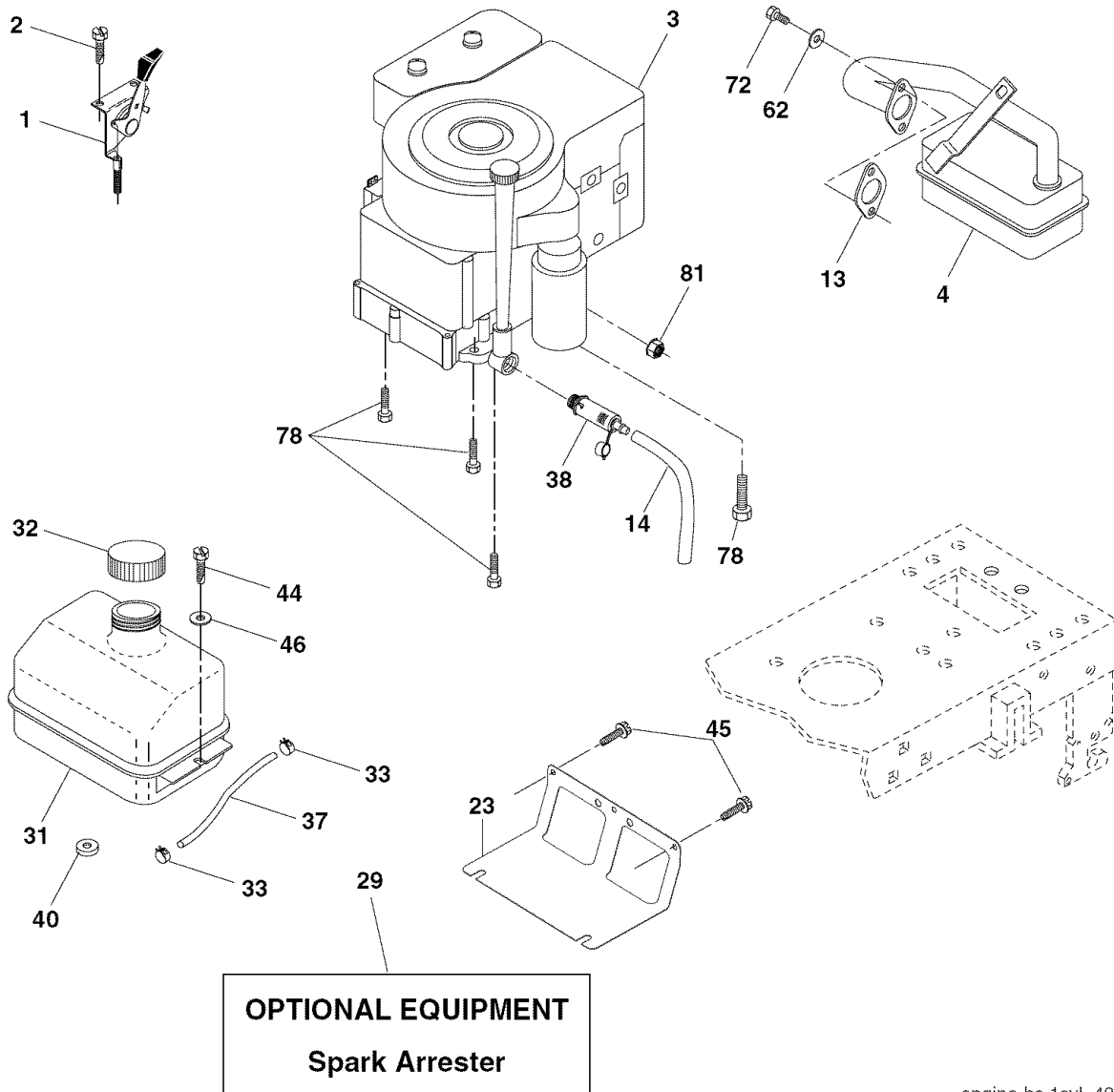

engine-bs.1cyl_49

KEY NO.	PART NO.	DESCRIPTION	KEY NO.	PART NO.	DESCRIPTION
1	170545X505	Control, Throttle/Choke	37	137040	Line, Fuel
2	17720408	Screw, Hex Head, Thread Cutting 1/4-20 x 1/2	38	181654	Plug Drain Oil Easy
3	-----	Engine, Briggs Model 31P777-0299-E1 (See Breakdown)	40	124028X	Bushing, Snap, Fuel Line
4	137352	Muffler	44	17670412	Screw, Hex Washer Head, Thd., Roll. 1/4-20 x 3/4
13	165291	Gasket	45	17000612	Screw Hxwsh Thdr 3/8-16 x 3/4
14	148456	Tube Drain Oil Easy	46	19091416	Washer 9/32 x 7/8 x 16 Ga.
23	169837	Shield Brn/Dbr Guard	62	10010500	Washer Split
29	137180	Arrestor, Spark	72	71070512	Screw Hex Head Cap 5/16-18 x 3/4
31	185115	Tank, Fuel	78	17060620	Screw 3/8-16 x 1-1/4
32	140527	Cap Assembly, Fuel Sears, Vented	81	73510400	Nut Keps Hex 1/4-20
33	123487X	Clamp, Hose			

NOTE: All component dimensions given in U.S. inches
1 inch = 25.4 mm

TRACTOR - - MODEL NUMBER 917.274760
SEAT ASSEMBLY

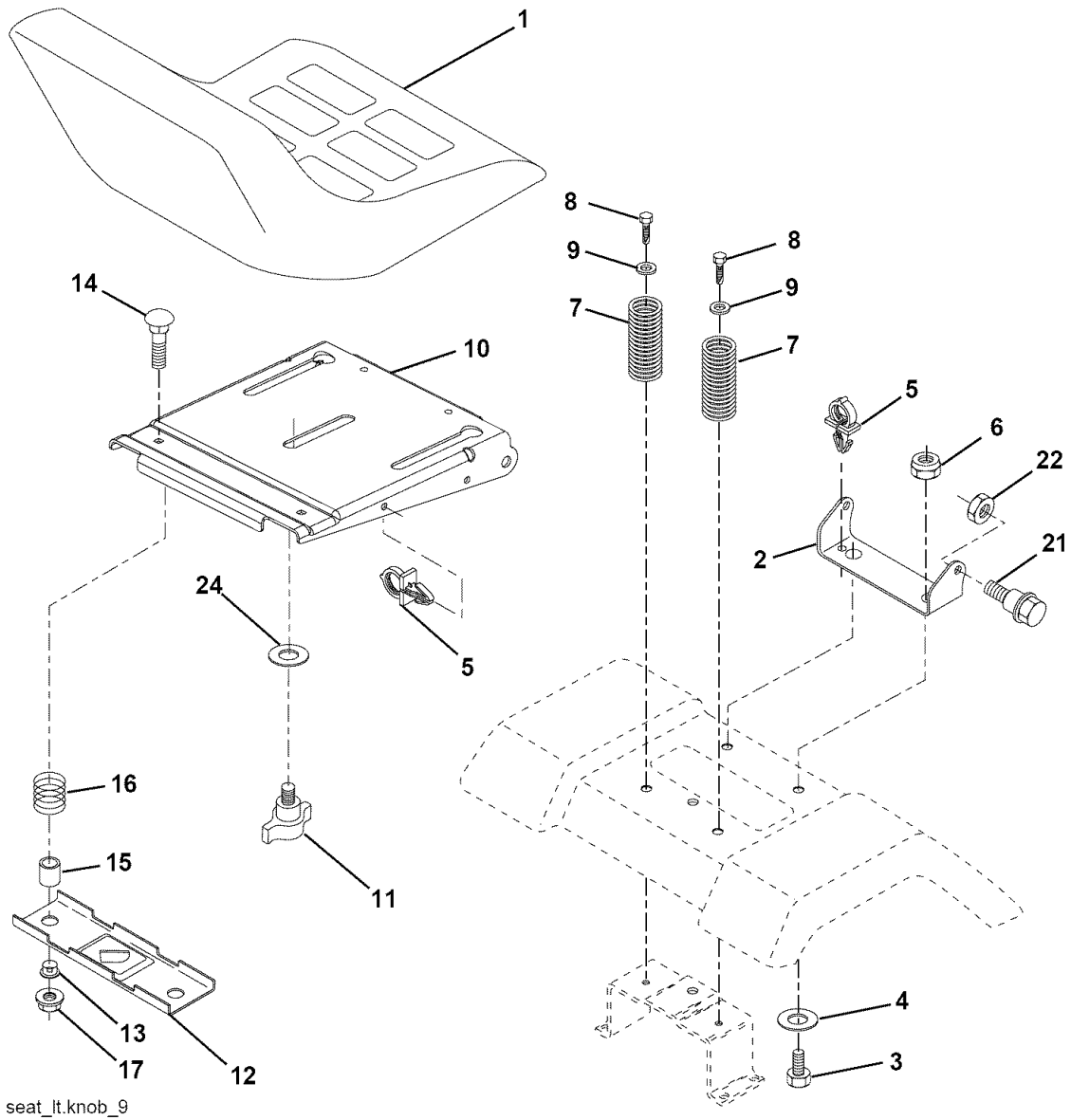

seat_lt.knob_9

KEY PART NO.	PART NO.	DESCRIPTION
1	188716	Seat
2	180166	Bracket Pnt Pivot Seat (blk)
3	71110616	Bolt Fin Hex 3/8-16 unc x 1
4	19131610	Washer 13/32 x 3/4 x 10 Ga.
5	145006	Clip Push In Hinged
6	STD541437	Nut Hex Lock w/Ins 3/8-16 unc
7	124181X	Spring Seat Cprsn 2 250 Blk Zi
8	17000616	Screw 3/8-16 x 1
9	19131614	Washer 13/32 x 1 x 14 Ga.
10	180186	Pan Pnt Seat (blk)
11	166369	Knob Seat Adj Wingnut

KEY PART NO.	PART NO.	DESCRIPTION
12	174648	Bracket Pnt Mounting Switch
13	121248X	Bushing Snap Blk Nyl 50 Id
14	72050412	Bolt Rdhd Sht Nk 1/4-20 x 1-1/2
15	134300	Spacer Split 28 x 96 Zinc
16	121250X	Spring Cprsn 1 27 Blk Pnt
17	123976X	Nut Lock 1/4 Lge Flg Gr. 5 Zinc
21	171852	Bolt Shoulder 5/16-18 unc-2A
22	STD541431	Nut Hex Lock w/Ins 5/16-18
24	19171912	Washer 17/32 x 1-3/16 x 12 Ga.

NOTE: All component dimensions given in U.S. inches
 1 inch = 25.4 mm

TRACTOR - - MODEL NUMBER 917.274760

DECALS

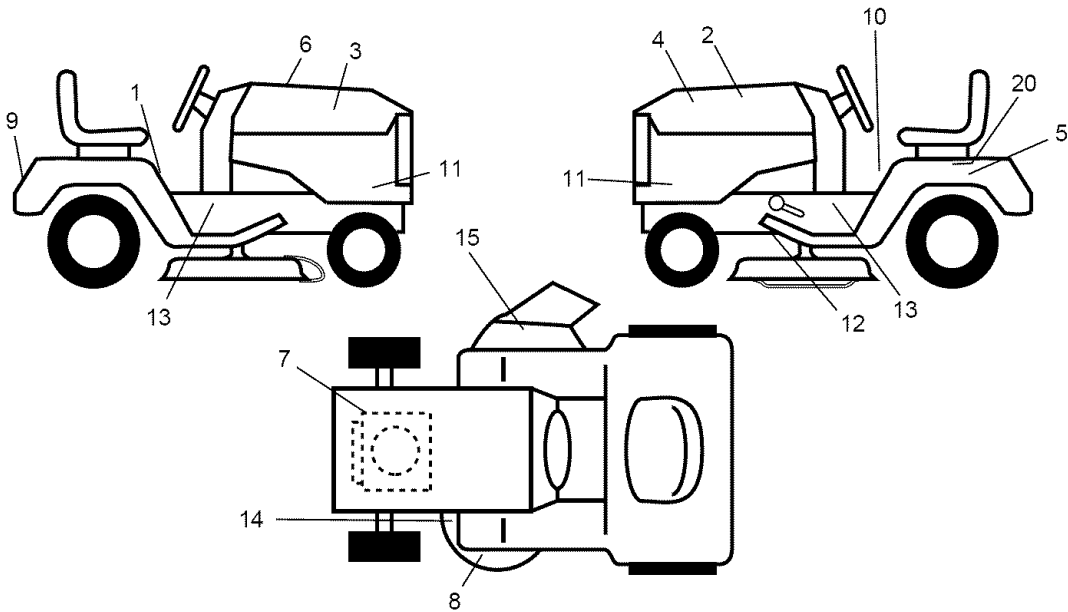

KEY PART NO. NO.

KEY PART NO.	NO.	DESCRIPTION
1	193307	Decal, Oper. Instr.
2	193563	Decal, Replacement
3	186280	Decal, Hood, R.H.
4	186281	Decal, Hood, L.H.
5	138047	Decal, Battery
6	133644	Decal, Customer Maintenance
7	191777	Decal, HP Engine
8	172331	Decal, Mower Srs
9	186282	Decal, Fender, Craftsman
10	156439	Decal, Fender Danger
11	186283	Decal, Panel Side
12	146046	Decal, V-Belt Drive Schematic
13	191551	Decal, Chassis

KEY PART NO. NO.

KEY PART NO.	NO.	DESCRIPTION
14	160396	Decal, V-Belt Schematic
15	179128	Decal, Deck B 42"
20	149516	Decal Battery Dngr/Psn Eng
--	138311	Decal, Lift Handle
--	178392	Decal, Chassis Disconnect
--	184310X428	Pad, Footrest LH STLT
--	184311X428	Pad, Footrest RH STLT
--	193299	Manual, Owner's, English
--	193300	Manual, Owner's, Spanish

WHEELS & TIRES

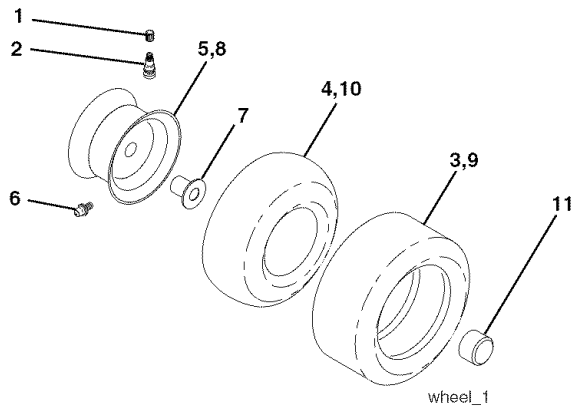

KEY PART NO. NO.

KEY PART NO.	NO.	DESCRIPTION
1	59192	Cap Value Tire
2	65139	Stem Valve
3	106222X	Tire F Ts 15 x 6.0 - 6 Service
4	59904	Tube Inner Front #35060
5	106732X624	Rim Asm 6" front White Service
6	278H	Fitting Grease
7	9040H	Bearing Flange
8	106108X624	Rim Asm 8" rear White Service
9	138468	Tire R Ts 20 x 8-8 Service
10	7152J	Tube Rear 9.5 x 8 Service
11	104757X428	Cap Axle Blk 1 50 x 1 00
--	144334	Sealant, Tire (10 oz. tube)

NOTE: All component dimensions given in U.S. inches
1 inch = 25.4 mm

TRACTOR - - MODEL NUMBER 917.274760

LIFT ASSEMBLY

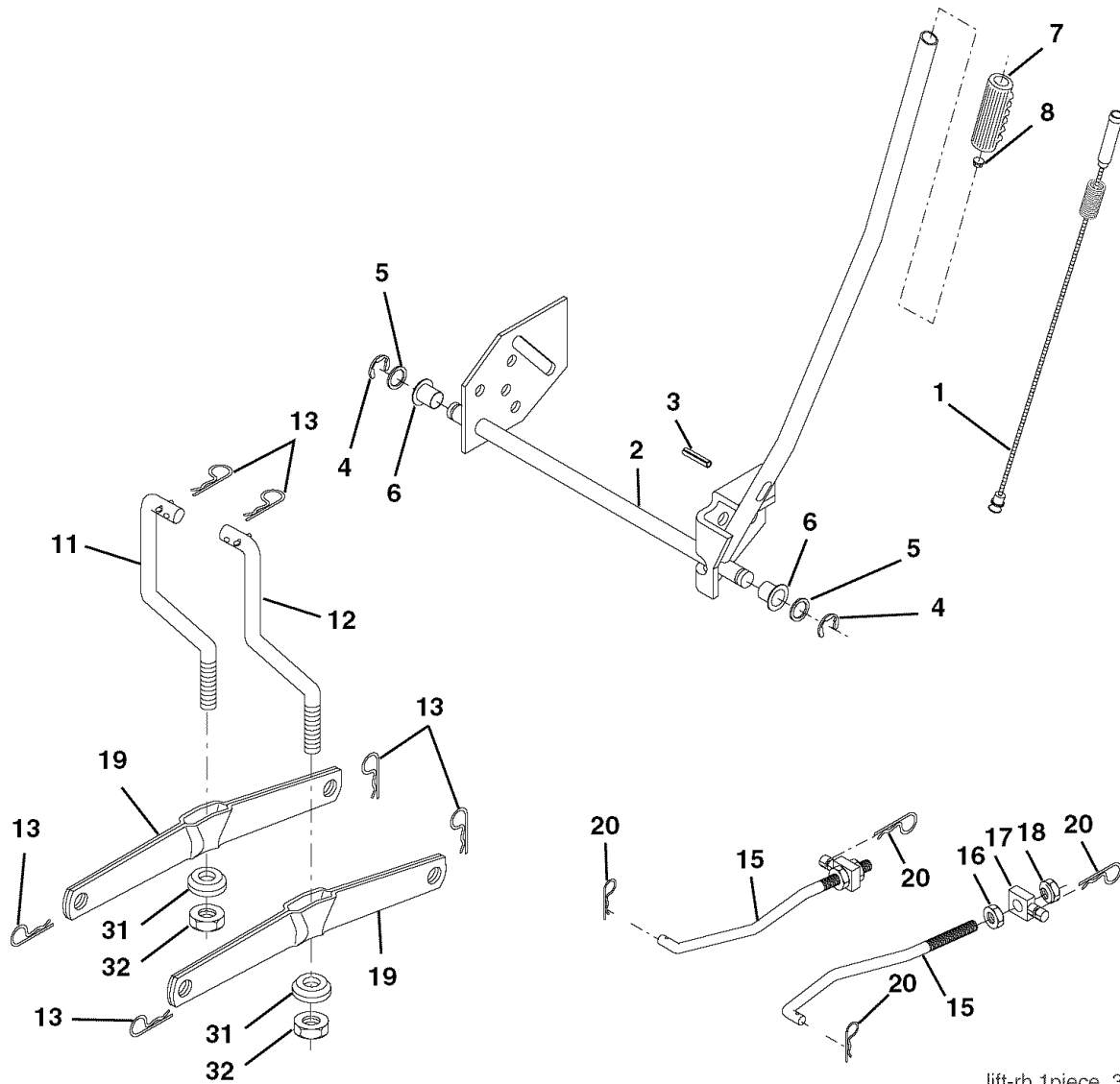

lift-rh.1piece_3

KEY NO.	PART NO.	DESCRIPTION
1	159460	Washer Asm Inner Spring W/ Plunger
2	159471	Shaft Asm. Lift
3	105767X	Pin Groove
4	12000002	E Ring #5133-62
5	19211621	Washer 21/32 x 1 x 21 Ga.
6	120183X	Bearing Nylon
7	125631X	Grip Handle Fluted
8	122365X	Button Plunger Read
11	139865	Link Asm Lift L.H.
12	139866	Link Asm Lift R.H.

KEY NO.	PART NO.	DESCRIPTION
13	STD624008	Retainer Spring
15	173288	Link Front
16	73350800	Nut Jam Hex 1/2-13 unc
17	175689	Trunnion Blk Zinc
18	73800800	Nut Lock w/Wsh 1/2-13 unc
19	139868	Arm Suspension Mower
20	163552	Retainer Spring
31	169865	Bearing, Pvt. Lift
32	73540600	Nut Crownlock 3/8-24

NOTE: All component dimensions given in U.S. inches
1 inch = 25.4 mm

TRACTOR - - MODEL NUMBER 917.274760

MOWER DECK

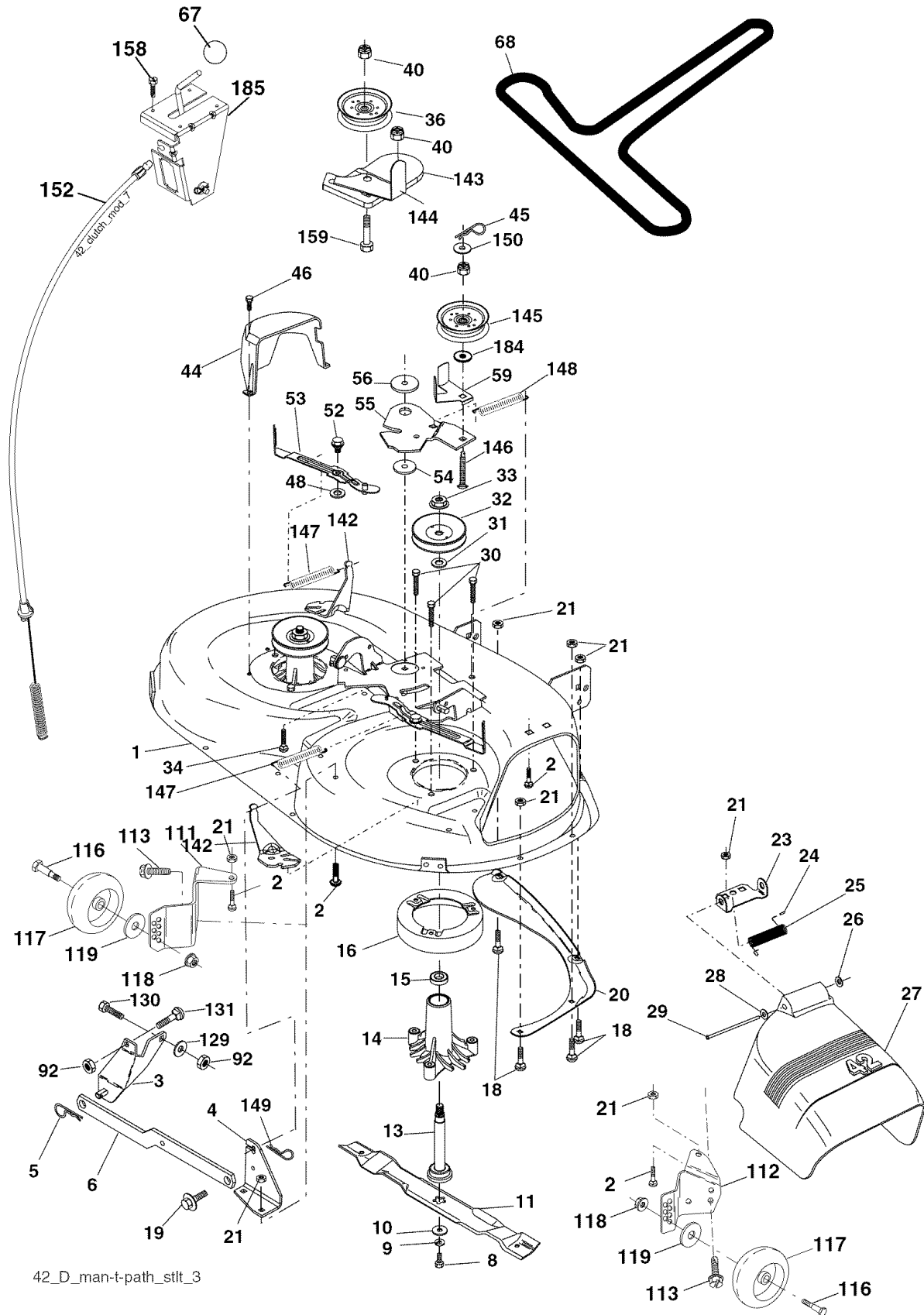

TRACTOR - - MODEL NUMBER 917.274760

MOWER DECK

KEY NO.	PART NO.	DESCRIPTION	KEY NO.	PART NO.	DESCRIPTION
1	165892	Mower Deck Assembly, 42"	48	133944	Washer, Hardened
2	STD533107	Bolt	52	139888	Bolt, Shoulder 5/16-18 unc
3	138017	Bracket Assembly, Sway Bar, Front	53	184907	Arm Assembly, Pad, Brake
4	165460	Bracket Sway Bar 38/42" Deck	54	178515	Washer, Hardened
5	STD624008	Retainer Spring	55	155046	Arm, Idler
6	178024	Bar Sway Deck	56	165723	Spacer, Retainer
8	850857	Bolt, Hex 3/8-24 x 1.25 Gr. 8	59	141043	Guard, TUV Idler
9	STD551137	Washer, Lock	67	184939	Knob Custom Oval
10	140296	Washer, Hardened	68	144959	V-Belt
		(The following blades are available)	92	STD541437	Nut
11	138971	Blade, 42" Hi-Lift	111	179292	Bracket Gauge Wheel Lh
--	134149	(For bagging or discharging)	112	179293	Bracket Gauge Wheel Rh
--	139775	Blade, 42" Mulching Std	113	17060510	Screw 5/16-18 unc
		(For mulching mowers only)	116	4898H	Bolt Shoulder
13	137645	Blade, 42" Mulching Premium	117	188606	Wheel Gauge
14	128774	(For better wear when mulching)	118	73930600	Nut Centerlock 3/8-16 unc
15	110485X	Shaft Assembly, Mandrel, Vented	119	19121414	Washer 3/8 x 7/8 x 4 Ga.
16	174493	Housing, Mandrel, Vented	129	19131312	Washer 13/32 x 13/16 x 12 Ga.
18	72140505	Bearing, Ball, Mandrel	130	STD523710	Bolt, Fin Hex 3/8-16 unc x 1 Gr. 5
19	132827	Stripper, Vented Mower Deck	131	STD533710	Bolt, Rdhd Sqnk 3/8-16 unc x 1
20	159770	Bolt, Carriage 5/16-18 x 5/8	142	165890	Arm Spring Brake Mower
21	STD541431	Bolt, Shoulder	143	157109	Bracket Arm Idler 42"
23	177563	Baffle, Vortex	144	158634	Keeper Belt 42" Clutch Cable
24	105304X	Nut Crownlock 5/16-18 unc	145	165888	Pulley Idler Flat
25	123713X	Bracket, Deflector	146	171977	Bolt Carriage Idler
26	110452X	Cap, Sleeve	147	131335	Spring Extension
27	130968X428	Spring, Torsion, Deflector	148	169022	Spring Return Idler
28	19111016	Nut, Push	149	165898	Retainer Spring Yellow Zinc
29	131491	Shield, Deflector	150	19091210	Washer 9/32 x 3/4 x 10 Ga.
30	173984	Washer 11/32 x 5/8 x 16 Ga.	152	169676	Cable Clutch 42 In
31	187690	Rod, Hinge	158	17720408	Screw Hex Thd Cut 1/4-20 x 1/2
32	153535	Screw Thdrol Washer Head	159	72140614	Bolt Rdhd Sqn 3/8-16 unc x 3/4
33	178342	Washer, Spacer	184	19131410	Washer 13/13 x 7/8 x 10 Ga.
34	STD533717	Pulley, Mandrel	185	188234	Head Asm Cable Clutch
36	131494	Nut, Toplock, Flanged	--	130794	Mandrel Assembly (Includes Housing, Shaft and Shaft Hardware Only - Pulley Not Included)
40	STD541437	Bolt	--	171491	Replacement Mower, Complete (Std. Deck-Order separately gauge wheel components key nos. 116 - 119).
44	140088	Pulley, Idler, Flat			
45	STD624003	Nut Crownlock 3/8-16 unc			
46	137729	Guard, Mandrel, L.H.			
		Retainer			
		Screw, Thd. Roll 1/4-20 x 5/8			

NOTE: All component dimensions given in U.S. inches
1 inch = 25.4 mm

TRACTOR - - MODEL NUMBER 917.274760
PEERLESS TRANSAXLE - - MODEL NUMBER LTH2000

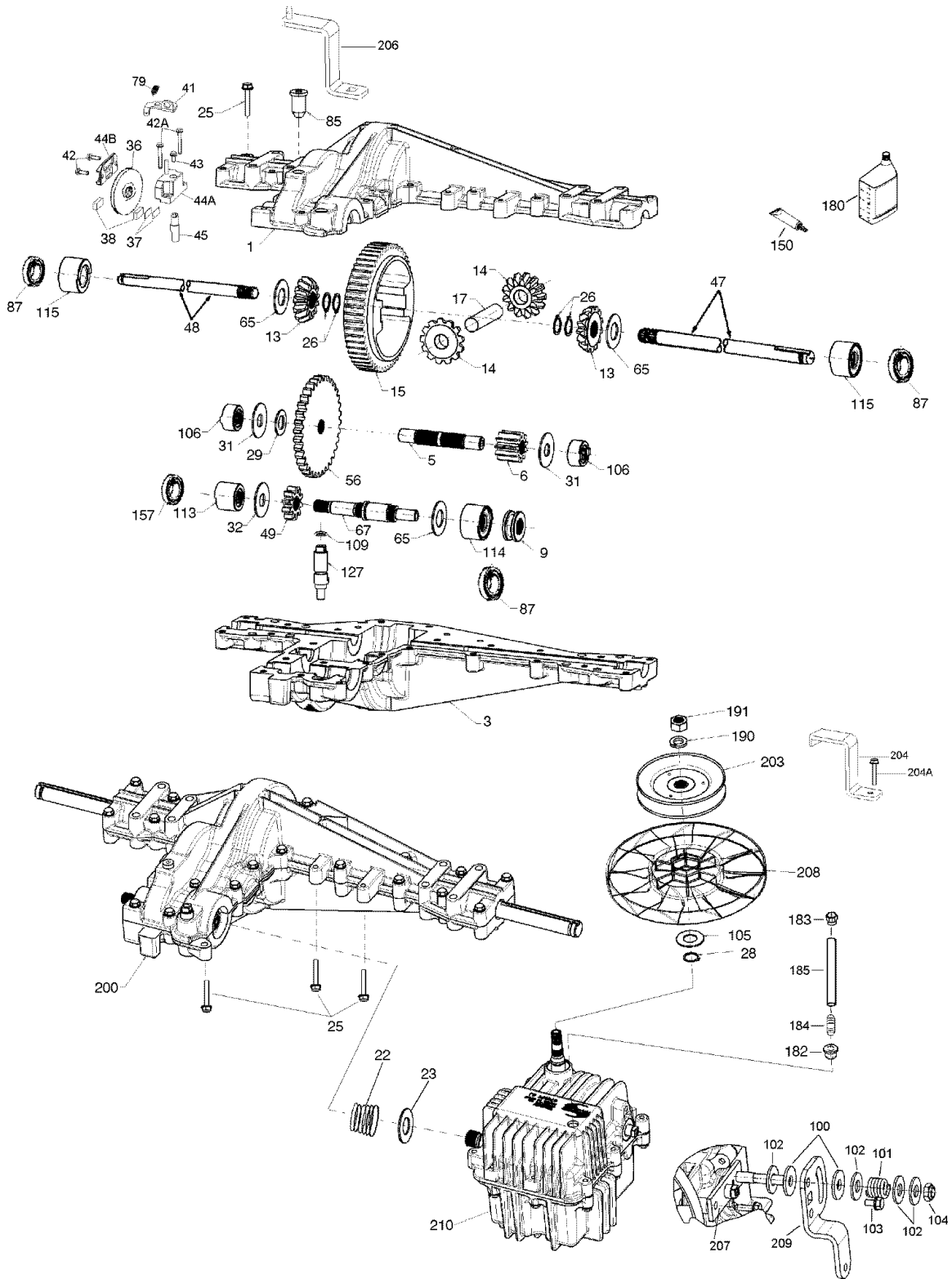

**TRACTOR - - MODEL NUMBER 917.274760
PEERLESS TRANSAXLE - - MODEL NUMBER LTH2000**

KEY NO.	PART NO.	DESCRIPTION	KEY NO.	PART NO.	DESCRIPTION
			70	786196	Spacer .625 .765
1	772151	Cover L.H.	79	792201	Spring
3	770135	Case	85	792154	Oil Fill Plug
5	776355	Counter Shaft	87	788088A	Oil Seal 3/4"
6	778263	Spur Gear 11T	99	792141	Washer .377ID .058W
9	786197	Neutral Sleeve (.572)	100	792200	Snubber Washer
13	778368	Bevel Gear (Incl. 14) (13 Teeth)	101	792199	Snubber Spring .47ID
14	778368	Bevel Gear (Incl. 13) (13 Teeth)	102	792184	Washer .437ID .078W
15	778373	Ring Gear (54 Teeth)	103	792193	Screw, 1/4-28 x .490
17	786139	Drive Pin	104	792198	Nut, 3/8-24
22	792194	Spring	105	780096	Washer .625 ID .057W
23	792195	Washer .750 ID	106	786162	Sleeve Assembly
25	792073A	Screw 1/4-20 x 1-1/4"	107	792046	Screw, 1/4-20 x 1"
26	792125	Retaining Ring	109	788104	"O" Ring
28	792035	Retaining Ring	113	786199	Sleeve Ass'y (Incl. 157)
29	780065	Washer .627 ID .091W	114	786200	Sleeve Ass'y (Incl. 87)
31	780189	Washer .563 ID .062W	115	786198	Sleeve Assembly (Incl. 87)
36	790071	Brake Disk	127	784384	Shift Lever Ass'y (Incl. 109)
37	790007	Brake Pad Plate	150	788093A	Liquid Gasket RTV Silicon
38	799021	Brake Pad	157	788102	Oil Seal 9/16"ID
40	792204	Roll Pin .25	180	730229	BOil Spec. (80W90)
41	790102	Brake Lever	182	788103	Grommet
42	792202	Screw, 1/4-20 x 3/4	183	792118	Relief Valve
42A	792203	Screw, 1/4-20 x 1-3/4	184	792196	Hose Barb
43	792171	Screw, 10-24 x .500	185	798050	Tubing 1/2 x 5
44A	790100	Inside Brake (Mach)	190	792150	Washer
44B	790099	Outside Brake (Casting)	191	792151	Nut 7/16-20
45	790101	Actuator Rod	200	794787	Differential (Gear Reduction Drive)
47	774869	Axle 16.812			
48	774688	Axle 11.625	203	798044	Pulley & Hub Ass'y
49	778378	Spur Gear 18T	206	798055	Disconnect Lever
56	778379	Spur Gear 81T	207	798053	Mounting Plate
65	780195	Washer .750ID .062W	208	798040	Fan
67	776440	Brakeshaft	209	798054	Control Lever
			210	794788	Hydro Module LH Fender Control

TRACTOR - - MODEL NUMBER 917.274760
BRIGGS & STRATTON ENGINE-MODEL NUMBER 31P777, TYPE NUMBER 0299-E1

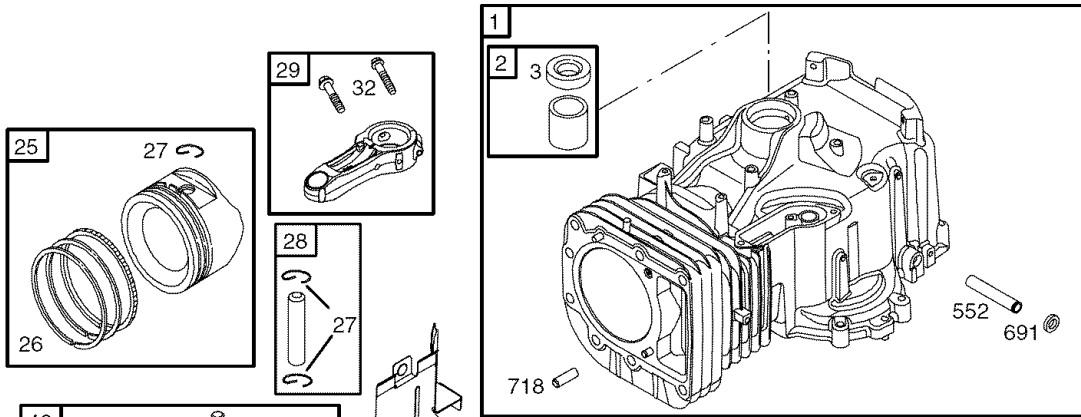

1330 REPAIR MANUAL

1329 REPLACEMENT ENGINE

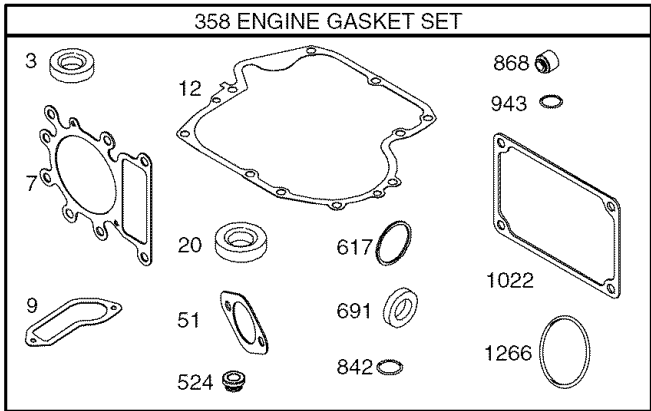

1019 LABEL KIT

1058 OWNER'S MANUAL

1036 EMISSION LABEL

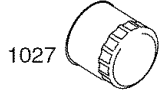
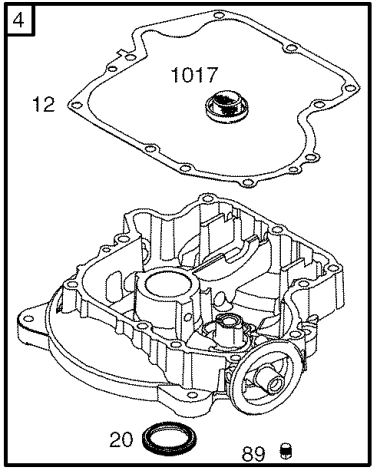
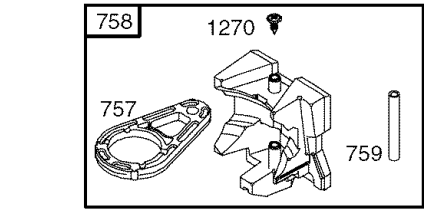
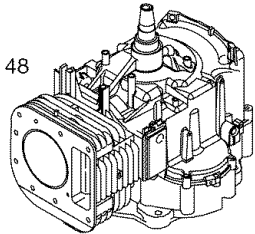
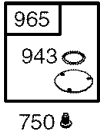

**TRACTOR - - MODEL NUMBER 917.274760
BRIGGS & STRATTON ENGINE-MODEL NUMBER 31P777, TYPE NUMBER 0299-E1**

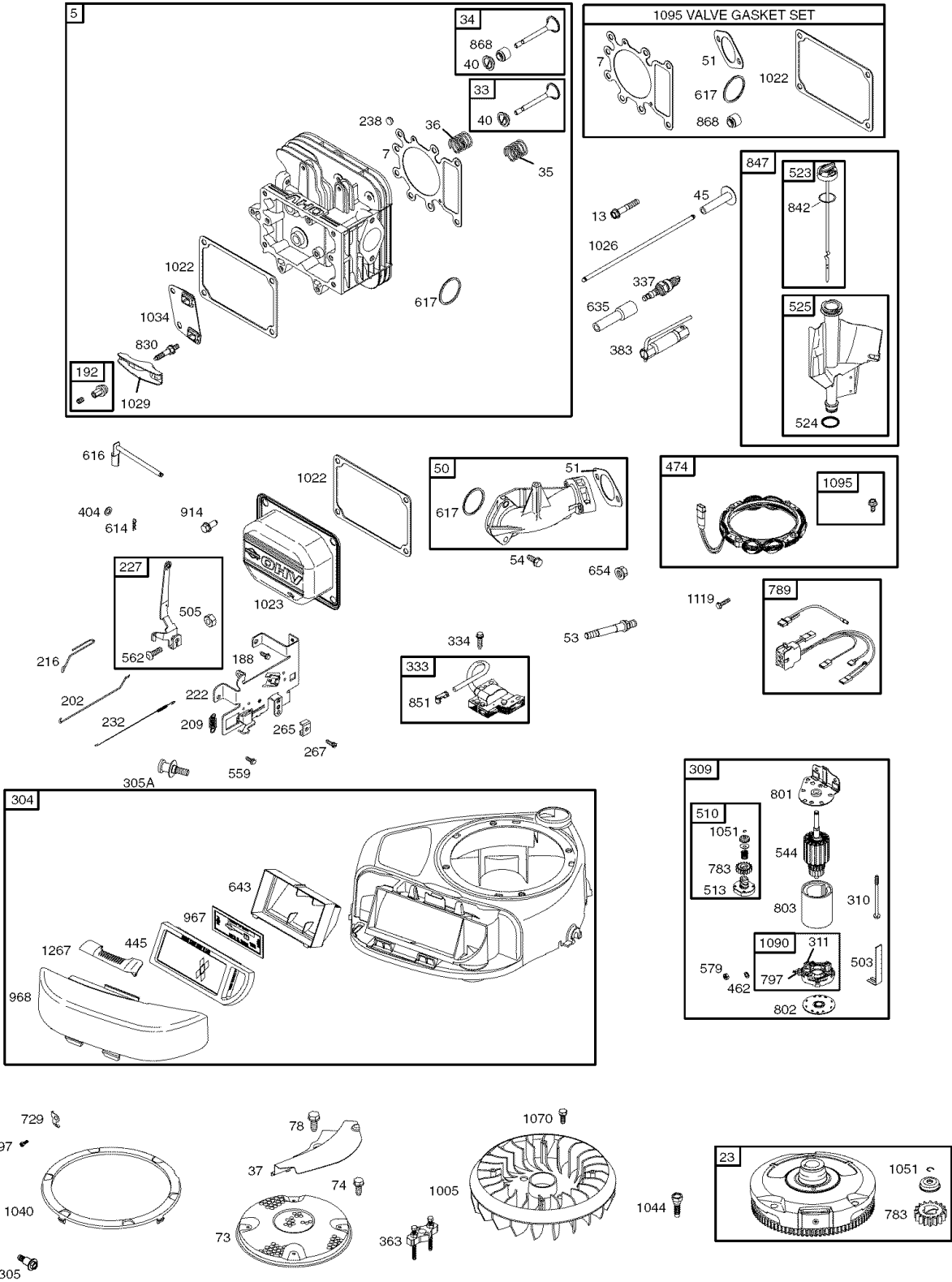

TRACTOR - - MODEL NUMBER 917.274760
BRIGGS & STRATTON ENGINE-MODEL NUMBER 31P777, TYPE NUMBER 0299-E1

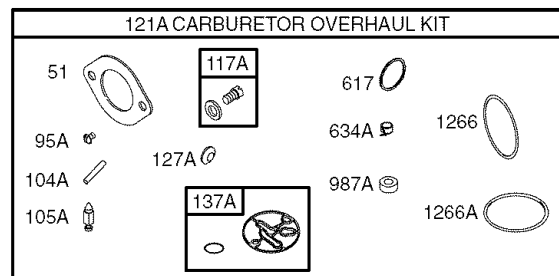
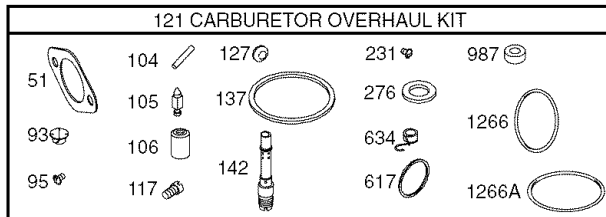
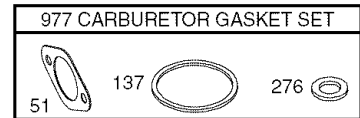
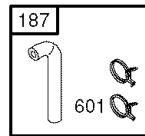
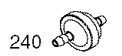
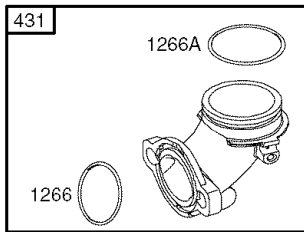
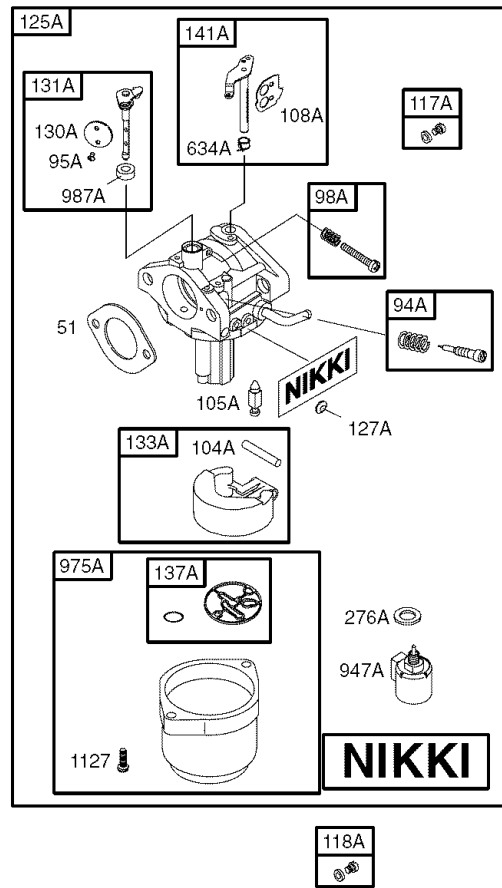
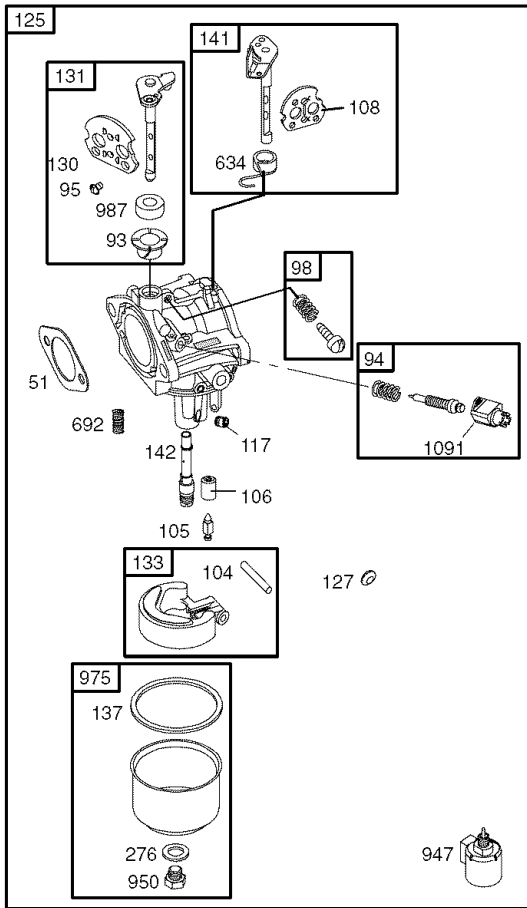

TRACTOR - - MODEL NUMBER 917.274760
BRIGGS & STRATTON ENGINE-MODEL NUMBER 31P777, TYPE NUMBER 0299-E1

KEY NO.	PART NO.	DESCRIPTION	KEY NO.	PART NO.	DESCRIPTION
1	697174	Cylinder Assembly	106	690577 Ø	Seat-Inlet
2	399265	Kit-Bushing/Seal (Magneto Side)	108	690464	Valve-Choke (Manual Choke)
3	391086 •	Seal-Oil (Magneto Side)	108A	695419	Valve-Choke (Nikki)
4	697188	Sump-Engine	117	694352 Ø	Jet-Main (Standard)
5	698147	Head-Cylinder	117A	699457 Ø	Jet-Main (Standard) (Nikki)
7	699168 •+	Gasket-Cylinder Head	118	697228	Jet-Main (High Altitude)
9	697109 •	Gasket-Breather	118A	699458	Jet-Main (High Altitude) (Nikki)
11	697113	Tube-Breather	121	697241	Kit-Carburetor Overhaul
12	697110 •	Gasket-Crankcase	121A	699521	Kit-Carburetor Overhaul (Nikki)
13	690360	Screw (Cylinder Head)	125	698445	Carburetor
15	690946	Plug-Oil Drain	125A	-- -- --	Carburetor (For Complete
16	697127	Crankshaft			Carburetor,
20	690947 •	Seal-Oil (PTO Side)			Service with 698445)
22	692125	Screw (Crankcase Cover/Sump)	127	695005	Plug-Welch
23	693557	Flywheel	127A	690727 Ø	Plug-Welch (Nikki)
24	222698	Key-Flywheel	130	691750	Valve-Throttle
25	699052	Piston Assembly (Standard)	130A	699500	Valve-Throttle (Nikki)
--	699054	Piston Assembly (.020" Oversize)	131	494379	Kit-Throttle Shaft
26	699051	Ring Set (Standard)	131A	699501	Kit-Throttle Shaft (Nikki)
--	697559	Ring Set (.020" Oversize)	133	494381	Float-Carburetor
27	698469	Lock-Piston Pin	133A	694914	Float-Carburetor (Nikki)
28	697099	Pin-Piston	135	698780	Tube-Fuel Transfer
29	697126	Rod-Connecting (Standard)	137	281165 Ø‡	Gasket-Float Bowl
--	697263	Rod-Connecting (.020" Undersize)	137A	698781 Ø	Gasket-Float Bowl (Nikki)
32	692852	Screw (Connecting Rod)	141	495097	Kit-Choke Shaft (Manual Choke)
33	695760	Valve-Exhaust	141A	698778	Kit-Choke Shaft (Nikki)
34	695761	Valve-Intake	142	697140 Ø	Nozzle-Carburetor
35	691279	Spring-Valve (Intake)	146	691639	Key-Timing
36	691279	Spring-Valve (Exhaust)	187	699331	Line-Fuel
37	697352	Guard-Flywheel	188	691693	Screw (Control Bracket)
40	690964	Retainer-Valve	192	691986	Adjuster-Rocker Arm
43	691968	Slinger-Governor/Oil	202	691841	Link-Mechanical Governor
45	690564	Tappet-Valve	209	692208	Spring-Governor
46	698492	Camshaft	216	691840	Link-Choke
48	697762	Short Block	222	694042	Bracket-Control
50	690193	Manifold-Intake	227	691374	Lever-Governor Control
51	692137 •Ø‡+	Gasket-Intake	232	691842	Spring-Governor
53	690227	Stud (Carburetor)	238	691843	Cap-Valve
54	691148	Screw (Intake Manifold)	240	394358	Filter-Fuel
73	697133	Screen-Rotating	265	691024	Clamp-Casing
74	697897	Screw (Rotating Screen)	267	695134	Screw (Casing Clamp)
78	691003	Screw (Flywheel Guard)	276	692255 Ø‡	Washer-Sealing
89	690283	Plug-Oil	276A	695410	Washer-Sealing
93	690602 Ø	Bushing-Throttle Shaft	304	699828	Housing-Blower
94	498030	Kit-Idle Mixture	305	697102	Screw (Blower Housing)
94A	695425	Kit-Idle Mixture (Nikki)	305A	697103	Screw (Blower Housing)
95	691636	Screw (Throttle Valve)	306	697107	Shield-Cylinder
95A	690718 Ø	Screw (Throttle Valve (Nikki)	307	691003	Screw (Cylinder Shield)
98	495800	Kit-Idle Speed	309	693551	Motor-Starter
98A	695408	Kit-Idle Speed (Nikki)			
104	690525 Ø	Pin-Float Hinge	•		Included in Engine Gasket Set, Key. No. 358
104A	694918 Ø	Pin-Float Hinge (Nikki)	Ø		Included in Carburetor Overhaul Kit, Key. No. 121
105	231855 Ø	Valve-Float Needle	‡		Included in Carburetor Gasket Set, Key. No. 977
105A	696136 Ø	Valve-Float Needle (Nikki)	+		Included in Valve Gasket Set, Key. No. 1095

NOTE: All component dimensions given in U.S. inches
1 inch = 25.4 mm

TRACTOR - - MODEL NUMBER 917.274760
BRIGGS & STRATTON ENGINE-MODEL NUMBER 31P777, TYPE NUMBER 0299-E1

KEY NO.	PART NO.	DESCRIPTION	KEY NO.	PART NO.	DESCRIPTION
310	690323	Bolt (Starter Motor)	851	692424	Terminal-Spark Plug
311	497608	Brush Set	868	690968	•• Seal-Valve
333	495859	Armature-Magneto	914	691108	Screw (Rocker Cover)
334	691061	Screw (Magneto Armature)	943	690589	• Seal-O Ring (Oil Pump Cover)
337	691043	Plug-Spark	947	694393	Solenoid-Fuel
358	697191	Gasket Set-Engine	947A	695423	Solenoid-Fuel (Nikki)
363	19203	Flywheel Puller	950	691657	Screw (Float Bowl)
383	89838	Wrench-Spark Plug	965	499613	Cover-Oil Pump
404	691691	Washer (Governor Crank)	967	697015	Filter-Pre Cleaner
431	697122	Elbow-Intake	968	699848	Cover-Air Cleaner
445	698083	Filter-Air Cleaner Cartridge	975	495933	Bowl-Float
462	691261	Washer (Starter Cable)	975A	699502	Bowl-Float (Nikki)
474	696459	Alternator	977	690192	Gasket Set-Carburetor
503	691532	Strap-Starter	987	691326	∅ Seal-Throttle Shaft
505	691251	Nut (Governor Control Lever)	987A	698777	∅ Seal-Throttle Shaft (Nikki)
510	693699	Drive-Starter	1005	699043	Fan-Flywheel
513	692024	Clutch-Drive	1017	690770	Screen-Oil Pump
523	697086	Dipstick	1019	698814	Kit-Label
524	691032	• Seal-Dipstick Tube	1022	272475	•• Gasket-Rocker Cover
525	697184	Tube-Dipstick	1023	692492	Cover-Rocker Arm
527	698467	Clamp-Tube	1024	499054	Pump-Oil
544	692034	Starter-Armature	1026	692003	Rod-Push (Intake)
552	697144	Bushing-Governor Crank	-- --	692011	Rod-Push (Exhaust)
559	693675	Screw (Remote Choke Stop)	1027	492932	Filter-Oil
562	691119	Bolt (Governor Control Lever)	1029	691751	Arm-Rocker
579	691029	Nut (Starter Cable)	1034	690822	Guide-Push Rod
584	697112	Cover-Breather Passage	1035	693784	Shaft-Pump
601	95162	Clamp-Hose	1036	695700	Label-Emission
614	691620	Pin-Cotter	1040	699852	Plate-Trim
616	692012	Crank-Governor	1044	698139	Screw (Flywheel)
617	692138	∅ • Seal-O Ring (Intake Manifold)	1051	691265	Ring-Retaining
634	690801	∅ Spring/Seal Assembly (Manual Choke)	1058	275038	Owner's Manual
634A	698779	∅ Spring/Seal Assembly (Nikki)	1059	698516	Kit-Screw/Washer
635	691909	Boot-Spark Plug	1070	690372	Screw (Flywheel Fan)
643	698401	Retainer-Air Filter	1090	691293	Retainer-Brush
654	690958	Nut (Carburetor)	1091	691333	Cap-Limiter
684	697157	Screw (Breather Passage Cover)	1095	690190	Gasket Set-Valve
691	692407	• Seal-Governor Shaft	1119	691183	Screw (Alternator)
692	690572	Spring-Detent	1127	695407	Screw-Float Bowl
697	690372	Screw (Drive Cap)	1263	697124	Reed-Breather
718	690959	Pin-Locating	1264	697104	Screw (Breather Reed)
729	691224	Clip-Wire	1266	691917	•∅ Seal-O Ring (Intake Elbow)
741	697128	Gear-Timing	1266A	697123	∅ Seal-O Ring (Intake Elbow)
750	691033	Screw (Oil Pump Cover)	1267	697424	Latch-Blower Housing
757	697607	Link-Counterweight	1270	697156	Plug-AVS Counterweight
758	697134	Counterweight	1329	31Q777-0036	Replacement Engine
759	697392	Pin-Counterweight	1330	272147	Repair Manual
783	693713	Gear-Pinion	•		Included in Engine Gasket Set, Key. No. 358
789	698329	Harness-Wiring	∅		Included in Carburetor Overhaul Kit, Key. No. 121
797	693167	Nut (Brush Retainer)	‡		Included in Carburetor Gasket Set, Key. No. 977
801	691283	Cap-Drive	+		Included in Valve Gasket Set, Key. No. 1095
802	691286	Cap-End			
803	693757	Housing-Starter			
830	691095	Stud (Rocker Arm)			
842	691031	• Seal-O Ring (Dipstick Tube)			
847	697611	Dipstick/Tube Assembly			

NOTE: All component dimensions given in U.S. inches

1 inch = 25.4 mm

SUGGESTED GUIDE FOR SIGHTING SLOPES FOR SAFE OPERATION

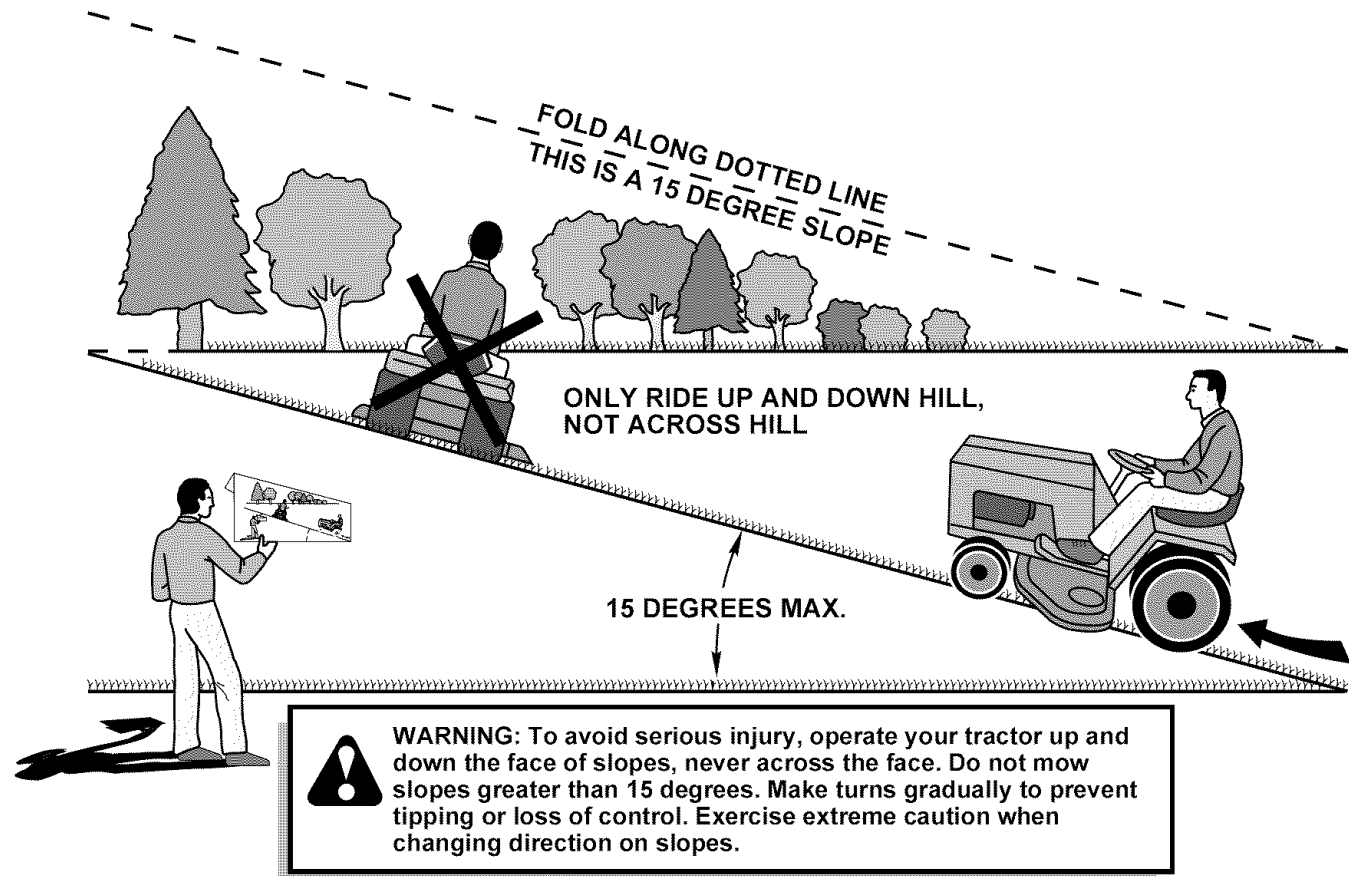

WARNING: To avoid serious injury, operate your tractor up and down the face of slopes, never across the face. Do not mow slopes greater than 15 degrees. Make turns gradually to prevent tipping or loss of control. Exercise extreme caution when changing direction on slopes.

1. Fold this page along dotted line indicated above.
2. Hold page before you so that its left edge is vertically parallel to a tree trunk or other upright structure.
3. Sight across the fold in the direction of hill slope you want to measure.
4. Compare the angle of the fold with the slope of the hill.

Get it fixed, at your home or ours!

Your Home

For repair – **in your home** – of **all** major brand appliances, lawn and garden equipment, or heating and cooling systems, **no matter who made it, no matter who sold it!**

For the replacement parts, accessories and owner's manuals that you need to do-it-yourself.

For Sears professional installation of home appliances and items like garage door openers and water heaters.

1-800-4-MY-HOME[®] Anytime, day or night
(1-800-469-4663) (U.S.A. and Canada)
www.sears.com www.sears.ca

Our Home

For repair of carry-in products like vacuums, lawn equipment, and electronics, call or go on-line for the nearest **Sears Parts and Repair Center.**

1-800-488-1222 Anytime, day or night (U.S.A. only)
www.sears.com

To purchase a protection agreement (U.S.A.)
or maintenance agreement (Canada) on a product serviced by Sears:

1-800-827-6655 (U.S.A.) **1-800-361-6665** (Canada)

Para pedir servicio de reparación
a domicilio, y para ordenar piezas:

1-888-SU-HOGARSM
(1-888-784-6427)

Au Canada pour service en français:

1-800-LE-FOYER^{MC}
(1-800-533-6937)
www.sears.ca

SEARS

02410

© Sears, Roebuck and Co.

® Registered Trademark / TM Trademark / SM Service Mark of Sears, Roebuck and Co.

® Marca Registrada / TM Marca de Fábrica / SM Marca de Servicio de Sears, Roebuck and Co.

^{MC} Marque de commerce / ^{MD} Marque déposée de Sears, Roebuck and Co.