

User's Information Manual



PY1P-B / PY2P-B Single-Packaged Gas Heat/Electric Cooling Unit

NOTE: Read the entire instruction manual before starting the installation.

SAFETY CONSIDERATIONS

Note to Installer: This manual should be left with the equipment user.

⚠ WARNING: Do not store or use gasoline or other flammable vapors and liquids in the vicinity of this or any other appliance. Failure to follow this warning could result in fire, serious injury, or death.

⚠ WARNING: Do not use this unit if any part has been under water. Immediately call a qualified service technician to inspect the unit and to replace any part of the control system which has been under water. Failure to follow this warning could result in electrical shock, fire, serious injury, or death.

⚠ WARNING: For your safety if you smell gas

1. Do not try to light any appliance.
 2. Do not touch any electrical switch; do not use any phone in your building.
 3. Immediately call your gas supplier from a nearby phone. Follow the gas supplier's instructions.
 4. If you cannot reach your gas supplier, call the fire department.
-

⚠ WARNING: Before performing recommended maintenance, be sure the main power switch to unit is turned off and lock-out tag installed. Electric shock could cause serious injury or death.

UNIT INTRODUCTION

This PY1P-B / PY2P-B unit is a small packaged gas heat/electric cooling system that can provide year-round comfort.

Starting or Shutting Unit Off

NOTE: Your combination heating/cooling unit is equipped with an automatic direct spark ignition and power combustion blower.

⚠ WARNING: Do not attempt to light by hand; serious injury may result.

TO LIGHT UNIT:

⚠ DANGER:

1. Do not turn off the electrical power to unit without first turning off the gas supply.
2. Before attempting to start the gas heating section, familiarize yourself with all the procedures that must be followed.

If you do not follow these instructions exactly, a fire or explosion may result, causing property damage, injury, or loss of life.

Refer to Fig. 1 or Fig. 2 for location of unit access panel and gas valve. Refer to Fig. 3 while proceeding with the following steps.

1. Set the temperature selector on room thermostat to the lowest temperature setting and set system switch to HEAT.
2. Close the external manual gas shutoff valve.
3. Turn off the electrical supply to the unit.
4. Remove the front access panel with a 5/16-in. nut driver.
5. Move the selector switch on the internal gas valve to the OFF position and wait 5 minutes.

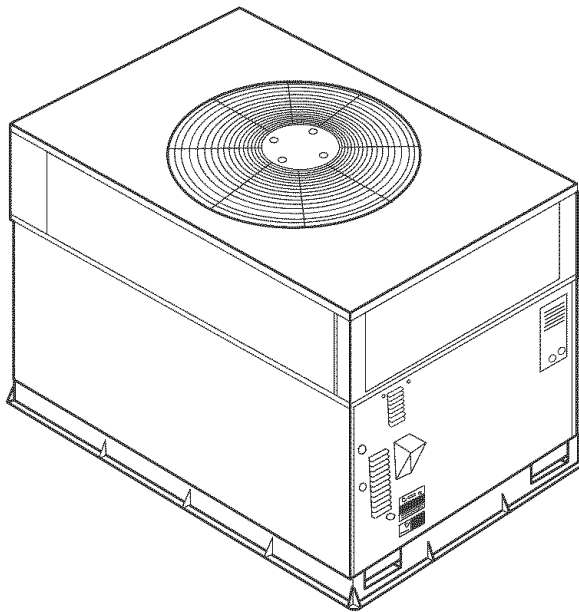

C99088

Fig. 1—Unit PY1P-B / PY2P-B

6. Move the selector switch on the internal gas valve to the ON position.
7. Replace the front access panel.
8. Turn on the electrical supply to unit.
9. Open the external manual gas shutoff valve.
10. Set the temperature selector on room thermostat slightly above room temperature to start unit. The induced-draft combustion air fan will start. Main gas valve will open and main burners should ignite within 5 seconds. If the burner does not light within 5 seconds, the ignition module will go into a Retry mode after a period of approximately 22 seconds (following the 5-second ignition period). If the burners do not light within 15 minutes of the initial call for heat, there is a lockout.
11. Set the temperature selector on room thermostat to desired setting.

⚠ WARNING:

1. If the main burners fail to light, or the blower fails to start, shut down gas heating section and call your dealer for service.
2. Never attempt to manually light the main burners on unit with a match, lighter, or any other flame. If the electric sparking device fails to light the main burners, refer to the following shutdown procedures, then call your dealer as soon as possible.

Failure to follow these requirements could result in serious injury or death.

TO SHUT UNIT OFF

⚠ WARNING: Do not turn off the electrical power to unit without first turning off the gas supply. Failure to follow these procedures can result in serious fire or personal injury.

NOTE: If unit is being shut down because the heating season has ended, make sure to turn on power to cooling system.

If unit is being shut down because of a malfunction, call your dealer as soon as possible.

Should overheating occur or the gas supply fail to shut off, shut off the manual gas valve to the unit before shutting off the electrical supply. Do not use this unit if any part has been under water. Immediately call a qualified service technician to inspect the unit and to replace any part of the control system and any gas control which has been under water.

Refer to Fig. 4 while proceeding with the following steps.

1. Set the temperature selector on room thermostat to lowest temperature setting and set system switch to OFF.
2. Close the external manual shutoff valve.
3. Turn off the electrical power supply to the unit.
4. Remove the front access panel.
5. Move the selector switch on the internal gas valve to the OFF position.
6. Replace the front access panel.
7. Restore electrical power to the unit and set system switch to COOL to ensure operation of the cooling system during the cooling season.

OPERATING YOUR UNIT

The operation of your system is controlled by the indoor temperature control (Thermostat). You simply adjust the thermostat and it maintains the indoor temperature at the level you select. Most thermostats of heating and cooling systems have 3 controls: a temperature control selector, a FAN control, and a SYSTEM or MODE control. Refer to your thermostat owner's manual for more information.

Table 1—Indoor-Air Filter Data

UNIT SIZE	FILTER SIZE
PY1P-B 018-030	20 x 20
PY1P-B 036-042	20 x 24
PY1P-B 048-060	24 x 30

To better protect your investment and to eliminate unnecessary service calls, familiarize yourself with the following facts:

PROCEDURE 1—COOLING MODE

With the SYSTEM or MODE control set to COOL, your unit will run in cooling mode until the indoor temperature is lowered to the level you have selected. On extremely hot days, your unit will run for longer periods at a time and have shorter “off” periods than on moderate days.

PROCEDURE 2—GAS HEAT MODE

With the SYSTEM or MODE control of your indoor thermostat set to HEAT, your unit will run in gas heating mode. On cold days and nights, your system will typically run for longer periods of time.

MAINTENANCE AND SERVICE

This section discusses maintenance that should be performed on your system. Most maintenance should be performed by your dealer. You, as the owner, may wish to handle some minor maintenance for your new unit.

A. Routine Maintenance

All routine maintenance should be handled by skilled, experienced personnel. Your dealer can help you establish a standard procedure.

For your safety, keep the unit area clear and free of combustible materials, gasoline, and other flammable liquids and vapors.

To assure proper functioning of the unit, flow of condenser air must not be obstructed from reaching the unit. Clearance from the top of the unit is 48 in. Clearance of at least 36 in. is required on sides except the power entry side (42 in. clearance) and the duct side (12 in. minimum clearance).

B. Maintenance and Care for the Equipment Owner

Before proceeding with those things you might want to maintain yourself, please carefully consider the following:

-
- ⚠ WARNING: 1. TURN OFF ALL ELECTRICAL POWER TO YOUR UNIT AND INSTALL LOCK-OUT TAG BEFORE SERVICING OR PERFORMING MAINTENANCE. ELECTRIC SHOCK COULD CAUSE SERIOUS INJURY OR DEATH.**
 - 2. When removing access panels or performing maintenance functions inside your unit, be aware of sharp sheet metal parts and screws. Although special care is taken to keep sharp edges to a minimum, be extremely careful when handling parts or reaching into the unit.**
-

AIR FILTERS

The air filter(s) should be checked at least every 3 or 4 weeks and changed or cleaned whenever it becomes dirty. Dirty filters produce excessive stress on the blower motor and can cause the motor to overheat and shut down. Table 1 indicates the correct filter size for your unit. Refer to Fig. 2 to access the filters.

To replace or inspect filters (or accessory filter rack when supplied):

1. Remove the filter access panel using a 5/16-in. nut driver.
2. Remove the filter(s) by pulling it out of the unit. If the filter(s) is dirty, clean or replace with a new one.

When installing the new filter(s), note the direction of the airflow arrows on the filter frame.

If you have difficulty locating your air filter(s) or have questions concerning proper filter maintenance, contact your dealer for instructions. When replacing filters, always use the same size and type of filter that was supplied, originally, by the installer.

-
- ⚠ CAUTION: Never operate your unit without the filter(s) in place. Failure to heed this warning may result in damage to the blower motor and/or compressor. An accumulation of dust and lint on internal parts of your unit can cause loss of efficiency and , in some cases, a fire.**
-

FANS AND FAN MOTORS

Periodically, check the condition of fan wheels and housings and fan-motor shaft bearings. Contact your dealer for the required annual maintenance.

HEAT EXCHANGER

To ensure dependable and efficient heating operation, the heat exchanger should be checked by a qualified maintenance person before each heating season, and cleaned when necessary. This checkout should not be attempted by anyone not having the required expertise and equipment to properly do the job. Contact your dealer for the required periodic maintenance.

EVAPORATOR AND CONDENSER COILS

Cleaning of the coils should only be done by qualified service personnel. Contact your dealer for the required annual maintenance.

CONDENSATE DRAIN

The condensate drain and condensate drain line should be checked and cleaned at the same time the cooling coils are checked by your dealer.

UNIT SIZE	FILTER SIZE
PY2P-B 024-030	20 x 20
PY2P-B 036	20 x 24
PY2P-B 042-060	24 x 30

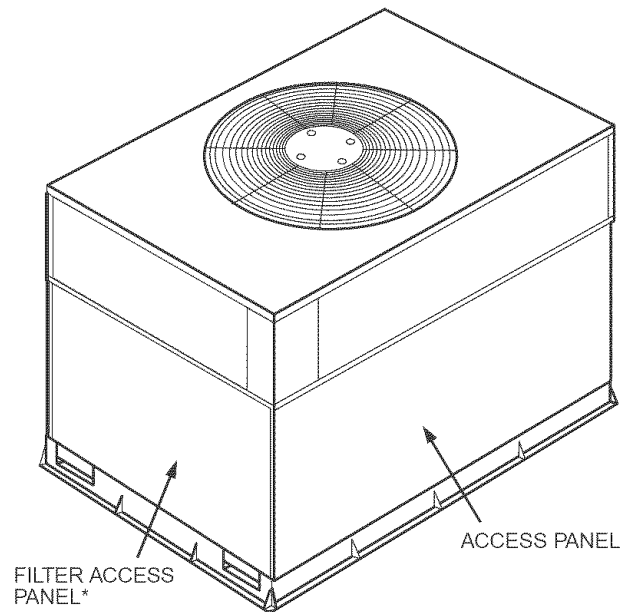

*For accessory filter rack.

C99094

Fig. 2—Filter Access Panel-Vertical Supply Shown

COMPRESSOR

All compressors are factory-shipped with a normal charge of the correct type refrigeration grade oil. A compressor should rarely require additional oil.

CONDENSER (OUTDOOR) FAN

⚠ CAUTION: Do not poke sticks, screwdrivers, or any other objects into revolving fan blades. Injury or equipment damage may result.

The fan must be kept free of all obstructions to ensure proper cooling. Contact your dealer for any required service.

ELECTRICAL CONTROLS AND WIRING

Electrical controls are difficult to check without proper instrumentations. If there are any discrepancies in the operating cycle, contact your dealer and request service.

REFRIGERANT CIRCUIT

The refrigerant circuit is difficult to check for leaks without the proper equipment. If inadequate cooling is suspected, contact your local dealer for service.

⚠ WARNING: System under pressure. Relieve pressure and recover all refrigerant before system repair or final unit disposal to avoid serious injury or death. Use all service ports and open all flow-control devices, including solenoid valves.

UNIT PANELS

After performing any maintenance or service on the unit, be sure all panels are fastened securely in place to prevent rain from entering unit cabinet and to prevent disruption of the correct unit airflow pattern.

COMBUSTION AREA AND VENT SYSTEM

The combustion area and vent system should be inspected visually before each heating season. The normal accumulation of dirt, soot, rust, and scale can result in loss of efficiency and improper performance if allowed to build up. This inspection should be done by a trained service person.

⚠ CAUTION: If your unit makes an especially loud noise when the main burners are ignited, shut down the heating section and call your dealer.

⚠ CAUTION: Components in heating section may be hot after unit has been started up. When observing flame, be careful not to get close to or touch heating components of serious injury may result.

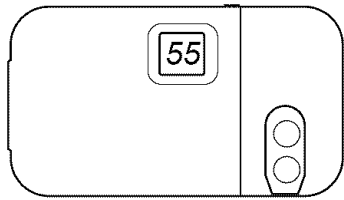

STEP 1

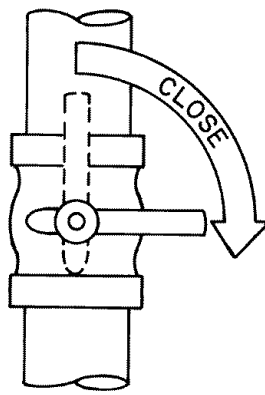

STEP 2

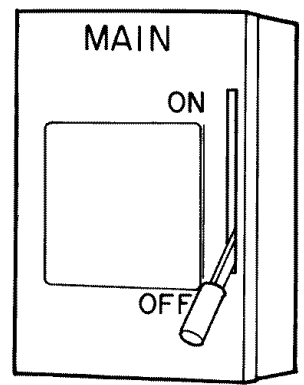

STEP 3

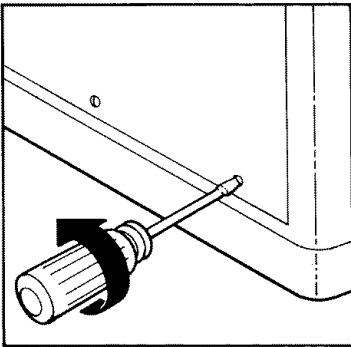

STEP 4

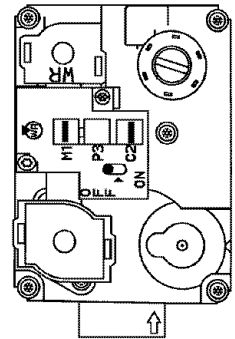
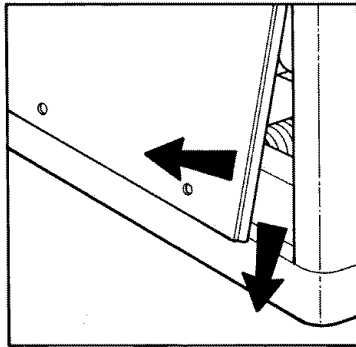

STEP 5

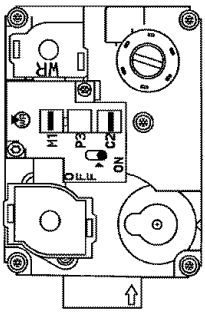

STEP 6

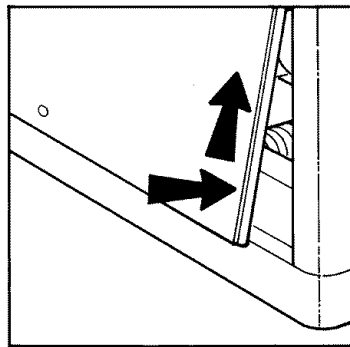

STEP 7

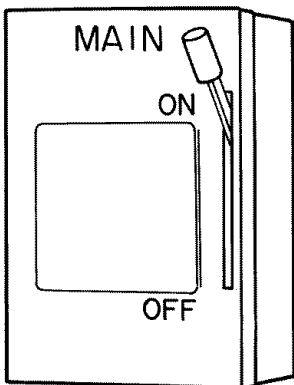
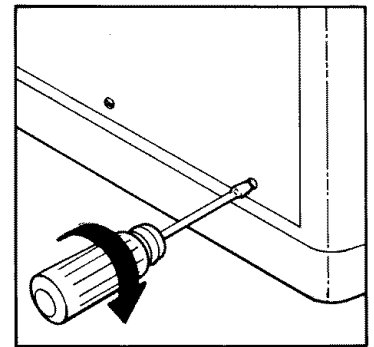

STEP 8

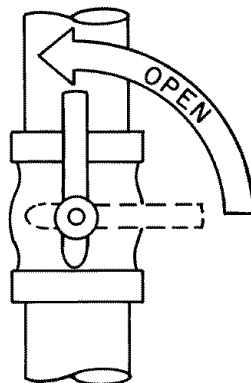

STEP 9

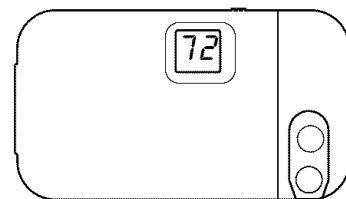

STEP 10

Fig. 3 — To Light Unit

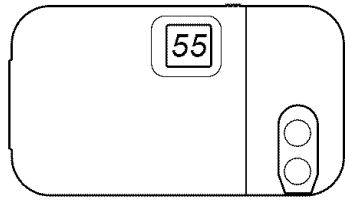

STEP 1

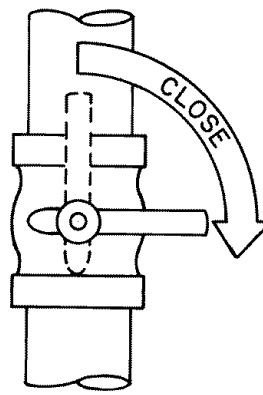

STEP 2

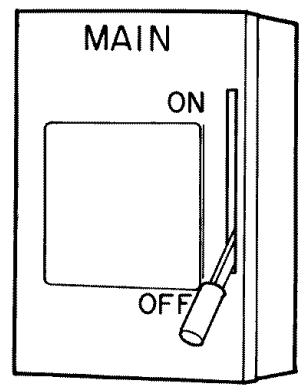

STEP 3

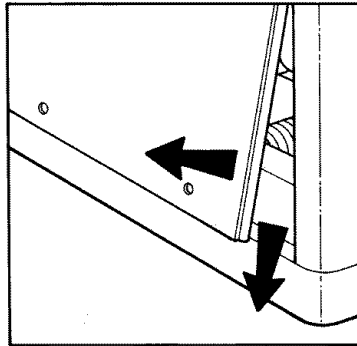
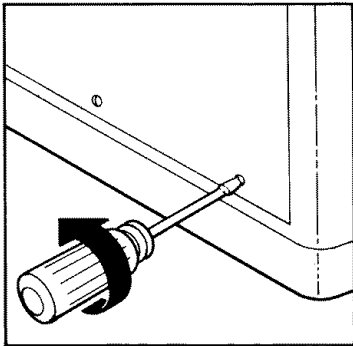

STEP 4

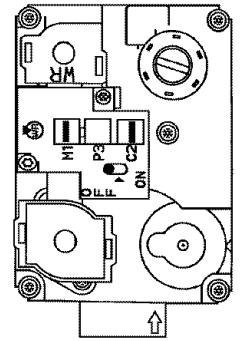

STEP 5

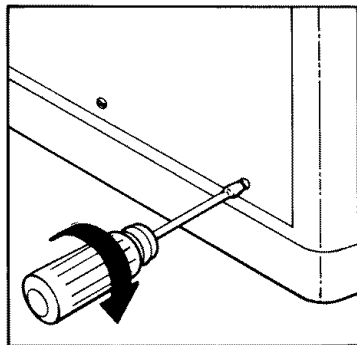
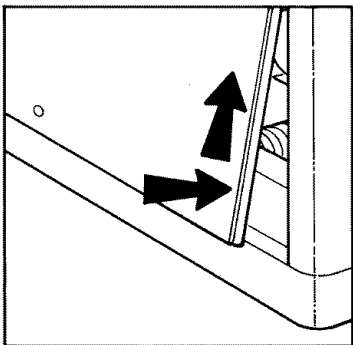

STEP 6

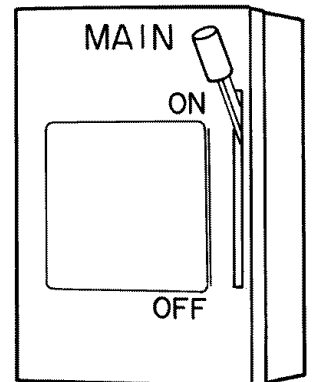

STEP 7

Fig. 4 — To Shut Unit Off

C. Regular Dealer Maintenance

In addition to the type of routine maintenance you might be willing to perform, your unit should be inspected regularly by a properly trained service technician. An inspection (preferably each year, but at least every other year) should include the following:

1. Inspection of all flue product passages-including the burners, heat exchanger, and flue collector box.
2. Inspection of all combustion- and ventilation-air passages and openings.
3. Close inspection of all gas pipes leading to and inside of your unit.
4. Inspection and, if required, cleaning of the outdoor and indoor coils.
5. Inspection and, if required, cleaning of the indoor coil condensate drain.
6. Inspection and cleaning of blower wheel housing and motor.
7. Inspection of all supply-air and return-air ducts for leaks, obstructions, and insulation integrity. Any problems found should be resolved at this time.
8. Inspection of the unit base to ensure that no cracks, gaps, etc., exist which may cause a hazardous condition.
9. Inspection of the unit casing for signs of deterioration.
10. Inspection of all electrical wiring and components to assure proper connection.
11. Inspection for leaks in the refrigerant circuit. Pressure-check to determine appropriate refrigerant charge.
12. Operational check of the unit to determine working conditions. Repair or adjustment should be made at this time.

Your servicing dealer may offer an economical service contract that covers seasonal inspections. Ask for further details.

Complete service instructions can be found in the unit Installation, Start-Up and Service Instructions.

D. Warranty Certificate

Unit PY1P / PY2P has a limited warranty. Be sure to read the warranty carefully to determine the coverage for your unit.

E. Before You Call for Service ...

...check for several easily-solved problems.

If insufficient heating or cooling is suspected:

() Check the air filter for dirt. Check for blocked return-air or supply-air grilles. Be sure they are open and unobstructed. If these checks do not reveal the cause, call your servicing dealer.

If your unit is not operating at all, check the following list for easy solutions:

() Check to be sure that your thermostat temperature selector is set below the indoor temperature during the cooling season or above the indoor temperature during heating season. Be sure the SYSTEM switch or MODE control is in the COOL or HEAT position and not in the OFF position.

() If your unit still fails to operate, call your servicing dealer for troubleshooting and repairs. Specify the model and serial numbers of your unit. (Record them in this manual in the space provided.) If the dealer knows exactly which unit you have, he may be able to offer suggestions over the phone, or save valuable time through knowledgeable preparation for the service call.

F. In Case of Trouble

If you perform the steps above and unit performance is still unsatisfactory, shut off the unit and call your dealer.

Dealer's Name _____

Telephone _____

Unit Model _____

Unit Serial Number _____

