

User Information Manual



Single-Packaged
Heat Pump Units

PH1P-B &
PH2P-B

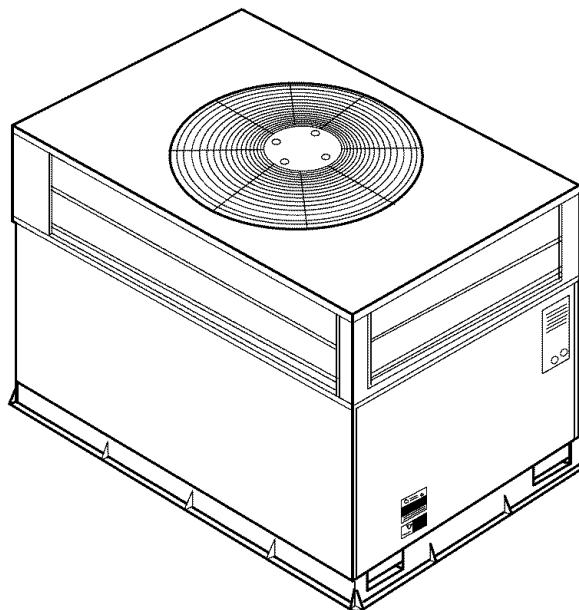

Fig. 1—Unit PH1P-B and PH2P-B

NOTE TO INSTALLER: This manual should be left with the equipment owner.

FOR YOUR SAFETY

Do not store or use gasoline or other flammable vapors and liquids in the vicinity of this or any other appliance.

⚠ WARNING: Do not use this unit if any part has been under water. Immediately call a qualified service technician to inspect the unit and to replace any part of the control system which has been under water. Failure to follow this warning could result in electrical shock, fire, personal injury, or death.

⚠ WARNING: Before performing recommended maintenance, be sure the main power switch to unit is turned off. Electric shock could cause personal injury or death.

WELCOME TO EFFICIENT YEAR-ROUND COMFORT

Congratulations on your excellent choice and sound investment in year-round home comfort!

Your new heat pump represents both the latest in engineering development and the culmination of many years of experience from one of the most reputable manufacturers of comfort systems.

Your new unit is among the most energy-efficient and reliable heat pump products available today. To assure its dependability, spend just a few minutes with this booklet now. Learn about the operation of your heat pump, and the small amount of maintenance it takes to keep it operating at its peak efficiency. With minimal care, your new heat pump will provide you and your family with year-round home comfort—both now and for years to come.

SAFETY CONSIDERATIONS

Recognize safety information. This is the safety-alert symbol . When you see this symbol on unit or in instructions and manuals, be alert to potential for personal injury.

Understand the signal words DANGER, WARNING, and CAUTION. These words are used with the safety-alert symbol. DANGER identifies the most serious hazards which will result in severe personal injury or death. WARNING signifies hazards which could result in personal injury or death. CAUTION is used to identify unsafe practices which would result in minor personal injury or product and property damage. NOTE is used to highlight suggestions which will result in enhanced installation, reliability, or operation.

⚠ WARNING: Improper installation, adjustment, alteration, service, maintenance, or use can cause explosion, fire, electrical shock, or other conditions which may cause serious injury, death or property damage. Consult a qualified installer, service agency, or your distributor or branch for information or assistance. The qualified installer or agency must use factory-authorized kits or accessories when modifying this product.

YOUR COMFORT SYSTEM

PROCEDURE 1—IDENTIFYING YOUR SYSTEM

Take the time to familiarize yourself with your packaged heat pump type of system. This knowledge will be of use in understanding the basic operation of your new heat pump. The unit has a rating plate affixed to it which provides necessary information for specific identification of a unit. You should familiarize yourself with the product, model, and serial numbers listed on each rating plate. Record them for future reference in the space provided at the end of this booklet.

IMPORTANT FACTS

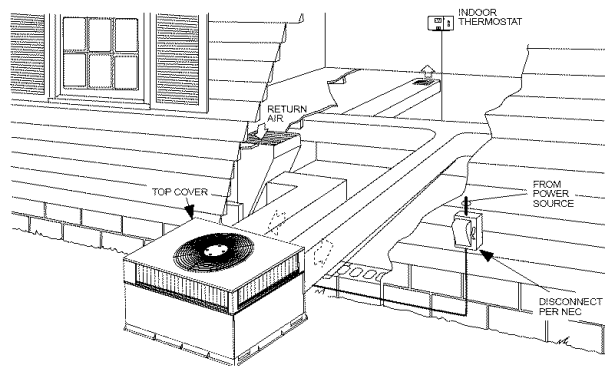

Fig. 2—Typical Installation

To better protect your investment and to eliminate unnecessary calls, familiarize yourself with the following facts:

1. Your heat pump system should never be operated without a clean air filter properly installed. Plan to inspect the filter periodically. A clogged air filter will increase operating costs and shorten the life of the unit.
2. Supply-air and return-air registers should not be blocked. Drapes, furniture, and toys are some of the items commonly found obstructing registers. Restricted airflow lessens the unit's efficiency and life span.
3. The outdoor unit must have unrestricted airflow. Do not cover the unit, lean anything against it, or stand on it. Do not allow grass clippings, leaves, or other debris to accumulate around on top of the unit. Maintain a 12-in. minimum clearance between the outdoor unit and tall grass, vines, shrubs, etc.
4. Your multipurpose indoor thermostat is the control center for your heat pump system. You should familiarize yourself with its proper operation. Attempting to control the system by other means—for instance, switching the electrical supply power ON and OFF—may cause damage to the unit. (See Fig. 4 and 5.)
5. During heating, increasing the thermostat setting more than 2 degrees may cause the supplemental heaters to be turned on for a short period of time to satisfy the thermostat. Needless use of the supplementary heat reduces potential energy savings.
6. You may find that you can maintain greater personal comfort by running the fan continuously. "Air pockets" can form due to the structure of the house, placement of registers, etc. air pockets may be too cool or warm for your liking. Continuous fan operation minimizes any temperature differences. Also, systems equipped with electronic or mechanical air cleaners and/or humidifiers offer the added benefits of having the air continuously cleaned year-round and humidified during the winter season.
7. A system equipped with a heat or energy recovery ventilator offers the advantage of exhausting stale air from the home and allowing fresh air in from the outdoors while minimizing heat loss.
8. Your system may also be equipped with a zoning system which allows individual control over the temperatures of separate areas of your home.
9. Your heat pump will remove humidity from your home during the cooling season. After a few minutes of operation, you should be able to see water trickle from the condensate drain. Check this occasionally to be sure the drain system is not clogged. Of course, don't expect to see much drainage if you live in a very dry environment.
10. During the heating cycle, air from your registers may seem cooler than you might first expect. This is because your heat pump delivers a constant flow of air at around 90°F to 105°F instead of sudden bursts of hot air as with a conventional furnace. This air may feel cooler because it is slightly less than your skin temperature. However, it is sufficiently warm to keep you comfortable.

11. Ice or frost will tend to form on the coil during the winter heating operation. Your heat pump is designed to automatically melt the ice. When in this defrost cycle, it is normal for steam or fog to rise from the outdoor unit. Do not be alarmed!
12. Do not operate your unit in cooling mode when outdoor temperatures are below 40°F unless your unit was modified for low-ambient operation.
13. Do not operate your unit in heating mode when outdoor temperatures are above 66°F unless you set your thermostat to emergency heat mode.

⚠ WARNING: To prevent serious injury, death, or property damage, read and follow all instructions and warnings, including labels shipped with or attached to unit before operating your new heat pump.

OPERATING YOUR HEAT PUMP

The operation of your heat pump system is controlled by the indoor thermostat. You simply adjust the thermostat and it maintains the indoor temperature at the level you select. Most thermostats for heat pump systems have 3 controls: a temperature control selector, a FAN control, and a SYSTEM or MODE control.

PROCEDURE 1—COOLING MODE

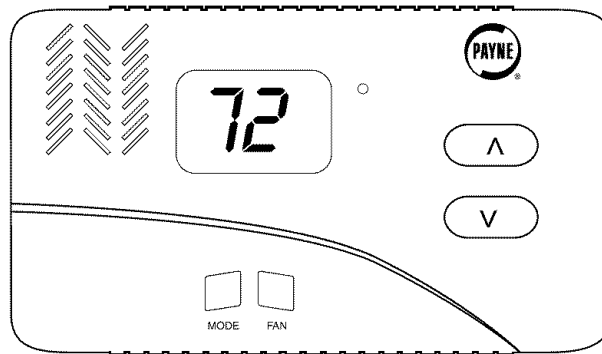

Fig. 3—Payne Non-Programmable Thermostat

When operating in cooling mode, your heat pump will run in cooling mode until the indoor temperature is lowered to the level you have selected. On extremely hot days, your heat pump will run for longer periods at a time and have shorter “off” periods than on moderate days.

The following are typical conditions that add extra heat and/or humidity to your home. Your heat pump will work longer to keep your home comfortable under these conditions:

1. Entrance doors are frequently opened and closed
2. Laundry appliances are being operated
3. A shower is running
4. More than the usual number of people are present in the home
5. More than the normal number of electric lights are in use
6. Drapes are open on the sunny side of the home

PROCEDURE 2—HEATING MODE

With the SYSTEM or MODE control of your indoor thermostat set to HEAT, your heat pump will run in heating mode until room temperature is raised to the level you have selected. Of course, your heat pump will have to operate for longer periods to maintain a comfortable environment on cooler days and nights than on moderate ones.

PROCEDURE 3—SUPPLEMENTAL HEAT

Your heat pump is your primary heating source. Your system may also be equipped with a supplemental heating source such as electric heat. On cold days and nights, your system will automatically turn on the supplemental heat in order to maintain the level of comfort you have selected.

When your heat pump needs additional heat to keep you comfortable, your Payne electronic thermostat will turn on the supplemental heat (if equipped) and will display the “AUX HT” message.

PROCEDURE 4—DEFROST MODE

When your heat pump is providing heat to your home and the outdoor temperature drops below 45°F, moisture may begin to freeze on the surface of the coil. If allowed to build up, this ice would impede airflow across the coil and reduce the amount of heat absorbed from the outside air. So, to maintain energy-efficient operation, your heat pump has an automatic defrost mode. The defrost mode starts at a preset time interval of 90 minutes, although, it may be reset to either 30 or 50 minutes. Defrost will start at the preset time only if the ice is sufficient to interfere with normal heating operation. After the ice is melted from the coil, or after a maximum of 10 minutes in defrost mode, the unit automatically switches back to normal heating operation.

Do not be alarmed if steam or fog appears at the outdoor unit during defrost mode. Water vapor from the melting ice may condense into a mist in the cold outside air. During certain weather conditions such as heavy snow and freezing rain it is not uncommon for ice to build up on the unit grille. This is normal for these weather conditions. Do not attempt to remove the ice from the unit grille. This condition will not affect the proper function of the unit and will clear a few days.

PERFORMING ROUTINE MAINTENANCE

With the proper maintenance and care, your heat pump will operate economically and dependably. Maintenance can be accomplished easily by referring to the following directions. However, before performing maintenance, consider these important safety precautions:

⚠ WARNING: Disconnect all electrical power to the indoor air handler or furnace before removing access panels to perform any maintenance. Disconnect power to both the indoor and outdoor units. Note: There may be more than 1 electrical disconnect switch. Electrical shock can cause serious injury or death.

⚠ CAUTION: Although special care has been taken to minimize sharp edges in the construction of your unit, to avoid injury be extremely careful when handling parts or reaching into the unit.

PROCEDURE 1—CHECK THE AIR FILTER

A dirty air filter will cause excessive strain on the compressor and blower motor. This can cause the components to overheat and automatically shut down. In the worst case, the components will fail and need to be replaced. To avoid inefficient or failed operation of your unit, CHECK THE FILTER(S) EVERY 3 TO 4 WEEKS. Replace filter(s) when necessary, or clean the filter(s) if you have the reusable type.

Disposable filters should be replaced by similar, new filters of the same dimensions.

Reusable, permanent filters should be washed in a solution of cold water and mild detergent, then rinsed and thoroughly dried. THE FILTER MUST BE COMPLETELY DRY BEFORE BEING REINSTALLED. To avoid prolonged shutdown of your unit while a filter is drying, you should have an extra filter on hand. This allows you to rotate between the two with minimal downtime for your comfort system. Extra filters may be purchased from your dealer.

Table 1—Filter Size Data

UNIT SIZE	FILTER SIZE
PH1PB018-30	20x20
PH1PB036	20x24
PH1PB042-060	24x30
PH2P024-030	20x20
PH2P036	20x24
PH2P042-060	24x30

The filter(s) and filter rack for a packaged system are supplied and installed by the contractor or dealer. Typically, the filter(s) and rack are located in the return-air duct at the outdoor unit or behind the return-air grille(s). Have your dealer show you the location of your filter(s) and the procedures for removal and replacement.

If your system includes a high efficiency or electronic air cleaner, refer to air cleaner User's Manual for proper filter cleaning or replacement.

PROCEDURE 2—OUTDOOR COIL

If grass clippings, leaves, shrubbery, and debris are kept away from the unit, minimal care should be sufficient to keep the system functioning properly. However, if the outdoor coil becomes dirty, use a vacuum cleaner or shop vac with soft brush attachment to clean the exterior surface. Vacuum coil surface using an up and down motion. Be careful not to bend or damage fins.

If dirt is deep in the coil, contact your dealer for service. Do not attempt this yourself.

PROCEDURE 3—OUTDOOR COIL—SEA COAST

If your unit is located near the ocean, special maintenance is required. Ocean mist/breeze carries salt, which is corrosive to most metals. Although your new unit is made out of galvanized metal and is protected by top-grade paint, you should take the precaution of additional maintenance which consists of periodically washing the unit. By washing all exposed surfaces and coil, you will be adding additional life to your unit. Please consult your installing contractor for proper intervals/procedures for your geographic area or service contact.

PROCEDURE 4—UNIT SUPPORT

Your packaged heat pump unit should be maintained at a level position. If its support should shift or settle so that the unit is no longer level, you should correct the condition. Relevel it promptly to assure water drains out of the unit. If you notice that water or ice collects beneath the unit, arrange for it to be drained away from the unit.

BEFORE YOUR REQUEST A "SERVICE CALL" CHECK FOR THESE EASILY SOLVED PROBLEMS:

1. Check the indoor and outdoor disconnect switches. Verify that circuit breakers are ON or that fuses have not blown.
2. Check for sufficient airflow. Check the air filter(s) for any accumulations of dirt. Check for blocked return-air or supply-air registers. Be sure registers are open and unobstructed.
3. Check the settings on your indoor thermostat. If you desire cooling, make sure that the temperature control selector is set below room temperature and the SYSTEM or MODE control is set to COOL or AUTO. If you require warmth, make sure that the temperature control selector is set above room temperature and the SYSTEM or MODE control is set to HEAT or AUTO. The FAN control should be set to ON for continuous blower operation or AUTO if you wish blower to function only while your heat pump is operating. If your comfort system still fails to operate, turn your system off and contact your servicing dealer for troubleshooting and repairs. Specify your apparent problem, and state the model and serial number of your equipment. (You should have them recorded on the last page of this booklet.) With this information, your dealer may be able to offer helpful suggestions over the phone or save valuable time through knowledgeable preparation for the service call.

REGULAR DEALER MAINTENANCE

In addition to the routine maintenance that you perform, your home comfort system should be inspected regularly by a properly trained service technician. The inspection (preferably twice each year, but at least once every year) should include the following:

1. Routine inspection of air filter(s). Replacement or cleaning as required.
2. Inspection and cleaning of the blower wheel, housing, and motor as required.
3. Inspection and, if required, cleaning of coils.
4. A check of all electrical wiring and connections.
5. A check for secure physical connections of individual components within unit.
6. Operational check of the heat pump system to determine actual working condition. Necessary repair and/or adjustment should be performed at this time.
7. Your servicing dealer may offer an economical service contract that covers seasonal inspections. Ask for further details.

WARRANTIES

You have purchased either a PH1P-B or PH2P-B series unit. Be sure to read the warranty at the back of this booklet carefully to determine the coverage for your unit.

FOR THE RECORD

Record the model, product, and serial numbers of your new equipment in the spaces provided. This information, along with the other ready-reference facts requested will be necessary should you ever require information or service.

INSTALLATION DATA

Date Installed.....
Dealer's Name.....
Address.....
City.....
State/Zip.....
Telephone.....

UNIT DATA

Unit Model.....
Unit Serial Number.....
Heater, if applicable:
Part Number.....
Kilowatt Rating.....

