

# **NordicTrack**<sup>®</sup> *GRT470*

Patent Pending

Model No. NTSY73690

Serial No. \_\_\_\_\_

The serial number is found in the location shown below. Write the serial number in the space above.

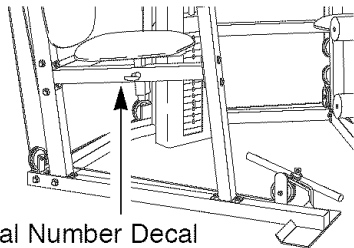

Serial Number Decal

## **USER'S MANUAL**

### **QUESTIONS?**

As a manufacturer, we are committed to providing complete customer satisfaction. If you have questions, or if there are missing parts, we will guarantee complete satisfaction through direct assistance from our factory.

**TO AVOID UNNECESSARY DELAYS, PLEASE CALL DIRECT TO OUR TOLL-FREE CUSTOMER HOT LINE.** The trained technicians on our customer hot line will provide immediate assistance, free of charge to you.

**CUSTOMER HOT LINE:**

**1-888-825-2588**

Mon.-Fri., 6 a.m.-6 p.m. MST

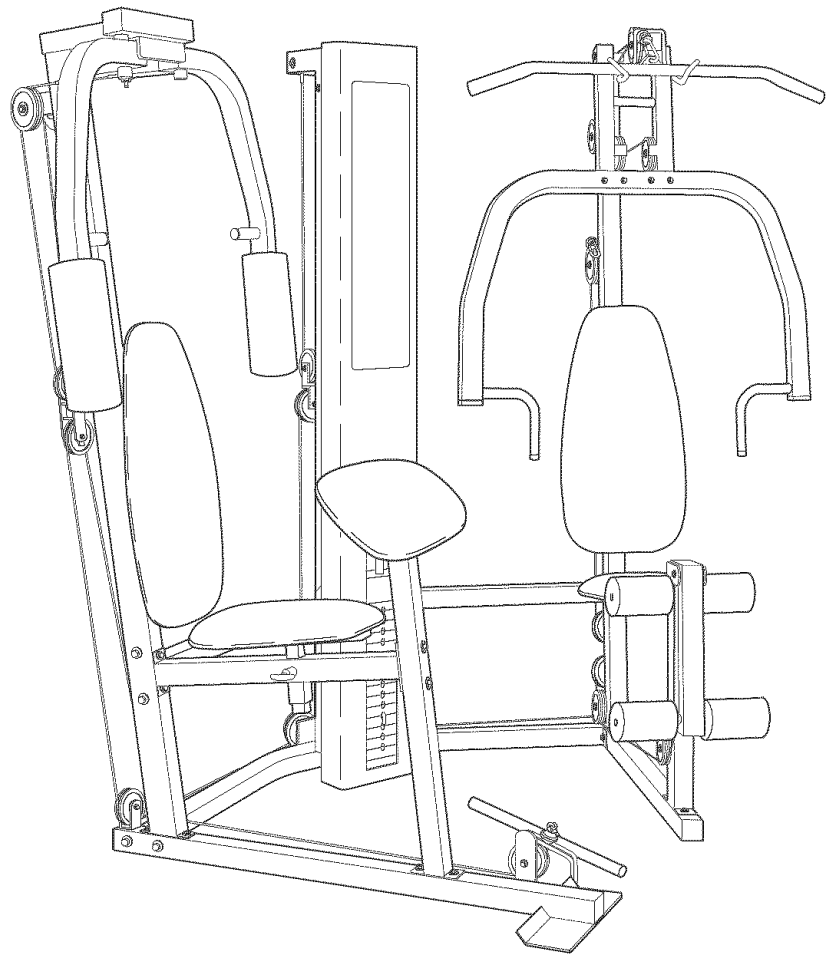

### **CAUTION**

Read all precautions and instructions in this manual before using this equipment. Save this manual for future reference.



Visit our website at

[www.nordictrack.com](http://www.nordictrack.com)

new products, prizes,  
fitness tips, and much more!

# Table of Contents

Important Precautions	2
Before You Begin	3
Assembly	4
Weight Resistance Chart	23
Cable Diagrams	24
Adjustment	26
Trouble-shooting and Maintenance	27
Ordering Replacement Parts	Back Cover
Limited Warranty	Back Cover

Note: A Part List/Exploded Drawing and a Part Identification Chart are attached in the center of this manual.

## Important Precautions

**WARNING:** To reduce the risk of serious injury, read the following important precautions before using the home gym.

1. It is the responsibility of the owner to ensure that all users of the home gym are adequately informed of all precautions.
2. Read all instructions in this manual and in the accompanying literature before using the home gym.
3. The home gym is intended for home use only. Do not use the home gym in a commercial, rental or institutional setting.
4. Use the home gym only on a level surface. Cover the floor or carpet beneath the home gym for protection.
5. Inspect and tighten all parts often. Replace any worn parts immediately.
6. Make sure that the cables remain on the pulleys at all times. If the cables bind while you are exercising, stop immediately and make sure the cables are on all of the pulleys.
7. Always stand on the foot plate when performing an exercise that could cause the home gym to tip.
8. Keep hands and feet away from moving parts.
9. Keep children under the age of 12 and pets away from the home gym at all times.
10. Always wear athletic shoes for foot protection when exercising.
11. Never release the press arms, butterfly arms, leg lever, lat bar, row bar, or ab strap while weights are raised. The weights will fall with great force.
12. If you feel pain or dizziness while exercising, stop immediately and begin cooling down.
13. Always disconnect the lat bar, row bar, or ab strap from the home gym when performing exercises that do not use these attachments.
14. The decal shown at the right has been attached to the home gym in the two locations shown on page 3. If a decal is missing or illegible, please call toll-free 1-888-825-2588 to order a free replacement decal. Apply the decal in the location shown.

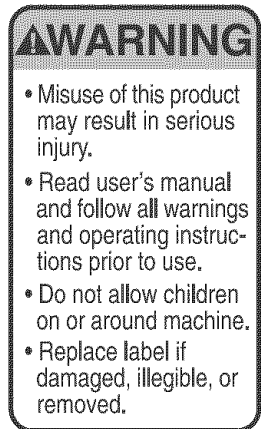

**WARNING:** Before beginning this or any exercise program, consult your physician. This is especially important for persons over the age of 35 or persons with pre-existing health problems. Read all instructions before using. ICON assumes no responsibility for personal injury or property damage sustained by or through the use of this product.

# Before You Begin

Thank you for selecting the innovative and versatile NordicTrack® GRT470 home gym. The NordicTrack GRT470 offers a large selection of weight stations designed to develop every major muscle group of the body. Whether your goal is to tone your body, build dramatic muscle size and strength, or improve your cardiovascular system, the NordicTrack GRT470 will help you to achieve the results you want.

**For your benefit, read this manual carefully before using the Nordictrack GRT470.** If you have addition-

al questions, please call our Customer Service Department toll-free at 1-888-825-2588, Monday through Friday, 6 a.m. until 6 p.m. Mountain Time (excluding holidays). To help us assist you, please note the product model number and serial number before calling. The model number is NTSY73690. The serial number can be found on a decal attached to the home gym (see the front cover of this manual).

**Before reading further, please familiarize yourself with the parts that are labeled in the drawing below.**

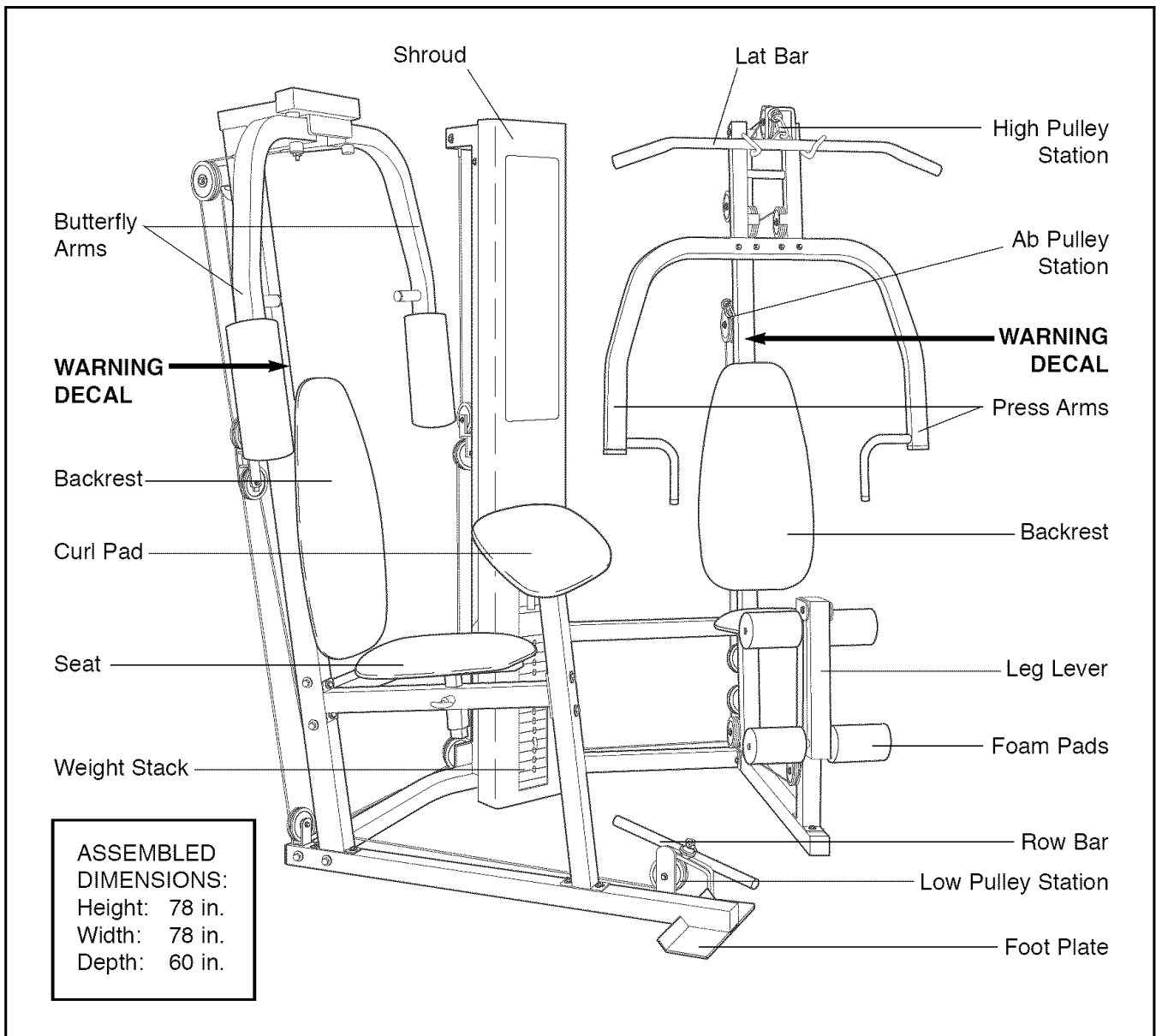

# Assembly

## Make Assembly Easier for Yourself!

Everything in this manual is designed to ensure that the home gym can be assembled successfully by anyone. **Before beginning assembly, make sure to read the information on this page; this brief introduction will save you much more time than it takes to read it!**

## Assembly Requires Two Persons

For your convenience and safety, assemble the home gym with the help of another person.

## Set Aside Enough Time

Due to the many features of the home gym, the assembly process will require about six hours. By setting aside plenty of time and by deciding to make the task enjoyable, assembly will go smoothly. You may want to assemble the home gym over a couple of evenings.



## Select a Location for the Home Gym

Because of its weight and size, the home gym should be assembled in the location where it will be used. Make sure that there is enough room to walk around the home gym as you assemble it.

## How to Unpack the Box

To make assembly as easy as possible, we have divided the assembly process into four stages. The parts needed for each stage are found in individual bags. **Important: Wait until you begin each stage to open the part bag for that stage.** Place all parts of the home gym in a cleared area and remove the packing materials. Do not dispose of the packing materials until assembly is completed.

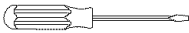
## Make sure you have the following tools:

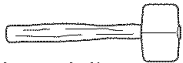
- Two (2) adjustable wrenches 
- One (1) standard screwdriver 
- One (1) phillips screwdriver 
- One (1) rubber mallet 
- You will also need grease or petroleum jelly, a small amount of soapy water, and clear tape or masking tape.

Note: Assembly will be more convenient if you have a socket set, a set of open-end or closed-end wrenches, or a set of ratchet wrenches.

## How to Identify Parts

To help you identify the small parts used in assembly, we have included a PART IDENTIFICATION CHART in the center of this manual. Place the chart on the floor and use it to easily identify parts during each assembly step. **Note: Some small parts may have been pre-attached. If a part is not in the part bag, check to see if it has been pre-attached.**

## How to Orient Parts

As you assemble the home gym, make sure that all parts are oriented exactly as shown in the drawings.

## Tightening Parts

Tighten all parts as you assemble them, unless instructed to do otherwise.

## Questions?

If you have questions after reading the assembly instructions, please call our Customer Service Department toll-free at **1-888-825-2588**, Monday through Friday, 6 a.m. until 6 p.m. Mountain Time.

## The Four Stages of the Assembly Process

**Frame Assembly**—You will begin by assembling the base and the uprights that form the skeleton of the home gym.

**Arm Assembly**—During this stage you will assemble the press arms and the butterfly arms.

**Cable Assembly**—During this stage you will attach the cables and pulleys that connect the arms to the weights.

**Seat Assembly**—During the final stage you will assemble the seat and the backrest.

# Frame Assembly

1. **Before you begin this step, make sure that you have read all of the information on page 4. This introduction will save you much more time than it takes to read it!**

Locate and open the parts bags labeled “FRAME ASSEMBLY METAL” and “FRAME ASSEMBLY PLASTIC.”

See drawing 1a. Press a 2” Square Inner Cap (28) into each end of the Butterfly Base (4).

Insert four 5/16” x 2 1/2” Carriage Bolts (92) up through the indicated holes in the Butterfly Base (4). **Note: If the Bolts fall out, secure them by putting a small piece of tape over the head of each Bolt.** Place the Butterfly Base flat on the floor.

Insert two 5/16” x 2 1/2” Carriage Bolts (92) up through the indicated holes in the Weight Base (5). Place the Weight Base flat on the floor.

See drawing 1b. Attach the Weight Base (5) to the Butterfly Base (4) with two 5/16” x 2 3/4” Bolts (89), two 5/16” Washers (36), and two 5/16” Nylon Locknuts (64).

2. See drawing 2a. Press a 2” Square Inner Cap (28) into each end of the Press Base (6).

Insert four 5/16” x 2 1/2” Carriage Bolts (92) up through the indicated holes in the Press Base (6).

See drawing 2b. Attach the Press Base (6) to the Weight Base (5) with two 5/16” x 2 3/4” Bolts (89), two 5/16” Washers (36), and two 5/16” Nylon Locknuts (64).

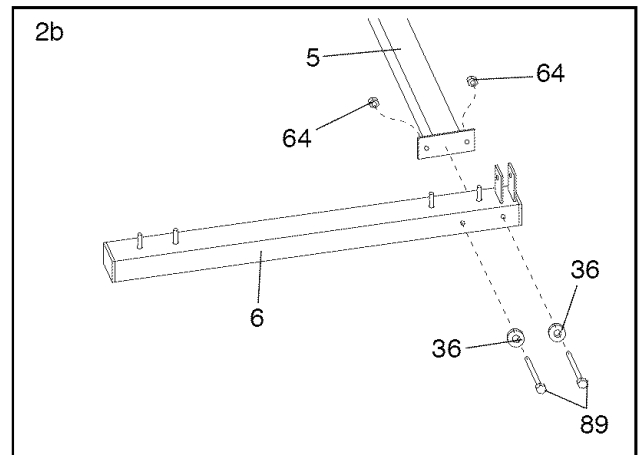
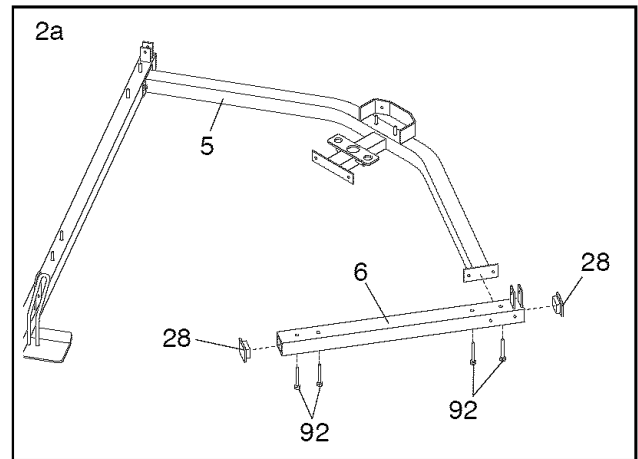
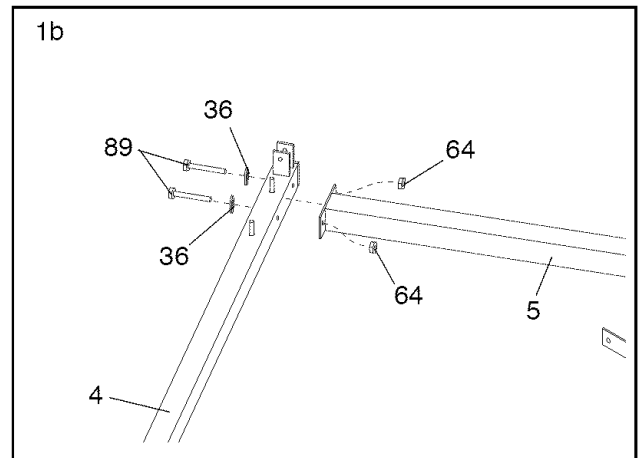
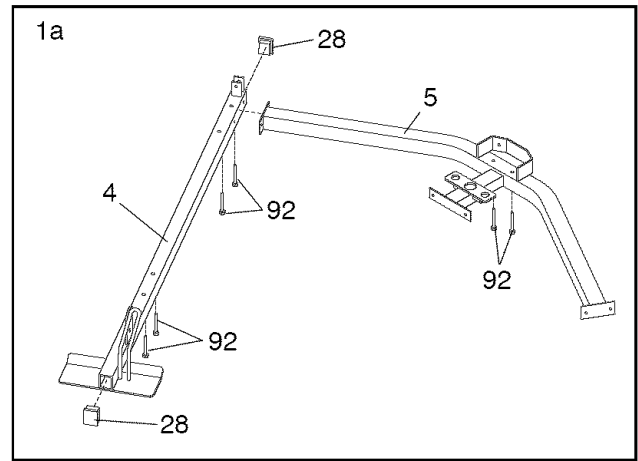

3. Press three 2" Square Inner Caps (28) into the Butterfly Upright (1).

Place the bracket on the lower end of the Butterfly Upright (1) over the indicated 5/16" x 2 1/2" Carriage Bolts (92) in the Butterfly Base (4). Hand tighten two 5/16" Nylon Locknuts (64) onto the Bolts.

Thread an Adjustment Handle (85) into the indicated hole in the Butterfly Upright (1).

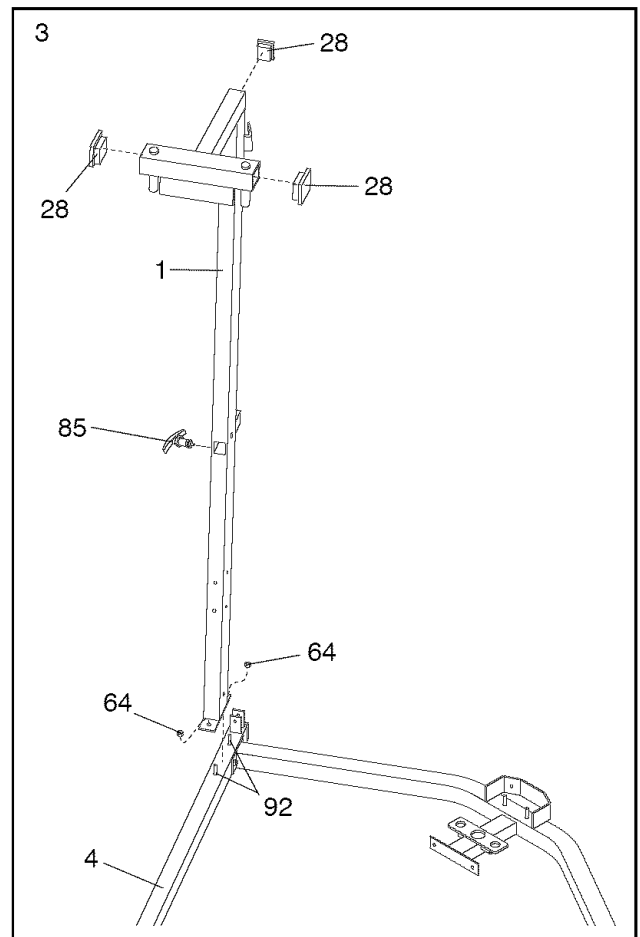

4. Press a 2" Square Inner Cap (28) into the Weight Upright (9).

Place the bracket on the lower end of the Weight Upright (9) over the indicated 5/16" x 2 1/2" Carriage Bolts (92) in the Weight Base (5). Hand tighten two 5/16" Nylon Locknuts (64) onto the Bolts.

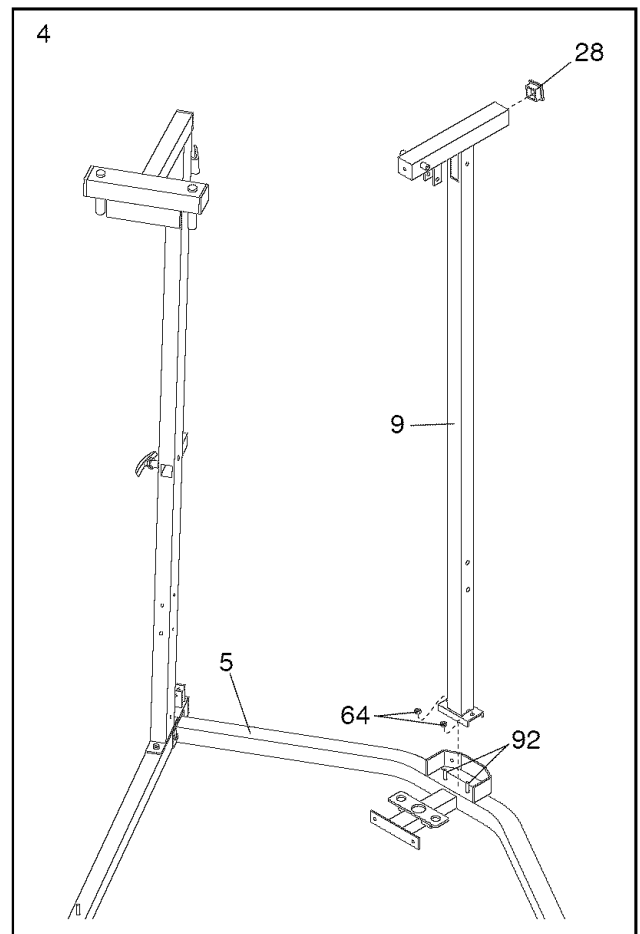

5. Press two 2" Square Inner Caps (28) into the Press Upright (2). Press a 1 3/4" Square Inner Cap (35) into the welded tube on the Press Upright.

Place the bracket on the lower end of the Press Upright (2) onto the indicated 5/16" x 2 1/2" Carriage Bolts (92) and secure it with two 5/16" Nylon Locknuts (64).

Thread an Adjustment Handle (85) into the indicated hole in the Press Upright (2).

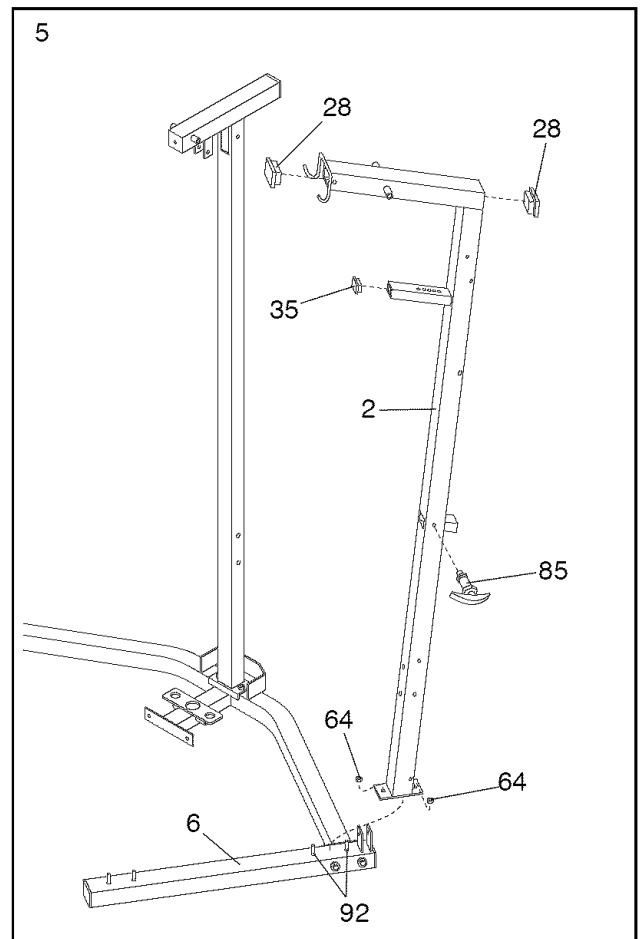

6. With a second person holding the Right Support Frame (33) in position, attach the Right Support Frame to the Butterfly Upright (1) with two 5/16" x 2 3/4" Bolts (89), two 5/16" Washers (36), and two 5/16" Nylon Locknuts (64). **Do not tighten the Nylon Locknuts yet.**

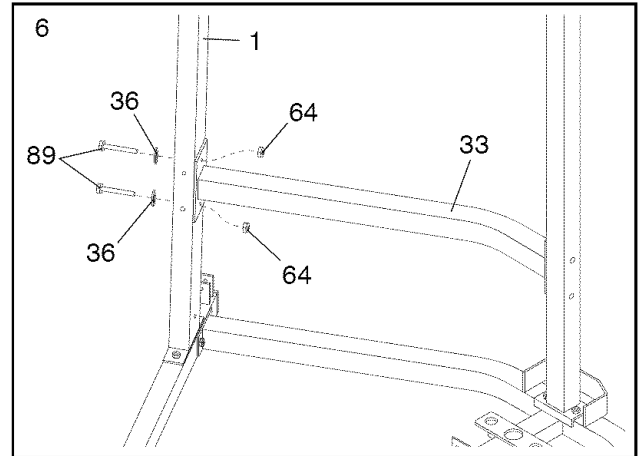

7. While a second person holds the Left Support Frame (97) in position, attach the Left Support Frame to the Press Upright (2) with two 5/16" x 2 3/4" Bolts (89), two 5/16" Washers (36), and two 5/16" Nylon Locknuts (64). **Do not tighten the Nylon Locknuts yet.**

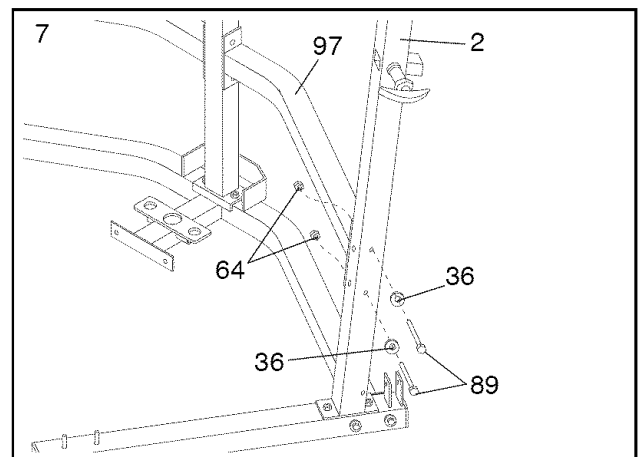

8. Attach the Right Support Frame (33) and the Left Support Frame (97) to the Weight Upright (9) with two 5/16" x 2 3/4" Bolts (89) and two 5/16" Nylon Locknuts (64). **Tighten all Nylon Locknuts used in steps 6 through 8.**

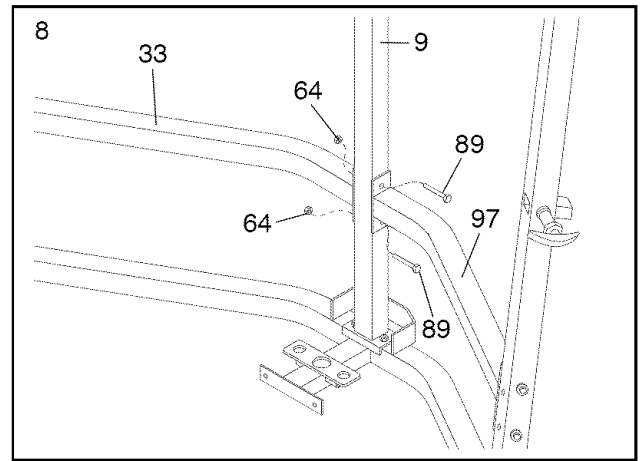

9. Slide the Butterfly Front Leg (3) onto the indicated 5/16" x 2 1/2" Carriage Bolts (92) in the Butterfly Base (4). Hand tighten two 5/16" Nylon Locknuts (64) onto the Bolts. **Do not tighten the Nylon Locknuts yet.**

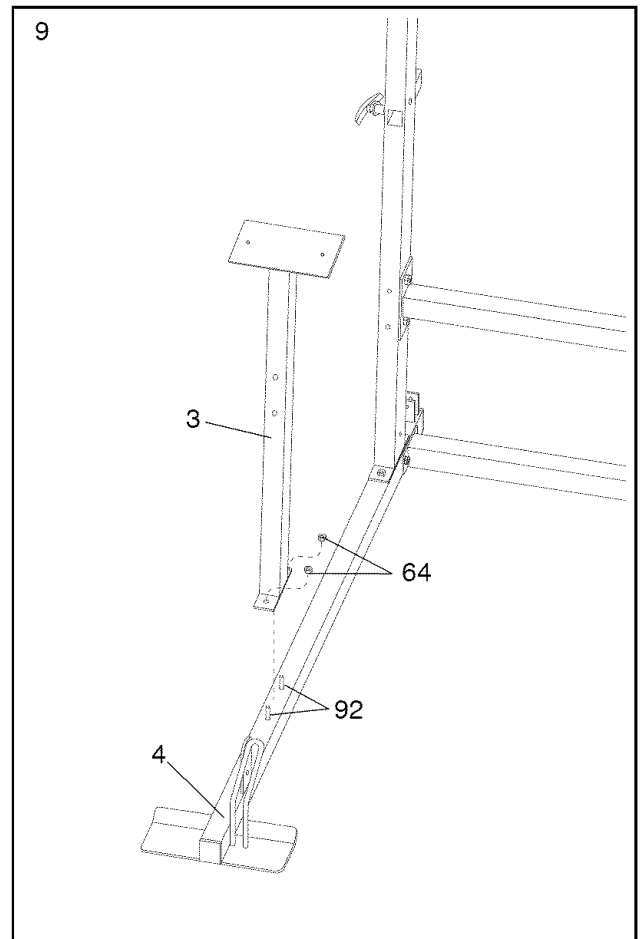

10. Thread an Adjustment Handle (85) into the indicated hole in the Butterfly Seat Frame (14).

Attach the Butterfly Seat Frame (14) to the Butterfly Front Leg (3) with two 5/16" x 2 3/4" Bolts (89), two 5/16" Washers (36), and two 5/16" Nylon Locknuts (64). **Do not tighten the Nylon Locknuts yet.**

Attach the Butterfly Seat Frame (14) to the Butterfly Upright (1) with two 5/16" x 3 3/4" Bolts (66), two 5/16" Washers (36), and two 5/16" Nylon Locknuts (64). **Tighten all Nylon Locknuts used in steps 9 and 10.**

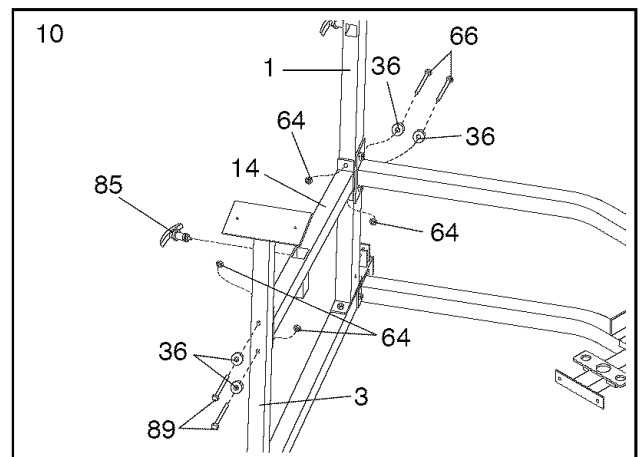



11. Place two Weight Bumpers (51) over the indicated holes in the bracket on the Weight Base (5). Insert the Weight Guides (15) into the holes.

See the inset drawing. Insert two Weight Inserts (94) into each Weight (21) as shown. Turn the Weights so the large pin grooves point toward the floor.

Slide all of the included Weights (21) onto the Weight Guides (15). **Make sure that the Weights are turned so the pin grooves are on the side shown.**

Press a Weight Tube Bumper (18) into the lower end of the Weight Tube (17). Slide the Top Weight assembly (16) onto the Weight Guides (15).

Attach the Weight Guides (15) to the welded tube on the Weight Base (5) with a 3/8" x 6 1/2" Bolt (55) and a 3/8" Nylon Locknut (50).

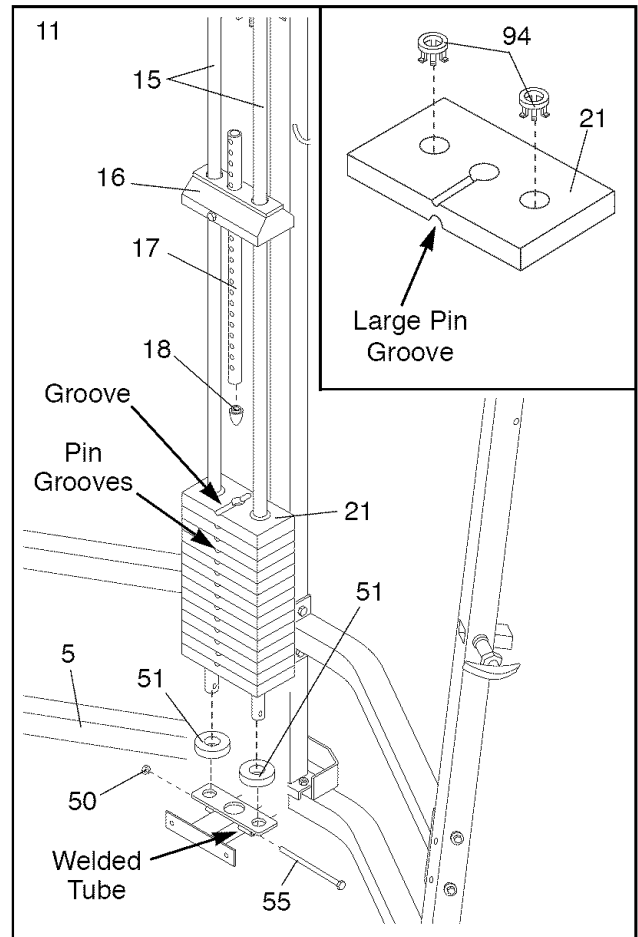

12. Attach the Weight Guides (15) to the welded tube on the Weight Upright (9) with a 3/8" x 6 1/2" Bolt (55) and a 3/8" Nylon Locknut (50).

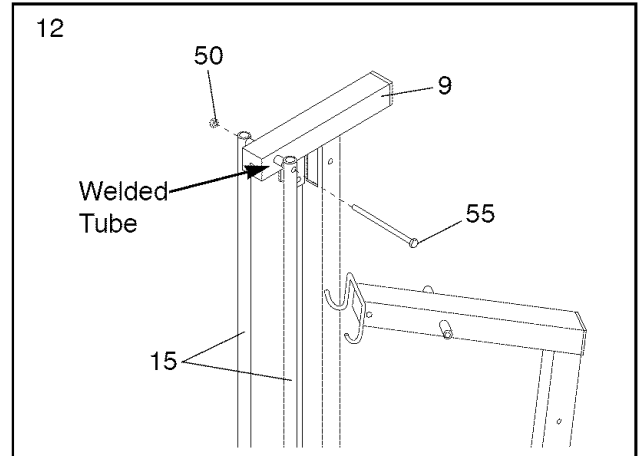

13. Press a 2" Square Inner Cap (28) into the top of the Press Front Leg (20).

Slide the Press Front Leg (20) onto the indicated 5/16" x 2 1/2" Carriage Bolts (92) in the Press Base (6). Hand tighten two 5/16" Nylon Locknuts (64) onto the Bolts. **Do not tighten the Nylon Locknuts yet.**

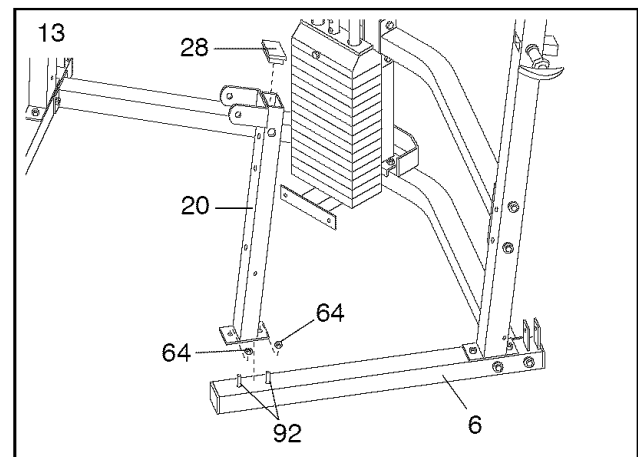

14. Hold the Press Seat Frame (7) between the Press Front Leg (20) and the Press Upright (2) so that the hole that is closest to the welded plate is facing the Press Front Leg. Attach the Press Seat Frame to the Press Front Leg with two 5/16" x 2 3/4" Bolts (89), two 5/16" Washers (36), and two 5/16" Nylon Locknuts (64). **Do not tighten the Nylon Locknuts yet.**

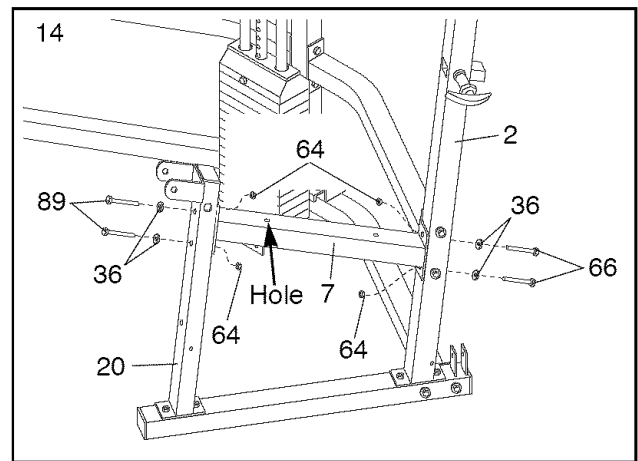

Attach the Press Seat Frame (7) to the Press Upright (2) with two 5/16" x 3 3/4" Bolts (66), two 5/16" Washers (36), and two 5/16" Nylon Locknuts (64). **Tighten all Nylon Locknuts used in steps 13 and 14.**

15. Attach a Bumper (40) to the indicated hole in the Press Front Leg (20) with a #10 x 1" Screw (80).

Press a 2" Square Inner Cap (28) into each end of the Leg Lever (41).

Lubricate the 3/8" x 3 1/4" Bolt (62). Attach the Leg Lever (41) to the Press Front Leg (20) with the Bolt and a 3/8" Nylon Locknut (50). **Do not overtighten the Nylon Locknut; it must be easy to pivot the Leg Lever.**

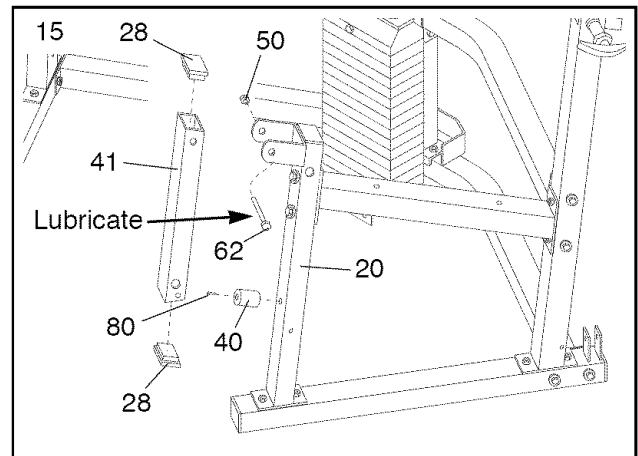

## Arm Assembly

16. Press a 2" Square Inner Cap (28) into each end of the Right Butterfly Arm (10). Wet the lower end of the Right Butterfly Arm with soapy water. Slide a Butterfly Foam Pad (29) onto the lower end of the Right Butterfly Arm.

Lubricate the indicated axle on the Butterfly Upright (1). Orient the Right Butterfly Arm (10) as shown and slide it onto the axle. Secure the Butterfly Arm with two Retainer Rings (31) and a 1" Round Outer Cap (38) in the following way: **Place the Retainer Rings on top of the inverted Round Outer Cap, making sure that the teeth on the Retainer Rings bend towards the Round Outer Cap as shown in the inset drawing. Gently tap the Round Outer Cap onto the axle with a hammer.**

Attach the Left Butterfly Arm (11, not shown) on the opposite side by following the procedure described above.

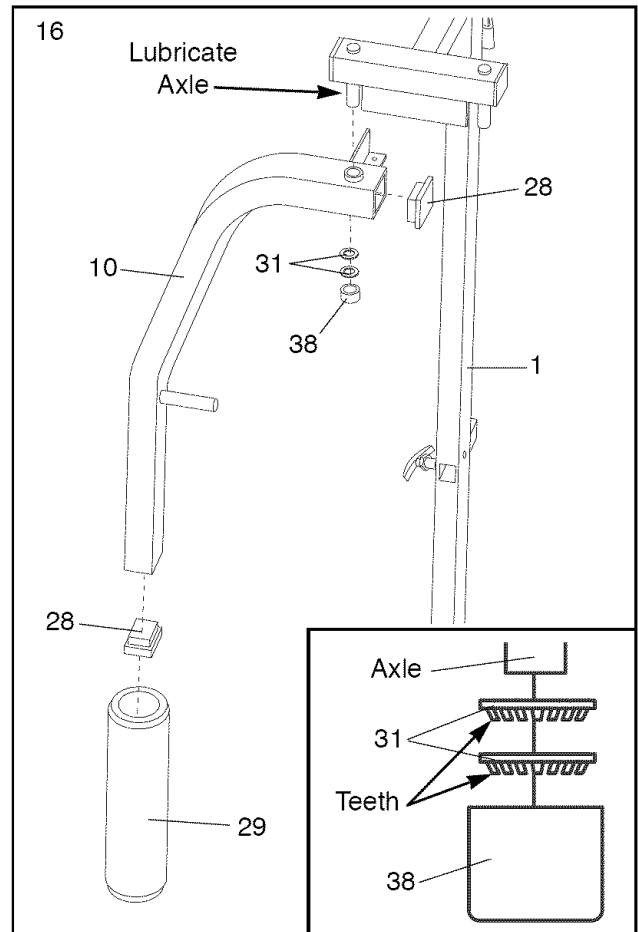

17. Press two 1 3/4" Square Inner Caps (35) into the Press Frame (8).

Lubricate the 3/8" x 9" Bolt (52). Attach the Press Frame (8) to the welded tube on the Press Upright (2) with the Bolt and a 3/8" Nylon Locknut (50). **Do not overtighten the Nylon Locknut; the Press Arm must pivot easily.**

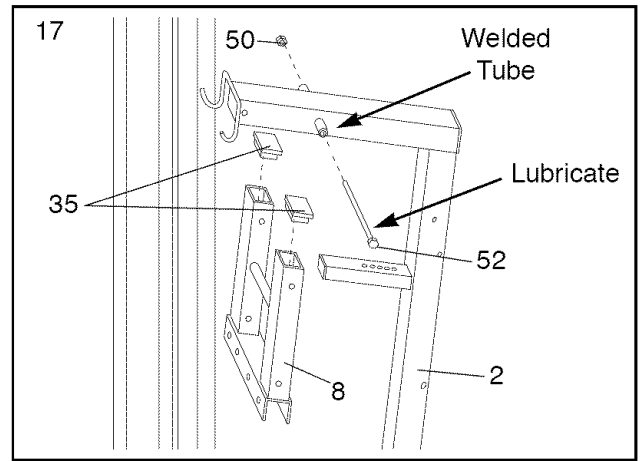

18. Press a 2" Square Inner Cap (28) into the lower end of a Press Arm (77). Press a 1" Inner Cap (76) into the indicated hole in the Press Arm.

Attach the Press Arm (77) to the bracket on the Press Frame (8) with two 5/16" x 2 3/4" Bolts (89) and two 5/16" Nylon Locknuts (64).

Repeat these steps to attach the second Press Arm (77, not shown).

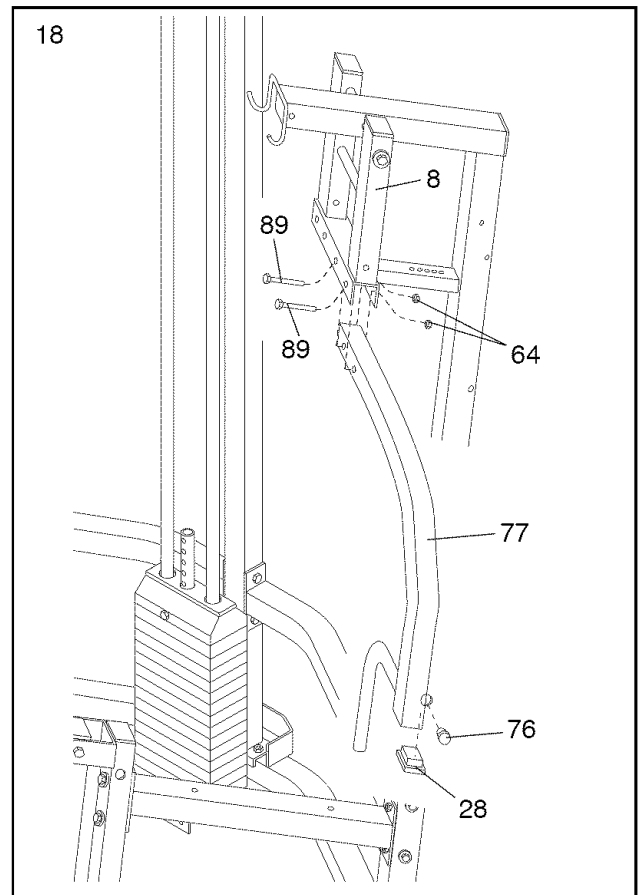

## Cable Assembly

19. Locate and open the parts bag labeled "CABLE ASSEMBLY AND PULLEYS." For Cable identification and routing during steps 19 to 49, refer to the Cable Diagram and the Cable ID Chart on pages 24 and 25.

**Important note: Although the following steps are not difficult to perform, correct cable routing is critical to the functioning of the weight system. Make sure that you wrap the cables around the pulleys exactly as shown in each step.**

Identify the Butterfly Cable (73). It is approximately 72 1/4" long, and it has a closed loop on each end. Attach the Butterfly Cable to the welded bracket on the Left Butterfly Arm (11) with a 3/8" x 1" Bolt (84) and two 3/8" Nylon Jam Nuts (63). **Note: The loop on the Cable and the two Nylon Jam Nuts must be mounted underneath the welded bracket.**

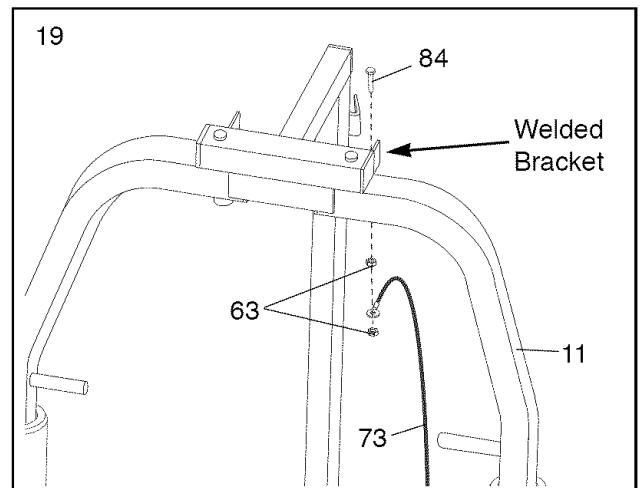

20. Wrap the Butterfly Cable (73) around a "V"-Pulley (27) in the direction shown. Attach the "V"-Pulley and a Large Cable Trap (32) to the welded bracket **on the back of the Butterfly Upright (1)** with a 3/8" x 2 1/2" Bolt (53) and a 3/8" Nylon Locknut (50). **Make sure that the Large Cable Trap is turned as shown.**

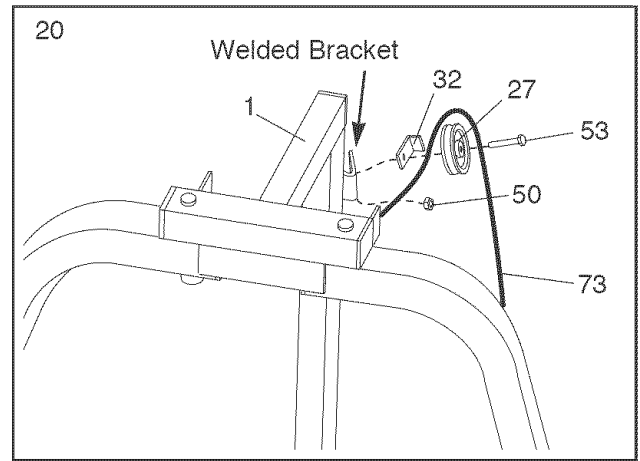

21. Remove both 3 1/2" Pulleys (24) and Cable Traps (25) from the pre-assembled Adjustable Pulley Plates (23).

Wrap the Butterfly Cable (73) around a 3 1/2" Pulley (24) in the direction shown. Attach the Pulley to the top hole in the Adjustable Pulley Plates (23) with a 3/8" x 2" Bolt (54) and a 3/8" Nylon Locknut (50). **Make sure the Cable Trap and the Adjustable Pulley Plates are oriented as shown in the drawing.**

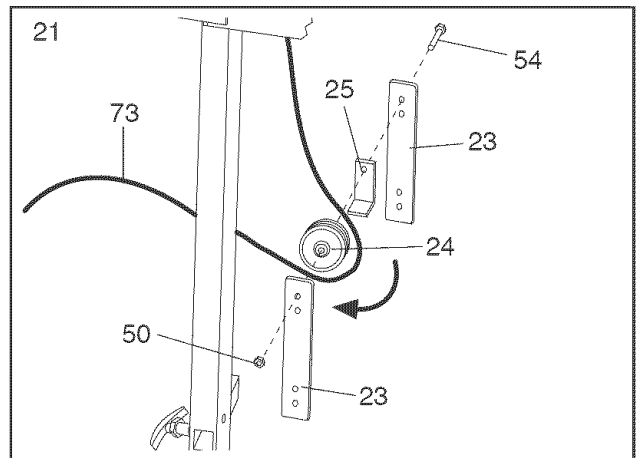

22. Wrap the Butterfly Cable (73) around a "V"-Pulley (27) in the direction shown. Attach the "V"-Pulley and a Large Cable Trap (32) to the welded bracket (not visible in the drawing) **on the back of the Butterfly Upright (1)** with a 3/8" x 2 1/2" Bolt (53) and a 3/8" Nylon Locknut (50). **Make sure that the Large Cable Trap is oriented as shown.**

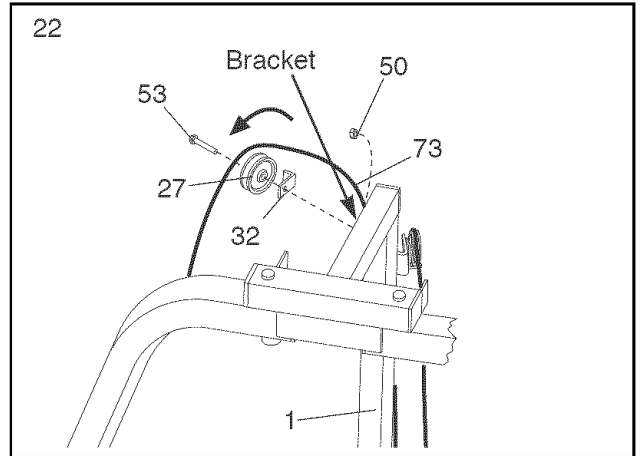

23. Attach the Butterfly Cable (73) to the welded bracket on the Right Butterfly Arm (10) with a 3/8" x 1" Bolt (84) and two 3/8" Nylon Jam Nuts (63). **Note: The loop on the Cable and the two Nylon Jam Nuts must be mounted underneath the welded bracket.**

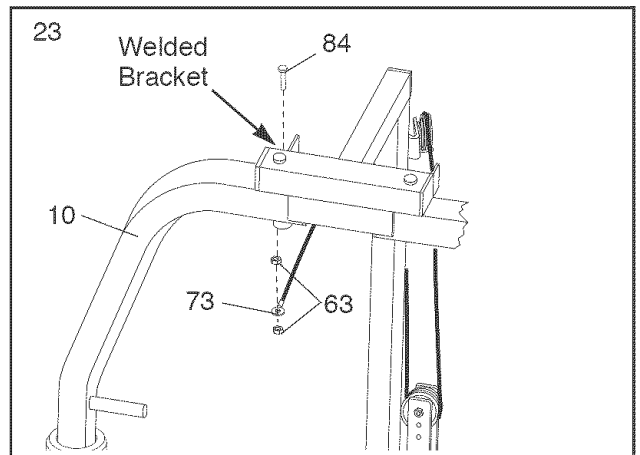

24. Identify the Weight Cable (72). It is approximately 118 1/4" long and it has a closed loop on one end and a bolt on the other.

Thread the 1/2" Plain Nut (100) onto the bolt at the end of the Weight Cable (72). Place the Long Weight Spacer (96) over the Weight Tube (17) and place the 1/2" Flat Washer (98) on top of the Long Weight Spacer. Thread the bolt at the end of the Weight Cable into the Weight Tube.

**Note: The bolt at the end of the Weight Cable is one of the means for tightening the Cables (72, 73, 74, and 75). When you have mounted all Cables, use the following procedure for tightening the Cables: Thread the bolt into the Weight Tube (17) until all Cables are tight and rest firmly in the grooves of all Pulleys. Then tighten the 1/2" Plain Nut (100) onto the 1/2" Washer (98).**

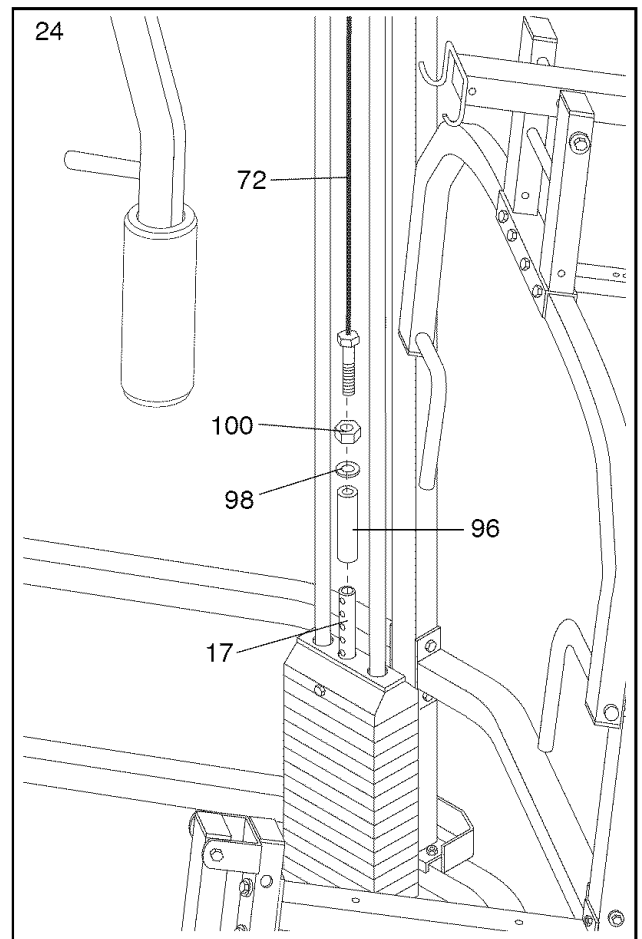

25. Route the Weight Cable (72) through the opening between the Weight Guides (15) as shown and then through the slot in the Weight Upright (9).

Route the Weight Cable (72) over a 3 1/2" Pulley (24) as shown. Attach the 3 1/2" Pulley inside the slot in the Weight Upright (9) with a 3/8" x 2 3/4" Bolt (46), two 3/8" Flat Washers (48), two 5/8" x 1/2" Spacers (102) and a 3/8" Nylon Locknut (50).

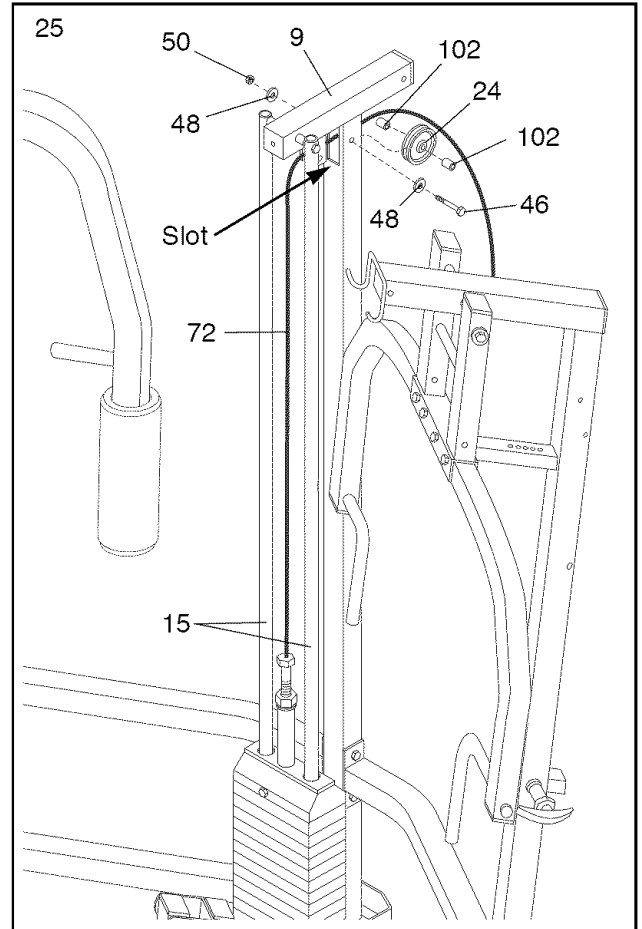

26. Place the Weight Cable (72) in the groove of a 3 1/2" Pulley (24) and push the Pulley up into the welded bracket on the Weight Upright (9). Attach the 3 1/2" Pulley inside the welded bracket on the Weight Upright (9) with a 3/8" x 1 3/4" Bolt (57) and a 3/8" Nylon Locknut (50).

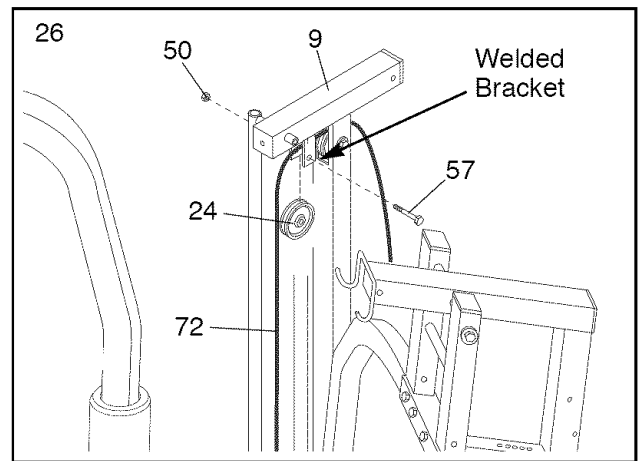

27. Remove both 3 1/2" Pulleys (24) from the pre-assembled Pulley Frame (22).

Wrap the Weight Cable (72) around a 3 1/2" Pulley (24) in the direction shown. Attach the 3 1/2" Pulley to the Pulley Frame (22) with a 3/8" x 1 3/4" Bolt (57) and a 3/8" Nylon Locknut (50). **Make sure that the Pulley Frame is turned as shown.**

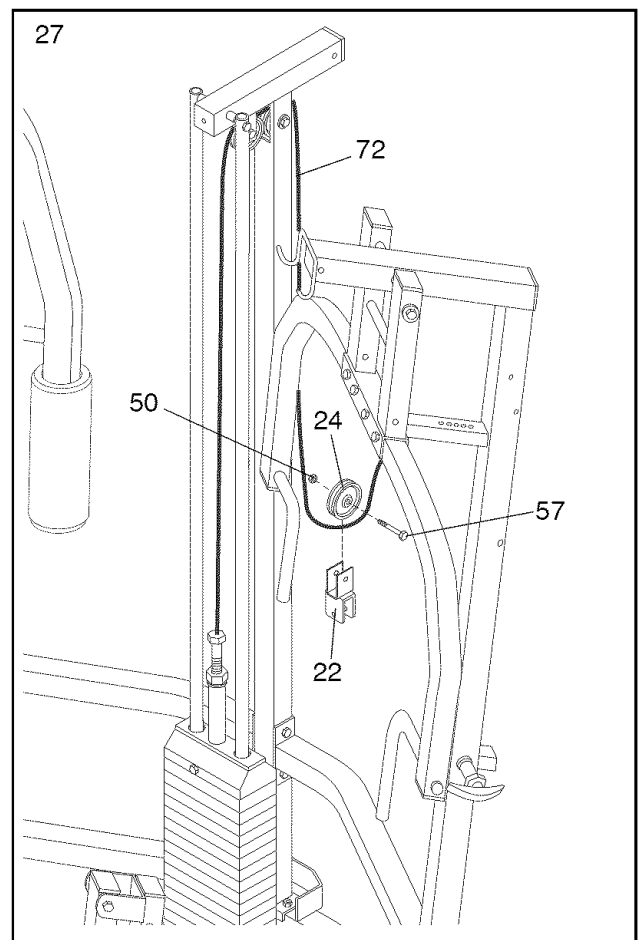

28. Attach the closed loop on the Weight Cable (72) inside the indicated slot in the Weight Upright (9) with a 3/8" x 2 3/4" Bolt (46), two 3/8" Flat Washers (48), and a 3/8" Nylon Locknut (50).

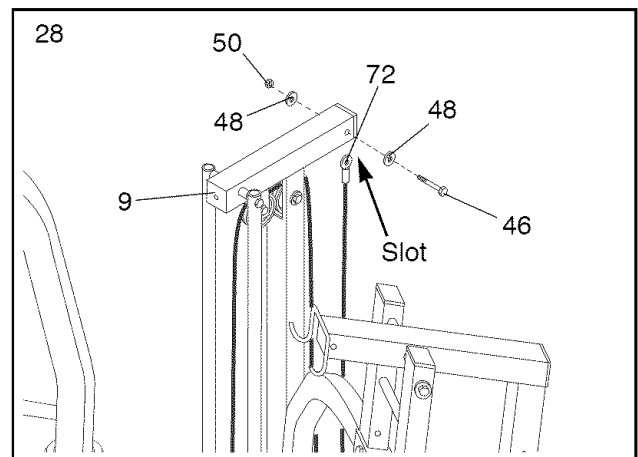

29. Identify the Ab Cable (74). It is approximately 175 1/4" long, and it has a ball on each end.

Wrap one end of the Ab Cable (74) around a 3 1/2" Pulley (24) in the direction shown. Attach the Pulley to the indicated hole in the Press Upright (2) with a 3/8" x 3 1/2" Bolt (56), a 3/8" Flat Washer (48), and a 3/8" Nylon Jam Nut (63). **Make sure that the Cable is between the Pulley and the lat bar holder.**

Route the Ab Cable (74) through the upper opening in the Press Frame (8) as shown.

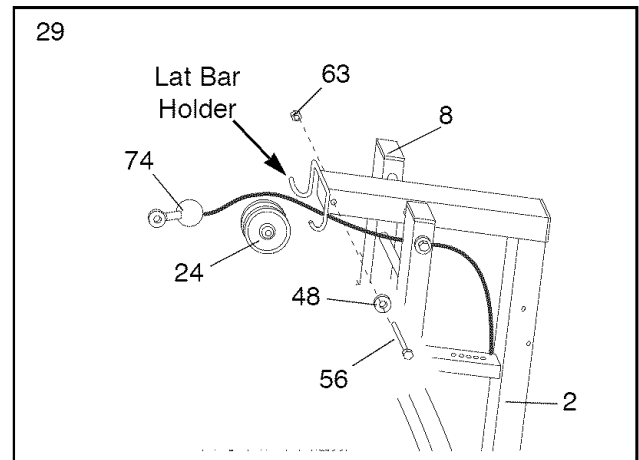

30. Wrap the Ab Cable (74) around a 3 1/2" Pulley (24) in the direction shown. Attach the Pulley and a Cable Trap (25) to the indicated hole (make sure you select the upper hole) in the Press Upright (2) with a 3/8" x 3 3/4" Bolt (59), a 3/8" Flat Washer (48), and a 3/8" Nylon Jam Nut (63). **Make sure that the Cable Trap is oriented as shown.**

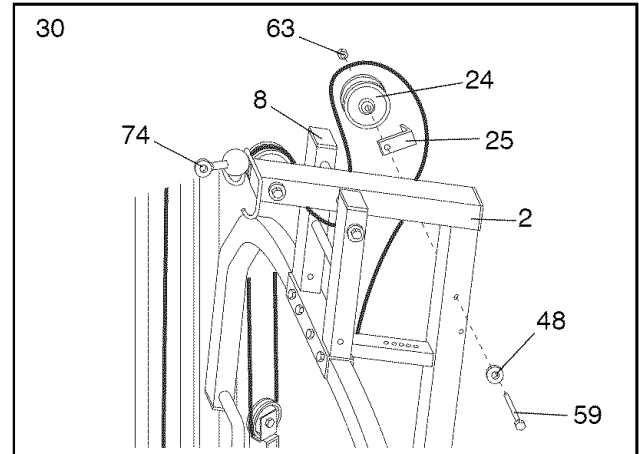

31. Route the Ab Cable (74) through the lower opening in the Press Frame (8) as shown.

Wrap the Ab Cable (74) around a 3 1/2" Pulley (24) in the direction shown. Attach the Pulley and a Cable Trap (25) to the indicated hole in the Press Frame (8) with a 3/8" x 3 1/2" Bolt (56), a 3/8" Flat Washer (48), and a 3/8" Nylon Locknut (50). **Make sure that the Cable Trap is oriented as shown.**

Route the Ab Cable (74) back through the lower opening in the Press Frame (8) as shown.

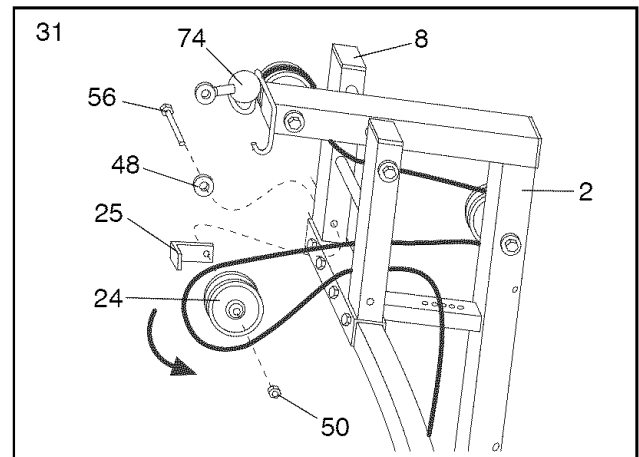

32. Wrap the Ab Cable (74) around a "V"-Pulley (27) in the direction shown. Attach the "V"-Pulley and a Large Cable Trap (32) to the indicated hole (the second hole from the end) in the tube on the Press Upright (2) with a 3/8" x 4" Bolt (60), a 3/8" Flat Washer (48), and a 3/8" Nylon Locknut (50). **Make sure that the Cable Trap is oriented as shown.**

Route the Ab Cable (74) through the lower opening in the Press Frame (8) as shown.

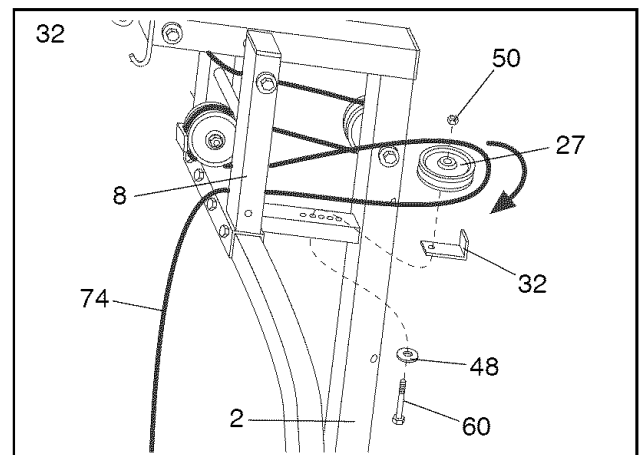

33. Wrap the Ab Cable (74) around a 3 1/2" Pulley (24) in the direction shown. Attach the Pulley and a Cable Trap (25) to the indicated hole in the Press Frame (8) with a 3/8" x 3 1/2" Bolt (56), a 3/8" Flat Washer (48), and a 3/8" Nylon Locknut (50). **Make sure that the Cable Trap is oriented as shown.**

Route the Ab Cable (74) back through the lower opening in the Press Frame (8) as shown.

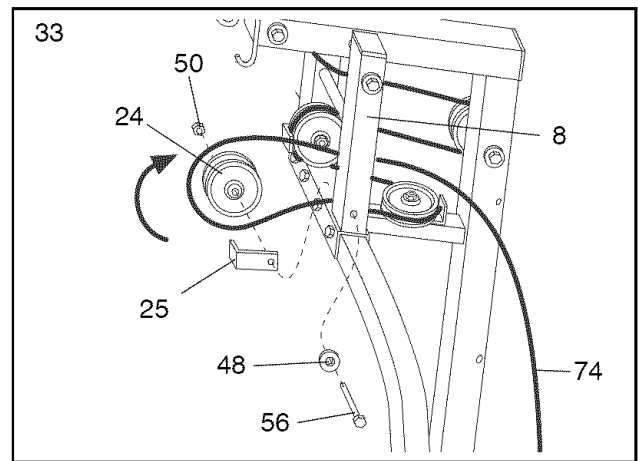

34. Wrap the Ab Cable (74) around a 3 1/2" Pulley (24) in the direction shown. Attach the Pulley and a Cable Trap (25) to the indicated hole in the Press Upright (2) with a 3/8" x 3 3/4" Bolt (59), a 3/8" Flat Washer (48) and a 3/8" Nylon Jam Nut (63). **Make sure that the Cable Trap is oriented as shown.**

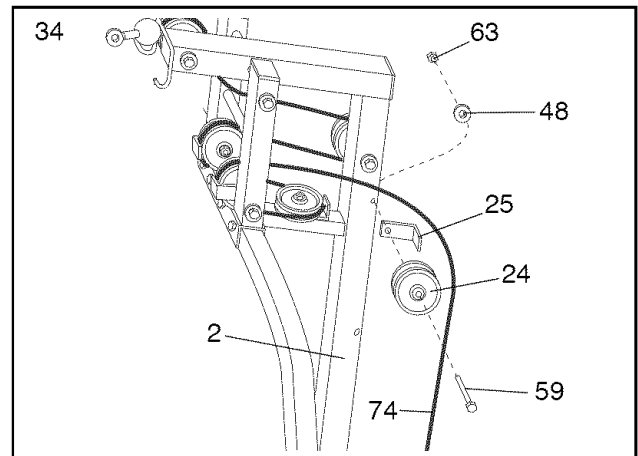

35. Remove both of the pre-assembled 3 1/2" Pulleys (24) from the Adjustable Pulley Plates (23).

Wrap the Ab Cable (74) around a 3 1/2" Pulley (24) in the direction shown. Attach the Pulley and a Cable Trap (25) to the upper hole in the Adjustable Pulley Plates (23) with a 3/8" x 2" Bolt (54) and a 3/8" Nylon Locknut (50). **Make sure that the Cable Trap and the Adjustable Pulley Plates are oriented as shown.**

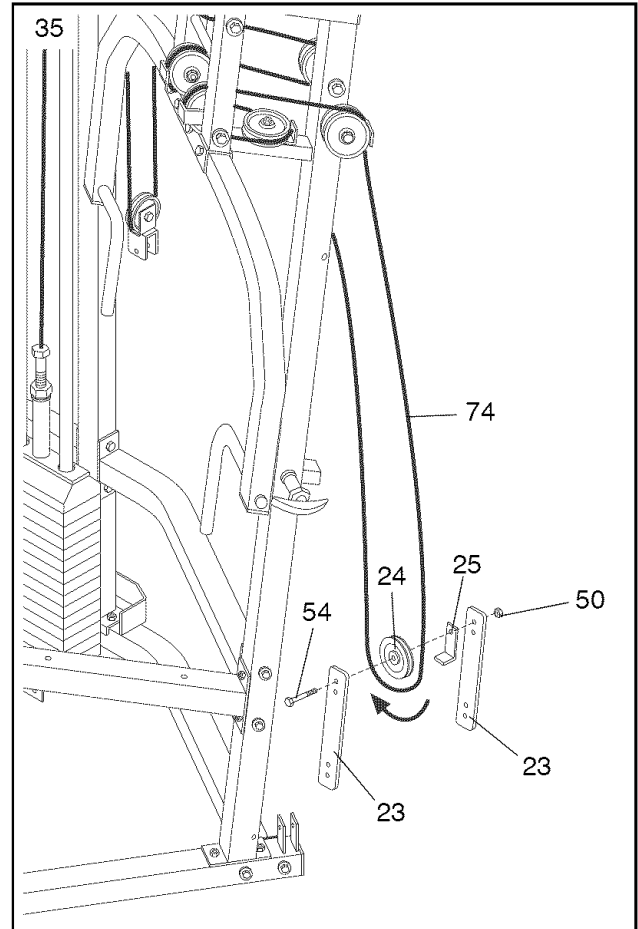



36. Wrap the Ab Cable (74) around a 3 1/2" Pulley (24) in the direction shown. Place two Pulley Covers (47) over the Pulley, so that the slots in the Pulley Covers are placed over the Cable. Attach the Pulley and the Pulley Covers to the indicated hole in the Press Upright (2) with a 3/8" x 3 3/4" Bolt (59), two 3/8" Flat Washers (48) and a 3/8" Nylon Jam Nut (63). **Make sure that the Cable is between the Pulley and the welded pin (not visible in the drawing) on the Upright.**

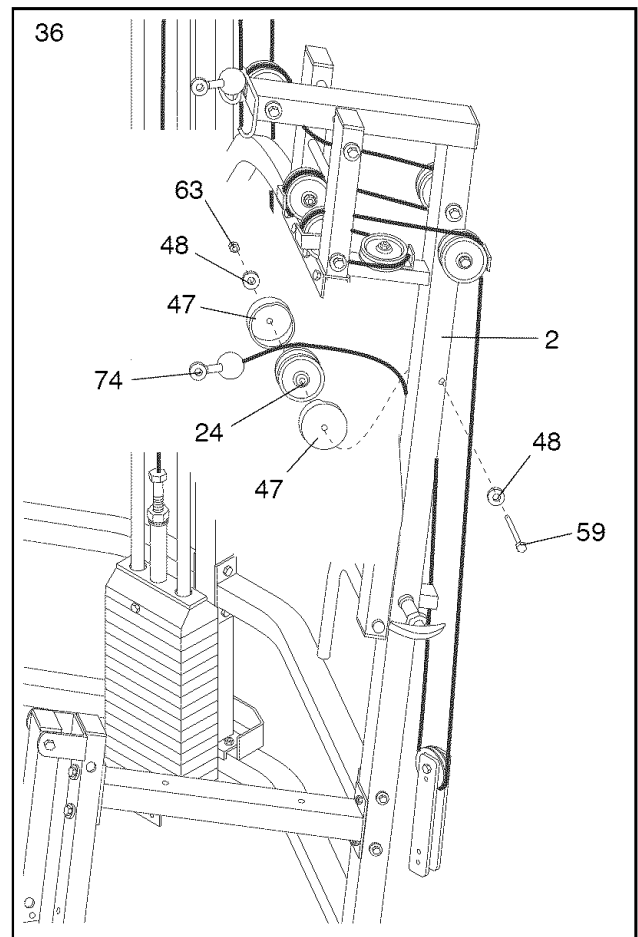

37. Identify the Low Cable (75). It is approximately 312 1/4" long, and it has a ball on one end and a closed loop on the other end.

Route the end of the Low Cable (75) with the closed loop through the cable guide on the Butterfly Base (4). Wrap the Low Cable (75) around a 3 1/2" Pulley (24) in the direction shown. Attach the Pulley and a Cable Trap (25) to the welded bracket on the Butterfly Base with a 3/8" x 2" Bolt (54) and a 3/8" Nylon Locknut (50).

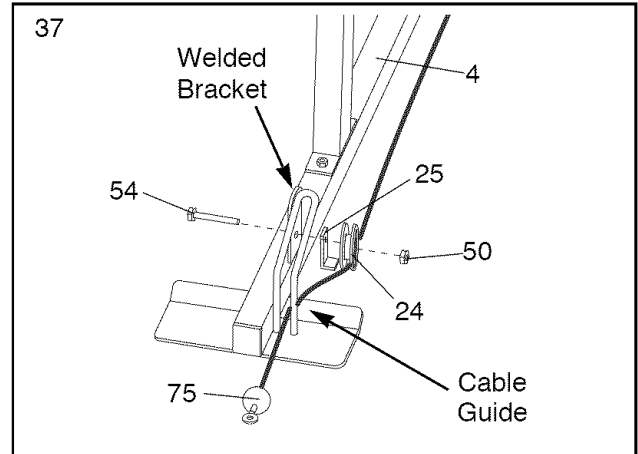

38. Wrap the Low Cable (75) around a 3 1/2" Pulley (24) in the direction shown. Attach the Pulley and a Cable Trap (25) to the indicated hole in the Butterfly Upright (1) with a 3/8" x 3 3/4" Bolt (59), a 3/8" Flat Washer (48) and a 3/8" Nylon Jam Nut (63). **Make sure that the Cable Trap is oriented as shown.**

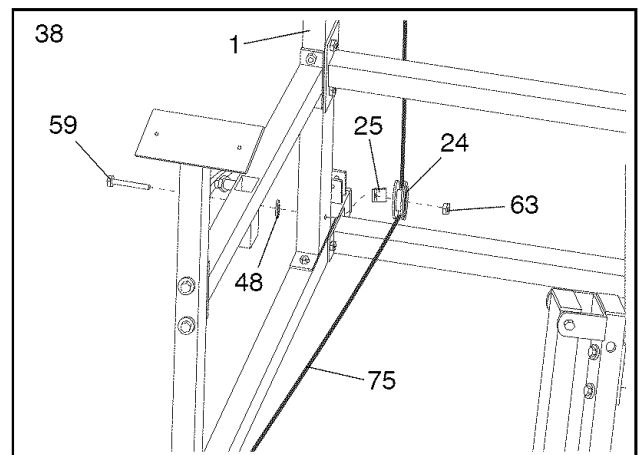

39. Wrap the Low Cable (75) around a 3 1/2" Pulley (24) in the direction shown. Attach the Pulley and a Cable Trap (25) to the second hole from the bottom of the Adjustable Pulley Plates (23) with a 3/8" x 2" Bolt (54) and a 3/8" Nylon Locknut (50). **Make sure the Cable Trap is oriented as shown.**

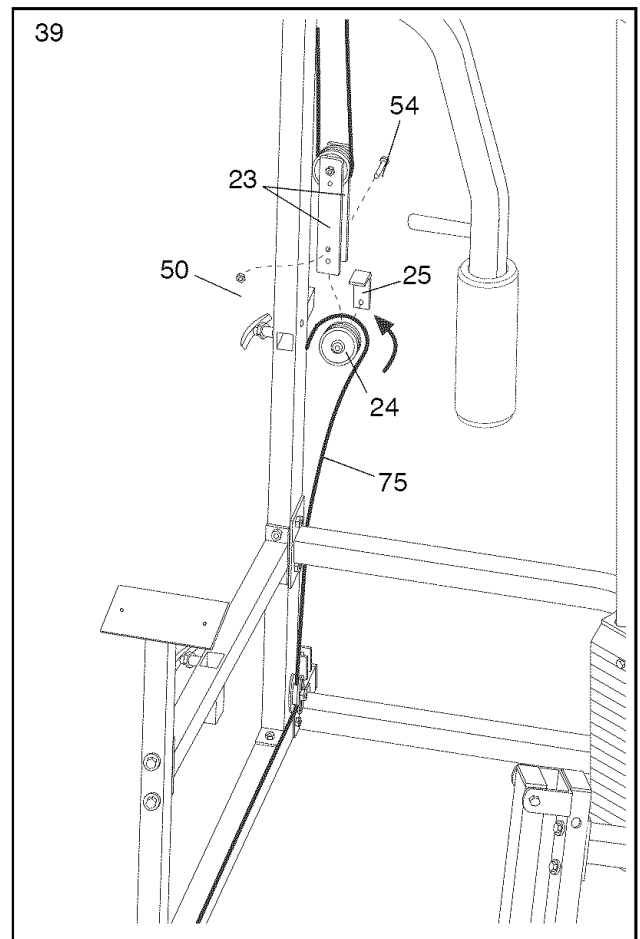

40. Wrap the Low Cable (75) around a 3 1/2" Pulley (24) in the direction shown. Attach the Pulley to the welded bracket on the Butterfly Base (4) with a 3/8" x 1 3/4" Bolt (57) and a 3/8" Nylon Locknut (50).

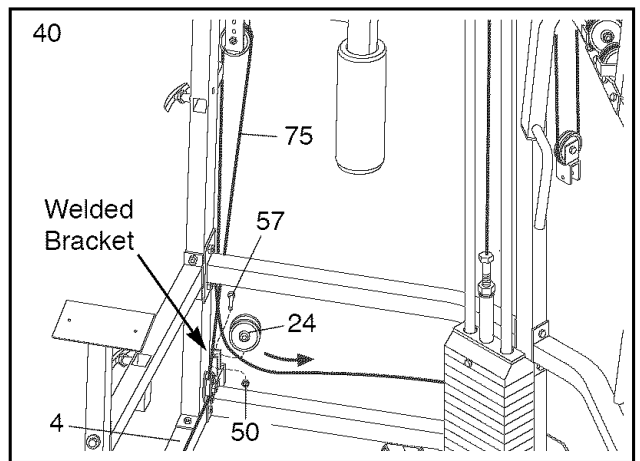

41. Note: For clarity, the weight stack is not shown.

Wrap the Low Cable (75) around a 3 1/2" Pulley (24) in the direction shown. Attach the Pulley and a Cable Trap (25) to the welded bracket on the Weight Base (5) with a 3/8" x 2" Bolt (54) and a 3/8" Nylon Locknut (50). **Make sure the Cable Trap is oriented as shown.**

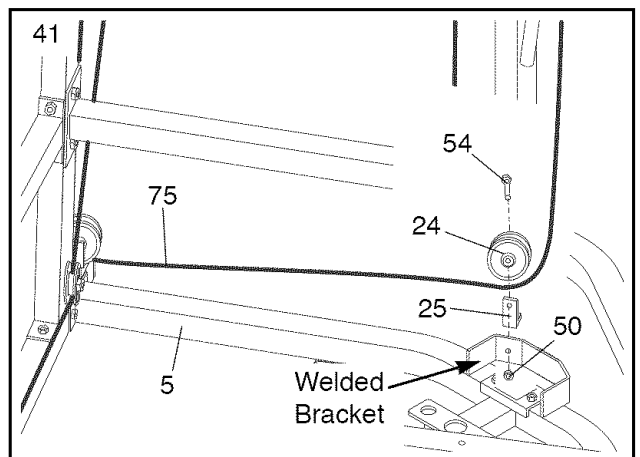

42. Wrap the Low Cable (75) around a 3 1/2" Pulley (24) in the direction shown. Attach the Pulley to the lower half of the Pulley Frame (22) with a 3/8" x 1 3/4" Bolt (57) and a 3/8" Nylon Locknut (50).

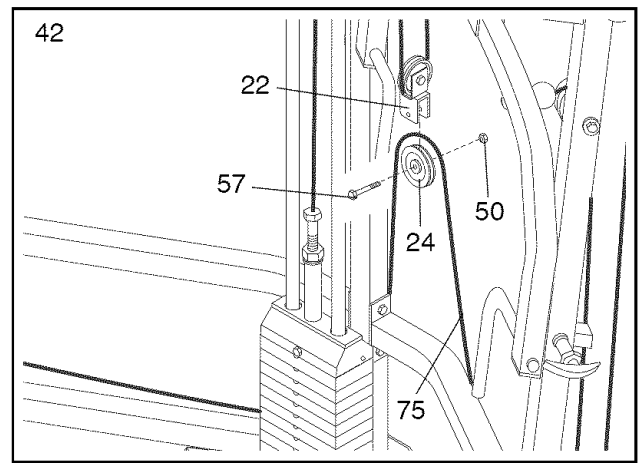

43. Wrap the Low Cable (75) around a 3 1/2" Pulley (24) in the direction shown. Attach the Pulley and a Cable Trap (25) to the welded bracket on the Weight Base (5) with a 3/8" x 2" Bolt (54) and a 3/8" Nylon Locknut (50). **Make sure the Cable Trap is oriented as shown.**

Route the Low Cable (75) through the welded bracket on the Press Base (6) as shown.

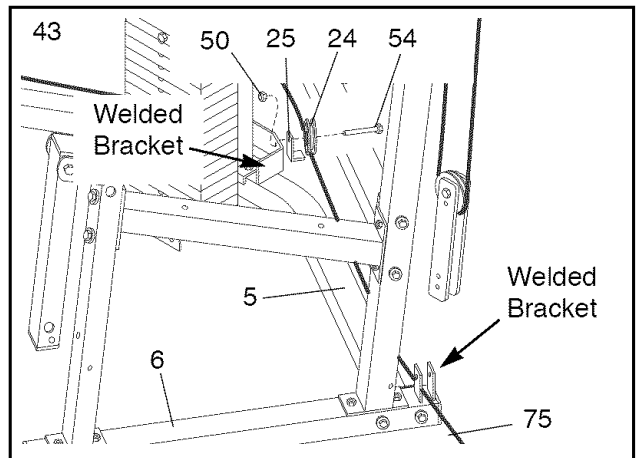

44. Wrap the Low Cable (75) around a 3 1/2" Pulley (24) in the direction shown. Attach the Pulley to the welded bracket on the Press Base (6) with a 3/8" x 1 3/4" Bolt (57) and a 3/8" Nylon Locknut (50).

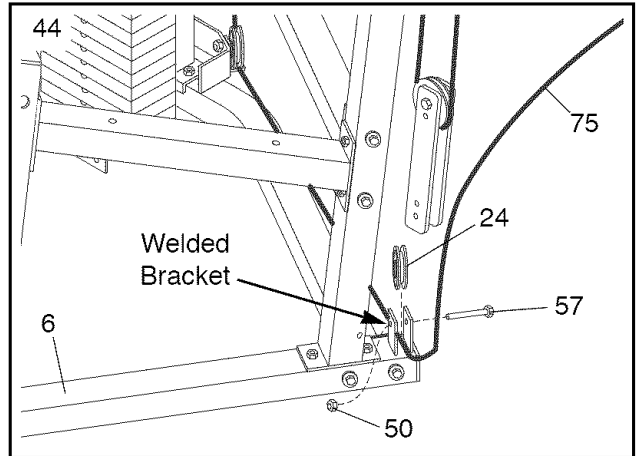

45. Wrap the Low Cable (75) around a 3 1/2" Pulley (24) in the direction shown. Attach the Pulley and a Cable Trap (25) to the second hole from the bottom of the Adjustable Pulley Plates (23) with a 3/8" x 2" Bolt (54) and a 3/8" Nylon Locknut (50). **Make sure the Cable Trap is oriented as shown.**

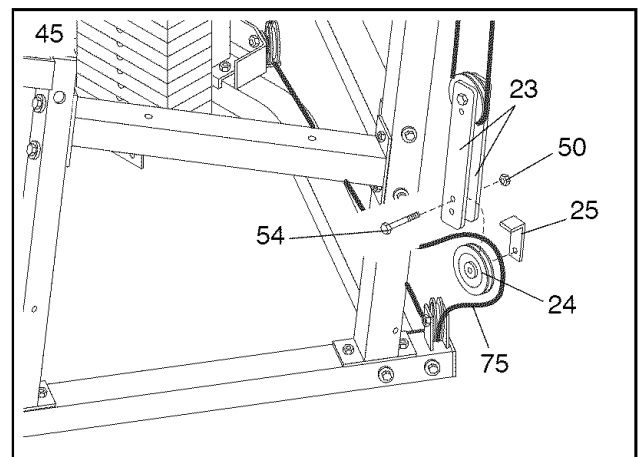

46. Wrap the Low Cable (75) around a 3 1/2" Pulley (24) in the direction shown. Attach the Pulley and a Cable Trap (25) to the indicated hole in the Press Upright (2) with a 3/8" x 3 3/4" Bolt (59), a 3/8" Flat Washer (48), and a 3/8" Nylon Jam nut (63). **Make sure that the Cable Trap is oriented as shown.**

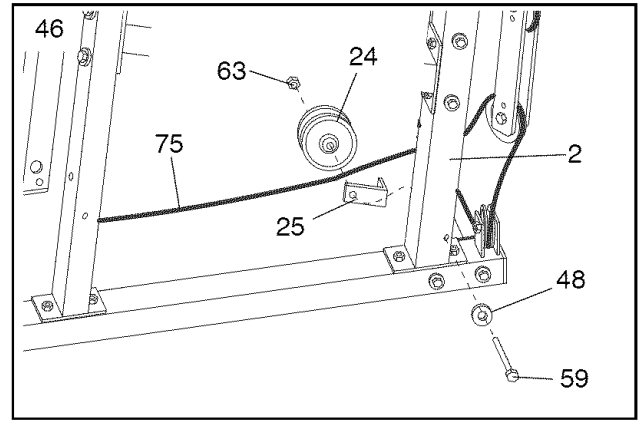

47. Route the Low Cable (75) under a 3 1/2" Pulley (24) as shown. Attach the Pulley and a Cable Trap (25) to the indicated hole in the Press Front Leg (20) with a 3/8" x 3 3/4" Bolt (59), a 3/8" Flat Washer (48), and a 3/8" Nylon Jam nut (63). **Make sure that the Cable Trap is oriented as shown.**

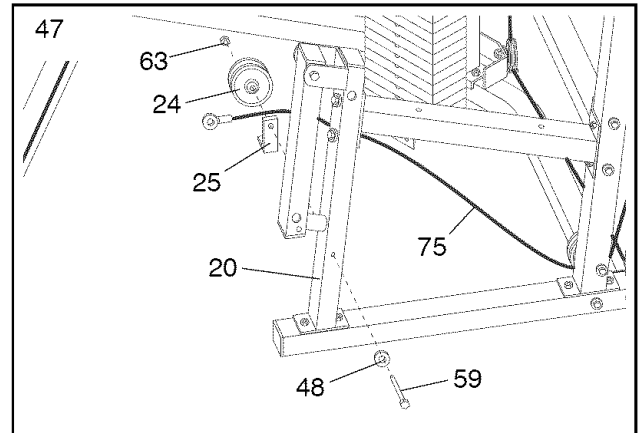

48. Attach the closed loop at the end of the Low Cable (75) to the indicated hole in the Leg Lever (41) with a 3/8" x 2 3/4" Bolt (46), two 3/8" Flat Washers (48) and a 3/8" Nylon Locknut (50).

**Go to step 24 and follow the instructions for tightening the Cables.**

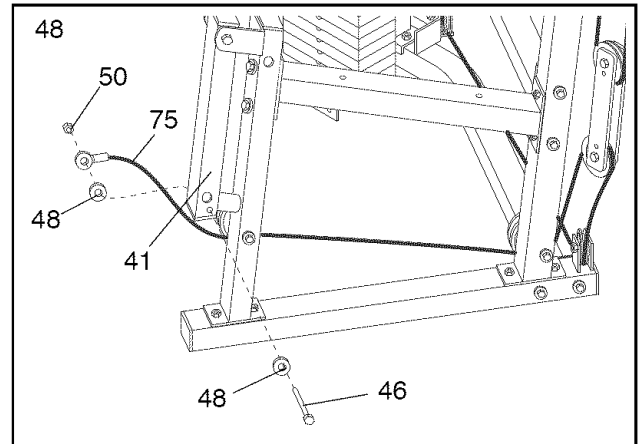

## Seat Assembly

49. Press two 1" x 2" Inner Caps (83) and a 1 1/4" Square Inner Cap (82) into the Seat Adjustment Frame (90).

Insert a 1/4" x 1 1/2" Carriage Bolt (101) into the center hole in a Seat Plate (65). Attach the Seat Plate to one of the Seats (13) with two 1/4" x 3/4" Bolts (49).

Turn the Seat Adjustment Frame (90) so the holes in the vertical tube are on the side shown. Insert the end of the 1/4" x 1 1/2" Carriage Bolt (101) into the indicated hole in the Seat Adjustment Frame and secure it with a 1/4" Flat Washer (71) and a 1/4" Nylon Locknut (68). Attach the narrow end of the Seat (13) with a 1/4" x 1 1/2" Screw (103) and a 1/4" Flat Washer (71).

Pull the indicated Adjustment Handle (85) and insert the vertical tube on the Seat Adjustment Frame (90) into the indicated hole in the Butterfly Seat Frame (14). Release the Adjustment Handle and let the tip snap into one of the holes in the Seat Adjustment Frame.

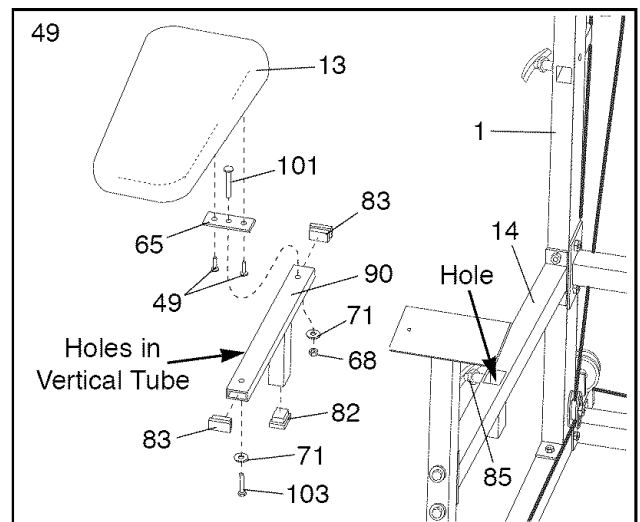

50. Press two 1" x 2" Inner Caps (83) and a 1 1/4" Square Inner Cap (82) into a Backrest Adjustment Frame (70). Orient the Backrest Adjustment Frame so the holes in the horizontal tube are on the side shown.

Identify the Butterfly Backrest (12). It has only two holes in the back. Attach the Butterfly Backrest to the Backrest Adjustment Frame (70) with two 1/4" x 1 1/2" Screws (103) and two 1/4" Flat Washers (71).

Insert the tube on the Backrest Adjustment Frame (70) into the indicated slot in the Butterfly Upright (1) and secure it with the Adjustment Handle (85).

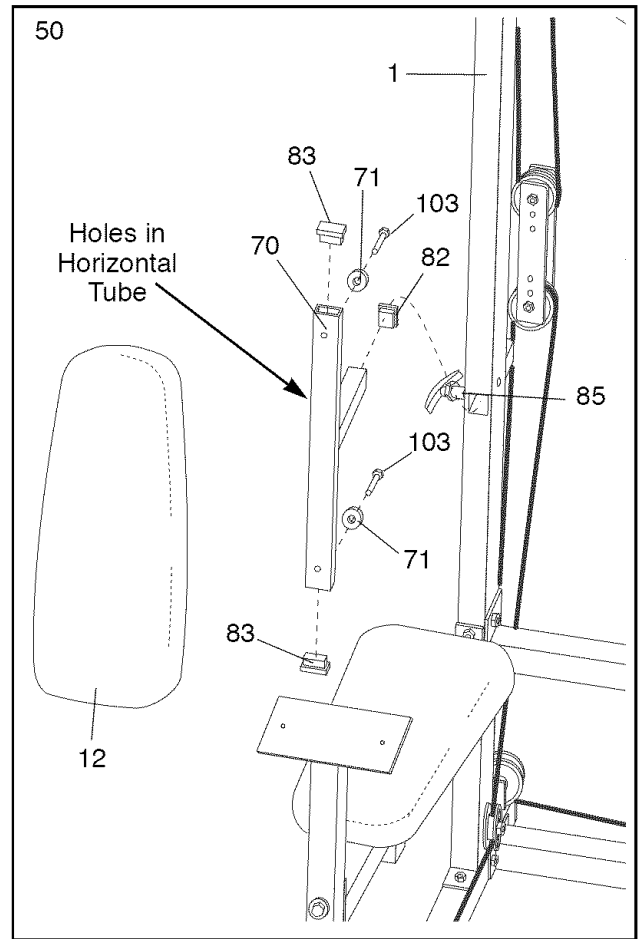

51. Press two 1" x 2" Inner Caps (83) and a 1 1/4" Square Inner Cap (82) into the other Backrest Adjustment Frame (70). Orient the Backrest Adjustment Frame so the holes in the horizontal tube are on the side shown.

Insert a 1/4" x 1 1/2" Carriage Bolt (101) into the center hole in a Seat Plate (65). Attach the Seat Plate to the Press Backrest (99) with two 1/4" x 3/4" Bolts (49).

Insert the end of the 1/4" x 1 1/2" Carriage Bolt (101) into the indicated hole in the Backrest Adjustment Frame (70) and secure it with a 1/4" Flat Washer (71) and a 1/4" Nylon Locknut (68). Secure the other end of the Backrest with a 1/4" x 1 1/2" Screw (103) and a 1/4" Flat Washer (71).

Insert the tube on the Backrest Adjustment Frame (70) into the indicated slot in the Press Upright (2) and secure it with the Adjustment Handle (85).

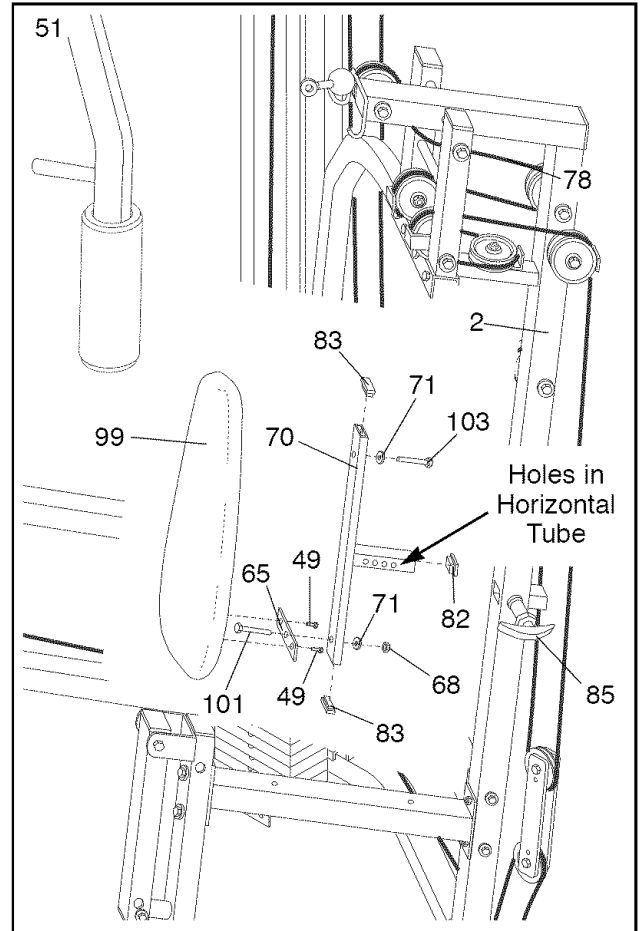

52. Insert a 1/4" x 2 1/2" Carriage Bolt (45) into the center hole in a Seat Plate (65). Attach the Seat Plate to a Seat (13) with two 1/4" x 3/4" Bolts (49). Insert the 1/4" x 2 1/2" Carriage Bolt (45) into the indicated hole in the Press Seat Frame (7) and secure it with a 1/4" Flat Washer (71) and a 1/4" Nylon Locknut (68).

Secure the other end of the Seat (13) with a 1/4" x 2 1/2" Bolt (79) and a 1/4" Flat Washer (71).

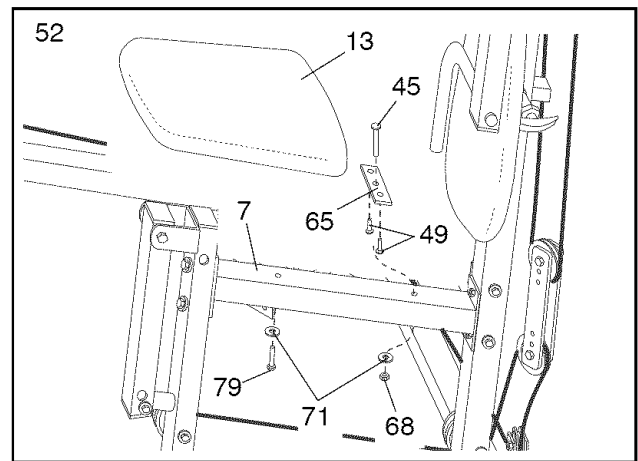

53. Attach the Curl Pad (91) to the welded plate on the Butterfly Front Leg (3) with two 1/4" x 3/4" Bolts (49). **Make sure that the flat edge of the Curl Pad is facing as shown..**

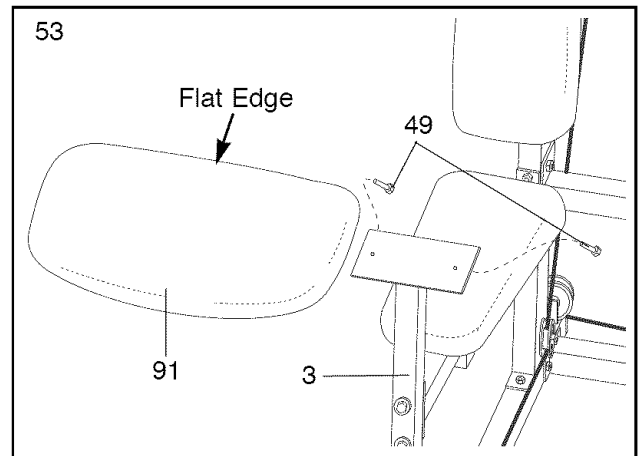

54. Remove the three preassembled 1/4" x 5/8" Screws (95) from the Shroud (34). Attach the Shroud to the indicated bracket on the Weight Base (5) with two 1/4" x 5/8" Screws.

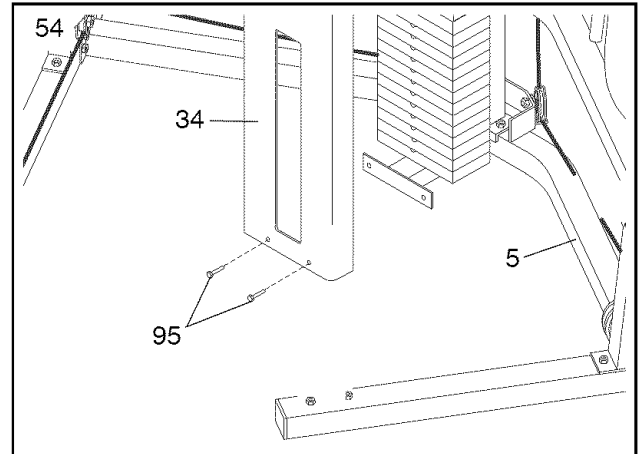

55. Attach the Shroud (34) to the top of the Weight Upright (9) with a 1/4" x 5/8" Screw (95).

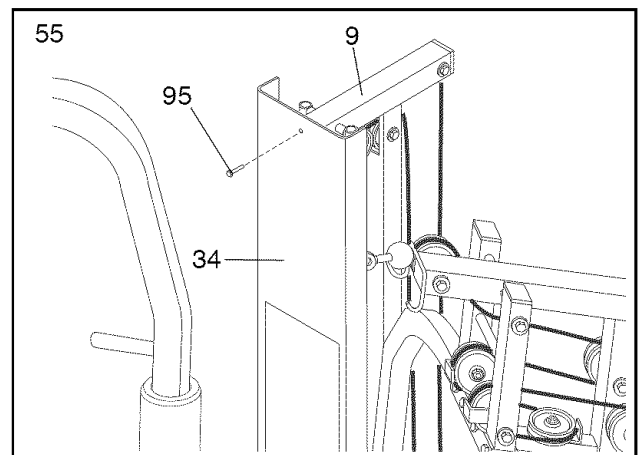

56. Press two 3/4" Round Inner Caps (43) into each of the Pad Tubes (42).

Insert one Pad Tube (42) into the indicated hole in the Press Front Leg (20). Slide a Foam Pad (30) onto each end of the Pad Tube.

Insert the other Pad Tube (42) into the indicated hole in the Leg Lever (41). Slide a Foam Pad (30) onto each end of the Pad Tube.

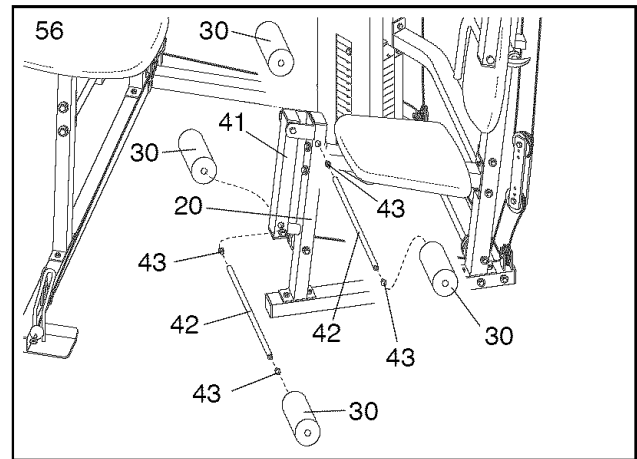

57. Make sure that all parts have been properly tightened. The use of the remaining parts will be explained in ADJUSTMENT, beginning on page 26 of this manual. Before using the home gym, pull each cable a few times to make sure that the cables move smoothly over the pulleys. If one of the cables does not move smoothly, find and correct the problem. **IMPORTANT: If the cables are not properly installed, they may be damaged when heavy weight is used. If there is any slack in the cables, you will need to remove the slack by tightening the cables. See TROUBLE-SHOOTING AND MAINTENANCE on page 27.**

## Weight Resistance Chart

The chart below shows the approximate weight resistance at each exercise station. "Top" refers to the 6 lb. top weight; the other numbers refer to the 10 lb. weight plates. **Note: The actual resistance at each station may vary due to differences in individual weight plates as well as friction between the cables, pulleys, and weight guides.**

Weight Plates	Leg Lever (lbs.)	High Pulley (lbs.)	Arm Press (lbs.)	Ab Pulley (lbs.)	Low Pulley (lbs.)	Butterfly Arms (lbs.)
Top	19	12	14	9	7	17
1	31	23	27	19	18	30
2	43	34	39	30	30	42
3	55	46	51	41	41	55
4	68	57	64	51	52	68
5	81	69	76	62	63	80
6	92	80	88	73	75	93
7	105	92	100	83	86	105
8	117	103	113	94	97	118
9	129	115	125	105	109	131
10	141	126	137	115	120	143
11	154	138	149	126	131	156
12	166	149	162	137	143	169
13	178	161	174	147	154	181
14	190	172	186	158	165	194

# Cable Diagrams

The Cable Diagrams below and on the next page show the proper routing of the Butterfly Cable (73), the Ab Cable (74), the Low Cable (75), and the Weight Cable (72). The numbers show the correct route for each Cable. **Make sure that the Cables are routed correctly, that the pulleys move smoothly, and that the cable traps do not touch or bind the Cables. Incorrect cable routing can damage the weight system.**

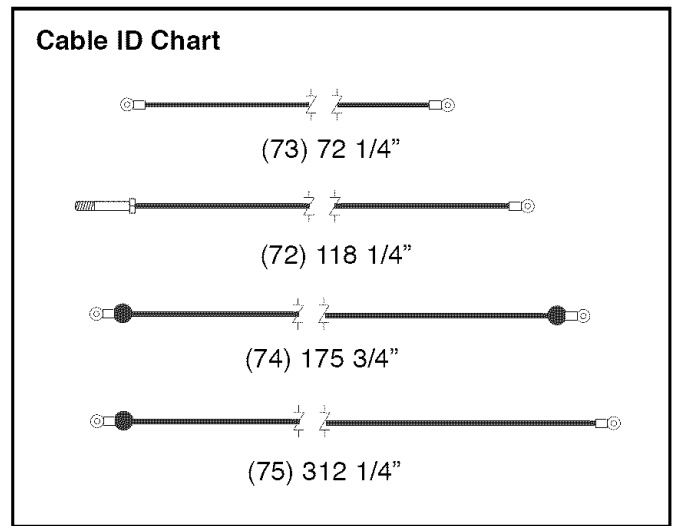
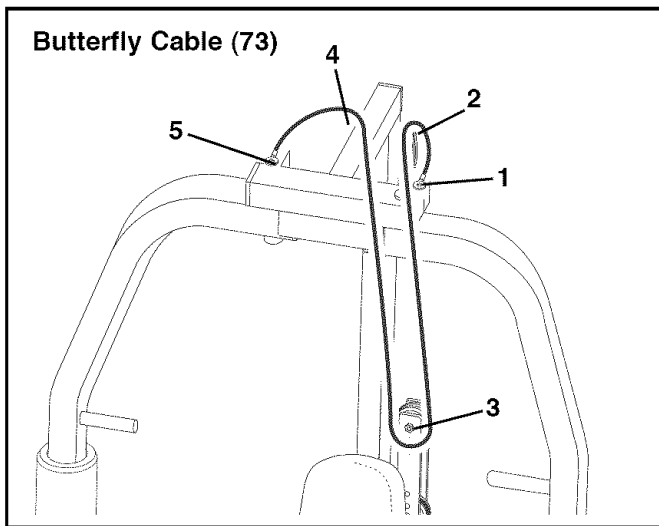
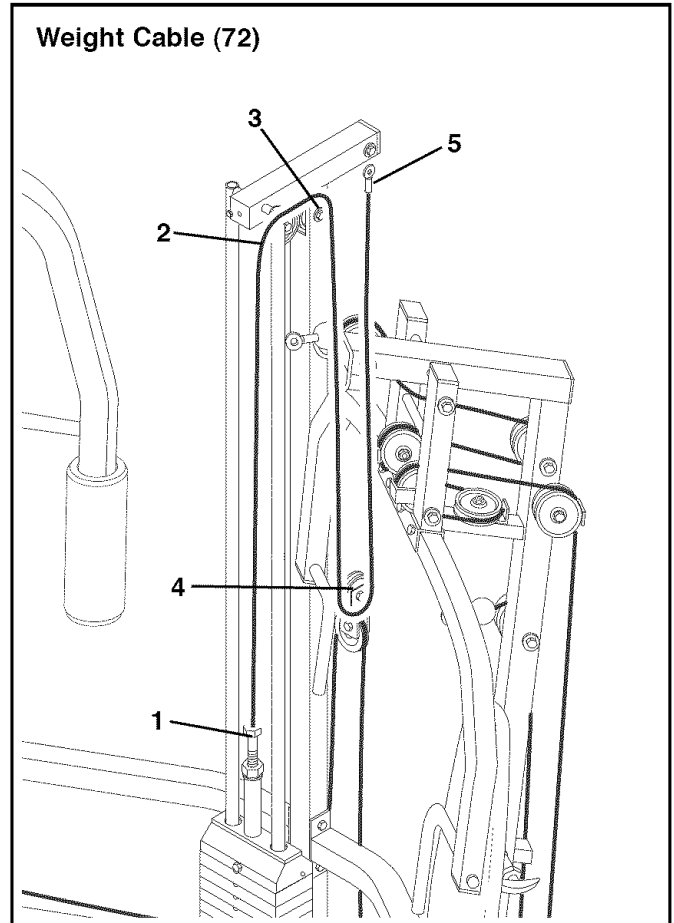
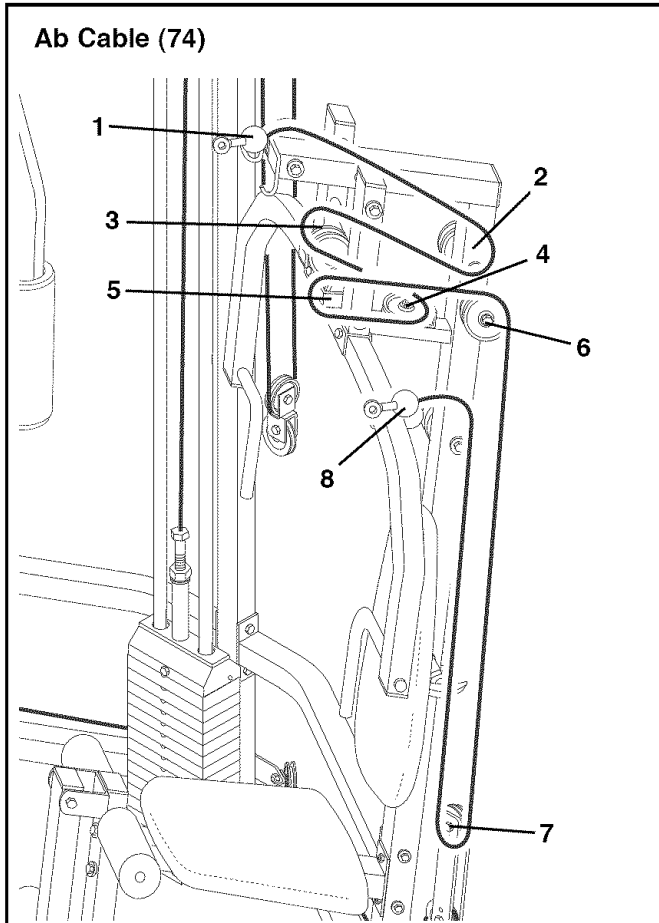



Low Cable (75)

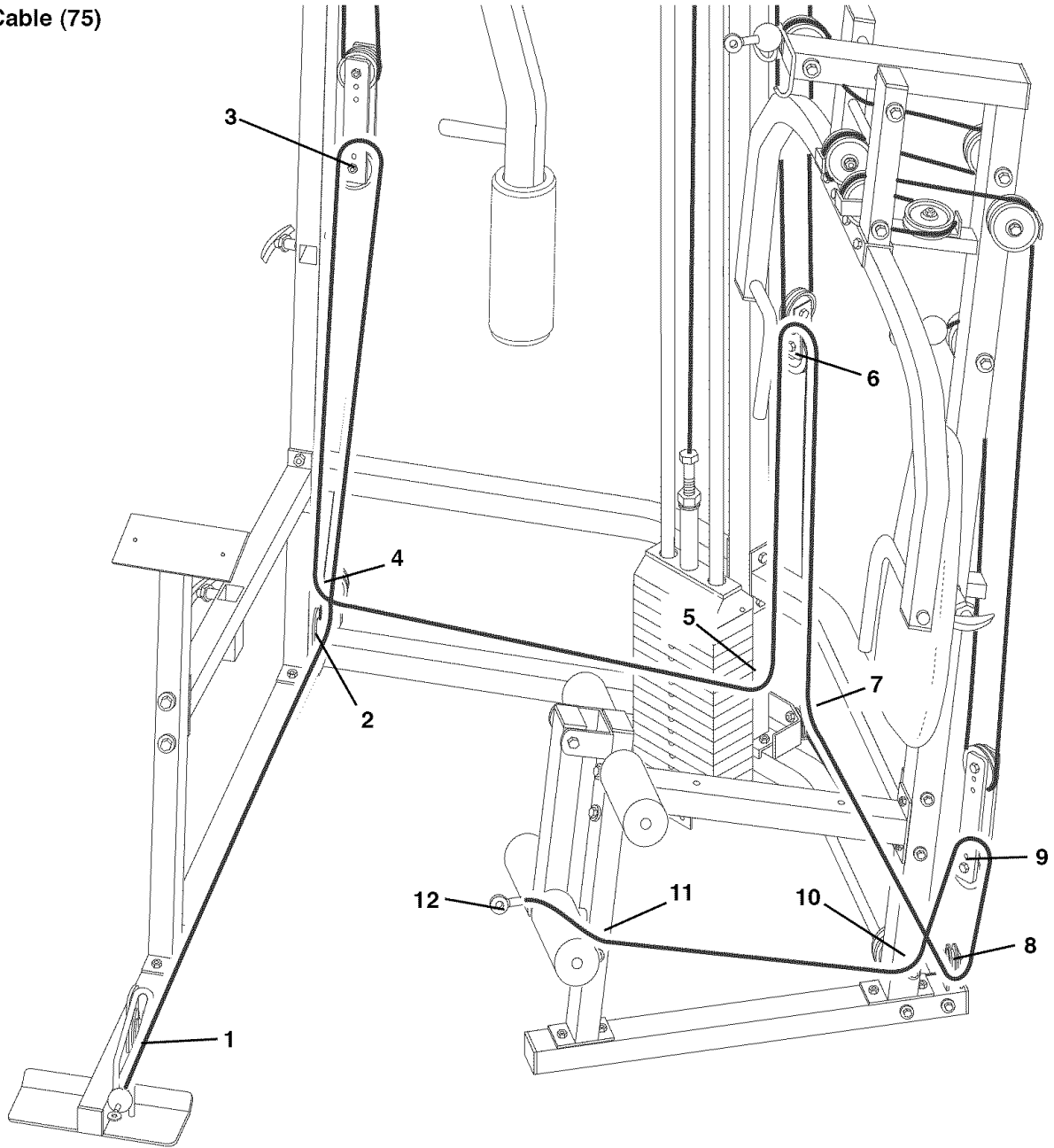

# Adjustment

The instructions below describe how each part of the home gym can be adjusted. Refer to the decal on the shroud to see how the home gym should be set up for each exercise. **IMPORTANT: When using an attachment, make sure it is in the correct starting position for the exercise to be performed. If there is any slack in the cables or chain as an exercise is performed, the effectiveness of the exercise will be reduced.**

## Attaching the Lat Bar, Row Bar, Nylon Strap or Ab Strap to the Low Pulley Station, the High Pulley Station, or the Ab Pulley Station.

Attach the Lat Bar (61) to the Low Cable (75) with a Cable Clip (69). For some exercises, the Chain (67) should be attached between the Lat Bar and the Low Cable with two Cable Clips. **Adjust the length of the Chain between the Lat Bar and the Low Cable so the Lat Bar is in the correct starting position for the exercise to be performed.**

The Row Bar (44), Nylon Strap (58), or Ab Strap (81) can be attached in the same manner.

Use the same method for attaching any of the attachments to the Ab Cable (74, not shown) at the High Pulley Station or the Ab Pulley Station.

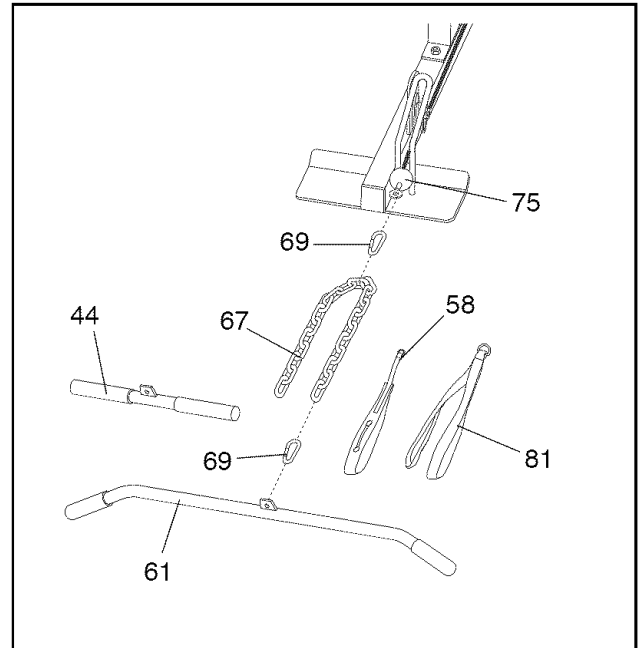

## Adjusting the Butterfly Backrest, Butterfly Seat, or Press Backrest

To adjust the Press Backrest (99), pull the Adjustment Handle (85) and slide the Backrest in or out as needed. Release the Adjustment Handle and let the tip snap into one of the holes in the Adjustment Frame. Adjust the Butterfly Seat (13, not shown) in the same manner.

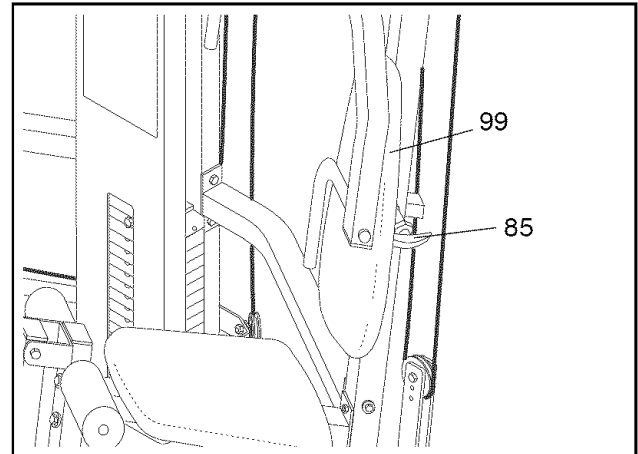

## Changing the Weight Setting

To change the setting of the weight stack, insert a Weight Pin (19) under the desired Weight (21). Make sure you insert the Weight Pin as far as it will go. **Note: Due to the cables and pulleys, the amount of resistance at each exercise station may vary from the weight setting. Use the WEIGHT RESISTANCE CHART on page 27 to find the approximate amount of resistance at each weight station.**

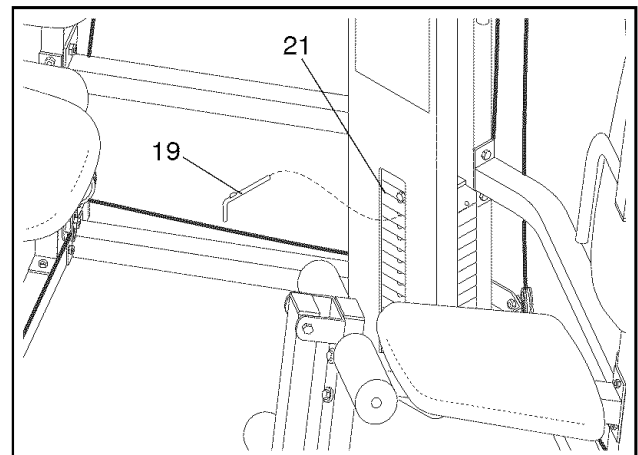

# Trouble-shooting and Maintenance

Inspect and tighten all parts each time you use the home gym. Replace any worn parts immediately. The home gym can be cleaned using a damp cloth and mild non-abrasive detergent. Do not use solvents.

## Tightening the Cables

Woven cable, the type of cable used on the home gym, can stretch slightly when it is first used. If there is slack in the Cables before resistance is felt, the Cables should be tightened.

Slack can be removed from the cables in several ways:

Remove the 3/8" x 4" Bolt (60), the 3/8" Flat Washer (48), the Large Cable Trap (32), the "V"-Pulley (27) and the 3/8" Nylon Locknut (50) from the Press Frame (8). Move the Pulley and the Cable Trap to a hole that is closer to the Press Upright (2). This will tighten the cable. Reattach the "V"-Pulley assembly, the Bolt and the Nylon Locknut. **Make sure that the Cable Trap and Cable remain oriented as shown.**

The Adjustable Pulley Plates (23) have several sets of adjustment holes. By moving one or both pulleys to a different set of holes, you will tighten the cables.

To move one Pulley, remove the 3/8" Nylon Locknut (50) and the 3/8" x 2" Bolt (54). Remove the Cable Trap (25) and the Pulley (24) from the Adjustable Pulley Frame (23). Reattach the Pulley and the Cable Trap to the appropriate adjustment hole in the Pulley Frame. **Note: Begin by moving one Pulley to the second adjustment hole. If the Cables are still too loose, move the same Pulley to the third hole. If additional adjustment is needed, move the second Pulley until the Cables are tight.**

**Note: For clarity, the Shroud is not shown. The Shroud does not have to be removed to tighten the Cables.**

The bolt at the end of the Weight Cable (72) is one of the means for tightening the Cables. Use the following procedure for tightening the Cables: Loosen the 1/2" Plain Nut (100). Thread the bolt at the end of the Weight Cable into the Weight Tube (17) until all Cables are tight and rest firmly in the grooves of all Pulleys. Then tighten the 1/2" Plain Nut (100) onto the 1/2" Washer (98).

**Note: If a Cable tends to slip off the Pulleys often, the Cable may have become twisted. Remove the Cable and re-install it.**

If the Cables need to be replaced, see ORDERING REPLACEMENT PARTS on the back cover of this manual.

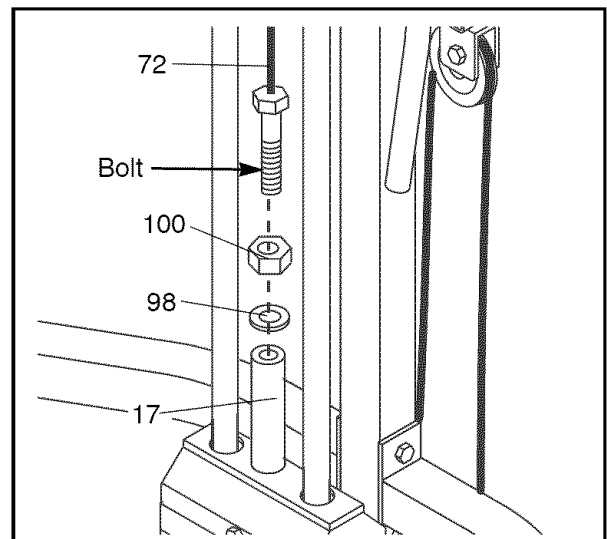
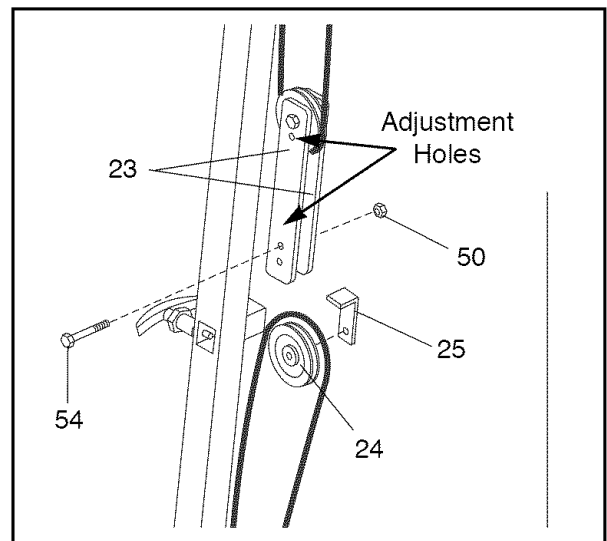
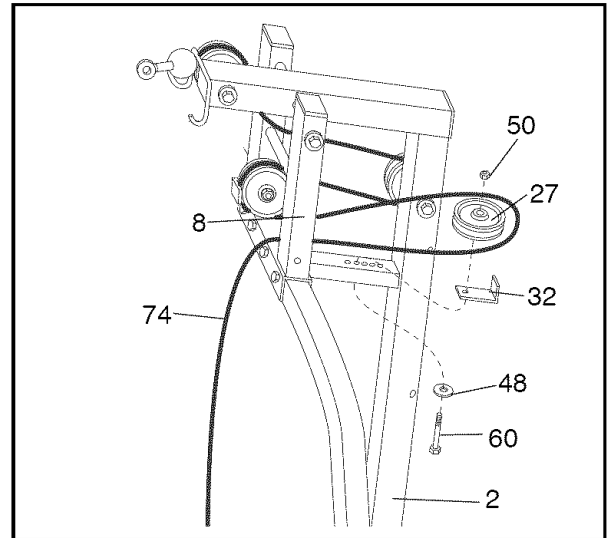

# Part Identification Chart—Model No. NTSY73690

R0100A

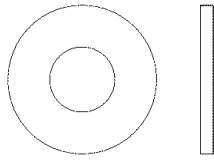

5/16" Washer (36)

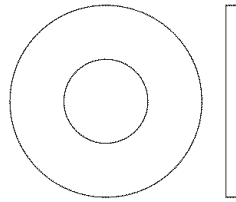

3/8" Flat Washer (48)

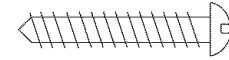

1" Tap Screw (80)

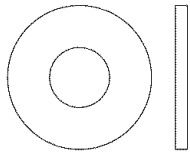

1/4" Flat Washer (71)

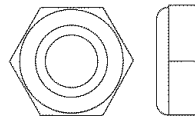

3/8" Nylon Jamnut (63)

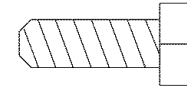

1/4" x 3/4" Bolt (49)

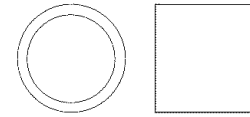

5/8 x 1/2 Spacer (102)

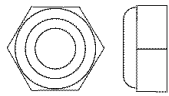

1/4" Nylon Locknut (68)

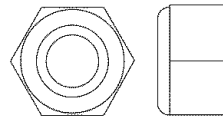

3/8" Nylon Locknut (50)

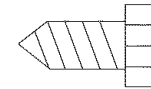

1/4" x 5/8" Screw (95)

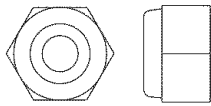

5/16" Nylon Locknut (64)

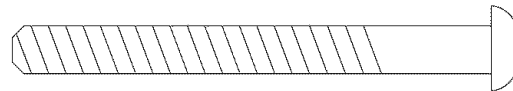

1/4" x 2 1/2" Carriage Bolt (45)

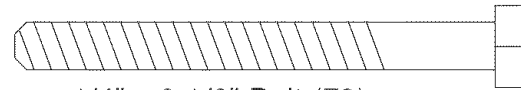

1/4" x 2 1/2" Bolt (79)

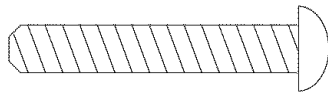

1/4" x 1 1/2" Carriage Bolt (101)



5/16" x 3 3/4" Bolt (66)

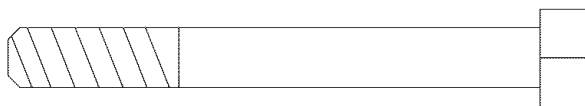

5/16" x 2 3/4" Bolt (89)

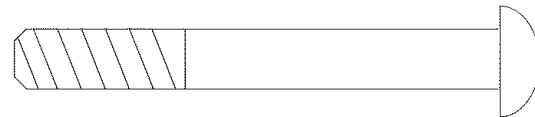

5/16" x 2 1/2" Carriage Bolt (92)



3/8" x 9" Bolt (52)

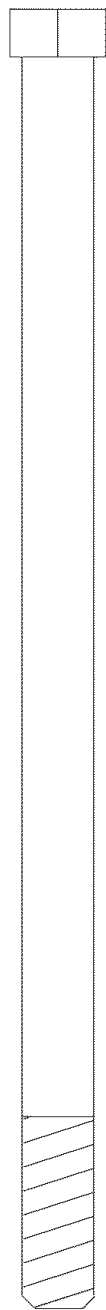

3/8" x 6 1/2" Bolt (55)

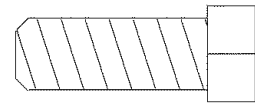

3/8" x 1" Bolt (84)

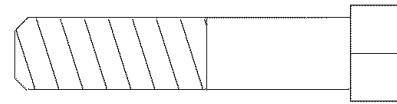

3/8" x 1 3/4" Bolt (57)

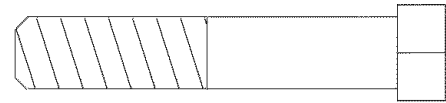

3/8" x 2" Bolt (54)

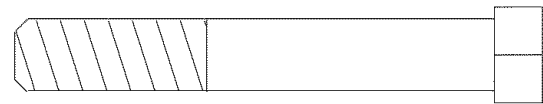

3/8" x 2 1/2" Bolt (53)

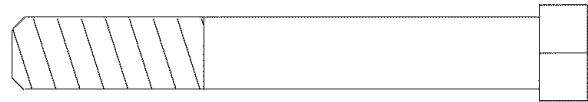

3/8" x 2 3/4" Bolt (46)

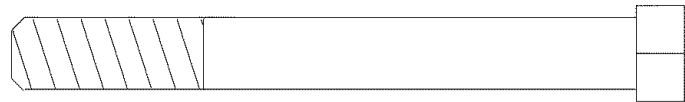

3/8" x 3 1/4" Bolt (62)

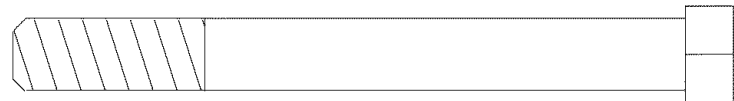

3/8" x 3 1/2" Bolt (56)

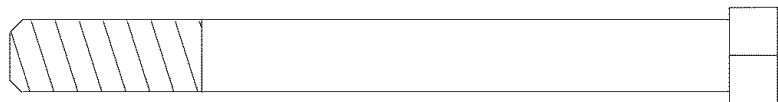

3/8" x 3 3/4" Bolt (59)

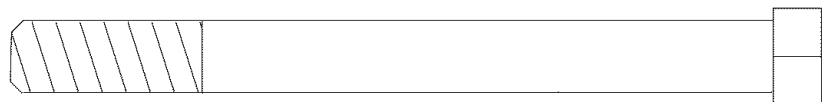

3/8" x 4" Bolt (60)

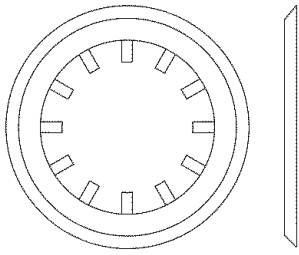

Retainer Ring (31)

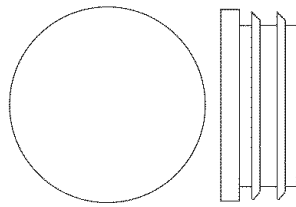

1" Inner Cap (76)

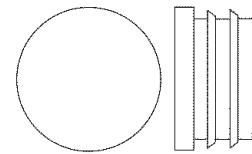

3/4" Round Inner Cap (43)

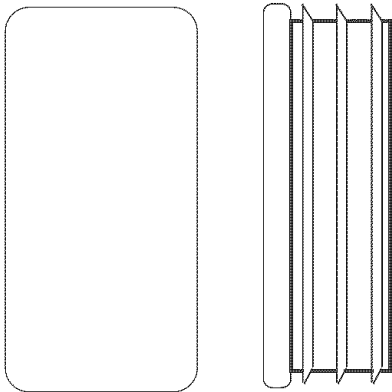

1" x 2" Inner Cap (83)

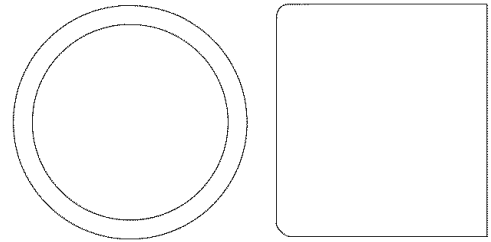

1" Round Outer Cap (38)

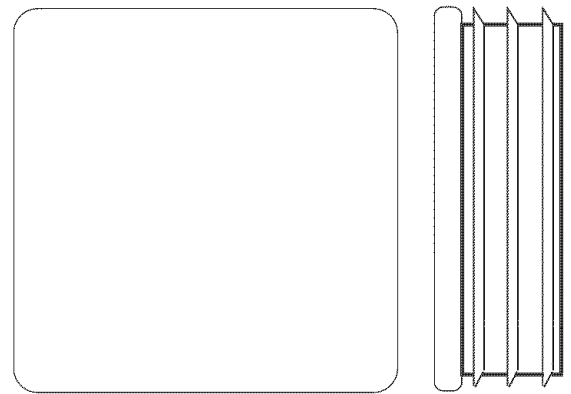

2" Square Inner Cap (28)

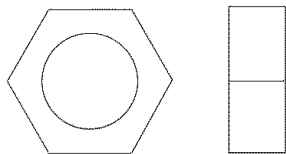

1/2" Plain Nut (100)

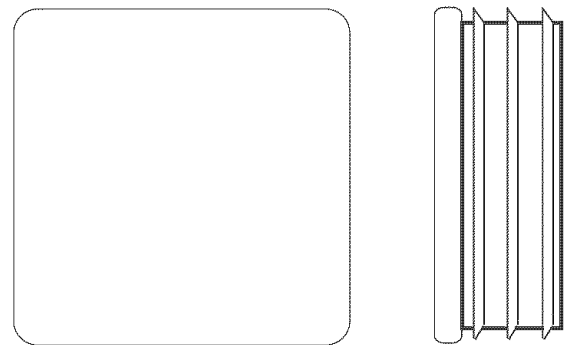

1 3/4" Square Inner Cap (35)

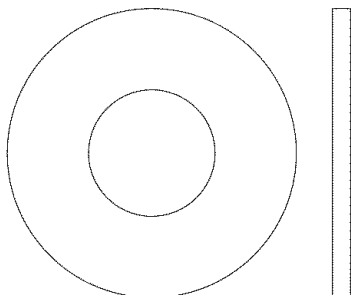

1/2" Flat Washer (98)

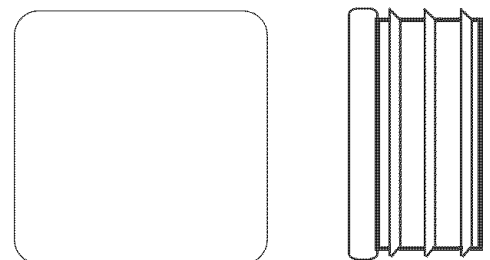

1 1/4" Square Inner Cap (82)

# Part List—Model No. NTSY73690

R0100A

Key No.	Qty.	Description	Key No.	Qty.	Description
1	1	Butterfly Upright	55	2	3/8" x 6 1/2" Bolt
2	1	Press Upright	56	3	3/8" x 3 1/2" Bolt
3	1	Butterfly Front Leg	57	5	3/8" x 1 3/4" Bolt
4	1	Butterfly Base	58	1	Nylon Strap
5	1	Weight Base	59	6	3/8" x 3 3/4" Bolt
6	1	Press Base	60	1	3/8" x 4" Bolt
7	1	Press Seat Frame	61	1	Lat Bar
8	1	Press Frame	62	1	3/8" x 3 1/4" Bolt
9	1	Weight Upright	63	11	3/8" Nylon Jam Nut
10	1	Right Butterfly Arm	64	32	5/16" Nylon Locknut
11	1	Left Butterfly Arm	65	3	Seat Plate
12	1	Butterfly Backrest	66	4	5/16" x 3 3/4" Bolt
13	2	Seat	67	1	Chain
14	1	Butterfly Seat Frame	68	3	1/4" Nylon Locknut
15	2	Weight Guide	69	4	Cable Clip
16	1	Top Weight	70	2	Backrest Adjustment Frame
17	1	Weight Tube	71	8	1/4" Flat Washer
18	1	Weight Tube Bumper	72	1	Weight Cable
19	1	Weight Pin	73	1	Butterfly Cable
20	1	Press Front Leg	74	1	Ab Cable
21	14	Weight	75	1	Low Cable
22	1	Pulley Frame	76	2	1" Inner Cap
23	4	Adjustable Pulley Plate	77	2	Press Arm
24	22	3 1/2" Pulley	78	4	Nylon Jam Nut
25	14	Cable Trap	79	1	1/4" x 2 1/2" Bolt
26	1	Weight Support	80	1	1" Tap Screw
27	3	"V"-Pulley	81	1	Ab Strap
28	19	2" Square Inner Cap	82	3	1 1/4" Square Inner Cap
29	2	Butterfly Foam Pad	83	6	1" x 2" Inner Cap
30	4	Foam Roller	84	2	3/8" x 1" Bolt
31	4	Retainer Ring	85	3	Adjustment Handle
32	3	Large Cable Trap	86	2	Small Grip
33	1	Right Support Frame	87	2	Butterfly Grip
34	1	Shroud	88	2	Press Grip
35	3	1 3/4" Square Inner Cap	89	18	5/16" x 2 3/4" Bolt
36	16	5/16" Washer	90	1	Seat Adjustment Frame
37	2	Butterfly Arm Bushing	91	1	Curl Pad
38	2	1" Round Outer Cap	92	10	5/16" x 2 1/2" Carriage Bolt
39	4	Plastic Grip	93	1	Workout Decal
40	1	Bumper	94	28	Weight Insert
41	1	Leg Lever	95	3	1/4" x 5/8" Screw
42	2	Pad Tube	96	1	Long Spacer
43	4	3/4" Round Inner Cap	97	1	Left Support Frame
44	1	Row Bar	98	1	1/2" Flat Washer
45	1	1/4" x 2 1/2" Carriage Bolt	99	1	Press Backrest
46	3	3/8" x 2 3/4" Bolt	100	1	1/2" Plain Nut
47	2	Pulley Cover	101	2	1/4" x 1 1/2" Carriage Bolt
48	17	3/8" Flat Washer	102	2	5/8" x 1/2" Spacer
49	8	1/4" x 3/4" Bolt	103	8	1/4" x 1 1/2" Screw
50	24	3/8" Nylon Locknut	104	1	Plastic Weight Cover
51	2	Weight Bumper	105	1	1/2" x 3/4" Spacer
52	1	3/8" x 9" Bolt	106	1	3/8" x 1 1/4" Button Head Bolt
53	2	3/8" x 2 1/2" Bolt	#	1	User's Manual
54	7	3/8" x 2" Bolt			

Note: "#" indicates a non-illustrated part. Specifications are subject to change without notice.

# Exploded Drawing—Model No. NTSY73690

R0100A

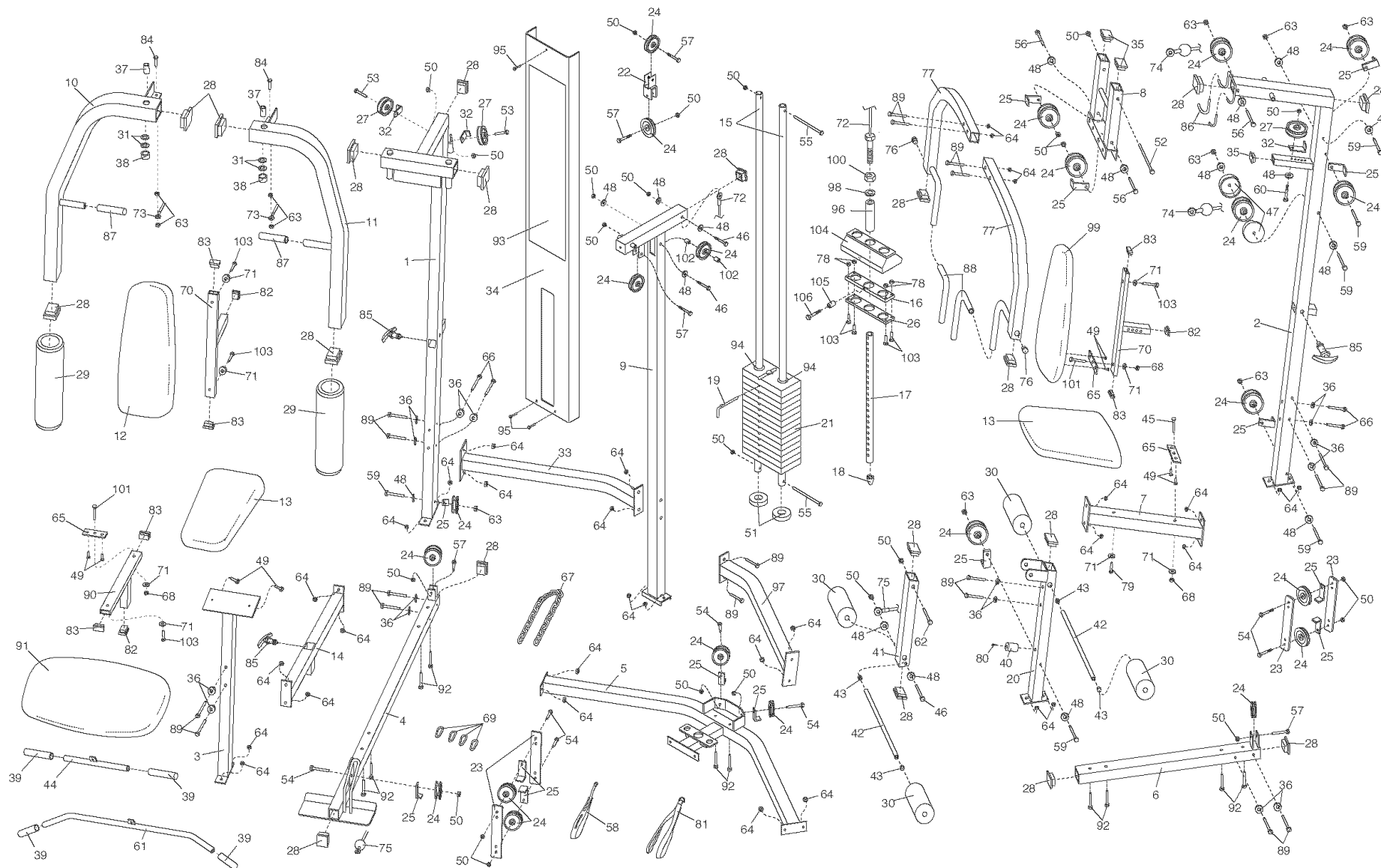



# Ordering Replacement Parts

To order replacement parts, simply call our Customer Service Department toll-free at 1-888-825-2588, Monday through Friday, 6 a.m. until 6 p.m. Mountain Time (excluding holidays). To help us assist you, please be prepared to give the following information:

1. The MODEL NUMBER of the product (NTSY73690)
2. The NAME of the product (NORDICTRACK® GRT470 home gym)
3. The SERIAL NUMBER of the product (see the front cover of this manual)
4. The KEY NUMBER and DESCRIPTION of the part(s) (see the PART LIST and EXPLODED DRAWING attached at the center of this manual).

NordicTrack is a registered trademark of ICON Health & Fitness, Inc.

## Limited Warranty

ICON Health & Fitness, Inc. (ICON), warrants this product to be free from defects in workmanship and material, under normal use and service conditions, for a period of one year from the date of purchase. This warranty extends only to the original purchaser. ICON's obligation under this warranty is limited to replacing or repairing, at ICON's option, the product at one of its authorized service centers. All products for which warranty claim is made must be received by ICON at one of its authorized service centers with all freight and other transportation charges prepaid, accompanied by sufficient proof of purchase. All returns must be pre-authorized by ICON. This warranty does not extend to any product or damage to a product caused by or attributable to freight damage, abuse, misuse, improper or abnormal usage or repairs not provided by an ICON authorized service center, products used for commercial or rental purposes, or products used as store display models. No other warranty beyond that specifically set forth above is authorized by ICON.

ICON is not responsible or liable for indirect, special or consequential damages arising out of or in connection with the use or performance of the product or damages with respect to any economic loss, loss of property, loss of revenues or profits, loss of enjoyment or use, costs of removal, installation or other consequential damages of whatsoever nature. Some states do not allow the exclusion or limitation of incidental or consequential damages. Accordingly, the above limitation may not apply to you.

The warranty extended hereunder is in lieu of any and all other warranties and any implied warranties of merchantability or fitness for a particular purpose is limited in its scope and duration to the terms set forth herein. Some states do not allow limitations on how long an implied warranty lasts. Accordingly, the above limitation may not apply to you.

This warranty gives you specific legal rights. You may also have other rights which vary from state to state.

**ICON HEALTH & FITNESS, INC., 1500 S. 1000 W., LOGAN, UT 84321-9813**