



# NordicTrack®

## SL 710

Patent Pending

Model No. NTC07940

Serial No. \_\_\_\_\_

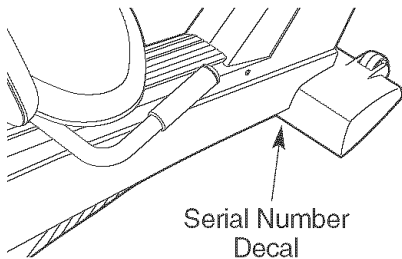

## USER'S MANUAL

### QUESTIONS?

As a manufacturer, we are committed to providing complete customer satisfaction. If you have questions, or if there are missing parts, we will guarantee satisfaction through direct assistance from our factory.

**TO AVOID DELAYS, PLEASE CALL DIRECT TO OUR TOLL-FREE CUSTOMER HOT LINE.** The trained technicians on our customer hot line will provide immediate assistance, free of charge to you.

**CUSTOMER HOT LINE:**

**1-888-825-2588**

Mon.-Fri., 6 a.m.-6 p.m. MST

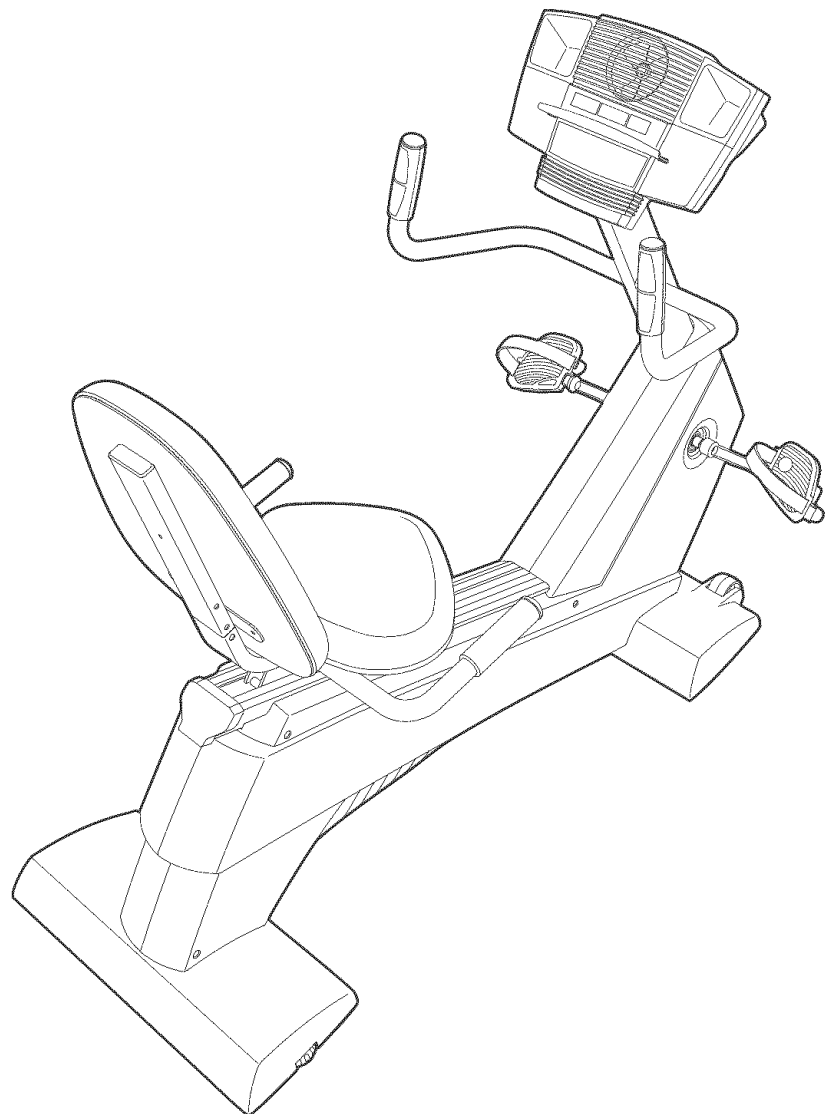

### **CAUTION**

Read all precautions and instructions in this manual before using this equipment. Keep this manual for future reference.



Visit our website at

[www.nordictrack.com](http://www.nordictrack.com)

*new products, prizes,  
fitness tips, and much more!*

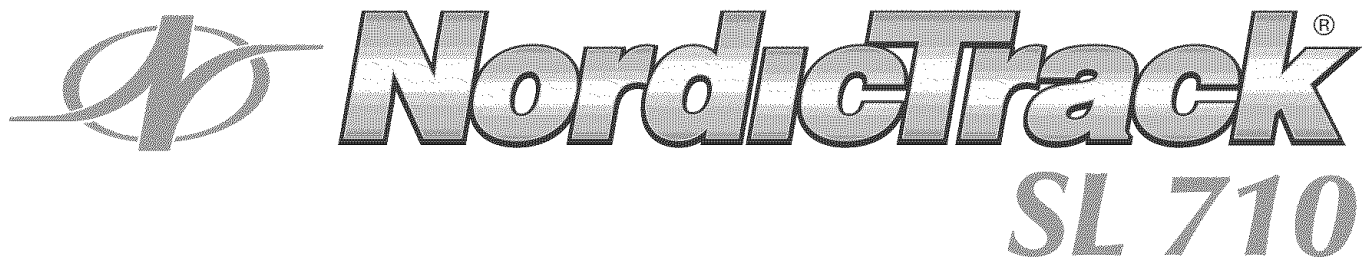

---

## TABLE OF CONTENTS

IMPORTANT PRECAUTIONS .....	3
BEFORE YOU BEGIN .....	4
ASSEMBLY .....	5
HOW TO OPERATE THE EXERCISE CYCLE .....	10
MAINTENANCE AND TROUBLESHOOTING .....	22
EXERCISE GUIDELINES .....	23
PART LIST .....	25
EXPLODED DRAWING .....	26
HOW TO ORDER REPLACEMENT PARTS .....	Back Cover
LIMITED WARRANTY .....	Back Cover

---

## IMPORTANT PRECAUTIONS

**▲ WARNING:** To reduce the risk of serious injury, read the following important precautions before using the exercise cycle.

1. Read all instructions in this manual before using the exercise cycle. Use the exercise cycle only as described.
2. It is the responsibility of the owner to ensure that all users of the exercise cycle are adequately informed of all precautions.
3. Use the exercise cycle indoors on a level surface. Keep the exercise cycle away from moisture and dust. Place a mat under the exercise cycle to protect the floor or carpet.
4. Inspect and properly tighten all parts regularly. Replace any worn parts immediately.
5. Keep children under the age of 12 and pets away from the exercise cycle at all times.
6. The exercise cycle should not be used by persons weighing more than 250 pounds.
7. Wear suitable clothing when using the exercise cycle; do not wear loose clothing that could become caught on the exercise cycle. Always wear athletic shoes.
8. Always keep your back straight when using the exercise cycle. Do not arch your back.
9. If you feel pain or dizziness while exercising, stop immediately and cool down.
10. The pulse sensor is not a medical device. Various factors, including the user's movement, may affect the accuracy of heart rate readings. The pulse sensor is intended only as an exercise aid in determining heart rate trends in general.
11. The exercise cycle is intended for in-home use only. Do not use the exercise cycle in a commercial, rental, or institutional setting.

**▲ WARNING:** Before beginning this or any exercise program, consult your physician. This is especially important for persons over the age of 35 or persons with pre-existing health problems. Read all instructions before using. ICON assumes no responsibility for personal injury or property damage sustained by or through the use of this product.

# BEFORE YOU BEGIN

Congratulations for selecting the new NordicTrack® SL 710 exercise cycle. Cycling is one of the most effective exercises for increasing cardiovascular fitness, building endurance, and toning the entire body. The NordicTrack® SL 710 offers an impressive array of features designed to let you enjoy this healthful exercise in the comfort and privacy of your home.

**For your benefit, read this manual carefully before you use the exercise cycle.** If you have questions after reading this manual, call our Customer Service

Department toll-free at 1-888-825-2588, Monday through Friday, 6 a.m. until 6 p.m. Mountain Time (excluding holidays). To help us assist you, mention the product model number and serial number when calling. The model number is NTC07940. The serial number can be found on a decal attached to the exercise cycle (see the front cover of this manual for the location of the decal).

Before reading further, please familiarize yourself with the parts that are labeled in the drawing below.

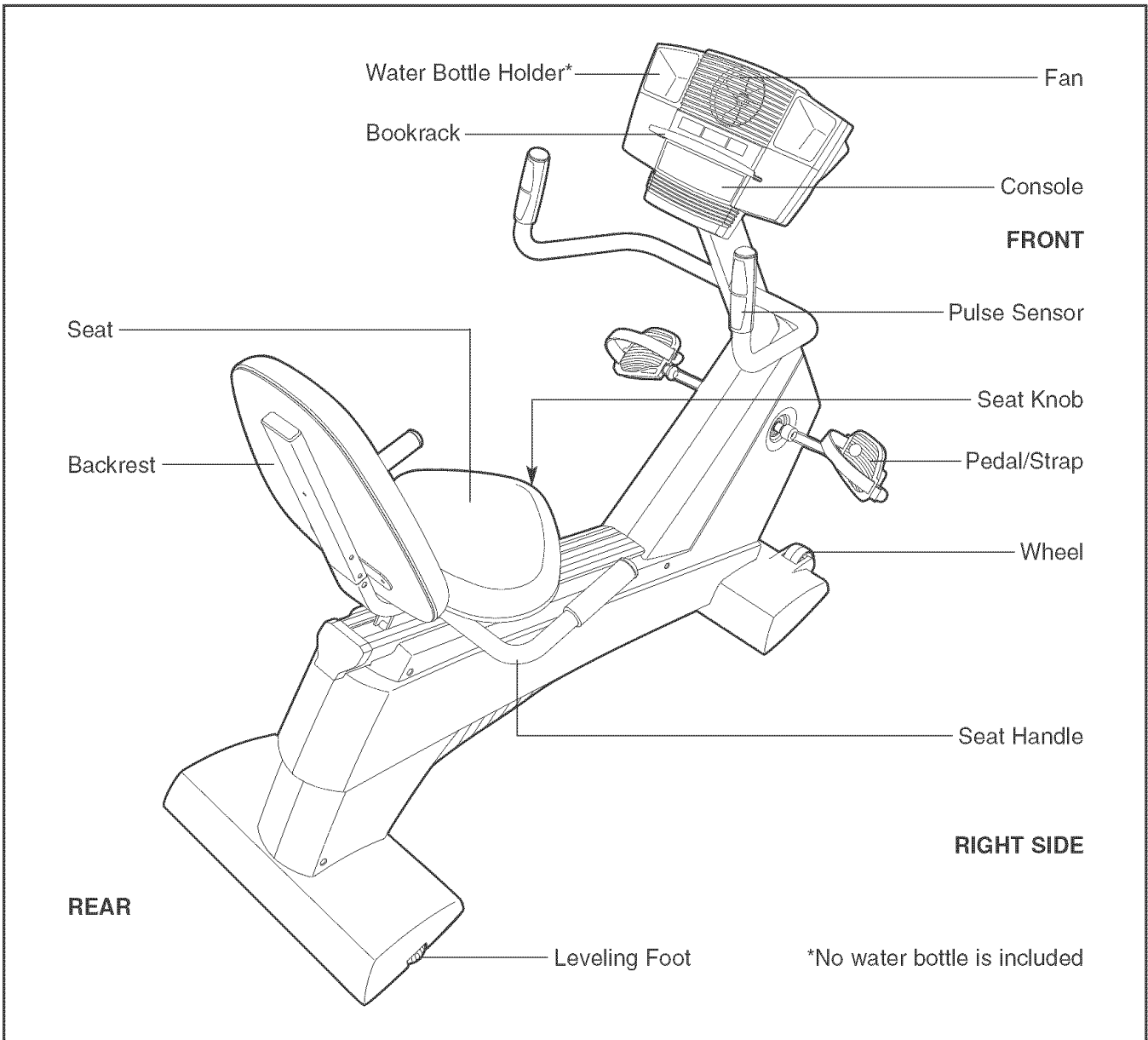

# ASSEMBLY

Assembly requires two persons. Place all parts of the exercise cycle in a cleared area and remove the packing materials. Do not dispose of the packing materials until assembly is completed.

Assembly requires the included tools and your own adjustable wrench .

Use the drawings below to identify the small parts used during assembly. The number in parenthesis below each drawing is the key number of the part, from the PART LIST on page 25. The number following the key number is the quantity needed for assembly. **Note: Some small parts may have been pre-assembled. If a part is not in the parts bag, check to see if it has been pre-assembled.**

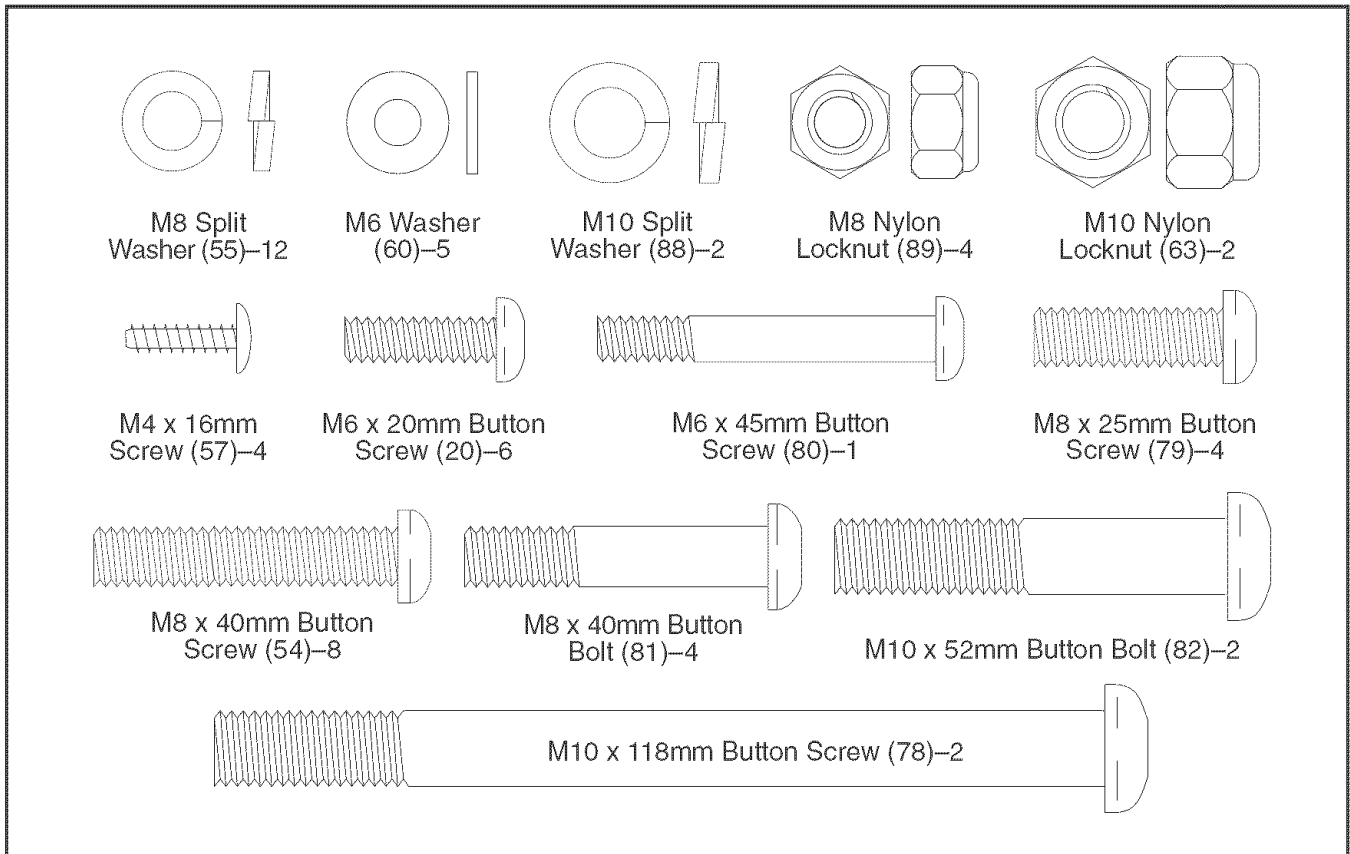

1. Identify the Front Stabilizer (15). While another person lifts the front of the Frame (1), attach the Front Stabilizer to the Frame with four M8 x 40mm Button Screws (54) and four M8 Split Washers (55).

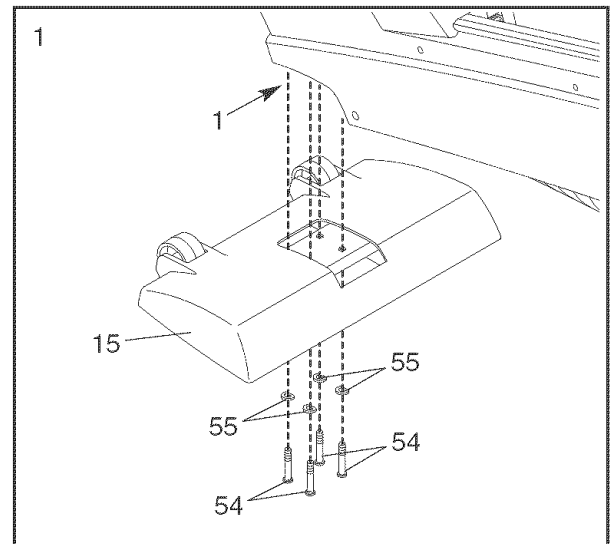

2. While another person lifts the rear of the Frame (1), attach the Rear Stabilizer (16) to the Frame with four M8 x 40mm Button Screws (54) and four M8 Split Washers (55).

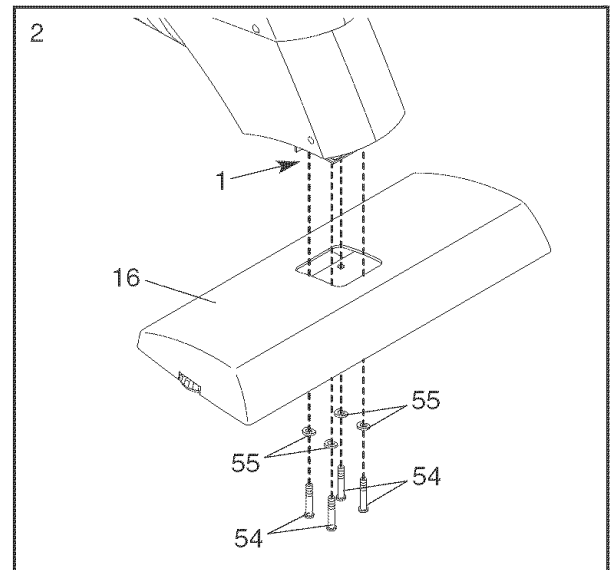

3. While another person holds the Upright (2) in the position shown, connect the Upper Wire Harness (97) to the Lower Wire Harness (43). Gently pull the upper end of the Upper Wire Harness to remove any slack from the Wire Harnesses.

Insert the Upright (2) into the Frame (1). **Be careful to avoid pinching the Wire Harnesses (43, 97).** Attach the Upright with two M10 x 118mm Button Screws (78), two M10 Split Washers (88), and two Upright Spacers (99). **Make sure the concave end of each Upright Spacer is turned toward the Upright.**

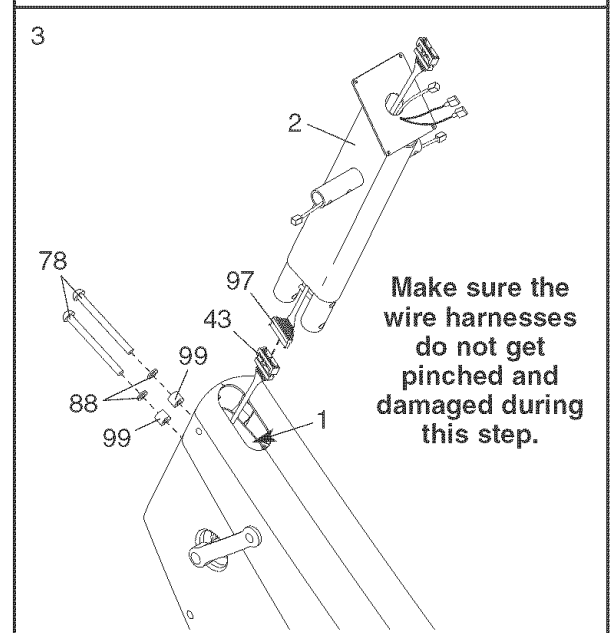

4. Identify the Left Handlebar (70), which is marked with an "L" sticker. Hold the Left Handlebar near the Upright (2). Connect the left Pulse Sensor Wire (6) to the Pulse Wire (3).

Slide the Left Handlebar (70) onto the indicated tube on the Upright (2). **Be careful to avoid pinching the left Pulse Sensor Wire (6) or the Pulse Wire (3).** Carefully insert two M8 x 40mm Button Bolts (81) through the Left Handlebar and the tube on the Upright. **Be careful not to damage the Wires with the Button Bolts.** Tighten the two Button Bolts into two M8 Nylon Locknuts (89). **Make sure the Nylon Locknuts are seated in the hexagonal holes in the Left Handlebar.**

Attach the Right Handlebar (72) in the same way.

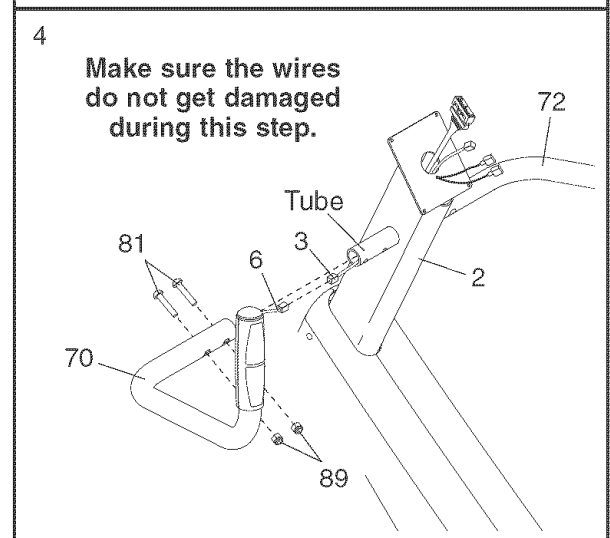

5. Have another person hold the Console (4) near the Upright (2).

Connect the Upper Wire Harness (97) to the wire harness on the Console (4). Connect the Pulse Wire (3) to the pulse wire on the Console. Next, locate the two ground wires that are connected with a screw to the Upright (2), and connect the ground wires to the two smallest wires on the Console.

Carefully insert all excess wiring down into the Upright (2). Attach the Console (4) to the Upright with four M4 x 16mm Screws (57). **Be careful to avoid pinching the wires.** Next, press the bookrack onto the Console in the indicated location.

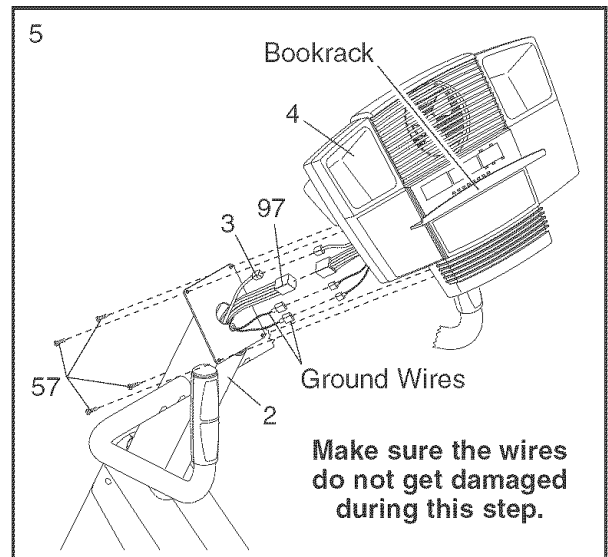

6. Attach the Seat (9) to the Seat Frame (7) with four M6 x 20mm Button Screws (20) and four M6 Washers (60).

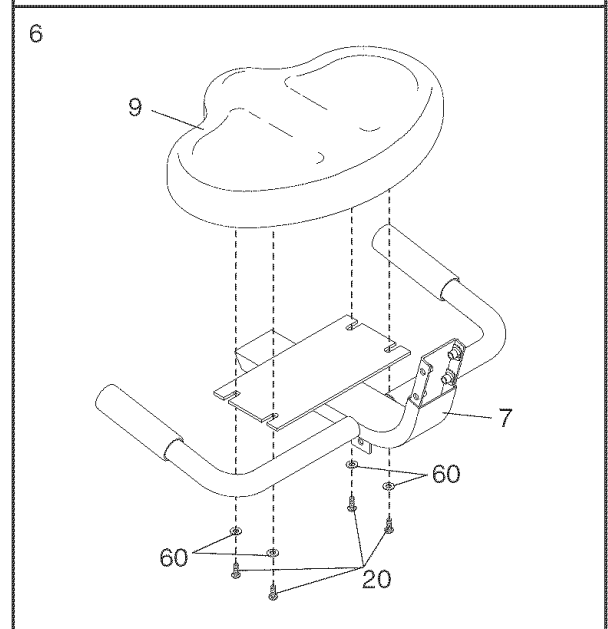

7. Attach the Seat Frame (7) to the Seat Carriage (11) with two M10 x 52mm Button Bolts (82) and two M10 Nylon Locknuts (63).

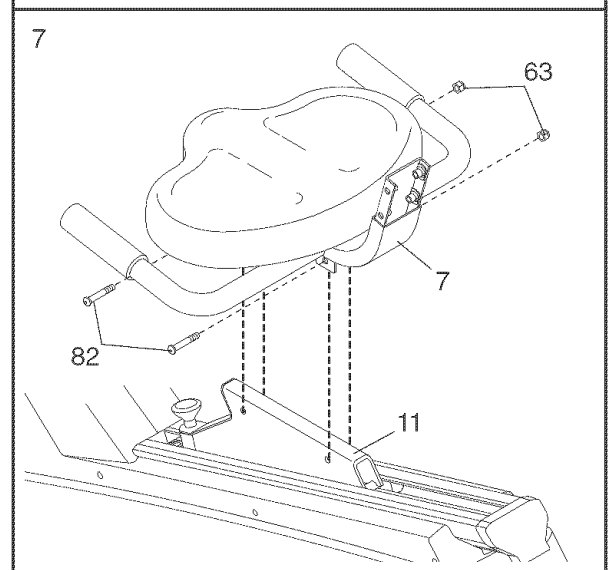

8. Attach the Backrest (62) and the Seat Back (98) to the Backrest Frame (42) with two M6 x 20mm Button Screws (20), an M6 x 45mm Button Screw (80), and an M6 Washer (60).

Slide the Backrest Frame (42) onto the Seat Frame (7). Attach the Backrest Frame with four M8 x 25mm Button Screws (79) and four M8 Split Washers (55).

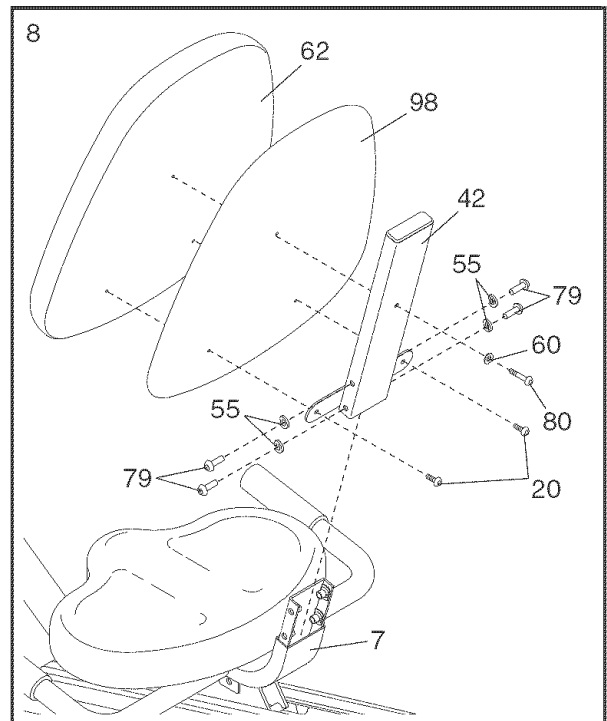

9. Identify the Left Pedal (22), which is marked with an "L." Using an adjustable wrench, **firmly tighten** the Left Pedal *counterclockwise* into the Left Crank Arm (24). Tighten the Right Pedal (not shown) *clockwise* into the Right Crank Arm. **Important: Tighten both Pedals as firmly as possible. After using the exercise cycle for one week, retighten the Pedals. For best performance, the Pedals must be kept tightened.**

Identify the Left Pedal Strap (25), which is marked with an "L." Attach the Left Pedal Strap to the Left Pedal (22), and adjust it to the desired position. Attach and adjust the Right Pedal Strap (not shown) in the same way.

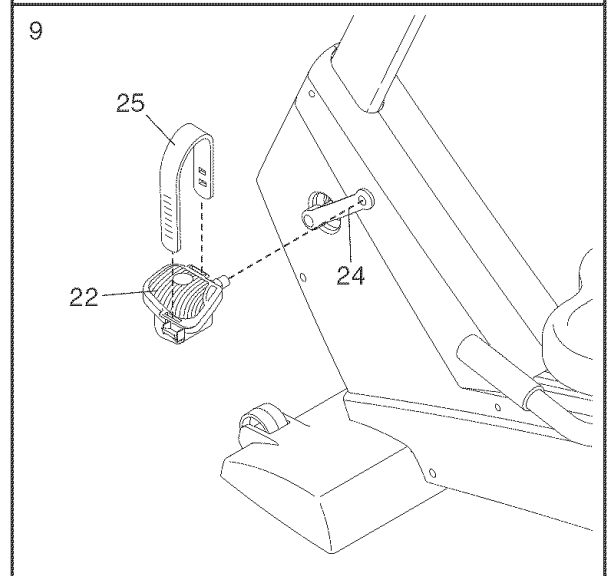

10. The Console (4) requires four "D" batteries (not included); alkaline batteries are recommended. Slide the battery cover off the Console. Insert four batteries into the battery compartment. **Make sure that the batteries are oriented as shown by the diagram inside the battery compartment.** Slide the battery cover back onto the Console. Note: When the batteries are installed correctly, the fan will turn on for a moment.

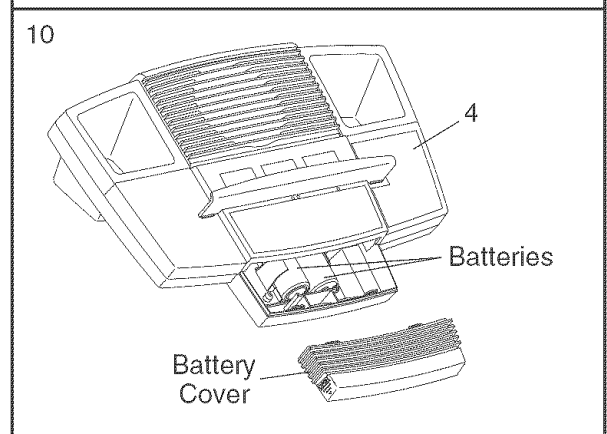

11. **Make sure that all parts are properly tightened before you use the exercise cycle.** Note: After assembly is completed, some extra parts may be left over. Place a mat beneath the exercise cycle to protect the floor.



## INSTALLING THE RECEIVER FOR THE OPTIONAL CHEST PULSE SENSOR

If you purchase the optional chest pulse sensor (see page 21), follow the steps below to install the receiver included with the chest pulse sensor.

Remove the access door from the underside of the Console (4). You may need to use a small standard screwdriver to remove the access door.

Slide the receiver onto the indicated plastic pin on the Console (4); **make sure that the receiver is oriented exactly as shown**. Locate the two small screws included with the chest pulse sensor. Attach the receiver to the Console with the two screws as shown.

Connect the wire on the receiver to the indicated wire on the Console (4).

Reattach the access door. **Make sure that no wires are pinched**. Note: The other wires included with the chest pulse sensor may be discarded.

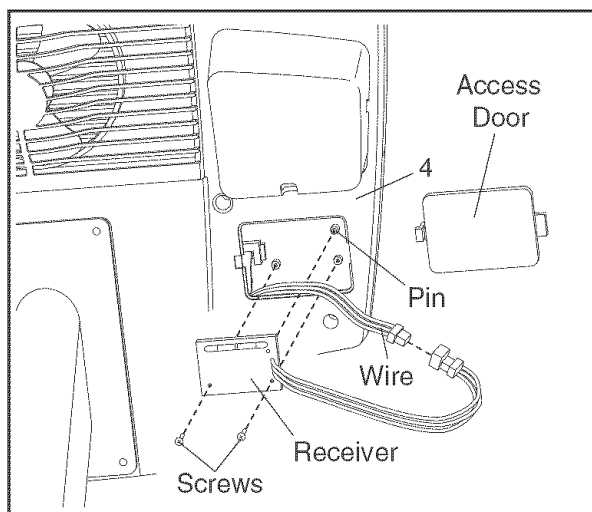

# HOW TO OPERATE THE EXERCISE CYCLE

## HOW TO MOVE AND LEVEL THE EXERCISE CYCLE

Stand in back of the exercise cycle, and lift the exercise cycle until it can be moved on the front wheels. Move the exercise cycle to the desired location and carefully lower it. **Due to the weight of the exercise cycle, use extreme caution while moving it.**

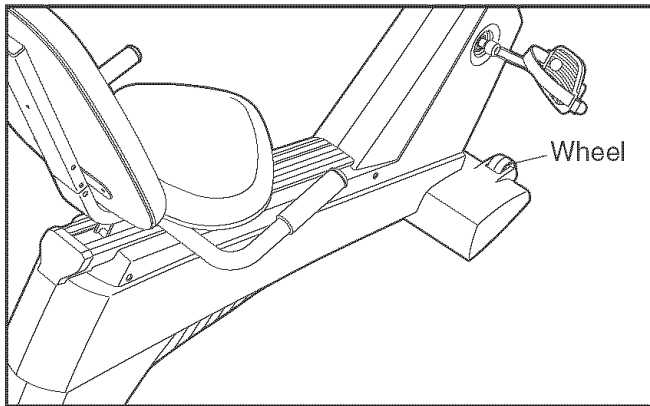

If the exercise cycle rocks slightly during use, turn the leveling feet under the rear stabilizer until the rocking motion is eliminated.

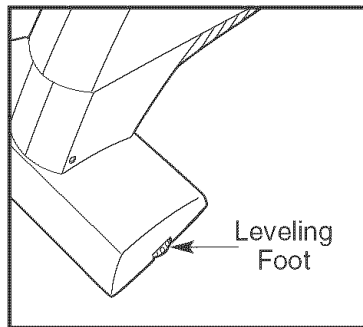

## HOW TO ADJUST THE SEAT

The seat can be adjusted to the position that is the most comfortable for you. To adjust the seat, pull the seat knob, slide the seat forward or backward, and then release the seat knob. Move the seat forward or backward slightly until the pin on the seat knob snaps into one of the holes in the seat rail.

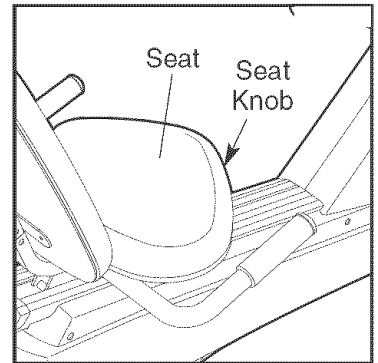

## HOW TO ADJUST THE PEDAL STRAPS

The pedal straps can be adjusted to the position that is the most comfortable for you. Press the tabs on the pedals, adjust the straps to the desired position, and then release the tabs.

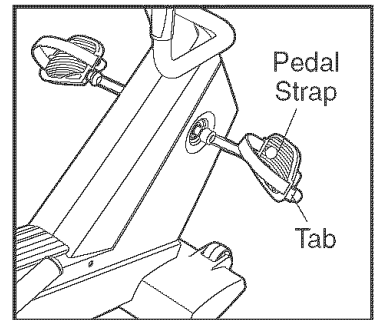

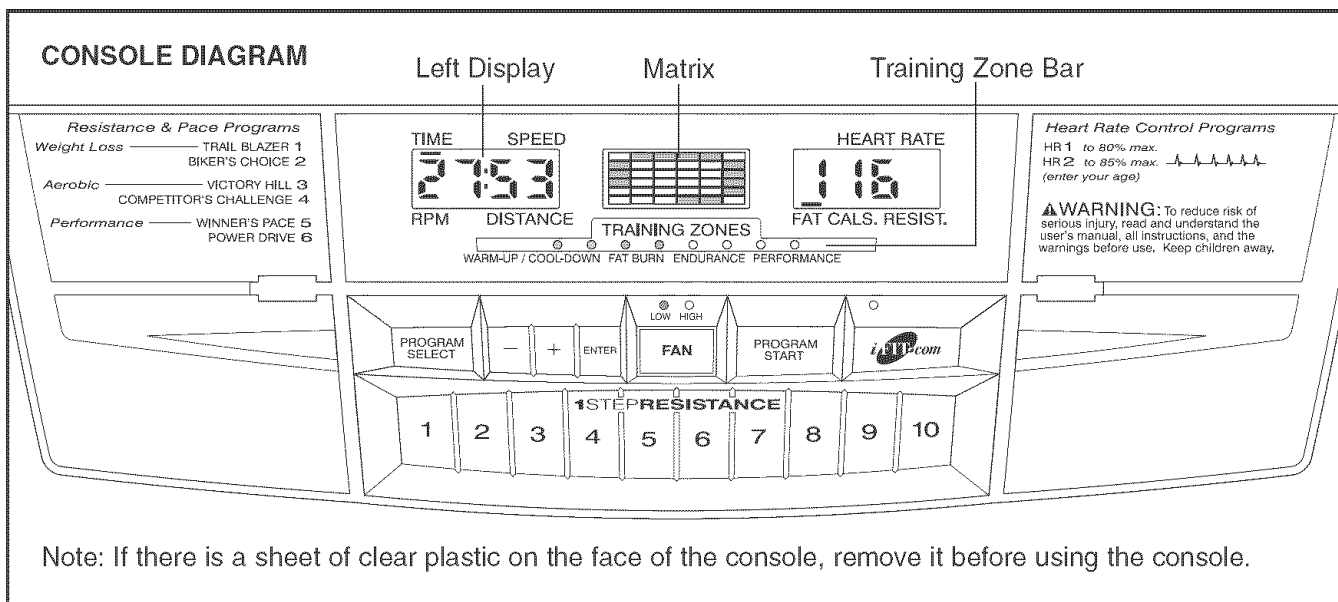

### FEATURES OF THE CONSOLE

The advanced console offers a selection of features designed to make your workouts more enjoyable and effective. When the manual mode of the console is selected, the resistance of the exercise cycle can be changed with the touch of a button. As you exercise, the console will provide continuous exercise feedback. You can even measure your heart rate using the hand-grip pulse sensor. Note: For information about an optional chest pulse sensor, see page 21.

The console also offers six resistance and pace programs. Each program automatically changes the resistance of the exercise cycle and prompts you to increase or decrease your pace as it guides you through an effective workout.

In addition, the console features two heart rate programs that automatically change the resistance of the exercise cycle and prompt you to vary your pace to keep your heart rate near a target heart rate as you exercise.

The console also features iFIT.com interactive technology. Having iFIT.com technology is like having a personal trainer in your home. Using the included audio cable, you can connect the exercise cycle to your home stereo, portable stereo, computer, or VCR and play special iFIT.com CD and video programs (iFIT.com CDs and videocassettes are available separately). iFIT.com CD and video programs automatically control the resistance of the exercise cycle and prompt you to vary your pace as a personal trainer coaches you through every step of your workout. High-energy music provides added motivation. **To purchase iFIT.com CDs and videocassettes, call toll-free 1-800-735-0768.**

With the exercise cycle connected to your computer, you can also go to our Web site at [www.iFIT.com](http://www.iFIT.com) and access programs directly from the internet. **Explore [www.iFIT.com](http://www.iFIT.com) for more information.**

## HOW TO USE THE MANUAL MODE

### 1 Press any button on the console or begin pedaling to turn on the console.

Note: The console requires four 1.5V “D” batteries (see assembly step 10 on page 8).

Press any button on the console or begin pedaling to turn on the console. After a few seconds, the console displays will light, a tone sound, and the console will be ready for use.

### 2 Select the manual mode.

When the power is turned on, the manual mode will be selected. If you have selected a program or the iFIT.com mode, reselect the manual mode by pressing the Program Select button repeatedly until a track appears in the matrix.

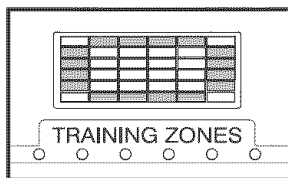

### 3 Begin pedaling and change the resistance of the exercise cycle as desired.

As you pedal, change the resistance of the exercise cycle by pressing the Resistance buttons. There are ten resistance levels. Note: After the Resistance buttons are pressed, it will take a moment for the exercise cycle to reach the selected resistance level.

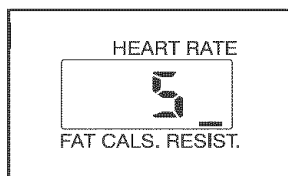

### 4 Monitor your progress with the matrix, the Training Zone bar, and the two displays.

**The matrix**—When the manual mode is selected, the matrix will show a track representing 1/4 mile. As you pedal, the indica-

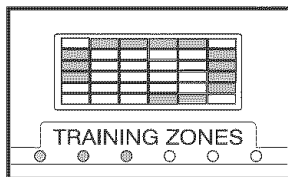

tors around the track will light in succession until the entire track is lit. The track will then darken and the indicators will again begin to light in succession.

**The Training Zone bar**—The Training Zone bar will show your pace and the approximate intensity level of your exercise.

For example, if three or four indicators in the bar are lit, the bar shows that your pace is ideal for fat burning. During programs, the Training Zone bar will also prompt you to increase or decrease your pace.

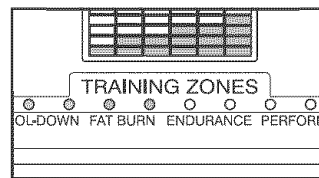

**The left display**—

The left display will show the elapsed time, your pedaling pace (in revolutions per minute), the distance you have pedaled, and your pedaling speed. The display will change from one number to the next every few seconds, as shown by the mode indicators in the display. Note: When a program is selected, the display will show the time remaining in the program instead of the elapsed time.

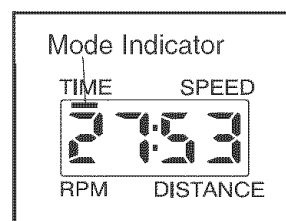

**The right display**—

The right display will show the approximate numbers of *fat calories* and *calories* you have burned (see FAT BURNING on page 23) and the resistance level of the exercise cycle. The display will change from one number to the next every few seconds, as shown by the mode indicators. The display will also show your heart rate when you use the handgrip pulse sensor or the optional chest pulse sensor. Note: Each time the resistance of the exercise cycle changes, the display will show the resistance level.

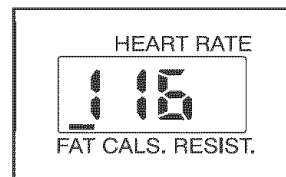

Note: The console can display speed and distance in either miles or kilometers. To find which unit of measurement is selected, you must select the console's user mode. Hold down the Program Select button for about three seconds. The letter "E" for English miles or the letter "M" for metric kilometers will appear in the left display. To change the unit of measurement, press the + button.

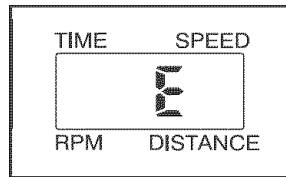

While the user mode is selected, press the Program Start button. The left display will then show the total number of hours that the exercise cycle has been used. Press the Program Start button again. The left display will then show the total number of miles pedaled. To exit the user mode, press the Program Select button again.

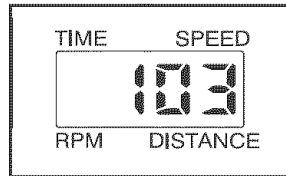

## 5 Measure your heart rate if desired.

**Note: If you wear the optional chest pulse sensor and hold the handgrip pulse sensor at the same time, the console may not display your heart rate accurately.**

If there are thin sheets of plastic on the metal contacts on the handgrip pulse sensor, peel off the plastic. To measure your heart rate, hold the contacts; your palms must be resting on the upper contacts, and your fingers must be touching the lower contacts. **Avoid moving your hands.**

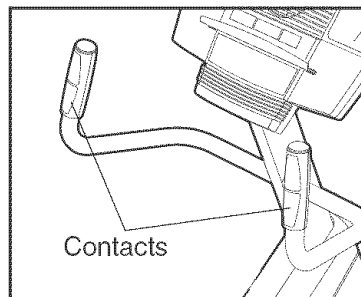

When your pulse is detected, the heart-shaped indicator in the right display will flash each time your heart beats, one or two dashes (—) will appear, and then your heart rate will be shown. For the most accurate heart rate reading, hold the contacts for at least 15 seconds.

Note: If you continue to hold the pulse sensor, the right display will show your heart rate for up to 30 seconds. The display will then show your heart rate along with the other modes.

If your heart rate is not shown, make sure that your hands are positioned as described. Be careful not to move your hands excessively or to squeeze the metal contacts too tightly. For optimal performance, clean the metal contacts using a soft cloth; never use alcohol, abrasives, or chemicals.

## 6 Turn on the fan if desired.

To turn on the fan at low speed, press the Fan button. Pivot the fan to the desired angle. To turn on the fan at high speed, press the Fan button a second time. To turn off the fan, press the Fan button a third time. Note: If the pedals are not moved for about thirty seconds, the fan will automatically turn off.

## 7 When you are finished exercising, the console will automatically turn off.

If the pedals are not moved for several seconds, a tone will sound, the console will pause, and the left display will begin to flash. If the pedals are not moved for about five minutes, the console will turn off and the displays will be reset.

## HOW TO USE RESISTANCE AND PACE PROGRAMS

- 1 Press any button on the console or begin pedaling to turn on the console.

See step 1 on page 12.

- 2 Select one of the six resistance and pace programs.

When the power is turned on, the manual mode will be selected. To select a resistance and pace program, press the Program Select button repeatedly until a "P 1," "P 2," "P 3," "P 4," "P 5," or "P 6" appears in the right display.

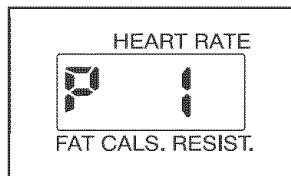

Each program is divided into several time segments of different lengths. One resistance setting and one pace setting are programmed for each segment. (Note: The same resistance setting and/or pace setting may be programmed for two or more consecutive segments.) The resistance setting for the first segment is shown in the left column of the matrix. The resistance settings for the next five segments are shown in the columns to the right. Note: One bar in a column represents a resistance setting of level 1, two bars represent level 2 or 3, three bars represent level 4 or 5, four bars represent level 6 or 7, five bars represent level 8 or 9, and six bars represent level 10.

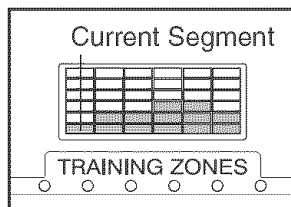

- 3 Press the Program Start button or begin pedaling to start the program.

When the program is started, the left column of the matrix will begin to flash, and the exercise cycle will automatically adjust to the resistance setting for the first segment.

As you exercise, the Training Zone bar will help you to keep your pedaling pace near the pace

setting for the current segment. The lit indicators in the bar will show your actual pace. If an indicator to the *right* of the lit indicators is flashing (see drawing a), increase your pace. If an indicator to the *left* of any lit indicator is flashing (see drawing b), decrease your pace. When no indicator is flashing, your pace matches the pace setting for the current segment. **Important: The pace settings are intended only to provide motivation. Your actual pace may be slower than the current pace setting. Make sure to exercise at a pace that is comfortable for you.**

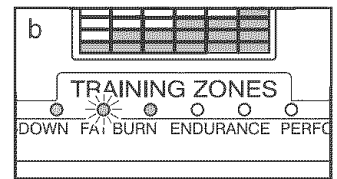
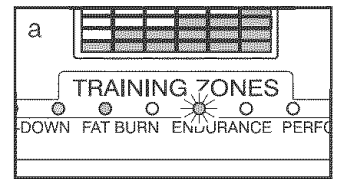

When the first segment of the program ends, a series of tones will sound and *all resistance settings will move one column to the left*. The resistance setting for the second segment will then be shown in the left column of the matrix and the resistance of the exercise cycle will automatically change to the resistance setting for the second segment.

Note: During the program, you can override the resistance setting, if desired, by pressing the Resistance buttons. However, when the next segment begins, the resistance will change if a different resistance setting is programmed for the next segment.

If you stop pedaling for several seconds, a tone will sound and the program will pause. To restart the program, simply resume pedaling. The program will continue until the resistance setting for the last segment is shown in the left column of the matrix and the last segment ends.

- 4 Monitor your progress with the two displays.

See step 4 on page 12.

- 5 Measure your heart rate if desired.

See step 5 on page 13.

**6 Turn on the fan if desired.**

See step 6 on page 13.

**7 When the program is finished, the console will automatically turn off.**

See step 7 on page 13.

**HOW TO USE HEART RATE PROGRAMS**

Each heart rate program helps you to keep your heart rate near a certain percentage of your *maximum heart rate* during your workout. (Your maximum heart rate is estimated by subtracting your age from 220. For example, if you are 30 years old, your maximum heart rate is 190.) Heart rate program 1 is designed to keep your heart rate between 50% and 80% of your maximum heart rate while you exercise; heart rate program 2 is designed to keep your heart rate between 50% and 85% of your maximum heart rate.

Follow the steps below to use a heart rate program.

**1 Press any button on the console or begin pedaling to turn on the console.**

See step 1 on page 12.

**2 Select one of the heart rate programs.**

When the power is turned on, the manual mode will be selected. To select a heart rate program, press the Program Select button repeatedly until an "H 1" or "H 2" appears in the right display.

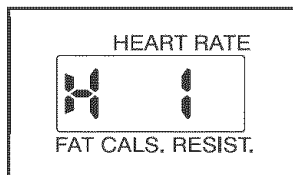

During heart rate programs, the matrix will show a moving graphic that represents your heart rate. Each time a heart-beat is detected, an additional peak will appear.

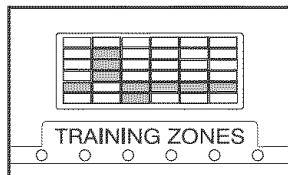

**3 Enter your age.**

When a heart rate program is selected, the word "AGE" and the current age setting will flash in the left display. You must enter your age to use a heart rate program. If you have already entered your age, press the Enter button and go to step 4. If you have not entered your age, press the + or - button repeatedly to enter your age, and then press the Enter button. Once you have entered your age, it will be saved in memory.

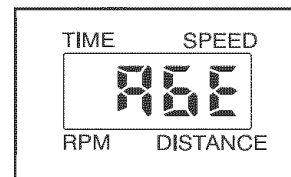

**4 Hold the handgrip pulse sensor.**

To use a heart rate program, you must use the handgrip pulse sensor (see step 5 on page 10) or the optional chest pulse sensor. If you use the handgrip pulse sensor, it is not necessary to hold the handgrips continuously during the program. However, you should hold the handgrips frequently for the program to operate properly. **Each time you hold the handgrips, keep your hands on the metal contacts for at least 30 seconds.** Note: When you are not holding the handgrips, the letters "PLS" will appear in the right display instead of your heart rate.

**5 Press the Program Start button or begin pedaling to start the program.**

When the program is started, the exercise cycle will automatically adjust to the resistance setting for the first segment.

Each program is divided into 20 one-minute segments. One resistance setting and one target heart rate setting are programmed for each segment. Note: The same resistance setting and/or target heart rate setting may be programmed for two or more consecutive segments.

During the last three seconds of each segment, a series of tones will sound. The resistance of the exercise cycle will then automatically change if a different resistance setting is programmed for the next segment.

As you exercise, the Training Zone bar will help you to keep your heart rate near the target heart

rate setting for the current segment. The lit indicators in the bar will show your actual pace. When you hold the handgrip pulse sensor or wear the optional chest pulse sensor, the console will periodically compare your heart rate to the

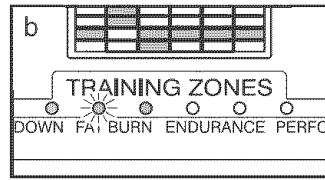
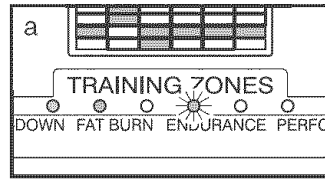

target heart rate setting for the current segment; if necessary, an indicator in the bar will then flash to prompt you to increase or decrease your pace to bring your heart rate closer to the target heart rate setting. If an indicator to the *right* of the lit indicators is flashing (see drawing a), increase your pace. If an indicator to the *left* of any lit indicator is flashing (see drawing b), decrease your pace. When no indicator is flashing, your heart rate is near the target heart rate setting.

**Important: The target heart rate settings are intended only to provide motivation. Your actual heart rate may be slower than the target heart rate settings. Make sure to exercise at a pace that is comfortable for you.**

Note: During the program, you can override the resistance setting, if desired, by pressing the Resistance buttons. However, when the next segment begins, the resistance will change if a different resistance setting is programmed for the next segment.

The program will continue until the last segment ends.

If you stop pedaling for several seconds, a tone will sound and the program will end. Heart rate programs cannot be stopped temporarily and then restarted.

**6 Monitor your progress with the two displays.**

See step 4 on page 12.

**7 Turn on the fan if desired.**

See step 6 on page 13.

**8 When the program is finished, the console will automatically turn off.**

See step 7 on page 13.



## HOW TO CONNECT YOUR CD PLAYER, VCR, OR COMPUTER

To use **iFIT.com** CDs, the exercise cycle must be connected to your portable CD player, portable stereo, home stereo, or computer with CD player. See pages 17 and 18 for connecting instructions. To use **iFIT.com videocassettes**, the exercise cycle must be connected to your VCR. See page 19 for connecting instructions. To use **iFIT.com programs directly from our Web site**, the exercise cycle must be connected to your home computer. See page 18 for connecting instructions.

## HOW TO CONNECT YOUR PORTABLE CD PLAYER

**Note:** If your CD player has separate **LINE OUT** and **PHONES** jacks, see instruction A below. If your CD player has only one jack, see instruction B.

- A. Plug one end of the audio cable into the jack beneath the console. Plug the other end of the cable into the **LINE OUT** jack on your CD player. Plug your headphones into the **PHONES** jack.

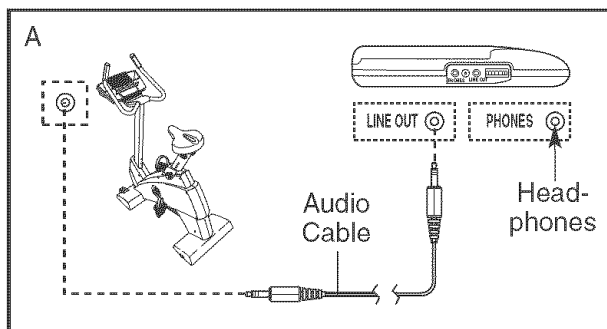

- B. Plug one end of the audio cable into the jack beneath the console. Plug the other end of the cable into a 1/8" Y-adapter (available at electronics stores). Plug the Y-adapter into the **PHONES** jack on your CD player. Plug your headphones into the other side of the Y-adapter.

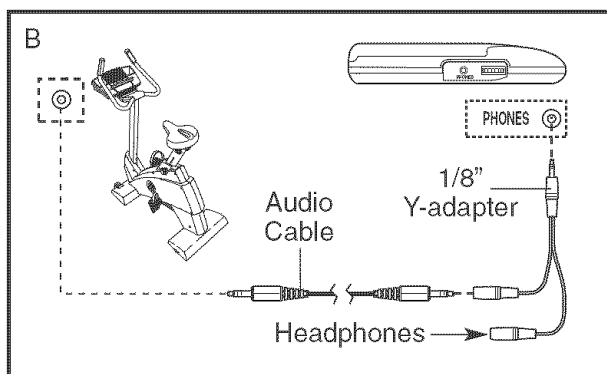

## HOW TO CONNECT YOUR PORTABLE STEREO

**Note:** If your stereo has an **RCA-type AUDIO OUT** jack, see instruction A below. If your stereo has a 1/8" **LINE OUT** jack, see instruction B. If your stereo has only a **PHONES** jack, see instruction C.

- A. Plug one end of the audio cable into the jack beneath the console. Plug the other end of the cable into the adapter. Plug the adapter into an **AUDIO OUT** jack on your stereo.

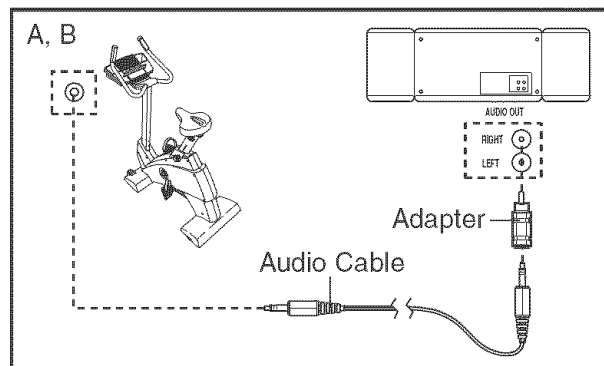

- B. Plug one end of the audio cable into the jack beneath the console. Plug the other end of the cable into the **LINE OUT** jack on your stereo. Do not use the adapter.

- C. Plug one end of the audio cable into the jack beneath the console. Plug the other end of the cable into a 1/8" Y-adapter (available at electronics stores). Plug the Y-adapter into the **PHONES** jack on your stereo. Plug your headphones into the other side of the Y-adapter.

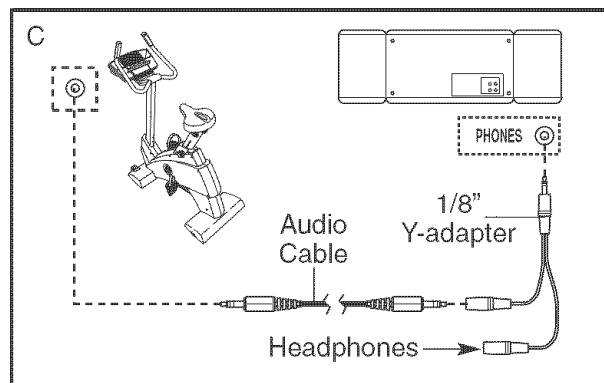

## HOW TO CONNECT YOUR HOME STEREO

**Note:** If your stereo has an unused **LINE OUT** jack, see instruction **A** below. If the **LINE OUT** jack is being used, see instruction **B**.

- A.** Plug one end of the audio cable into the jack beneath the console. Plug the other end of the cable into the adapter. Plug the adapter into the **LINE OUT** jack on your stereo.

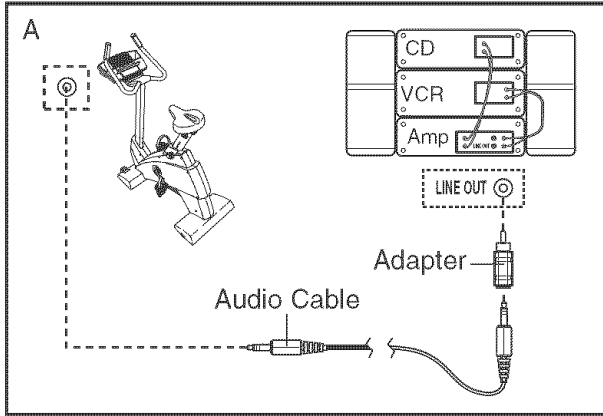

- B.** Plug one end of the audio cable into the jack beneath the console. Plug the other end of the cable into the adapter. Plug the adapter into an **RCA Y-adapter** (available at electronics stores). Next, remove the wire that is currently plugged into the **LINE OUT** jack on your stereo and plug the wire into the unused side of the Y-adapter. Plug the Y-adapter into the **LINE OUT** jack on your stereo.

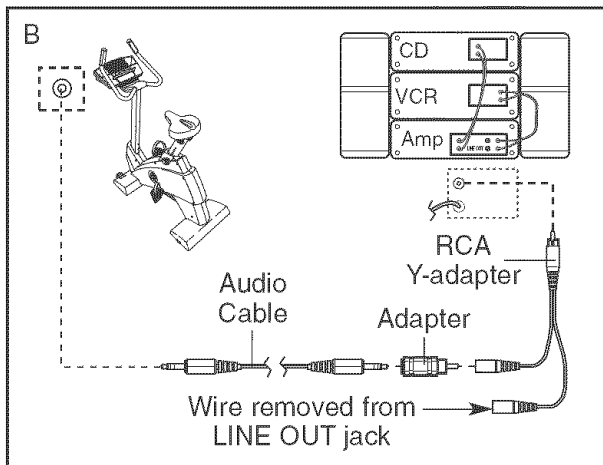

## HOW TO CONNECT YOUR COMPUTER

**Note:** If your computer has a **1/8" LINE OUT** jack, see instruction **A**. If your computer has only a **PHONES** jack, see instruction **B**.

- A.** Plug one end of the audio cable into the jack beneath the console. Plug the other end of the cable into the **LINE OUT** jack on your computer.

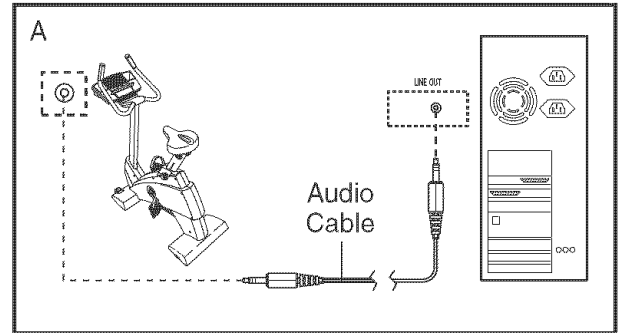

- B.** Plug one end of the audio cable into the jack beneath the console. Plug the other end of the cable into a **1/8" Y-adapter** (available at electronics stores). Plug the Y-adapter into the **PHONES** jack on your computer. Plug your headphones or speakers into the other side of the Y-adapter.

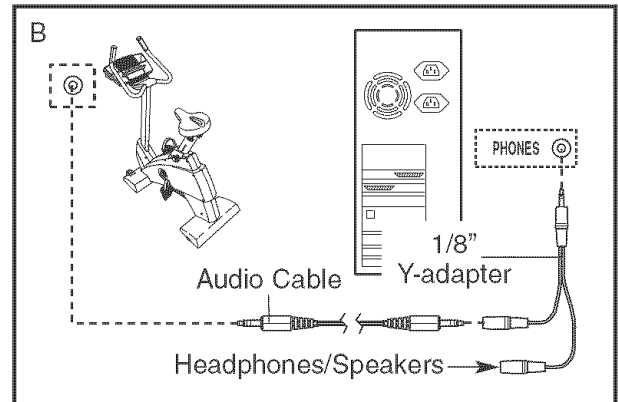

## HOW TO CONNECT YOUR VCR

**Note:** If your VCR has an unused AUDIO OUT jack, see instruction A below. If the AUDIO OUT jack is being used, see instruction B. If you have a TV with a built-in VCR, see instruction B. If your VCR is connected to your home stereo, see HOW TO CONNECT YOUR HOME STEREO on page 18.

- A. Plug one end of the audio cable into the jack beneath the console. Plug the other end of the cable into the adapter. Plug the adapter into the AUDIO OUT jack on your VCR.

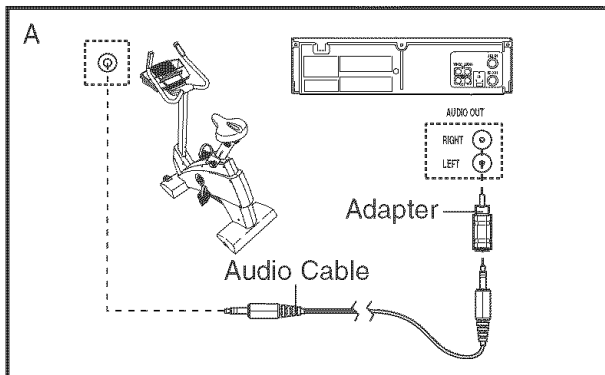

- B. Plug one end of the audio cable into the jack beneath the console. Plug the other end of the cable into the adapter. Plug the adapter into an RCA Y-adapter (available at electronics stores). Next, remove the wire that is currently plugged into the AUDIO OUT jack on your VCR and plug the wire into the unused side of the Y-adapter. Plug the Y-adapter into the AUDIO OUT jack on your VCR.

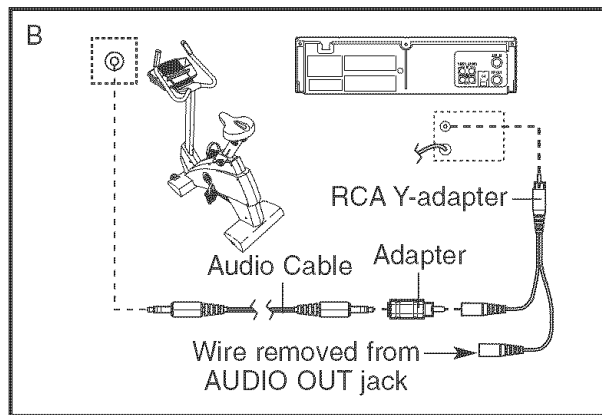

## HOW TO USE iFIT.COM CD AND VIDEO PROGRAMS

To use iFIT.com CDs or videocassettes, the exercise cycle must be connected to your portable CD player, portable stereo, home stereo, computer with CD player, or VCR. See HOW TO CONNECT YOUR CD PLAYER, VCR, OR COMPUTER on page 17. **To purchase iFIT.com CDs and videocassettes, call toll-free 1-800-735-0768.**

Follow the steps below to use an iFIT.com CD or video program.

### **1** Begin pedaling to activate the console.

See step 1 on page 12.

### **2** Select the iFIT.com mode.

When the console is turned on, the manual mode will be selected. To select the iFIT.com mode, press the iFIT.com button.

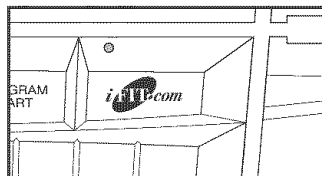

The indicator above the button will light.

### **3** Insert the iFIT.com CD or videocassette.

If you are using an iFIT.com CD, insert the CD into your CD player. If you are using an iFIT.com videocassette, insert the videocassette into your VCR.

### **4** Press the play button on your CD player or VCR.

A moment after the play button is pressed, your personal trainer will begin guiding you through

your workout. Simply follow your personal trainer's instructions.

The program will function in almost the same way as a resistance and pace program (see step 3 on page 14). However, an electronic "chirping" sound will alert you when the resistance setting and/or the pace setting is about to change.

**Note: If the resistance of the exercise cycle and/or the pace setting does not change when a "chirp" is heard:**

- Make sure that the indicator above the iFIT.com button is lit.
- Adjust the volume of your CD player or VCR. If the volume is too high or too low, the console may not detect the program signals.
- Make sure that the audio cable is properly connected and that it is fully plugged in.

### **5** Monitor your progress with the two displays.

See step 4 on page 12.

### **6** Measure your heart rate if desired.

See step 5 on page 13.

### **7** Turn on the fan if desired.

See step 6 on page 13.

### **8** When the program is finished, the console will automatically turn off.

See step 7 on page 13.

## HOW TO USE PROGRAMS DIRECTLY FROM OUR WEB SITE

Our Web site at [www.iFIT.com](http://www.iFIT.com) allows you to play iFIT.com audio and video programs directly from the internet. To use programs from our Web site, the exercise cycle must be connected to your home computer. See HOW TO CONNECT YOUR COMPUTER on page 18. In addition, you must have an internet connection and an internet service provider. A list of specific system requirements will be found on our Web site.

Follow the steps below to use a program from our Web site.

### 1 Begin pedaling to activate the console.

See step 1 on page 12.

### 2 Select the iFIT.com mode.

When the console is turned on, the manual mode will be selected. To select the iFIT.com mode, press the iFIT.com button.

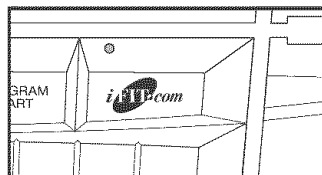

The indicator above the button will light.

### 3 Go to your computer and start an internet connection.

### 4 Start your Web browser, if necessary, and go to our Web site at [www.iFIT.com](http://www.iFIT.com).

### 5 Follow the desired links on our Web site to select a program.

Read and follow the on-line instructions for using a program.

### 6 Follow the on-line instructions to start the program.

When you start the program, an on-screen countdown will begin.

### 7 Return to the exercise cycle and begin pedaling.

When the on-screen countdown ends, the program will begin. The program will function in almost the same way as a resistance and pace program (see step 3 on page 14). However, an electronic “chirping” sound will alert you when the resistance setting and/or the pace setting is about to change.

### 8 Monitor your progress with the two displays.

See step 4 on page 12.

### 9 Measure your heart rate if desired.

See step 5 on page 13.

### 10 Turn on the fan if desired.

See step 6 on page 13.

### 11 When you are finished exercising, the console will automatically turn off.

See step 7 on page 13.

## THE OPTIONAL CHEST PULSE SENSOR

The optional chest pulse sensor provides hands-free operation and continuously monitors your heart rate during your workouts. To purchase the optional chest pulse sensor, call toll-free 1-800-734-2377.

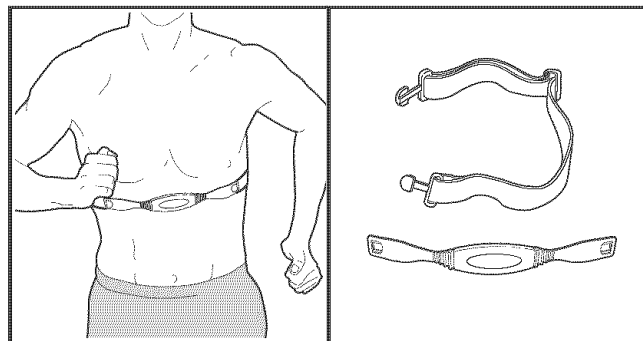

# MAINTENANCE AND TROUBLESHOOTING

Inspect and properly tighten all parts of the exercise cycle regularly. To clean the exercise cycle, use a soft, damp cloth. Keep liquids away from the console and keep the console out of direct sunlight.

## HOW TO ADJUST THE REED SWITCH

If the console does not display correct feedback, the reed switch should be adjusted. To adjust the reed switch, the right side shield must first be removed. Remove the indicated M4 x 25mm Screws (65) from the Left Side Shield (26).

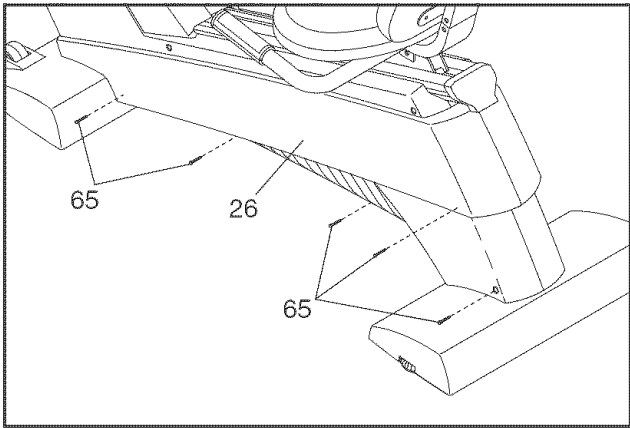

Next, remove the indicated M5 x 25mm Screw (93) and M4 x 16mm Screws (57) from the Right Side Shield (27). Using an adjustable wrench, turn the Right Pedal (21) counterclockwise and remove it. Turn the Right Crank Arm (23) so that it is pointing toward the front of the exercise cycle, and then slide off the Right Side Shield.

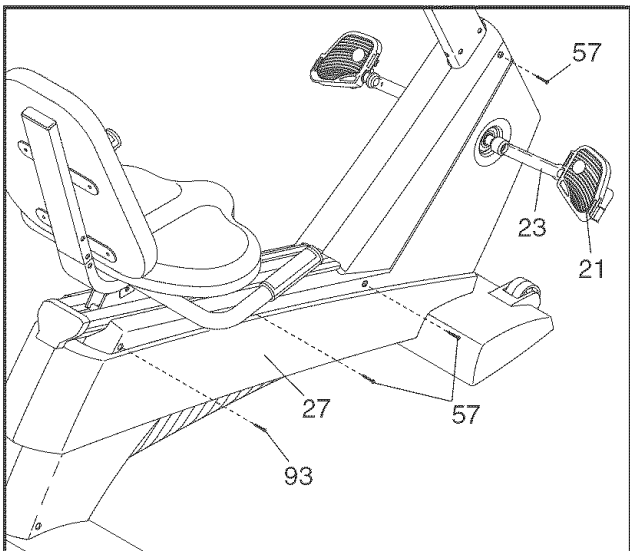

Locate the Reed Switch (46). Turn the Right Crank Arm (23) until the Magnet (30) is aligned with the Reed Switch. Loosen, but do not remove, the indicated M4 x 16mm Screw (57). Slide the Reed Switch slightly closer to or away from the Magnet. Then, retighten the Screw. Turn the Right Crank Arm for a moment. Repeat until the console displays correct feedback. When the Reed Switch is correctly adjusted, reattach the right side shield and the right pedal.

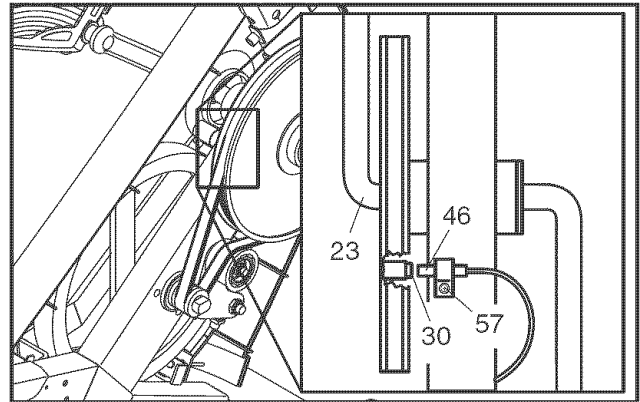

## HOW TO ADJUST THE DRIVE BELT

If you can feel the pedals slip while you are pedaling, even when the resistance is adjusted to the highest level, the Drive Belt (47) may need to be adjusted. To adjust the Drive Belt, you must first remove the right side shield. See HOW TO ADJUST THE REED SWITCH at the left and remove the right side shield.

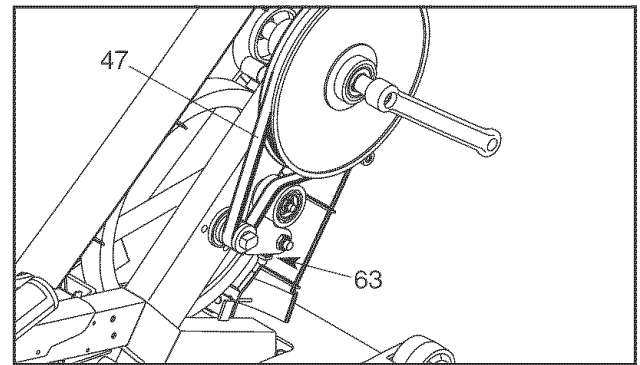

Next, turn the indicated M10 Nylon Locknut (63) until the Drive Belt (47) is properly tightened. Then, reattach the right side shield.

## PULSE SENSOR TROUBLESHOOTING

If the handgrip pulse sensor does not function properly, see step 5 on page 13.

# EXERCISE GUIDELINES

## ▲ WARNING:

- Before beginning this or any exercise program, consult your physician. This is especially important for individuals over the age of 35 or individuals with pre-existing health problems.
- The pulse sensor is not a medical device. Various factors may affect the accuracy of heart rate readings. The pulse sensor is intended only as an exercise aid in determining heart rate trends in general.

The following guidelines will help you to plan your exercise program. Remember that proper nutrition and adequate rest are essential for successful results.

### EXERCISE INTENSITY

Whether your goal is to burn fat or to strengthen your cardiovascular system, the key to achieving the desired results is to exercise with the proper intensity. The proper intensity level can be found by using your heart rate as a guide. The chart below shows recommended heart rates for fat burning, maximum fat burning, and cardiovascular (aerobic) exercise.

165	155	145	140	130	125	115	♥
145	138	130	125	118	110	103	♥
125	120	115	110	105	95	90	♥
<hr/>							
20	30	40	50	60	70	80	

To find the proper heart rate for you, first find your age at the bottom of the chart (ages are rounded off to the nearest ten years). Next, find the three numbers above your age; the three numbers are your “training zone.” The lowest number is the recommended heart rate for fat burning; the middle number is the recommended heart rate for maximum fat burning; and the highest number is the heart rate for aerobic exercise.

### Fat Burning

To burn fat effectively, you must exercise at a relatively low intensity level for a sustained period of time. During the first few minutes of exercise, your body uses easily accessible *carbohydrate* calories for energy. Only after the first few minutes of exercise does your body begin to use stored *fat* calories for energy. If your goal is to burn fat, adjust the intensity of your exercise until your heart rate is near the lowest number or the middle number in your training zone as you exercise.

### Aerobic Exercise

If your goal is to strengthen your cardiovascular system, your exercise must be “aerobic.” Aerobic exercise is activity that requires large amounts of oxygen for prolonged periods of time. This increases the demand on the heart to pump blood to the muscles, and on the lungs to oxygenate the blood. For aerobic exercise, adjust the intensity of your exercise until your heart rate is near the highest number in your training zone.

### WORKOUT GUIDELINES

Each workout should include the following three parts:

**A warm-up**, consisting of 5 to 10 minutes of stretching and light exercise. A proper warm-up increases your body temperature, heart rate, and circulation in preparation for exercise.

**Training zone exercise**, consisting of 20 to 30 minutes of exercising with your heart rate in your training zone. (During the first few weeks of your exercise program, do not keep your heart rate in your training zone for longer than 20 minutes.)

**A cool-down**, with 5 to 10 minutes of stretching. This will increase the flexibility of your muscles and will help to prevent post-exercise problems.

### EXERCISE FREQUENCY

To maintain or improve your condition, plan three workouts each week, with at least one day of rest between workouts. After a few months of regular exercise, you may complete up to five workouts each week, if desired. The key to success is make exercise a regular and enjoyable part of your everyday life.

## SUGGESTED STRETCHES

The correct form for several basic stretches is shown at the right. Move slowly as you stretch—never bounce.

### 1. Toe Touch Stretch

Stand with your knees bent slightly and slowly bend forward from your hips. Allow your back and shoulders to relax as you reach down toward your toes as far as possible. Hold for 15 counts, then relax. Repeat 3 times. Stretches: Hamstrings, back of knees and back.

### 2. Hamstring Stretch

Sit with one leg extended. Bring the sole of the opposite foot toward you and rest it against the inner thigh of your extended leg. Reach toward your toes as far as possible. Hold for 15 counts, then relax. Repeat 3 times for each leg. Stretches: Hamstrings, lower back and groin.

### 3. Calf/Achilles Stretch

With one leg in front of the other, reach forward and place your hands against a wall. Keep your back leg straight and your back foot flat on the floor. Bend your front leg, lean forward and move your hips toward the wall. Hold for 15 counts, then relax. Repeat 3 times for each leg. To cause further stretching of the achilles tendons, bend your back leg as well. Stretches: Calves, achilles tendons and ankles.

### 4. Quadriceps Stretch

With one hand against a wall for balance, reach back and grasp one foot with your other hand. Bring your heel as close to your buttocks as possible. Hold for 15 counts, then relax. Repeat 3 times for each leg. Stretches: Quadriceps and hip muscles.

### 5. Inner Thigh Stretch

Sit with the soles of your feet together and your knees outward. Pull your feet toward your groin area as far as possible. Hold for 15 counts, then relax. Repeat 3 times. Stretches: Quadriceps and hip muscles.

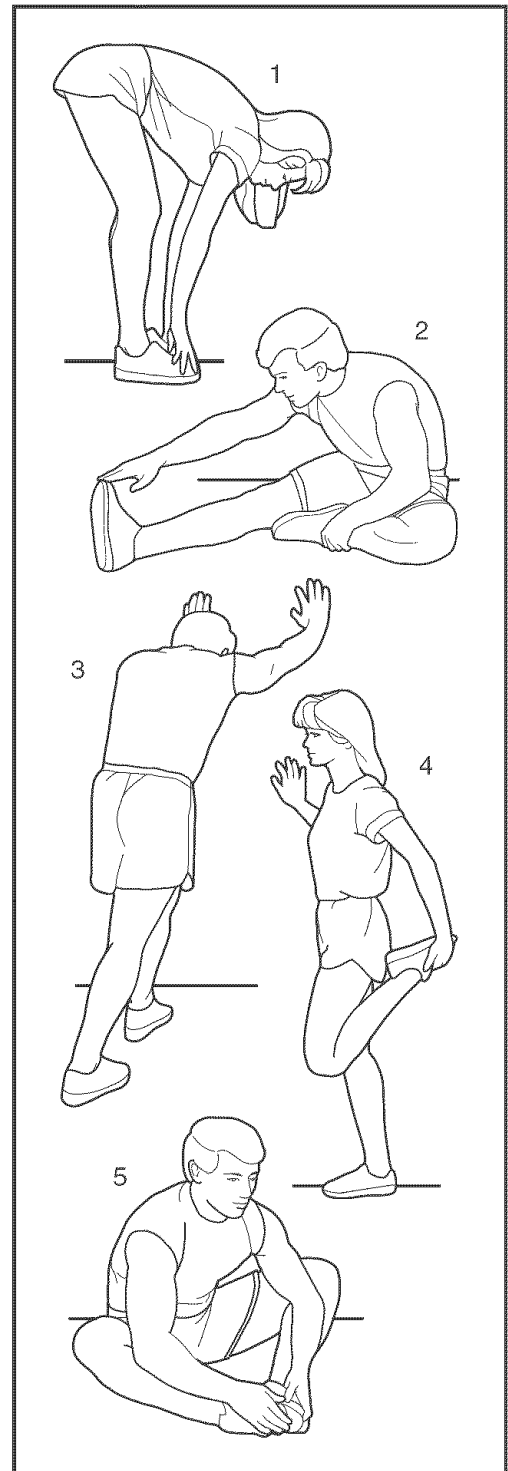



# PART LIST—Model No. NTC07940

R1203A

Key No.	Qty.	Description	Key No.	Qty.	Description
1	1	Frame	52	1	Seat Carriage Endcap
2	1	Upright	53	2	Bolt Set
3	1	Pulse Wire	54	8	M8 x 40mm Button Screw
4	1	Console	55	12	M8 Split Washer
5	1	Seat Rail	56	8	M4 x 38mm Screw
6	2	Pulse Sensor/Wire	57	10	M4 x 16mm Screw
7	1	Seat Frame	58	4	Carriage Bushing
8	1	Seat Rail Endcap	59	2	M6 x 50mm Button Bolt
9	1	Seat	60	5	M6 Washer
10	1	Seat Knob	61	1	M10 Washer
11	1	Seat Carriage	62	1	Backrest
12	1	Seat Frame Endcap	63	5	M10 Nylon Locknut
13	1	Front Stabilizer Cover	64	4	M5 Nylon Locknut
14	1	Rear Stabilizer Cover	65	6	M4 x 25mm Screw
15	1	Front Stabilizer	66	1	Backrest Frame Endcap
16	1	Rear Stabilizer	67	1	Idler Bolt
17	2	Wheel	68	4	M6 x 18mm Bolt
18	1	Right Pedal Strap	69	2	M5 Nut
19	4	Leveling Foot	70	1	Left Handlebar
20	6	M6 x 20mm Button Screw	71	6	M5 Washer
21	1	Right Pedal	72	1	Right Handlebar
22	1	Left Pedal	73	2	Handlebar Endcap
23	1	Right Crank Arm	74	4	M5 x 16mm Bolt
24	1	Left Crank Arm	75	6	M5 x 16mm Screw
25	1	Left Pedal Strap	76	1	M10 x 43mm Bolt
26	1	Left Side Shield	77	3	M8 x 35mm Screw
27	1	Right Side Shield	78	2	M10 x 118mm Button Screw
28	2	Snap Ring	79	4	M8 x 25mm Button Screw
29	1	Pulley	80	1	M6 x 45mm Button Screw
30	1	Magnet	81	4	M8 x 40mm Button Bolt
31	1	Crank Assembly	82	2	M10 x 52mm Button Bolt
32	2	Pulley Spacer	83	12	M6 Nylon Locknut
33	4	Crank Bearing	84	2	Bumper
34	1	Flywheel	85	1	“J” Bolt Bushing
35	1	“C” Magnet	86	2	Foam Grip
36	1	Resistance Cable	87	2	M6 Nut
37	1	Spring	88	2	M10 Split Washer
38	1	Resistance Motor	89	5	M8 Nylon Locknut
39	1	Idler Arm	90	2	Handlebar Foam
40	1	Thrust Washer	91	1	M6 x 45mm Button Bolt
41	1	M4 Push Nut	92	1	M10 Flange Nut
42	1	Backrest Frame	93	2	M5 x 25mm Screw
43	1	Lower Wire Harness	94	2	M6 x 18mm Socket Bolt
44	1	Flywheel Bracket	95	1	M10 Nylon Jam Nut
45	1	Clamp	96	1	M6 x 38mm Bolt
46	1	Reed Switch/Wire	97	1	Upper Wire Harness
47	1	Drive Belt	98	1	Seat Back
48	1	Flywheel Axle	99	2	Upright Spacer
49	1	M10 x 82mm Bolt	#	3	Allen Wrench
50	2	Flange Screw	#	1	User's Manual
51	2	M4 Washer			

Note: “#” indicates a non-illustrated part. Specifications are subject to change without notice. See the back cover of this manual for information about ordering replacement parts.

# EXPLODED DRAWING—Model No. NTC07940

R1203A

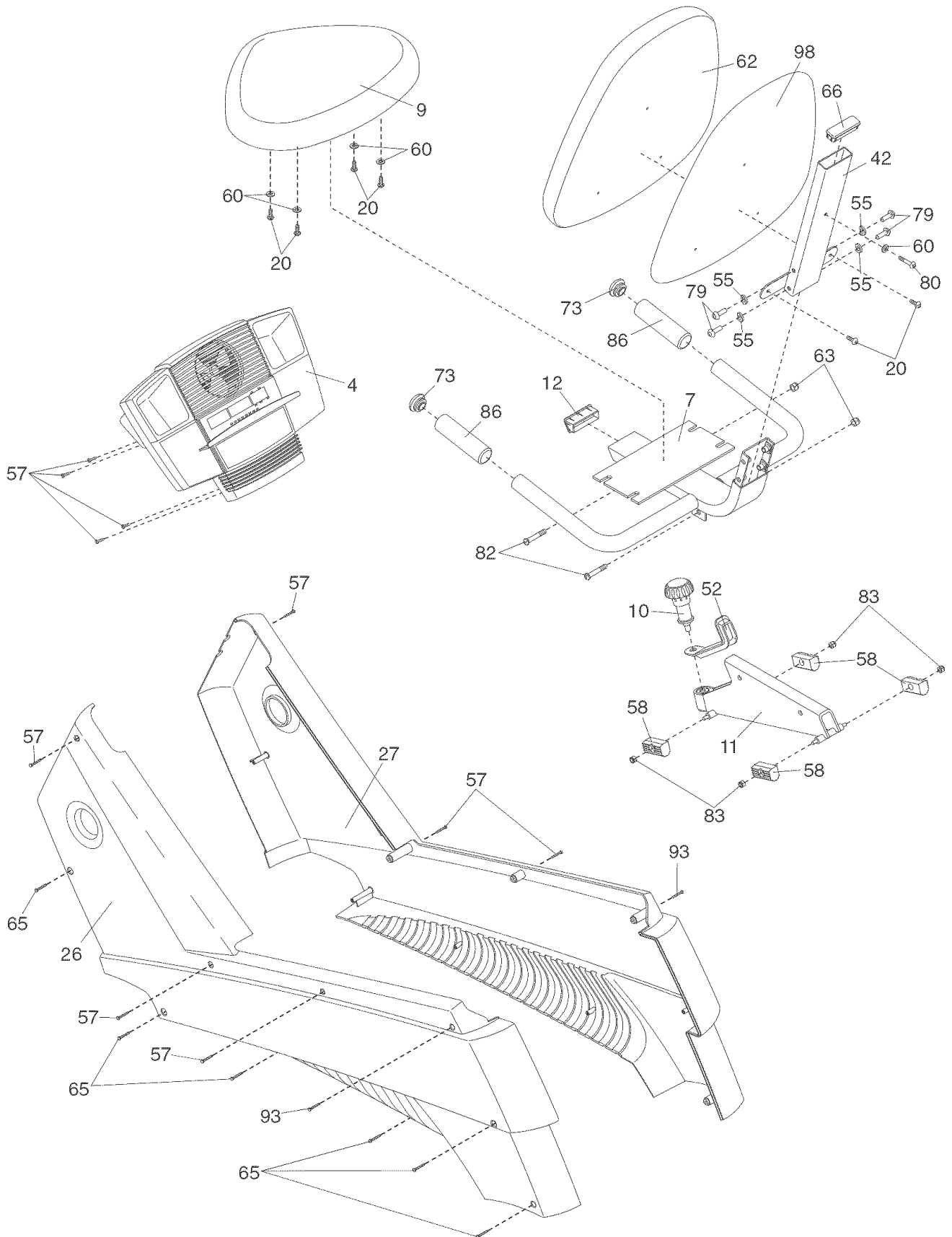

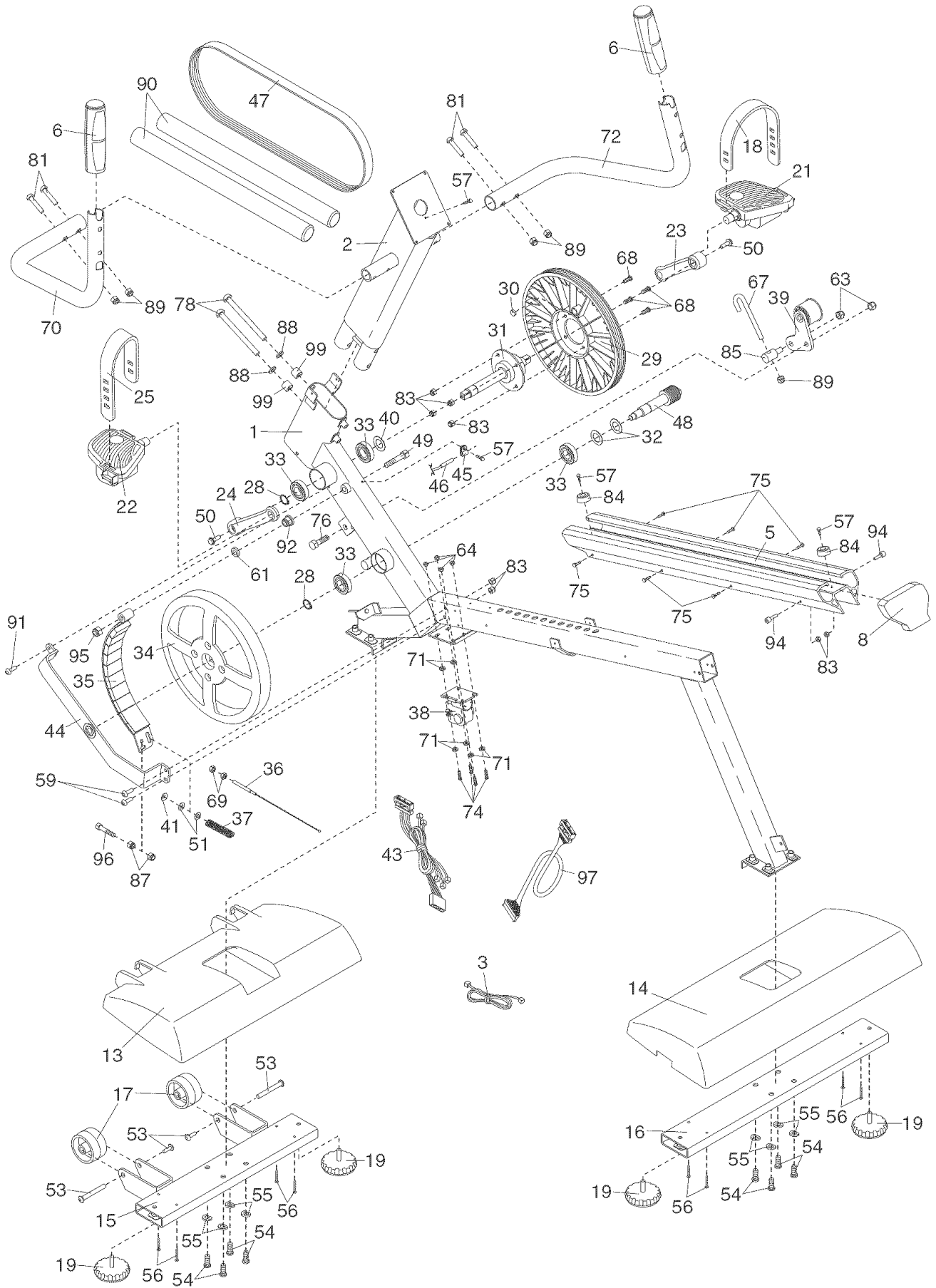

NTC07940 R1203A

# HOW TO ORDER REPLACEMENT PARTS

To order replacement parts, simply call our Customer Service Department toll-free at 1-888-825-2588, Monday through Friday, 6 a.m. until 6 p.m. Mountain Time (excluding holidays). To help us assist you, please be prepared to give the following information when calling:

- the MODEL NUMBER of the product (NTC07940)
- the NAME of the product (NordicTrack® SL 710 exercise cycle)
- the SERIAL NUMBER of the product (see the front cover of this manual)
- the KEY NUMBER and DESCRIPTION of the part(s) (see pages 25, 26, and 27)

## LIMITED WARRANTY

**WHAT IS COVERED**—The entire NordicTrack® SL 710 exercise cycle (“Product”) is warranted to be free of all defects in material and workmanship.

**WHO IS COVERED**—The original purchaser or any person receiving the Product as a gift from the original purchaser.

**HOW LONG IS IT COVERED**—ICON Health & Fitness, Inc. (“ICON”), warrants the product for one year after the date of purchase. Labor is covered for one year.

**WHAT WE DO TO CORRECT COVERED DEFECTS**—We will ship to you, without charge, any replacement part or component, providing the repairs are authorized by ICON first and are performed by an ICON trained and authorized service provider, or, at our option, we will replace the Product.

**WHAT IS NOT COVERED**—Any failures or damage caused by unauthorized service, misuse, accident, negligence, improper assembly or installation, alterations, modifications without our written authorization or by failure on your part to use, operate, and maintain as set out in your User’s Manual (“Manual”).

**WHAT YOU MUST DO**—Always retain proof of purchase, such as your bill of sale; store, operate, and maintain the Product as specified in the Manual; notify our Customer Service Department of any defect within 10 days after discovery of the defect; as instructed, return any defected part for replacement or, if necessary, the entire product, for repair.

**USER’S MANUAL**—It is VERY IMPORTANT THAT YOU READ THE MANUAL before operating the Product. Remember to do the periodic maintenance requirements specified in the Manual to assure proper operation and your continued satisfaction.

**HOW TO GET PARTS AND SERVICE**—Simply call our Customer Service Department at 1-888-825-2588 and tell them your name and address and the serial number of your Product. They will tell you how to get a part replaced, or if necessary, arrange for service where your Product is located or advise you how to ship the Product for service. Before shipping, always obtain a Return Authorization Number (RA No.) from our Customer Service Department; securely pack your Product (save the original shipping carton if possible); put the RA No. on the outside of the carton and insure the product. Include a letter explaining the product or problem and a copy of your proof of purchase if you believe the service is covered by warranty.

ICON is not responsible or liable for indirect, special or consequential damages arising out of or in connection with the use or performance of the product or damages with respect to any economic loss, loss of property, loss of revenues or profits, loss of enjoyment or use, costs of removal, installation or other consequential damages of whatsoever nature. Some states do not allow the exclusion or limitation of incidental or consequential damages. Accordingly, the above limitation may not apply to you.

The warranty extended hereunder is in lieu of any and all other warranties and any implied warranties of merchantability or fitness for a particular purpose is limited in its scope and duration to the terms set forth herein. Some states do not allow limitations on how long an implied warranty lasts. Accordingly, the above limitation may not apply to you.

No one is authorized to change, modify or extend the terms of this limited warranty. This warranty gives you specific legal rights and you may have other rights which vary from state to state.

**ICON HEALTH & FITNESS, INC., 1500 S. 1000 W., LOGAN, UT 84321-9813**