

# **NordicTrack**<sup>®</sup> *CXT 980*

Model No. 831.298651

Serial No. \_\_\_\_\_

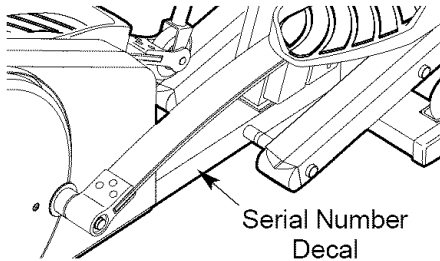

## USER'S MANUAL

### QUESTIONS?

If you have questions, or if there are missing parts, we will guarantee complete satisfaction through direct assistance from our factory.

TO AVOID UNNECESSARY DELAYS, PLEASE CALL DIRECT TO OUR TOLL-FREE CUSTOMER HOT LINE. The trained technicians on our customer hot line will provide immediate assistance, free of charge to you.

CUSTOMER HOT LINE:

**1-888-825-2588**

Mon.–Fri., 6 a.m.–6 p.m. MST

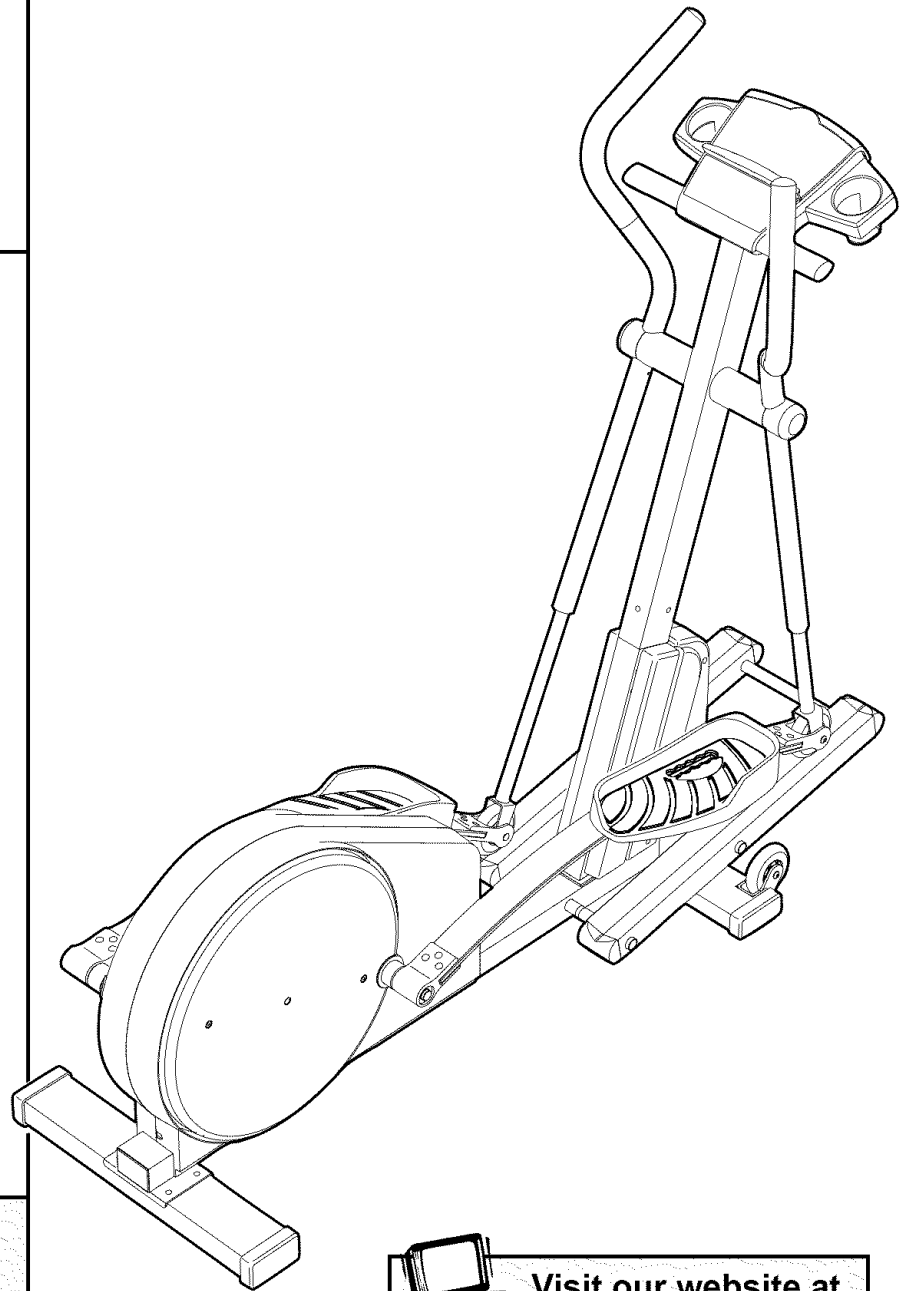

### CAUTION

Read all precautions and instructions in this manual before using this equipment. Keep this manual for future reference.



Visit our website at

[www.nordictrack.com](http://www.nordictrack.com)

*new products, prizes,  
fitness tips, and much more!*



---

## TABLE OF CONTENTS

IMPORTANT PRECAUTIONS .....	3
BEFORE YOU BEGIN .....	4
ASSEMBLY .....	5
HOW TO USE THE ELLIPTICAL CROSSTRAINER .....	8
MAINTENANCE AND TROUBLESHOOTING .....	20
CONDITIONING GUIDELINES .....	21
PART LIST .....	22
EXPLODED DRAWING .....	23
HOW TO ORDER REPLACEMENT PARTS .....	Back Cover
LIMITED WARRANTY .....	Back Cover

# IMPORTANT PRECAUTIONS

**⚠ WARNING:** To reduce the risk of serious injury, read the following important precautions before using the elliptical crosstrainer.

1. Read all instructions in this manual before using the elliptical crosstrainer.
2. It is the responsibility of the owner to ensure that all users of the elliptical crosstrainer are adequately informed of all precautions.
3. The elliptical crosstrainer is intended for in-home use only. Do not use the elliptical crosstrainer in a commercial, rental, or institutional setting.
4. Place the elliptical crosstrainer on a level surface, with a mat beneath it to protect the floor or carpet. Keep the elliptical crosstrainer indoors, away from moisture and dust.
5. Inspect and properly tighten all parts regularly. Replace any worn parts immediately.
6. Keep children under age 12 and pets away from the elliptical crosstrainer at all times.
7. The elliptical crosstrainer should not be used by persons weighing more than 250 pounds.
8. Wear appropriate exercise clothing when using the elliptical crosstrainer. Always wear athletic shoes for foot protection.
9. Always hold the handlebar or the upper body arms when mounting, dismounting, or using the elliptical crosstrainer.
10. Keep your back straight when using the elliptical crosstrainer; do not arch your back.
11. If you feel pain or dizziness while exercising, stop immediately and cool down.
12. The pulse sensor is not a medical device. Various factors, including the user's movement, may affect the accuracy of heart rate readings. The pulse sensor is intended only as an exercise aid in determining heart rate trends in general.
13. When you stop exercising, allow the pedals to slowly come to a complete stop. The elliptical crosstrainer does not have a free wheel; the pedals will continue to move until the flywheel stops.
14. Always unplug the power cord immediately after use and before cleaning the elliptical crosstrainer.
15. The decal shown below has been placed on the elliptical crosstrainer. If the decal is missing or illegible, please call our Customer Service Department toll-free at 1-888-825-2588 to order a free replacement decal. Apply the decal in the location shown.

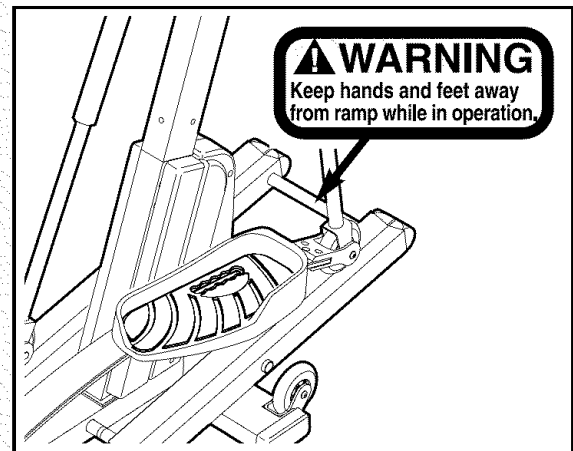

**⚠ WARNING:** Before beginning this or any exercise program, consult your physician. This is especially important for persons over the age of 35 or persons with pre-existing health problems. Read all instructions before using. SEARS assumes no responsibility for personal injury or property damage sustained by or through the use of this product.

# BEFORE YOU BEGIN

Congratulations for selecting the new NordicTrack® CXT 980 elliptical crosstrainer. The CXT 980 is an incredibly smooth exerciser that moves your feet in a natural elliptical path, minimizing the impact on your knees and ankles. And the unique CXT 980 features adjustable resistance and incline to help you get the most from your exercise. Welcome to a whole new world of natural, elliptical-motion exercise from NordicTrack.



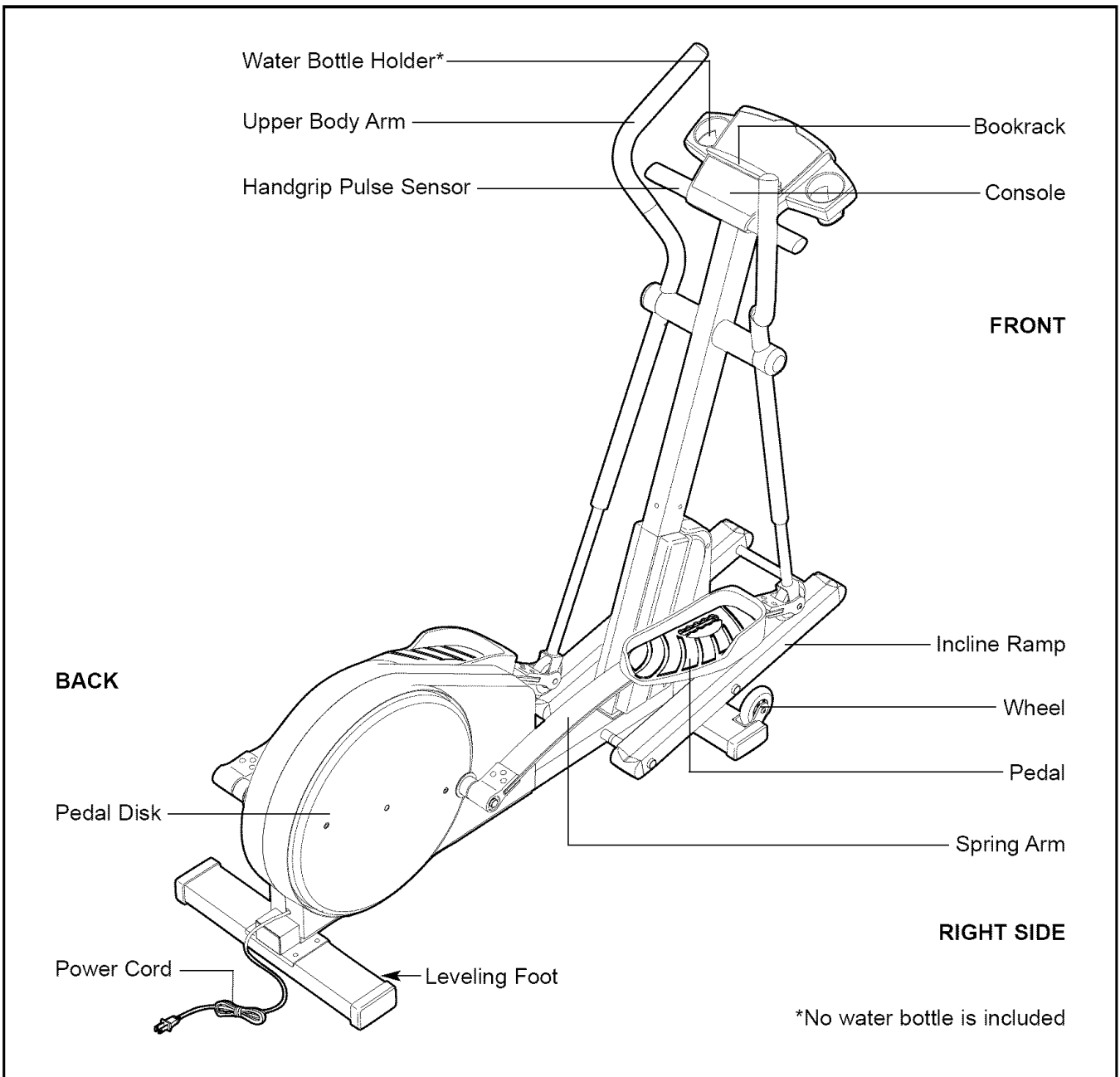

For additional questions, please call our Customer Service Department toll-free at 1-888-825-2588, Monday through Friday, 6 a.m. until 6 p.m. Mountain Time (excluding holidays). To help us assist you, please note the product model number and serial number before calling. The model number is 831.298651. The serial number can be found on a decal attached to the elliptical crosstrainer (see the front cover of this manual for the location of the decal).

**For your benefit, read this manual carefully before you use the elliptical crosstrainer.** If you have addi-

Before reading further, please familiarize yourself with the parts that are labeled in the drawing below.



# ASSEMBLY

**Assembly requires two people.** Place all parts of the elliptical crosstrainer in a cleared area and remove the packing materials. Do not dispose of the packing materials until assembly is completed. **In addition to the two included allen wrenches, assembly requires a phillips screwdriver** , **an adjustable wrench** , **a rubber mallet** , and **pliers** .

As you assemble the elliptical crosstrainer, use the drawings below to identify the small parts used in assembly. The number in parenthesis below each drawing refers to the key number of the part, from the PART LIST on page 22. The second number refers to the quantity used in assembly. **Note: Some small parts may have been pre-attached for shipping. If a part is not in the parts bag, check to see if it has been pre-assembled.**

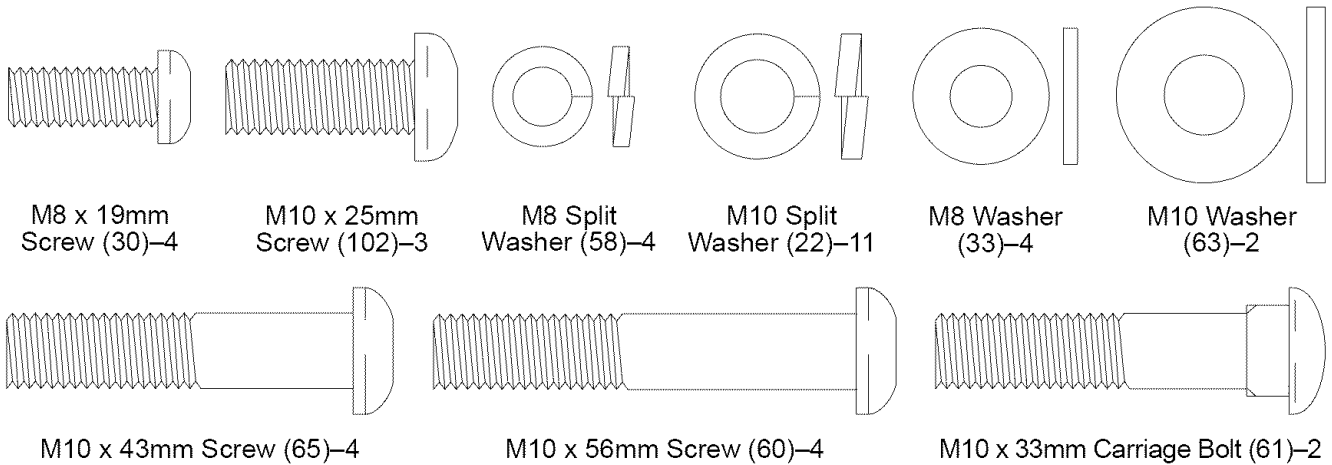

1. Identify the Rear Stabilizer (59), which has Leveling Feet (14) threaded into it. Attach the Rear Stabilizer to the Frame with the four M10 x 56mm Screws (60) and four M10 Split Washers (22).

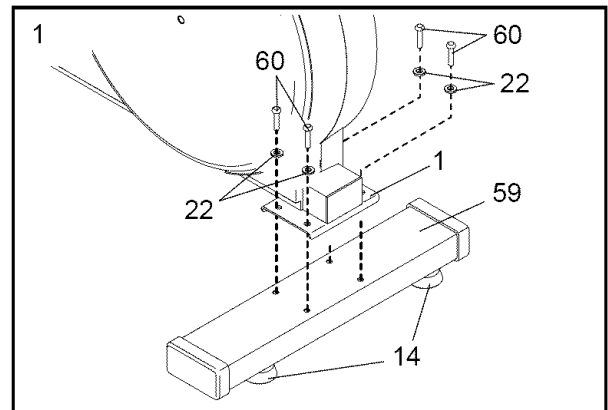

2. Attach the Front Stabilizer (90) to the Frame (1) with the four M10 x 43mm Screws (65) and four M10 Split Washers (22). **Make sure that the Front Stabilizer is turned so the Wheels (45) are not touching the floor.**

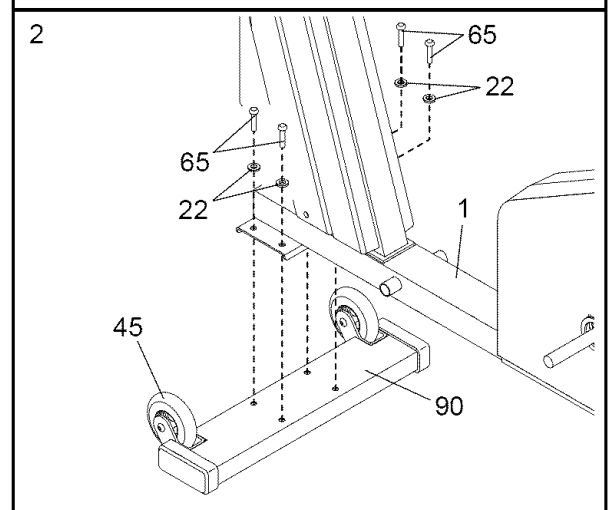

- Slide an M8 Split Washer (58) and an M8 Washer (33) onto an M8 x 19mm Screw (30). Tighten the Screw into one end of an Incline Axle (29). Next, apply a small amount of the included grease to the Incline Axle.

Align the indicated tubes on the Incline Ramp (5) with the tubes on the Frame (1). **Make sure that the Incline Ramp is turned so the V-shaped grooves are on top.** Insert the Incline Axle (29) into the Incline Ramp and the Frame. Note: It may be helpful to tap the Incline Axle with a rubber mallet to insert it.

Slide an M8 Split Washer (58) and an M8 Washer (33) onto another M8 x 19mm Screw (30). Tighten the Screw into the open end of the Incline Axle (29).

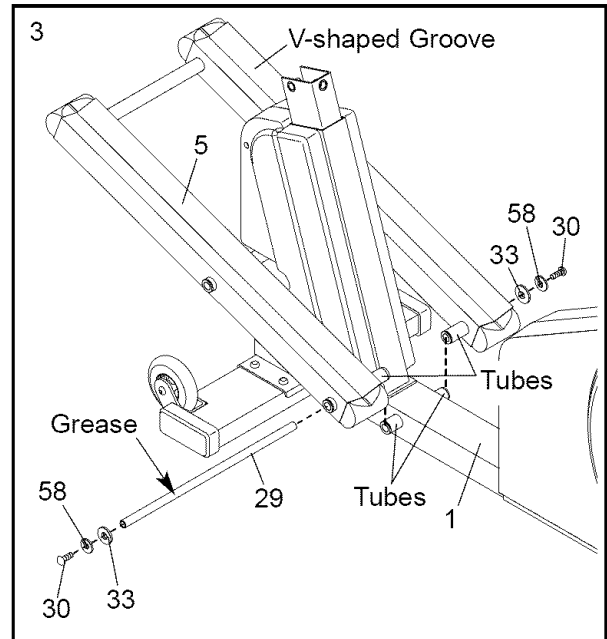

- Slide an M8 Split Washer (58) and an M8 Washer (33) onto an M8 x 19mm Screw (30). Tighten the Screw into one end of the other Incline Axle (29). Next, apply a small amount of grease to the Incline Axle.

Raise the Incline Ramp (5). Insert the Incline Axle (29) through one side of the Incline Ramp, through a 56mm Spacer (24), through the end of the motor screw, through another 56mm Spacer (24), and then through the other side of the Incline Ramp.

Slide an M8 Split Washer (58) and an M8 Washer (33) onto another M8 x 19mm Screw (30). Tighten the Screw into the open end of the Incline Axle (29).

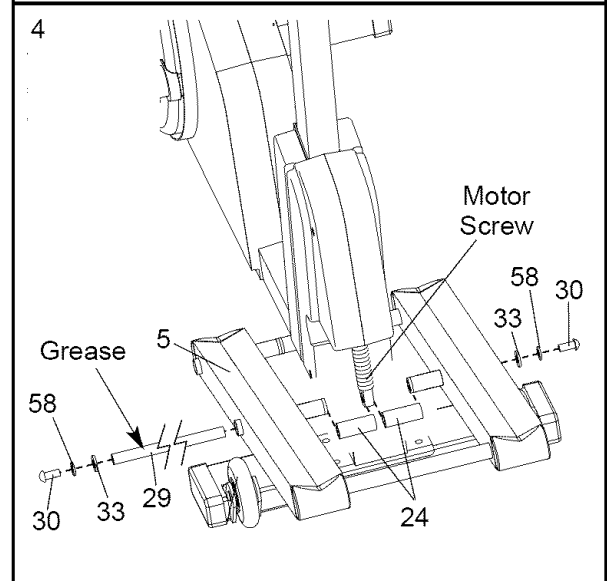

- While another person holds the Upright (2) near the Frame (1), connect the Wire Harness (85) to the Extension Wire Harness (51). Next, attach the Upright to the Frame with three M10 x 25mm Screws (102) and three M10 Split Washers (22). **Be careful to avoid pinching the wire harnesses.**

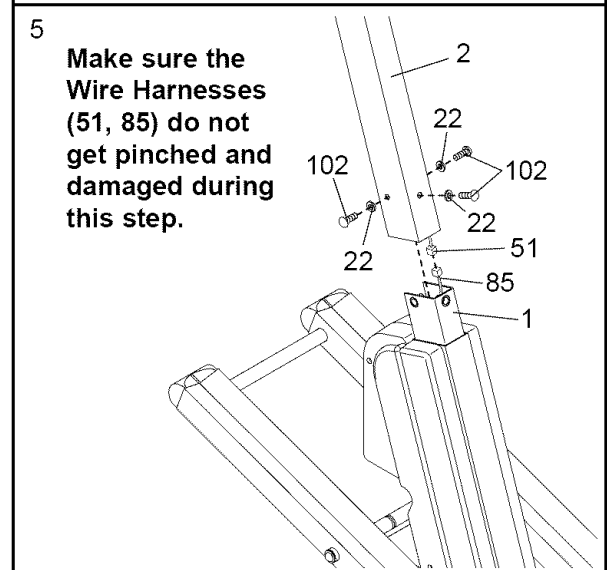

- Connect the wire harness on the Console (87) to the Extension Wire Harness (51).

Attach the Console (87) to the Upright (2) with the four Console Screws (35) and the four Console Washers (93) packaged with the Console. **Be careful to avoid pinching the wire harnesses.**

Snap the bookrack onto the Console (87) in the location shown.

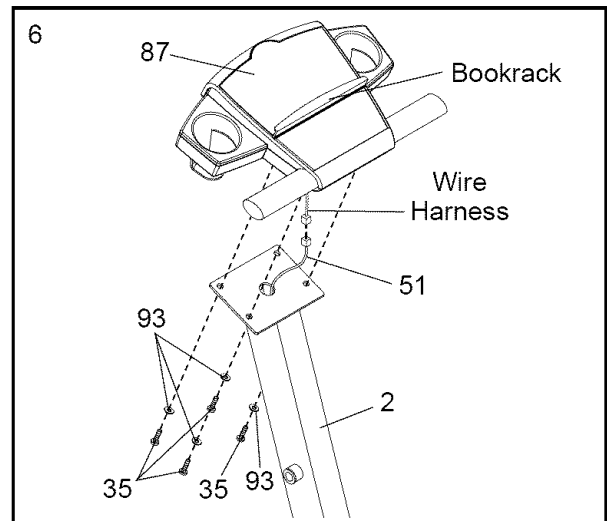

- Identify the Left Pedal (41). Attach the Left Pedal to the Left Spring Arm (3) with an M10 x 33mm Carriage Bolt (61), an M10 Washer (63), and an Adjustment Knob (77) as shown. Note: The Left Pedal can be attached in any of five positions (see HOW TO ADJUST THE PEDALS on page 9).

Attach the Right Pedal (not shown) in the same way. Make sure that both Pedals are in the same position.

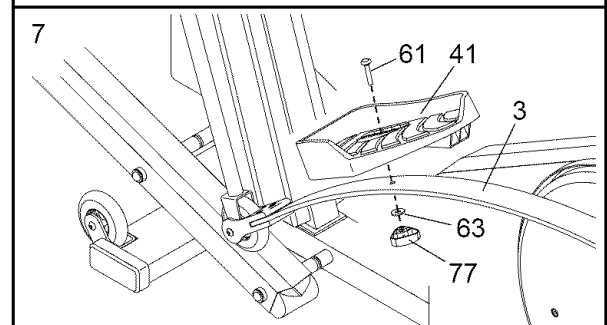

- Apply a small amount of the included Teflon® lubricant to a paper towel. Rub a thin film of the lubricant onto the Chrome Tubes (21). Next, slide the Left Upper Body Arm (7), which is marked with a sticker, onto the left Chrome Tube. Slide the Right Upper Body Arm (75) onto the right Chrome Tube. **Make sure that the Upper Body Arms are on the correct sides—the upper ends should bend in the direction shown by the arrows.** Next, slide an Axle Cover (74) onto the post on each Upper Body Arm.

Apply grease to the Arm Axle (19). Insert the Arm Axle into the right Axle Cover (74) and the Right Upper Body Arm (75). Next, insert the Arm Axle into the Upright (2) until the left end of the Arm Axle is flush with the left side of the Upright. Then, insert the Arm Axle into the left Axle Cover (74) and the Left Upper Body Arm (7).

Center the Arm Axle (19). Using the included pedal tool, tap two Push Nuts (15) **about 1/8"** onto each end of the Arm Axle. Make sure that the Push Nuts are turned as shown in the inset drawing. (Note: It may be helpful if another person holds a block of wood against one end of the Arm Axle while you tap Push Nuts onto the other end.) Then, press an Axle Cap (34) onto each end of the Arm Axle.

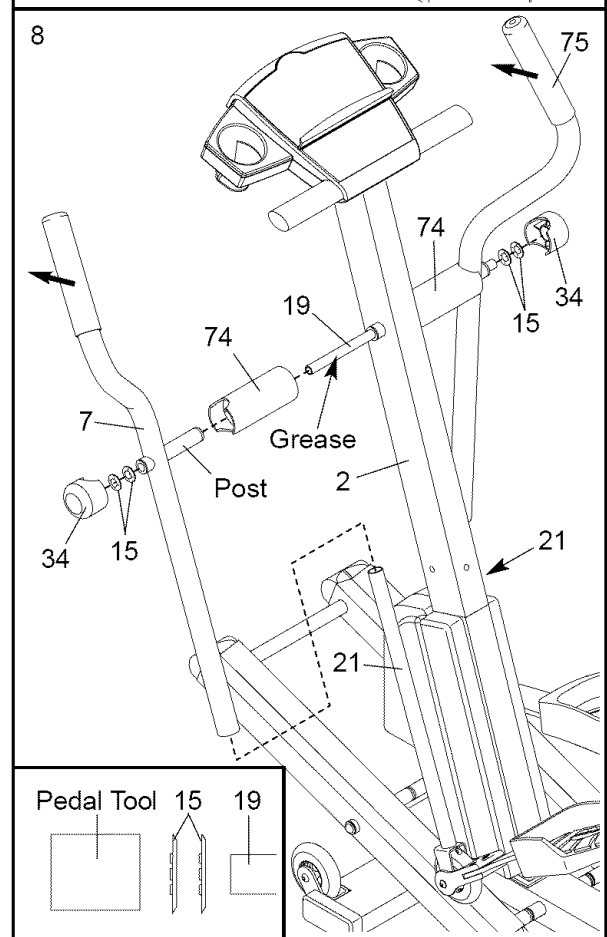

- Make sure that all parts of the elliptical crosstrainer are properly tightened.** Note: Some hardware may be left over after assembly is completed.

## INSTALLING THE RECEIVER FOR THE OPTIONAL CHEST PULSE SENSOR

If you purchase the optional chest pulse sensor (refer to page 19), follow the steps below to install the receiver and the Y-connector included with the chest pulse sensor.

1. Remove the four indicated screws from the back of the Console (87). Lift the top of the Console. **Be careful not to disconnect any wires.**

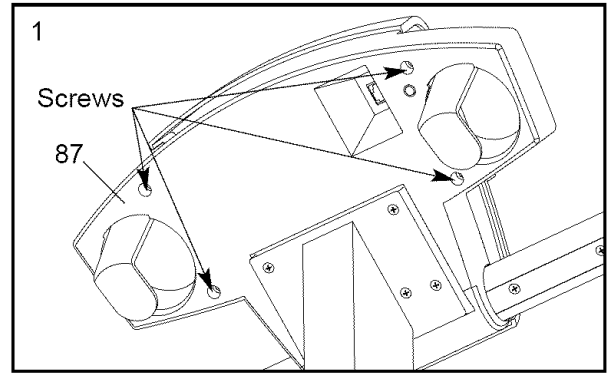

2. Peel the paper off the adhesive pad on the back of the receiver (A). Orient the receiver exactly as shown, and press it onto the Console (87) in the indicated location.

Connect the wire on the receiver (A) to the Y-connector (B) as shown. Unplug the indicated console wire (C) from the indicated jack (D), and plug the console wire into the Y-connector. Then, plug the Y-connector into the jack (D).

Refer to step 1 above. Reattach the top of the Console (87) with the four screws. **Make sure that no wires are pinched.**

Note: Any other wires that are included with the chest pulse sensor may be discarded.

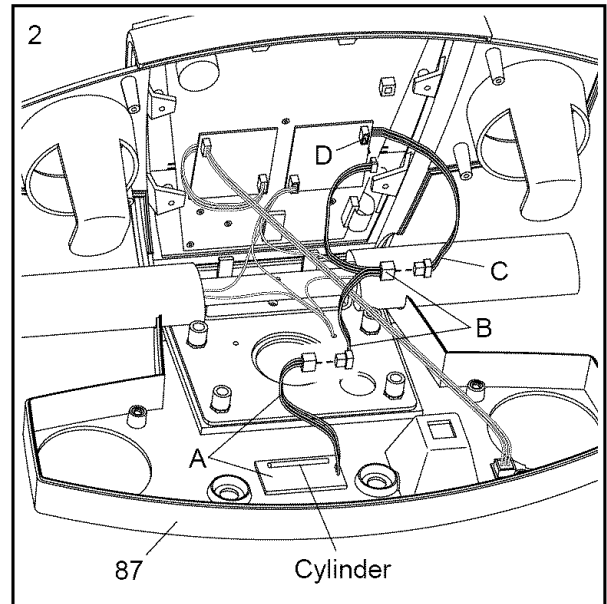

## HOW TO USE THE ELLIPTICAL CROSSTRAINER

### HOW TO PLUG IN THE POWER CORD

**This product must be grounded.** If it should malfunction or break down, grounding provides a path of least resistance for electric

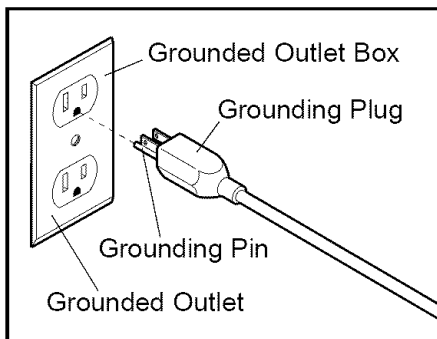

current to reduce the risk of electric shock. This product is equipped with a cord having an equipment-grounding conductor and a grounding plug. **Plug the power cord into an appropriate outlet that is prop-**

erly installed and grounded in accordance with all local codes and ordinances. This product is for use on a nominal 120-volt circuit. **Important:** The elliptical crosstrainer is not compatible with GFCI-equipped outlets.

**⚠ DANGER:** Improper connection of the equipment-grounding conductor can result in an increased risk of electric shock. Check with a qualified electrician or serviceman if you are in doubt as to whether the product is properly grounded. Do not modify the plug provided with the product—if it will not fit the outlet, have a proper outlet installed by a qualified electrician.



A temporary adapter may be used to connect the power cord to a 2-pole receptacle as shown at the right if a properly grounded outlet is not available. The temporary adapter should be used only until a properly grounded outlet can be installed by a qualified electrician.

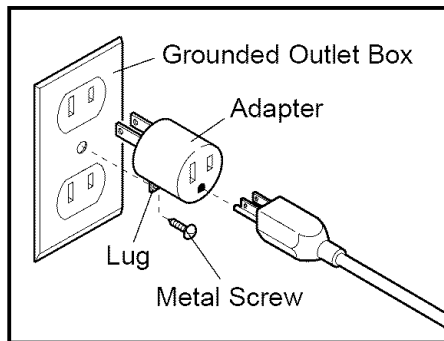

The green-colored rigid ear, lug, or the like extending from the adapter must be connected to a permanent ground such as a properly grounded outlet box cover. Whenever the adapter is used, it must be held in place by a metal screw. **Some 2-pole receptacle outlet box covers are not grounded. Contact a qualified electrician to determine if the outlet box cover is grounded before using an adapter.**

#### HOW TO ADJUST THE PEDALS

The motion of the pedals is determined by their positions on the spring arms. There are five different pedal positions. To adjust the pedals, first loosen the knob beneath each pedal. Slide the pedals forward or backward to the desired position, and then retighten the knobs. Make sure that both pedals are in the same position.

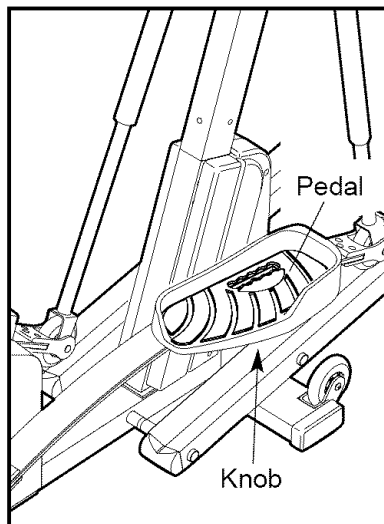

#### EXERCISING ON THE ELLIPTICAL CROSSTRAINER

To mount the elliptical crosstrainer, hold the handgrip pulse sensor and step onto the pedal that is in the lowest position. Next, step onto the other pedal. Push the pedals until they begin to move with a continuous motion. **Note: The pedal disks can turn in either direction. It is recommended that you turn the pedal disks in the direction shown by the arrow below. To give variety to your exercise, turn the pedal disks in the opposite direction.**

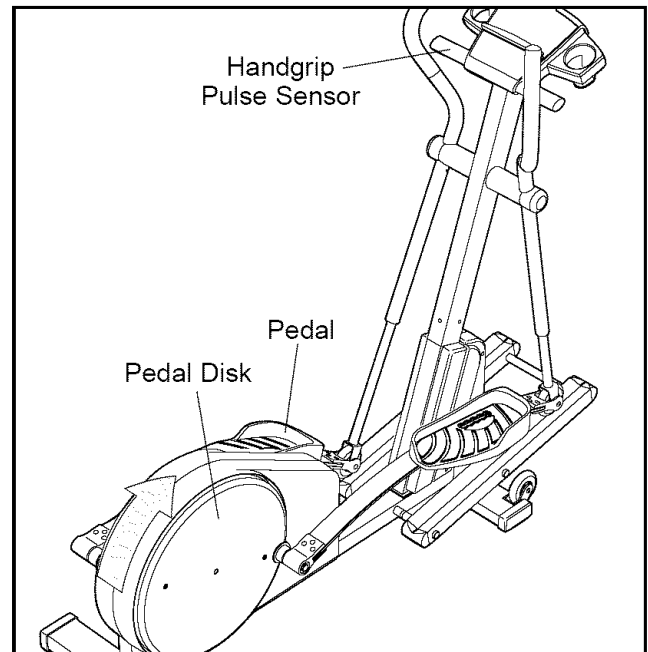

To dismount the elliptical crosstrainer, wait until the pedals come to a complete stop. **The elliptical crosstrainer does not have a free wheel; the pedals will continue to move until the flywheel stops.** When the pedals are stationary, step off the highest pedal first. Then, step off the lowest pedal.

#### HOW TO USE THE UPPER BODY ARMS

As you exercise, push and pull the upper body arms in order to work your arms, back, and shoulders. To exercise only your lower body, hold the handgrip pulse sensor as you exercise.

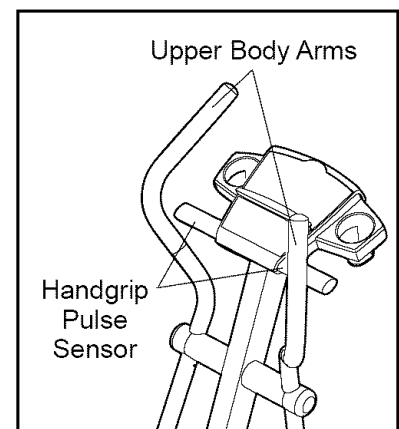

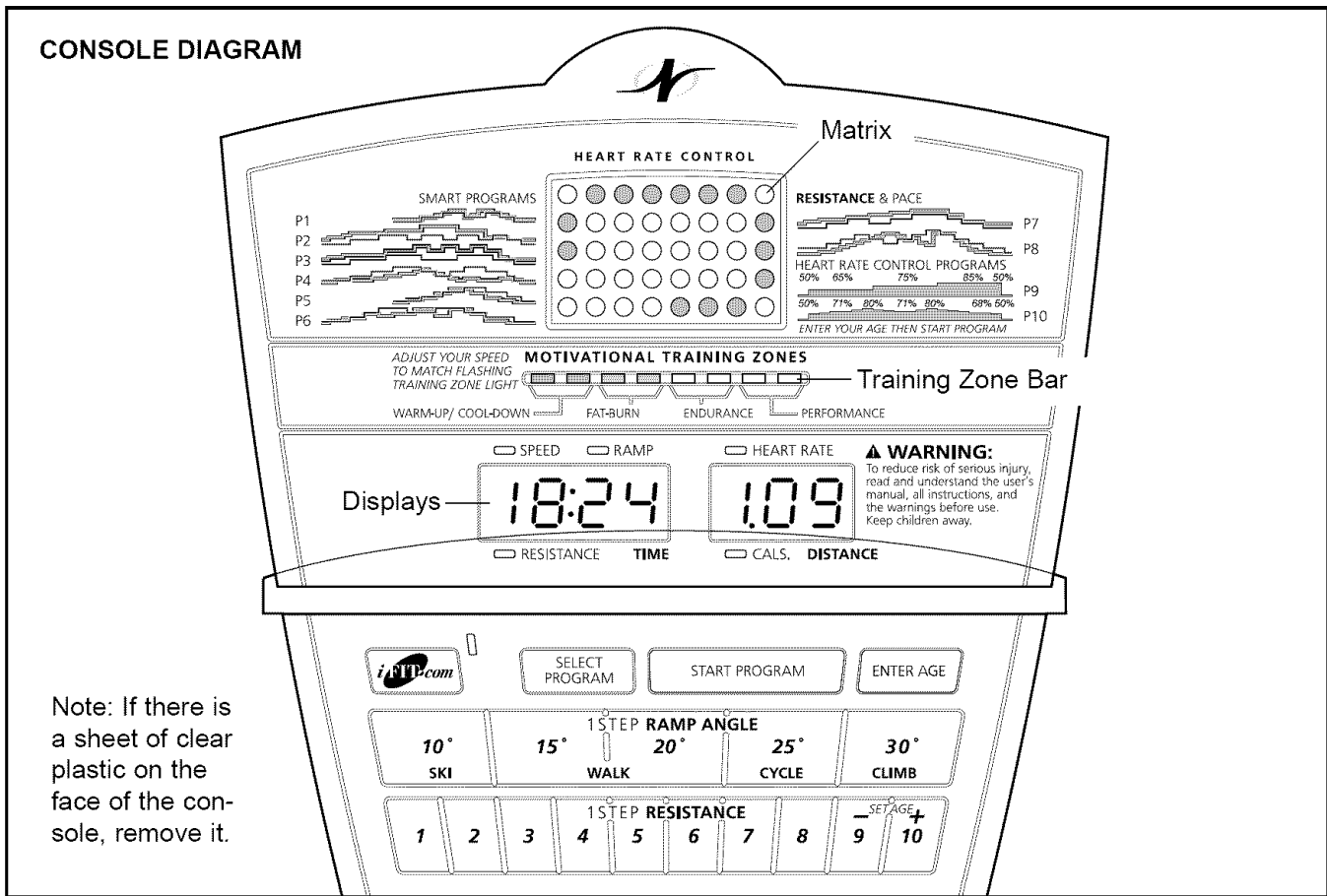

## FEATURES OF THE CONSOLE

The advanced console offers a selection of features designed to make your workouts more enjoyable and effective. When the manual mode of the console is selected, the resistance of the elliptical crosstrainer and the angle of the incline ramp can be changed with a touch of a button. As you exercise, the console will provide continuous exercise feedback. You can even measure your heart rate using the handgrip pulse sensor. (For information about an optional chest pulse sensor, refer to page 19.)

The console also offers eight smart workout programs. Each program automatically changes the resistance of the elliptical crosstrainer and prompts you to increase or decrease your pace as it guides you through an effective workout.

In addition, the console features two heart rate workout programs that automatically change the resistance of the elliptical crosstrainer and prompt you to vary your pace to keep your heart rate near a target heart rate as you exercise.

The console also features new iFIT.com interactive technology. iFIT.com technology is like having a per-

sonal trainer right in your home. Using the included audio cable, you can connect the elliptical crosstrainer to your home stereo, portable stereo, or computer and play special iFIT.com CD programs (CDs are available separately). iFIT.com CD programs automatically control the resistance of the elliptical crosstrainer and prompt you to vary your pace as a personal trainer coaches you through every step of your workout. High-energy music provides added motivation. Each CD features two programs designed by certified personal trainers.

In addition, you can connect the elliptical crosstrainer to your VCR and TV and play iFIT.com video programs (videocassettes are available separately). Video programs offer the same benefits as iFIT.com CD programs, but add the excitement of working out with a class and an instructor.

With the elliptical crosstrainer connected to your computer, you can also go to our new Web site at [www.iFIT.com](http://www.iFIT.com) and access audio programs and video programs directly from the internet.

**To purchase iFIT.com CDs and videocassettes, call toll-free 1-800-735-0768.**

## HOW TO USE THE MANUAL MODE

### 1 Make sure that the power cord is plugged in.

Make sure that the power cord is properly plugged in (see HOW TO PLUG IN THE POWER CORD on page 8).

Note: When the power cord is plugged in, the elliptical cross-trainer may automatically calibrate itself. During calibration, the letters CAL will appear in the left display and the indicators in the Training Zone bar will flash in sequence. Calibration will last one to two minutes.

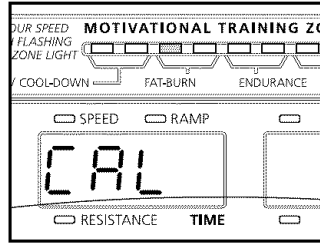

### 2 Press any button on the console or move the pedals to turn on the power.

When any button on the console is pressed or the pedals are moved, the displays and various indicators will light. Note: If the power cord was just plugged in, the power will already be on.

### 3 Select the manual mode.

When the power is turned on, the manual mode will be selected. If you have selected a smart program, a heart rate program, or the iFIT.com mode, select the manual mode by pressing the Select Program button repeatedly until a track appears in the matrix.

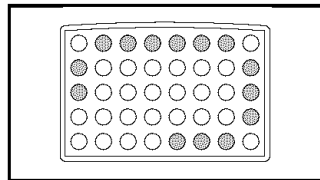

### 4 Begin exercising and adjust the resistance of the elliptical cross-trainer and the angle of the incline ramp as desired.

As you exercise, change the resistance of the elliptical cross-trainer by pressing the Resistance buttons. There are ten resistance levels; level 10 is the most challenging. Note: After the Resistance buttons are pressed, it will take a moment for the pedals to reach the selected resistance level.

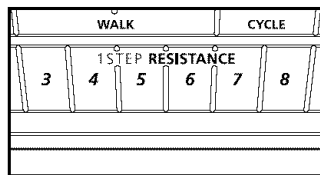

To vary the affect of your exercise on the elliptical cross-trainer, increase or decrease the angle of the incline ramp by pressing the Ramp Angle buttons. There are five ramp angles. Note: After the Ramp Angle buttons are pressed, it will take a moment for the ramp to reach the selected angle.

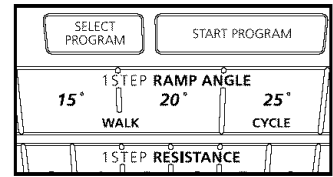

### 5 Watch your progress with the matrix, the Training Zone bar, and the two displays.

**The matrix—** When the manual mode or the iFIT.com mode is selected, the matrix will show a track representing 1/4 mile. As you exercise, the indicators around the track will flash to indicate your position on the track. When you have completed a lap, a new lap will begin.

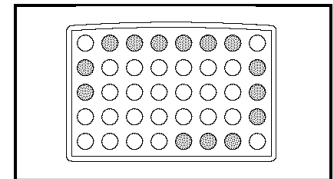

**The Training Zone bar—** The Training Zone bar will show your pace and the approximate intensity level of your exercise. For example, if three or four indicators in the bar are lit, the bar shows that your pace is ideal for fat burning. During smart programs and heart rate programs, the Training Zone bar will also prompt you to increase or decrease your pace.

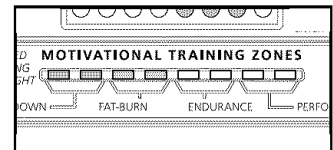

**The left display—** The left display will show the elapsed time, the resistance level, your speed, and the angle of the incline ramp. The display will change from one number to the next every few seconds, as shown by the indicators around the display. When a smart program or a heart rate program is selected, the display will show the time remaining in the program rather than the elapsed time.

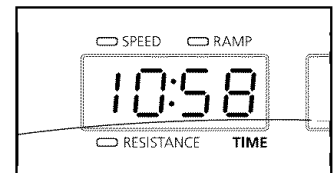

**The right display**—The right display will show the distance you have pedaled and the approximate number of calories you have burned. The display will change from one number to the other every few seconds, as shown by the indicators. The display will also show your heart rate when the pulse sensor is used.

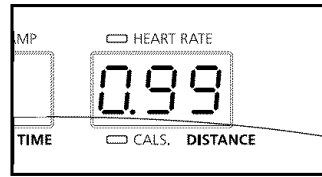

If you stop exercising for several seconds, a tone will sound and the console will pause.

Note: The console can display speed and distance in either miles or kilometers. To determine which unit of measurement is selected,

hold down the Start Program button for three seconds. An E for English miles or an M for metric kilometers will appear in the matrix. To change the unit of measurement, press the + button (this is the button that also selects resistance level 10). While an E or an M appears in the matrix, the left display will show the total numbers of hours that the elliptical crosstrainer has been used, and the right display will show the total number of miles pedaled. When you are finished viewing this information, press the Start Program button again.

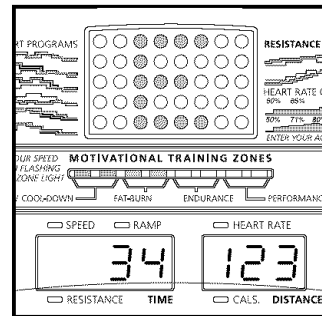

**6 Measure your heart rate if desired.**

**Note: If you wear the optional chest pulse sensor (see page 19) and hold the handgrip pulse sensor at the same time, the console may not display your heart rate accurately.**

If there are thin sheets of plastic on the metal contacts on the handgrip pulse sensor, peel off the plastic. To measure your heart rate, place your hands on the contacts; your palms must be resting on the contacts closest to you, and your fingers must be touching the other contacts. **Avoid moving your hands.**

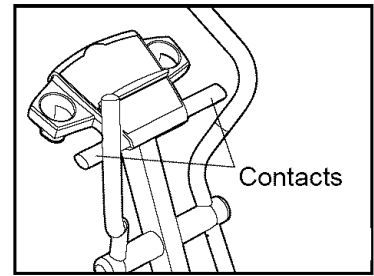

When your pulse is detected, the heart rate indicator above the right display will light, dashes may appear in the display, and then your heart rate will be shown. For the most accurate heart rate reading, continue holding the contacts for about 15 seconds. Note: If your heart rate is not shown, make sure that your hands are positioned as described. Be careful not to move your hands excessively or to squeeze the metal contacts too tightly.

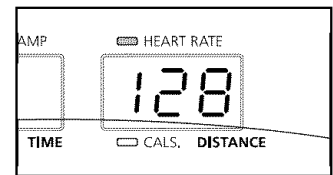

When you hold the pulse sensor, the right display will show your heart rate for about 15 seconds. If you continue to hold the pulse sensor, the display will show your heart rate along with the distance you have pedaled and the number of calories you have burned.

**7 When you are finished exercising, the console will automatically turn off.**

If the console buttons are not pressed and the pedals are not moved for a few minutes, the console will automatically turn off.

## HOW TO USE A SMART PROGRAM

### 1 Make sure that the power cord is plugged in.

Refer to step 1 on page 11.

### 2 Press any button on the console or move the pedals to turn on the power.

Refer to step 2 on page 11.

### 3 Select one of the eight smart programs.

When the power is turned on, the manual mode will be selected. To select a smart program, press the Select Program

button repeatedly until a P-1, P-2, P-3, P-4, P-5, P-6, P-7, or P-8 appears in the left display.

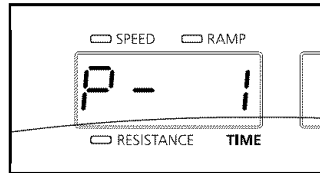

The profiles labeled P1 to P8 on the console show the resistance and pace settings for the smart programs. For example, profile P5 shows that during program 5 both the resistance and the pace will gradually increase during the first half of the program, and then decrease during the last half. Note: When you select a smart program, the matrix will show a simplified profile of the program.

### 4 Start the program.

To start the program, press the Start Program button or simply begin exercising. Each program is divided into several one-, two-, three-, and four-minute segments. One resistance setting and one pace setting are programmed for each segment. (The same resistance setting and/or pace setting may be programmed for two or more consecutive segments.)

The resistance setting for the first segment will be shown in the flashing Current Segment column of the matrix. The resistance settings for the next five segments will be shown in the columns to the right. When only three seconds remain in the first segment, both the Current Segment column and the column to the right will flash, a series of tones will sound, and *all resistance settings will move one column to the left.*

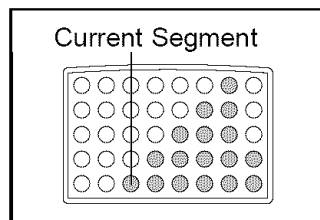

The resistance setting for the second segment will then be shown in the flashing Current Segment column and the resistance of the elliptical crosstrainer will automatically adjust to the second setting.

The pace settings for the program will be shown by the Training Zone bar. The lit indicators in the bar will show your actual pace. If an indicator to the right of the lit indicators flashes (see drawing a), increase your pace. If an indicator to the left of any lit indicator flashes (see drawing b), decrease your pace. When no indicator is flashing, your pace matches the current pace setting. **Important: The pace settings are intended only to provide motivation. Your actual pace may be slower than the current pace setting. Make sure to exercise at a pace that is comfortable for you.**

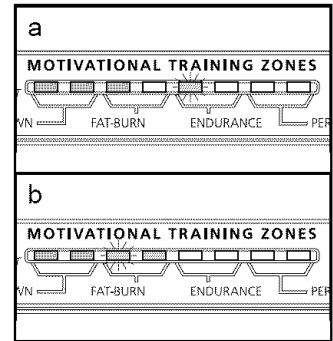

If an indicator to the left of any lit indicator flashes (see drawing b), decrease your pace. When no indicator is flashing, your pace matches the current pace setting. **Important: The pace settings are intended only to provide motivation. Your actual pace may be slower than the current pace setting. Make sure to exercise at a pace that is comfortable for you.**

The program will continue until the resistance setting for the last segment is shown in the Current Segment column of the matrix and the left display shows that no time remains in the program.

Note: During the program, you can adjust the angle of the incline ramp with the Ramp Angle buttons. In addition, you can override the resistance setting for the current segment, if desired, with the Resistance buttons. However, when the next segment begins, the resistance will automatically adjust to the setting for the next segment. If you stop exercising for several seconds, a tone will sound and the program will pause. To restart the program, simply resume exercising.

### 5 Watch your progress with the two displays.

Refer to step 5 on page 11.

### 6 Measure your heart rate, if desired.

Refer to step 6 on page 12.

### 7 When the program is finished, the console will automatically turn off.

See step 7 on page 12.

## HOW TO USE A HEART RATE PROGRAM

Each heart rate program helps you to keep your heart rate near a certain *percentage* of your *maximum heart rate* during your workout. (Your maximum heart rate is estimated by subtracting your age from 220. For example, if you are 30 years old, your maximum heart rate is 190.) Heart rate program 9 is designed to keep your heart rate between 50% and 85% of your maximum heart rate while you exercise; heart rate program 10 is designed to keep your heart rate between 50% and 80% of your maximum heart rate.

Follow the steps below to use a heart rate program.

### 1 Make sure that the power cord is plugged in.

Refer to step 1 on page 11.

### 2 Press any button on the console or move the pedals to turn on the power.

Refer to step 2 on page 11.

### 3 Select one of the heart rate programs.

When the power is turned on, the manual mode will be selected. To select a heart rate program, press the Select Program button repeatedly until a P-9 or P-10 appears in the left display.

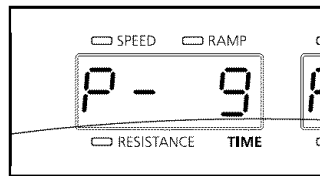

The profiles labeled P9 and P10 on the console show the resistance settings for the heart rate programs. For example, profile P9 shows that during program 9 the resistance will gradually increase during the program and then decrease near the end. Note: When you select a heart rate program, the matrix will show a simplified profile of the program.

### 4 Enter your age.

When a heart rate program is selected, the word AGE and the current age setting will flash in the right display. You must enter your age to use a heart rate program. If you have already entered your age, press the

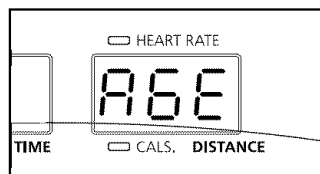

Enter Age button and go to step 5. If you have not entered your age, press the + or – button repeatedly (these are the buttons that select resistance levels 9 and 10) to enter your age, and then press the Enter Age button. Once you have entered your age, your age will be saved in memory.

### 5 Hold the handgrip pulse sensor.

To use a heart rate program, you must use the handgrip pulse sensor (refer to step 6 on page 12) or the optional chest pulse sensor (refer to page 19). If you use the handgrip pulse sensor, it is not necessary to hold the handgrips continuously during the program. However, you should hold the handgrips frequently for the program to operate properly. **Each time you hold the handgrips, keep your hands on the metal contacts for at least 30 seconds.**

### 6 Start the program.

To start the program, press the Start Program button or simply begin exercising. Each heart rate program consists of twenty, one-minute segments. One resistance setting and one heart rate setting are programmed for each segment. (The same resistance setting and/or heart rate setting may be programmed for two or more consecutive segments.)

The resistance setting for the first segment will be shown in the flashing Current Segment column of the matrix. The resistance settings for the next five segments will be shown in the columns to the right. When only three seconds remain in the first segment, both the Current Segment column and the column to the right will flash, a series of tones will sound, and *all resistance settings will move one column to the left.*

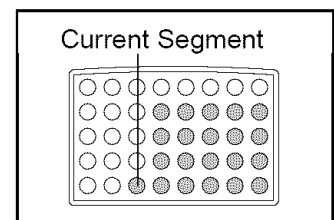

The resistance setting for the second segment will then be shown in the flashing Current Segment column and the resistance of the elliptical crosstrainer will automatically adjust to the second setting.

As you exercise, the Training Zone bar will help you to keep your heart rate near the heart rate setting for the current segment. The lit indicators in the bar will show your actual pace. When you hold the handgrip pulse sensor (or wear the optional chest pulse sensor), the console will periodically compare your heart rate to the heart rate setting for the current segment; if necessary, an indicator in the bar will then flash to prompt you to increase or decrease your pace to bring your heart rate closer to the current heart rate setting. If an indicator to the right of the lit indicators flashes (see drawing a above), increase your pace. If an indicator to the left of any lit indicator flashes (see drawing b), decrease your pace. When no indicator is flashing, your heart rate is near the current heart rate setting.

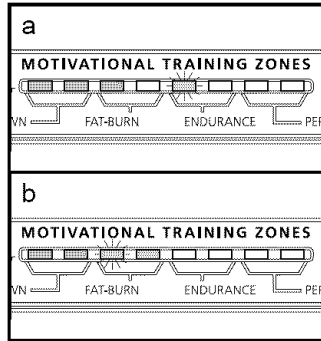

Important: The heart rate settings are intended only to provide motivation. Your actual heart rate may be slower than the current heart rate setting. Make sure to exercise at a pace that is comfortable for you.

The program will continue until the resistance setting for the last segment is shown in the Current Segment column of the matrix and the left display shows that no time remains in the program.

Note: During the program, you can adjust the angle of the incline ramp with the Ramp Angle buttons. In addition, you can manually override the resistance setting for the current segment, if desired, with the Resistance buttons. However, when the next segment begins, the resistance will automatically adjust to the setting for the next segment. If you stop exercising for six seconds or longer, a tone will sound and the program will pause.

## 7 Watch your progress with the two displays.

Refer to step 5 on page 11.

## 8 When the program is finished, the console will automatically turn off.

See step 7 on page 12.

## HOW TO CONNECT YOUR CD PLAYER, VCR, OR COMPUTER

To use iFIT.com CDs, the elliptical crosstrainer must be connected to your portable CD player, portable stereo, home stereo, or computer with CD player. See pages 15 to 17 for connecting instructions. To use iFIT.com videocassettes, the elliptical crosstrainer must be connected to your VCR. See page 17 for connecting instructions. To use iFIT.com programs directly from our Web site, the elliptical crosstrainer must be connected to your home computer. See page 17 for connecting instructions.

### HOW TO CONNECT YOUR PORTABLE CD PLAYER

Note: If your CD player has separate LINE OUT and PHONES jacks, see instruction A below. If your CD player has only one jack, see instruction B.

- A. Plug one end of the audio cable into the jack beneath the console. Plug the other end of the cable into the LINE OUT jack on your CD player. Plug your headphones into the PHONES jack.

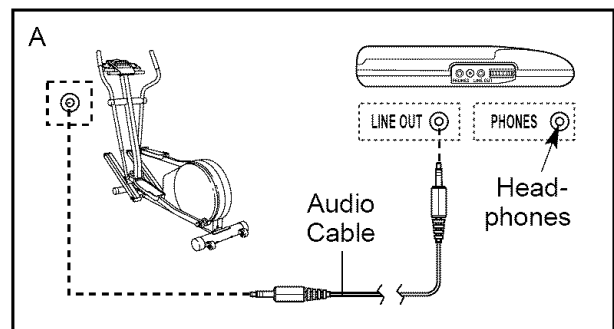

- B. Plug one end of the audio cable into the jack beneath the console. Plug the other end of the cable into a 1/8" Y-adapter (available at electronics stores). Plug the Y-adapter into the PHONES jack on your CD player. Plug your headphones into the other side of the Y-adapter.

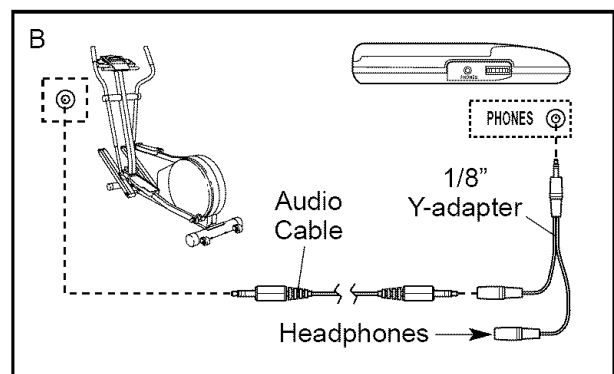

## HOW TO CONNECT YOUR PORTABLE STEREO

**Note:** If your stereo has an RCA-type AUDIO OUT jack, see instruction A below. If your stereo has a 1/8" LINE OUT jack, see instruction B. If your stereo has only a PHONES jack, see instruction C.

- A. Plug one end of the audio cable into the jack beneath the console. Plug the other end of the cable into the adapter. Plug the adapter into an AUDIO OUT jack on your stereo.

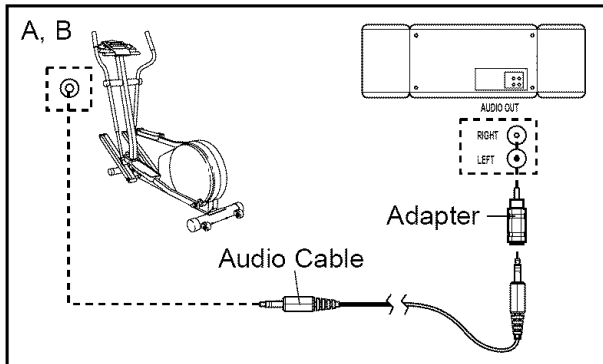

- B. Plug one end of the audio cable into the jack beneath the console. Plug the other end of the cable into the LINE OUT jack on your stereo. Do not use the adapter.
- C. Plug one end of the audio cable into the jack beneath the console. Plug the other end of the cable into a 1/8" Y-adapter (available at electronics stores). Plug the Y-adapter into the PHONES jack on your stereo. Plug your headphones into the other side of the Y-adapter.

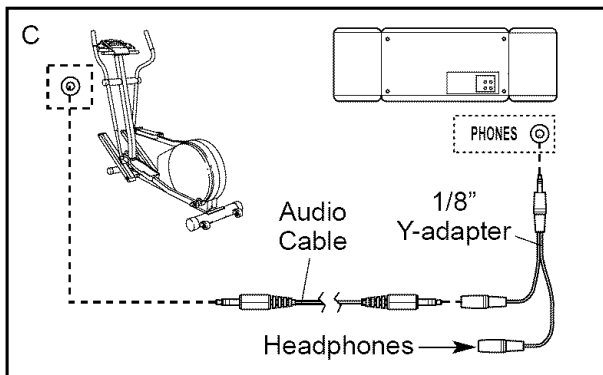

## HOW TO CONNECT YOUR HOME STEREO

**Note:** If your stereo has an unused LINE OUT jack, see instruction A below. If the LINE OUT jack is being used, see instruction B.

- A. Plug one end of the audio cable into the jack beneath the console. Plug the other end of the cable into the adapter. Plug the adapter into the LINE OUT jack on your stereo.

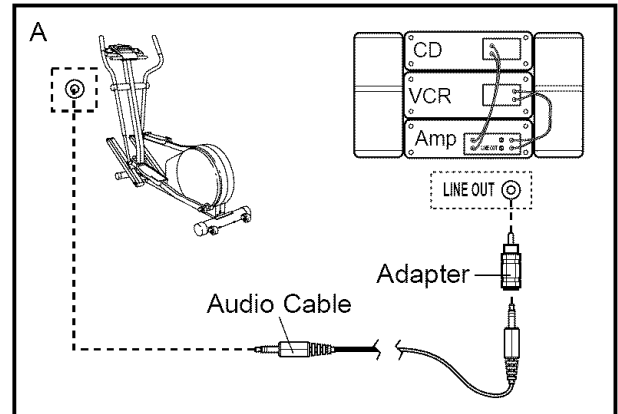

- B. Plug one end of the audio cable into the jack beneath the console. Plug the other end of the cable into the adapter. Plug the adapter into an RCA Y-adapter (available at electronics stores). Next, remove the wire that is currently plugged into the LINE OUT jack on your stereo and plug the wire into the unused side of the Y-adapter. Plug the Y-adapter into the LINE OUT jack on your stereo.

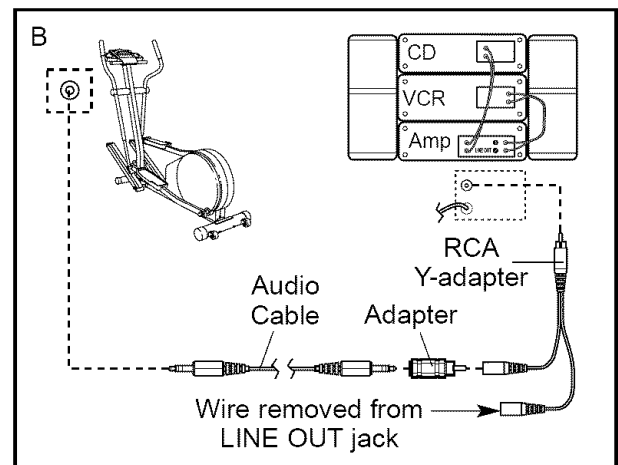



## HOW TO CONNECT YOUR COMPUTER

**Note:** If your computer has a 1/8" LINE OUT jack, see instruction A. If your computer has only a PHONES jack, see instruction B.

- A. Plug one end of the audio cable into the jack beneath the console. Plug the other end of the cable into the LINE OUT jack on your computer.

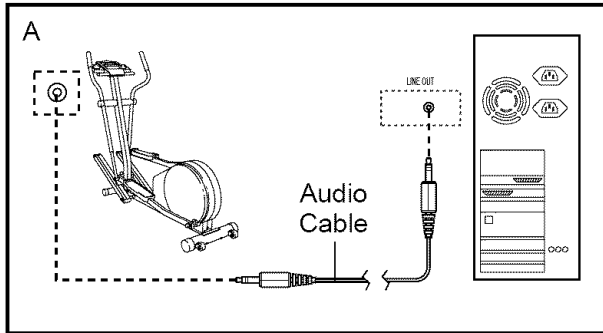

- B. Plug one end of the audio cable into the jack beneath the console. Plug the other end of the cable into a 1/8" Y-adapter (available at electronics stores). Plug the Y-adapter into the PHONES jack on your computer. Plug your headphones or speakers into the other side of the Y-adapter.

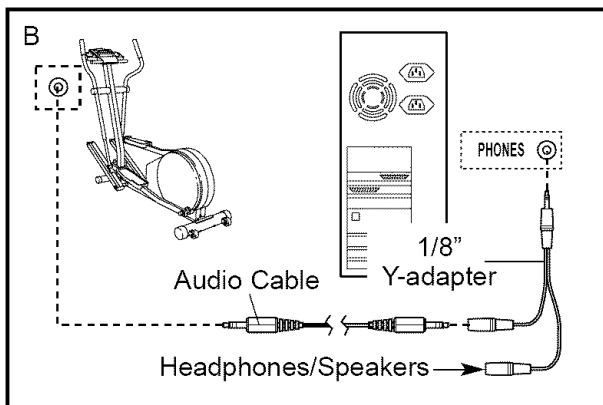

## HOW TO CONNECT YOUR VCR

**Note:** If your VCR has an unused AUDIO OUT jack, see instruction A below. If the AUDIO OUT jack is being used, see instruction B. If you have a TV with a built-in VCR, see instruction B. If your VCR is connected to your home stereo, see HOW TO CONNECT YOUR HOME STEREO on page 16.

- A. Plug one end of the audio cable into the jack beneath the console. Plug the other end of the cable into the adapter. Plug the adapter into the AUDIO OUT jack on your VCR.

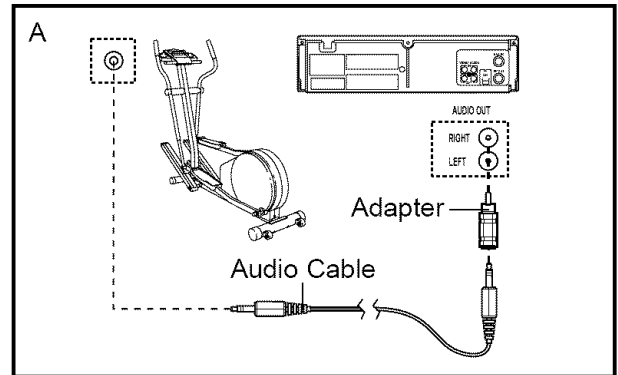

- B. Plug one end of the audio cable into the jack beneath the console. Plug the other end of the cable into an RCA Y-adapter (available at electronics stores). Next, remove the wire that is currently plugged into the AUDIO OUT jack on your VCR and plug the wire into the unused side of the Y-adapter. Plug the Y-adapter into the AUDIO OUT jack on your VCR.

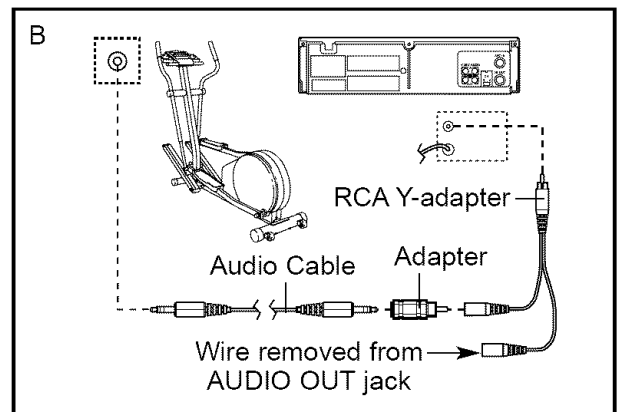

## HOW TO USE iFIT.COM CD AND VIDEO PROGRAMS

To use iFIT.com CDs or videocassettes, the elliptical crosstrainer must be connected to your portable CD player, portable stereo, home stereo, computer with CD player, or VCR. See HOW TO CONNECT YOUR CD PLAYER, VCR, OR COMPUTER on page 15. To purchase iFIT.com CDs and videocassettes, call toll-free 1-800-735-0768.

Follow the steps below to use an iFIT.com CD or video program.

### 1 Make sure that the power cord is plugged in.

Refer to step 1 on page 11.

### 2 Press any button on the console or move the pedals to turn on the power.

Refer to step 2 on page 11.

### 3 Select the iFIT.com mode.

When the console is turned on, the manual mode will be selected. To select the iFIT.com mode, press the iFIT.com button.

The indicator beside the button will light.

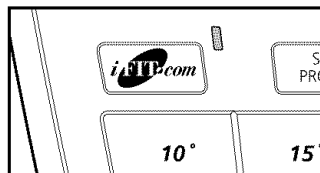

### 4 Insert the iFIT.com CD or videocassette.

If you are using an iFIT.com CD, insert the CD into your CD player. If you are using an iFIT.com videocassette, insert the videocassette into your VCR.

### 5 Press the play button on your CD player or VCR.

A moment after the play button is pressed, your personal trainer will begin guiding you through your workout. Simply follow your personal trainer's instructions.

The program will function in almost the same way as a smart program (refer to step 4 on page 13). However, an electronic "chirping" sound will alert you when the resistance and/or the pace setting is about to change.

**Note: If the resistance of the elliptical cross-trainer and/or the pace setting does not change when a "chirp" is heard:**

- Make sure that the indicator beside the iFIT.com button is lit.
- Adjust the volume of your CD player or VCR. If the volume is too high or too low, the console may not detect the program signals.
- Make sure that the audio cable is properly connected and that it is fully plugged in.

### 6 Watch your progress with the two displays.

Refer to step 5 on page 11.

### 7 Measure your heart rate, if desired.

Refer to step 6 on page 12.

### 8 When the program is finished, the console will automatically turn off.

See step 7 on page 12.

## HOW TO USE PROGRAMS DIRECTLY FROM OUR WEB SITE

Our Web site at [www.iFIT.com](http://www.iFIT.com) allows you to play iFIT.com audio and video programs directly from the internet. To use programs from our Web site, the elliptical crosstrainer must be connected to your home computer. See HOW TO CONNECT YOUR COMPUTER on page 17. In addition, you must have an internet connection and an internet service provider. A list of specific system requirements will be found on our Web site.

Follow the steps below to use a program from our Web site.

### 1 Make sure that the power cord is plugged in.

Refer to step 1 on page 11.

### 2 Press any button on the console or move the pedals to turn on the power.

Refer to step 2 on page 11.

### 3 Select the iFIT.com mode.

When the console is turned on, the manual mode will be selected. To select the iFIT.com mode, press the iFIT.com button.

The indicator beside the button will light.

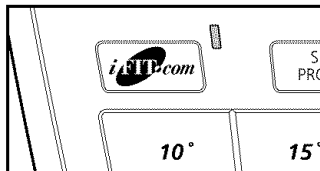

### 4 Go to your computer and start an internet connection.

### 5 Start your Web browser, if necessary, and go to our Web site at [www.iFIT.com](http://www.iFIT.com).

### 6 Follow the desired links on our Web site to select a program.

Read and follow the on-line instructions for using a program.

### 7 Follow the on-line instructions to start the program.

When you start the program, an on-screen countdown will begin.

### 8 Return to the elliptical crosstrainer and begin exercising.

When the on-screen countdown ends, the program will begin. The program will function in almost the same way as a Smart program (refer to step 4 on page 13). However, an electronic “chirping” sound will alert you when the resistance and/or the pace setting is about to change.

### 9 Follow your progress with the two displays.

Refer to step 5 on page 11.

### 10 Measure your heart rate if desired.

Refer to step 6 on page 12.

### 11 When you are finished exercising, the console will automatically turn off.

Refer to step 7 on page 12.

## THE OPTIONAL CHEST PULSE SENSOR

The optional chest pulse sensor provides hands-free operation and continuously monitors your heart rate during your workouts. **To purchase the optional chest pulse sensor, call toll-free 1-800-734-2377.**

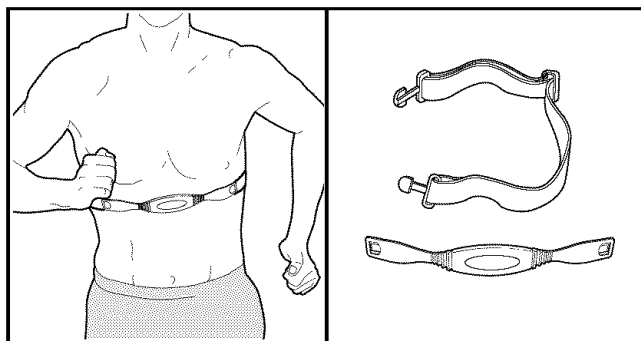

# MAINTENANCE AND TROUBLESHOOTING

Inspect and properly tighten all parts of the elliptical crosstrainer regularly. Replace any worn parts immediately.

For smooth operation of the elliptical crosstrainer, the incline ramp should be kept clean. Using a soft cloth and mild detergent, clean dust and other residue from the incline ramp where the wheels make contact with it. Other parts of the elliptical crosstrainer can also be cleaned in this way. **Keep liquids off the console. Never use abrasives or solvents.**

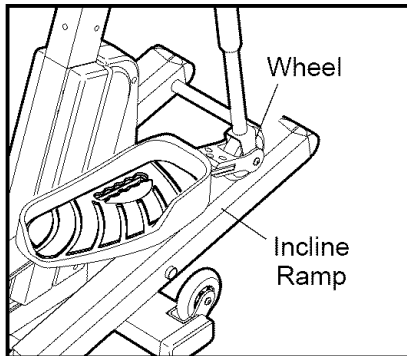

Next, locate the Reed Switch (50). Turn the Flywheel (37) until the Magnet (55) is aligned with the Reed Switch. Loosen, but do not remove, the indicated Screw (72). Slide the Reed Switch slightly closer to or away from the Magnet. Retighten the Screw. Rock the Flywheel forward and back just enough that the Magnet passes the Reed Switch repeatedly. Repeat until the console displays correct feedback. When the Reed Switch is correctly adjusted, reattach the side shields and the pedal disks.

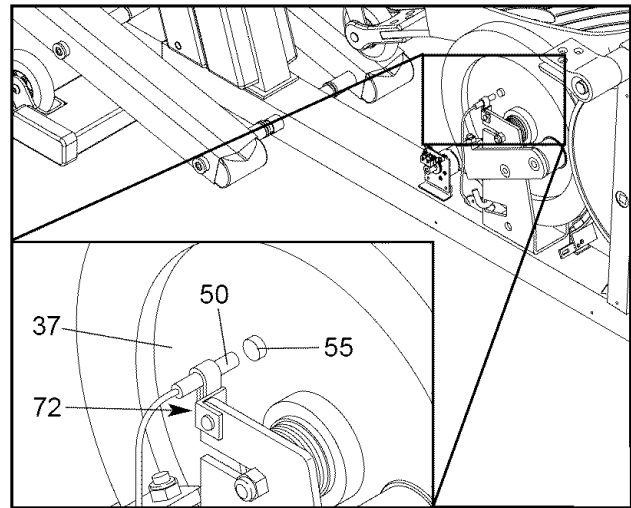

## HOW TO ADJUST THE REED SWITCH

If the console does not display correct feedback, the reed switch should be adjusted. To adjust the reed switch, the Side Shields (47, 48) and the Pedal Disks (40) must be removed. Remove the indicated Screws (72, 88) from both Side Shields and Pedal Disks. Pull the Pedal Disks out of the Side Shields. Lift the Side Shields off the elliptical crosstrainer.

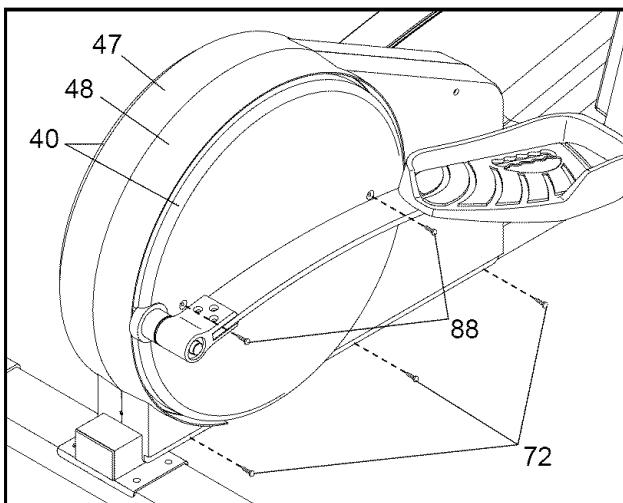

## HOW TO LEVEL THE ELLIPTICAL CROSTRAINER

If the elliptical crosstrainer rocks slightly during use, turn one or both of the leveling feet under the rear stabilizer until the rocking motion is eliminated.

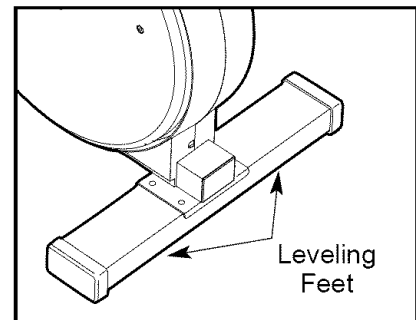

# CONDITIONING GUIDELINES



## WARNING:

1. Before beginning this or any exercise program, consult your physician. This is especially important for persons over the age of 35 or persons with pre-existing health problems.
2. The pulse sensor is not a medical device. Various factors may affect the accuracy of heart rate readings. The pulse sensor is intended only as an exercise aid in determining heart rate trends in general.

The following guidelines will help you to plan your exercise program. Remember that proper nutrition and adequate rest are essential for successful results.

### EXERCISE INTENSITY

Whether your goal is to burn fat or to strengthen your cardiovascular system, the key to achieving the desired results is to exercise with the proper intensity. The proper intensity level can be found by using your heart rate as a guide. The chart below shows recommended heart rates for fat burning, maximum fat burning, and cardiovascular (aerobic) exercise.

165	155	145	140	130	125	115	
145	138	130	125	118	110	103	
125	120	115	110	105	95	90	
<hr/>							
20	30	40	50	60	70	80	

To find the proper heart rate for you, first find your age on the bottom line of the chart (ages are rounded off to the nearest ten years). Next, find the three numbers above your age. The three numbers are your “training zone.” The lower two numbers are recommended heart rates for fat burning; the highest number is the recommended heart rate for aerobic exercise.

### Fat Burning

To burn fat effectively, you must exercise at a relatively low intensity level for a sustained period of time.

During the first few minutes of exercise, your body uses easily accessible *carbohydrate* calories for energy. Only after the first few minutes of exercise does your body begin to use stored *fat* calories for energy. If your goal is to burn fat, adjust the intensity of your exercise until your heart rate is near the lowest number in your training zone as you exercise.

For maximum fat burning, adjust the intensity of your exercise until your heart rate is near the middle number in your training zone as you exercise.

### Aerobic Exercise

If your goal is to strengthen your cardiovascular system, your exercise must be “aerobic.” Aerobic exercise is activity that requires large amounts of oxygen for prolonged periods of time. This increases the demand on the heart to pump blood to the muscles, and on the lungs to oxygenate the blood. For aerobic exercise, adjust the intensity of your exercise until your heart rate is near the highest number in your training zone as you exercise.

### WORKOUT GUIDELINES

Each workout should include the following three parts:

**A warm-up**, consisting of 5 to 10 minutes of stretching and light exercise. A proper warm-up increases your body temperature, heart rate, and circulation in preparation for exercise.

**Training zone exercise**, consisting of 20 to 30 minutes of exercising with your heart rate in your training zone. (During the first few weeks of your exercise program, do not keep your heart rate in your training zone for longer than 20 minutes.)

**A cool-down**, with 5 to 10 minutes of stretching. This will increase the flexibility of your muscles and will help to prevent post-exercise problems.

### EXERCISE FREQUENCY

To maintain or improve your condition, complete three workouts each week, with at least one day of rest between workouts. After a few months of regular exercise, you may complete up to five workouts each week if desired. The key to success is to make exercise a regular and enjoyable part of your everyday life.

# PART LIST—Model No. 831.298651

R0902A

Key No.	Qty.	Description	Key No.	Qty.	Description
1	1	Frame	57	1	Right Rear Spring Bracket
2	1	Upright	58	4	M8 Split Washer
3	1	Left Spring Arm	59	1	Rear Stabilizer
4	1	Right Spring Arm	60	4	M10 x 56mm Screw
5	1	Incline Ramp	61	2	M10 x 33mm Carriage Bolt
6	2	Crank Arm	62	2	Front Stabilizer Endcap
7	1	Left Upper Body Arm	63	2	M10 Washer
8	1	Large Pulley	64	2	Rear Stabilizer Endcap
9	2	Frame Bearing	65	4	M10 x 43mm Screw
10	1	Plastic Crank Spacer	66	1	“J” Bolt
11	1	Flat Delrin Washer	67	4	Spring Bracket Bushing
12	1	Idler Bracket	68	1	Eyebolt
13	1	Power Cord	69	1	“C” Magnet
14	2	Leveling Foot	70	1	Adjustment Bracket
15	4	Push Nut	71	3	M4 x 63.5mm Screw
16	1	M10 x 25mm Flat Head Bolt	72	8	M4 x 16mm Screw
17	2	M8.5 Flat Washer	73	11	M5 x 16mm Screw
18	2	Foam Grip	74	2	Axle Cover
19	1	Arm Axle	75	1	Right Upper Body Arm
20	2	Plastic Arm Sleeve	76	4	Pedal Bushing
21	2	Chrome Tube	77	2	Adjustment Knob
22	11	M10 Split Washer	78	2	Snap Ring
23	6	Arm Bushing	79	2	Spring Spacer
24	2	56mm Spacer	80	4	M8 Nylon Locknut
25	2	Frame Endcap	81	1	Adjustment Cable Assembly
26	2	M10 Nylon Locknut	82	1	Resistance Motor
27	2	M10 Union Bolt Set	83	2	Flange Screw
28	1	Belt	84	1	M6 x 38mm Bolt
29	2	Incline Axle	85	1	Wire Harness
30	4	M8 x 19mm Screw	86	12	M6 Nylon Locknut
31	10	Incline Bushing	87	1	Console
32	4	Incline Ramp Cap	88	4	M5 x 25mm Screw
33	4	M8 Washer	89	3	Stop Nut
34	2	Pivot Axle Cap	90	1	Front Stabilizer
35	4	Console Screw	91	1	Side Shield Support
36	1	Spring	92	12	M6 Washer
37	1	Flywheel	93	4	Console Washer
38	2	Flywheel Bearing	94	1	Incline Motor
39	1	Flywheel Axle	95	1	Reed Switch Lock
40	2	Pedal Disk	96	1	Incline Reed Switch
41	1	Left Pedal	97	4	Tree Fastener
42	1	Right Pedal	98	1	Left Incline Shield
43	12	M6 x 33mm Flat Head Screw	99	1	Right Incline Shield
44	2	Incline Wheel	100	1	Incline Bolt
45	2	Stabilizer Wheel	101	2	Incline Spacer
46	2	M8 Union Bolt Set	102	3	M10 x 25mm Screw
47	1	Left Side Shield	103	1	Zip Tie
48	1	Right Side Shield	104	3	#8 x 3/8” Screw
49	2	M5 x 6mm Screw	105	1	Wiring Board
50	1	Reed Switch/Wire	106	1	Junction Box/Cover
51	1	Extension Wire Harness	107	1	Grommet
52	1	Reed Switch Bracket	#	1	Grease
53	2	Spring Bracket	#	1	Teflon® Lubricant
54	1	Reed Switch Clamp	#	1	Push Nut Tool
55	1	Magnet	#	2	Allen Wrench
56	1	Left Rear Spring Bracket	#	1	User’s Manual

Note: # indicates a non-illustrated part. Specifications are subject to change without notice. See the back cover of this manual for information about ordering replacement parts.

# EXPLODED DRAWING—Model No. 831.298651

R0902A

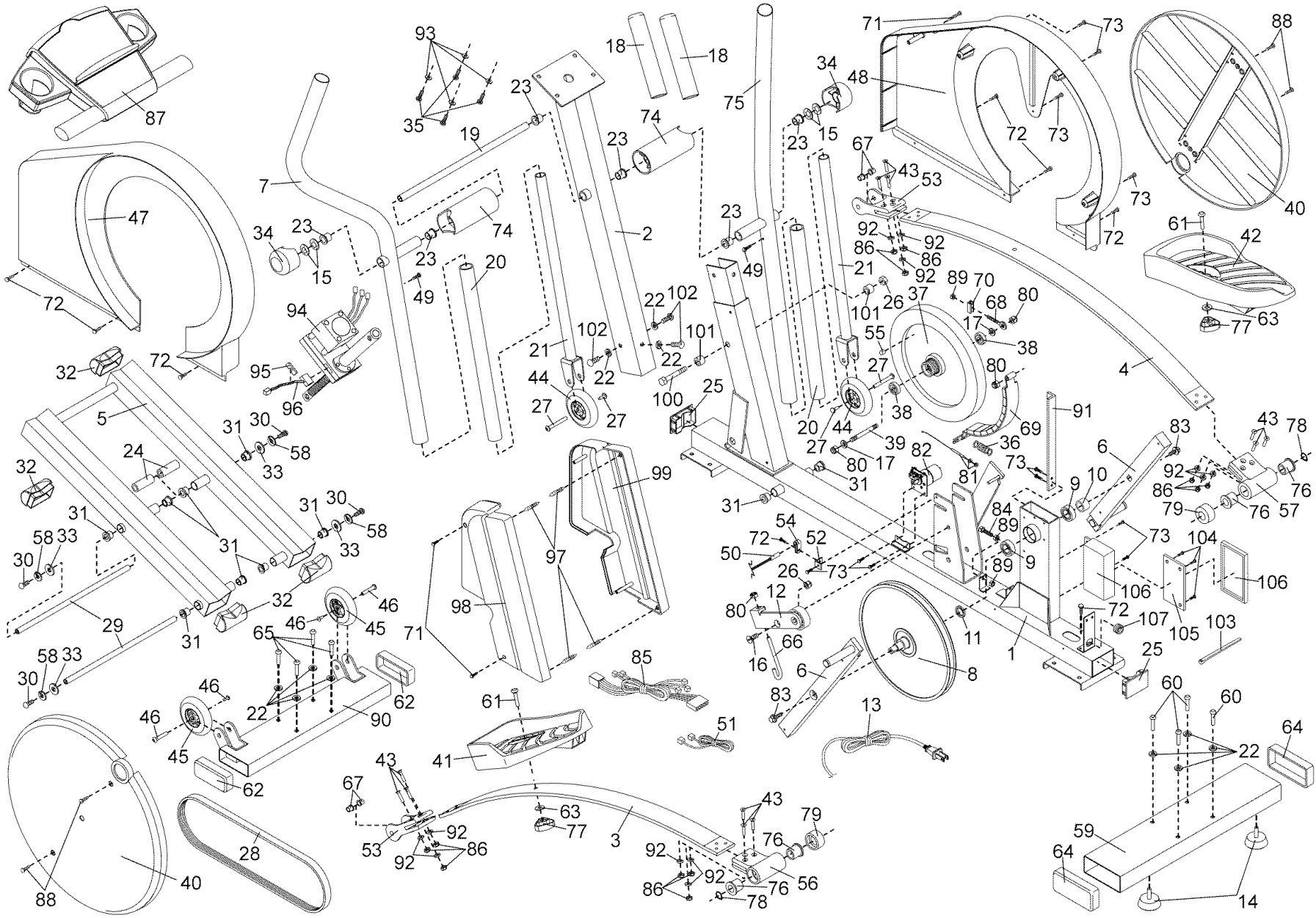

# HOW TO ORDER REPLACEMENT PARTS

To order replacement parts, simply call our Customer Service Department toll-free at 1-888-825-2588, Monday through Friday, 6 a.m. until 6 p.m. Mountain Time (excluding holidays). To help us assist you, please be prepared to give the following information when calling:

- The MODEL NUMBER of the product (831.298651)
- The NAME of the product (NordicTrack® CXT 980 elliptical crosstrainer)
- The SERIAL NUMBER of the product (see the front cover of this manual)
- The KEY NUMBER and DESCRIPTION of the part(s) from page 22 of this manual.

## LIMITED WARRANTY

**WHAT IS COVERED**—The entire NordicTrack® elliptical crosstrainer ("Product") is warranted to be free of all defects in material and workmanship.

**WHO IS COVERED**—The original purchaser or any person receiving the Product as a gift from the original purchaser.

**HOW LONG IS IT COVERED**—ICON Health & Fitness, Inc. ("ICON"), warrants the product for one year after the date of purchase. Labor is covered for one year.

**WHAT WE DO TO CORRECT COVERED DEFECTS**—We will ship to you, without charge, any replacement part or component, providing the repairs are authorized by ICON first and are performed by an ICON trained and authorized service provider, or, at our option, we will replace the Product.

**WHAT IS NOT COVERED**—Any failures or damage caused by unauthorized service, misuse, accident, negligence, improper assembly or installation, alterations, modifications without our written authorization or by failure on your part to use, operate, and maintain as set out in your User's Manual ("Manual").

**WHAT YOU MUST DO**—Always retain proof of purchase, such as your bill of sale; store, operate, and maintain the Product as specified in the Manual; notify our Customer Service Department of any defect within 10 days after discovery of the defect; as instructed, return any defected part for replacement or, if necessary, the entire product, for repair.

**USER'S MANUAL**—It is VERY IMPORTANT THAT YOU READ THE MANUAL before operating the Product. Remember to do the periodic maintenance requirements specified in the Manual to assure proper operation and your continued satisfaction.

**HOW TO GET PARTS AND SERVICE**—Simply call our Customer Service Department at 1-888-825-2588 and tell them your name and address and the serial number of your Product. They will tell you how to get a part replaced, or if necessary, arrange for service where your Product is located or advise you how to ship the Product for service. Before shipping, always obtain a Return Authorization Number (RA No.) from our Customer Service Department; securely pack your Product (save the original shipping carton if possible); put the RA No. on the outside of the carton and insure the product. Include a letter explaining the product or problem and a copy of your proof of purchase if you believe the service is covered by warranty.

ICON is not responsible or liable for indirect, special or consequential damages arising out of or in connection with the use or performance of the product or damages with respect to any economic loss, loss of property, loss of revenues or profits, loss of enjoyment or use, costs of removal, installation or other consequential damages of whatsoever nature. Some states do not allow the exclusion or limitation of incidental or consequential damages. Accordingly, the above limitation may not apply to you.

The warranty extended hereunder is in lieu of any and all other warranties and any implied warranties of merchantability or fitness for a particular purpose is limited in its scope and duration to the terms set forth herein. Some states do not allow limitations on how long an implied warranty lasts. Accordingly, the above limitation may not apply to you.

No one is authorized to change, modify or extend the terms of this limited warranty. This warranty gives you specific legal rights and you may have other rights which vary from state to state.

**ICON HEALTH & FITNESS, INC., 1500 S. 1000 W., LOGAN, UT 84321-9813**