

NordicTrack[®] *TRL 625*

Patent Pending

Model No. 831.298961

Serial No. _____

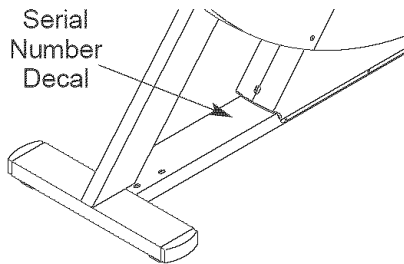

USER'S MANUAL

QUESTIONS?

As a manufacturer, we are committed to providing complete customer satisfaction. If you have questions, or if there are missing parts, we will guarantee complete satisfaction through direct assistance from our factory.

TO AVOID UNNECESSARY DELAYS, PLEASE CALL DIRECT TO OUR TOLL-FREE CUSTOMER HOT LINE. The trained technicians on our customer hot line will provide immediate assistance, free of charge to you.

CUSTOMER HOT LINE:

1-888-825-2588

Mon.-Fri., 6 a.m.-6 p.m. MST

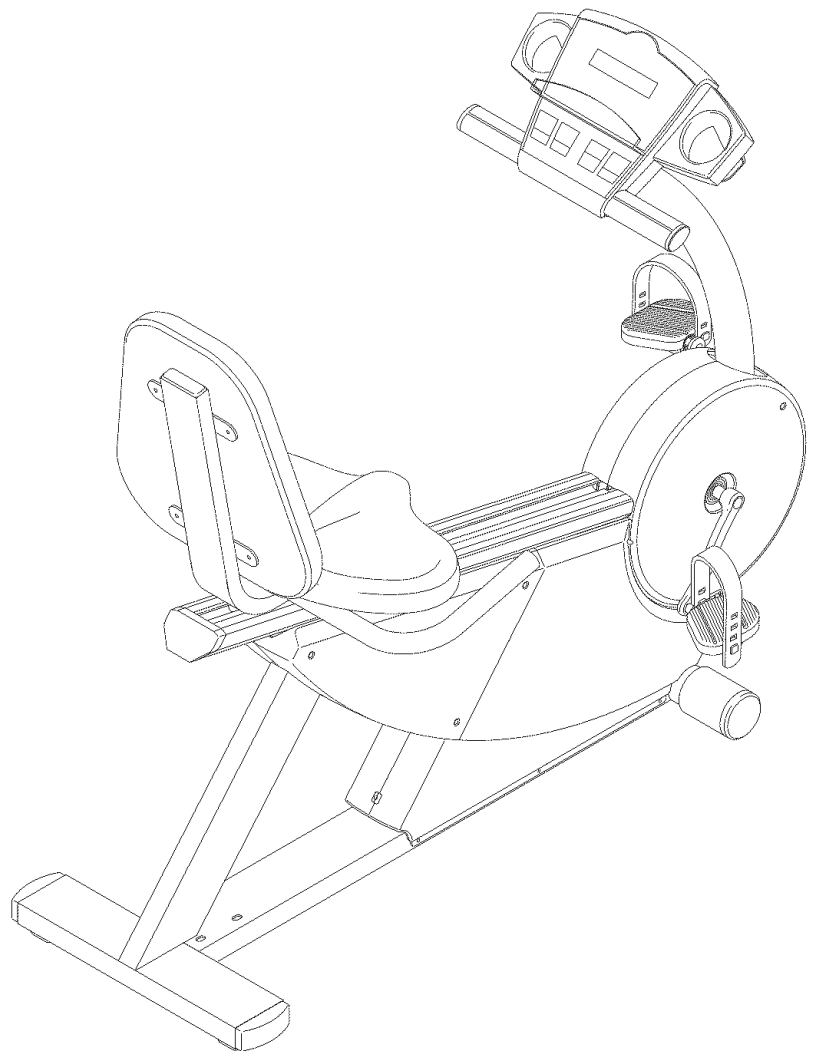

CAUTION

Read all precautions and instructions in this manual before using this equipment. Keep this manual for future reference.



Visit our website at

www.nordictrack.com

new products, prizes,
fitness tips, and much more!

TABLE OF CONTENTS

IMPORTANT PRECAUTIONS	2
BEFORE YOU BEGIN	3
ASSEMBLY	4
HOW TO OPERATE THE RECUMBENT CYCLE	9
MAINTENANCE AND TROUBLESHOOTING	12
EXERCISE GUIDELINES	13
PART LIST	14
EXPLODED DRAWING	15
HOW TO ORDER REPLACEMENT PARTS	Back Cover
LIMITED WARRANTY	Back Cover

IMPORTANT PRECAUTIONS

⚠ WARNING: To reduce the risk of serious injury, read the following important precautions before using the recumbent cycle.

1. Read all instructions in this manual before using the recumbent cycle.
2. It is the responsibility of the owner to ensure that all users of the recumbent cycle are adequately informed of all precautions. Use the recumbent cycle only as described in this manual.
3. Use the recumbent cycle indoors on a level surface. Keep the recumbent cycle away from moisture and dust. Place a mat under the recumbent cycle to protect the floor or carpet.
4. Inspect and tighten all parts regularly. Replace any worn parts immediately.
5. Keep children under the age of 12 and pets away from the recumbent cycle at all times.
6. The recumbent cycle should not be used by persons weighing more than 250 pounds.
7. Wear appropriate clothing when exercising; do not wear loose clothing that could become caught on the recumbent cycle. Always wear athletic shoes when using the recumbent cycle.
8. Always keep your back straight when using the recumbent cycle. Do not arch your back.
9. If you feel pain or dizziness while exercising, stop immediately and cool down.
10. The pulse sensor is not a medical device. Various factors, including the user's movement, may affect the accuracy of heart rate readings. The pulse sensor is intended only as an exercise aid in determining heart rate trends in general.
11. The recumbent cycle is intended for in-home use only. Do not use the recumbent cycle in a commercial, rental, or institutional setting.

⚠ WARNING: Before beginning this or any exercise program, consult your physician. This is especially important for persons over the age of 35 or persons with pre-existing health problems. Read all instructions before using. ICON assumes no responsibility for personal injury or property damage sustained by or through the use of this product.

BEFORE YOU BEGIN

Congratulations for selecting the new NordicTrack® TRL625 recumbent cycle. Cycling is one of the most effective exercises for increasing cardiovascular fitness, building endurance, and toning the entire body. The NordicTrack® TRL625 offers an impressive array of features designed to let you enjoy this healthful exercise in the comfort and privacy of your home.

For your benefit, read this manual carefully before you use the NordicTrack® TRL625. If you have additional questions, please call our Customer Service

Department toll-free at 1-888-825-2588, Monday through Friday, 6 a.m. until 6 p.m. Mountain Time (excluding holidays). To help us assist you, please mention the product model number and serial number when calling. The model number is 831.298961. The serial number can be found on a decal attached to the recumbent cycle (see the front cover of this manual for the location of the decal).

Before reading further, please familiarize yourself with the parts that are labeled in the drawing below.

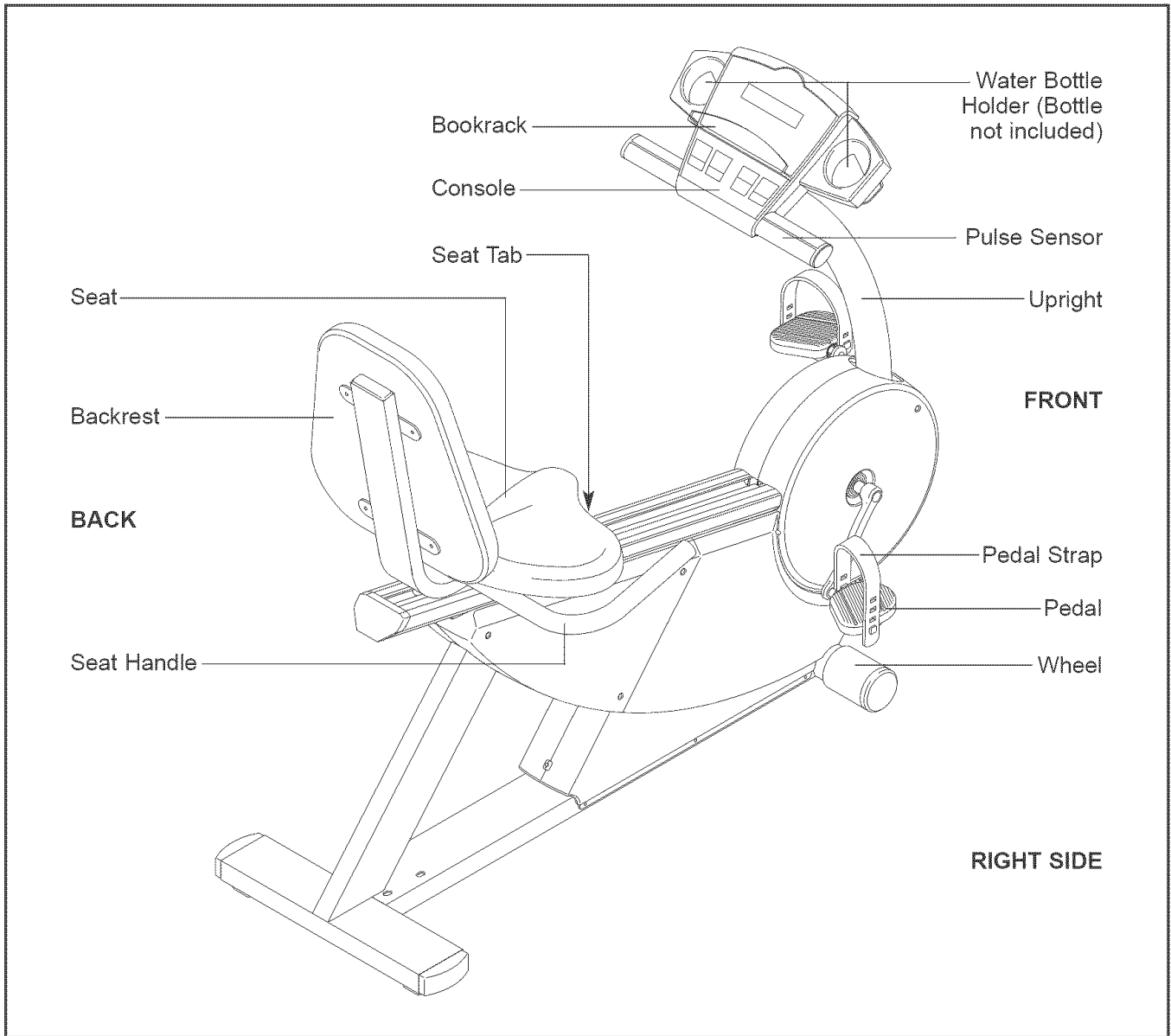

ASSEMBLY

Assembly requires two persons. Place all parts of the recumbent cycle in a cleared area and remove the packing materials. Do not dispose of the packing materials until assembly is completed.

Assembly requires the included tools and your own adjustable wrench .

Use the drawings below to identify the small parts used in assembly. The number in parenthesis below each drawing refers to the key number of the part, from the PART LIST on page 14. The second number refers to the quantity needed for assembly. **Note: Some small parts may have been pre-attached for shipping. If a part is not in the parts bag, check to see if it has been pre-assembled.**

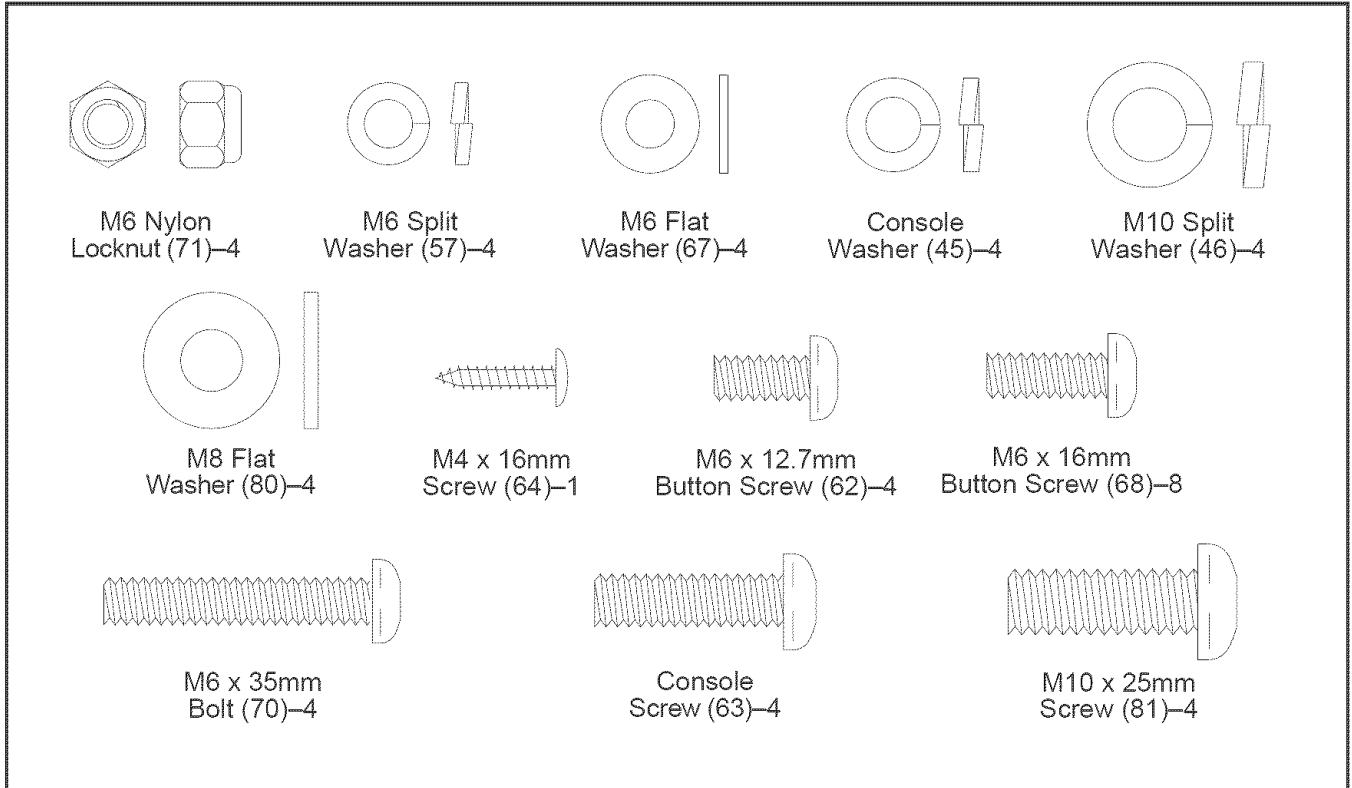

1. Attach the Stabilizer (8) to the Frame (1) with four M10 x 25mm Screws (81) and four M10 Split Washers (46).

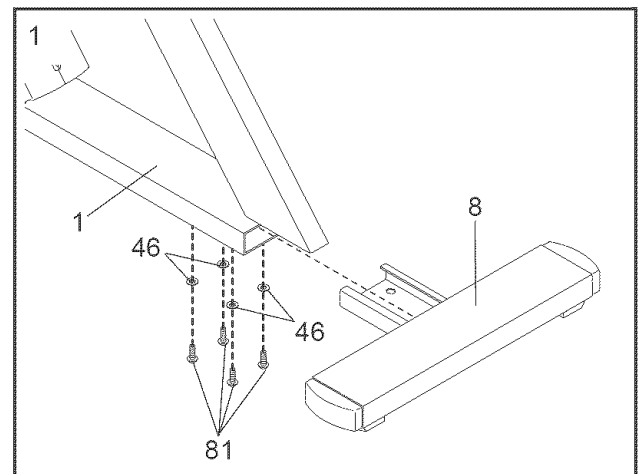

2. Connect the Extension Wire (66) to the Wire Harness (22). Attach the Upright (2) to the Frame (1) with four M6 x 12.7mm Button Screws (62), four M6 Split Washers (57), and four M6 Flat Washers (67).

Slide the Collar (48) onto the Upright (2). Align the slit in the Collar with the seam between the Side Shields (4, 5). Snap the Collar into the Side Shields.

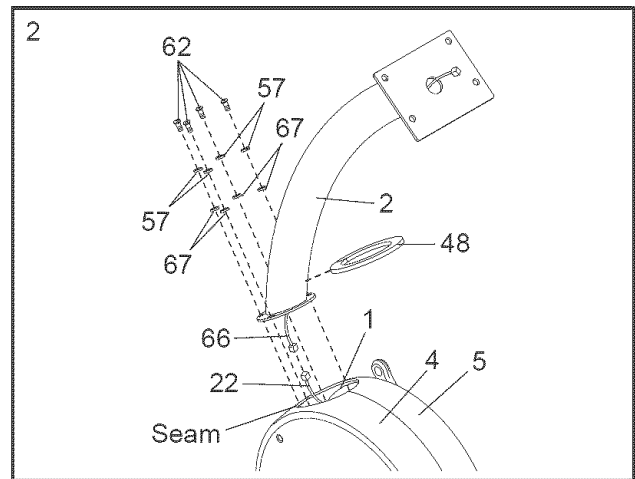

3. The Console (3) requires four "D" batteries (not included). Alkaline batteries are recommended. To install batteries, turn the Console face down and remove the battery cover, as shown in the inset drawing. Insert four batteries into the Console. **Make sure that the negative ends of the batteries (marked "—") are facing the springs in the Console.** Then, reattach the battery cover.

Connect the Extension Wire (66) to the console wire. Attach the Console (3) to the Upright (2) with four Console Washers (45) and four Console Screws (63).

Snap the bookrack onto the Console (3) in the indicated location.

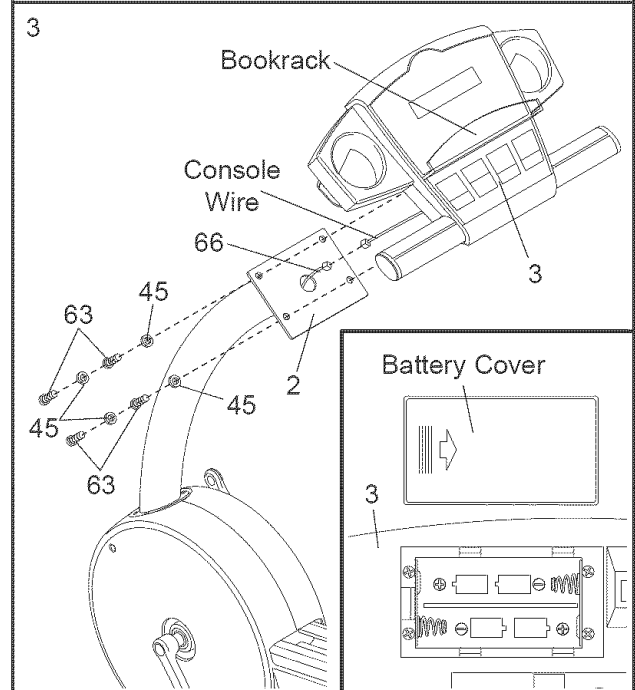

4. Attach the Handlebars (11) to the Seat Carriage (6) with four M6 x 35mm Bolts (70) and four M6 Nylon Locknuts (71).

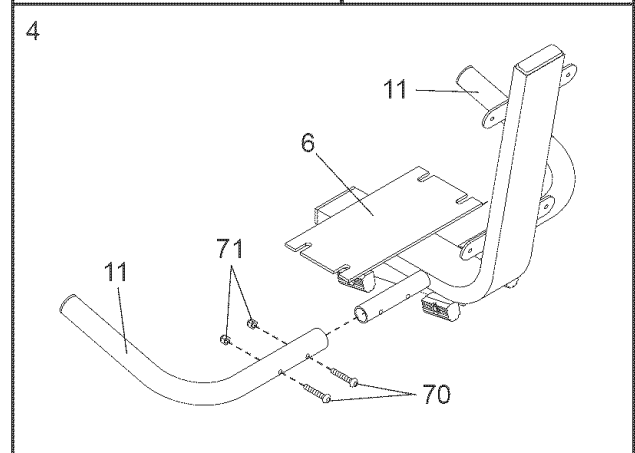

5. Attach the Seat (10) to the Seat Carriage (6) with four M6 x 16mm Button Screws (68) and four M8 Flat Washers (80).

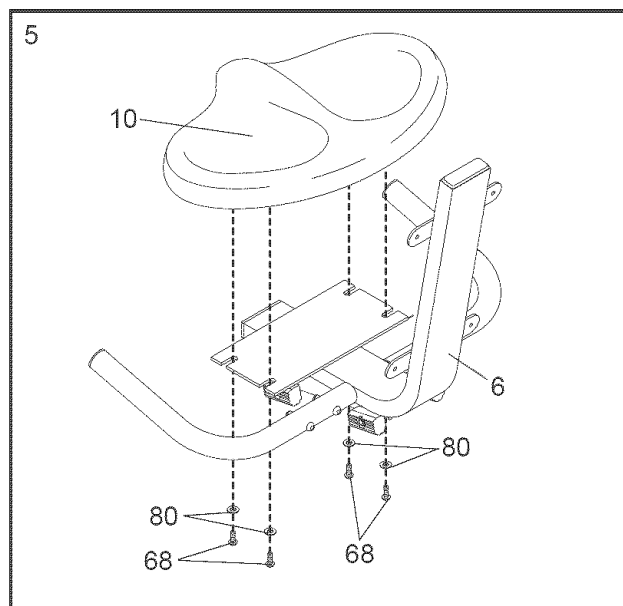

6. Attach the Backrest (9) to the Seat Carriage (6) with four M6 x 16mm Button Screws (68).

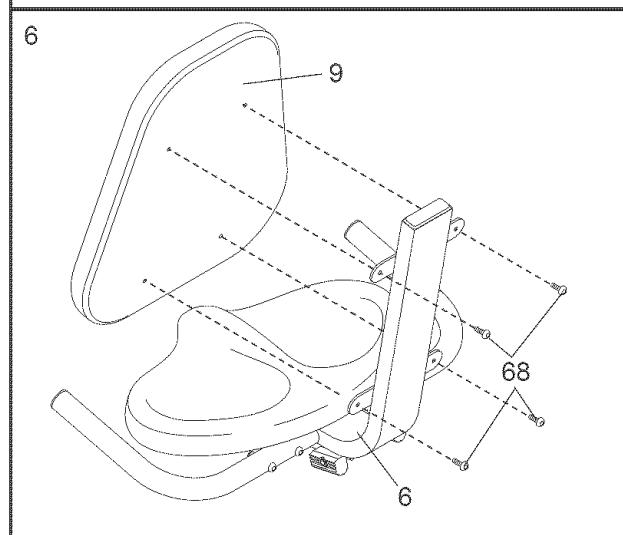

7. Hold the Seat Carriage (6) and lift the Seat Adjustment Tab (79). Slide the Seat Runners (72) into the Seat Rail (7).

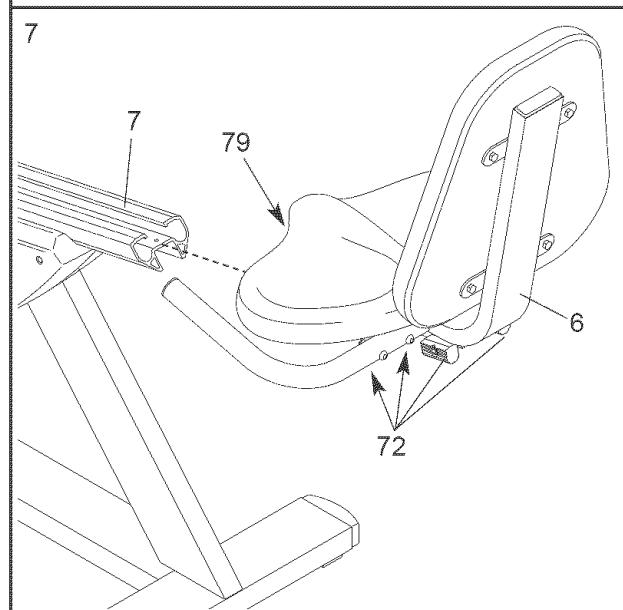

- Position the Seat Carriage (6) as shown. Slide the Seat Rail Cover (84) into the slot in the Seat Rail (7). The beveled end of the Seat Rail Cover should be flush with the end of the Seat Rail. Attach a Seat Stop (77) and the Seat Rail Cover to the Seat Rail (7) with an M4 x 16mm Screw (64).

Push the Seat Rail Cap (13) into the end of the Seat Rail.

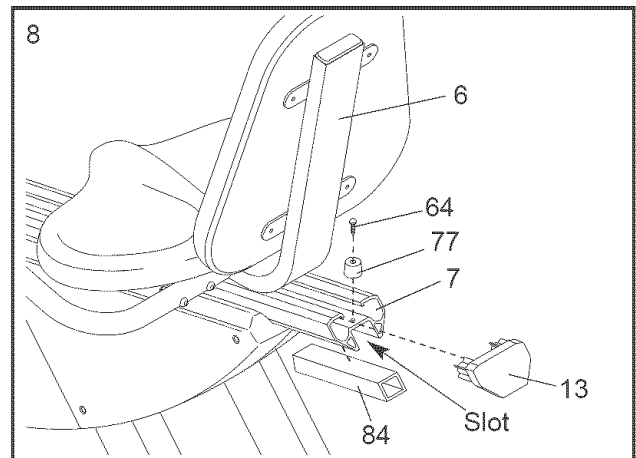

- Identify the Left Pedal (69) (there is an "L" on the Left Pedal for identification). Using an adjustable wrench, **firmly tighten** the Left Pedal counterclockwise into the Left Crank Arm (51). Tighten the Right Pedal (not shown) clockwise into the Right Crank Arm (not shown). **Tighten both Pedals as firmly as possible.**

Important: After using the recumbent cycle for one week, retighten the pedals. For best performance, the pedals must be kept properly tightened.

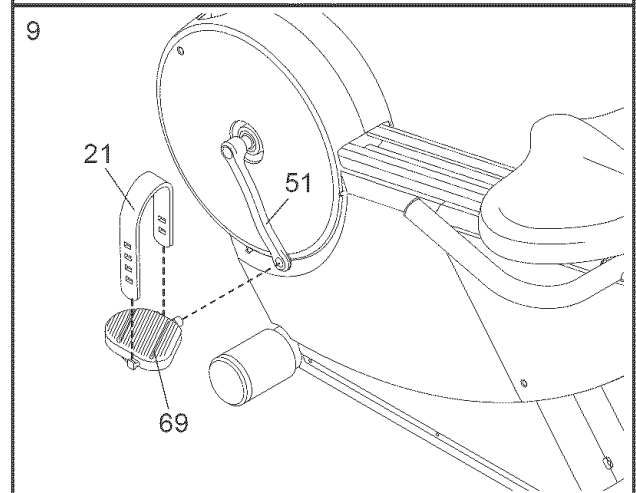

- Make sure that all parts are tightened before you use the recumbent cycle. Place a mat beneath the recumbent cycle to protect the floor.

INSTALLING THE RECEIVER FOR THE OPTIONAL CHEST PULSE SENSOR

If you purchase the optional chest pulse sensor (refer to page 11), follow the steps below to install the receiver and the short jumper wire included with the chest pulse sensor.

1. Remove the four indicated screws from the back of the Console (3). Lift the top of the Console. **Be careful not to disconnect any wires.**

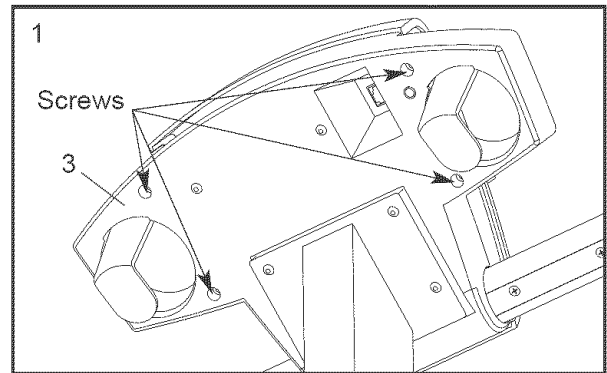

2. Peel the paper off the adhesive pad on the back of the receiver (A). Orient the receiver as shown, and press it onto the Console (3) in the indicated location.

Connect the wire on the receiver (A) to the short jumper wire (B) as shown. Plug the other end of the short jumper wire into the indicated jack (C).

Refer to step 1 above. Reattach the top of the Console (3) with the four screws. **Make sure that no wires are pinched.**

Note: Any other wires that are included with the chest pulse sensor may be discarded.

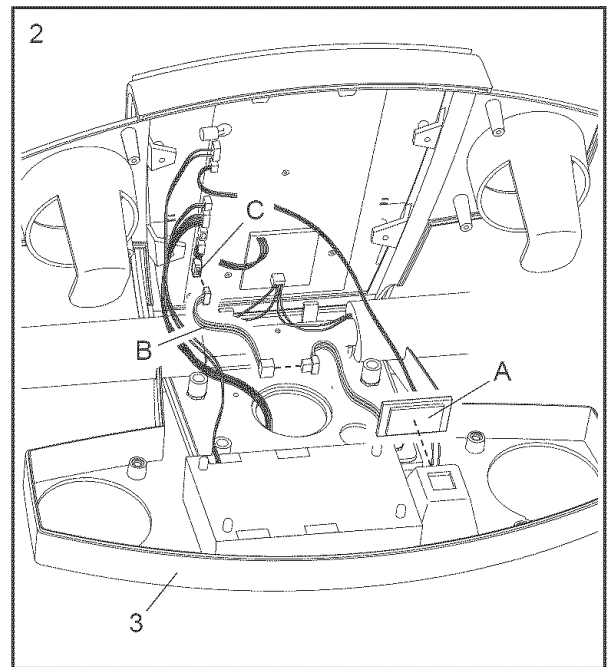

HOW TO OPERATE THE RECUMBENT CYCLE

HOW TO ADJUST THE PEDAL STRAPS

To adjust the pedal straps, first pull the straps off the tabs on the pedals. Move the straps to the desired position and press the straps back onto the tabs.

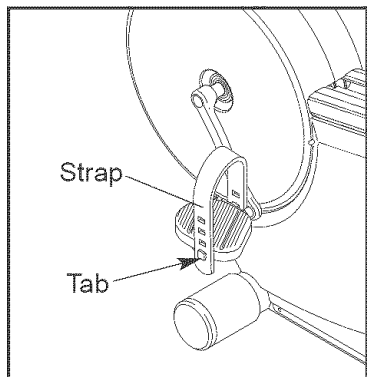

HOW TO ADJUST THE POSITION OF THE SEAT

For effective exercise, the seat should be in the proper position. As you pedal, there should be a slight bend in your knees when the pedals are the farthest away. To adjust the seat, lift the seat tab in front of the seat, slide the seat to the desired position, and then release the seat tab. **Important: After you adjust the seat, make sure that your knees will not hit the console when you pedal.**

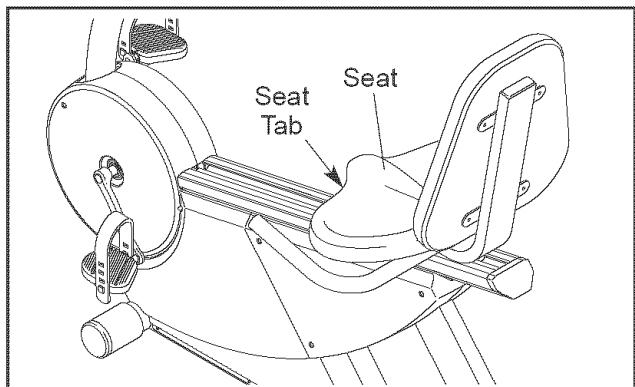

FEATURES OF THE CONSOLE

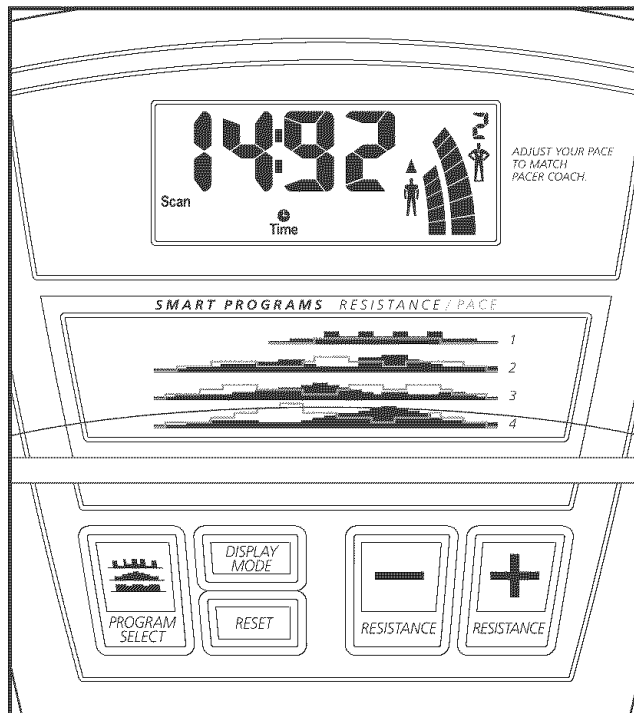

The advanced console offers a selection of features designed to make your workouts more enjoyable and effective. When the manual mode of the console is selected, the resistance of the pedals can be adjusted with a touch of a button. As you exercise, the console will provide continuous exercise feedback. You can even measure your heart rate using the built-in hand-grip pulse sensor. (For information about an optional chest pulse sensor, refer to page 11.)

The console also offers four Smart workout programs. Each program automatically changes the resistance of the pedals and prompts you to increase or decrease your pace as it guides you through an effective workout.

Note: The console requires four "D" batteries (see assembly step 3 on page 5 for battery installation instructions). If there is a thin sheet of clear plastic on the face of the console, remove it. **The console can show speed and distance in either miles or kilometers. To change the unit of measurement, hold down the Reset button for six seconds. When the batteries are replaced, it may be necessary to reselect the desired unit of measurement.**

HOW TO USE THE MANUAL MODE

1 Turn on the console.

To turn on the console, press the Reset button or begin pedaling.

2 Select the manual mode.

Each time the console is turned on, the manual mode will be selected. If a Smart program has been selected, select the manual mode by pressing the Program Select button repeatedly until the upper right corner of the display is blank.

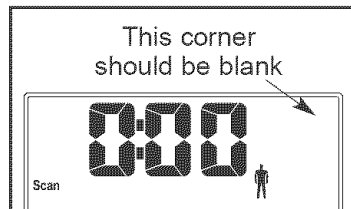

3 Begin exercising and adjust the resistance of the pedals.

As you exercise, adjust the resistance of the pedals by pressing the + and – buttons. There are ten resistance levels; level 10 is the most challenging. Note: After the buttons are pressed, it will take a few seconds for the selected setting to be reached.

4 Follow your progress with the feedback modes and the left pace indicator.

When the console is turned on, the scan mode will be selected. As you exercise, the display will show your current speed, the elapsed time, the distance that you have pedaled, the current resistance level, and the approximate numbers of calories and fat calories you have burned (see FAT BURNING on page 13). The display will also show your heart rate when you use the handgrip pulse sensor or the optional chest pulse sensor. Mode indicators will appear to show which feedback mode is currently shown. Note: Each time the resistance level changes, the console will show the resistance level for six seconds. When a Smart program is selected, the display will show the time remaining in the program instead of the elapsed time.

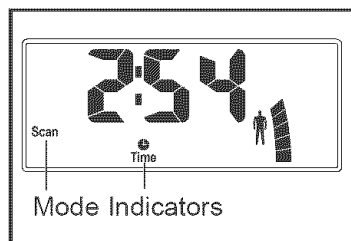

If desired, you can select a single feedback mode for continuous display. Press the Display Mode button repeatedly until only the MPH (or Km/H), Time, Miles (or Kms), Resist., Cals., or Fat Cals. indicator appears in the display. Make sure that the Scan indicator does not appear.

In addition, a pace indicator will appear in the display to show your exercise pace. As you increase or decrease your pace, the pace indicator will increase or decrease in height.

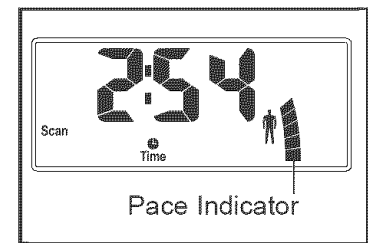

5 Measure your heart rate if desired.

Note: If you wear the optional chest pulse sensor and hold the handgrip pulse sensor at the same time, the console may not display your heart rate accurately.

If there are thin sheets of plastic on the metal contacts on the handgrip pulse sensor, peel off the plastic. To use

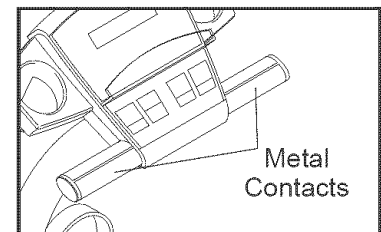

the handgrip pulse sensor, place your hands on the metal contacts, with your palms on the nearest contacts and your fingers touching the farthest contacts. Avoid moving your hands. When your pulse is detected, the heart-shaped indicator in the display will flash each time your heart beats. After a moment, two dashes (– –) will appear and then your heart rate will be shown.

For the most accurate heart rate reading, continue to hold the handgrips for about 15 seconds. Note: When you first hold the handgrips, the display will show your heart rate continuously for 15 seconds. The display will then show your heart rate along with the other feedback modes.

6 When you are finished exercising, the console will automatically turn off.

If the pedals are not moved and the console buttons are not pressed for a few minutes, the console will automatically turn off to conserve the batteries.

HOW TO USE A SMART PROGRAM

1 Turn on the console.

See step 1 on page 10.

2 Select one of the four Smart programs.

Each time the console is turned on, the manual mode will be selected. To select a Smart program, press the Program

Select button repeatedly until the number 1, 2, 3, or 4 appears in the upper right corner of the display.

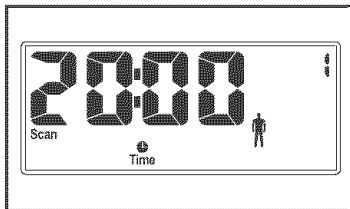

The profiles in the center of the console show how the resistance of the pedals and the target pace will change during the Smart programs. For example, profile number 3 shows that during Smart program 3, the resistance will gradually increase during the first half of the program, and then gradually decrease; the target pace will alternately increase and decrease.

3 Start the program.

To start the program, simply begin pedaling. Each Smart program consists of either twenty or thirty, one-minute periods. One resistance setting and one pace setting are programmed for each period. (The same resistance setting and/or pace setting may be programmed for consecutive periods.)

During the program, the resistance of the pedals will automatically change as shown by the applicable profile on the console. Note: If the current resistance level is too high or too low, you can change the resistance level by pressing the + and - buttons. However, when the current period of the program is completed, the resistance level will automatically change if a different resistance setting is programmed for the next period.

The target pace settings for the program will be shown by the right pace indicator in the display (see the drawing at the upper right). The left pace indicator will show your actual exercise pace. As the right pace indicator changes in height, simply adjust your pace so that both pace indicators are

at the same height. If your pace is slower than the current target pace, the increase arrow will appear in the display to prompt you to increase your pace; if your

pace is faster than the target pace, the decrease arrow will appear. **Important: The target pace settings for the program are intended only to provide a goal. Your actual pace may be slower than the target pace settings, especially during the first few months of your exercise program. Make sure to exercise at a pace that is comfortable for you.**

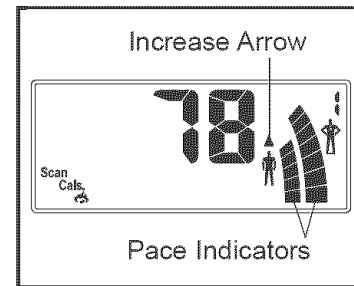

During the program, the display will show the time remaining in the program. If you continue exercising after the program is completed, the display will continue to show your exercise feedback.

4 Follow your progress with the feedback modes.

See step 4 on page 10.

5 Measure your heart rate if desired.

See step 5 on page 10.

6 When you are finished exercising, the console will automatically turn off.

See step 6 on page 10.

THE OPTIONAL CHEST PULSE SENSOR

The optional chest pulse sensor provides hands-free operation and continuously monitors your heart rate during your workouts. **To purchase the chest pulse sensor, call toll-free 1-800-734-2377.**

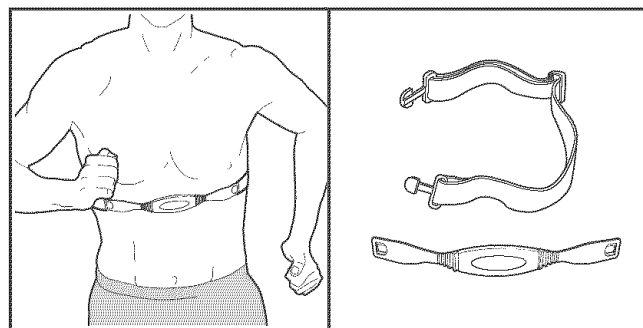

MAINTENANCE AND TROUBLESHOOTING

Inspect and properly tighten all parts of the recumbent cycle regularly. To clean the recumbent cycle, use a soft, damp cloth.

To prevent damage to the console, keep liquids away from the console, keep the console out of direct sunlight, and remove the batteries when storing the recumbent cycle.

BATTERY REPLACEMENT

If the console display becomes dim, the batteries should be replaced. Refer to assembly step 3 on page 5 for replacement instructions.

PULSE SENSOR TROUBLESHOOTING

- Avoid moving your hands while using the pulse sensor. Excessive movement may interfere with heart rate readings.
- Do not hold the metal contacts too tightly; doing so may interfere with heart rate readings.
- For the most accurate heart rate reading, hold the metal contacts for about 15 seconds.
- For optimal performance of the pulse sensor, keep the metal contacts clean. The contacts can be cleaned with a soft cloth—never use alcohol, abrasives, or chemicals.

SEAT ADJUSTMENT TROUBLESHOOTING

If the seat does not stay in place while you are pedaling, screw the Brake Pad (85) farther out of the Seat Adjustment Tab (79), down toward the Seat Rail (7).

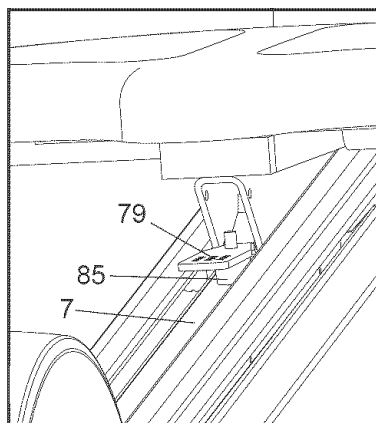

HOW TO ADJUST THE REED SWITCH

If the console does not display correct feedback, the reed switch should be adjusted. To adjust the reed switch, the Left Side Shield (4) must be removed. Using an adjustable wrench, turn the Left Pedal (69) clockwise and remove it. Next, remove the indicated Screws (64, 76). Turn the Left Crank Arm (51) so that it is pointing toward the front of the recumbent cycle and then slide off the Left Side Shield.

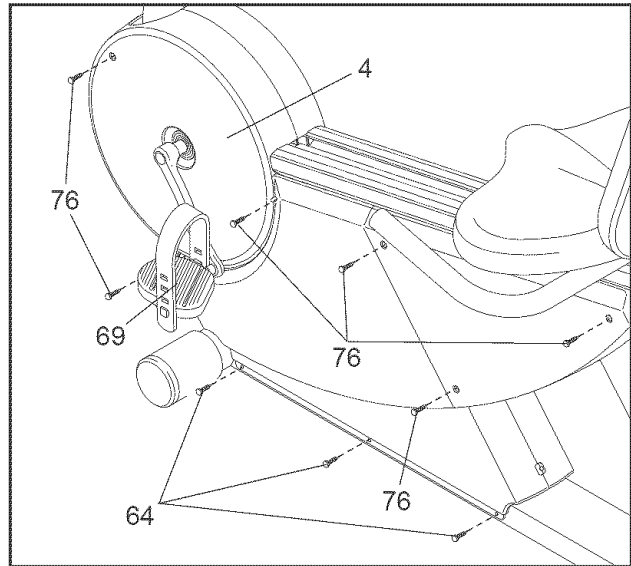

Next, locate the Reed Switch (61). Turn the Left Crank Arm (51) until the Magnet (59) is aligned with the Reed Switch. Loosen, but do not remove, the indicated Screw (64). Slide the Reed Switch slightly closer to or away from the Magnet. Retighten the Screw. Turn the Crank for a moment. Repeat until the console displays correct feedback. When the Reed Switch is correctly adjusted, reattach the left side shield and the left pedal.

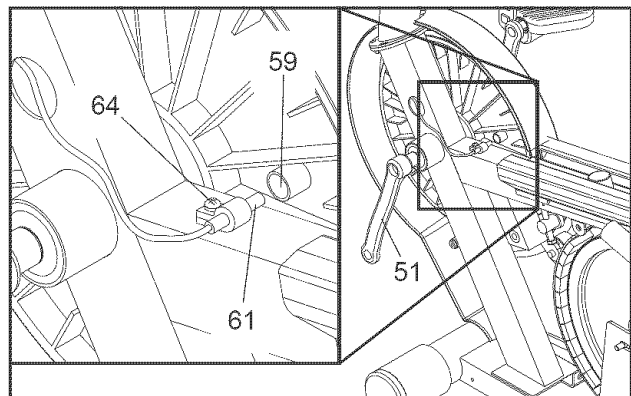

EXERCISE GUIDELINES

▲ WARNING:

- Before beginning this or any exercise program, consult your physician. This is especially important for individuals over the age of 35 or individuals with pre-existing health problems.
- The pulse sensor is not a medical device. Various factors may affect the accuracy of heart rate readings. The pulse sensor is intended only as an exercise aid in determining heart rate trends in general.

The following guidelines will help you to plan your exercise program. Remember that proper nutrition and adequate rest are essential for successful results.

EXERCISE INTENSITY

Whether your goal is to burn fat or to strengthen your cardiovascular system, the key to achieving the desired results is to exercise with the proper intensity. The proper intensity level can be found by using your heart rate as a guide. The chart below shows recommended heart rates for fat burning, maximum fat burning, and cardiovascular (aerobic) exercise.

165	155	145	140	130	125	115	♥
145	138	130	125	118	110	103	♥
125	120	115	110	105	95	90	♥
<hr/>							
20	30	40	50	60	70	80	

To find the proper heart rate for you, first find your age at the bottom of the chart (ages are rounded off to the nearest ten years). Next, find the three numbers above your age; the three numbers are your “training zone.” The lowest number is the recommended heart rate for fat burning; the middle number is the recommended heart rate for maximum fat burning; and the highest number is the heart rate for aerobic exercise.

Fat Burning

To burn fat effectively, you must exercise at a relatively low intensity level for a sustained period of time. During the first few minutes of exercise, your body uses easily accessible carbohydrate calories for energy. Only after the first few minutes of exercise does your body begin to use stored fat calories for energy. If your goal is to burn fat, adjust the intensity of your exercise until your heart rate is near the lowest number or the middle number in your training zone as you exercise.

Aerobic Exercise

If your goal is to strengthen your cardiovascular system, your exercise must be “aerobic.” Aerobic exercise is activity that requires large amounts of oxygen for prolonged periods of time. This increases the demand on the heart to pump blood to the muscles, and on the lungs to oxygenate the blood. For aerobic exercise, adjust the intensity of your exercise until your heart rate is near the highest number in your training zone.

WORKOUT GUIDELINES

Each workout should include the following three parts:

A warm-up, consisting of 5 to 10 minutes of stretching and light exercise. A proper warm-up increases your body temperature, heart rate, and circulation in preparation for exercise.

Training zone exercise, consisting of 20 to 30 minutes of exercising with your heart rate in your training zone. (During the first few weeks of your exercise program, do not keep your heart rate in your training zone for longer than 20 minutes.)

A cool-down, with 5 to 10 minutes of stretching. This will increase the flexibility of your muscles and will help to prevent post-exercise problems.

EXERCISE FREQUENCY

To maintain or improve your condition, plan three workouts each week, with at least one day of rest between workouts. After a few months of regular exercise, you may complete up to five workouts each week, if desired. The key to success is make exercise a regular and enjoyable part of your everyday life.

PART LIST—Model No. 831.298961

R0303A

Key No.	Qty.	Description	Key No.	Qty.	Description	Key No.	Qty.	Description
1	1	Frame	31	2	M5 Nut	61	1	Reed Switch
2	1	Upright	32	1	M6 x 38mm Bolt	62	4	M6 x 12.7 mm Button Screw
3	1	Console	33	4	M6 Nut	63	4	Console Screw
4	1	Left Side Shield	34	2	M10 Locknut	64	10	M4 x 16mm Screw
5	1	Right Side Shield	35	1	Flywheel Spacer	65	1	Belt
6	1	Seat Carriage	36	1	M8 x 41mm Bolt	66	1	Extension Wire
7	1	Seat Rail	37	2	Wheel Bushing	67	4	M6 Flat Washer
8	1	Rear Stabilizer	38	2	Wheel	68	8	M6 x 16mm Button Screw
9	1	Backrest	39	2	Wheel Washer	69	1	Left Pedal
10	1	Seat	40	4	Push Nut	70	4	M6 x 35mm Bolt
11	2	Handlebar	41	2	Wheel Cover	71	8	M6 Nylon Locknut
12	1	Adjustment Bracket	42	1	Wheel Axle	72	4	Seat Runner
13	1	Seat Rail Cap	43	1	Idler Assembly	73	1	M8 x 70mm Bolt
14	2	Foot	44	4	M4 x 16mm Screw	74	2	Endcap
15	2	Stabilizer Endcap	45	4	Console Washer	75	2	Handlebar Endcap
16	6	M4 x 16mm Flat Screw	46	4	M10 Split Washer	76	9	M4 x 25mm Screw
17	1	Flywheel	47	1	Pulley Washer	77	2	Seat Stop
18	1	"C" Magnet	48	1	Collar	78	1	Seat Spring
19	1	Right Pedal	49	1	Pulley	79	1	Seat Adjustment Tab
20	1	Right Pedal Strap	50	1	Right Crank Arm	80	4	M8 Flat Washer
21	1	Left Pedal Strap	51	1	Left Crank Arm	81	4	M10 x 25mm Screw
22	1	Motor/Wire Harness	52	1	Crank	82	1	M6 x 35mm Screw
23	1	Resistance Cable	53	2	Crank Cap	83	1	Seat Rail Shield
24	3	M8 Nylon Locknut	54	2	M8 x 20mm Flange Screw	84	1	Seat Rail Cover
25	1	Resistance Spring	55	2	Snap Ring	85	1	Brake Pad
26	1	M10 x 45mm Bolt	56	3	Crank Bearing	86	1	Flywheel Washer
27	2	Flywheel Bearing	57	4	M6 Split Washer	87	8	M5 x 16mm Screw
28	1	Flywheel Axle	58	1	Clutch Bearing	#	1	User's Manual
29	2	Eye Bolt	59	1	Magnet	#	1	Allen Wrench
30	2	Tension Bracket	60	1	Reed Switch Clamp			

Note: "#" indicates a non-illustrated part. Specifications are subject to change without notice. See the back cover of this manual for information about ordering replacement parts.

EXPLODED DRAWING—Model No. 831.298961

R0303A

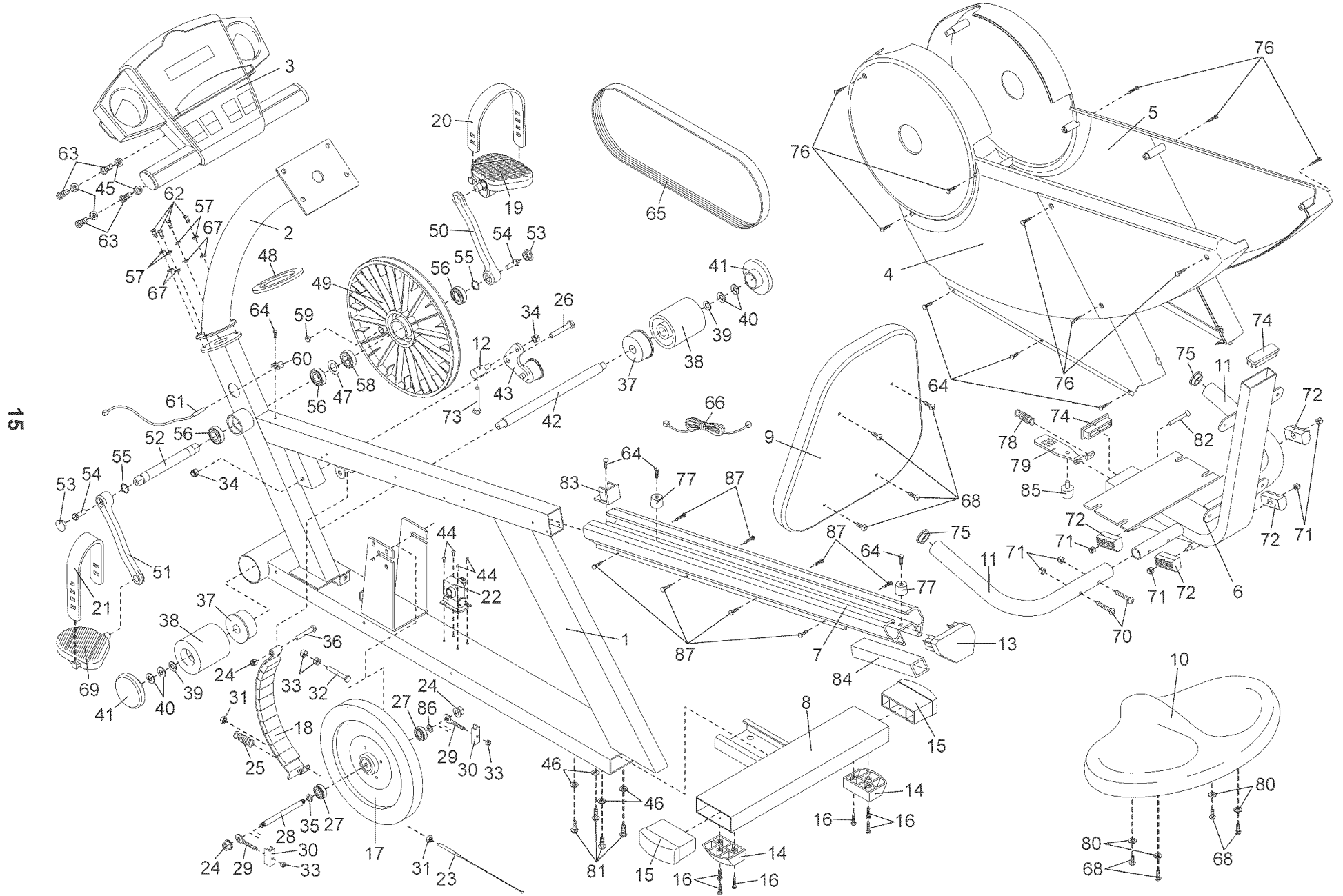

HOW TO ORDER REPLACEMENT PARTS

To order replacement parts, simply call our Customer Service Department toll-free at 1-888-825-2588, Monday through Friday, 6 a.m. until 6 p.m. Mountain Time (excluding holidays). To help us assist you, please be prepared to give the following information when calling:

- the MODEL NUMBER of the product (831.298961)
- the NAME of the product (NordicTrack® TRL625 recumbent cycle)
- the SERIAL NUMBER of the product (see the front cover of this manual)
- the KEY NUMBER and DESCRIPTION of the part(s) from page 14 of this manual

NordicTrack is a registered trademark of ICON Health & Fitness, Inc.

LIMITED WARRANTY

ICON Health & Fitness, Inc. (ICON), warrants this product to be free from defects in workmanship and material, under normal use and service conditions, for a period of ninety (90) days from the date of purchase. This warranty extends only to the original purchaser. ICON's obligation under this warranty is limited to replacing or repairing, at ICON's option, the product through one of its authorized service centers. All repairs for which warranty claims are made must be pre-authorized by ICON. This warranty does not extend to any product or damage to a product caused by or attributable to freight damage, abuse, misuse, improper or abnormal usage or repairs not provided by an ICON authorized service center, products used for commercial or rental purposes, or products used as store display models. No other warranty beyond that specifically set forth above is authorized by ICON.

ICON is not responsible or liable for indirect, special or consequential damages arising out of or in connection with the use or performance of the product or damages with respect to any economic loss, loss of property, loss of revenues or profits, loss of enjoyment or use, costs of removal, installation or other consequential damages of whatsoever nature. Some states do not allow the exclusion or limitation of incidental or consequential damages. Accordingly, the above limitation may not apply to you.

The warranty extended hereunder is in lieu of any and all other warranties and any implied warranties of merchantability or fitness for a particular purpose is limited in its scope and duration to the terms set forth herein. Some states do not allow limitations on how long an implied warranty lasts. Accordingly, the above limitation may not apply to you.

This warranty gives you specific legal rights. You may also have other rights which vary from state to state.

ICON HEALTH & FITNESS, INC., 1500 S. 1000 W., LOGAN, UT 84321-9813