



Top-Freezer Refrigerators

Safety Instructions 2, 3

Operating Instructions

Care and Cleaning 6, 7

Control Settings 4

Ice Service 5

Storage Drawer 4

Installation Instructions

Preparing to Install

the Refrigerator 8

Reversing the Door Swing . . . 9–13

Troubleshooting Tips 14–16

Normal Operating Sounds 14

Consumer Support

Consumer Support . . . Back Cover

Product Registration 17, 18

Warranty 19

**Owner's Manual and
Installation Instructions**

Models 11 and 12

**Write the model and serial
numbers here:**

Model _____

Serial _____

You can find them on a label
inside the refrigerator on the
upper left side wall.



IMPORTANT SAFETY INFORMATION. READ ALL INSTRUCTIONS BEFORE USING.

⚠ **WARNING!**

Use this appliance only for its intended purpose as described in this Owner's Manual.



SAFETY PRECAUTIONS

When using electrical appliances, basic safety precautions should be followed, including the following:

- This refrigerator must be properly installed and located in accordance with the Installation Instructions before it is used.
 - Do not allow children to climb, stand or hang on the shelves in the refrigerator. They could damage the refrigerator and seriously injure themselves.
 - Do not touch the cold surfaces in the freezer compartment, particularly when hands are damp or wet. Skin may stick to these extremely cold surfaces.
 - Do not store or use gasoline or other flammable vapors and liquids in the vicinity of this or any other appliance.
 - In refrigerators with automatic icemakers, avoid contact with the moving parts of the ejector mechanism, or with the heating element that releases the cubes. Do not place fingers or hands on the automatic icemaking mechanism while the refrigerator is plugged in.
 - Keep fingers out of the "pinch point" areas; clearances between the doors and between the doors and cabinet are necessarily small. Be careful closing doors when children are in the area.
 - Unplug the refrigerator before cleaning and making repairs.
- NOTE:** We strongly recommend that any servicing be performed by a qualified individual.
- Turning the control to the **OFF** position does not remove power to the light circuit.
 - Do not refreeze frozen foods which have thawed completely.

⚠ **DANGER! RISK OF CHILD ENTRAPMENT**

PROPER DISPOSAL OF THE REFRIGERATOR

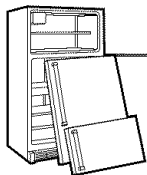

Child entrapment and suffocation are not problems of the past. Junked or abandoned refrigerators are still dangerous...even if they will sit for "just a few days." If you are getting rid of your old refrigerator, please follow the instructions below to help prevent accidents.

Before You Throw Away Your Old Refrigerator or Freezer:

- Take off the doors.
- Leave the shelves in place so that children may not easily climb inside.

Refrigerants

All refrigeration products contain refrigerants, which must be removed prior to product disposal. If you are getting rid of an old refrigeration product, check with the company handling the disposal about what to do.

USE OF EXTENSION CORDS

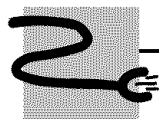

Because of potential safety hazards under certain conditions, we strongly recommend against the use of an extension cord.

However, if you must use an extension cord, it is absolutely necessary that it be a UL-listed (in the United States) or a CSA-listed (in Canada), 3-wire grounding type appliance extension cord having a grounding type plug and outlet and that the electrical rating of the cord be 15 amperes (minimum) and 120 volts.

⚠ WARNING!

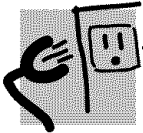

HOW TO CONNECT ELECTRICITY

Do not, under any circumstances, cut or remove the third (ground) prong from the power cord. For personal safety, this appliance must be properly grounded.

The power cord of this appliance is equipped with a 3-prong (grounding) plug which mates with a standard 3-prong (grounding) wall outlet to minimize the possibility of electric shock hazard from this appliance.

Have the wall outlet and circuit checked by a qualified electrician to make sure the outlet is properly grounded.

Where a standard 2-prong wall outlet is encountered, it is your personal responsibility and obligation to have it replaced with a properly grounded 3-prong wall outlet.

The refrigerator should always be plugged into its own individual electrical outlet which has a voltage rating that matches the rating plate.

This provides the best performance and also prevents overloading house wiring circuits which could cause a fire hazard from overheated wires.

Never unplug your refrigerator by pulling on the power cord. Always grip plug firmly and pull straight out from the outlet.

Repair or replace immediately all power cords that have become frayed or otherwise damaged. Do not use a cord that shows cracks or abrasion damage along its length or at either end.

When moving the refrigerator away from the wall, be careful not to roll over or damage the power cord.

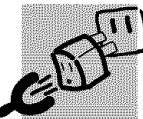

USE OF ADAPTER PLUGS

Because of potential safety hazards under certain conditions, we strongly recommend against the use of an adapter plug.

However, if you must use an adapter, where local codes permit, a **temporary connection** may be made to a properly grounded 2-prong wall outlet by use of a UL-listed adapter available at most local hardware stores.

The larger slot in the adapter must be aligned with the larger slot in the wall outlet to provide proper polarity in the connection of the power cord.

When disconnecting the power cord from the adapter, always hold the adapter in place with one hand while pulling the power cord plug with the other hand. If this is not done, the adapter ground terminal is very likely to break with repeated use.

If the adapter ground terminal breaks, **DO NOT USE** the refrigerator until a proper ground has been established.

Attaching the adapter ground terminal to a wall outlet cover screw does not ground the appliance unless the cover screw is metal, and not insulated, and the wall outlet is grounded through the house wiring. You should have the circuit checked by a qualified electrician to make sure the outlet is properly grounded.



READ AND FOLLOW THIS SAFETY INFORMATION CAREFULLY.

SAVE THESE INSTRUCTIONS

About the control on the refrigerator.

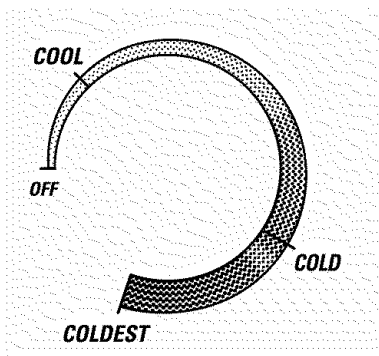

The temperature control on your refrigerator regulates the temperature in the fresh food and freezer compartments. Initially set the control at **COOL**.

Adjust the control one increment at a time, and allow 12 hours after each adjustment for the refrigerator to reach the temperature you set.



Control Settings

The temperature control maintains the temperature in both the fresh food and freezer compartments. Setting the control at **COOL** is the warmest setting. Setting the control at **COLDEST** is the coldest setting. Moving the control to the **OFF** position stops cooling in both areas—fresh food and freezer—but does not shut off power to the refrigerator.

After changing the control, allow 12 hours for the refrigerator to reach the temperature you have set.

Control settings will vary based on personal preferences, usage and operating conditions, and may require more than one adjustment.

About the storage drawer.

Fruit and Vegetable Drawer

This storage drawer provide space to store fruits, vegetables and meats.

The drawer has a divider to separate meats and vegetables. The divider can be removed if a single large storage space is needed.

The drawer will stop before coming all the way out of the refrigerator to help prevent contents from spilling onto the floor. It can be removed easily by lifting up slightly and pulling past the “stop” position.

To replace the drawer and the cover above it, the door must be fully opened. In some installations, the refrigerator may have to be moved away from the wall for the door to be fully opened.

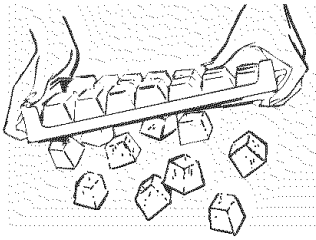

Ice Trays

To release ice cubes, turn the tray upside down, hold it over a container and twist both ends.

For only one or two ice cubes, leave the tray right-side up, twist both ends slightly and remove as many cubes as you want.

Wash ice trays in lukewarm water only—do not put them in an automatic dishwasher.

Icemaker Accessory Kit (Model 12 only)

An icemaker accessory kit is available from your dealer. Check the back of the refrigerator for the specific icemaker kit needed for your model.

Water Supply Kits (Model 12 only)

Kits containing copper tubing, shutoff valve, fittings and instructions needed to connect the icemaker to your cold water line are available at extra cost from your dealer or from Parts and Accessories. In the U.S., call 800.626.2002.

Care and cleaning of the refrigerator.

Cleaning the Outside

Keep the outside clean. Wipe with a clean cloth lightly dampened with mild liquid dish detergent. Dry with a clean, soft cloth.

Do not wipe the refrigerator with a soiled dish cloth or wet towel. These may leave a residue that can erode the paint. Do not use scouring pads, powdered cleaners, bleach or cleaners containing bleach because these products can scratch and weaken the paint finish.

Protect the paint finish. The finish on the outside of the refrigerator is a high quality, baked-on paint finish. With proper care, it will stay new-looking and rust free for years. Apply a coat of kitchen/appliance wax when the refrigerator is new, and then at least twice a year.

Cleaning the Inside

To help prevent odors, leave an open box of baking soda in the fresh food and freezer compartments.

Unplug the refrigerator before cleaning. If this is not practical, wring excess moisture out of sponge or cloth when cleaning around switches, lights or controls.

Use warm water and baking soda solution—about a tablespoon (15 ml) of baking soda to a quart (1 liter) of water. This both cleans and neutralizes odors. Rinse and wipe dry.

Other parts of the refrigerator—including door gaskets, fruit and vegetable drawers, and all plastic parts—can be cleaned the same way.

After cleaning the door gaskets, apply a thin layer of petroleum jelly to the door gaskets at the hinge side. This helps keep the gaskets from sticking and bending out of shape. Do not use cleansing powders or other abrasive cleaners.

Defrost water pan. The non-removable pan is located under the compressor at the rear of the refrigerator. It should be cleaned at least once a year. Move the refrigerator out from the wall as far as necessary, and unplug the power cord from the wall outlet. Let the compressor cool before cleaning the pan. Use a clean cloth or sponge dampened in warm water and baking soda solution—one tablespoon (15 ml) of baking soda to a quart (1 liter) of water. **Do not use** cleansing powders, abrasive cleaners, bleach or cleaners containing chlorides.

Do not wash any plastic refrigerator parts in the dishwasher.

Behind the Refrigerator

Once a year, move the refrigerator out and vacuum the back coils. Be careful when moving the refrigerator away from the wall. All types of floor coverings can be damaged, particularly cushioned coverings and those with embossed surfaces.

Pull the refrigerator straight out and return it to position by pushing it straight in. Moving the refrigerator in a side direction may result in damage to the floor covering or refrigerator.

When pushing the refrigerator back, make sure you don't roll over the power cord.

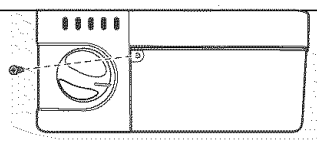

Replacing the Light Bulb

Moving the control to **OFF** does not remove power to the light circuit.

The bulb is located behind the shield next to the control.

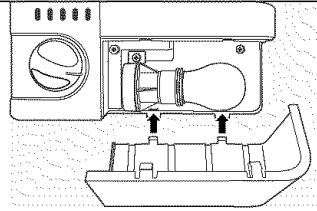

- 1 Unplug the refrigerator.
- 2 Remove the screw.
- 3 Push in near the top of the shield and rotate down and out.
- 4 Replace the bulb with an appliance bulb of the same or lower wattage (40 Watt maximum).

- 5 Insert the tabs at the bottom of the light shield with the slots in the bulb housing.
- 6 Rotate the shield up until the tabs at the top of the shield pop into place in the bulb housing.
- 7 Replace the screw.

Preparing for Vacation

For long vacations or absences, remove food and unplug the refrigerator. Move the control to the **OFF** position, and clean the interior with a baking soda solution of one tablespoon (15 ml) of baking soda to one quart (1 liter) of water. Leave the doors open.

Preparing to Move

Secure all loose items such as shelves and drawers by taping them securely in place to prevent damage.

Be sure the refrigerator stays in an upright position during moving.

Installation Instructions

Refrigerator

Models 11 and 12

If you have questions, call 1.800.GE.CARES or visit our Website at: www.GEAppliances.com

BEFORE YOU BEGIN

Read these instructions completely and carefully.

- **IMPORTANT** — Save these instructions for local inspector's use.
- **IMPORTANT** — Observe all governing codes and ordinances.
- **Note to Installer** — Be sure to leave these instructions with the Consumer.
- **Note to Consumer** — Keep these instructions for future reference.
- Skill level — Installation of this appliance requires basic mechanical skills.
- Completion time — Refrigerator Installation
15 minutes
Reversing the Door Swing
1 hour
- Proper installation is the responsibility of the installer.
- Product failure due to improper installation is not covered under the Warranty.

REFRIGERATOR LOCATION

- Do not install the refrigerator where the temperature will go below 55°F (13°C) because it will not run often enough to maintain proper temperatures.
- Install it on a floor strong enough to support it fully loaded.
- Do not install it closer than 5" (13 cm) next to a range.

CLEARANCES

Allow the following clearances for ease of installation, proper air circulation and plumbing and electrical connections.

- Sides 1" (2.5 cm)
- Top 4" (10.2 cm)
- Back 2" (5 cm) from the coiling on the back to the wall

To help with proper spacing and ventilation, make sure the metal spacer or twist-on rubber bumper (at the back of some models) is in place.

LEVELING LEGS

Adjustable legs at the front corners of the refrigerator should be set so the refrigerator is firmly positioned on the floor, and the front is raised just enough that the door closes easily when opened about halfway.

To adjust the leveling legs, turn the legs clockwise to raise the refrigerator; counterclockwise to lower it.

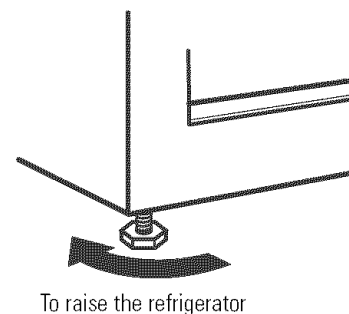

Installation Instructions

REVERSING THE DOOR SWING

IMPORTANT NOTES

When reversing the door swing:

- Read the instructions all the way through before starting.
- Handle parts carefully to avoid scratching paint.
- Set screws down by their related parts to avoid using them in the wrong places.
- Provide a non-scratching work surface for the doors.

IMPORTANT: Once you begin, do not move the cabinet until door-swing reversal is completed.

These instructions are for changing the hinges from the right side to the left side—if you ever want to change the hinges back to the right side, follow these same instructions and reverse all references to left and right.

Unplug the refrigerator from its electrical outlet.

Empty all door shelves.

TOOLS YOU WILL NEED



5/16" Socket driver

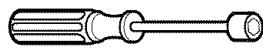

3/8" Socket driver



Phillips screwdriver

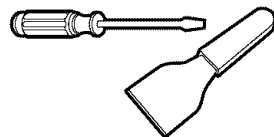

Putty knife or
thin-blade screwdriver



Masking tape

1 REMOVE THE FREEZER DOOR

Remove the hinge cover screws (some models have lock washers with each screw), top hinge and shim.

Set the door on a non-scratching surface with the outside up.

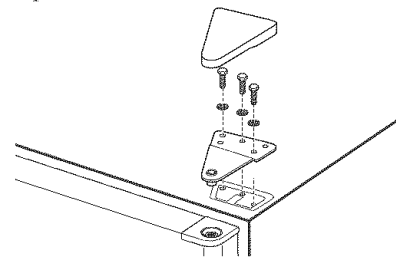

NOTE: When removing the door, watch for washer(s) between the center hinge and the bottom of the freezer door that may stick to the door. Do not lose.

CAUTION: Do not let door drop to the floor. To do so could damage the door stop.

Installation Instructions

REVERSING THE DOOR SWING (CONT.)

2 REMOVE THE FRESH FOOD DOOR

Tape the door shut with masking tape.

Remove the center hinge and shim by removing the screws (some models have lock washers with each screw). Lift up the hinge to remove it.

NOTE: Some models have a washer between the center hinge and the top of the fresh food door. Do not lose.

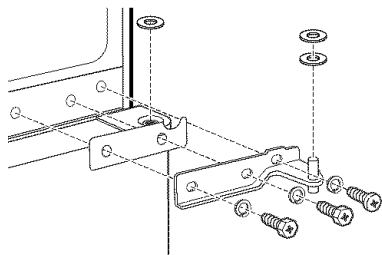

Remove the tape holding the door shut.

Lift the fresh food door up and off the bottom hinge.

Set the door outside-up on a non-scratching surface. Make sure the butter bin does not swing open.

NOTE: When removing the door, watch for washer(s) between the bottom hinge and the bottom of the fresh food door that may stick to the door. Do not lose.

▲ CAUTION: Do not let door drop to the floor. To do so could damage the door stop.

3 TRANSFER TOP HINGE TO THE LEFT

Using a putty knife with the edge covered with masking tape, remove the plug buttons. Be careful of the paint finish.

Reinstall the plug button on the right side by inserting it into the holes vacated by the top hinge screws.

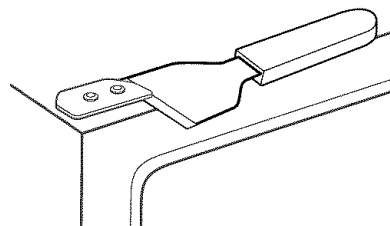

Reassemble the top hinge and shim on the left side, turning the screws just enough to hold the hinge in place.

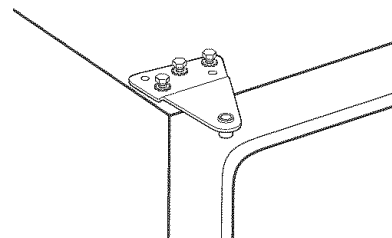

Installation Instructions

4 TRANSFER BOTTOM HINGE TO THE LEFT

To access the bottom hinge, move the refrigerator so it is 30" from a wall. Then carefully tip the refrigerator back until it rests against the wall.

CAUTION: Be sure that the coils on the back of the refrigerator do not rest against the wall. Doing so could damage the coils.

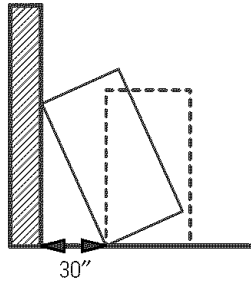

Remove the screws (some models have washers with each screw), leveling leg and bottom hinge from the right side. Remove the leveling leg from the left side of the cabinet and install it in the right side.

Reassemble the bottom hinge on the left side.

NOTE: The leveling legs are not interchangeable.

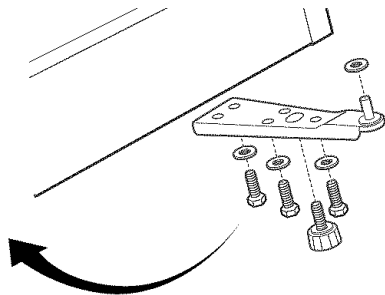

5 TRANSFER FRESH FOOD DOOR HANDLE TO THE RIGHT (CONT.)

After removing the handle: Remove the plug buttons from the right edge of the door top and insert them into the handle screw holes on the left side.

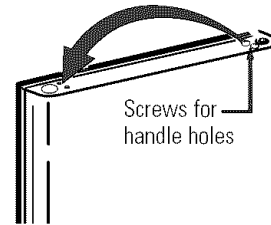

Remove the plug button from the left edge of the door and insert it into the hole on the opposite side.

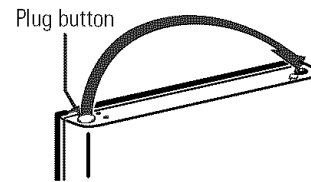

Transfer the button on the door to the opposite side.

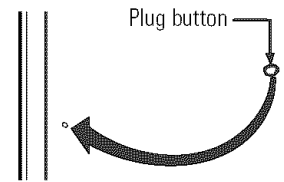

Install the handle on the other side of the door.

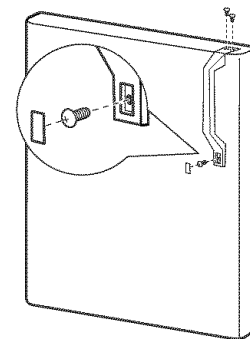

5 TRANSFER FRESH FOOD DOOR HANDLE TO THE RIGHT

For models without a handle, continue to Step 6.

To remove the handle: Remove the plug button by carefully prying under the edge with a putty knife. Remove the exposed screw holding the handle.

Remove the two screws holding the handle to the top of the door.

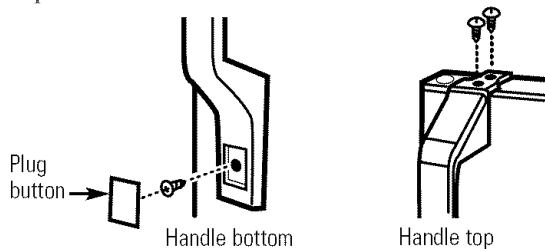

Installation Instructions

REVERSING THE DOOR SWING (CONT.)

6 TRANSFER FRESH FOOD DOOR STOP TO THE LEFT

Remove the door stop from the bottom of the right side of the door. Transfer the plug buttons from the bottom left side to the right side.

Install the door stop on the left side.

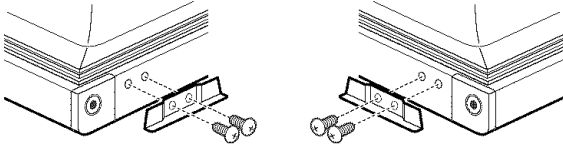

8 TRANSFER FREEZER DOOR STOP TO THE LEFT

Remove the door stop from the bottom of the right side of the door. Transfer the plug buttons from the bottom left side to the right side.

Install the door stop on the left side.

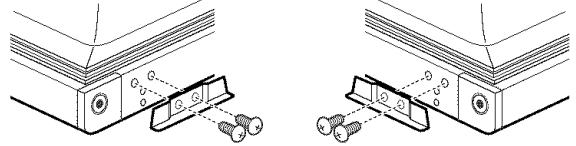

7 REMOVE FREEZER DOOR HANDLE FROM THE LEFT

For models without a handle, continue to Step 8.

Remove the nameplate plug button by carefully prying under the edge with a putty knife. Remove the exposed screw holding the handle.

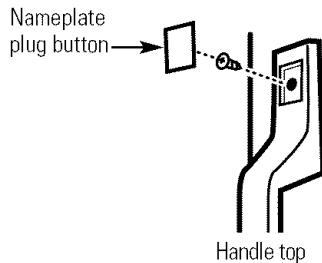

Remove the two screws holding the handle to the bottom of the door and remove the handle.

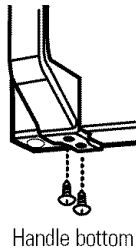

9 ATTACH FREEZER DOOR HANDLE TO THE RIGHT

For models without a handle, continue to Step 10.

Transfer the plug button on top of the door to the opposite side.

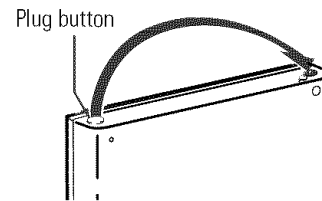

Transfer the button on the door front to the opposite side.

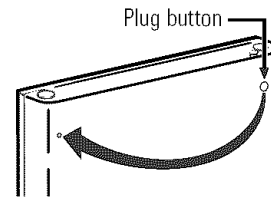

Install the handle on the other side of the door.

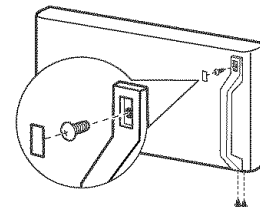

Installation Instructions

10 REHANG THE FRESH FOOD DOOR

Make sure the washer(s) are in place on the bottom hinge pin. Place the fresh food door on the bottom hinge, close the door and tape it in place with masking tape.

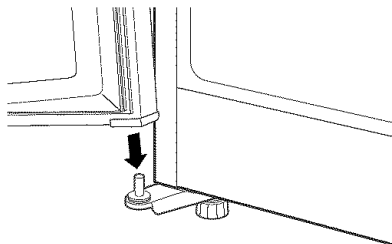

12 REHANG THE FREEZER DOOR

Place the freezer door on the center hinge over the pin.

Raise the top hinge by hand and insert the top hinge pin into the hole in the door. Then swing the door shut.

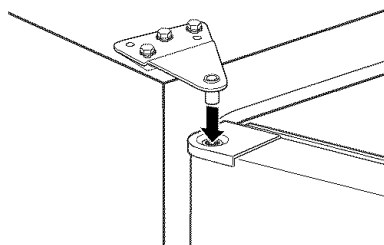

11 INSTALL CENTER HINGE ON THE LEFT

Remove the three plug buttons on the left side and install them on the right.

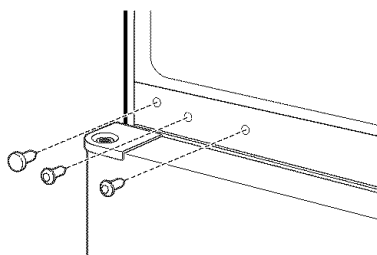

Install the center hinge designed for the left side that came with the refrigerator, with the screws, spacer and washer(s) (on some models) that you removed in Step 2.

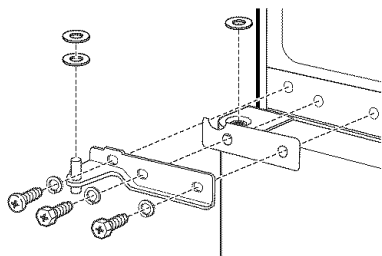

Remove the tape holding the door shut.

CAUTION: When assembled correctly, the hinge is tight against the cabinet.

ATTENTION: The screws must be properly tightened. Turn the screws until snug. Then tighten the screws a minimum of 1/2 turn using both hands.

13 ALIGN THE DOORS

Align the freezer door with the fresh food door so that the gap between the doors is even.

Tighten the top hinge screws by turning them until snug. Then turn the screws a minimum of 1/2 turn using both hands.

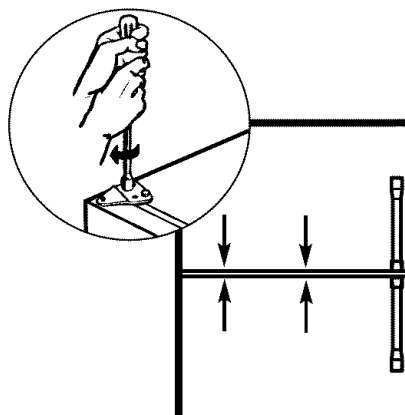

Install the hinge cover over the top hinge.

Normal operating sounds.



Newer refrigerators sound different from older refrigerators. Modern refrigerators have more features and use newer technology.

Do you hear what I hear? These sounds are normal.

**HUMMM...
WHOOSH...**

- The new high efficiency compressor may run faster and longer than your old refrigerator and you may hear a high-pitched hum or pulsating sound while it is operating.
- You may hear a whooshing sound when the doors close. This is due to pressure equalizing within the refrigerator.



- You may hear the fans spinning at high speeds. This happens when the refrigerator is first plugged in, when the doors are opened frequently or when a large amount of food is added to the refrigerator or freezer compartments. The fans are helping to maintain the correct temperatures.

CLICKS, POPS, CRACKS and CHIRPS

- You may hear cracking or popping sounds when the refrigerator is first plugged in. This happens as the refrigerator cools to the correct temperature.
- The compressor may cause a clicking or chirping sound when attempting to restart (this could take up to 5 minutes).
- Expansion and contraction of cooling coils during and after defrost can cause a cracking or popping sound.
- On models with an icemaker, after an icemaking cycle, you may hear the ice cubes dropping into the ice bucket.

WATER SOUNDS



- The flow of refrigerant through the freezer cooling coils may make a gurgling noise like boiling water.
- Water dropping on the defrost heater can cause a sizzling, popping or buzzing sound during the defrost cycle.
- A water dripping noise may occur during the defrost cycle as ice melts from the evaporator and flows into the drain pan.
- Closing the door may cause a gurgling sound due to pressure equalization.



Troubleshooting Tips
 Save time and money! Review the charts on the following pages first and you may not need to call for service.

| Problem | Possible Causes | What To Do |
|---|---|---|
| Refrigerator does not operate | Refrigerator in defrost cycle. | • Wait about 30 minutes for defrost cycle to end. |
| | Control in OFF position. | • Move the control to a temperature setting. |
| | Refrigerator is unplugged. | • Push the plug completely into the outlet. |
| | The fuse is blown/circuit breaker is tripped. | • Replace fuse or reset the breaker. |
| Vibration or rattling (slight vibration is normal) | Front leveling legs need adjusting. | • See <i>Leveling Legs</i> . |
| Motor operates for long periods or cycles on and off frequently. (Modern refrigerators with more storage space and a larger freezer require more operating time. They start and stop often to maintain even temperatures.) | Normal when refrigerator is first plugged in. | • Wait 24 hours for the refrigerator to completely cool down. |
| | Often occurs when large amounts of food are placed in refrigerator. | • This is normal. |
| | Door left open. | • Check to see if package is holding door open. |
| | Hot weather or frequent door openings. | • This is normal. |
| | Temperature control set at the coldest setting. | • See <i>About the control</i> . |
| Fresh food or freezer compartment too warm | Temperature control not set cold enough. | • See <i>About the control</i> . |
| | Warm weather or frequent door openings. | • Set the temperature control one step colder. See <i>About the control</i> . |
| | Door left open. | • Check to see if package is holding door open. |
| Frost or ice crystals on frozen food (frost within package is normal) | Door left open. | • Check to see if package is holding door open. |
| | Too frequent or too long door openings. | |
| Ice cubes have odor/taste | Food transmitting odor/taste to ice cubes. | • Wrap foods well. |
| | Interior of refrigerator needs cleaning. | • See <i>Care and cleaning</i> . |
| Slow ice cube freezing | Door left open. | • Check to see if package is holding door open. |
| | Temperature control not set cold enough. | • See <i>About the control</i> . |

Before you call for service...



Troubleshooting Tips

| Problem | Possible Causes | What To Do |
|--|--|--|
| Refrigerator has odor | Foods transmitting odor to refrigerator. | <ul style="list-style-type: none"> • Foods with strong odors should be tightly wrapped. • Keep an open box of baking soda in the refrigerator; replace every three months. |
| | Interior needs cleaning. | <ul style="list-style-type: none"> • See <i>Care and cleaning</i>. |
| | Defrost water pan needs cleaning. | <ul style="list-style-type: none"> • See <i>Care and cleaning</i>. |
| Moisture forms on outside of refrigerator | Not unusual during periods of high humidity. | <ul style="list-style-type: none"> • Wipe surface dry. |
| Moisture collects inside (in humid weather, air carries moisture into refrigerator when doors are opened) | Too frequent or too long door openings. | |
| Interior light does not work | No power at outlet. | <ul style="list-style-type: none"> • Replace fuse or reset the breaker. |
| | Light bulb burned out. | <ul style="list-style-type: none"> • See <i>Replacing the light bulb</i>. |

GE Service Protection Plus™

GE, a name recognized worldwide for quality and dependability, offers you Service Protection Plus™—comprehensive protection on all your appliances—**No Matter What Brand!**

Benefits Include:

- Backed by GE
- All brands covered
- Unlimited service calls
- All parts and labor costs included
- No out-of-pocket expenses
- No hidden deductibles
- One 800 number to call

***We'll Cover Any Appliance.
Anywhere. Anytime.****

You will be completely satisfied with our service protection or you may request your money back on the remaining value of your contract. No questions asked. It's that simple.

Protect your refrigerator, dishwasher, washer and dryer, range, TV, VCR and much more—**any brand!** Plus there's no extra charge for emergency service and low monthly financing is available. Even icemaker coverage and food spoilage protection is offered. You can rest easy, knowing that all your valuable household products are protected against expensive repairs.

Place your confidence in GE and call us in the U.S. toll-free at **800.626.2224** for more information.

*All brands covered, up to 20 years old, in the continental U.S.



Please place in envelope and mail to:

General Electric Company
Warranty Registration Department
P.O. Box 32150
Louisville, KY 40232-2150

Consumer Product Ownership Registration

Dear Customer:

Thank you for purchasing our product and thank you for placing your confidence in us.

We are proud to have you as a customer!

Follow these three steps to protect your new appliance investment:

1

Complete and mail your Consumer Product Ownership Registration today. Have the peace of mind of knowing we can contact you in the unlikely event of a safety modification.

2

After mailing the registration below, store this document in a safe place. It contains information you will need should you require service. Our service number is 800.GE.CARES (800.432.2737).

3

Read your Owner's Manual carefully. It will help you operate your new appliance properly.

Model Number

Serial Number

Important: If you did not get a registration card with your product, detach and return the form below to ensure that your product is registered, or register online at www.GEAppliances.com.

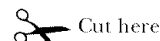

Consumer Product Ownership Registration



Model Number

Serial Number

Mr. Ms. Mrs. Miss

First Name

Last Name

Street Address

Apt. #

E-mail Address*

City

State

Zip Code

Date Placed In Use
Month

Day

Year

Phone Number --

* Please provide your e-mail address to receive, via e-mail, discounts, special offers and other important communications from GE Appliances (GEA).

Check here if you do not want to receive communications from GEA's carefully selected partners.



GE Appliances

GE Consumer Products
General Electric Company
Louisville, Kentucky
www.GEAppliances.com

Refrigerator Warranty.

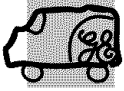

All warranty service provided by our Factory Service Centers, or an authorized Customer Care® technician. To schedule service, on-line, 24 hours a day, visit us at www.GEAppliances.com, or call 800.GE.CARES.

Staple your receipt here.
Proof of the original purchase date is needed to obtain service under the warranty.

For The Period Of: GE Will Replace:

One Year

From the date of the original purchase

Any part of the refrigerator which fails due to a defect in materials or workmanship. During this **full one-year warranty**, GE will also provide, **free of charge**, all labor and in-home service to replace the defective part.

Five Years

From the date of the original purchase

Any part of the sealed refrigerating system (the compressor, condenser, evaporator and all connecting tubing) which fails due to a defect in materials or workmanship. During this **additional four-year warranty**, GE will also provide, **free of charge**, all labor and in-home service to replace the defective part.

What GE Will Not Cover:

- Service trips to your home to teach you how to use the product.
- Improper installation.
- Failure of the product if it is abused, misused, or used for other than the intended purpose or used commercially.
- Loss of food due to spoilage.
- Replacement of house fuses or resetting of circuit breakers.
- Damage to the product caused by accident, fire, floods or acts of God.
- Incidental or consequential damage caused by possible defects with this appliance.

This warranty is extended to the original purchaser and any succeeding owner for products purchased for home use within the USA. In Alaska, the warranty excludes the cost of shipping or service calls to your home.

Some states do not allow the exclusion or limitation of incidental or consequential damages. This warranty gives you specific legal rights, and you may also have other rights which vary from state to state. To know what your legal rights are, consult your local or state consumer affairs office or your state's Attorney General.

Warrantor: General Electric Company, Louisville, KY 40225

Safety Instructions

Operating Instructions

Installation Instructions

Troubleshooting Tips

Consumer Support

Consumer Support



GE Appliances Website

www.GEAppliances.com

Have a question or need assistance with your appliance? Try the GE Appliances Website 24 hours a day, any day of the year! For greater convenience and faster service, you can now download Owner's Manuals, order parts, catalogs, or even schedule service on-line. You can also "Ask Our Team of Experts™" your questions, and so much more...

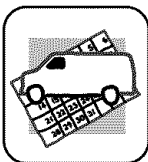

Schedule Service

www.GEAppliances.com

Expert GE repair service is only one step away from your door. Get on-line and schedule your service at your convenience 24 hours any day of the year! Or call 800.GE.CARES (800.432.2737) during normal business hours.

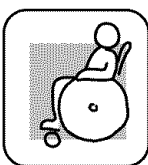

Real Life Design Studio

www.GEAppliances.com

GE supports the Universal Design concept—products, services and environments that can be used by people of all ages, sizes and capabilities. We recognize the need to design for a wide range of physical and mental abilities and impairments. For details of GE's Universal Design applications, including kitchen design ideas for people with disabilities, check out our Website today. For the hearing impaired, please call 800.TDD.GEAC (800.833.4322).



Extended Warranties

www.GEAppliances.com

Purchase a GE extended warranty and learn about special discounts that are available while your warranty is still in effect. You can purchase it on-line anytime, or call 800.626.2224 during normal business hours. GE Consumer Home Services will still be there after your warranty expires.

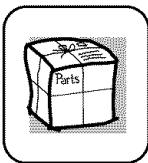

Parts and Accessories

www.GEAppliances.com

Individuals qualified to service their own appliances can have parts or accessories sent directly to their homes (VISA, MasterCard and Discover cards are accepted). Order on-line today, 24 hours every day or by phone at 800.626.2002 during normal business hours.

Instructions contained in this manual cover procedures to be performed by any user. Other servicing generally should be referred to qualified service personnel. Caution must be exercised, since improper servicing may cause unsafe operation.



Contact Us

www.GEAppliances.com

If you are not satisfied with the service you receive from GE, contact us on our Website with all the details including your phone number, or write to: General Manager, Customer Relations
GE Appliances, Appliance Park
Louisville, KY 40225



Register Your Appliance

www.GEAppliances.com

Register your new appliance on-line—at your convenience! Timely product registration will allow for enhanced communication and prompt service under the terms of your warranty, should the need arise. You may also mail in the pre-printed registration card included in the packing material.