

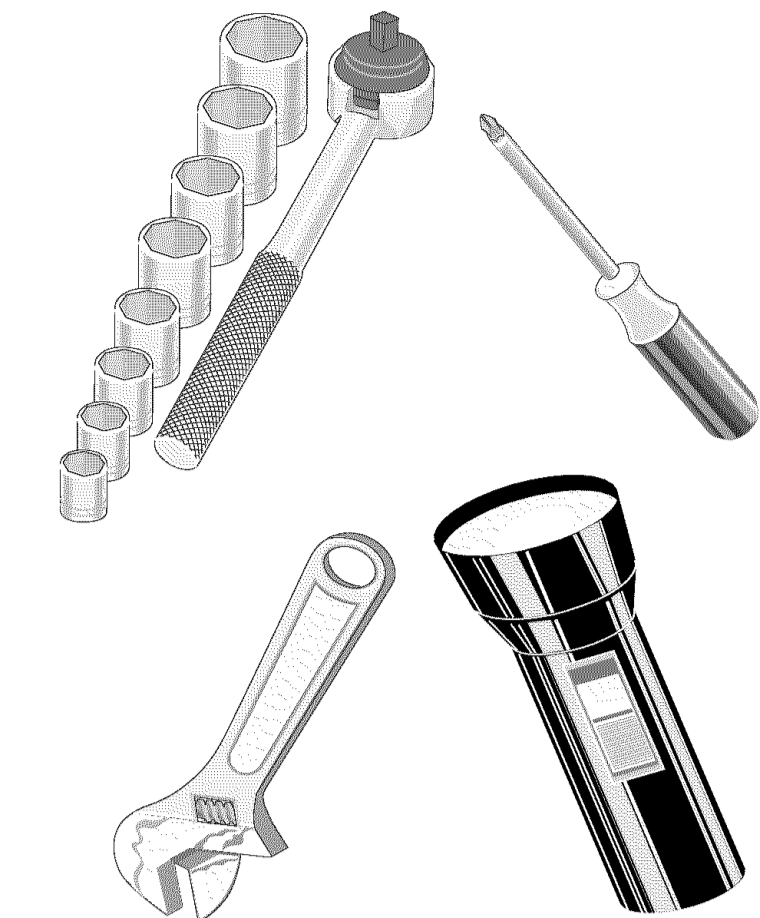

# Dishwasher Installation Instructions



**INSTALLER:** Leave Installation Instructions with owner.  
**OWNER:** Read your dishwasher Use and Care Guide. It contains important safety information for operating this appliance. It also has many suggestions for getting the best results from your dishwasher.

Printed in U.S.A. 154416001 (11/01)  
Sears, Roebuck and Co., Hoffman Estates, IL 60179 U.S.A.

## Before You Begin

Read all instructions before installing dishwasher. For your safety, please read and observe all safety instructions. This guide will help you anticipate drain, water, and electrical connections, and help you select the best location for the dishwasher.

### WARNING

**Tip Over Hazard**  
Do not use dishwasher until completely installed.  
Do not push down on open door.  
Failure to follow this warning can result in serious injury.

## Installation Tips 1

### Tools and Materials Needed for Installation

- Drill, Electric
- Driver, Socket 3/16", 1/4", 5/16"
- Flaring Tool / Tube Cutter (for copper tubing)
- Flashlight
- Gloves
- Level
- Pipe Joint Compound (for iron pipe plumbing) or Pipe Thread Tape (for sealing threads)
- Pliers
- Safety Glasses
- Saw, Keyhole or 1/4", 1 1/2" to 2" Hole Cutters
- Screw Drivers, Slotted and #2 Phillips (magnetic tip preferred)
- Tape, Electrical or Duct
- Tape, Measuring
- Wire Stripper or Utility Knife
- Wrench, Hex-end
- Wrenches, 2 Adjustable (for copper tubing) or 2 Pipe wrenches (for iron pipe plumbing)

## Leveling Dishwasher within Cabinets 5

1. Measure height of cabinet opening from underside of countertop to floor. Check chart for height opening and suggested adjustment.

Height of Cabinet Opening	Number of Turns to Adjust Levelers
34" (86.4cm)	0
34 1/8" (86.7cm)	2
34 1/4" (87.2cm)	6
34 1/2" (87.6cm)	9

For additional height add shims under levelers.

2. Move dishwasher to front of installation area.
3. Loosen the front and rear leveling legs by turning counterclockwise. Refer to chart for number of turns. See Figure 8. Front levelers should allow 1/4" below underside of countertop.

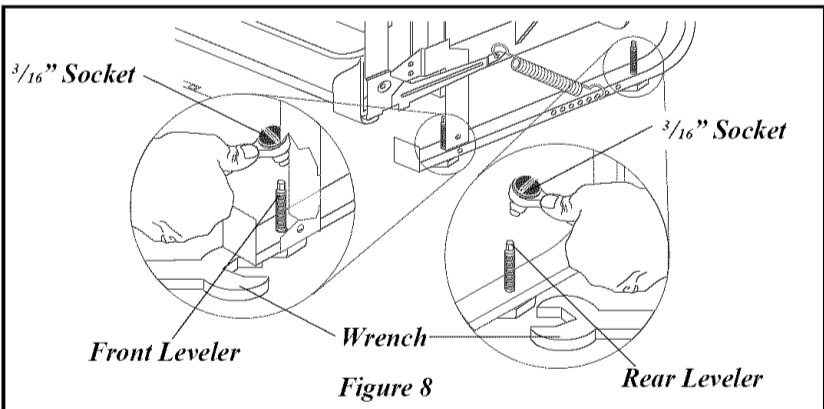

4. If levelers have to be removed, make sure floor is free of obstructions.
5. Place dishwasher inside cabinet area so that it is centered in opening. Use caution when moving dishwasher to prevent damage to dishwasher, floor, and cabinets.
6. Check that dishwasher is level from side to side by placing a level against the top front section of the tub. See Figure 9a.

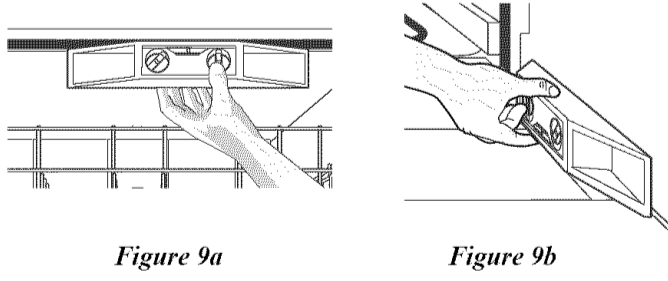

7. Check that dishwasher is level from front to back by placing level on side of opened door. See Figure 9b.
8. Adjust levelers up or down until dishwasher is level.

### Helpful tip for built-up floors:

Measure height of opening from underside of countertop to built-up floor. If the height is at least 33-3/4" (84.5 cm), the dishwasher will fit into the opening without modification to the countertop or flooring.

Put front and rear levelers all the way up. If the opening is at least 33-3/4" (84.5 cm), the countertop mounting brackets may need to be removed to avoid damage to the top of the dishwasher console. If so, follow directions in Step 9 for floor anchoring when ready to secure unit.

## Finishing the Drain Connection 6

### WARNING

**Electric Shock Hazard**  
Plumbing material and drain hose must not come in contact with wiring or electrical components.  
Failure to follow this warning could result in personal injury from exposed wiring.

1. Pull out unit and check to see if drain hose is correctly attached to the drain pump assembly. If drain hose is **not attached** to drain pump, follow the instruction sheet (included with drain hose) on how to correctly install the drain hose to the drain pump assembly.
2. Move unit back in place while routing drain hose through access hole. Use caution to prevent damage to the dishwasher, floor and cabinets. **IMPORTANT:** Make sure there are no sharp bends or kinks that might restrict drain flow.
3. Secure drain hose to sink drain, disposer, or separate trap with a clamp. **IMPORTANT:** Be careful not to overtighten clamp or you may damage end of hose. Do not connect hose to horizontal pipe between sink drain and disposer.
4. Be sure unit does not rest on drain hose. It should be free of electrical components and door springs. Do not cut corrugated drain hose. Pull excess through cabinet and place under sink. Make sure hose does not come in contact with any sharp edges. See Figure 10.

## Parts you'll need\*

- Drain Hose Clamp, 1 1/2" Diameter (Included)
- Elbow, 90° with a 3/8" National Pipe Thread (not included)
- Strain Relief Bushing (not included)
- Wire Nuts, two (2) for 12-14 gauge wire (not included)

- If required:**
- "Y" Branch Tailpiece and Connector Kit (See Step 4)
  - Air Gap Kit (See Step 4)
  - Fasteners for floor anchoring (See Step 9)
- Available at:**
- Plumbing Supply Store
  - Plumbing Supply Store
  - Hardware Store

### WARNING

**Electric Shock Hazard**  
Disconnect electrical power at the fuse box or circuit breaker box before beginning installation. Failure to follow this warning could result in death or serious injury.

- Examine dishwasher and locate connections. See Step 4.
- Locate dishwasher where there is easy access to drain, water, and electrical lines. The best location is on either side of the kitchen sink for access to existing plumbing and ease in loading dishes. See Step 4.
- Electrical, water, and drain connections are not the same for all age, brands, or models of dishwashers. Check the location and length of home utilities. See Step 4.
- A 15-20 amp, grounded, 120 volt AC only, electrical supply is required. See Steps 4 and 8.
- If dishwasher drain hose will be connected to a food disposer for the first time, knock out plug located inside disposer inlet. See Steps 4 and 6.
- Kinked water or drain hoses can cause problems. See Step 6.
- Dishwashers need to be connected to a hot water supply with enough water pressure to insure an adequate fill. See Steps 4 and 7.
- Each home installation differs. You will need additional parts listed above to complete your installation. See Steps 4 and 7.
- Flush water line prior to making the final connection to prevent clogging of dishwasher's filter screen. See Step 7.
- The dishwasher will look, sound, and perform best when properly leveled. See Step 5. (NOTE: If levelers are removed during installation, make sure the floor is flat and free of any obstruction.)
- Anchor the dishwasher to countertop. See Step 9.

## Installation Preparation 2

1. Remove two (2) screws at front of the kickplate assembly using a #2 Phillips screw driver.
2. Tilt and pull forward to remove. (Figure 1).

**NOTE:** It is not necessary to remove the outer door for installation. However, you might find it more convenient to do so. You can find directions for removing door in Step 10.

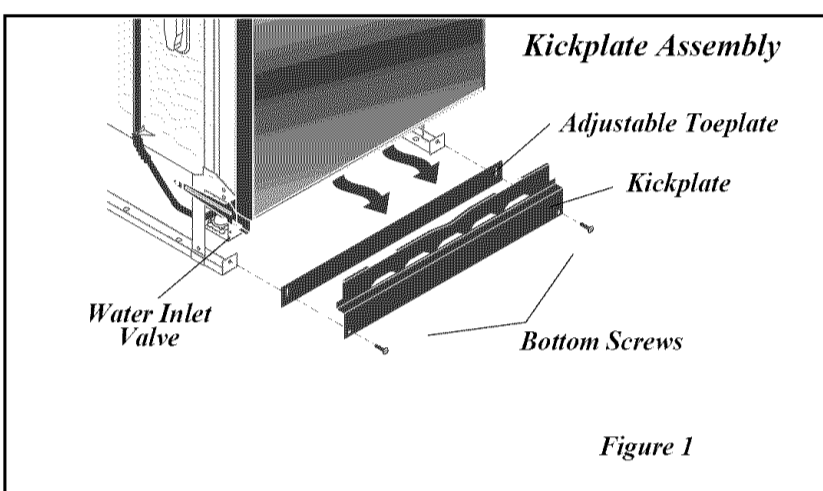

3. Locate water inlet valve behind kickplate on bottom left underside of unit. The valve has a 1/2" NPT female fitting.
4. Wrap 90° elbow (not included) with pipe thread tape (or apply joint compound) and thread it into water inlet valve.
5. Tighten elbow with a wrench, leaving elbow pointing toward rear of unit. To prevent bending of bracket or breaking of valve, avoid overtightening.

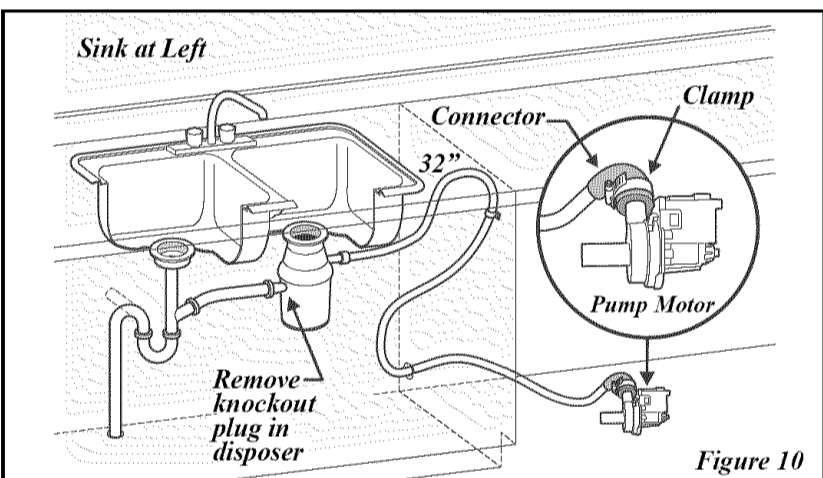

The drain hose loop must be at least 32" high from the floor to insure proper drainage.

## Finishing the Water Connection 7

### CAUTION

**Property Damage**  
Do not solder within 6" of the water inlet valve. Damage to the plastic parts in the valve may occur.  
Use care that no sealer, dirt, or other objects enter the valve. Damage to the filter screen may occur.  
Be sure the dishwasher is placed where the water inlet valve will be kept from freezing. If the valve freezes, it may rupture and flooding may occur.

1. Flush water line before connecting it to water inlet valve to prevent early clogging of filter screen. Place a bunched towel over end of line to prevent splashing. Open valve for a few seconds and let water drain into a pan. Turn off water supply at shut-off valve.

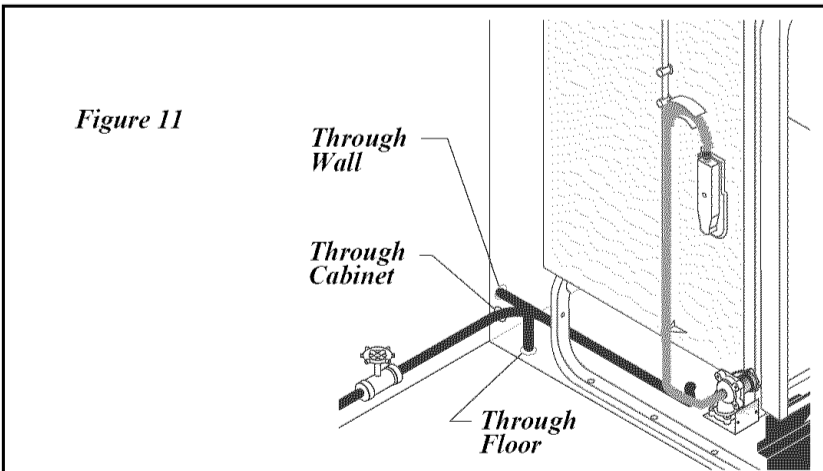

2. Route water line to water inlet valve as shown in Figure 11.
3. While firmly pulling water supply line into 90° elbow, tightly connect water supply to water inlet valve. Supply line must be free of kinks, scales, chips, and lubricants.
4. Turn on water supply and check for leaks.
5. If water inlet valve clogs, make sure water supply is off. Remove four (4) screws at inlet end of valve and clean filter screen.

## Finishing the Electrical Connection 8

### WARNING

**Electric Shock Hazard**  
Make sure electrical power has been disconnected at fuse box or circuit breaker box.  
The dishwasher must be connected to a grounded metal, permanent wiring system. The equipment-grounding conductor must be run with the circuit conductors and connected to the appliance's equipment grounding terminal or lead. It is the consumer's responsibility to contact a qualified installer to make sure the electrical installation conforms with the National Electrical Code and local codes and ordinances.  
Do not connect the dishwasher to the power supply until the appliance is permanently grounded.  
All wiring connections must be enclosed in the junction box. This unit has copper lead wires.  
Joining aluminum building wire to stranded copper wire should be done by a qualified electrician using materials recognized by UL and local codes.  
Do not use an extension cord. Such use can result in fire, electrical shock, or other personal injury.  
Failure to follow these instructions could result in death or serious injury.

## Roughing In 3

### WARNING

**Electric Shock Hazard**  
Observe all local codes and ordinances for electrical and plumbing connections. All electrical and plumbing work should be performed by qualified persons. Failure to follow this warning could result in death or serious injury.

1. Make sure your location has the right drain, water, and electrical outlets to make the connections. Do not install unit under a cooktop range. Damage to plastic tub will occur.

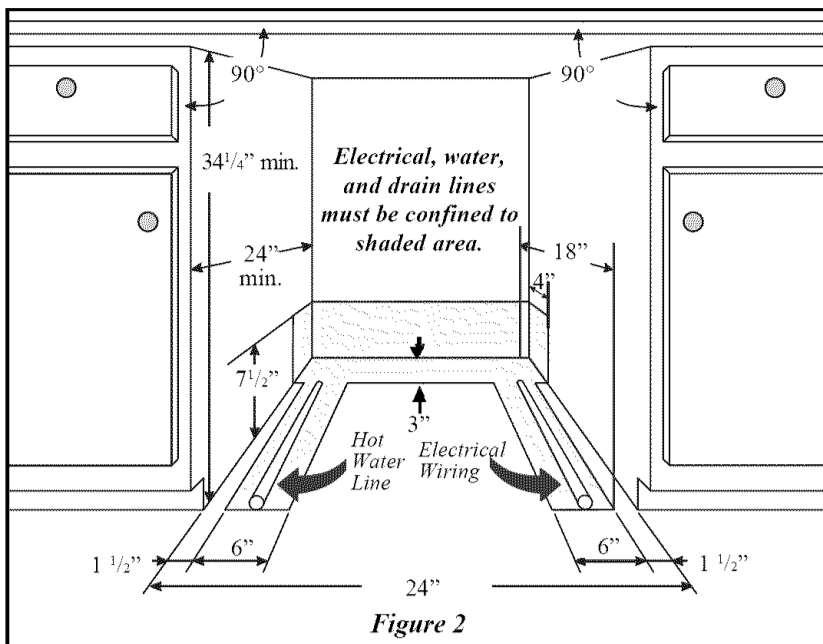

**IMPORTANT:** For proper operation and appearance of unit, cabinet opening should have dimensions as shown in Figure 2. If unit is to be placed in a corner, there must be at least a 2-inch side clearance to open door.

2. Remove any carpet from area to provide motor clearance. Floor should be flat and free of any obstruction.

**IMPORTANT:** Drain, water, and electrical lines should be roughed-in before going any further.

### WARNING

**Electric Shock Hazard**  
Electrical, water, and drain lines must be confined to shaded areas in Figure 2.  
Electric conductors, water, and drain could be damaged.  
Failure to follow these instructions could result in fire or electric shock.

**NOTE:** If dishwasher is installed at end of a cabinet line, sides and back must be fully enclosed.

## Connections For Electrical, Water, and Drain 4

**IMPORTANT:** Do not cross drain, water, and electrical lines in front of dishwasher motor or frame.

### Locating the Connections

1. Review dimensions in Figure 3 to locate dishwasher's drain, water, and electrical connections.
2. All connections must be made in shaded area in Figure 2.

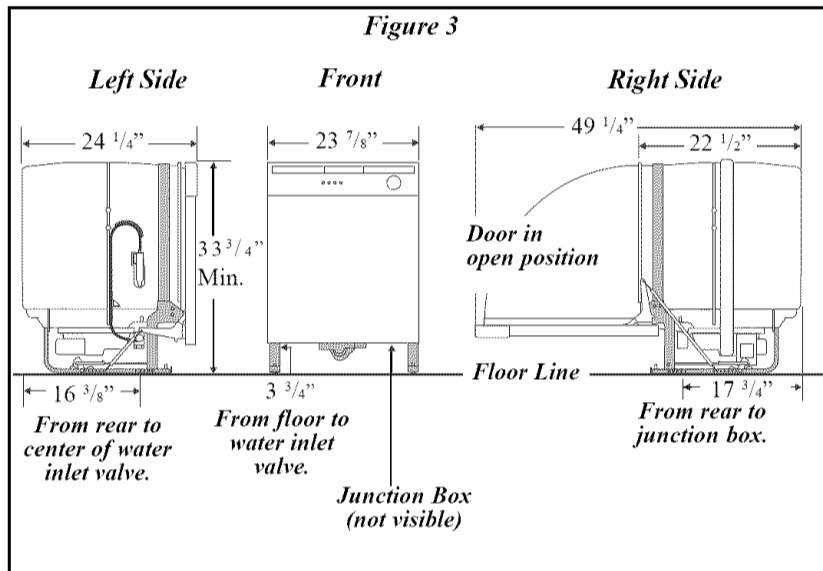

## Electrical Supply

1. Remove junction box cover and pull house wiring into junction box. See Figures 12 and 13.
2. Use a UL listed strain-relief bushing, not included, at box to stabilize wiring.

**IMPORTANT:** Be sure electrical cable is not routed behind dishwasher's motor.

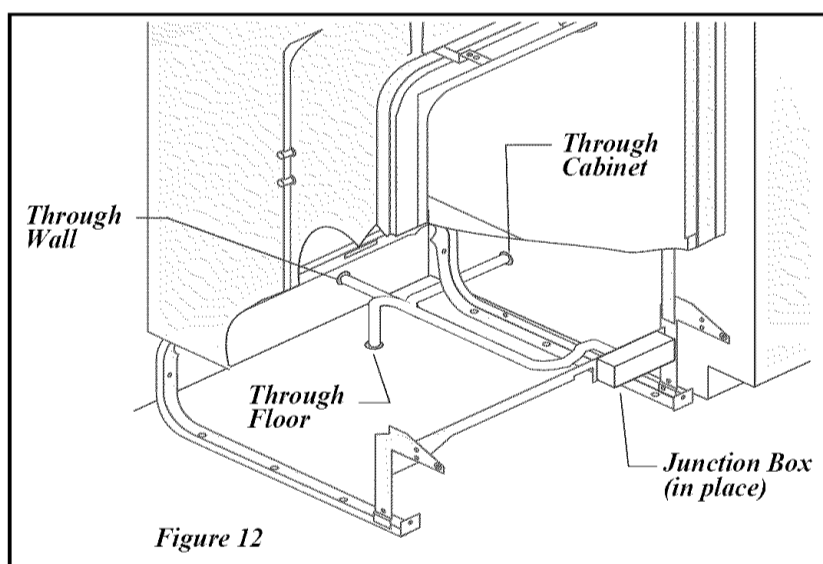

3. Inside junction box, attach ground wire under head of grounding screw and tighten. See Figure 13.
4. Connect incoming black lead to dishwasher's black lead and incoming white lead to dishwasher's white lead with wire nuts or other suitable connectors, not included. Wire nuts should be tight.
5. Replace junction box cover. See Figure 13.

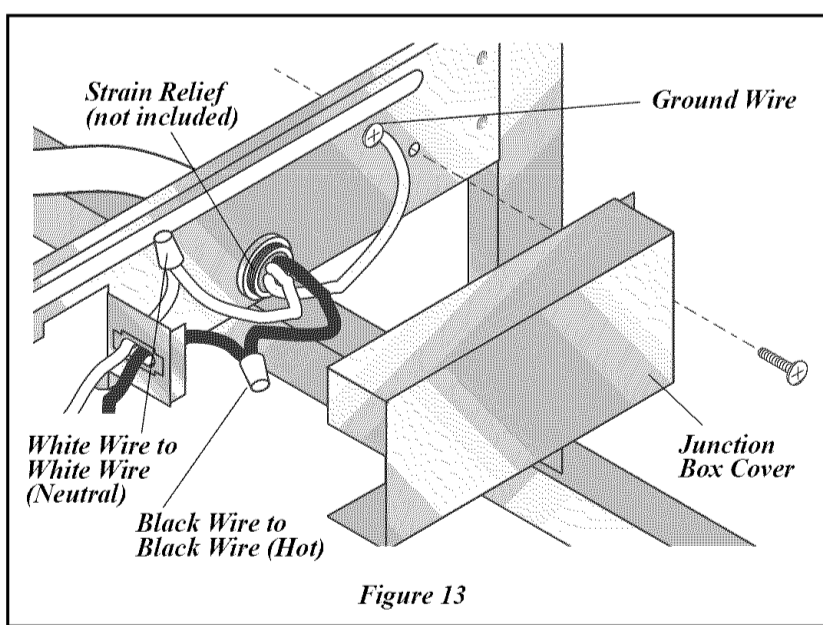

## Securing the Dishwasher 9

The dishwasher must be secured to keep it from tilting when door is opened. Choose one of the methods described below to secure unit.

### Countertop Anchoring

1. Adjust levelers (see Step 5) so mounting brackets touch underside of countertop. **IMPORTANT:** Dishwasher must rest on floor—do not hang from countertop. See Figure 14.
2. Screw mounting brackets firmly to countertop using screws provided in literature packet.
3. Open and close dishwasher door slowly. If door hits mounting bracket screw heads, adjust front levelers.

**Note:** Open and close door to make sure it does not hit surrounding cabinets or countertop.

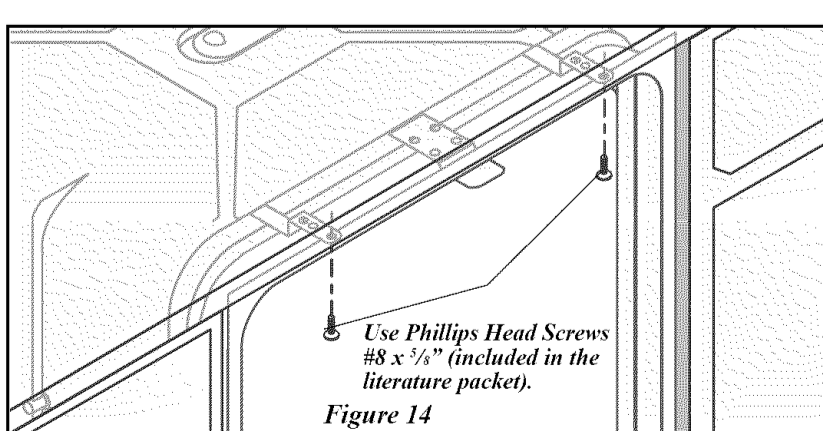

**IMPORTANT:** Disconnect power before starting installation.

## Electrical

1. The dishwasher operates on a 120 volt, 60 Hz electrical supply. Provide a separate circuit with a fuse or circuit breaker rated for at least 15 amps (20 amps if connected with disposer) but not more than 20 amps.
2. Note the locations of electrical supply and dishwasher's electrical junction box on right underside of unit behind kickplate assembly. See Figure 3.
3. Cut access hole in shaded area shown in Figure 2.
4. Pull electrical cable through hole into installation area.

## Water

1. Determine where you will connect to hot water supply. Review Figure 3 and note the location of water inlet valve.

### CAUTION

**Property Damage**  
Do not use the furnished drain hose or a rubber garden hose for the water supply line. Either of these hoses can burst. Flooding may occur and cause property damage.

2. Be sure water inlet valve is protected from freezing. If valve freezes and ruptures, flooding may occur.
3. Determine amount of tubing needed to connect hot water supply to the unit's water inlet valve. Copper tubing must have a minimum 3/8" OD. High-pressure and high-temperature rated plastic tubing with a minimum inner diameter of 1/4" may be used. A shut-off valve installed outside dishwasher cabinet is best. See Figure 4.

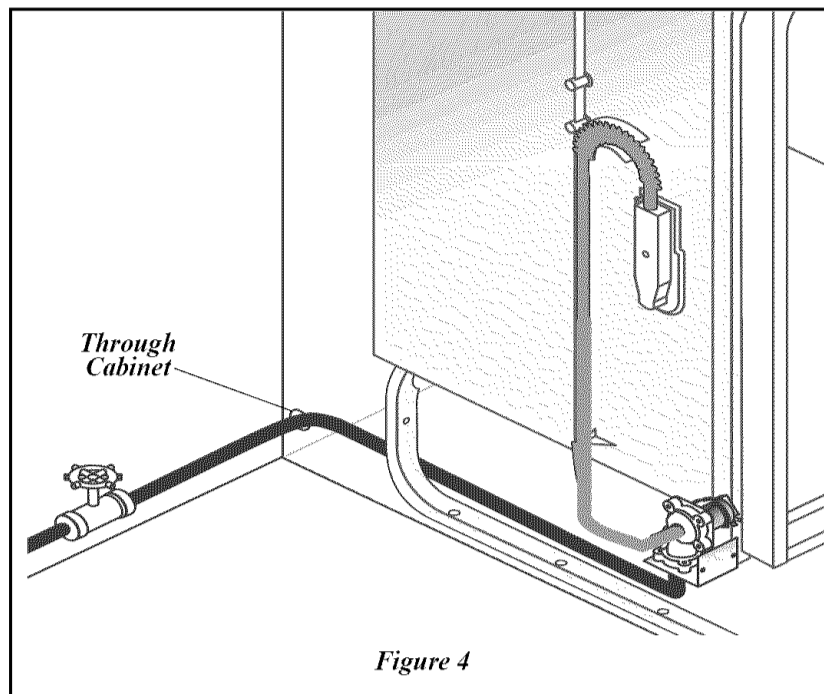

4. Cut water access hole in shaded area in Figure 2.
5. Route water supply line into installation area.

**IMPORTANT:** Incoming hot water temperature should be at least 120°F (49°C). Water pressure should be between 20-120 psi.

## Drain

1. Review Figures 5 and 6 to see the different ways to connect dishwasher to drain system. Choose method that best suits your need.

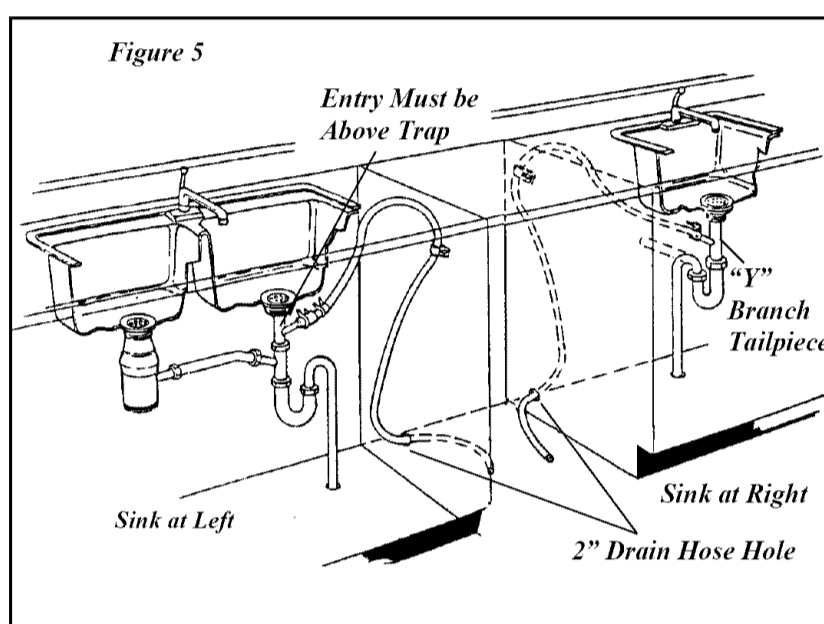

2. If you connect to a sink drain, entry will need to be above trap. A "Y" branch tailpiece and connector kit, not included, will make this method easier and includes all needed fittings and instructions. See Figure 5.

## Floor Anchoring

This procedure is difficult and should be used only if countertop mounting brackets cannot be used.

1. Screw 1/4" lag screws, not included, through holes provided in frame rail. See Figure 15.
2. Use expansion fasteners if floor is concrete.

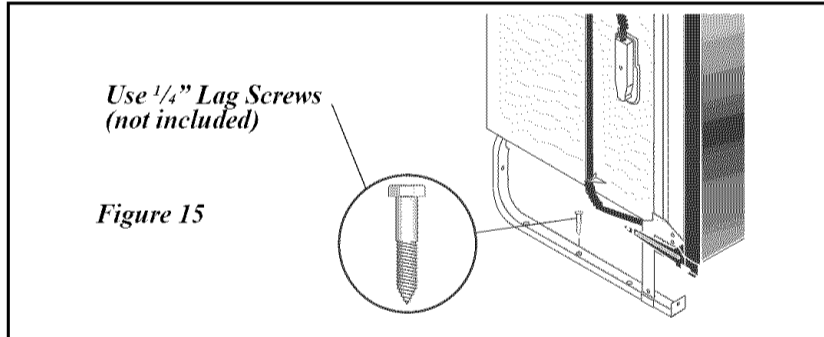

## Removing & Replacing Door 10

### WARNING

**Electric Shock Hazard**  
Disconnect electrical power at the fuse box or circuit breaker box before beginning installation. Failure to follow this warning could result in death or serious injury.

### CAUTION

**Cut Hazard**  
Metal color panels are sharp and should be handled with care. Wear gloves to protect hands. Failure to follow this warning may result in injury.

### To Remove and Replace Outer Door

1. Unlatch and open door. Using a Phillips head screw driver, remove two (2) screws from inner door. Save screws to reassemble. See Figure 16a.

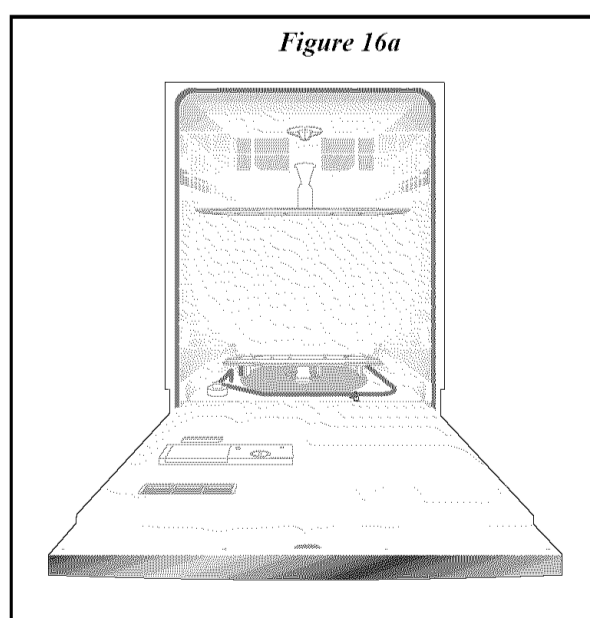

2. Close and latch door while holding both sides.
3. Place one hand on each side of door and pull down at top approximately 1/4". Pull entire door assembly toward you to remove. See Figure 16b.

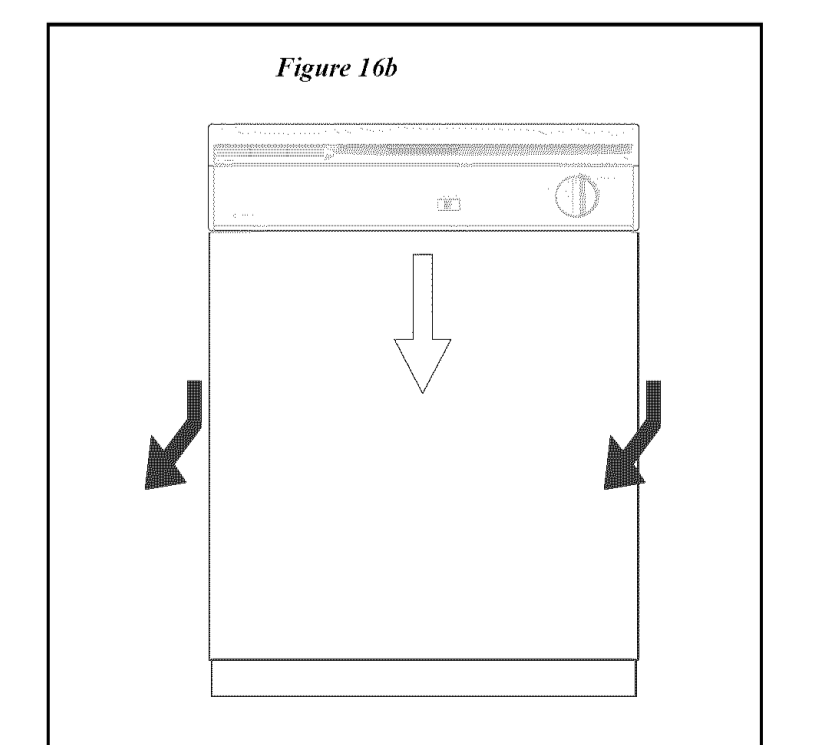

4. Place door where it will not get scratched or damaged while completing installation.

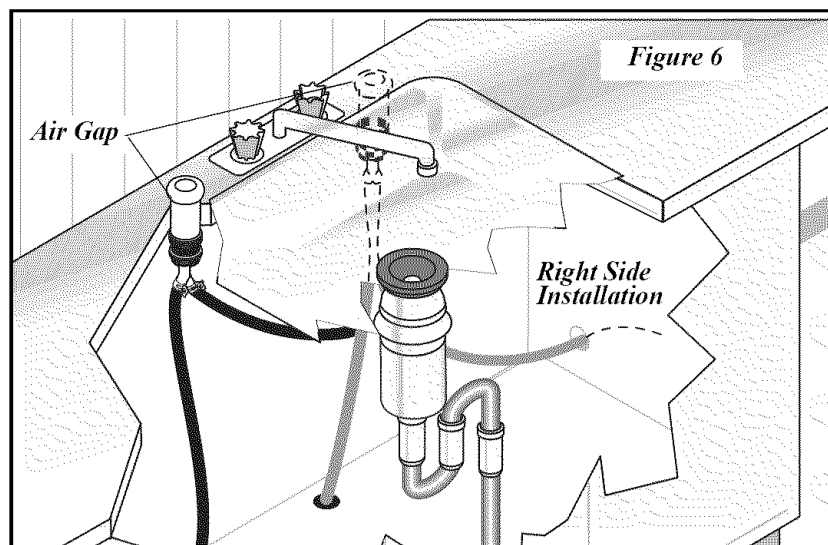

3. If you connect to a sink trap, local codes may require you to install an air gap kit, not included. The drain hose will be routed from dishwasher to air gap inlet as shown in Figure 6. An air gap kit is available from a plumbing supply store.
4. If you connect to a disposer, the large end of drain hose will fit. Figure 7(a). The knock out plug must be removed from inside disposer inlet before making the final fit to drain hose. See Figure 7(b).

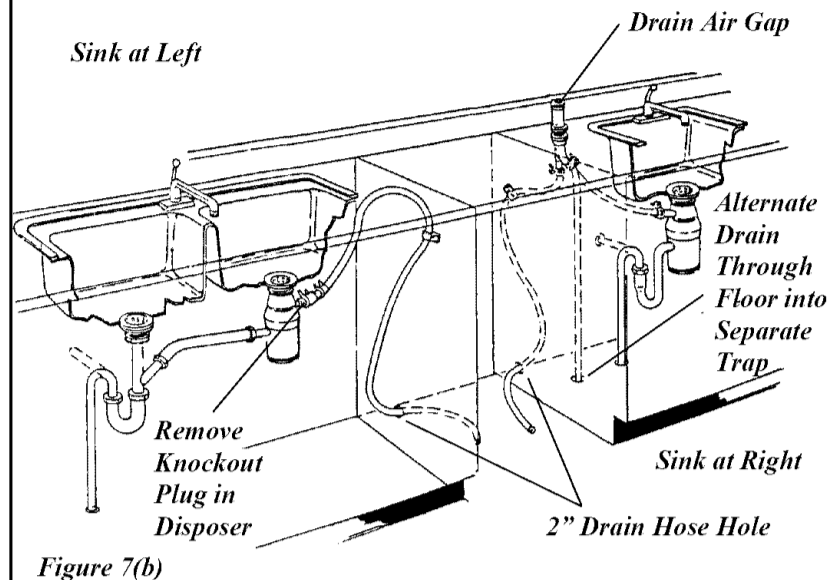
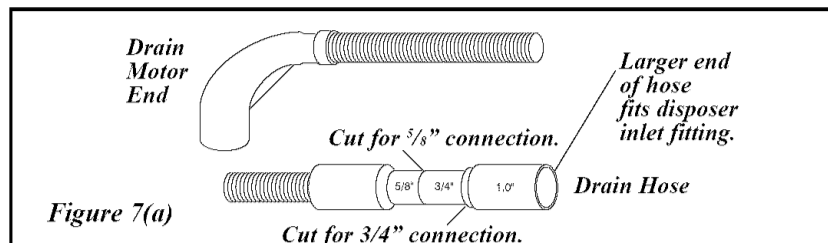

5. Before cutting drain hose access, check both sides of selected area to avoid interference. Cut a 2" diameter hole in shaded area shown in Figure 2.
6. If the cabinet wall is wood, sand edges of hole until smooth and rounded. If cabinet wall is metal, cover all sharp edges with electrical or duct tape to avoid cutting drain hose.

**IMPORTANT:** Incoming hot water temperature should be at least 120°F (49°C). Water pressure should be between 20-120 psi.

## Drain

1. Review Figures 5 and 6 to see the different ways to connect dishwasher to drain system. Choose method that best suits your need.

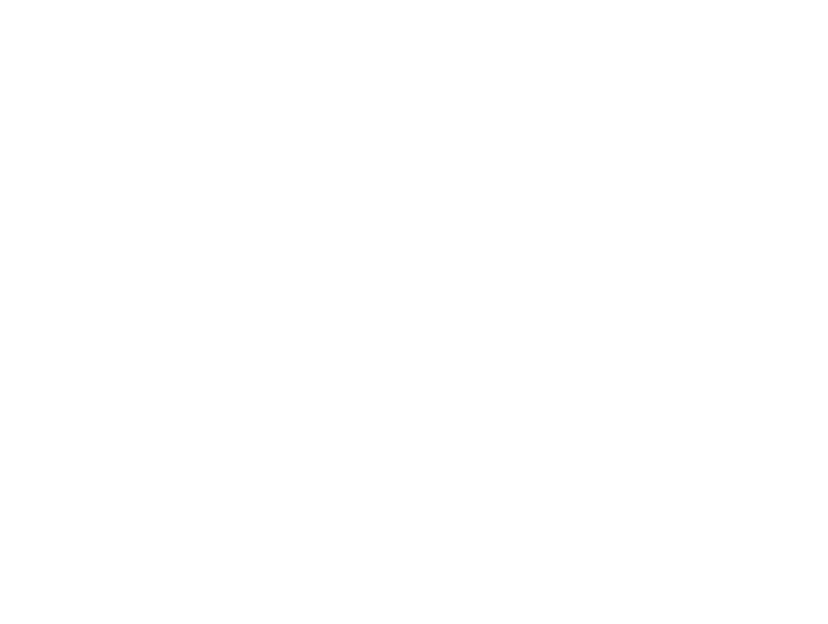

2. If you connect to a sink drain, entry will need to be above trap. A "Y" branch tailpiece and connector kit, not included, will make this method easier and includes all needed fittings and instructions. See Figure 5.