

Assembly Guide

HDTV DIGITAL RECEIVER

Panasonic

TU-DST52F

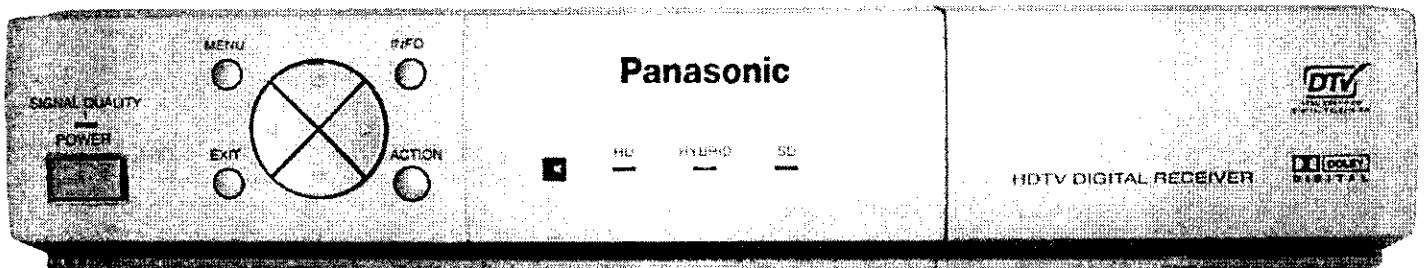

This Assembly Guide is issued as a service assembly-disassembly guide for the model listed above. Included in this manual are disassembly-assembly procedures, illustrated parts list, complete parts list and a parts list for reburishing purposes.

Panasonic

Copyright 2002 by Matsushita Electric Corporation of America. All rights reserved. Unauthorized copying and distribution is a violation of law.

Table of Contents

TOP COVER.....	3
Removal.....	3
Assembly	3
FRONT PANEL	4
Removal.....	4
Assembly	4
FRONT PANEL ASSY.....	5
Disassembly	5
A BOARD	6
P BOARD	7
FAN	7
BOTTOM CHASSIS	8
PACKING	9
Packing Box	9
Cushion Box	10
Complete Packing	11
Parts List for refurbished.....	12
Complete parts list.....	16

TOP COVER

The top cover is secured to the bottom chassis by 3 screws

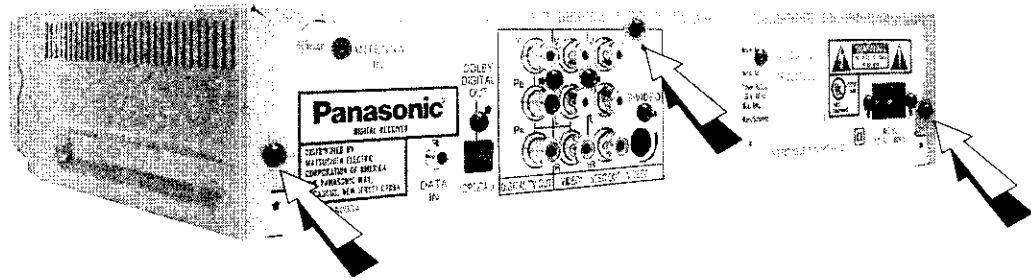

REMOVAL:

Remove the 3 screws from the back that secure the cover.
Slide the cover completely to the back of the set.

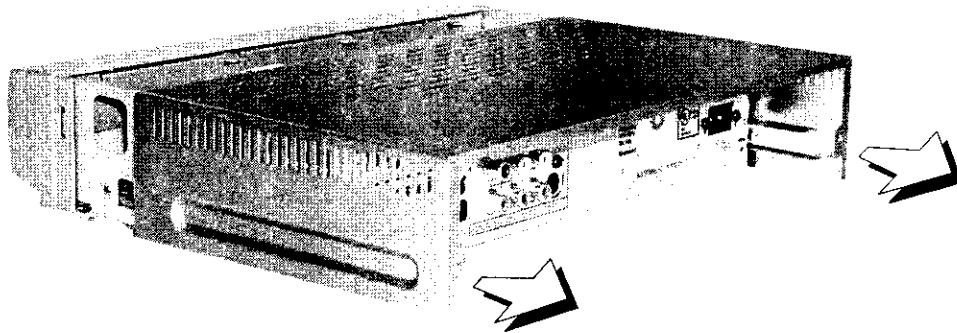

ASSEMBLY:

Slide the top cover all the way to the front of the set.
Confirm that the top cover tabs are correctly assembled into the bottom chassis as shown.

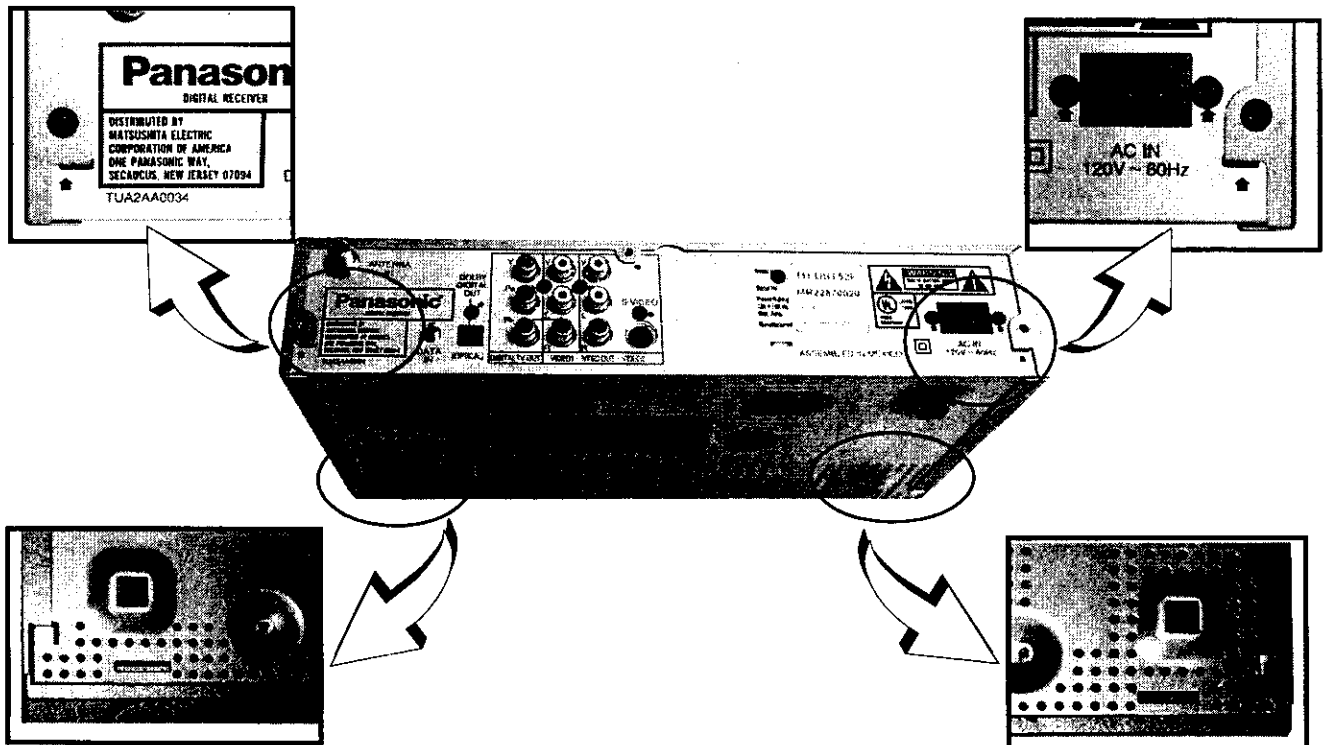

FRONT PANEL

The front panel is secured to the bottom chassis by the side tabs.

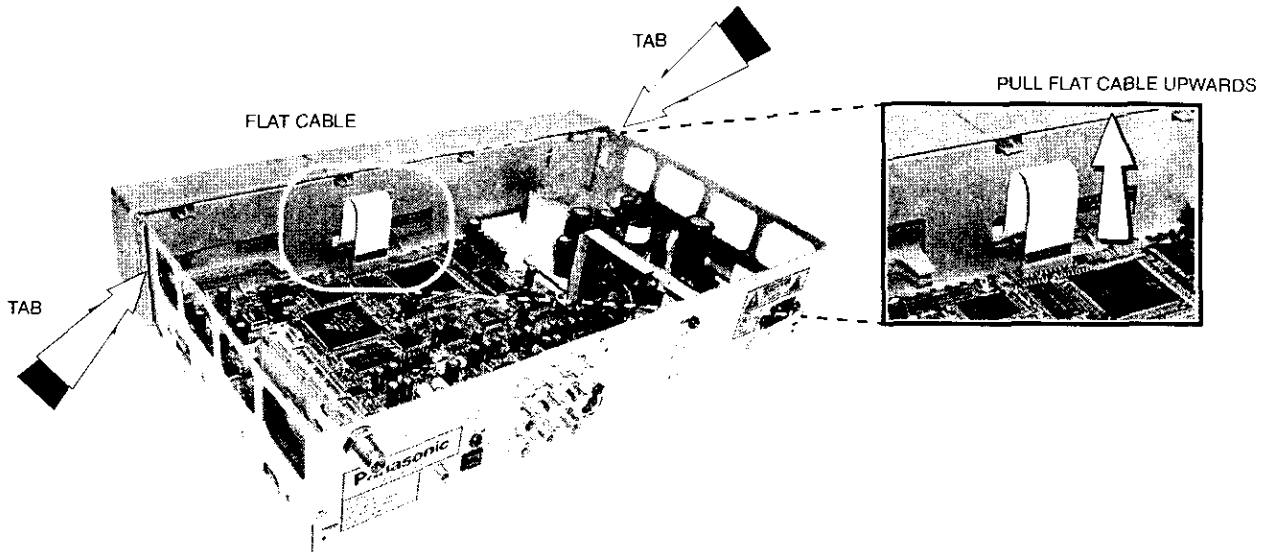

REMOVAL

Unplug the flat cable from the A-Board as shown above. Grab the cable from the center and pull carefully, do not pull the cable from the sides.
Push the left and right sides of the bottom chassis near the tabs, to release the front panel.

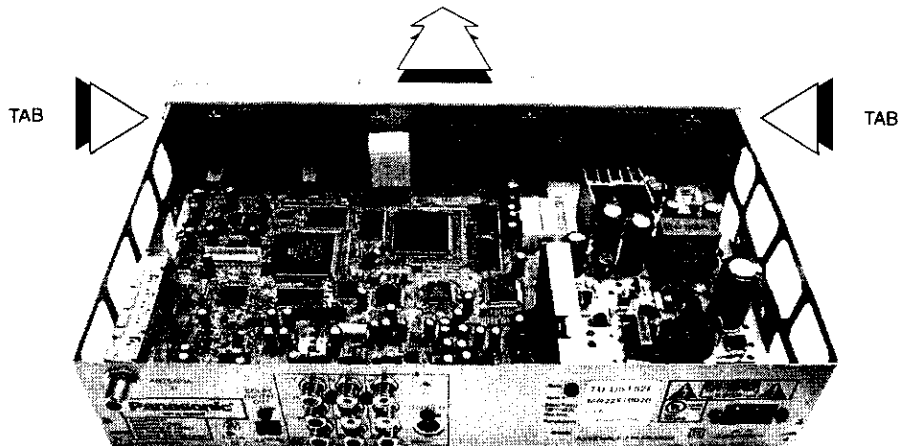

ASSEMBLY

Confirm that all the marks from the front panel match with the spaces in the bottom of the chassis and insert firmly until the panel is secured to the bottom chassis by the side tabs.

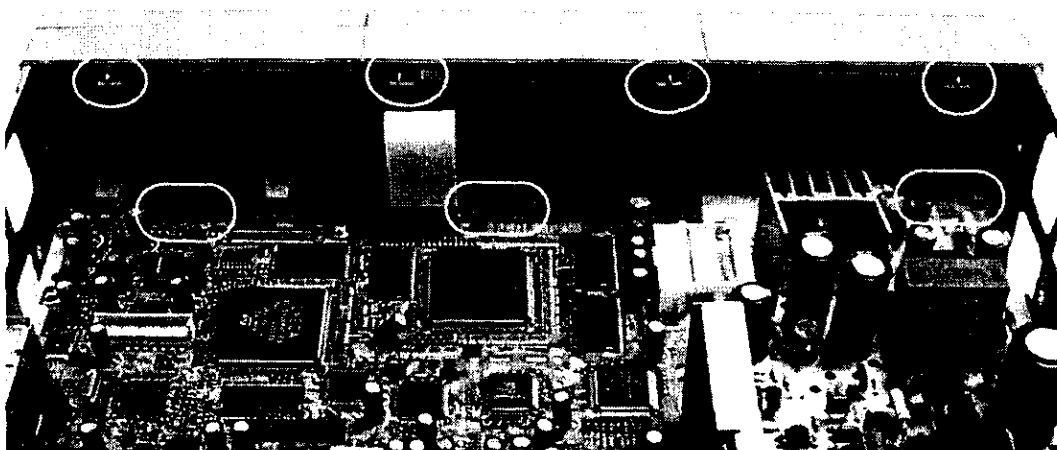

FRONT PANEL ASSEMBLY

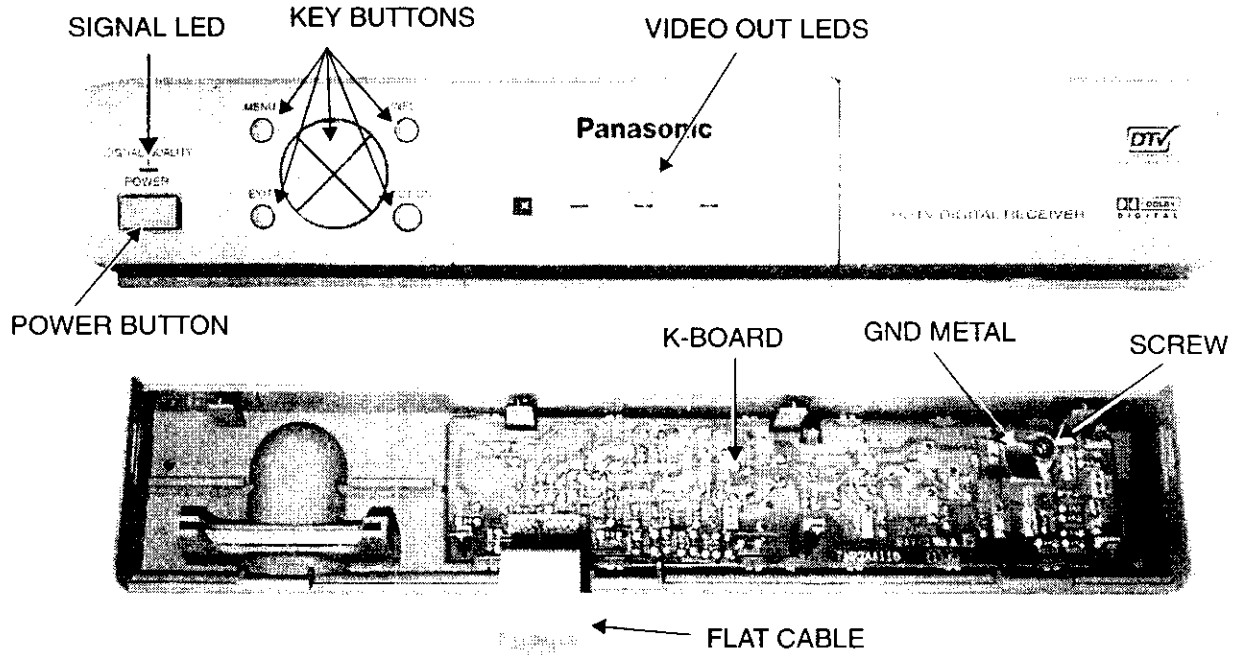

DISASSEMBLY

Remove the screw and the GND metal.
Open the locking tabs to release the K-Board from the panel.

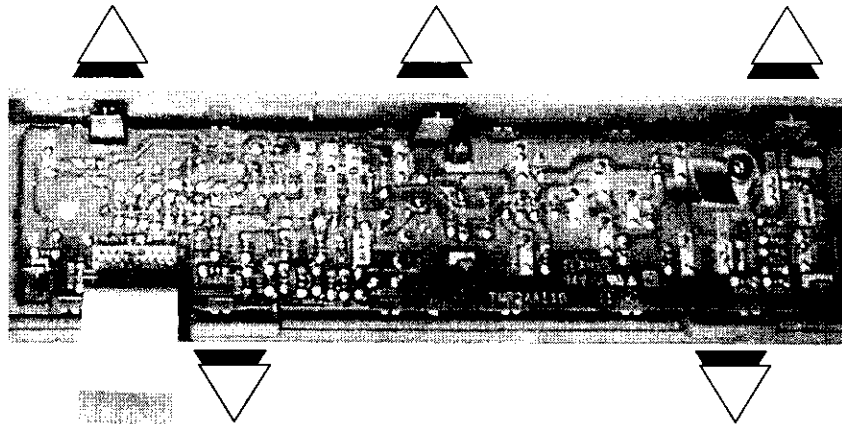

The IR guide and the SIGNAL LED panel are mounted into a plastic guide on the panel.

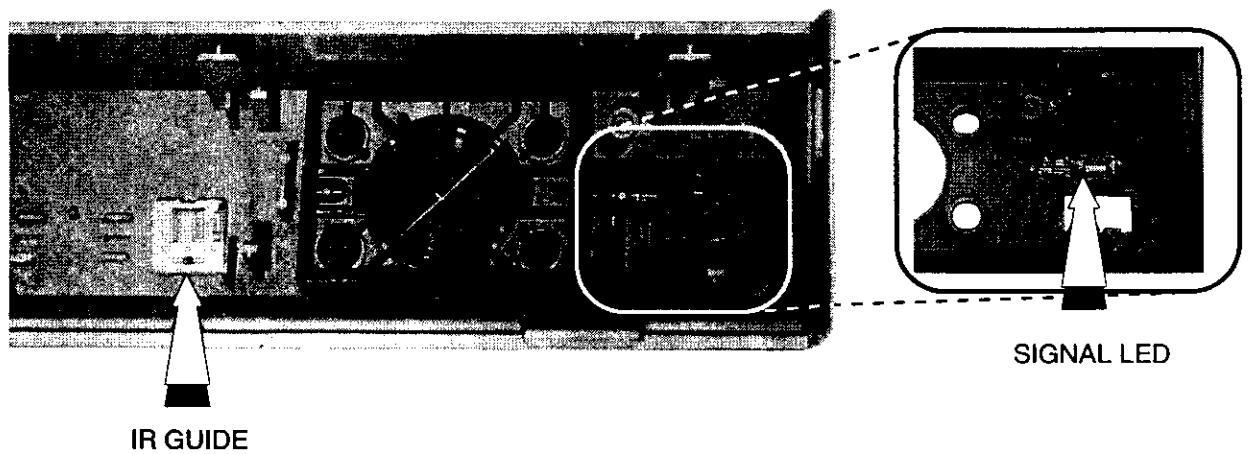

A-BOARD

A-Board is secured to bottom chassis by 4 screws, 5 screws on the back, washer and the Hex nut on the tuner jack.

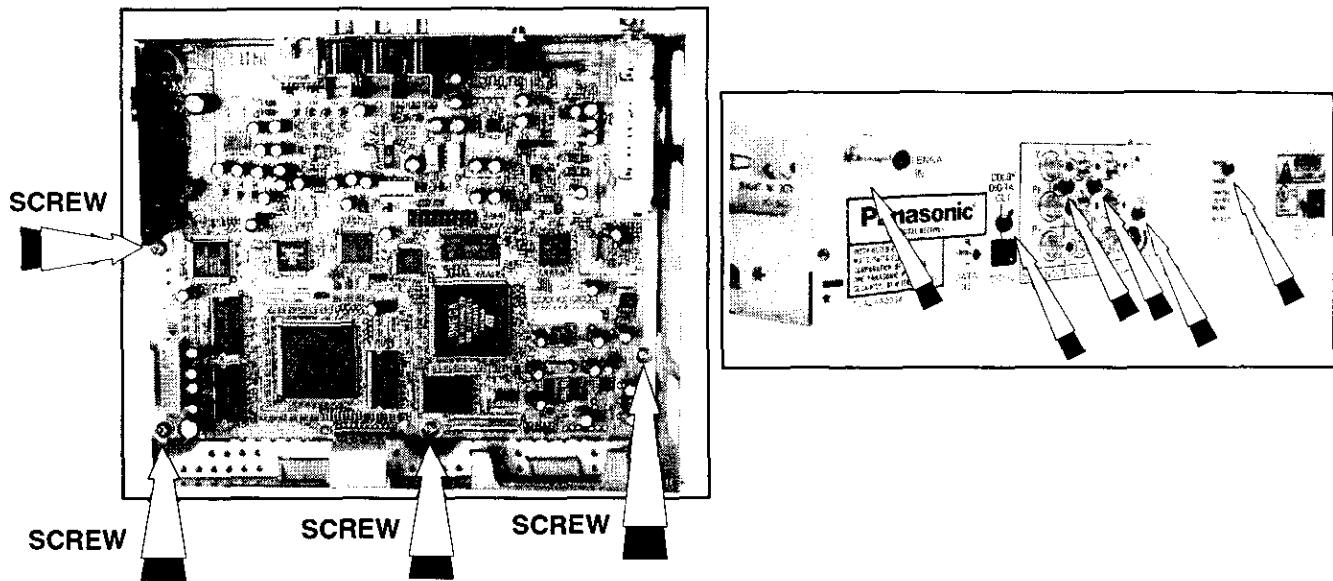

The connector has a tab, try to pull the connector from this tab with a flat screw.

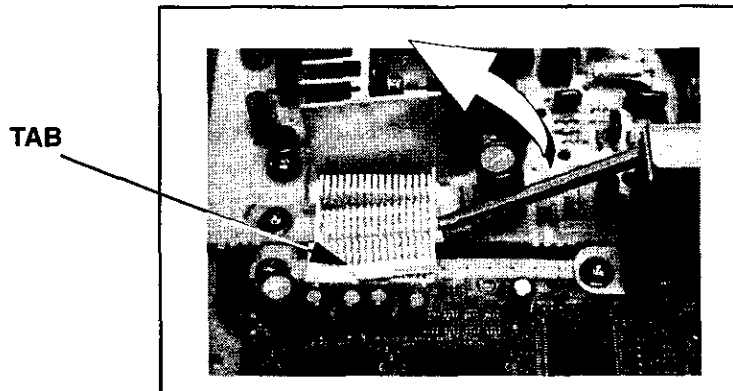

IMPORTANT:
Keep and re-use all hardware from original set. (Screws, nuts, washer).

P-BOARD

The P-Board is secured to the bottom chassis by 4 screws on the base and 2 screws on the A.C. connector.

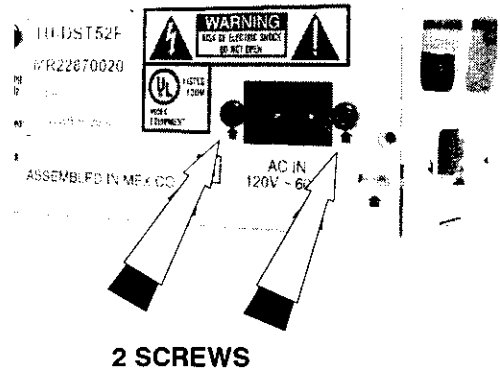
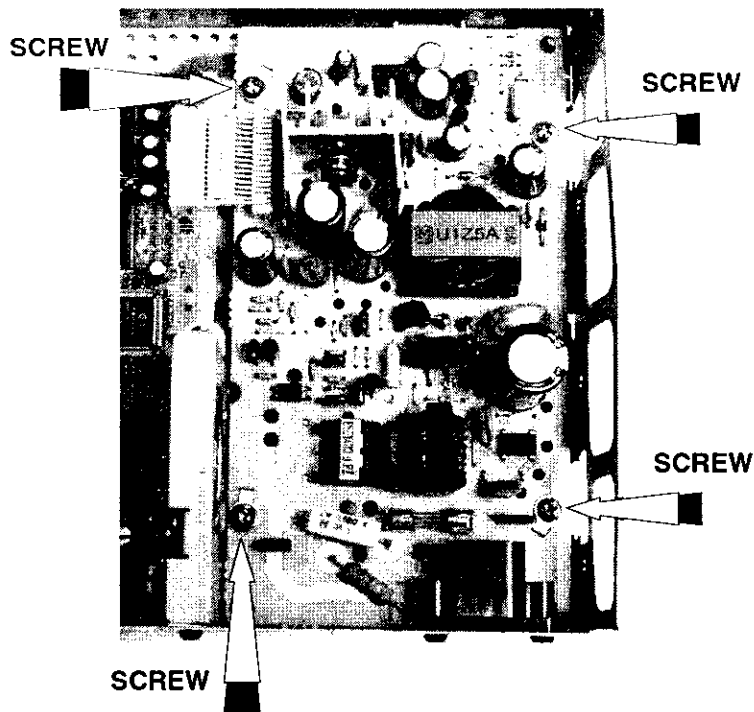

IMPORTANT:
Keep and re-use all hardware from original set (screws, nuts, washers).

FAN

The FAN is assembled to a metallic base with two screws; this metallic base is assembled to the A-Board with one screw to the bottom chassis and one screw to the back of the chassis

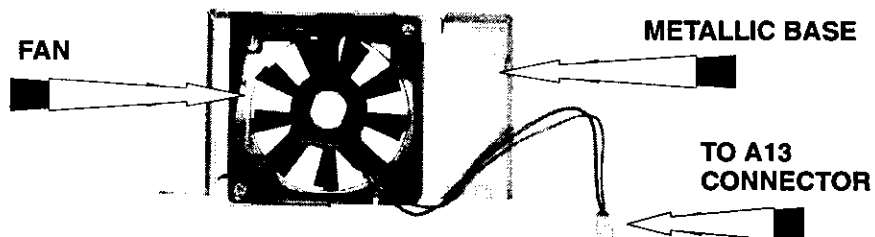
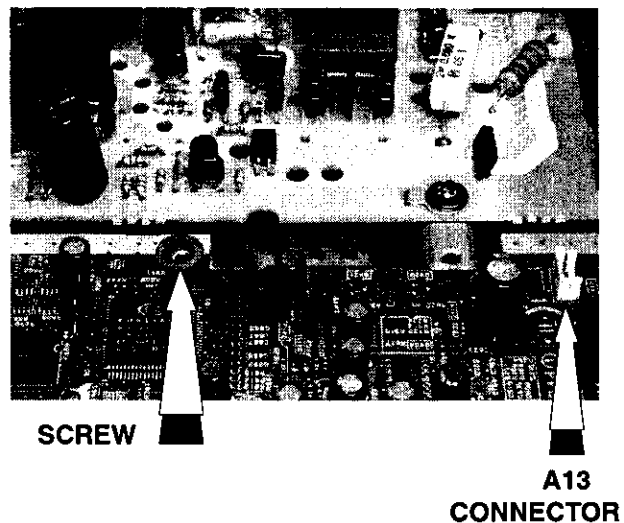
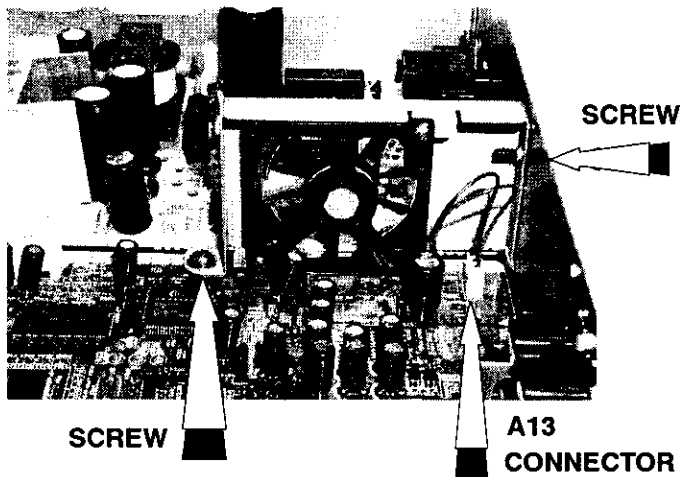

BOTTOM VIEW

The bottom chassis include 4 rubber-feet, they are placed in the four corners on the base of the chassis.

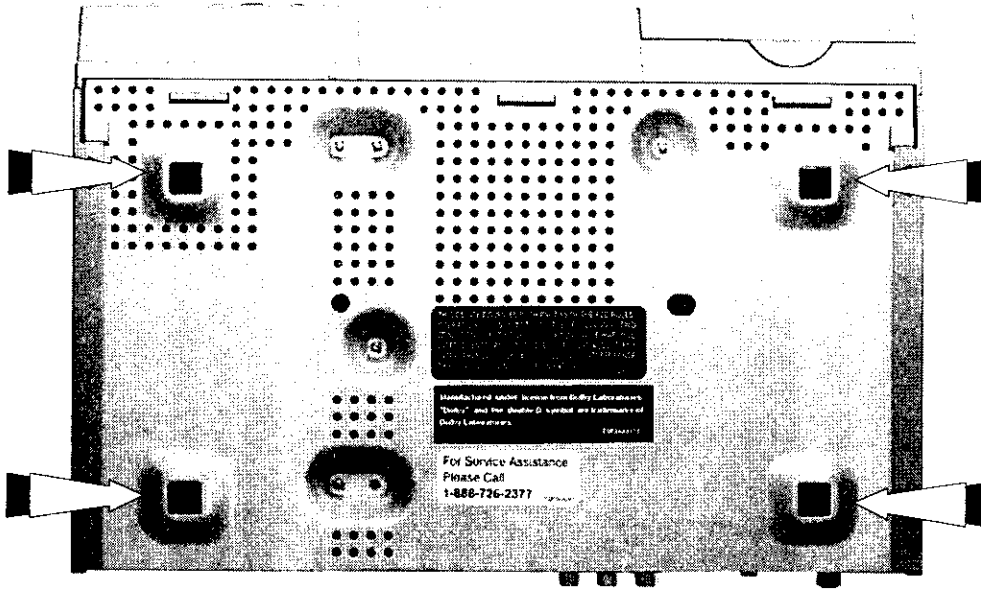

PACKING BOX

Assembly the box as shown:

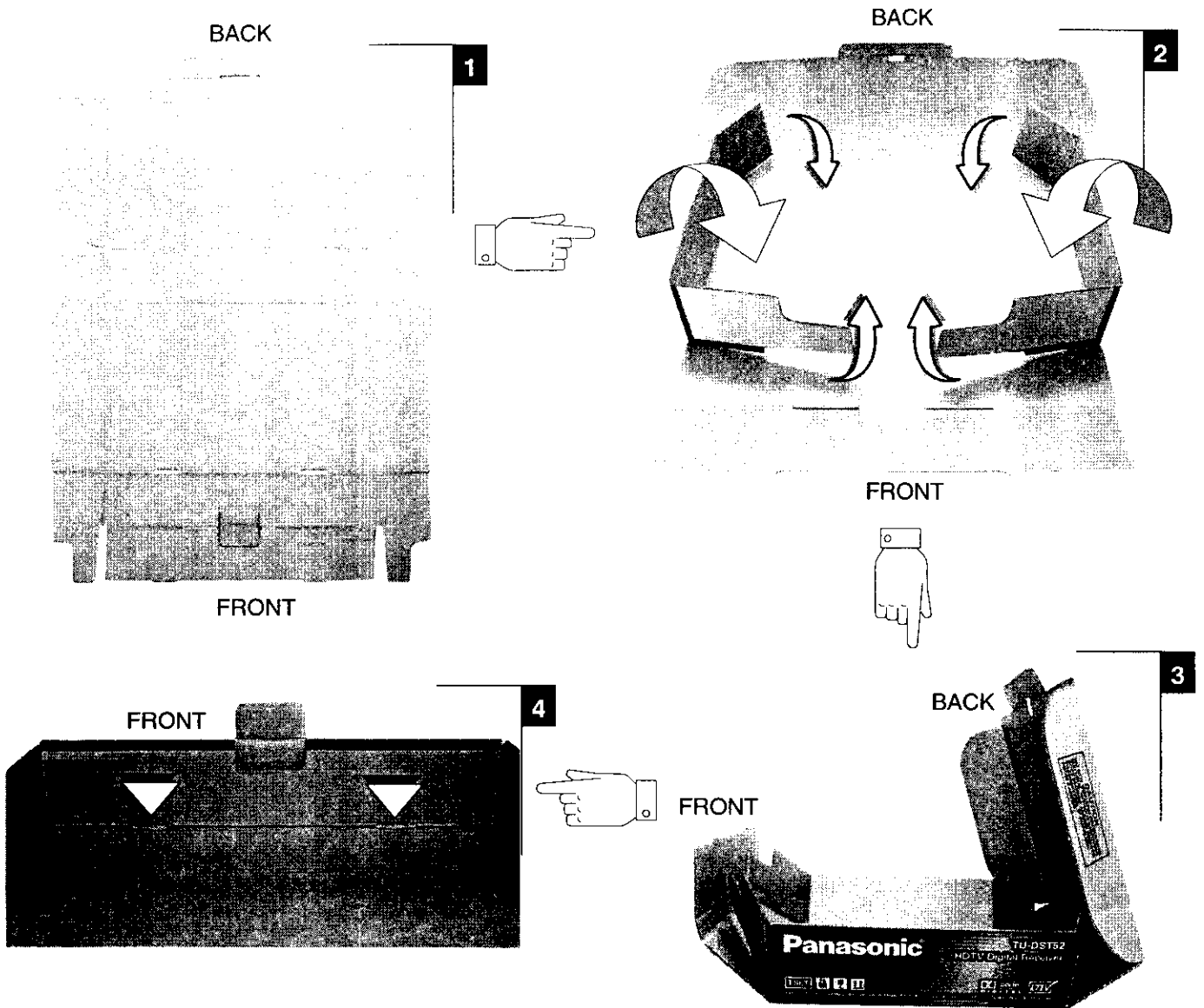

CUSHION BOX

Assembly the cushion box as shown.

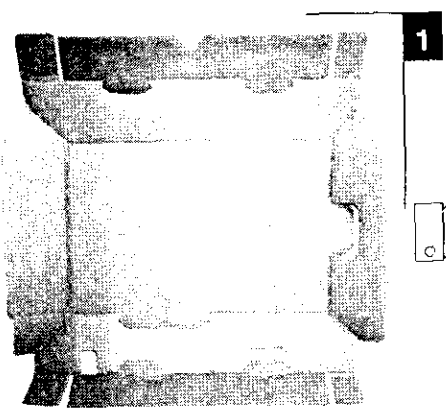

TOP VIEW

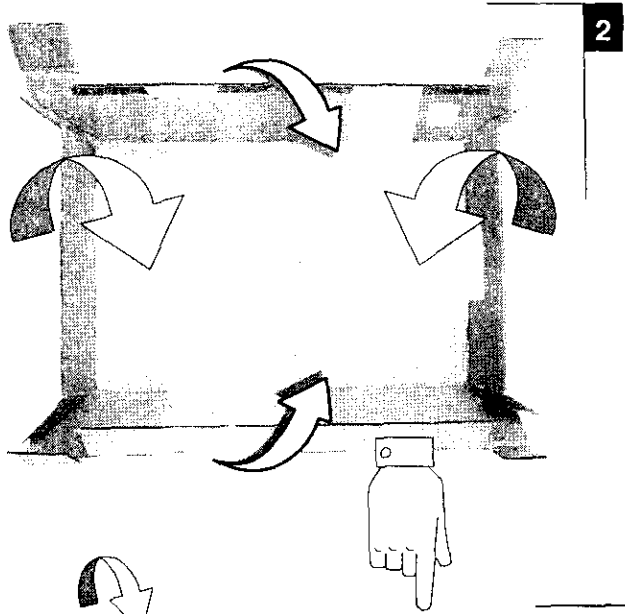

SIDE VIEW

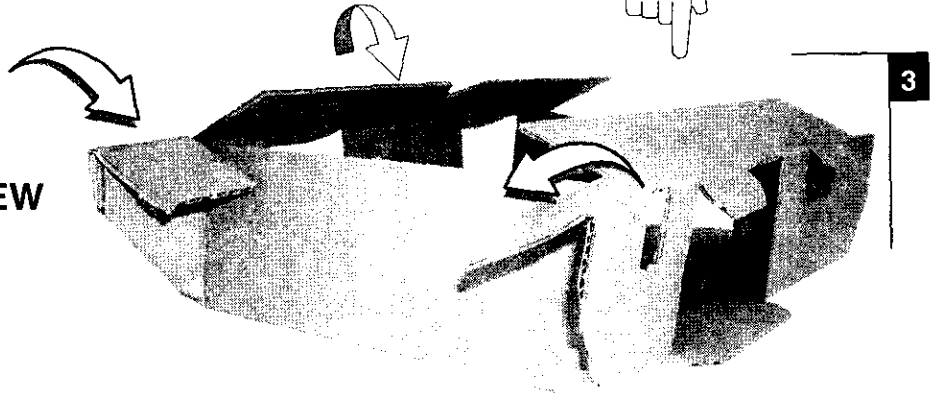

FRONT

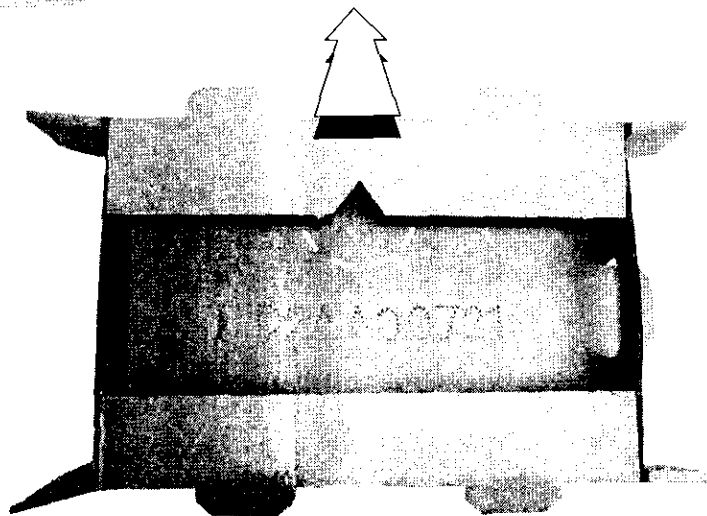
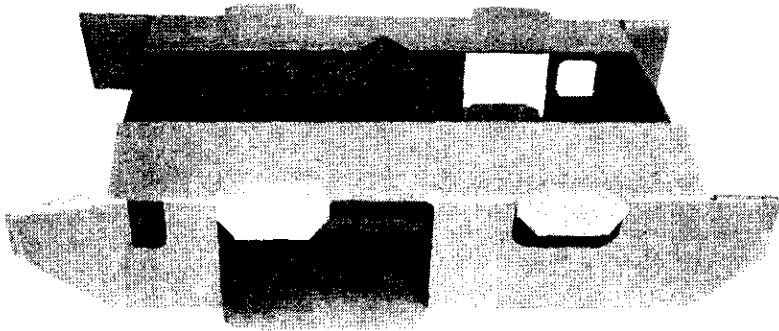

PACKING

Insert the cushion box into the packing box as shown.
Place the reinforcement carton on the rear side of the assembly.
Keep the notch of the cushion box to the front.
Place the remote control on the left side and the AC cord on the right side.

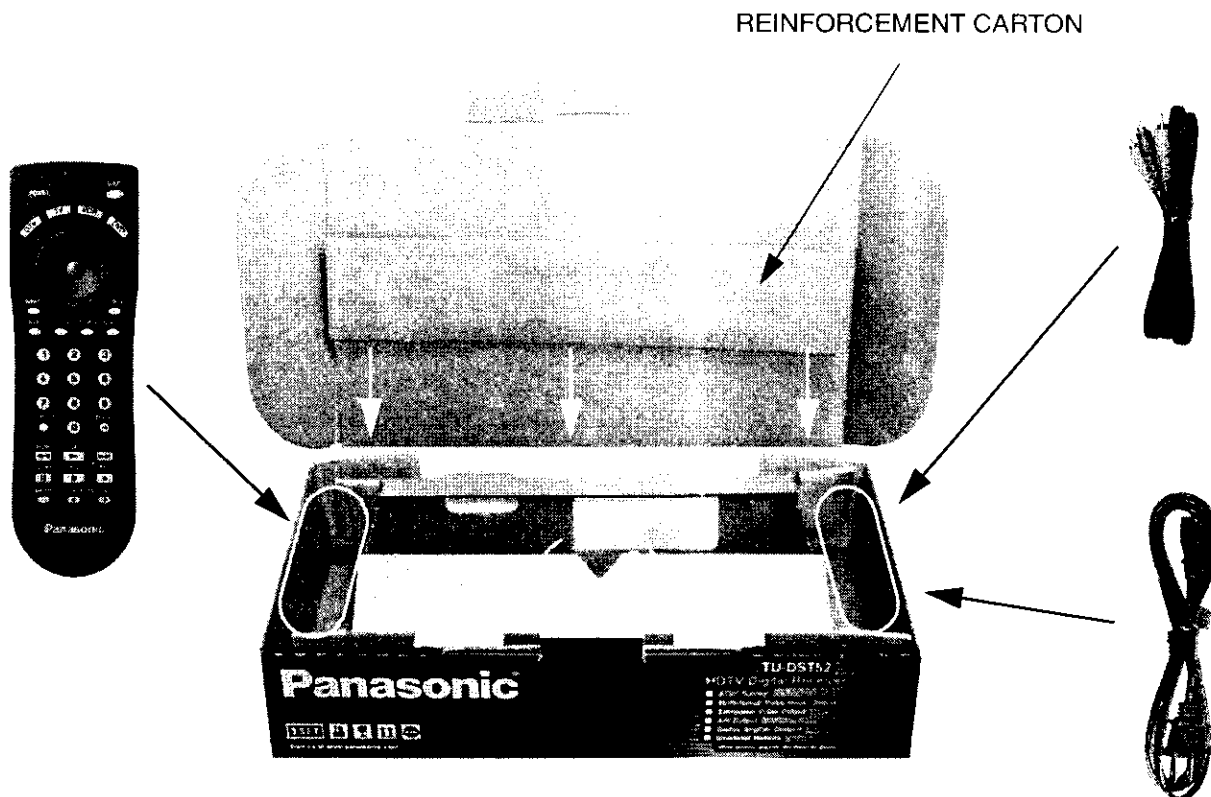

PACKING THE SET

Place the set inside the plastic bag (450x400mm) and fold the remaining bag on top of the set and fix it with tape as shown.

The fanbag (manuals, warranty, service center sheet, etc.) should be placed on top of the set.

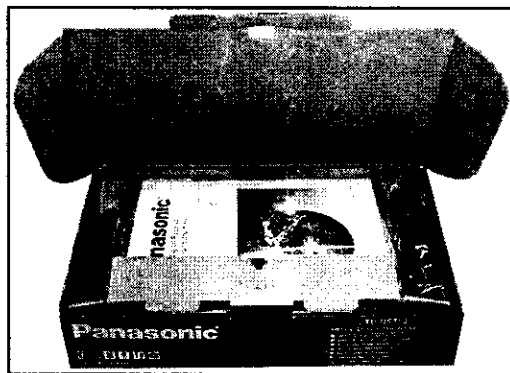
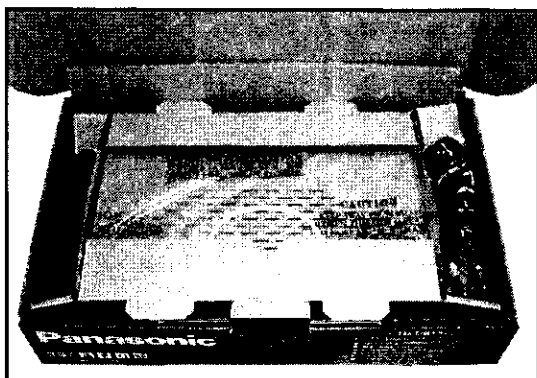

REPLACEMENT PARTS LIST FOR REBURBISHED

REF. No.	PART NO.	DESCRIPTION
M001	EUR7613Z50	REMOTE CONTROL
M002	UR76EC0303A	BATTERY COVER, REMOTE CONTROL
M003	TBLG3017	FOOT, RUBBER
M004	TBXA19603A	BUTTON
M005	TESA070-1	GND SPRING
M006	TKF2AA00103	TOP COVER
M007	TKP2AA0494S	FRONT PANEL
M008	TKP2AA0501	LED PANEL
M009	TKP2AA0771	MODE LED PANEL
M010	TKX2AA0111	IR GUIDE
M011	TPC2AA1024	PKG, CARTON
M012	TPD2AA00721	PKG, CUSHION
M013	TPD2AG0181	PKG, REINFORCEMENT
M014	TPE2AH0031	BAG PLASTIC 450X400
M015	TPE2A40055	PKG, BAG 9.5 X 14
M016	TQB2AA0446-1	MANUAL, OWNERS
M017	TQD2A81701-2	CARD, REGISTRATION
M018	TSXF094	ASSY, A/V CABLE
M019	TSXL092	CABLE ASSY. A2-V2
M020	TSX2AA0261	LINE CORD, AC
M021	TUA2AA0034	BOTTOM CHASSIS
M022	TUX2AX0111	BRKT, FAN
M023	UM-3DPA/T	BATTERY (AA)
M024	UDQFSEH57	FAN
M025	0WG95FN	WSHR, RND (9.5X 12.7)
M026	0NG38AFN	NUT, HEX(3/8-32)
M027	04F32219	TAPE, ADHES. POLYESTER
M028	XTV3+8JFZ	BATTERY (AA)
M029	XTV2.6+6JFX	SCREWS (FOR FAN)
M030	XTW3+8J	SCREWS
M031	TNP2AA115S	P-BOARD
M032	TNP2AA116S	K-BOARD
M033	TNP2AH044S	A-BOARD

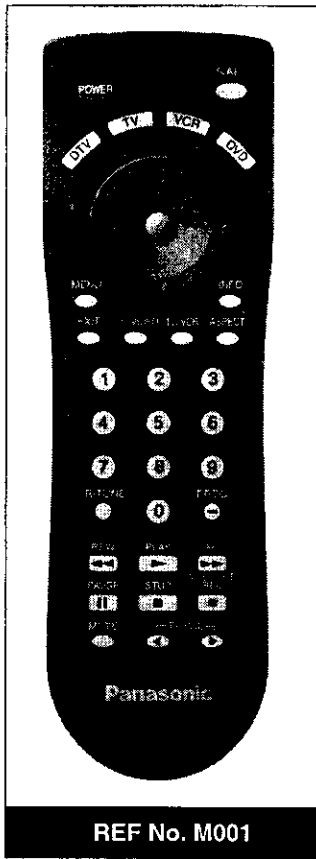

REF No. M001

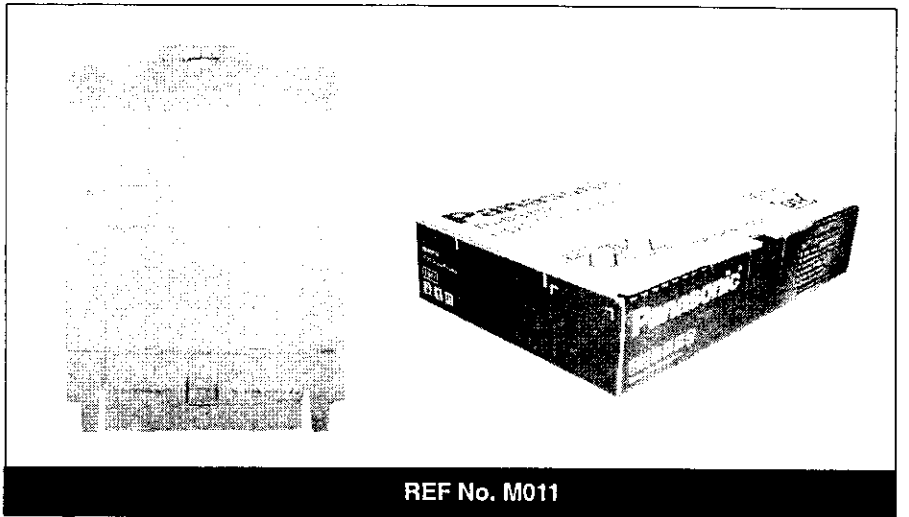

REF No. M011

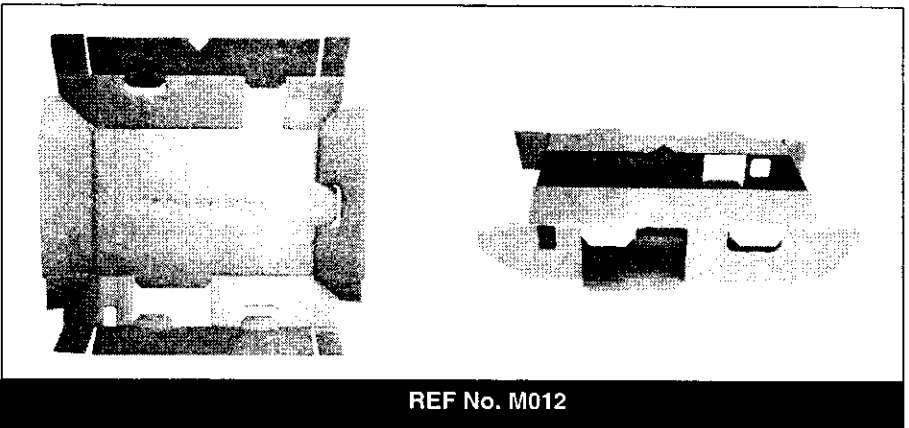

REF No. M012

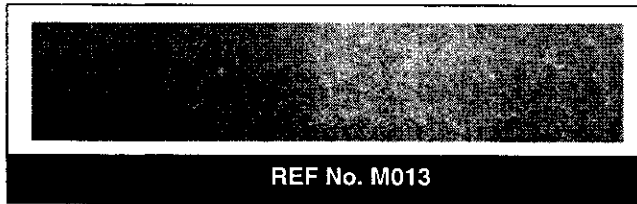

REF No. M013

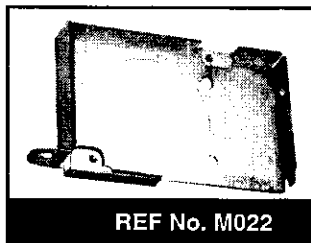

REF No. M022



REF No. M020

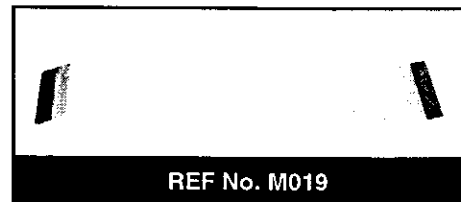
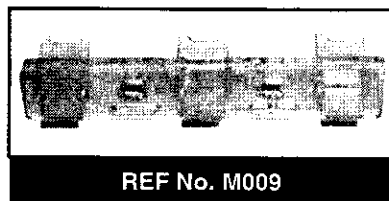
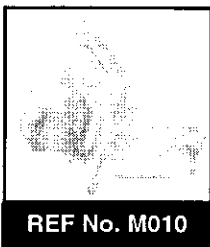
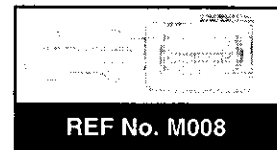
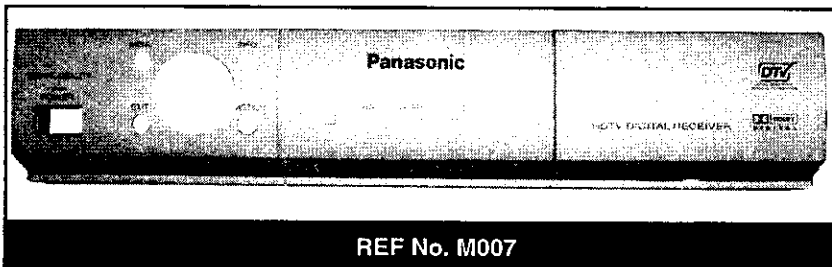
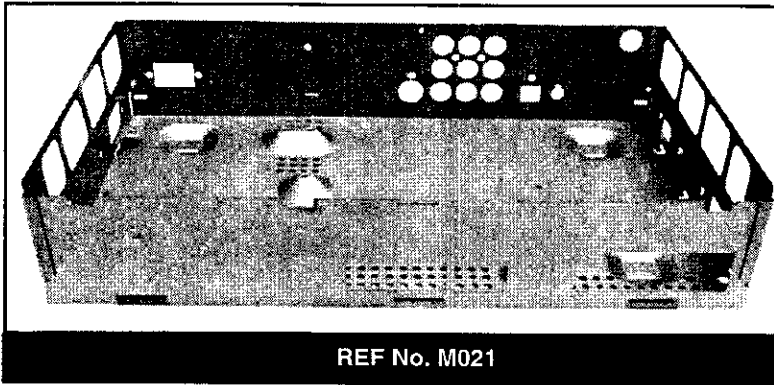
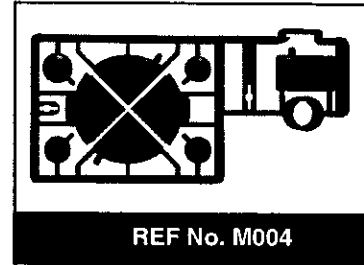
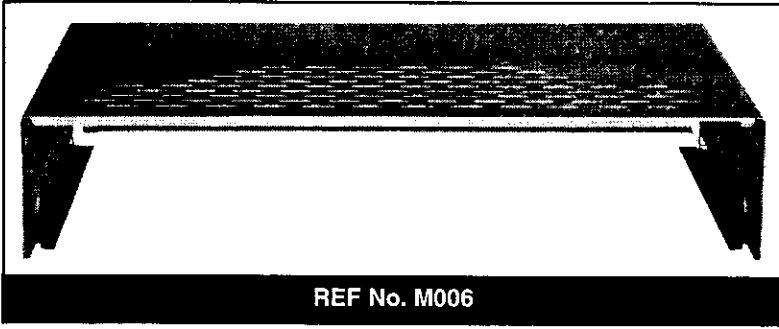

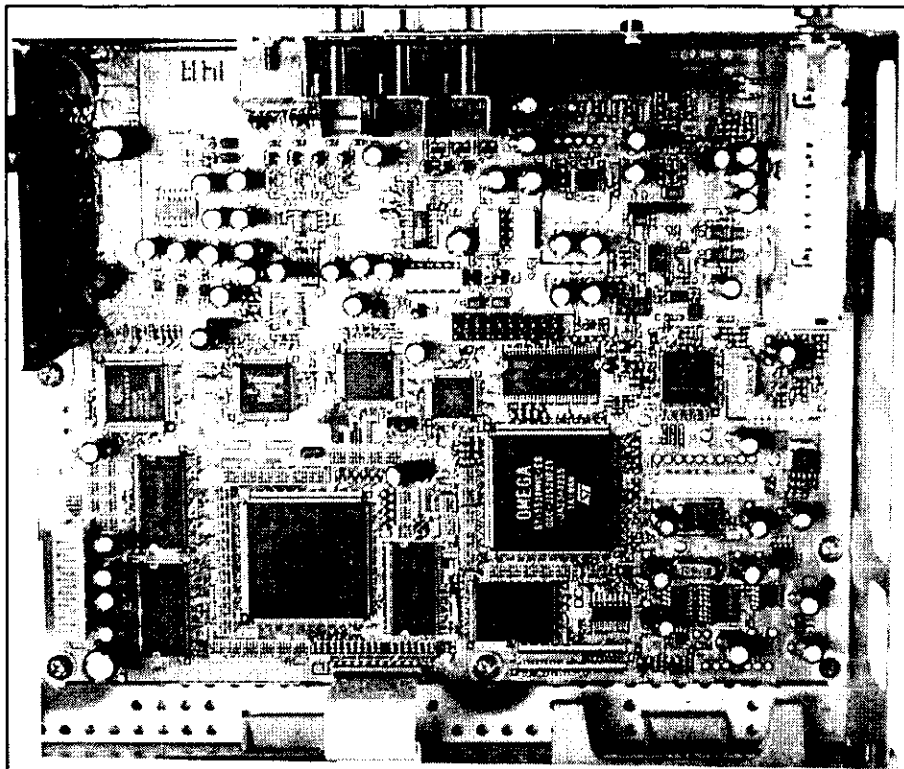

REF No. M033

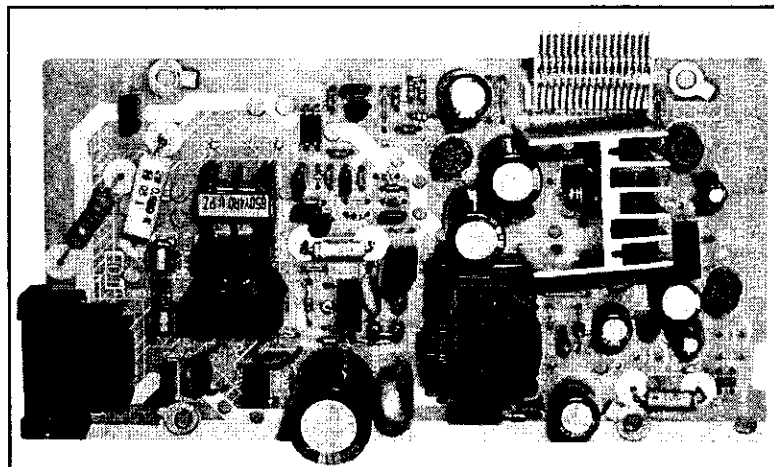

REF No. M031

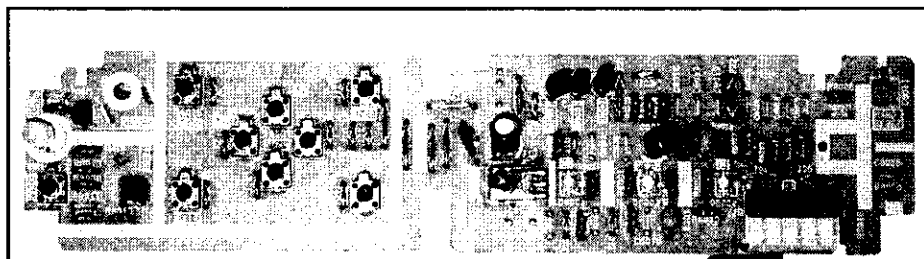

REF No. M032

COMPLETE REPLACEMENT PARTS LIST

Model: TU-DST52F

Important Safety Notice: Components printed in **BOLD TYPE** have special characteristics important for safety. When replacing any of these components use only manufacturer's specified parts.

REF NO.	PART NO.	DESCRIPTION
CAPRISTORS		
CRA9801	TP00842-51	SPARK GAP
CRA9802	TP00842-51	SPARK GAP
CAPACITORS		
C8001	EEAGA1A101B	CAP,E 100UF-10V
C8002	ECKR1H103ZF5	CAP,C .01UF-Z-50V
C8003	EEAGA1A101B	CAP,E 100UF-10V
C8004	ECKR1H103ZF5	CAP,C .01UF-Z-50V
C8400	ECA1CM101B	CAP,E 100UF/16V
C8401	ECA1CM101B	CAP,E 100UF/16V
C8402	ECA1CM101B	CAP,E 100UF/16V
C8403	ECA1CM101B	CAP,E 100UF/16V
C8404	ECA1HM101B	CAP,E 100UF-50V
C8405	ECA1HM100B	CAP,E 10UF/50V
C8406	ECJ2VF1C104Z	CAP,C .1UF-Z-16V
C8407	ECA1HM100B	CAP,E 10UF/50V
C8408	ECA1HM100B	CAP,E 10UF/50V
C8409	ECJ2VF1C104Z	CAP,C .1UF-Z-16V
C8410	ECJ2VF1C104Z	CAP,C .1UF-Z-16V
C8411	ECJ1VF1C104Z	CAP,C .10UF-Z-16V
C8412	ECJ2VF1C104Z	CAP,C .1UF-Z-16V
C8413	ECJ2VF1H104Z	CAP,C .1UF-Z-50V
C8414	ECA1HM100B	CAP,E 10UF/50V
C8415	ECA1HM100B	CAP,E 10UF/50V
C8416	ECA1HM100B	CAP,E 10UF/50V
C8417	ECJ2VF1C104Z	CAP,C .1UF-Z-16V
C8418	ECJ2VF1C104Z	CAP,C .1UF-Z-16V
C8419	ECJ2VF1H104Z	CAP,C .1UF-Z-50V
C8420	ECJ2VF1C105Z	CAP,C 1.0UF-Z-16V
C8421	ECJ1VF1A105Z	CAP,C 1UF-Z-125V
C8422	ECJ1VF1H103Z	CAP,C .010UF-Z-50V
C8423	ECJ1VF1H103Z	CAP,C .010UF-Z-50V
C8428	ECJ1VF1H103Z	CAP,C .010UF-Z-50V
C8429	ECJ1VF1H103Z	CAP,C .010UF-Z-50V
C8430	ECJ1VF1C104Z	CAP,C .10UF-Z-16V
C8432	ECJ1VF1C104Z	CAP,C .10UF-Z-16V
C8433	ECJ1VF1H103Z	CAP,C .010UF-Z-50V
C8434	ECJ1VF1H103Z	CAP,C .010UF-Z-50V
C8435	ECJ1VF1A105Z	CAP,C 1UF-Z-125V
C8436	ECJ1VF1H103Z	CAP,C .010UF-Z-50V
C8437	ECJ1VF1H103Z	CAP,C .010UF-Z-50V
C8438	TCJ2VC1H101J	CAP,C 100PF-J-50V
C8439	TCJ2VC1H101J	CAP,C 100PF-J-50V
C8440	TCJ2VC1H101J	CAP,C 100PF-J-50V
C8441	TCJ2VC1H101J	CAP,C 100PF-J-50V
C8442	TCJ2VC1H101J	CAP,C 100PF-J-50V
C8443	TCJ2VC1H101J	CAP,C 100PF-J-50V
C8444	TCJ2VC1H101J	CAP,C 100PF-J-50V
C8445	TCJ2VC1H101J	CAP,C 100PF-J-50V
C8446	TCJ2VC1H101J	CAP,C 100PF-J-50V
C8448	ECJ1VF1A105Z	CAP,C 1UF-Z-125V

REF NO.	PART NO.	DESCRIPTION
C8449	ECJ1VC1H101J	CAP,C 100PF-J-50V
C8450	TCJ2VC1H101J	CAP,C 100PF-J-50V
C8451	TCJ2VC1H101J	CAP,C 100PF-J-50V
C8452	TCJ2VC1H101J	CAP,C 100PF-J-50V
C8453	ECJ1VC1H101J	CAP,C 100PF-J-50V
C8454	TCJ2VC1H101J	CAP,C 100PF-J-50V
C8455	TCJ2VC1H101J	CAP,C 100PF-J-50V
C8456	ECJ2VF1C104Z	CAP,C .1UF-Z-16V
C8457	ECJ2VF1C104Z	CAP,C .1UF-Z-16V
C8458	ECJ2VF1C104Z	CAP,C .1UF-Z-16V
C8459	ECJ2VF1C104Z	CAP,C .1UF-Z-16V
C8460	ECJ2VF1C104Z	CAP,C .1UF-Z-16V
C8461	ECA1CM101B	CAP,E 100UF/16V
C8462	ECJ2VF1C104Z	CAP,C .1UF-Z-16V
C8463	ECJ1VF1H103Z	CAP,C .010UF-Z-50V
C8465	ECA1CM101B	CAP,E 100UF/16V
C8466	ECJ1VF1C104Z	CAP,C .10UF-Z-16V
C8467	ECJ2VF1H103Z	CAP,C .01UF-Z-50V
C8468	ECJ2VF1H103Z	CAP,C .01UF-Z-50V
C8471	ECA1HM100B	CAP,E 10UF/50V
C8472	ECJ2VF1C104Z	CAP,C .1UF-Z-16V
C8473	ECJ1VF1C104Z	CAP,C .10UF-Z-16V
C8474	ECJ1VF1C104Z	CAP,C .10UF-Z-16V
C8475	ECA1HM100B	CAP,E 10UF/50V
C8476	ECJ2VF1C104Z	CAP,C .1UF-Z-16V
C8477	ECA1VM470B	CAP,E 47UF/35V
C8479	ECJ1VC1H181J	CAP,C 180PF-J-50V
C8480	ECJ1VC1H101J	CAP,C 100PF-J-50V
C8481	ECJ1VC1H060C	CAP,C 6PF-C-50V
C8482	ECJ1VC1H150J	CAP,C 15PF-J-50V
C8483	ECJ1VC1H060C	CAP,C 6PF-C-50V
C8484	ECJ1VC1H101J	CAP,C 100PF-J-50V
C8485	ECJ1VC1H220J	CAP,C 22PF-J-50V
C8486	ECA1HM100B	CAP,E 10UF/50V
C8487	ECJ2VF1C104Z	CAP,C .1UF-Z-16V
C8488	ECA1CM470B	CAP,E 47UF/16V
C8490	ECA1HM100B	CAP,E 10UF/50V
C8492	ECJ2VF1C104Z	CAP,C .1UF-Z-16V
C8493	ECJ1VF1A105Z	CAP,C 1UF-Z-125V
C8494	ECJ1VF1A105Z	CAP,C 1UF-Z-125V
C8495	ECA1CM101B	CAP,E 100UF/16V
C8497	ECA1HM100B	CAP,E 10UF/50V
C8498	ECJ2VF1C104Z	CAP,C .1UF-Z-16V
C8499	ECJ1VF1C104Z	CAP,C .10UF-Z-16V
C8500	ECJ2VF1C104Z	CAP,C .1UF-Z-16V
C8501	ECJ2VF1C104Z	CAP,C .1UF-Z-16V
C8502	ECJ2VF1C104Z	CAP,C .1UF-Z-16V
C8503	ECJ2VC1H270J	CAP,C 27PF-J-50V
C8504	ECJ2VC1H270J	CAP,C 27PF-J-50V
C8505	ECJ1VF1C104Z	CAP,C .10UF-Z-16V
C8506	ECJ2VF1C104Z	CAP,C .1UF-Z-16V

COMPLETE REPLACEMENT PARTS LIST

Model: TU-DST52F

Important Safety Notice: Components printed in **BOLD TYPE** have special characteristics important for safety. When replacing any of these components use only manufacturer's specified parts.

REF NO.	PART NO.	DESCRIPTION
C8507	ECJ2VF1C104Z	CAP,C .1UF-Z-16V
C8508	ECJ1VF1C104Z	CAP,C .10UF-Z-16V
C8509	ECJ1VF1C104Z	CAP,C .10UF-Z-16V
C8510	ECJ2VF1C104Z	CAP,C .1UF-Z-16V
C8511	ECJ1VF1C104Z	CAP,C .10UF-Z-16V
C8512	ECJ2VF1C105Z	CAP,C 1.0UF-Z-16V
C8513	ECJ2VF1C105Z	CAP,C 1.0UF-Z-16V
C8514	ECJ2VF1C105Z	CAP,C 1.0UF-Z-16V
C8515	ECJ1VF1C104Z	CAP,C .10UF-Z-16V
C8516	ECJ2VF1C104Z	CAP,C .1UF-Z-16V
C8517	ECA1VM470B	CAP,E 47UF/35V
C8518	ECJ1VF1C104Z	CAP,C .10UF-Z-16V
C8519	ECJ1VF1C104Z	CAP,C .10UF-Z-16V
C8521	ECJ1VF1C104Z	CAP,C .10UF-Z-16V
C8522	ECJ2VF1C104Z	CAP,C .1UF-Z-16V
C8523	ECJ2VF1C104Z	CAP,C .1UF-Z-16V
C8524	ECJ2VF1C104Z	CAP,C .1UF-Z-16V
C8525	ECJ2VF1C104Z	CAP,C .1UF-Z-16V
C8526	ECJ1VF1C104Z	CAP,C .10UF-Z-16V
C8527	ECJ1VF1C104Z	CAP,C .10UF-Z-16V
C8529	ECJ1VF1C104Z	CAP,C .10UF-Z-16V
C8530	ECJ1VF1C104Z	CAP,C .10UF-Z-16V
C8532	ECJ1VF1C104Z	CAP,C .10UF-Z-16V
C8533	ECJ2VF1C104Z	CAP,C .1UF-Z-16V
C8534	ECJ2VF1C104Z	CAP,C .1UF-Z-16V
C8535	ECJ2VF1C104Z	CAP,C .1UF-Z-16V
C8536	ECJ1VF1C104Z	CAP,C .10UF-Z-16V
C8537	ECJ1VF1C104Z	CAP,C .10UF-Z-16V
C8538	ECJ1VF1C104Z	CAP,C .10UF-Z-16V
C8539	ECJ1VF1C104Z	CAP,C .10UF-Z-16V
C8540	ECJ1VF1C104Z	CAP,C .10UF-Z-16V
C8541	ECJ2VF1C104Z	CAP,C .1UF-Z-16V
C8542	ECJ2VF1C104Z	CAP,C .1UF-Z-16V
C8543	ECJ2VF1C104Z	CAP,C .1UF-Z-16V
C8544	ECJ2VF1C104Z	CAP,C .1UF-Z-16V
C8545	ECJ2VF1C104Z	CAP,C .1UF-Z-16V
C8546	ECJ2VF1C104Z	CAP,C .1UF-Z-16V
C8547	ECJ2VF1C104Z	CAP,C .1UF-Z-16V
C8548	ECJ1VF1C104Z	CAP,C .10UF-Z-16V
C8549	ECJ2VF1C104Z	CAP,C .1UF-Z-16V
C8550	ECJ1VF1C104Z	CAP,C .10UF-Z-16V
C8551	ECJ2VF1C104Z	CAP,C .1UF-Z-16V
C8552	ECJ1VF1C104Z	CAP,C .10UF-Z-16V
C8553	ECJ2VF1C104Z	CAP,C .1UF-Z-16V
C8554	ECJ2VF1C104Z	CAP,C .1UF-Z-16V
C8555	ECJ1VF1C104Z	CAP,C .10UF-Z-16V
C8556	ECJ2VF1C104Z	CAP,C .1UF-Z-16V
C8557	ECJ2VC1H220J	CAP,C 22PF-J-50V
C8558	ECJ1VF1C104Z	CAP,C .10UF-Z-16V
C8559	ECJ1VF1C104Z	CAP,C .10UF-Z-16V
C8560	ECJ1VF1C104Z	CAP,C .10UF-Z-16V

REF NO.	PART NO.	DESCRIPTION
C8561	ECJ1VF1C104Z	CAP,C .10UF-Z-16V
C8562	ECJ1VF1C104Z	CAP,C .10UF-Z-16V
C8563	ECA1VM470B	CAP,E 47UF/35V
C8564	ECJ2VF1C104Z	CAP,C .1UF-Z-16V
C8565	ECA1HM010B	CAP,E 1UF-50V
C8566	ECJ2VF1C104Z	CAP,C .1UF-Z-16V
C8567	ECJ2VF1C104Z	CAP,C .1UF-Z-16V
C8568	ECJ2VF1C104Z	CAP,C .1UF-Z-16V
C8570	ECJ2VF1C104Z	CAP,C .1UF-Z-16V
C8571	ECJ2VF1C104Z	CAP,C .1UF-Z-16V
C8572	ECJ2VF1C104Z	CAP,C .1UF-Z-16V
C8573	ECJ2VF1C104Z	CAP,C .1UF-Z-16V
C8574	ECJ2VF1C104Z	CAP,C .1UF-Z-16V
C8575	ECJ2VF1C104Z	CAP,C .1UF-Z-16V
C8576	ECJ2VF1C104Z	CAP,C .1UF-Z-16V
C8577	ECJ1VF1C104Z	CAP,C .10UF-Z-16V
C8578	ECJ2VF1C104Z	CAP,C .1UF-Z-16V
C8579	ECJ2VF1C104Z	CAP,C .1UF-Z-16V
C8580	ECJ2VF1C104Z	CAP,C .1UF-Z-16V
C8581	ECJ2VF1C104Z	CAP,C .1UF-Z-16V
C8582	ECJ2VF1C104Z	CAP,C .1UF-Z-16V
C8583	ECJ2VF1C104Z	CAP,C .1UF-Z-16V
C8584	ECJ1VF1C104Z	CAP,C .10UF-Z-16V
C8585	ECJ1VF1C104Z	CAP,C .10UF-Z-16V
C8586	ECJ2VF1C104Z	CAP,C .1UF-Z-16V
C8587	ECJ2VF1C104Z	CAP,C .1UF-Z-16V
C8588	ECJ2VF1C104Z	CAP,C .1UF-Z-16V
C8589	ECJ2VF1C104Z	CAP,C .1UF-Z-16V
C8590	ECJ2VF1C104Z	CAP,C .1UF-Z-16V
C8591	ECJ2VF1C104Z	CAP,C .1UF-Z-16V
C8592	ECJ2VF1C104Z	CAP,C .1UF-Z-16V
C8593	ECJ2VF1C104Z	CAP,C .1UF-Z-16V
C8594	ECJ1VF1C104Z	CAP,C .10UF-Z-16V
C8595	ECJ1VF1C104Z	CAP,C .10UF-Z-16V
C8597	ECJ2VF1C104Z	CAP,C .1UF-Z-16V
C8598	ECJ2VF1C104Z	CAP,C .1UF-Z-16V
C8599	ECJ2VF1C104Z	CAP,C .1UF-Z-16V
C8600	ECJ2VF1C104Z	CAP,C .1UF-Z-16V
C8601	ECJ2VF1C104Z	CAP,C .1UF-Z-16V
C8602	ECJ2VF1C104Z	CAP,C .1UF-Z-16V
C8603	ECJ2VF1C104Z	CAP,C .1UF-Z-16V
C8604	ECJ2VF1C104Z	CAP,C .1UF-Z-16V
C8606	ECA1VM470B	CAP,E 47UF/35V
C8608	ECJ2VF1C104Z	CAP,C .1UF-Z-16V
C8613	ECJ1VF1C104Z	CAP,C .10UF-Z-16V
C8616	ECJ2VF1C104Z	CAP,C .1UF-Z-16V
C8622	ECJ2VF1C104Z	CAP,C .1UF-Z-16V
C8624	ECJ2VF1C104Z	CAP,C .1UF-Z-16V
C8625	ECJ2VF1C104Z	CAP,C .1UF-Z-16V
C8626	ECJ2VF1C104Z	CAP,C .1UF-Z-16V
C8627	ECJ2VF1C104Z	CAP,C .1UF-Z-16V

COMPLETE REPLACEMENT PARTS LIST

Model: TU-DST52F

Important Safety Notice: Components printed in **BOLD TYPE** have special characteristics important for safety. When replacing any of these components use only manufacturer's specified parts.

REF NO.	PART NO.	DESCRIPTION
C8628	ECJ2VF1C104Z	CAP,C .1UF-Z-16V
C8629	ECJ2VF1C104Z	CAP,C .1UF-Z-16V
C8630	ECJ2VF1C104Z	CAP,C .1UF-Z-16V
C8631	ECJ2VF1C104Z	CAP,C .1UF-Z-16V
C8632	ECJ2VF1C104Z	CAP,C .1UF-Z-16V
C8633	ECJ2VF1C104Z	CAP,C .1UF-Z-16V
C8634	ECJ2VF1C104Z	CAP,C .1UF-Z-16V
C8635	ECJ2VF1C104Z	CAP,C .1UF-Z-16V
C8636	ECJ2VF1C104Z	CAP,C .1UF-Z-16V
C8637	ECJ2VF1C104Z	CAP,C .1UF-Z-16V
C8638	ECJ2VF1C104Z	CAP,C .1UF-Z-16V
C8639	ECJ2VF1C104Z	CAP,C .1UF-Z-16V
C8640	ECJ2VF1C104Z	CAP,C .1UF-Z-16V
C8641	ECJ2VF1C104Z	CAP,C .1UF-Z-16V
C8642	ECJ2VF1C104Z	CAP,C .1UF-Z-16V
C8643	ECJ2VF1C104Z	CAP,C .1UF-Z-16V
C8644	ECJ2VF1C104Z	CAP,C .1UF-Z-16V
C8645	ECJ2VF1C104Z	CAP,C .1UF-Z-16V
C8646	ECJ2VF1C104Z	CAP,C .1UF-Z-16V
C8647	ECJ2VF1C104Z	CAP,C .1UF-Z-16V
C8648	ECJ1VF1C104Z	CAP,C .10UF-Z-16V
C8649	ECJ1VF1C104Z	CAP,C .10UF-Z-16V
C8650	ECJ2VF1C104Z	CAP,C .1UF-Z-16V
C8651	ECJ2VF1C104Z	CAP,C .1UF-Z-16V
C8652	ECJ2VF1C104Z	CAP,C .1UF-Z-16V
C8653	ECJ1VF1C104Z	CAP,C .10UF-Z-16V
C8654	ECJ2VF1C104Z	CAP,C .1UF-Z-16V
C8655	ECJ1VF1C104Z	CAP,C .10UF-Z-16V
C8656	ECJ1VF1C104Z	CAP,C .10UF-Z-16V
C8657	ECJ1VF1A105Z	CAP,C 1UF-Z-125V
C8658	ECJ2VF1C104Z	CAP,C .1UF-Z-16V
C8659	ECJ2VF1C104Z	CAP,C .1UF-Z-16V
C8660	ECJ2VF1C104Z	CAP,C .1UF-Z-16V
C8661	ECJ1VF1C104Z	CAP,C .10UF-Z-16V
C8662	ECJ2VF1C104Z	CAP,C .1UF-Z-16V
C8663	ECJ1VF1C104Z	CAP,C .10UF-Z-16V
C8664	ECJ2VF1C104Z	CAP,C .1UF-Z-16V
C8665	ECJ1VF1C104Z	CAP,C .10UF-Z-16V
C8666	ECJ1VF1C104Z	CAP,C .10UF-Z-16V
C8667	ECJ1VF1C104Z	CAP,C .10UF-Z-16V
C8668	ECJ2VF1C104Z	CAP,C .1UF-Z-16V
C8669	ECJ2VF1C104Z	CAP,C .1UF-Z-16V
C8670	ECJ1VF1C104Z	CAP,C .10UF-Z-16V
C8671	ECJ1VF1C104Z	CAP,C .10UF-Z-16V
C8672	ECJ1VF1C104Z	CAP,C .10UF-Z-16V
C8673	ECJ2VF1C104Z	CAP,C .1UF-Z-16V
C8674	ECJ2VF1C104Z	CAP,C .1UF-Z-16V
C8675	ECJ2VF1C104Z	CAP,C .1UF-Z-16V
C8676	ECJ2VF1C104Z	CAP,C .1UF-Z-16V
C8677	ECJ2VF1C104Z	CAP,C .1UF-Z-16V
C8678	ECJ2VF1C104Z	CAP,C .1UF-Z-16V

REF NO.	PART NO.	DESCRIPTION
C8681	ECA1CM101B	CAP,E 100UF/16V
C8682	ECA1CM101B	CAP,E 100UF/16V
C8683	ECJ2VF1C104Z	CAP,C .1UF-Z-16V
C8684	ECJ2VF1C104Z	CAP,C .1UF-Z-16V
C8685	ECA1CM101B	CAP,E 100UF/16V
C8686	ECA1VM470B	CAP,E 47UF/35V
C8687	ECA1CM101B	CAP,E 100UF/16V
C8689	ECJ2VF1H103Z	CAP,C .01UF-Z-50V
C8702	F1J1C1050006	CAP,C 1UF-Z-16V
C8703	F1J1C1050006	CAP,C 1UF-Z-16V
C8704	F1J1C1050006	CAP,C 1UF-Z-16V
C8705	ECA1CM101B	CAP,E 100UF/16V
C8706	ECA1CM101B	CAP,E 100UF/16V
C8707	ECA1HM100B	CAP,E 10UF/50V
C8708	ECA1HM100B	CAP,E 10UF/50V
C8709	ECJ2VF1H103Z	CAP,C .01UF-Z-50V
C8710	ECJ2VF1H103Z	CAP,C .01UF-Z-50V
C8711	ECJ2VF1H103Z	CAP,C .01UF-Z-50V
C8712	ECJ2VF1H103Z	CAP,C .01UF-Z-50V
C8714	ECA1AM331B	CAP,E 330UF-10V
C8715	ECA1AM331B	CAP,E 330UF-10V
C8716	ECA1AM331B	CAP,E 330UF-10V
C8720	ECJ1VC1H050C	CAP,C 5PF-C-50V
C8721	ECJ1VC1H050C	CAP,C 5PF-C-50V
C8722	ECJ1VC1H050C	CAP,C 5PF-C-50V
C8723	ECJ2VC1H330J	CAP,C 33PF-J-50V
C8724	ECJ2VC1H330J	CAP,C 33PF-J-50V
C8725	ECJ2VC1H330J	CAP,C 33PF-J-50V
C8726	ECA1VM470B	CAP,E 47UF/35V
C8727	ECA1VM470B	CAP,E 47UF/35V
C8728	ECA1VM470B	CAP,E 47UF/35V
C8731	ECJ2VF1H103Z	CAP,C .01UF-Z-50V
C8732	ECJ2VF1C104Z	CAP,C .1UF-Z-16V
C8733	ECA1HM100B	CAP,E 10UF/50V
C8734	ECA1HM3R3B	CAP,E 3.3UF-50V
C8735	ECA1HM3R3B	CAP,E 3.3UF-50V
C8736	ECA1HM100B	CAP,E 10UF/50V
C8737	ECJ2VF1C104Z	CAP,C .1UF-Z-16V
C8738	ECJ2VF1H103Z	CAP,C .01UF-Z-50V
C8739	ECJ2VC1H331J	CAP,C 330PF-J-50V
C8740	ECJ2VC1H331J	CAP,C 330PF-J-50V
C8743	ECA1CHG101B	CAP,E 100UF-16V
C8744	ECJ2VF1H103Z	CAP,C .01UF-Z-50V
C8745	ECJ2VF1C104Z	CAP,C .1UF-Z-16V
C8747	ECJ2VF1C104Z	CAP,C .1UF-Z-16V
C8749	ECJ2VF1C104Z	CAP,C .1UF-Z-16V
C8752	ECJ2VF1C104Z	CAP,C .1UF-Z-16V
C8765	ECJ2VF1H103Z	CAP,C .01UF-Z-50V
C8769	ECJ1VF1C104Z	CAP,C .10UF-Z-16V
C8770	ECJ2VF1C104Z	CAP,C .1UF-Z-16V
C8771	ECJ2VF1C104Z	CAP,C .1UF-Z-16V

COMPLETE REPLACEMENT PARTS LIST

Model: TU-DST52F

Important Safety Notice: Components printed in **BOLD TYPE** have special characteristics important for safety. When replacing any of these components use only manufacturer's specified parts.

REF NO.	PART NO.	DESCRIPTION
C8772	ECJ2VF1C104Z	CAP,C .1UF-Z-16V
C8773	ECJ1VF1C104Z	CAP,C .10UF-Z-16V
C8774	ECJ1VF1C104Z	CAP,C .10UF-Z-16V
C8775	ECJ2VF1C104Z	CAP,C .1UF-Z-16V
C8776	ECJ2VF1C104Z	CAP,C .1UF-Z-16V
C8777	ECJ1VF1C104Z	CAP,C .10UF-Z-16V
C8778	ECJ1VF1C104Z	CAP,C .10UF-Z-16V
C8779	ECJ2VF1C104Z	CAP,C .1UF-Z-16V
C8781	ECJ1VF1C104Z	CAP,C .10UF-Z-16V
C8782	ECJ2VF1C104Z	CAP,C .1UF-Z-16V
C8783	ECJ2VF1C104Z	CAP,C .1UF-Z-16V
C8784	ECJ1VF1C104Z	CAP,C .10UF-Z-16V
C8785	ECJ2VF1C104Z	CAP,C .1UF-Z-16V
C8786	ECJ2VF1C104Z	CAP,C .1UF-Z-16V
C8787	ECJ2VF1C104Z	CAP,C .1UF-Z-16V
C8788	ECJ2VF1C104Z	CAP,C .1UF-Z-16V
C8789	ECJ2VF1C104Z	CAP,C .1UF-Z-16V
C8790	ECJ1VF1C104Z	CAP,C .10UF-Z-16V
C8791	ECJ1VF1C104Z	CAP,C .10UF-Z-16V
C8792	ECJ2VF1C104Z	CAP,C .1UF-Z-16V
C8793	ECJ2VF1C104Z	CAP,C .1UF-Z-16V
C8794	ECA1CM101B	CAP,E 100UF/16V
C8795	ECA1CM101B	CAP,E 100UF/16V
C8796	ECJ2VC1H151J	CAP,C 150PF-J-50V
C8797	ECJ2VC1H151J	CAP,C 150PF-J-50V
C8798	ECJ2VC1H151J	CAP,C 150PF-J-50V
C8799	ECJ2VC1H080D	CAP,C 8PF-D-50V
C8800	ECJ2VC1H080D	CAP,C 8PF-D-50V
C8801	ECJ2VC1H080D	CAP,C 8PF-D-50V
C8802	ECJ1VC1H151J	CAP,C 150PF-J-50V
C8803	ECJ2VC1H151J	CAP,C 150PF-J-50V
C8804	ECJ2VC1H151J	CAP,C 150PF-J-50V
C8805	ECJ1VF1C104Z	CAP,C .10UF-Z-16V
C8806	ECJ1VF1C104Z	CAP,C .10UF-Z-16V
C8807	ECJ1VF1C104Z	CAP,C .10UF-Z-16V
C8808	ECA1CM221B	CAP,E 10UF-16V
C8810	ECJ2VC1H102J	CAP,C .001UF-J-50V
C8811	ECJ2VC1H102J	CAP,C .001UF-J-50V
C8812	ECJ1VC1H181J	CAP,C 180PF-J-50V
C8813	ECJ1VC1H220J	CAP,C 22PF-J-50V
C8822	ECJ1VB1C104K	CAP,C .10UF-K-16V
C8823	ECA1HM101B	CAP,E 100UF-50V
C8968	ECA1HM100B	CAP,E 10UF/50V
C8969	ECJ2VB1C104K	CAP,C .1UF-K-16V
C8970	ECJ2VB1C104K	CAP,C .1UF-K-16V
C8971	ECA1HM100B	CAP,E 10UF/50V
C8972	ECA1HM100B	CAP,E 10UF/50V
C8973	ECA1HM100B	CAP,E 10UF/50V
C8974	ECJ2VF1H104Z	CAP,C .1UF-Z-50V
C8975	ECA1HM100B	CAP,E 10UF/50V
C8976	ECJ2VF1H104Z	CAP,C .1UF-Z-50V

REF NO.	PART NO.	DESCRIPTION
C8977	ECJ2VF1C104Z	CAP,C .1UF-Z-16V
C8979	ECJ1VC1H050C	CAP,C 5PF-C-50V
C9802	ECQU2A823BN9	CAP,P .082UF-B-250V
C9803	ECKW2H472PU8	CAP,C .0047UF-P-500V
C9804	ECKW2H472PU8	CAP,C .0047UF-P-500V
C9805	ECA2DHG221E	CAP,E 220UF/200V
C9806	ECKW3D102KBP	CAP,C 1000PF-K-2KV
C9807	ECQV1H223JM3	CAP,P .022UF-J-50V
C9808	ECQV1H473JM3	CAP,P .047UF-J-50V
C9809	ECQV1H104JM3	CAP,P .10UF-J-50V
C9810	ECQV1H104JM3	CAP,P .10UF-J-50V
C9811	ECKCNA222MEB	CAP,C 2200PF-M-125V
C9812	ECKR2H471KB5	CAP,C 470PF-K-500V
C9813	ECKR2H471KB5	CAP,C 470PF-K-500V
C9814	EEUFC0J472E	CAP,E 4700PF-6.3V
C9815	ECA2AHG101B	CAP,E 100UF-100V
C9816	ECKR2H471KB5	CAP,C 470PF-K-500V
C9817	ECQV1H104JM3	CAP,P .10UF-J-50V
C9819	ECKR2H471KB5	CAP,C 470PF-K-500V
C9820	ECA1CHG102B	CAP,E 1000UF-16V
C9821	ECA1CHG471B	CAP,E 470UF-16V
C9823	ECA1AHG222B	CAP,E 2200UF-10V
C9824	ECA1EHG470B	CAP,E 47UF-25V
C9825	ECKR1H103ZF5	CAP,C .01UF-Z-50V
C9826	ECKR1H103ZF5	CAP,C .01UF-Z-50V
C9828	ECA1EHG470B	CAP,E 47UF-25V
C9830	ECKR1H103ZF5	CAP,C .01UF-Z-50V
C9832	EEUFC0J472E	CAP,E 4700PF-6.3V
DIODES		
D8001	LNG401NPY	LED
D8002	LNG401NPY	LED
D8003	LNG401NPY	LED
D8004	LNG101WHKA	LED
D8403	MA8330MTX	DIODE
D8404	MA8330MTX	DIODE
D8405	MA2X33800L	DIODE
D8406	MA2X33800L	DIODE
D8408	MA3X74800L	DIODE
D8410	LNJ208R8ARA	DIODE
D8411	MA3X152K0L	DIODE
D8412	MA3X152K0L	DIODE
D8413	MA3X152K0L	DIODE
D8414	MA3X15300L	DIODE
D8415	MA3X15300L	DIODE
D8416	MA3X15300L	DIODE
D8417	MAZ31100ML	DIODE, ZENER
D8418	MAZ31100ML	DIODE, ZENER
D8419	MAZ31100ML	DIODE, ZENER
D8420	MAZ31100ML	DIODE, ZENER
D8421	MAZ31100ML	DIODE, ZENER
D8422	MAZ31100ML	DIODE, ZENER

COMPLETE REPLACEMENT PARTS LIST

Model: TU-DST52F

Important Safety Notice: Components printed in **BOLD TYPE** have special characteristics important for safety. When replacing any of these components use only manufacturer's specified parts.

REF NO.	PART NO.	DESCRIPTION
D8423	MAZ31100ML	DIODE, ZENER
D8424	MAZ31100ML	DIODE, ZENER
D8425	MAZ31100ML	DIODE, ZENER
D8426	MAZ31100ML	DIODE, ZENER
D8427	MAZ31100ML	DIODE, ZENER
D8428	MAZ31100ML	DIODE, ZENER
D8429	MAZ31100ML	DIODE, ZENER
D8430	MAZ31100ML	DIODE, ZENER
D8431	MAZ31100ML	DIODE, ZENER
D8432	MAZ31100ML	DIODE, ZENER
D8433	MAZ31100ML	DIODE, ZENER
D8434	MAZ31100ML	DIODE, ZENER
D8435	MAZ31100ML	DIODE, ZENER
D8436	MAZ31100ML	DIODE, ZENER
D8437	MAZ31100ML	DIODE, ZENER
D8438	MAZ31100ML	DIODE, ZENER
D8439	GP1FA511TZ	DIODE, LED
D8440	MA8330MTX	DIODE
D8441	MA8330MTX	DIODE
D8442	MA2J72800L	DIODE
D9802	B0EBKT000003	DIODE
D9803	MAZ41500LF	DIODE, ZENER
D9804	MAZ40200HF	DIODE, ZENER
D9805	MA2C165001VT	DIODE
D9806	MA2C165001VT	DIODE
D9807	MA2C165001VT	DIODE
D9808	SF10SC3L4012	DIODE
D9809	AU01ZV0	DIODE
D9810	BOJANE000006	DIODE
D9812	AU01ZV0	DIODE
D9814	MAZ41500MF	DIODE, ZENER
D9815	MAZ41500MF	DIODE, ZENER
FUSES		
F9801	K5D632AD0002	FUSE, 6.3A/125V
INTEGRATED CIRCUITS		
IC8400	UPC3217GV-E1	INT CKT
IC8401	LMC6482IMX	INT CKT
IC8402	TVS2AA04	IC, DRAM
IC8403	C0ZBZ0000380	INT CKT
IC8404	C0DBCFCG00003	INT CKT
IC8405	C0DBFFFG00004	INT CKT
IC8406	C1AB00001724	INT CKT
IC8407	MN88432	INT CKT
IC8408	MAX221ECUE-T	INT CKT
IC8409	TPS3823-33DB	IC, WATCH DOG TIMER
IC8410	TVS2AA04	IC, DRAM
IC8411	STI7000AQA	INT CKT
IC8412	TVSA0495	INT CKT
IC8413	TVSA0494	INT CKT
IC8414	TVS2AA20	INT CKT
IC8415	24LC64T-I/SN	INT CKT

REF NO.	PART NO.	DESCRIPTION
IC8416	PCF8593T	INT CKT
IC8418	C0JBZZ000251	INT CKT
IC8419	TVSA0508	INT CKT
IC8420	TVSA0508	INT CKT
IC8421	C1AB00001726	INT CKT
IC8422	C1AB00001727	INT CKT
IC8425	CS4339-KSR	INT CKT
IC8427	C1AB00001164	INT CKT
IC8428	BA15218F-E2	INT CKT
IC8430	C1AB00001697	INT CKT
IC8431	AD8073JR-RL	INT CKT
IC8432	AN78L09M-E1	INT CKT
IC8433	TVSA0497	INT CKT
IC9801	PC123FY2	INT CKT
IC9802	C0DAEJC00003	INT CKT
IC9803	AN7705F-LB	INT CKT
IC9804	AN79L05	INT CKT
COILS		
L8001	ELESN220JA	COIL, PEAKING 22UH
L8002	ELESN220JA	COIL, PEAKING 22UH
L8400	EXCML20A390U	FILTER, EMI
L8401	EXCML20A390U	FILTER, EMI
L8402	EXCML20A390U	FILTER, EMI
L8403	EXCML20A390U	FILTER, EMI
L8404	EXCML20A390U	FILTER, EMI
L8405	EXCML20A390U	FILTER, EMI
L8406	ELJNAR82JF	CHIP INDUCTOR, .82UH
L8407	ELJFA4R7KF	CHIP INDUCTOR, 4.7UH
L8408	EXCML20A390U	FILTER, EMI
L8409	ELJNAR82JF	CHIP INDUCTOR, .82UH
L8410	ELJFA4R7KF	CHIP INDUCTOR, 4.7UH
L8411	EXCML20A390U	FILTER, EMI
L8412	J0JCC0000100	FILTER, BEAD CORE
L8413	EXCML20A390U	FILTER, EMI
L8414	J0JCC0000100	FILTER, BEAD CORE
L8415	J0JCC0000100	FILTER, BEAD CORE
L8416	J0JCC0000100	FILTER, BEAD CORE
L8417	J0JCC0000100	FILTER, BEAD CORE
L8418	J0JCC0000100	FILTER, BEAD CORE
L8419	EXCML20A390U	FILTER, EMI
L8420	J0JCC0000100	FILTER, BEAD CORE
L8421	J0JCC0000100	FILTER, BEAD CORE
L8422	J0JCC0000100	FILTER, BEAD CORE
L8423	J0JCC0000100	FILTER, BEAD CORE
L8424	J0JCC0000100	FILTER, BEAD CORE
L8425	J0JCC0000100	FILTER, BEAD CORE
L8426	J0JCC0000100	FILTER, BEAD CORE
L8427	ELJFA270JF	CHIP INDUCTOR, 27UH
L8428	ELJFA270JF	CHIP INDUCTOR, 27UH
L8429	EXCML20A390U	FILTER, EMI
L8430	ELJFA100JF	CHIP INDUCTOR

COMPLETE REPLACEMENT PARTS LIST

Model: TU-DST52F

Important Safety Notice: Components printed in **BOLD TYPE** have special characteristics important for safety. When replacing any of these components use only manufacturer's specified parts.

REF NO.	PART NO.	DESCRIPTION
L8431	J0JCC0000100	FILTER, BEAD CORE
L8432	ELJFA270JF	CHIP INDUCTOR, 27UH
L8433	ELJFA270JF	CHIP INDUCTOR, 27UH
L8434	ELJFA100JF	CHIP INDUCTOR
L8435	EXCML20A390U	FILTER, EMI
L8436	EXCML20A390U	FILTER, EMI
L8437	TSKA173	HI LOSS INDUCTOR
L8438	TSKA173	HI LOSS INDUCTOR
L8439	EXCML20A390U	FILTER, EMI
L8440	EXCML20A390U	FILTER, EMI
L8441	EXCML20A390U	FILTER, EMI
L8442	EXCML20A390U	FILTER, EMI
L8443	EXCELDR25V	FERRITE BEAD
L8444	EXCML20A390U	FILTER, EMI
L8445	EXCML20A390U	FILTER, EMI
L8446	ELB4C570	DELAY LINE
L8447	ELB4B580	DELAY LINE
L8448	ELB4B580	DELAY LINE
L8449	EXCML20A390U	FILTER, EMI
L8450	EXCML20A390U	FILTER, EMI
L8451	EXCML20A390U	FILTER, EMI
L8452	EXCML20A390U	FILTER, EMI
L8453	ELJFA6R8KF	CHIP INDUCTOR, 6.8UH
L8454	ELJFA6R8KF	CHIP INDUCTOR, 6.8UH
L8455	ELJFA6R8KF	CHIP INDUCTOR, 6.8UH
L8456	EXCML20A390U	FILTER, EMI
L8457	ELJPA1R0MF	CHIP INDUCTOR
L8459	ELKE470FA	NOISE FILTER
L8460	ELKE470FA	NOISE FILTER
L8461	ELKE470FA	NOISE FILTER
L8462	ELKE470FA	NOISE FILTER
L8467	EXC3BB221H	FILTER
L8468	EXC3BB221H	FILTER
L8469	EXC3BB221H	FILTER
L8470	EXC3BB221H	FILTER
L8471	EXC3BB221H	FILTER
L8472	EXC3BB221H	FILTER
L8473	EXC3BB221H	FILTER
L8474	EXC3BB221H	FILTER
L8475	EXC3BB221H	FILTER
L8476	EXC3BB221H	FILTER
L8477	EXC3BB221H	FILTER
L8478	ELB3S402E	DELAY LINE
L8479	ELB3S402E	DELAY LINE
L8480	EXCML20A390U	FILTER, EMI
L8481	EXCELDR25V	FERRITE BEAD
L8482	ELJNA2R2JF	CHIP INDUCTOR
L8483	ELJNA2R2JF	CHIP INDUCTOR
L8484	ELJNA2R2JF	CHIP INDUCTOR
L8485	EXCML20A390U	FILTER, EMI
L8486	EXCML20A390U	FILTER, EMI

REF NO.	PART NO.	DESCRIPTION
L8488	EXCML20A390U	FILTER, EMI
L8499	EXCML20A390U	FILTER, EMI
L8500	EXCML20A390U	FILTER, EMI
L8502	EXCML20A390U	FILTER, EMI
L8503	EXCML20A390U	FILTER, EMI
L8504	EXCML20A390U	FILTER, EMI
L8505	EXCML20A390U	FILTER, EMI
L8506	EXCML20A390U	FILTER, EMI
L8507	EXCML20A390U	FILTER, EMI
L8508	ELJPA100KF	CHIP INDUCTOR, 10UH
L8509	ELJPA100KF	CHIP INDUCTOR, 10UH
L8510	EXCML20A390U	FILTER, EMI
L9801	G0B650H00002	COIL
L9802	ELF15N010A	LINE FILTER
L9803	EXCELDR35V	FERRITE BEAD
L9804	EXCELDR35V	FERRITE BEAD
L9805	G0C681Z00001	COIL
L9808	ELC08D220E	CHOKE COIL, 22UH
L9809	ELC08D220E	CHOKE COIL, 22UH
L9810	ELC08D2R2E	CHOKE COIL, 2.2UH
TRANSISTORS		
Q8001	2SA564AQRSTA	TRANSISTOR
Q8002	2SA564AQRSTA	TRANSISTOR
Q8003	2SA564AQRSTA	TRANSISTOR
Q8004	2SC1685QRSTA	TRANSISTOR
Q8005	2SC1685QRSTA	TRANSISTOR
Q8400	NDS355AN	TRANSISTOR
Q8401	NDS355AN	TRANSISTOR
Q8402	NDS355AN	TRANSISTOR
Q8403	NDS355AN	TRANSISTOR
Q8404	2SD601ARTX	TRANSISTOR
Q8407	2SB709ARTX	TRANSISTOR
Q8408	2SB709ARTX	TRANSISTOR
Q8409	2SB709ARTX	TRANSISTOR
Q8410	2SD601ARTX	TRANSISTOR
Q8411	2SB709ARTX	TRANSISTOR
Q8412	2SB709ARTX	TRANSISTOR
Q8413	2SB709ARTX	TRANSISTOR
Q8419	NDS355AN	TRANSISTOR
Q8420	2SB709ARTX	TRANSISTOR
Q8421	2SD601ARTX	TRANSISTOR
Q8422	2SC2480TX	TRANSISTOR
Q9801	B1DEEQ000004	TRANSISTOR
Q9802	2SC13180R	TRANSISTOR
RESISTORS		
RM8001	PIC-37142TC5	RCVR, REMOTE CONTROL
R8001	ERDS2TJ103T	RES,C 10K-J-1/4W
R8002	ERDS2TJ680T	RES,C 68-J-1/4W
R8003	ERDS2TJ680T	RES,C 68-J-1/4W
R8004	ERDS2TJ680T	RES,C 68-J-1/4W
R8005	ERDS2TJ103T	RES,C 10K-J-1/4W

COMPLETE REPLACEMENT PARTS LIST

Model: TU-DST52F

Important Safety Notice: Components printed in **BOLD TYPE** have special characteristics important for safety. When replacing any of these components use only manufacturer's specified parts.

REF NO.	PART NO.	DESCRIPTION
R8006	ERDS2TJ103T	RES,C 10K-J-1/4W
R8007	ERDS2TJ103T	RES,C 10K-J-1/4W
R8008	ERDS2TJ122T	RES,C 1.2K-J-1/4W
R8009	ERDS2TJ102T	RES,C 1K-J-1/4W
R8010	ERDS2TJ102T	RES,C 1K-J-1/4W
R8012	ERDS2TJ271T	RES,C 270-J-1/4W
R8013	ERDS2TJ102T	RES,C 1K-J-1/4W
R8014	ERDS2TJ102T	RES,C 1K-J-1/4W
R8016	ERDS2TJ103T	RES,C 10K-J-1/4W
R8017	ERDS2TJ101T	RES,C 100-J-1/4W
R8018	ERDS2TJ101T	RES,C 100-J-1/4W
R8019	ERDS2TJ101T	RES,C 100-J-1/4W
R8020	ERDS2TJ101T	RES,C 100-J-1/4W
R8021	ERDS2TJ101T	RES,C 100-J-1/4W
R8022	ERDS2TJ101T	RES,C 100-J-1/4W
R8023	ERDS2TJ101T	RES,C 100-J-1/4W
R8024	ERDS2TJ101T	RES,C 100-J-1/4W
R8025	ERDS2TJ101T	RES,C 100-J-1/4W
R8026	ERDS2TJ101T	RES,C 100-J-1/4W
R8027	ERDS2TJ101T	RES,C 100-J-1/4W
R8028	ERDS2TJ101T	RES,C 100-J-1/4W
R8029	ERDS2TJ101T	RES,C 100-J-1/4W
R8030	ERDS2TJ101T	RES,C 100-J-1/4W
R8413	ERJ3GEYJ104V	RES,M 100K-J-1/32W
R8414	ERJ3GEYJ104V	RES,M 100K-J-1/32W
R8416	ERJ3GEYJ100V	RES,M 10-J-1/32W
R8417	ERJ3GEYJ123V	RES,M 12K-J-1/32W
R8418	ERJ3GEYJ103V	RES,M 10K-J-1/32W
R8419	ERJ3GEYJ200V	RES,M 20-J-1/32W
R8420	ERJ3GEYJ200V	RES,M 20-J-1/32W
R8422	ERJ3GEYJ103V	RES,M 10K-J-1/32W
R8423	ERJ3GEYJ103V	RES,M 10K-J-1/32W
R8431	ERJ3GEYJ104V	RES,M 100K-J-1/32W
R8433	ERJ3EKF1502V	RES,M 1.5K-F-1/16W
R8434	ERJ3EKF1002V	RES,M 1K-F-1/16W
R8435	ERJ3GEYJ104V	RES,M 100K-J-1/32W
R8436	ERJ6GEYJ473V	RES,M 47K-J-1/10W
R8440	ERJ6GEYJ4R7V	RES,M 4.7-J-1/10W
R8441	ERJ6GEYJ103V	RES,M 10K-J-1/10W
R8445	ERJ3GEYJ102V	RES,M 1K-J-1/32W
R8446	ERJ6GEYJ103V	RES,M 10K-J-1/10W
R8447	ERJ3GEYJ103V	RES,M 10K-J-1/32W
R8448	ERJ3GEYJ103V	RES,M 10K-J-1/32W
R8449	ERJ3GEYJ511V	RES,M 510-J-1/32W
R8450	ERJ3GEYJ103V	RES,M 10K-J-1/32W
R8451	ERJ6GEYJ103V	RES,M 10K-J-1/10W
R8452	ERJ3GEYJ103V	RES,M 10K-J-1/32W
R8453	ERJ3GEYJ511V	RES,M 510-J-1/32W
R8454	ERJ3GEYJ511V	RES,M 510-J-1/32W
R8455	ERJ3GEYJ102V	RES,M 1K-J-1/32W
R8456	ERJ3GEYJ102V	RES,M 1K-J-1/32W

REF NO.	PART NO.	DESCRIPTION
R8457	ERJ6GEYJ512V	RES,M 5.1K-J-1/10W
R8459	ERJ3GEYJ512V	RES,M 5.1K-J-1/32W
R8460	ERJ6GEYJ330V	RES,M 33-J-1/10W
R8461	ERJ3GEYJ222V	RES,M 2.2K-J-1/32W
R8462	ERJ6GEYJ222V	RES,M 2.2K-J-1/10W
R8463	ERJ3GEYJ222V	RES,M 2.2K-J-1/32W
R8464	ERJ3GEYJ222V	RES,M 2.2K-J-1/32W
R8465	ERJ3GEYJ222V	RES,M 2.2K-J-1/32W
R8466	ERJ6GEYJ103V	RES,M 10K-J-1/10W
R8469	ERJ6GEYJ101V	RES,M 100-J-1/10W
R8470	ERJ3GEYJ100V	RES,M 10-J-1/32W
R8471	ERJ3GEYJ103V	RES,M 10K-J-1/32W
R8472	ERJ3GEYJ222V	RES,M 2.2K-J-1/32W
R8473	ERJ6GEYJ103V	RES,M 10K-J-1/10W
R8474	ERJ3GEYJ103V	RES,M 10K-J-1/32W
R8475	ERJ6GEYJ103V	RES,M 10K-J-1/10W
R8477	ERJ3GEYJ220V	RES,M 22-J-1/32W
R8481	ERJ3GEYJ103V	RES,M 10K-J-1/32W
R8482	ERJ6GEYJ240V	RES,M 24-J-1/10W
R8484	ERJ6GEYJ240V	RES,M 24-J-1/10W
R8485	EXB38V100JV	CHIP RESISTOR
R8490	ERJ6GEYJ103V	RES,M 10K-J-1/10W
R8492	EXB38V100JV	CHIP RESISTOR
R8493	ERJ3GEYJ103V	RES,M 10K-J-1/32W
R8494	EXB38V100JV	CHIP RESISTOR
R8496	ERJ6GEYJ470V	RES,M 47-J-1/10W
R8497	ERJ3GEYJ470V	RES,M 47-J-1/32W
R8498	ERJ3GEYJ470V	RES,M 47-J-1/32W
R8499	ERJ3GEYJ470V	RES,M 47-J-1/32W
R8500	EXB38V220JV	CHIP RESISTOR
R8502	EXB38V220JV	CHIP RESISTOR
R8503	EXB38V220JV	CHIP RESISTOR
R8504	EXB38V220JV	CHIP RESISTOR
R8507	EXB38V220JV	CHIP RESISTOR
R8508	EXB38V220JV	CHIP RESISTOR
R8509	EXB38V220JV	CHIP RESISTOR
R8510	EXB38V220JV	CHIP RESISTOR
R8511	ERJ3GEYJ220V	RES,M 22-J-1/32W
R8514	ERJ3GEYJ103V	RES,M 10K-J-1/32W
R8515	EXB38V220JV	CHIP RESISTOR
R8516	ERJ3GEYJ560V	RES,M 56-J-1/32W
R8517	ERJ3GEYJ560V	RES,M 56-J-1/32W
R8518	ERJ6GEYJ103V	RES,M 10K-J-1/10W
R8519	ERJ3GEYJ102V	RES,M 1K-J-1/32W
R8520	ERJ6GEYJ274V	RES,M 270K-J-1/10W
R8522	EXB38V620JV	RESISTOR NETWORK
R8523	ERJ6GEYJ330V	RES,M 33-J-1/10W
R8525	ERJ6GEYJ330V	RES,M 33-J-1/10W
R8527	ERJ6GEYJ474V	RES,M 470K-J-1/10W
R8528	ERJ6GEYJ474V	RES,M 470K-J-1/10W
R8529	ERJ6GEYJ105V	RES,M 1M-J-1/10W

COMPLETE REPLACEMENT PARTS LIST

Model: TU-DST52F

Important Safety Notice: Components printed in **BOLD TYPE** have special characteristics important for safety. When replacing any of these components use only manufacturer's specified parts.

REF NO.	PART NO.	DESCRIPTION
R8530	ERJ6GEYJ331V	RES,M 330-J-1/10W
R8531	ERJ3GEYJ102V	RES,M 1K-J-1/32W
R8532	ERJ3GEYJ102V	RES,M 1K-J-1/32W
R8533	ERJ6GEYJ103V	RES,M 10K-J-1/10W
R8534	ERJ6GEYJ103V	RES,M 10K-J-1/10W
R8535	ERJ6GEYJ103V	RES,M 10K-J-1/10W
R8536	ERJ6GEYJ330V	RES,M 33-J-1/10W
R8537	ERJ3GEYJ103V	RES,M 10K-J-1/32W
R8538	ERJ6GEYJ103V	RES,M 10K-J-1/10W
R8539	EXB38V120JV	RESISTOR NETWORK
R8540	EXB38V620JV	RESISTOR NETWORK
R8541	EXB38V120JV	RESISTOR NETWORK
R8543	EXB38V620JV	RESISTOR NETWORK
R8544	EXB38V120JV	RESISTOR NETWORK
R8545	EXB38V620JV	RESISTOR NETWORK
R8546	EXB38V620JV	RESISTOR NETWORK
R8547	EXB38V620JV	RESISTOR NETWORK
R8548	EXB38V120JV	RESISTOR NETWORK
R8549	EXB38V620JV	RESISTOR NETWORK
R8551	ERJ6GEYJ242V	RES,M 2.4K-J-1/10W
R8553	EXB38V620JV	RESISTOR NETWORK
R8554	ERJ6GEYJ242V	RES,M 2.4K-J-1/10W
R8555	EXB38V120JV	RESISTOR NETWORK
R8556	ERJ6GEYJ4R7V	RES,M 4.7-J-1/10W
R8557	EXB38V620JV	RESISTOR NETWORK
R8558	EXB38V620JV	RESISTOR NETWORK
R8559	EXB38V620JV	RESISTOR NETWORK
R8560	EXB38V620JV	RESISTOR NETWORK
R8561	EXB38V620JV	RESISTOR NETWORK
R8562	EXB38V620JV	RESISTOR NETWORK
R8563	EXB38V620JV	RESISTOR NETWORK
R8564	EXB38V620JV	RESISTOR NETWORK
R8565	EXB38V620JV	RESISTOR NETWORK
R8566	ERJ6GEYJ103V	RES,M 10K-J-1/10W
R8568	ERJ6GEYJ103V	RES,M 10K-J-1/10W
R8569	ERJ6GEYJ103V	RES,M 10K-J-1/10W
R8570	ERJ3GEYJ201V	RES,M 200-J-1/32W
R8571	ERJ3GEYJ151V	RES,M 150-J-1/32W
R8574	ERJ6GEYJ103V	RES,M 10K-J-1/10W
R8576	ERJ6GEYJ392V	RES,M 3.9K-J-1/10W
R8577	ERJ3GEYJ103V	RES,M 10K-J-1/32W
R8579	ERJ6GEYJ103V	RES,M 10K-J-1/10W
R8580	EXB38V122JV	RESISTOR NETWORK
R8581	EXB38V102JV	RESISTOR NETWORK
R8582	EXB38V122JV	RESISTOR NETWORK
R8583	EXB38V102JV	RESISTOR NETWORK
R8588	EXB38V122JV	RESISTOR NETWORK
R8589	EXB38V102JV	RESISTOR NETWORK
R8590	EXB38V122JV	RESISTOR NETWORK
R8591	EXB38V102JV	RESISTOR NETWORK
R8592	ERJ3GEYJ122V	RES,M 1.2K-J-1/32W

REF NO.	PART NO.	DESCRIPTION
R8593	ERJ3GEYJ102V	RES,M 1K-J-1/32W
R8596	ERJ6GEYJ103V	RES,M 10K-J-1/10W
R8597	ERJ6GEYJ103V	RES,M 10K-J-1/10W
R8598	ERJ6GEYJ103V	RES,M 10K-J-1/10W
R8599	ERJ6GEYJ103V	RES,M 10K-J-1/10W
R8600	ERJ6ENF3010V	RES,M 301-F-1/10W
R8602	ERJ6GEYJ103V	RES,M 10K-J-1/10W
R8603	ERJ6ENF3010V	RES,M 301-F-1/10W
R8607	ERJ3GEYJ103V	RES,M 10K-J-1/32W
R8610	ERJ6GEYJ103V	RES,M 10K-J-1/10W
R8611	ERJ6ENF2051V	RES,M 2.05K-F-1/10W
R8612	ERJ6ENF2491V	RES,M 2.49K-F-1/10W
R8631	ERJ6ENF1820V	RES,M 182-F-1/10W
R8632	ERJ6ENF1820V	RES,M 182-F-1/10W
R8633	ERJ6ENF1820V	RES,M 182-F-1/10W
R8634	ERJ3GEYJ102V	RES,M 1K-J-1/32W
R8635	ERJ6GEYJ223V	RES,M 22K-J-1/10W
R8636	ERJ6GEYJ332V	RES,M 3.3K-J-1/10W
R8637	ERJ6GEYJ332V	RES,M 3.3K-J-1/10W
R8638	ERJ6GEYJ332V	RES,M 3.3K-J-1/10W
R8639	ERJ6GEYJ471V	RES,M 470-J-1/10W
R8640	ERJ3GEYJ471V	RES,M 470-J-1/32W
R8641	ERJ3GEYJ471V	RES,M 470-J-1/32W
R8642	ERJ3GEYJ471V	RES,M 470-J-1/32W
R8649	ERJ6GEYJ102V	RES,M 1K-J-1/10W
R8650	ERJ6GEYJ102V	RES,M 1K-J-1/10W
R8651	ERJ6GEYJ102V	RES,M 1K-J-1/10W
R8652	ERJ3GEYJ681V	RES,M 680-J-1/32W
R8653	ERJ3GEYJ681V	RES,M 680-J-1/32W
R8654	ERJ3GEYJ681V	RES,M 680-J-1/32W
R8655	ERJ6ENF6800V	RES,M 680-F-1/10W
R8656	ERJ6ENF6800V	RES,M 680-F-1/10W
R8657	ERJ6ENF6800V	RES,M 680-F-1/10W
R8671	ERJ6GEYJ155V	RES,M 1.5MEG-J-1/10W
R8672	ERJ6GEYJ473V	RES,M 47K-J-1/10W
R8675	ERJ6GEYJ155V	RES,M 1.5MEG-J-1/10W
R8676	ERJ6GEYJ473V	RES,M 47K-J-1/10W
R8677	ERJ6GEYJ155V	RES,M 1.5MEG-J-1/10W
R8678	ERJ6GEYJ473V	RES,M 47K-J-1/10W
R8683	ERJ6GEYJ103V	RES,M 10K-J-1/10W
R8687	ERJ6GEYJ103V	RES,M 10K-J-1/10W
R8688	ERJ6GEYJ103V	RES,M 10K-J-1/10W
R8690	ERJ3GEYJ472V	RES,M 4.7K-J-1/32W
R8691	ERJ3GEYJ472V	RES,M 4.7K-J-1/32W
R8695	ERJ3GEYJ562V	RES,M 5.6K-J-1/32W
R8696	ERJ3GEYJ392V	RES,M 2.9K-J-1/32W
R8697	ERJ3GEYJ562V	RES,M 5.6K-J-1/32W
R8698	ERJ3GEYJ392V	RES,M 2.9K-J-1/32W
R8701	ERJ3GEYJ101V	RES,M 100-J-1/32W
R8702	ERJ3GEYJ101V	RES,M 100-J-1/32W
R8705	ERJ6ENF75R0V	RES,M 75.0-F-1/10W

COMPLETE REPLACEMENT PARTS LIST

Model: TU-DST52F

Important Safety Notice: Components printed in **BOLD TYPE** have special characteristics important for safety. When replacing any of these components use only manufacturer's specified parts.

REF NO.	PART NO.	DESCRIPTION
R8706	ERJ6ENF75R0V	RES,M 75.0-F-1/10W
R8707	ERJ6ENF75R0V	RES,M 75.0-F-1/10W
R8708	ERJ6ENF75R0V	RES,M 75.0-F-1/10W
R8709	ERJ6ENF75R0V	RES,M 75.0-F-1/10W
R8710	ERJ3GEYJ821V	RES,M 820-J-1/32W
R8711	ERJ3GEYJ821V	RES,M 820-J-1/32W
R8712	ERJ3GEYJ821V	RES,M 820-J-1/32W
R8713	ERJ3GEYJ821V	RES,M 820-J-1/32W
R8714	ERJ6ENF75R0V	RES,M 75.0-F-1/10W
R8715	ERJ6ENF75R0V	RES,M 75.0-F-1/10W
R8724	ERJ3GEYJ103V	RES,M 10K-J-1/32W
R8725	ERJ3GEYJ103V	RES,M 10K-J-1/32W
R8726	EXB38V120JV	RESISTOR NETWORK
R8727	EXB38V120JV	RESISTOR NETWORK
R8728	EXB38V120JV	RESISTOR NETWORK
R8729	EXB38V120JV	RESISTOR NETWORK
R8730	EXB38V120JV	RESISTOR NETWORK
R8731	EXB38V120JV	RESISTOR NETWORK
R8734	ERJ6GEYJ103V	RES,M 10K-J-1/10W
R8737	ERJ6GEYJ330V	RES,M 33-J-1/10W
R8738	ERJ6ENF75R0V	RES,M 75.0-F-1/10W
R8740	ERJ6GEYJ103V	RES,M 10K-J-1/10W
R8741	ERJ6ENF75R0V	RES,M 75.0-F-1/10W
R8742	ERJ6ENF75R0V	RES,M 75.0-F-1/10W
R8747	ERJ6ENF75R0V	RES,M 75.0-F-1/10W
R8748	ERJ6ENF75R0V	RES,M 75.0-F-1/10W
R8749	ERJ6ENF75R0V	RES,M 75.0-F-1/10W
R8750	ERJ3GEYJ221V	RES,M 220-J-1/32W
R8751	ERJ3GEYJ221V	RES,M 220-J-1/32W
R8752	ERJ3GEYJ221V	RES,M 220-J-1/32W
R8753	ERJ3GEYJ103V	RES,M 10K-J-1/32W
R8759	ERJ6GEYJ103V	RES,M 10K-J-1/10W
R8761	ERJ3GEYJ103V	RES,M 10K-J-1/32W
R8766	ERJ3GEYJ223V	RES,M 22K-J-1/32W
R8767	ERJ3GEYJ153V	RES,M 15K-F-1/32W
R8768	ERJ3GEYJ163V	RES,M 16K-F-1/32W
R8769	ERJ3GEYJ113V	RES,M 11K-J-1/32W
R8770	ERJ3GEYJ511V	RES,M 510-J-1/32W
R8772	ERJ3EKF2491V	RES,M 2.49K-F-1/32W
R8781	ERJ6ENF37R4V	RES,M 37.4-F-1/10W
R8782	ERJ6ENF37R4V	RES,M 37.4-F-1/10W
R8783	ERJ6ENF37R4V	RES,M 37.4-F-1/10W
R8785	ERJ6ENF4120V	RES,M 412-F-1/10W
R8786	ERJ6ENF6800V	RES,M 680-F-1/10W
R8789	ERJ6ENF6800V	RES,M 680-F-1/10W
R8790	ERJ6ENF6800V	RES,M 680-F-1/10W
R8791	ERJ6ENF4120V	RES,M 412-F-1/10W
R8793	ERJ6ENF4120V	RES,M 412-F-1/10W
R8796	ERJ6GEYJ124V	RES,M 120K-J-1/10W
R8797	ERJ6GEYJ104V	RES,M 100K-J-1/10W
R8798	ERJ6GEYJ104V	RES,M 100K-J-1/10W

REF NO.	PART NO.	DESCRIPTION
R8800	ERJ6ENF37R4V	RES,M 37.4-F-1/10W
R8801	ERJ6ENF37R4V	RES,M 37.4-F-1/10W
R8802	ERJ6ENF37R4V	RES,M 37.4-F-1/10W
R8803	ERJ6GEYJ103V	RES,M 10K-J-1/10W
R8804	ERJ6GEYJ104V	RES,M 100K-J-1/10W
R8806	ERJ6GEYJ103V	RES,M 10K-J-1/10W
R8813	ERJ3EKF37R4V	RES,M 37.4-F-1/10W
R8814	ERJ3EKF37R4V	RES,M 37.4-F-1/10W
R8815	ERJ3EKF37R4V	RES,M 37.4-F-1/10W
R8818	ERJ3GEYJ103V	RES,M 10K-J-1/32W
R8820	ERJ3GEYJ202V	RES,M 2K-J-1/32W
R8821	ERJ6GEYJ103V	RES,M 10K-J-1/10W
R8822	ERJ3GEYJ103V	RES,M 10K-J-1/32W
R8823	ERJ6GEYJ102V	RES,M 1K-J-1/10W
R8825	ERJ3GEYJ102V	RES,M 1K-J-1/32W
R9801	ERD75TAJ825	RES,C 8.2MEG-J-3/4W
R9802	ERF2AKR68P	RES,W .68-K-2W
R9803	ERDS2TJ104T	RES,C 100K-J-1/4W
R9804	ERDS2TJ104T	RES,C 100K-J-1/4W
R9805	ERDS2TJ223T	RES,C 22K-J-1/4W
R9806	ERDS2TJ333T	RES,C 33K-J-1/4W
R9807	ERG2FJ331H	RES,M 330-J-2W
R9808	ERDS2TJ681T	RES,C 680-J-1/4W
R9809	ERDS2TJ821T	RES,C 820-J-1/4W
R9810	ERDS2TJ331T	RES,C 330-J-1/4W
R9812	ERDS2TJ101T	RES,C 100-J-1/4W
R9813	ERDS2TJ222T	RES,C 2.2K-J-1/4W
R9814	ERDS2TJ101T	RES,C 100-J-1/4W
R9815	ERG2FJ681H	RES,M 680-J-2W
R9816	ERDS2TJ101T	RES,C 10-J-1/4W
R9817	ER0S2THF2701	RES,M 2.7K-F-1/4W
R9818	ER0S2THF56R0	RES,M 56-F-1/4W
R9819	ER0S2THF8200	RES,M 820-F-1/4
SWITCHES		
S8001	EVQ23407K	SWITCH
S8003	EVQ23407K	SWITCH
S8004	EVQ23407K	SWITCH
S8005	EVQ23407K	SWITCH
S8006	EVQ23407K	SWITCH
S8007	EVQ23407K	SWITCH
S8008	EVQ23407K	SWITCH
S8009	EVQ23407K	SWITCH
S8010	EVQ23407K	SWITCH
TRANSFORMERS		
T9801	ETS28AU1Z5AD	TRANSFORMER
CRYSTALS & FILTERS		
X8301	H0D400400019	CRYSTAL
X8302	H0A327600001	CRYSTAL, 327 MHZ
X8309	H0J270500018	CRYSTAL
X8320	H0J493500003	CRYSTAL
X9000	J0C4405A0001	CRYSTAL

COMPLETE REPLACEMENT PARTS LIST

Model: TU-DST52F

Important Safety Notice: Components printed in **BOLD TYPE** have special characteristics important for safety. When replacing any of these components use only manufacturer's specified parts.

REF NO.	PART NO.	DESCRIPTION
X9001	J0C4405A0002	CRYSTAL
OTHERS		
TNR8400	ENV56E28D5	TUNER
M001	TSX2AA0261	LINE CORD, AC
M002	TJS2AW0011	RECEPTACLE, AC
M003	TUA2AA0034	BOTTOM CHASSIS
M004	TKP2AA0771	MODE LED PANEL
M005	TBXA19603A	BUTTONS
M006	TKF2AA00103	TOP COVER
M007	TKP2AA0494S	FRONT PANEL
M008	TKP2AA0501	LED PANEL

REF NO.	PART NO.	DESCRIPTION
M009	TKX2AA0111	IR GUIDE
JK8304	TJB2AA0431	TERMINAL, A/V
M010	TJS2AX0081	TERMINAL, S-VHS
JK9701	K2HC103J0010	DATA IN CONNECTOR
ACCESSORIES		
M011	EUR7613Z50	REMOTE CONTROL
M012	UR76EC0303A	BATTERY COVER, REMOTE CONTROL
M013	TQB2AA0446	MANUAL, OWNERS

DESCRIPTION OF ABBREVIATIONS GUIDE

RESISTOR			
TYPE		TOLERANCE	
C	Carbon	F	+/- 1%
F	Fuse	J	+/- 5%
M	Metal Oxide	K	+/- 10%
S	Solid	M	+/- 20%
W	Wire Wound	G	+/- 2%

RES, C 270-J-1/4

CAPACITOR			
TYPE		TOLERANCE	
C	Ceramic	C	+/- 0.25pF
E	Electrolytic	D	+/- 0.5pF
P	Polyester	F	+/- 1pF
S	Styrol	J	+/- 5%
T	Tantalum	K	+/- 10%
		L	+/- 15%
		M	+/- 20%
		P	+10% -0%
		Z	+80% -20%

CAP, P .068UF-K-50V

Panasonic®

**PRINTED IN USA
K02110050PL1128**