

Operator's Manual

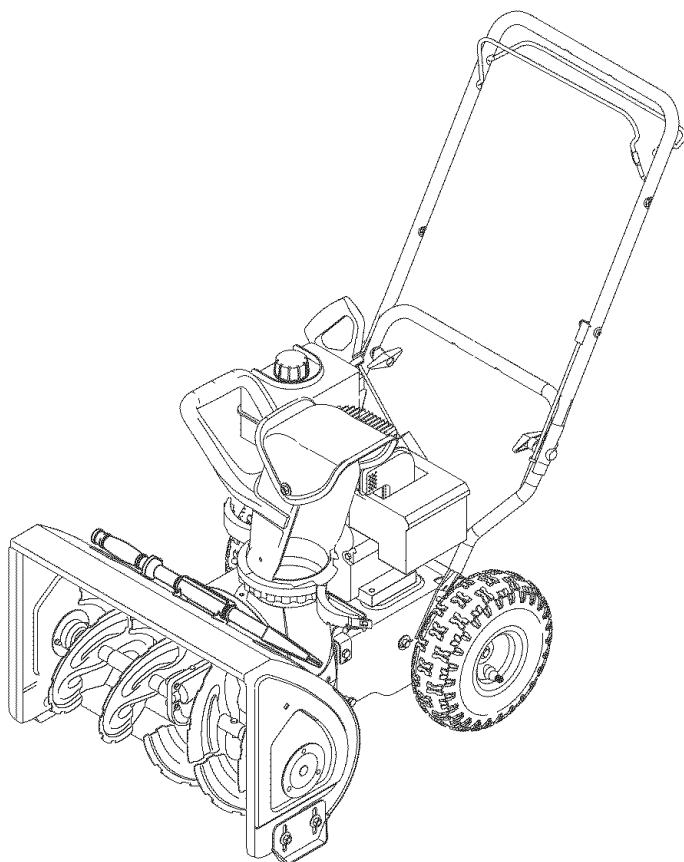

Two-Stage Snow Thrower Model 3BA

IMPORTANT: Read safety rules and instructions carefully before operating equipment.

Warning: This unit is equipped with an internal combustion engine and should not be used on or near any unimproved forest-covered, brush-covered or grass-covered land unless the engine's exhaust system is equipped with a spark arrester meeting applicable local or state laws (if any). If a spark arrester is used, it should be maintained in effective working order by the operator. In the State of California the above is required by law (Section 4442 of the California Public Resources Code). Other states may have similar laws. Federal laws apply on federal lands. A spark arrester for the muffler is available through your nearest engine authorized service dealer or contact the service department, P.O. Box 361131 Cleveland, Ohio 44136-0019.

MTD LLC, P.O. BOX 361131 CLEVELAND, OHIO 44136-0019

PRINTED IN U.S.A.

FORM NO. 769-00747B
(5/2004)

TABLE OF CONTENTS

Content	Page	Content	Page
Important Safe Operation Practices	3	Maintaining Your Snow Thrower	11
Assembling Your Snow Thrower	5	Servicing Your Snow Thrower	12
Know Your Snow Thrower	7	Trouble Shooting	14
Operating Your Snow Thrower	8	Illustrated Parts	15
Making Adjustments	10	Warranty	20

FINDING MODEL NUMBER

This Operator's Manual is an important part of your new snow thrower. It will help you assemble, prepare and maintain the unit for best performance. Please read and understand what it says.



Before you start assembling your new equipment, please locate the model plate on the equipment and copy the information from it in the space provided below. A sample model plate is also given below. You can locate the model plate by standing at the operating position and looking down at the rear of the snow thrower. This information will be necessary to use the manufacturer's web site and/or help from the Customer Support Department or an authorized service dealer.



Copy the model number here: _____

Copy the serial number here: _____

CUSTOMER SUPPORT

Please do NOT return the unit to the retailer from where it was purchased, without first contacting Customer Support.

If you have difficulty assembling this product or have any questions regarding the controls, operation or maintenance of this unit, you can seek help from the experts. Choose from the options below:

	<p>Visit mtdproducts.com for many useful suggestions. Click on Customer Support button and you will get the four options reproduced here. Click on the appropriate button and help is immediately available.</p> <div style="display: flex; justify-content: space-between; align-items: center; margin-top: 20px;"> <div style="width: 45%; text-align: center;"> <p><i>The answer you are looking for could be just a mouse click away!</i></p> </div> <div style="width: 30%; border: 1px solid black; padding: 5px;"> <div style="border-bottom: 1px solid black; padding: 2px;"> <p>Find Answers Click here to search our knowledge base. Search by product, keyword, or phrase.</p> </div> <div style="border-bottom: 1px solid black; padding: 2px;"> <p>My Stuff Login to check the status of your questions, modify your inquiries, or update your personal profile.</p> </div> <div style="border-bottom: 1px solid black; padding: 2px;"> <p>Service Locator Need local assistance? Click here to find authorized service centers in your area.</p> </div> <div style="padding: 2px;"> <p>Manuals Online Need a manual and/or parts list? Download literature from recent model years.</p> </div> </div> <div style="width: 45%; text-align: center;"> <p><i>The answer you are looking for could be just a mouse click away!</i></p> </div> </div>
	<p>If you prefer to reach a Customer Support Representative, please call 1-800-800-7310.</p>
	<p>The engine manufacturer is responsible for all engine-related issues with regards to performance, power-rating, specifications, warranty and service. Please refer to the engine manufacturer's Owner's/Operator's Manual, packed separately with your unit, for more information.</p>

SECTION 1: IMPORTANT SAFE OPERATION PRACTICES



WARNING: This symbol points out important safety instructions which, if not followed, could endanger the personal safety and/or property of yourself and others. Read and follow all instructions in this manual before attempting to operate this machine. Failure to comply with these instructions may result in personal injury. When you see this symbol—**heed its warning.**



WARNING: Engine Exhaust, some of its constituents, and certain vehicle components contain or emit chemicals known to State of California to cause cancer and birth defects or other reproductive harm.

DANGER: This machine was built to be operated according to the rules for safe operation in this manual. As with any type of power equipment, carelessness or error on the part of the operator can result in serious injury. This machine is capable of amputating hands and feet and throwing objects. Failure to observe the following safety instructions could result in serious injury or death.

Training

1. Read, understand, and follow all instructions on the machine and in the manual(s) before attempting to assemble and operate. Keep this manual in a safe place for future and regular reference and for ordering replacement parts.
 2. Be familiar with all controls and their proper operation. Know how to stop the machine and disengage them quickly.
 3. Never allow children under 14 years old to operate this machine. Children 14 years old and over should read and understand the operation instructions and safety rules in this manual and should be trained and supervised by a parent.
 4. Never allow adults to operate this machine without proper instruction.
 5. Thrown objects can cause serious personal injury. Plan your snow-throwing pattern to avoid discharge of material toward roads, bystanders and the like.
 6. Keep bystanders, helpers, pets and children at least 75 feet from the machine while it is in operation. Stop machine if anyone enters the area.
 7. Exercise caution to avoid slipping or falling, especially when operating in reverse.
7. Never attempt to make any adjustments while engine is running, except where specifically recommended in the operator's manual.
 8. Let engine and machine adjust to outdoor temperature before starting to clear snow.
 9. To avoid personal injury or property damage use extreme care in handling gasoline. Gasoline is extremely flammable and the vapors are explosive. Serious personal injury can occur when gasoline is spilled on yourself or your clothes, which can ignite. Wash your skin and change clothes immediately.
 - a. Use only an approved gasoline container.
 - b. Extinguish all cigarettes, cigars, pipes and other sources of ignition.
 - c. Never fuel machine indoors.
 - d. Never remove gas cap or add fuel while the engine is hot or running.
 - e. Allow engine to cool at least two minutes before refueling.
 - f. Never over fill fuel tank. Fill tank to no more than ½ inch below bottom of filler neck to provide space for fuel expansion.
 - g. Replace gasoline cap and tighten securely.
 - h. If gasoline is spilled, wipe it off the engine and equipment. Move machine to another area. Wait 5 minutes before starting the engine.
 - i. Never store the machine or fuel container inside where there is an open flame, spark or pilot light (e.g. furnace, water heater, space heater, clothes dryer etc.).
 - j. Allow machine to cool at least 5 minutes before storing.

Preparation

1. Thoroughly inspect the area where the equipment is to be used. Remove all doormats, newspapers, sleds, boards, wires and other foreign objects, which could be tripped over or thrown by the auger/impeller.
2. Always wear safety glasses or eye shields during operation and while performing an adjustment or repair to protect your eyes. Thrown objects which ricochet can cause serious injury to the eyes.
3. Do not operate without wearing adequate winter outer garments. Do not wear jewelry, long scarves or other loose clothing, which could become entangled in moving parts. Wear footwear which will improve footing on slippery surfaces.
4. Use a grounded three-wire extension cord and receptacle for all units with electric start engines.
5. Adjust collector housing height to clear gravel or crushed rock surfaces.
6. Disengage all control levers before starting the engine.

Operation

1. Do not put hands or feet near rotating parts, in the auger/impeller housing or chute assembly. Contact with the rotating parts can amputate hands and feet.
2. The auger/impeller control lever is a safety device. Never bypass its operation. Doing so makes the machine unsafe and may cause personal injury.
3. The control levers must operate easily in both directions and automatically return to the disengaged position when released.
4. Never operate with a missing or damaged chute assembly. Keep all safety devices in place and working.

5. Never run an engine indoors or in a poorly ventilated area. Engine exhaust contains carbon monoxide, an odorless and deadly gas.
 6. Do not operate machine while under the influence of alcohol or drugs.
 7. Muffler and engine become hot and can cause a burn. Do not touch.
 8. Exercise extreme caution when operating on or crossing gravel surfaces. Stay alert for hidden hazards or traffic.
 9. Exercise caution when changing direction and while operating on slopes.
 10. Plan your snow-throwing pattern to avoid discharge towards windows, walls, cars etc. Thus, avoiding possible property damage or personal injury caused by a ricochet.
 11. Never direct discharge at children, bystanders and pets or allow anyone in front of the machine.
 12. Do not overload machine capacity by attempting to clear snow at too fast of a rate.
 13. Never operate this machine without good visibility or light. Always be sure of your footing and keep a firm hold on the handles. Walk, never run.
 14. Disengage power to the auger/impeller when transporting or not in use.
 15. Never operate machine at high transport speeds on slippery surfaces. Look down and behind and use care when backing up.
 16. If the machine should start to vibrate abnormally, stop the engine, disconnect the spark plug wire and ground it against the engine. Inspect thoroughly for damage. Repair any damage before starting and operating.
 17. Disengage all control levers and stop engine before you leave the operating position (behind the handles). Wait until the auger/impeller comes to a complete stop before unclogging the chute assembly, making any adjustments, or inspections.
 18. Never put your hand in the discharge or collector openings. Always use the clean-out tool provided to unclog the discharge opening. Do not unclog chute assembly while engine is running. Shut off engine and remain behind handles until all moving parts have stopped before unclogging.
 19. Use only attachments and accessories approved by the manufacturer (e.g. wheel weights, tire chains, cabs etc.).
 20. If situations occur which are not covered in this manual, use care and good judgment. Contact your dealer or call 1-800-800-7310 for assistance and the name of your nearest servicing dealer.
2. Before cleaning, repairing, or inspecting machine disengage all control levers and stop the engine. Wait until the auger/impeller come to a complete stop. Disconnect the spark plug wire and ground against the engine to prevent unintended starting.
 3. Check bolts and screws for proper tightness at frequent intervals to keep the machine in safe working condition. Also, visually inspect machine for any damage.
 4. Do not change the engine governor setting or over-speed the engine. The governor controls the maximum safe operating speed of the engine.
 5. Snow thrower shave plates and skid shoes are subject to wear and damage. For your safety protection, frequently check all components and replace with original equipment manufacturer's (OEM) parts only. "Use of parts which do not meet the original equipment specifications may lead to improper performance and compromise safety!"
 6. Check controls periodically to verify they engage and disengage properly and adjust, if necessary. Refer to the adjustment section in this operator's manual for instructions.
 7. Maintain or replace safety and instruction labels, as necessary.
 8. Observe proper disposal laws and regulations for gas, oil, etc. to protect the environment.
 9. Prior to storing, run machine a few minutes to clear snow from machine and prevent freeze up of auger/impeller.
 10. Never store the machine or fuel container inside where there is an open flame, spark or pilot light such as a water heater, furnace, clothes dryer etc.
 11. Always refer to the operator's manual for proper instructions on off-season storage.

Maintenance & Storage

1. Never tamper with safety devices. Check their proper operation regularly. Refer to the maintenance and adjustment sections of this manual.

Your Responsibility

Restrict the use of this power machine to persons who read, understand and follow the warnings and instructions in this manual and on the machine.

Do not modify engine

To avoid serious injury or death, do not modify engine in any way. Tampering with the governor setting can lead to a runaway engine and cause it to operate at unsafe speeds. Never tamper with factory setting of engine governor.

Notice regarding Emissions

Engines which are certified to comply with California and federal EPA emission regulations for SORE (Small Off Road Equipment) are certified to operate on regular unleaded gasoline, and may include the following emission control systems: Engine Modification (EM) and Three Way Catalyst (TWC) if so equipped.

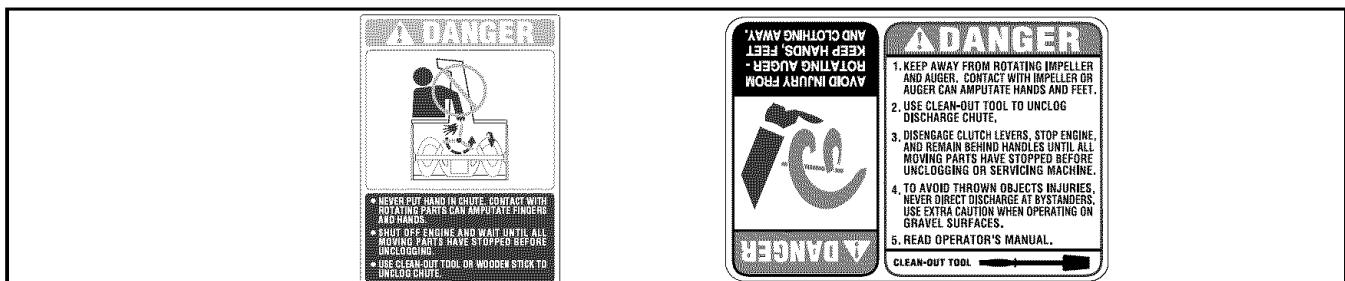

SECTION 2: ASSEMBLING YOUR SNOW THROWER

IMPORTANT: This unit is shipped with the engine full of oil. After assembly, see page 8 for fuel and oil details.

Removing From Carton

- Cut the corners of the carton and lay the sides flat on the ground. Remove all packing inserts.
- Move the snow thrower out of the carton.
- Make certain the carton has been completely emptied before discarding it.

Before Assembly

NOTE: Reference to right, left, front or rear of the unit is from the operating position unless otherwise stated.

- Cut the cable tie that secures the upper handle to the chute assembly for shipping purposes.

Setting Up The Handle

- Loosen the hand knob on the upper chute and pivot the upper chute upwards as far as it will go. Follow the direction of the arrow in Figure 1.

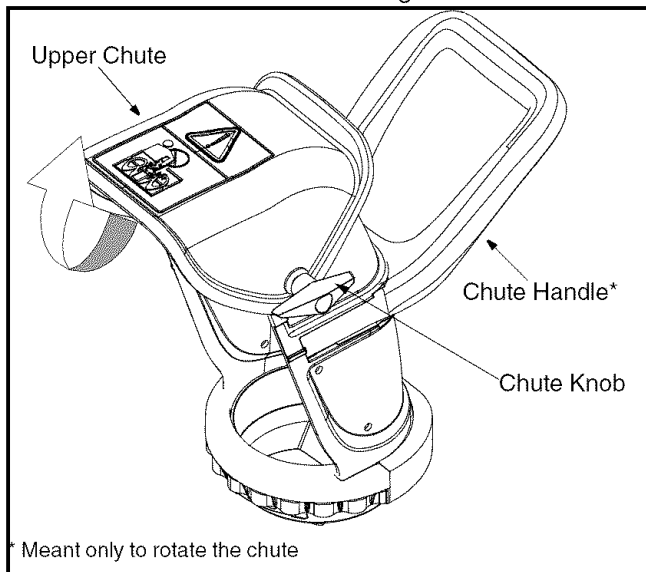

Figure 1



WARNING: Do not lift the snow thrower by the chute handle.

- Loosen the handle knob, saddle washer and handle tab on each side of the handle. See Figure 2.

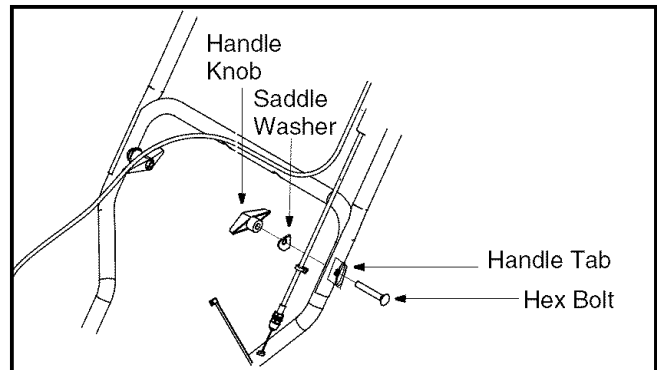

Figure 2

- Hold both controls against the upper handle and pull up as shown in Figure 3. Make sure that the upper handle locks over the lower handle and the handle tabs align with the handle. You may have to carefully maneuver the upper handle to clear the chute assembly.

CAUTION: Be careful not to bend or kink the cables.

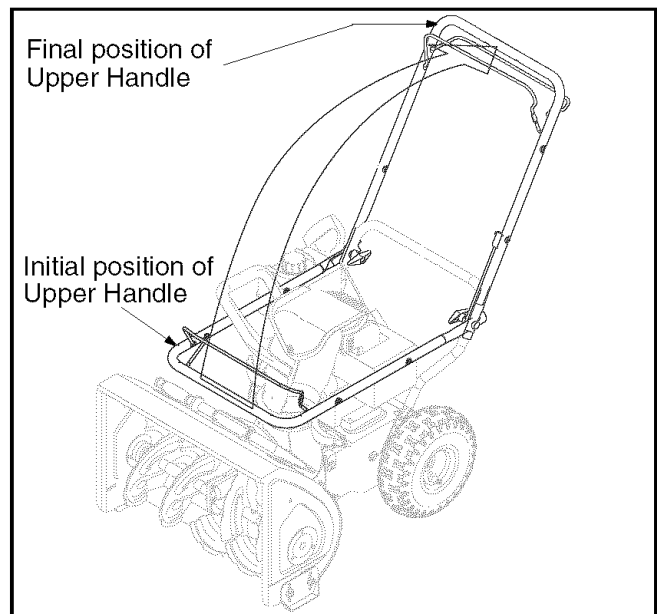

Figure 3

- Tighten the handle knobs on each side of the handle. Refer to Figure 2.
- Rotate the chute by the chute handle to the desired operating position.
- Tighten the chute knob on the upper chute making sure the flat washer and the carriage bolt are correctly positioned. Refer to Figure 1.

Clean-Out Tool

This tool and the electric extension cord, if so equipped, may be fastened with a cable tie to the rear of the auger housing for shipping purposes. In that case, cut the cable tie and remove the extension cord now.

Final Adjustments

IMPORTANT: Check the adjustments as instructed and make any final adjustments necessary *before* operating the unit. Check all nuts and bolts for tightness. Failure to follow these instructions may cause damage to unit.

Tire Pressure (Pneumatic Tires)

The tires are over-inflated for shipping purposes. Check tire pressure and reduce pressure, if needed, to 10-15 psi. Maintain equal pressure on both wheels of the snow thrower.



WARNING: Maximum tire pressure under any circumstance is 15 psi. Equal tire pressure should be maintained at all times. Excessive pressure (over 15 psi) when seating beads may cause tire/rim assembly to burst with force sufficient to cause serious injury

Skid Shoe

The space between the shave plate and the ground can be adjusted. Refer to Figure 6 for location of shave plate and skid shoes.

For close snow removal, place skid shoes in the low position. When the area to be cleared is uneven, place skid shoes in the middle or high position. See Figure 4.

NOTE: *It is not recommended that you operate this snow thrower on gravel as loose gravel can be easily picked up and thrown by the auger causing personal injury or damage to the snow thrower. However, if you have to operate the it on gravel, keep the skid shoe in the highest position for maximum clearance.*

- Adjust skid shoes by loosening two hex nuts and carriage bolts on each skid shoe, and moving the skid shoe to the desired position. See Figure 4.
- Make certain the entire bottom surface of skid shoe is against the ground to avoid uneven wear on the skid shoes.
- Tighten nuts and bolts securely.

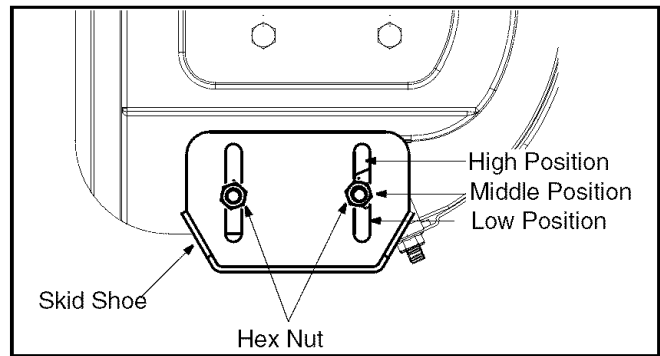

Figure 4

Drive Cable

- Make sure that the drive cable is routed parallel to the left upper handle, then across the top of the lower handle and finally parallel to the right lower handle.
- Three cable ties have been used to loosely tie the two control cables to the lower handle. Two of these cable ties are on each arm, and third on the top cross bar of the lower handle. Tighten these cable ties to secure the cable to the lower handle. See Figure 5.

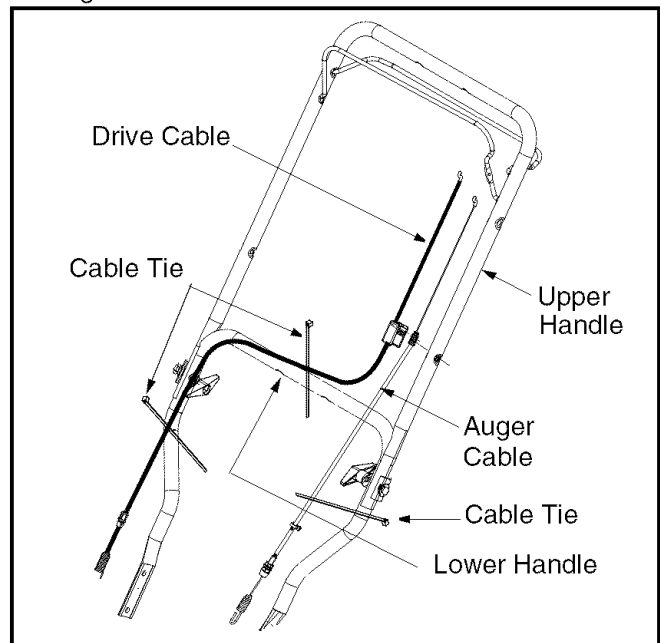

Figure 5

SECTION 3: KNOW YOUR SNOW THROWER



WARNING: Be familiar with all the controls on the snow thrower and their proper operation. Know how to stop the machine and disengage them quickly.

- Compare Figure 6 with your equipment and follow description of controls, given below, to get familiar with their operation.

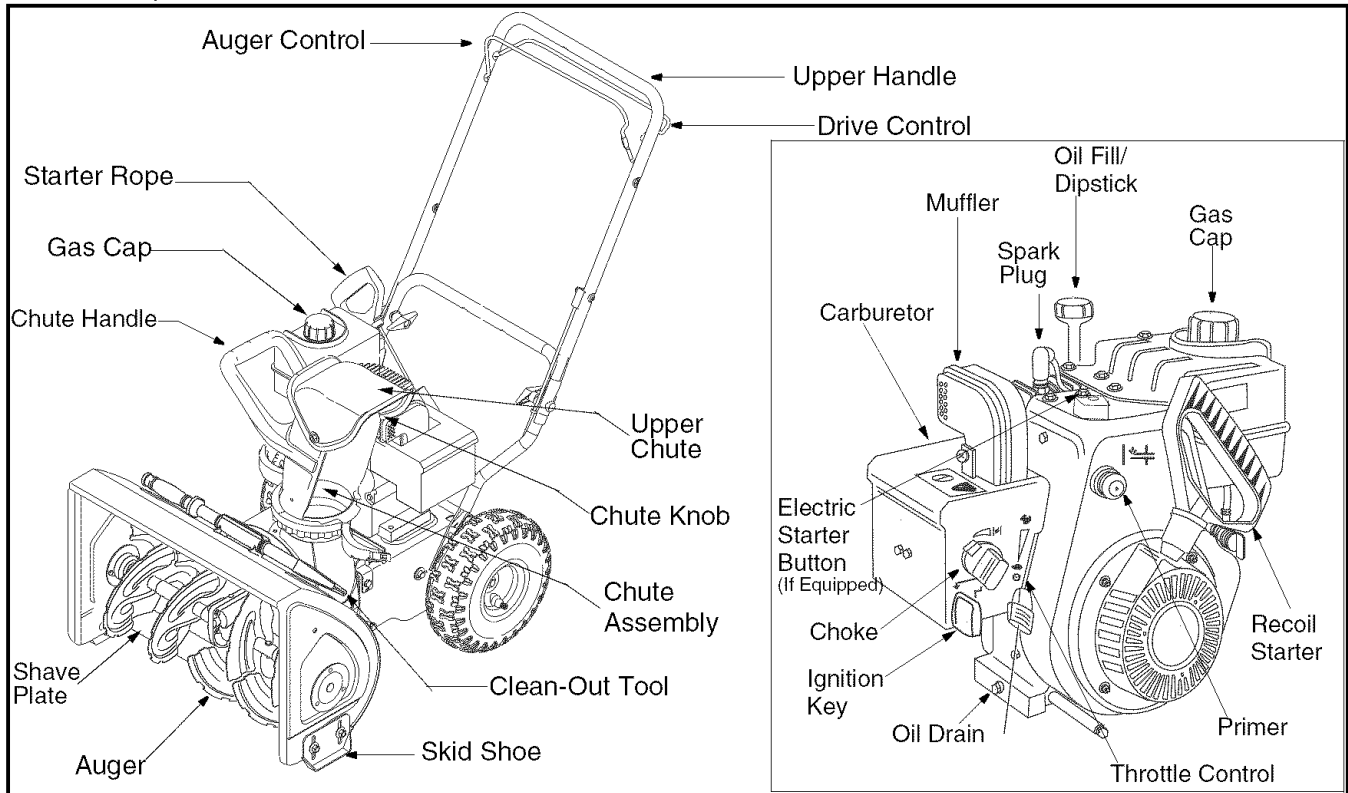

Figure 6

Throttle Control

The throttle control is located on the engine. It regulates the speed of the engine and also stops the engine.

Drive Control

Located on the underside of the upper handle, the drive control is used to engage/disengage wheels. Squeeze the drive control against the upper handle to engage the wheels; release to disengage.

Auger Control

The auger control is adjacent to the upper handle. Squeeze the auger control against the upper handle to engage the augers; release to disengage the augers.



WARNING: Never make adjustments to the chute assembly unless both auger and drive controls are disengaged and the operator is standing beside the unit.

IMPORTANT: Refer to Auger Control Test on page 9 prior to operating your snow thrower. Read and follow all instructions carefully and perform all adjustments to verify your snow thrower is operating safely and properly.

Chute Handle

The direction of snow throwing corresponds to the direction of the chute opening. Use the chute handle to turn the chute assembly in the direction you wish to throw the snow.

Chute Knob

The distance snow is thrown can be adjusted by either raising or lowering the upper chute. Loosen the chute knob on the side of the upper chute to adjust. Pivot the upper chute to desired position, and retighten the chute knob.

Ignition Key

The ignition key is necessary for the engine to start. Insert key and snap in place; do **not** turn it to start/stop the unit. Remove key when the unit is not in use.

Skid Shoe

The space between the shave plate and the ground can be adjusted. For close snow removal, place skid shoes in the low position. Use middle or high position when area to be cleared is uneven or on gravel surfaces.

SECTION 4: OPERATING YOUR SNOW THROWER

Before Starting Engine

Engine Oil

The engine is shipped with oil in it. Check the oil level before first use. For subsequent fill-ups, use the grade of engine oil specified in engine manual. To add oil:

1. Remove the dipstick from the oil fill. Pour fresh oil slowly through the plug. Replace dipstick.
2. Check and make sure that the level of oil is up to the FULL mark on the dipstick.

Gasoline



WARNING: Gasoline is flammable and caution must be used when handling or storing it. Do not fill fuel tank while the snow thrower is running, when it is hot or when it is in an enclosed area.



WARNING: Keep your snow thrower away from any open flame or an electrical spark and do not smoke during fueling.

- Never fill the fuel tank completely. Fill the tank to within 1/4"-1/2" from the top to provide space for expansion of fuel.

IMPORTANT: Your snow thrower is equipped with a plastic fuel plug for shipping purposes. Please discard it at this time.

- Always use clean, fresh, unleaded grade automotive gasoline. Fill the fuel tank outdoors and use a funnel or spout to prevent spilling. Make sure that the container from which you pour the gasoline is clean and free from rust or other foreign particles. Make sure to wipe off any spilled fuel before starting the engine.
- At the end of the job, empty the fuel tank if the snow thrower is not going to be used for 30 days or longer. Store gasoline in a clean container and keep the cap in place on the container.

CAUTION: Never use engine or carburetor cleaner products in the fuel tank.

To Start Engine



WARNING: Be sure **no one other than the operator** is standing near the snow thrower while starting or operating. **Do not operate** this snow thrower unless the chute assembly has been properly installed and is secured.

For location of all the engine controls referred to in this section, see Figure 6.

Recoil Starter

- Make sure that auger and drive controls are released. **Attach** spark plug wire to spark plug.
- Turn fuel valve on, if so equipped.
- Move throttle control to FAST position.
- Push key into the ignition slot so that it snaps into place. Do not turn key.
- Rotate choke control to FULL choke position.
- Push primer button while covering the vent hole. Remove your finger from the primer between primes. Do not prime if temperature is above 50° F; prime two times between 50° F and 15° F; and prime four times below 15° F.
- Grasp starter handle and pull rope out slowly until engine reaches start of compression cycle (rope will pull slightly harder at this point). Let the rope rewind slowly.
- Pull rope with a rapid, continuous, full arm stroke. Keeping a firm grip on the starter handle, let the rope return to the starter slowly. Repeat until engine starts.
- As the engine warms up, rotate the choke knob slowly to OFF position. If the engine falters, return to FULL choke, then slowly move to OFF choke position.
- Allow the engine to warm up for a few minutes because the engine will not develop full power until it reaches operating temperature.
- Operate the engine at full throttle (FAST) when throwing snow.

NOTE: *If the starter motor runs but the engine does not turn over, the starter gear may have frozen. Place the snow thrower in a warmer part of the garage or storage shed till the gear is free of the accumulated ice.*

Warm Start:

- If restarting an engine after a temporary shut-down, rotate choke to OFF instead of FULL and do **not** prime. Pull starter handle as instructed before.

Electric Starter (if equipped)

Some models of the snow thrower may be equipped with an optional 120 volt A.C. electric starter. This electric starter, with a three-wire power cord and plug, is designed to operate on 120 volt AC household current. Follow the steps below to use the electric starter.

Cold Start:

- Determine whether your house wiring is a three-wire grounded system. Ask a licensed electrician if you are not certain.



WARNING: The electric starter must be properly grounded at all times to avoid the possibility of electric shock to the operator. If your house wiring system is not a three-wire grounded system, do not use this electric starter under any conditions.

- **If your house wiring system is grounded and a three-hole receptacle is not available** at the point the snow thrower starter will normally be used, one should be installed by a licensed electrician.

NOTE: When connecting the power cord, always connect cord to starter on engine first, then plug the other end into a three-hole grounded 120 Volt receptacle. When disconnecting the power cord, always unplug the end from the three-hole, grounded receptacle first.

- **Attach** spark plug wire to spark plug.
- Make sure that the auger control and the drive control are disengaged.
- Remove the keys from the plastic bag. Push key into the ignition slot. Do **not** turn the key. Keep second key in a safe place.
- Move the choke knob to FULL choke position.
- Move throttle control to the FAST position.
- Turn fuel valve on, if so equipped.
- Connect power cord to the switch box on engine.
- Plug the other end of the power cord into a three-hole, grounded 120 volt A.C. receptacle.
- Push primer button three times.
- Push down on the starter button until the engine starts. Do not crank for more than 5 seconds at a time.



WARNING: Severe damage to electric starter is possible if you continue to crank for more than 5 seconds without a cool-down.

- When the engine starts, release the starter button and slowly rotate the choke to OFF position. If the engine falters, rotate the choke to FULL and then gradually to OFF.

NOTE: When engaging the electric starter, a slight hesitation of a few seconds may occur before the engine starts to turn. This is normal and is not harmful to the engine.

- Disconnect the power cord from the receptacle first and then from the switch box on the engine.
- Allow the engine to warm up for a few minutes because the engine will not develop full power until it reaches operating temperature.

Warm Start:

- If restarting a warm engine, rotate choke to OFF instead of FULL and press the starter button. Do not push the primer button.

Before Stopping

- Run engine for a few minutes to help dry off any moisture on engine.
- **To avoid possible freeze-up of the starter**, follow these steps:

Recoil Starter

- With the engine running, pull the starter rope with a rapid, continuous full arm stroke three or four times.

Electric Starter (if equipped)

- Connect power cord to switch box, then to 120 Volt AC receptacle.
- While the engine is running, push the starter button and spin the starter for several seconds.
- Disconnect power cord from the receptacle first, then from the snow thrower.

NOTE: The unusual sound from pulling the starter rope or from spinning the starter will not harm the engine.

- While standing in the operator's position (behind the snow thrower), engage the auger control for a few seconds to clear any remaining snow and ice from the chute assembly.

To Stop The Snow Thrower

- To stop the wheels, release the drive control.
- To stop throwing snow, release the auger control.
- To stop engine, push throttle control lever to OFF and pull out the key. Do **not** turn key.



WARNING: The temperature of muffler and the surrounding areas may exceed 150° F. Avoid these areas.

Auger Control Test

IMPORTANT: Perform the following test before operating the snow thrower for the first time and at the start of each winter season.

Check the adjustment of the auger control as follows:

- When the auger control is released and in the disengaged "up" position, the cable should have very little slack, but should NOT be tight.



WARNING: Do not over-tighten the cable. Over-tightening may prevent the auger from disengaging and compromise the safety of the snow thrower.

- In a well-ventilated area, start the snow thrower engine as instructed earlier in this section under the heading **Starting Engine**. Make sure the throttle is set in the FAST position.
- While standing in the operator's position (behind the snow thrower) engage the auger.

- Allow the auger to remain engaged for approximately ten (10) seconds before releasing the auger control. Repeat this several times.
- With the engine running in the FAST position and the auger control in the disengaged “up” position, walk to the front of the machine.
- Confirm that the auger has completely stopped rotating and shows NO signs of motion.

IMPORTANT: If the auger shows ANY signs of rotating, immediately return to the operator’s position and shut off the engine. Wait for all moving parts to stop before readjusting the auger control cable as shown in the “Making Adjustments” on page 10.

Clearing The Snow

CAUTION: Check the area to be cleared for foreign objects. Remove, if any.

- Start the engine following starting instructions.
- Allow the engine to warm up for a few minutes as the engine will not develop full power until it reaches operating temperature.
- Rotate the chute assembly to the desired direction, away from bystanders and/or buildings.
- Making certain no bystanders or obstacles are in front of the unit, squeeze the auger control completely against the upper handle to fully engage the augers.
- While the auger control is engaged, squeeze the drive control **completely** against the upper handle to engage the wheels. Do not “feather” the drive control.
- As the snow thrower starts to move, maintain a firm hold on the handle, and guide the snow thrower along the path to be cleared.
- Release the auger and drive controls to stop the snow throwing action and forward motion.

NOTE: Your unit is equipped with a clutch in the transmission. If the wheels stop turning while trying to discharge large volumes of snow, immediately disengage the drive control and allow the rotating augers to discharge snow from the housing. Reduce the clearing width and continue operation.

- On each succeeding pass, readjust the chute assembly to the desired position and slightly overlap the previously cleared path.

Operating Tips

- For most efficient snow removal, remove snow immediately after it falls.
- Discharge snow downwind whenever possible. Slightly overlap each previous swath.
- Set the skid shoes 1/4" below the scraper bar for normal usage. The skid shoes may be adjusted upward for hard-packed snow.

NOTE: It is not recommended that you operate this snow thrower on gravel as loose gravel can be easily picked up and thrown by the auger causing personal injury and/or damage to the snow thrower.

- If for some reason, you have to operate the snow thrower on gravel, keep the skid shoe in the highest position for maximum clearance between the ground and the shave plate.
- Clean the snow thrower thoroughly after each use.

Cleaning The Chute Assembly

The clean-out tool is conveniently fastened to the rear of the auger housing with a mounting clip.

When snow and ice collect in the chute assembly during operation, use this tool to safely clean the chute and chute opening. Follow the steps below to operate it.



WARNING: Stop engine by moving throttle lever to stop position and wait for **all** moving parts to stop before using the clean-out tool.

- Release both auger and drive controls.
- Stop the engine by moving throttle lever to stop position.
- Remove the clean-out tool from the clip which secures it to the rear of the auger housing.
- Use the shovel-shaped end of the clean-out tool to dislodge and scoop any snow and ice which has formed in and near the chute assembly.



WARNING: Never use your hands to clean snow and ice from the chute assembly or auger housing.

- Re-fasten the clean-out tool to the mounting clip on the rear of the auger housing. You can start operating your snow thrower now.

SECTION 5: MAKING ADJUSTMENTS

Auger Cable

Periodic adjustment to the auger control cable may be required due to normal stretch and wear on the belt.

Adjustment is needed if the augers seem to hesitate while turning, but the engine maintains speed, or continue turning with the auger control disengaged.

- Remove the self-tapping screw and press the tabs that secure the belt cover to the snow thrower housing. Pull the belt cover from around the engine and chute and keep it away. You can now access the auger cable.
- Tighten two hex nuts on the auger cable towards the spring to increase the tension on the auger belt. See Figure 7.
- Reassemble the belt cover.
- Start engine and verify auger control engages and disengages properly.

NOTE: If auger continues to rotate with the control disengaged, shut off engine and readjust.

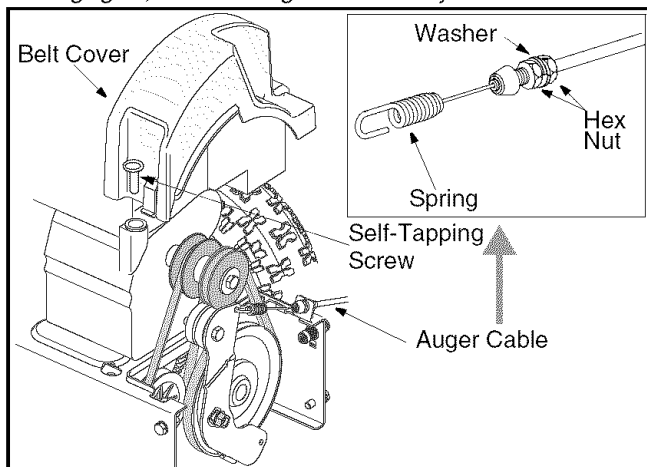

Figure 7

Skid Shoe

The space between the shave plate and the ground can be adjusted. For close snow removal, place skid shoes in the low position. Use middle or high position when area to be cleared is uneven.

1. Adjust skid shoes by loosening the four hex nuts and carriage bolts and moving skid shoes to desired position. See Figure 8. Make certain the entire bottom surface of skid shoe is against the ground to avoid uneven wear on the skid shoes.
2. Retighten nuts and bolts securely.

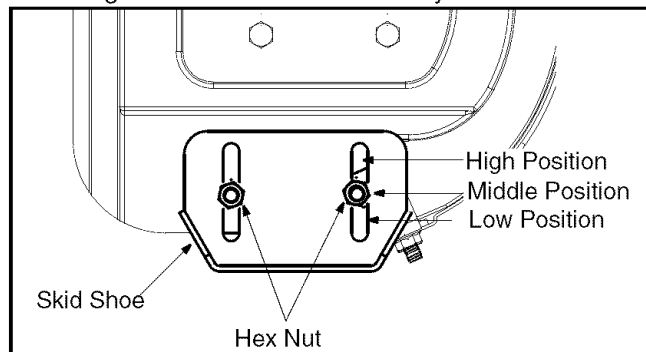

Figure 8

SECTION 6: MAINTAINING YOUR SNOW THROWER



WARNING: Before lubricating, repairing, or inspecting, disengage all controls and stop engine. Wait until all moving parts have come to a complete stop. Disconnect the spark plug wire and ground it against the engine to prevent unintended starting.

General Recommendations

1. Always observe safety rules when performing any maintenance.
2. The warranty on this snow thrower does not cover items that have been subjected to operator abuse or negligence. To receive full value from the warranty, operator must maintain the snow thrower as instructed in this manual.
3. Periodically check all fasteners and hardware to make sure these are tight.

Lubrication

For a view of the lubrication points on the snow thrower, see Figure 9.

- Lubricate pivot points on the auger control and drive control with a light engine oil once a season.
- Lubricate the auger idler bracket with a light engine oil once a season.

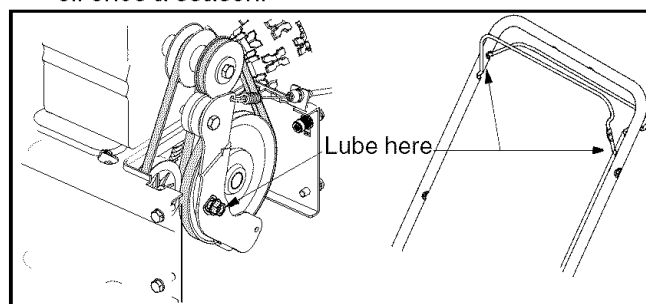

Figure 9

Engine

Listed below are general recommendations about maintaining your snow thrower engine. For further details, refer to the accompanying engine manual.

Check Oil Level

- Before operating snow thrower, check the oil level.

- With engine on level ground, oil must be to FULL mark on dipstick. See Figure 10.
- Stop engine and wait several minutes before checking oil level. Remove oil fill cap and dipstick.
- Wipe dipstick clean, insert it into oil fill hole and tighten securely.
- Remove dipstick and check. If oil is not up to the FULL mark on dipstick, add oil.

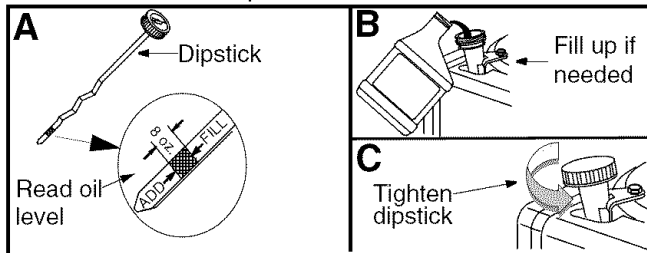

Figure 10

Change Oil

Change engine oil after first two hours of operation and every 25 hours thereafter.

In order to change oil, you will have to first drain the used engine oil from the engine and then refill with fresh oil.

- Drain oil while engine is warm. Remove oil drain plug located at the bottom of the recoil starter of the engine. Catch oil in a suitable container.
- When engine is drained of all oil, replace drain plug securely.
- Remove the dipstick from the oil fill. For location of the oil fill, see Figure 6. Pour fresh oil slowly through the plug. Replace dipstick.

- Check and make sure that the level of oil is up to the FULL mark on the dipstick.

Service Spark Plug

Clean spark plug and reset the electrode gap to 0.030" at least once a season or every 100 hours of operation; replace every 200 hours of operation.

- Clean area around the spark plug base.
- Remove and inspect the spark plug.
- Replace the spark plug if electrodes are pitted, burned, or the porcelain is cracked. See Figure 11.

NOTE: Do not sandblast spark plug. Spark plug should be cleaned by scraping or wire brushing and washing with a commercial solvent.

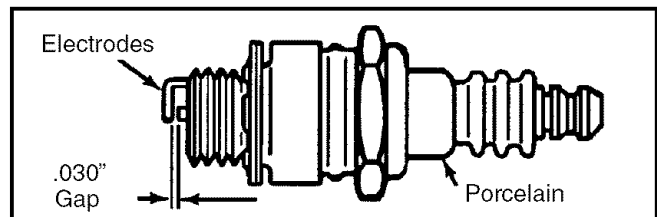

Figure 11

Check V-Belts

Follow instructions below to check condition of drive belts every 50 hours of operation.

- Remove the plastic belt cover on the front of the engine by removing the self-tapping screw and pressing the plastic tabs to release the belt cover.
- Visually inspect for frayed, cracked, or excessively worn out belts. Replace, if necessary, following instructions on page 13.

SECTION 7: SERVICING YOUR SNOW THROWER



WARNING: Before servicing, repairing, or inspecting, disengage all controls and stop engine. Wait until all moving parts have come to a complete stop. Disconnect spark plug wire and ground it against the engine to prevent unintended starting. Always wear safety glasses during operation or while performing any adjustments or repairs.

Shave Plate and Skid Shoes

The shave plate and skid shoes on the bottom of the snow thrower are subject to wear. These should be checked periodically and replaced when necessary.

- Remove two carriage bolts, and hex nuts which secure each skid shoe to the auger housing. See Figure 12.
- Reassemble new skid shoes with the hardware just removed. Make sure that the skid shoes are adjusted to be level.

- **To remove shave plate:** Remove both skid shoes and hardware including carriage bolts, and hex nuts which attach shave plate to the snow thrower housing. For location of shave plate, see Figure 12.
- Reassemble new shave plate, making sure heads of the carriage bolts are to the inside of the housing. Reinstall skid shoes. Tighten securely.

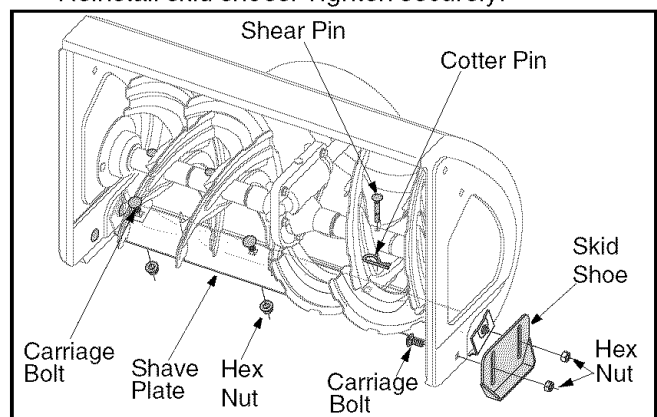

Figure 12

Replacing Belts

NOTE: There are two belts on this snow thrower: auger belt and drive belt. It is recommended that both belts be replaced at the same time.

- Remove the spark plug wire from the spark plug and ground it against the engine.
- Drain gasoline from the gas tank, or place a piece of plastic sheet underneath the gas cap to prevent gasoline leakage.
- Remove the self-tapping screw shown in Figure 13, and press the plastic tabs to release the belt cover. Pull the belt cover out from around the engine and the chute assembly. Remove it away and save.

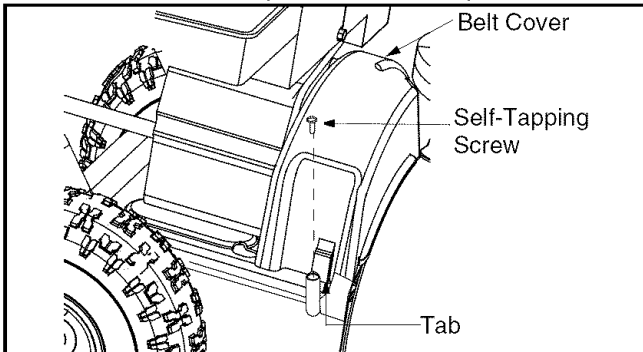

Figure 13

Auger Belt

- Slip the front auger belt off the engine pulley pushing it down between the idler bracket and the engine pulley. See Figure 14.
- Squeeze the auger control to release tension on the auger belt; remove the belt.
- Replace with new belt **after** replacing the drive belt. Follow instructions below to replace the drive belt:

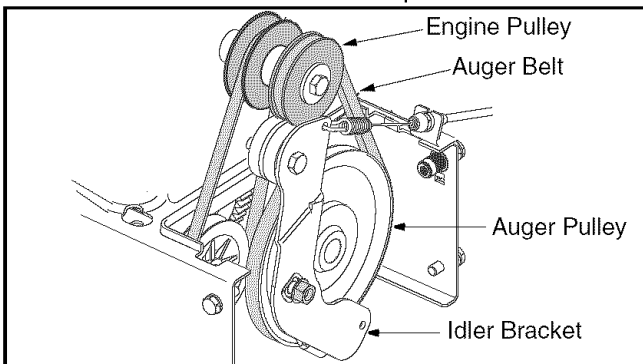

Figure 14

Drive Belt

NOTE: Replace the drive belt before reassembling the new auger belt.

- Tip the snow thrower up and forward so that it rests on the auger housing.
- Remove the spring that connects the transmission to a bolt on the engine frame. See Figure 15.

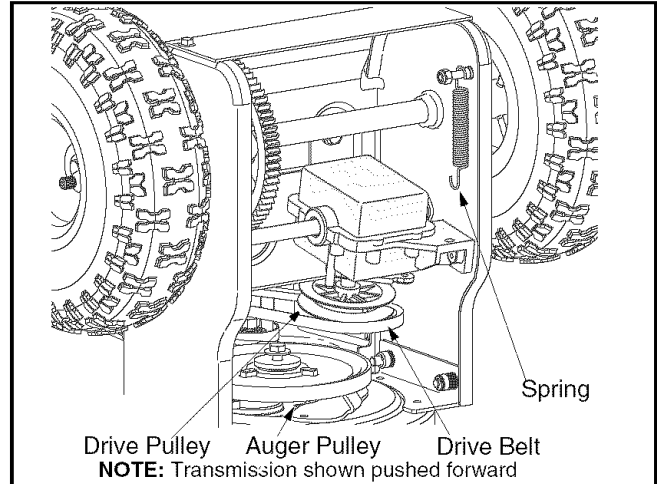

Figure 15

- Pivot the transmission forward to release pressure on the drive belt.
- Remove the drive belt from around the engine pulley, and away from the unit.
- Place the new drive belt into the groove on the engine pulley. See Figure 15.
- Tilt the transmission forward and position the drive belt on the drive pulley.
- Reconnect the spring to the bolt on the engine frame and secure the transmission.
- Reassemble the belt cover on the snow thrower.

Servicing Augers

The augers are secured to the spiral shaft with four shear pins and cotter pins. If you hit a foreign object or ice jam, the snow thrower is designed so that the pins may shear. Refer to Figure 12.

If the augers do not turn, check if the pins have sheared. Replace, if needed, with proper shear pins. refer to item 22 on page 18 for part number.

IMPORTANT: NEVER replace the auger shear pins with standard pins or fasteners. Any damage to the auger gearbox or other components, as a result of doing so, will NOT be covered by your snow thrower's warranty.

Off-Season Storage



WARNING: Never store engine with fuel in tank indoors or in poorly ventilated areas, where fuel fumes may reach an open flame, spark or pilot light as on a furnace, water heater, clothes dryer or other gas appliance.

- If unit is to be stored over 30 days, prepare engine for storage as instructed in the engine manual.

- Remove all debris from the exterior of equipment.
- Follow lubrication recommendations on page 11.
- Always store the snow thrower in a clean, dry area.

NOTE: When storing any type of power equipment in an unventilated or metal storage shed, care should be taken to rustproof the equipment. Using a light oil or silicone, coat the equipment, especially any chains, springs, bearings and cables.

SECTION 8: TROUBLESHOOTING

Problem	Possible Cause	Remedy
Engine fails to start	<ol style="list-style-type: none"> 1. Fuel tank empty, or stale fuel. 2. Blocked fuel line. 3. Choke not ON. 4. Faulty spark plug. 5. Key not in ignition switch. 6. Spark plug wire disconnected. 7. Primer not used properly. 	<ol style="list-style-type: none"> 1. Fill tank with fresh gasoline. 2. Clean the fuel line. 3. Turn Choke knob to ON position. 4. Clean, adjust or replace spark plug. 5. Insert the key fully; do not turn. 6. Attach spark plug wire to the spark plug on the engine. 7. Prime the engine as instructed earlier. If the carburetor is flooded due to over-priming, wait till it dries out.
Engine runs erratic	<ol style="list-style-type: none"> 1. Unit running at FULL choke. 2. Blocked fuel line or stale gasoline. 3. Water or dirt in fuel system. 	<ol style="list-style-type: none"> 1. Turn choke knob to OFF position. 2. Clean the fuel line, fill tank with fresh gasoline. 3. Drain fuel tank and carburetor. Fill up with fresh gasoline.
Engine loses power	<ol style="list-style-type: none"> 1. Spark plug wire loose. 2. Gas cap vent hole plugged. 	<ol style="list-style-type: none"> 1. Connect spark plug wire. 2. Remove ice and snow from gas cap. Be certain that vent hole is clear.
Excessive vibration	<ol style="list-style-type: none"> 1. Loose parts or damaged auger. 	<ol style="list-style-type: none"> 1. Stop the engine immediately and disconnect spark plug wire. Tighten all bolts and nuts. If vibration continues, contact service center.
Unit fails to propel itself	<ol style="list-style-type: none"> 1. Drive control cable not adjusted. 2. Drive belt loose or damaged. 	<ol style="list-style-type: none"> 1. Adjust drive control cable following earlier instructions. 2. Replace drive belt.
Unit fails to discharge snow	<ol style="list-style-type: none"> 1. Chute assembly clogged. 2. Shear pin sheared. 3. Foreign object lodged in auger. 4. Auger control cable out of adjustment. 5. Auger belt loose or damaged. 	<ol style="list-style-type: none"> 1. Stop engine and disconnect spark plug wire. Clean chute and inside of auger housing with clean-out tool or stick. 2. Replace shear pin. 3. Stop engine immediately and disconnect the spark plug wire. Remove object from auger. 4. Adjust auger control cable. 5. Replace auger belt.
Augers continue to rotate	<ol style="list-style-type: none"> 1. Cable out of adjustment. 	<ol style="list-style-type: none"> 1. Adjust auger control cable as shown in "Making Adjustments" on page 10.

NOTE: For repairs beyond minor adjustments listed above, contact an authorized service dealer.

SECTION 9: PARTS LIST FOR MODEL 3BA

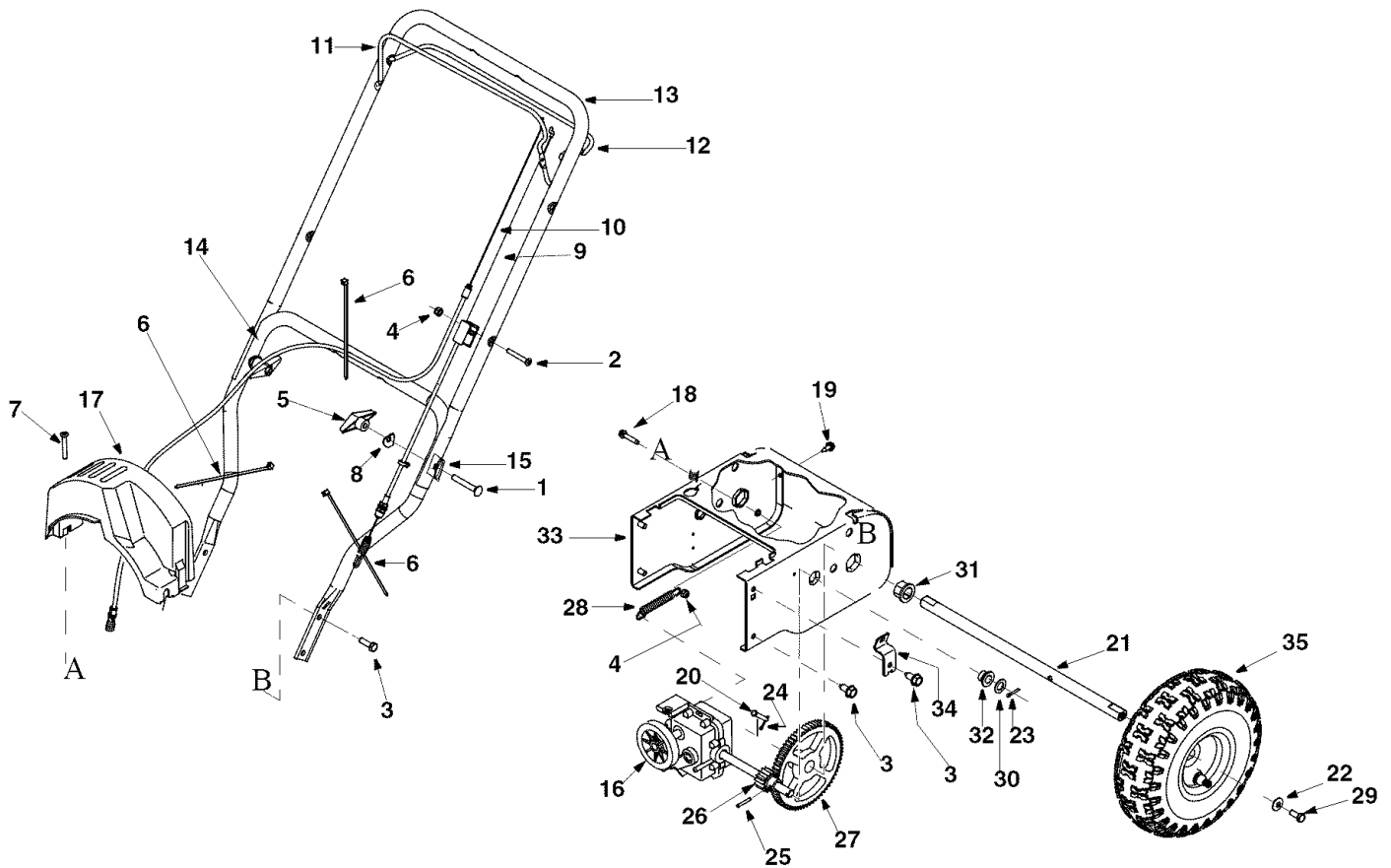

Ref. No.	Part No.	Description	Ref. No.	Part No.	Description
1.	710-0449	Carriage Screw 5/16-18 x 2.25"	19.	710-0896	Screw, 1/4-14 x .625"
2.	710-0605	Mach. Screw 1/4-20 x 1.825"	20.	711-1364	Clevis Pin
3.	710-0726	Screw, 5/16-12 x .75"	21.	738-1231	Axle
4.	712-04064	Flange Lock Nut 1/4-20	22.	736-0242	Bell Washer
5.	720-0284	Handle Knob Assembly	23.	714-0115	Cotter Pin, 1/8 x 1.0
6.	725-0157	Cable Tie	24.	714-0507	Cotter Pin, 3/32 x .750
7.	710-1003	Hex Screw, #10-16 x .625	25.	715-0249	Roll Pin
8.	736-0451	Saddle Washer	26.	717-04066	Pinion 14T
9.	746-04007	Auger Cable	27.	717-04073	Gear 70T
10.	746-04008	Drive Cable	28.	732-0429A	Extension Spring
11.	747-1161A	Auger Control	29.	710-0627	Lock Bolt 5/16-24 x 0.75"
12.	747-1214	Drive Control	30.	736-0192	Flat Washer
13.	749-1092A	Upper Handle	31.	741-0245	Hex Flange Bearing
14.	749-04147	Lower Handle	32.	741-04108	Hex Flange Bearing
15.	790-00053	Handle Tab	33.	784-0419A	Drive Housing Frame
16.	618-04008	Transmission Assembly	34.	790-00015	Auger Cable Bracket
17.	731-04162	Belt Cover	35.	634-0232	Wheel Assembly: Snow Hog Gray
18.	710-0809	TT Screw 1/4-20 x 1.25"			

Model 3BA

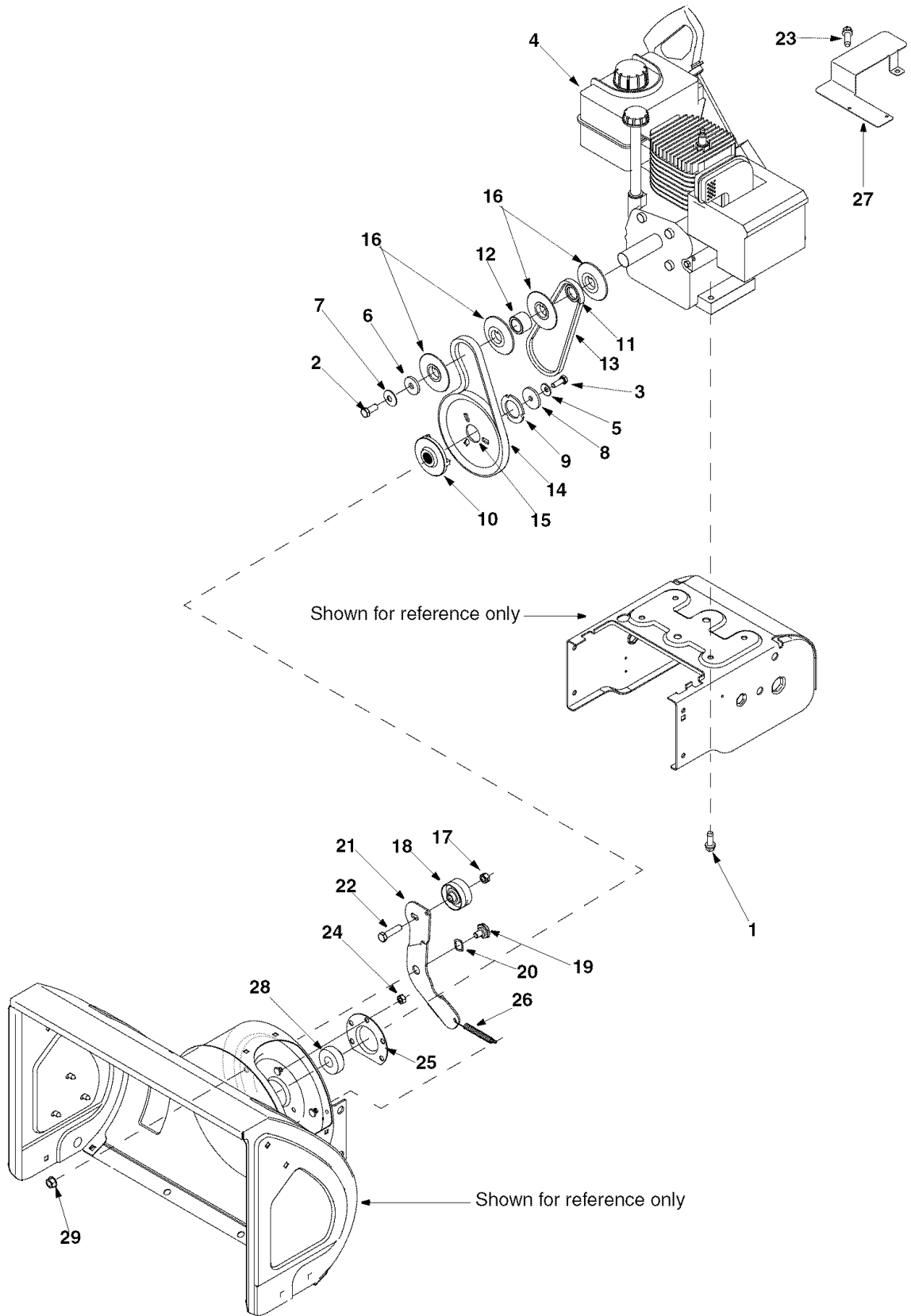

Model 3BA

Ref. No.	Part No.	Description
1.	710-0654A	TT Sems Screw 3/8-16 x 1.0"
2.	710-0696	Hex Bolt 3/8-24 x 0.875"
3.	710-1245B	Lock Bolt 5/16-24 x 0.875"
4.	—	Engine
5.	736-0242	Bell Washer,.340 x.872 x.060
6.	736-0247	Flat Washer,.406ID x 1.25OD
7.	736-0331	Bell Washer,.390 x 1.13 x.062
8.	736-0505	Flat Washer,.34ID x 1.50OD
9.	736-0507	Special Washer, 1.285 x 2.0 x.119
10.	748-0360	Pulley: Adapter,.75 Dia.
11.	750-1355	Spacer,.8760ID x 1.25OD x.1900
12.	750-1356	Spacer,.8760ID x 1.25OD x.86
13.	754-04013	V-Belt, 3/8 x 21.108 Lg.
14.	754-04014	V-Belt, 3/8 x 26.680 Lg.
15.	756-04024	Auger Pulley
16.	756-0569	Pulley Half
17.	712-3000	Hex Lock Nut 3/8-16
18.	756-04035	Flat Idler
19.	738-0281	Shoulder Screw 3/8-16
20.	736-0174	Wave Washer
21.	784-0434	Auger Idler Bracket
22.	710-0520	Hex Bolt 3/8-16 x 1.50"
23.	710-0456	Screw, #10-16 x.500
24.	712-04063	Flange Lock Nut, 5/16-18
25.	790-00075	Bearing Housing
26.	732-0611	Extension Spring
27.	790-00064	Heat Shield
28.	741-0309	Ball Bearing
29.	712-04065	Flange Lock Nut, 3/8-16

Model 3BA

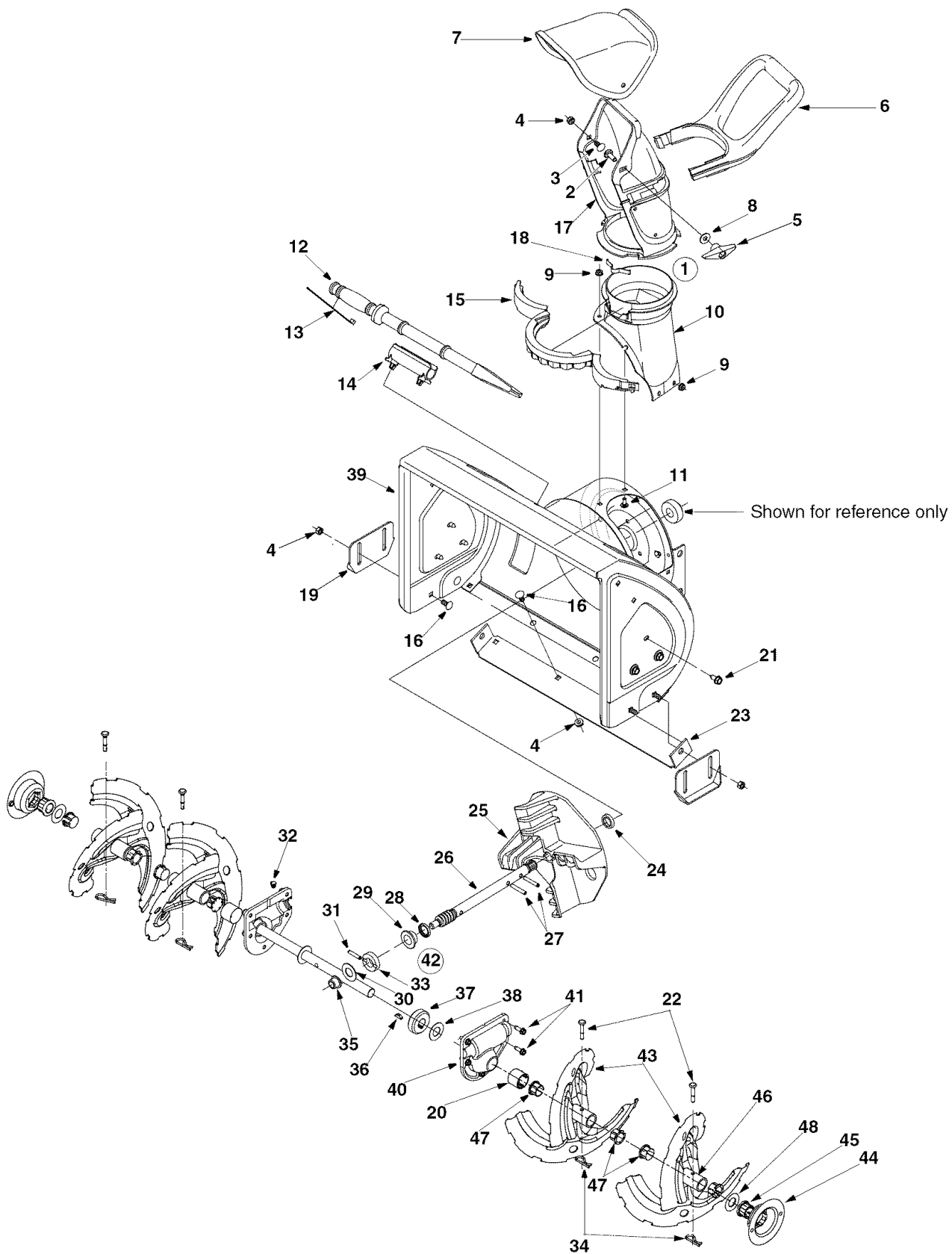

Model 3BA

Ref. No.	Part No.	Description	Ref. No.	Part No.	Description
1.	684-04037	Chute Assembly	26.	717-1772A	Worm Shaft
2.	710-04071	Carriage Bolt 5/16-18 x 1.0"	27.	715-04020	Spiral Pin
3.	710-0451	Carriage Bolt 5/16-18 x 0.750"	28.	721-0327	Oil Seal
4.	712-04063	Flange Lock Nut, 5/16-18	29.	741-0662	Flange Bearing
5.	720-0284	Chute Knob Assembly	30.	736-3084	Flat Washer, .51 x 1.12 x .06
6.	731-04388A	Chute Handle	31.	715-04021	Spiral Pin
7.	731-04426A	Upper Chute	32.	721-0325	Plug
8.	736-0159	Washer	33.	718-04071	Thrust Collar
9.	712-04064	Flange Lock Nut, 1/4-20	34.	714-0149B	Internal Cotter Pin
10.	731-2636A	Chute Adapter	35.	741-0663	Flange Bearing
11.	710-0134	Carriage Screw 1/4-20 x 0.62"	36.	714-0161	Key
12.	731-2643	Clean-out Tool	37.	717-0528A	Worm Gear 20T
13.	725-0157	Cable Tie	38.	736-0351	Flat Washer
14.	731-2635	Clean-out Tool Mount	39.	684-04089	Auger Housing, 22"
15.	731-04353	Lower Chute Ring	40.	618-0124	Reducer Housing Assembly LH
16.	710-0451	Carriage Bolt 5/16-18 x 0.75"		618-0123	Reducer Housing Assembly RH
17.	731-04127	Lower Chute	41.	710-0642	TT Screw 1/4-20 x 0.75"
18.	732-04111	Chute Adjuster Spring	42.	618-04181	Auger Gearbox Assembly
19.	784-5580	Skid Shoe	43.	684-04113	Auger Assembly - LH
20.	731-04870	Spacer, 1.25OD x .75ID x 1.00 Lg.		684-04114	Auger Assembly - RH
21.	710-0726	AB Screw 5/16-12	44.	790-00087	Hex Bearing Housing
22.	738-04124	Shear Pin, .25 x 1.50	45.	741-0245	Hex Flange Bearing
23.	790-00117	Shave Plate	46.	711-04286	Auger Axle
24.	750-04191	Spacer	47.	741-0493A	Flange Bushing
25.	731-04218A	Impeller	48.	736-0188	Flat Washer

MANUFACTURER'S LIMITED WARRANTY FOR:



The limited warranty set forth below is given by MTD LLC with respect to new merchandise purchased and used in the United States, its possessions and territories.

“MTD” warrants this product against defects in material and workmanship for a period of two (2) years commencing on the date of original purchase and will, at its option, repair or replace, free of charge, any part found to be defective in materials or workmanship. This limited warranty shall only apply if this product has been operated and maintained in accordance with the Operator’s Manual furnished with the product, and has not been subject to misuse, abuse, commercial use, neglect, accident, improper maintenance, alteration, vandalism, theft, fire, water, or damage because of other peril or natural disaster. Damage resulting from the installation or use of any part, accessory or attachment not approved by MTD for use with the product(s) covered by this manual will void your warranty as to any resulting damage.

Normal wear parts are warranted to be free from defects in material and workmanship for a period of thirty (30) days from the date of purchase. Normal wear parts include, but not limited to items such as: batteries, belts, blades, blade adapters, grass bags, rider deck wheels, seats, snow thrower skid shoes, shave plates, auger spiral rubber and tires.

HOW TO OBTAIN SERVICE: Warranty service is available, WITH PROOF OF PURCHASE, through your local authorized service dealer. To locate the dealer in your area, check your Yellow Pages, or contact MTD LLC at P.O. Box 361131, Cleveland, Ohio 44136-0019, or call 1-800-800-7310 or 1-330-220-4683 or log on to our Web site at www.mtdproducts.com.

This limited warranty does **not** provide coverage in the following cases:

- a. The engine or component parts thereof. These items may carry a separate manufacturer’s warranty. Refer to applicable manufacturer’s warranty for terms and conditions.
- b. Log splitter pumps, valves, and cylinders have a separate one year warranty.
- c. Routine maintenance items such as lubricants, filters, blade sharpening, tune-ups, brake adjustments, clutch adjustments, deck adjustments, and normal deterioration of the exterior finish due to use or exposure.
- d. Service completed by someone other than an authorized service dealer.

- e. MTD does not extend any warranty for products sold or exported outside of the United States, its possessions and territories, except those sold through MTD’s authorized channels of export distribution.
- f. Replacement parts that are not genuine MTD parts.
- g. Transportation charges and service calls.

No implied warranty, including any implied warranty of merchantability of fitness for a particular purpose, applies after the applicable period of express written warranty above as to the parts as identified. No other express warranty, whether written or oral, except as mentioned above, given by any person or entity, including a dealer or retailer, with respect to any product, shall bind MTD. During the period of the warranty, the exclusive remedy is repair or replacement of the product as set forth above.

The provisions as set forth in this warranty provide the sole and exclusive remedy arising from the sale. MTD shall not be liable for incidental or consequential loss or damage including, without limitation, expenses incurred for substitute or replacement lawn care services or for rental expenses to temporarily replace a warranted product.

Some states do not allow the exclusion or limitation of incidental or consequential damages, or limitations on how long an implied warranty lasts, so the above exclusions or limitations may not apply to you.

In no event shall recovery of any kind be greater than the amount of the purchase price of the product sold. **Alteration of safety features of the product shall void this warranty.** You assume the risk and liability for loss, damage, or injury to you and your property and/or to others and their property arising out of the misuse or inability to use the product.

This limited warranty shall not extend to anyone other than the original purchaser or to the person for whom it was purchased as a gift.

HOW STATE LAW RELATES TO THIS WARRANTY: This limited warranty gives you specific legal rights, and you may also have other rights which vary from state to state.

IMPORTANT: Owner must present Original Proof of Purchase to obtain warranty coverage.

MTD LLC, P.O. BOX 361131 CLEVELAND, OHIO 44136-0019; Phone: 1-800-800-7310, 1-330-220-4683