

1 LEVELERS

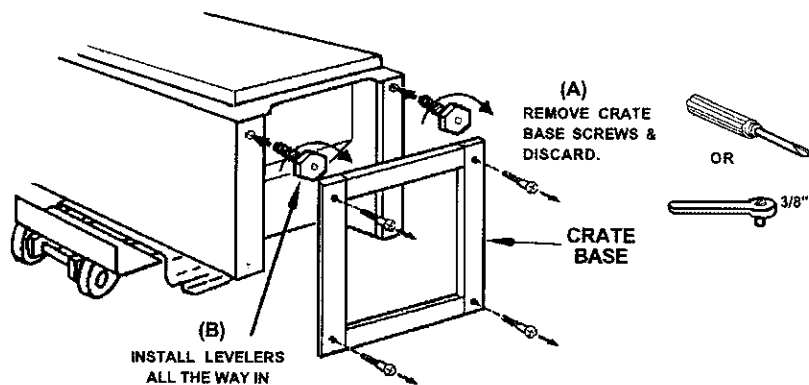

3 REFRIGERATOR LEVELING

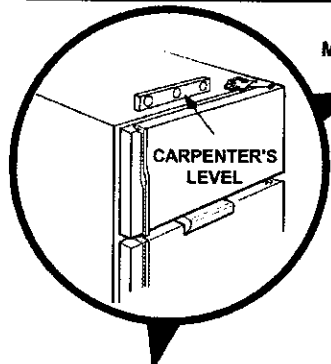

MOVE THE REFRIGERATOR TO ITS INSIDE LOCATION.

- (1) Level the cabinet. Open and close the doors. Re-level the cabinet.
- (2) If the cabinet rolls, extend the levelers.
- (3) If the doors do not close easily, raise the front of the cabinet.

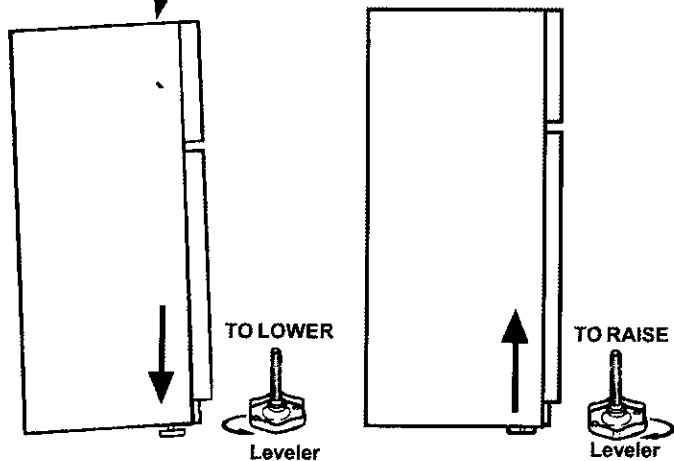

2 HANDLING

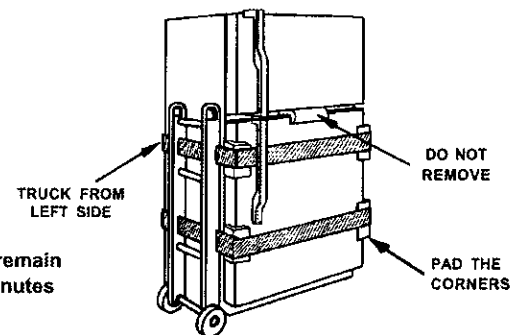

The refrigerator should remain upright for at least 30 minutes prior to plugging it in.

4 DOOR ADJUSTMENT (IF NEEDED)

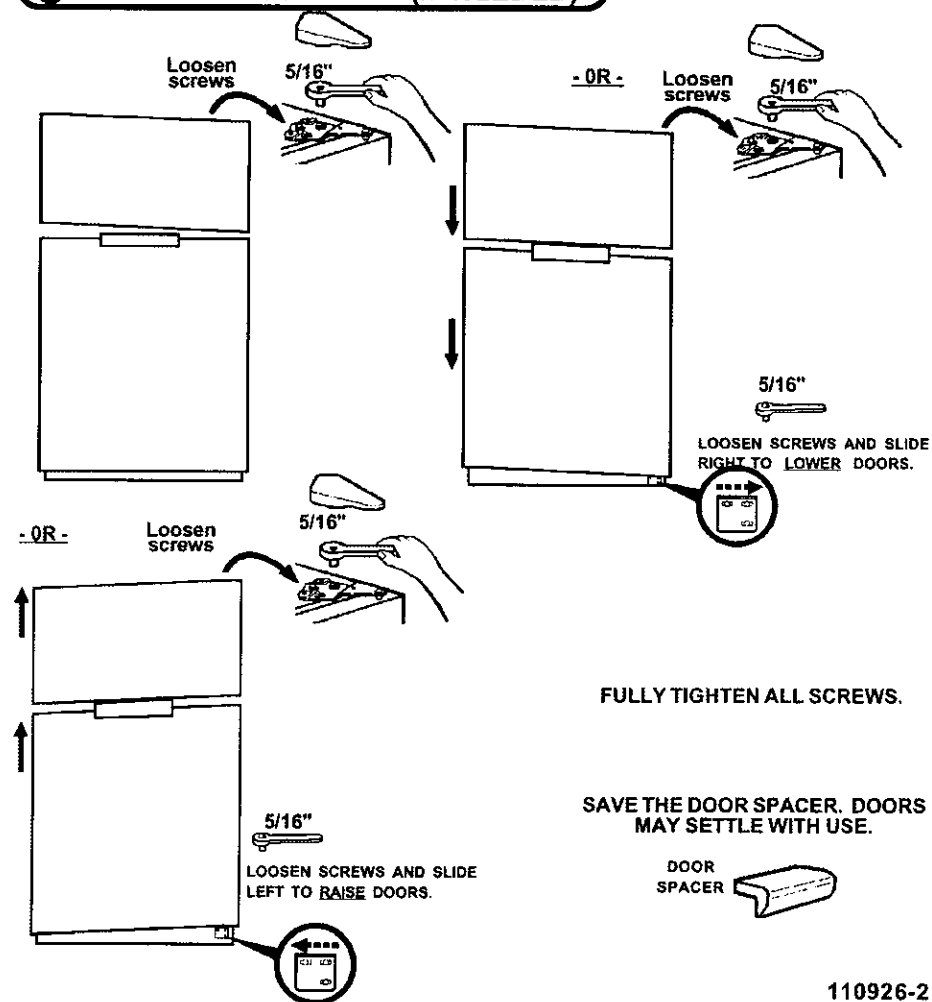

REMOVING DOORS (IF REQUIRED)

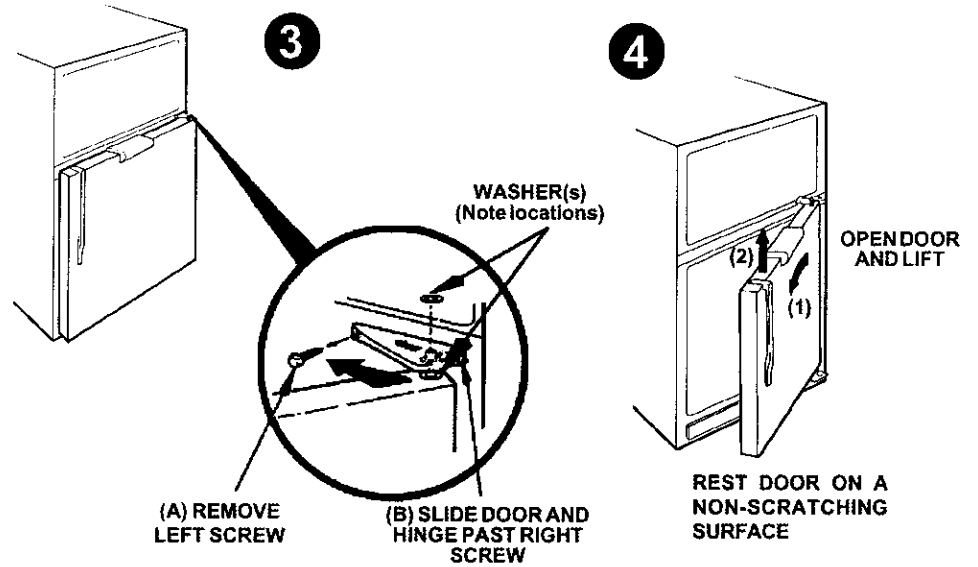
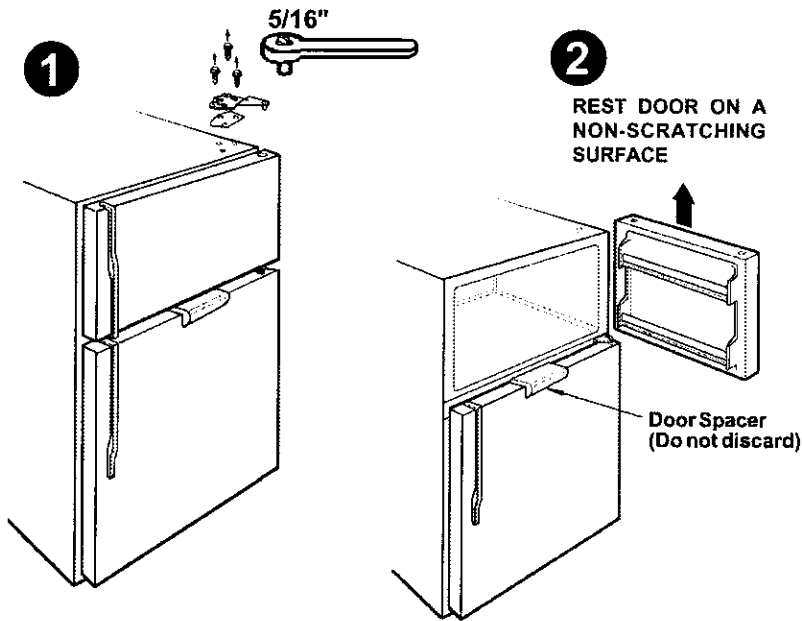

DOOR REVERSAL

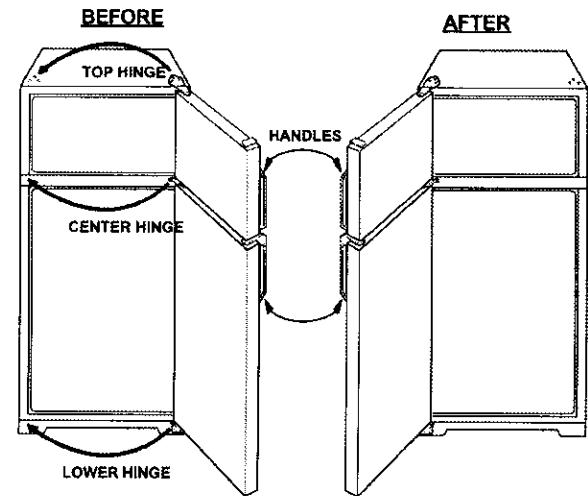
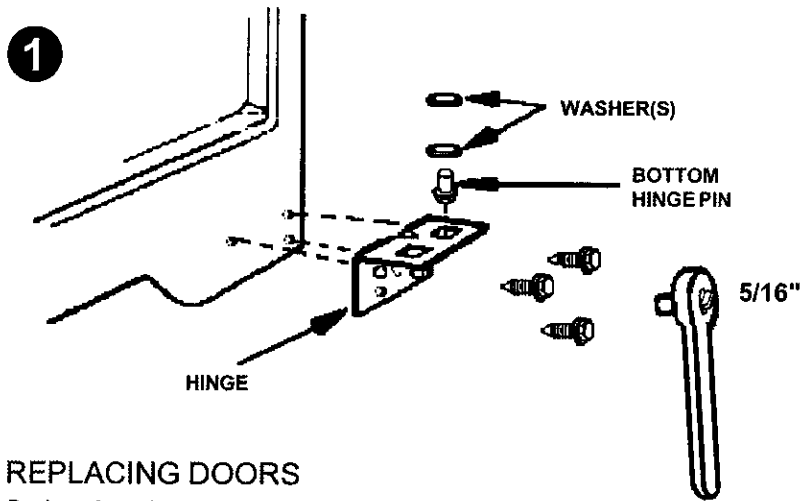

REPLACING DOORS

Replace doors in reverse order of their removal. Align doors using the door spacer.