

WEGA

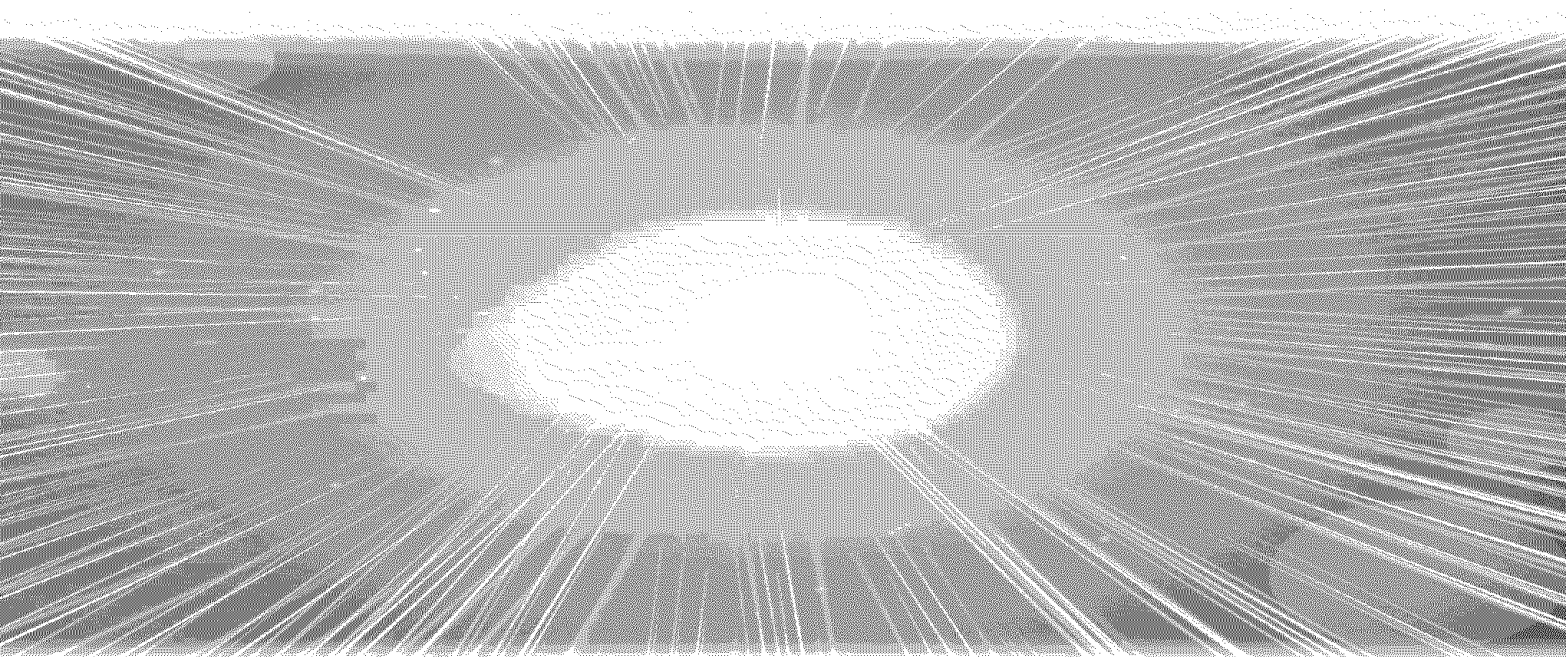

**Flat Panel Color TV
Operating Instructions**

KE-42M1



Owner's Record

The model and serial numbers are located at the rear of the TV.
Record these numbers in the spaces provided below. Refer to them
whenever you call upon your Sony dealer regarding this product.

Model No. _____

Serial No. _____

Contacting Sony

If, after reading the following instructions, you have additional
questions related to the use of your Sony TV, please call one of the
following numbers.

Customers in the continental United States contact the Direct
Response Center at:

1-800-222-SONY (7669)

Customers in Canada contact the Customer Relations Center at:

1-877-899-SONY (7669)

WARNING

To reduce the risk of fire or shock hazard, do not expose the TV to rain or moisture.

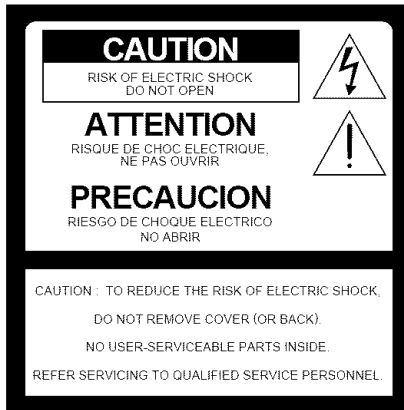

This symbol is intended to alert the user to the presence of uninsulated “dangerous voltage” within the product’s enclosure that may be of sufficient magnitude to constitute a risk of electric shock to persons.



This symbol is intended to alert the user to the presence of important operating and maintenance (servicing) instructions in the literature accompanying the appliance.

CAUTION

To prevent electric shock, do not use this polarized AC plug with an extension cord, receptacle or other outlet unless the blades can be fully inserted to prevent blade exposure.

Note on Caption Vision

This television receiver provides display of television closed captioning in accordance with §15.119 of the FCC rules.

Note to CATV System Installer

This reminder is provided to call the CATV system installer’s attention to Article 820-40 of the National Electrical Code (NEC) that provides guidelines for proper grounding and, in particular, specifies that the cable ground shall be connected to the grounding system of the building, as close to the point of cable entry as practical.

Use of this television receiver for other than private viewing of programs broadcast on UHF or VHF or transmitted by cable companies for the use of the general public may require authorization from the broadcaster/cable company and/or program owner.

NOTIFICATION

This equipment has been tested and found to comply with the limits for a Class B digital device pursuant to Part 15 of the FCC Rules. These limits are designed to provide reasonable protection against harmful interference in a residential installation. This equipment generates, uses, and can radiate radio frequency energy and, if not installed and used in accordance with the instructions, may cause harmful interference with radio communications. However, there is no guarantee that interference will not occur in a particular installation. If this equipment does cause harmful interference to radio or television reception, which can be determined by turning the equipment off and on, the user is encouraged to try to correct the interference by one or more of the following measures:

- Reorient or relocate the receiving antennas.
- Increase the separation between the equipment and receiver.
- Connect the equipment into an outlet on a circuit different from that to which the receiver is connected.
- Consult the dealer or an experienced radio/TV technician for help.

You are cautioned that any changes or modifications not expressly approved in this manual could void your authority to operate this equipment.

Safety

- Operate the TV only on 120 V AC.
- The plug is designed, for safety purposes, to fit into the wall outlet only one way. If you are unable to insert the plug fully into the outlet, contact your dealer.
- If any liquid or solid object should fall inside the cabinet, unplug the TV immediately and have it checked by qualified service personnel before operating it further.
- If you will not be using the TV for several days, disconnect the power by pulling the plug itself. Never pull on the cord.
- For details concerning safety precautions, see “Important Safeguards” on page 4.

Important Notice

- When used at an altitude of greater than 1,900m or 6,248feet (air pressure less than 800hPa), this Plasma Display Panel may generate a low buzzing sound as a result of the difference between the interior and exterior air pressure of the panels. This is not considered a defect and is not covered under by the Limited Warranty.

Installing

- To prevent internal heat buildup, do not block the ventilation openings.
- Do not install the TV in a hot or humid place, or in a place subject to excessive dust or mechanical vibration.
- Avoid operating the TV at temperatures below 5°C (41°F).
- If the TV is transported directly from a cold to a warm location, or if the room temperature changes suddenly, the picture may be blurred or show poor color due to moisture condensation. In this case, please wait a few hours to let the moisture evaporate before turning on the TV.
- To obtain the best picture, do not expose the screen to direct illumination or direct sunlight. It is recommended to use spot lighting directed down from the ceiling or to cover the windows that face the screen with opaque drapery. It is desirable to install the TV in a room where the floor and walls are not of a reflective material.

CAUTION

How to reduce the risk of “Image Retention” on your TV

When using TV games, computers, and similar products with your TV, or viewing a TV station whose logo always stays on the screen, keep the brightness and contrast functions at low settings.

Bright, stationary images such as TV station logos displayed on your TV can cause permanent damage to your TV, resulting in retention of the image in the picture. Please take the following steps to reduce the risk of causing image retention:

View a variety of program sources or programming material.

Image retention can occur when bright stationary images such as TV station logos are viewed. Changing the program material viewed reduces the possibility that a single image will become imprinted on the picture tubes in your TV.

When viewing programs with stationary images, adjust the picture setting to reduce the “Picture” and “Brightness” levels. Image retention is accelerated by higher “Brightness” and higher “Picture” settings.

Please see page 59 for instructions on adjusting picture settings.

This will help you reduce the risk of causing image retention.

IMAGE RETENTION IS NOT COVERED BY YOUR WARRANTY

(Continued)

CAUTION

Use the following SONY appliance(s) only with the following WALL-MOUNT BRACKET. Use with other WALL-MOUNT BRACKET may cause instability and result in possible injury.

SONY APPLIANCE MODEL NO.
KE-42M1

SONY WALL-MOUNT BRACKET
MODEL NO.
SU-PW2

To Customers

Sufficient expertise is required for installing the specified product. Be sure to subcontract the installation to Sony dealers or contractors and pay adequate attention to safety during the installation.



As an ENERGY STAR® Partner, Sony Corporation has determined that this product meets the ENERGY STAR® guidelines for energy efficiency. ENERGY STAR® is a U.S. registered mark.

Trademark Information

TruSurround, TruBass, SRS and the (●) symbol are trademarks of SRS Labs, Inc. TruSurround technology is incorporated under license from SRS Labs, Inc.

Licensed by BBE Sound, Inc. under USP4638258, 4482866. "BBE" and BBE symbol are trademarks of BBE Sound, Inc.

HDMI This TV incorporates High-Definition Multimedia Interface (HDMI™) technology. HDMI, the HDMI logo and High-Definition Multimedia Interface are trademarks or registered trademarks of HDMI Licensing LLC.

Wega, Steady Sound, Digital Reality Creation, Caption Vision, and CineMotion are registered trademarks of Sony Corporation.

Important Safeguards

Before using your TV, please read these instructions completely, and keep this manual for future reference.

Carefully observe and comply with all warnings, cautions and instructions placed on the set or described in the operating instructions or service manual.

WARNING

To guard against injury, the following basic safety precautions should be observed in the installation, use and servicing of the set.

Use

Power Sources

This set should be operated only from the type of power source indicated on the serial/model plate.

If you are not sure of the type of electrical power supplied to your home, consult your dealer or local power company. For those sets designed to operate from battery power, refer to the operating instructions.



Grounding or Polarization

This set is equipped with a polarized AC power cord plug (a plug having one blade wider than the other), or with a three-wire grounding type plug (a plug having a third pin for grounding). Follow the instructions below:

For the set with a polarized AC power cord plug

This plug will fit into the power outlet only one way. This is a safety feature. If you are unable to insert the plug fully into the outlet, try reversing the plug.



If the plug still fails to fit, contact your electrician to have a suitable outlet installed. Do not defeat the safety purpose of the polarized plug by forcing it in.

Wall outlet

Do not use a poor fitting outlet.

Insert the plug fully into the outlet. If it is loose, it may cause arcing and result in fire.

Contact your electrician to have the outlet changed.

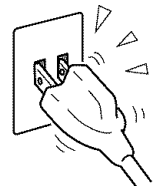

Wiring

Unplug the AC power cord when wiring cables.

Be sure to unplug the AC power cord for your safety, when hooking up.

Electric Shock

Do not touch the AC power cord or the unit with a wet hand.

If you plug/unplug the AC power cord from the unit with a wet hand, it may cause electric shock.



Cleaning

Clean the AC power plug regularly.

If the plug is covered with dust and it picks up moisture, its insulation may deteriorate and result in fire. Unplug the AC power plug and clean it regularly.

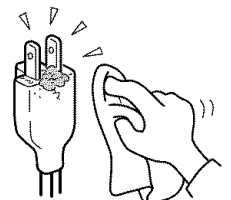

For the set with a three-wire grounding type AC plug

This plug will only fit into a grounding-type power outlet. This is a safety feature. If you are unable to insert the plug into the outlet, contact your electrician to have a suitable outlet installed. Do not defeat the safety purpose of the grounding plug.

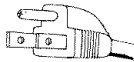

Overloading

Do not overload wall outlets, extension cords or convenience receptacles beyond their capacity, since this can result in fire or electric shock.

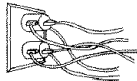

Always turn the set off when it is not being used. When the set is left unattended and unused for long periods of time, unplug it from the wall outlet as a precaution against the possibility of an internal malfunction that could create a fire hazard.



If a snapping or popping sound from a TV set is continuous or frequent while the TV is operating, unplug the TV and consult your dealer or service technician. It is normal for some TV sets to make occasional snapping or popping sounds, particularly when being turned on or off.

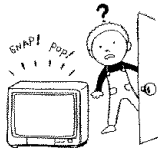

AC power cord

If you damage the AC power cord, it may result in fire or electric shock.

- Do not pinch, bend, or twist the cord excessively. The core lines may be bared and cut, and cause short-circuit, resulting in fire or electric shock.
- Do not convert or damage the AC power cord or display interface cable.
- Do not put anything heavy on the AC power cord. Do not pull the AC power cord.
- Keep the AC power cord away from heat sources.
- Be sure to grasp the plug when disconnecting the AC power cord.

If the AC power cord is damaged, stop using it and ask your dealer or Sony service center to exchange it.

Object and Liquid Entry

Never push objects of any kind into the set through the cabinet slots as they may touch dangerous voltage points or short out parts that could result in a fire or electric shock. Never spill liquid of any kind on the set.

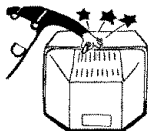

Ventilation holes

Do not insert anything in the ventilation holes. If metal or something flammable enters, it may result in fire or electric shock.



Cleaning

Unplug the AC power cord when cleaning this unit. If not, it may result in electric shock.

Clean the cabinet of the TV with a dry soft cloth. To remove dust from the screen, wipe it gently with a soft cloth. Stubborn stains may be removed with a cloth slightly dampened with a solution of mild soap and warm water. Never use strong solvents such as thinner or benzene for cleaning.



If the picture becomes dark after using the TV for a long period of time, it may be necessary to clean the inside of the TV. Consult qualified service personnel.

Attachments

Do not use attachments not recommended by the manufacturer, as they may cause hazards.

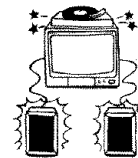

Medical institution

Do not place this unit in a place where medical equipment is in use.

It may cause malfunction of medical instruments.

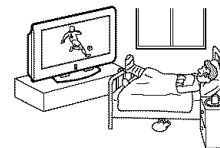

Moisture and flammable objects

- Do not use power-line operated sets near water — for example, near a bathtub, washbowl, kitchen sink, or laundry tub, in a wet basement, or near a swimming pool, etc. It may result in fire or electric shock.
- Do not let this unit get wet. Never spill liquid of any kind on the unit. If any liquid or solid object does fall through, do not operate the unit. It may result in electric shock or damage to the unit. Have it checked immediately by qualified personnel.
- To prevent fire, keep inflammable objects or naked lights (e.g. candles) away from the set.

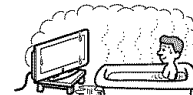

Accessories

Do not place the set on an unstable cart, stand, table or shelf. The set may fall, causing serious injury to a child or an adult and serious damage to the set. Use only a cart or stand recommended by Sony for the specific model of TV. No part of the TV set should overhang any edge of the TV cart or stand; any overhanging edge is a safety hazard. An appliance and cart combination should be moved with care. Quick stops, excessive force, and uneven surfaces may cause the appliance and cart combination to overturn.

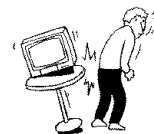

Dispose of used batteries

To preserve our environment, dispose the used batteries according to your local laws or regulations.

Damage requiring service

If the surface of the TV cracks, do not touch it until you unplug the AC power cord.

Otherwise electric shock may result.

Broken pieces

Do not throw anything at the unit.

The screen glass may explode by the impact and cause serious injury.

Cable wiring

Take care not to catch your feet on the cables. It may damage the unit.

Heat

Do not touch the surface of the TV.

It remains hot, even for some time after the TV is turned off.

(Continued)

Installation and moving

Carry the TV in the specified manner

Carrying the TV requires at least two people.

If you carry the TV in a manner other than that specified and without the specified number of persons, it may drop and a serious injury may result. Be sure to follow the instructions given below.

- Carry the TV with the specified number of persons.
- Carry the TV holding the upper and bottom frames of the TV as illustrated. Do not carry it holding the speaker units.
- Hold the TV securely when carrying it.
- As the glass surface of the TV has a special coating, be careful to avoid touching the glass surface as far as possible.
- When transporting, do not subject the set to shocks or vibration, or excessive force.

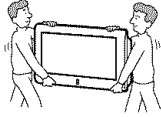

Installation

When installing the TV on the wall, be sure to have qualified contractors install and stay away from the unit. If a person other than the qualified contractors install the TV on the wall using a wall mount unit, the unit may fall and cause serious injury when the unit is not installed securely.

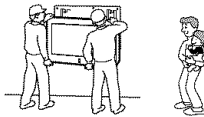

Optional accessories

Observe the following when installing the TV using a stand or wall mount unit. If the TV is not secured properly, it may fall and cause injury.

- Be sure to follow the operating instructions supplied with your stand or wall mount unit when installing the unit.
- Be sure to attach the brackets supplied with your stand or wall mount unit.

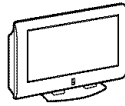

Protruding location

Do not install the TV in protruding locations. If you install the unit in the following locations, injury may result.

- Do not install the unit in a location where the unit protrudes, such as pillars.
- Do not install the unit in a location that may cause facial injury.

Oils

Do not install this unit in restaurants where oily vapors occur. Dust absorbing oil may enter into the unit and damage the unit.

Corrosion

If you use this unit near the seashore, salt may corrode metal parts of the unit and cause internal damage or fire.

It may also shorten the life of the unit.

Ventilation

The slots and openings in the TV are provided for necessary ventilation. To ensure reliable operation of the set, and to protect it from overheating, these slots and openings must never be blocked or covered.

Unless proper ventilation is provided, the unit may gather dust and get dirty. For proper ventilation, Observe the following:

- Do not install the unit turned backward or sideways.
- Do not install the unit turned over or upside down.



- Never cover the slots and openings with a cloth or other materials.



- Never block the slots and openings by placing the set on a bed, sofa, rug or other similar surface.



- Never place the set in a confined space, such as a bookcase or built-in cabinet, unless proper ventilation is provided.

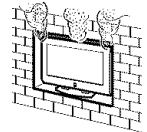

- Do not place the set near or over a radiator or heat register, or where it is exposed to direct sunlight.



Leave some space around the unit. Otherwise, adequate air-circulation may be blocked causing overheating and cause fire or damage the unit.

When installing the unit on the wall

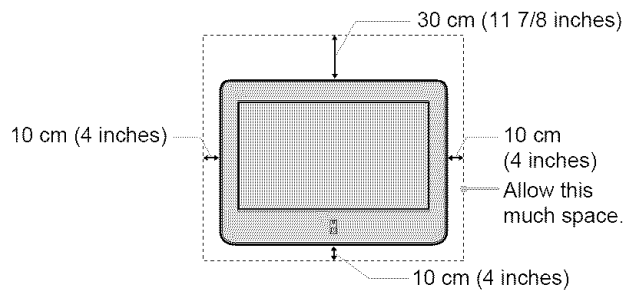

When installing the unit using a stand

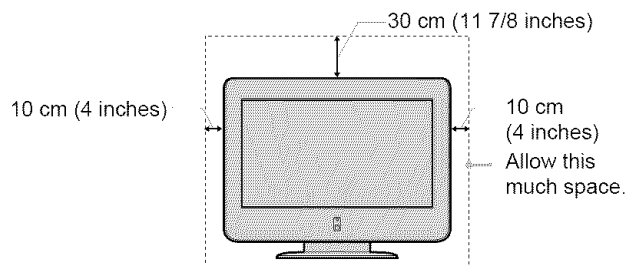

Never install the unit as follows:

Air circulation is blocked.

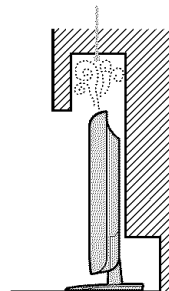

Air circulation is blocked.

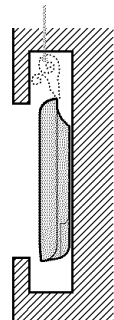

Outdoor use

Do not install this unit outdoors. If the unit is exposed to rain, it may result in fire or electric shock. If the unit is exposed to direct sunlight, the unit may heat up and it may damage the unit.

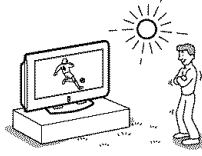

Vehicle and ceiling

Do not install this unit in a vehicle or hung from the ceiling.

Bumping of the vehicle may cause the set to fall down and cause injury.

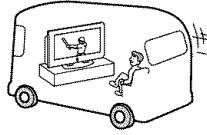

Ship and vessel

Do not install this unit in a ship or vessel. If the unit is exposed to seawater, it may cause fire or damage the unit.

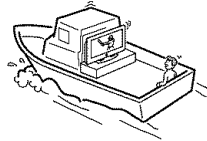

AC power cord

Unplug the AC power cord when moving the set.

Do not move the set with the AC power cord plugged in. It may damage the AC power cord and result in fire or electric shock.

Fall

Do not hang anything on the unit.

The unit may fall from the stand or wall mount unit, causing damage or serious injury.



Power-Cord Protection

Do not allow anything to rest on or roll over the power cord, and do not place the set where the power cord is subject to wear or abuse.

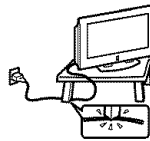

Antennas

Outdoor Antenna Grounding

If an outdoor antenna is installed, follow the precautions below. An outdoor antenna system should not be located in the vicinity of overhead power lines or other electric light or power circuits, or where it can come in contact with such power lines or circuits.

WHEN INSTALLING AN OUTDOOR ANTENNA SYSTEM, EXTREME CARE SHOULD BE TAKEN TO KEEP FROM CONTACTING SUCH POWER LINES OR CIRCUITS AS CONTACT WITH THEM IS ALMOST INVARIABLY FATAL.

Be sure the antenna system is grounded so as to provide some protection against voltage surges and built-up static charges.

Section 810 of the National Electrical Code (NEC) in USA and Section 54 of the Canadian Electrical Code in Canada provides information with respect to proper grounding of the mast and supporting structure, grounding of the lead-in wire to an antenna discharge unit, size of grounding conductors, location of antenna discharge unit, connection to grounding electrodes, and requirements for the grounding electrode.

Antenna Grounding According to the National Electrical Code, ANSI/NFPA 70

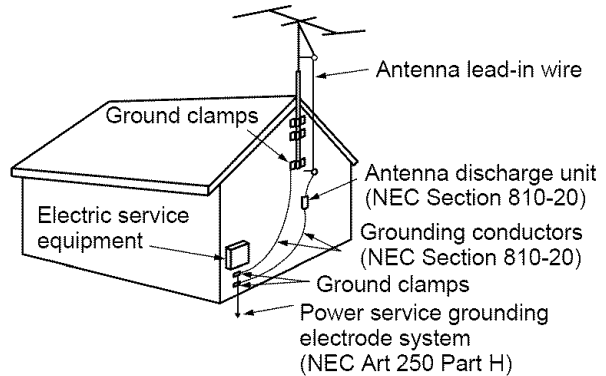

NEC: National Electrical Code

Lightning

For added protection for this television receiver during a lightning storm, or when it is left unattended and unused for long periods of time, unplug it from the wall outlet and disconnect the antenna. This will prevent damage to the receiver due to lightning and power-line surges.

(Continued)

Service

Damage Requiring Service

Unplug the set from the wall outlet and refer servicing to qualified service personnel under the following conditions:

- When the power cord or plug is damaged or frayed.
- If liquid has been spilled into the set.
- If the set has been exposed to rain or water.

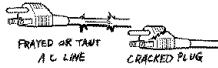

- If the set has been subject to excessive shock by being dropped, or the cabinet has been damaged.



- If the set does not operate normally when following the operating instructions. Adjust only those controls that are specified in the operating instructions. Improper adjustment of other controls may result in damage and will often require extensive work by a qualified technician to restore the set to normal operation.

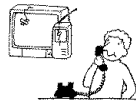
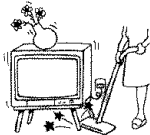

- When the set exhibits a distinct change in performance, it indicates a need for service.

Servicing

Do not attempt to service the set yourself since opening the cabinet may expose you to dangerous voltage or other hazards. Refer all servicing to qualified service personnel.



Replacement Parts

When replacement parts are required, be sure the service technician certifies in writing that he/she has used replacement parts specified by the manufacturer that have the same characteristics as the original parts.

Unauthorized substitutions may result in fire, electric shock or other hazards.



Safety Check

Upon completion of any service or repairs to the set, ask the service technician to perform routine safety checks (as specified by the manufacturer) to determine that the set is in safe operating condition, and to so certify. When the set reaches the end of its useful life, improper disposal could result in a picture tube implosion. Ask a qualified service technician to dispose of the set.



Important Safety Instructions

- 1) Read these instructions.
- 2) Keep these instructions.
- 3) Heed all warnings.
- 4) Follow all instructions.
- 5) Do not use this apparatus near water.
- 6) Clean only with dry cloth.
- 7) Do not block any ventilation openings. Install in accordance with the manufacturer's instructions.
- 8) Do not install near any heat sources such as radiators, heat registers, stoves, or other apparatus (including amplifiers) that produce heat.
- 9) Do not defeat the safety purpose of the polarized or grounding-type plug. A polarized plug has two blades with one wider than the other. A grounding type plug has two blades and a third grounding prong. The wide blade or the third prong are provided for your safety. If the provided plug does not fit into your outlet, consult an electrician for replacement of the obsolete outlet.
- 10) Protect the power cord from being walked on or pinched particularly at plugs, convenience receptacles, and the point where they exit from the apparatus.
- 11) Only use attachments/accessories specified by the manufacturer.
- 12) Use only with the cart, stand, tripod, bracket, or table specified by the manufacturer, or sold with the apparatus. When a cart is used, use caution when moving the cart/apparatus combination to avoid injury from tip-over.



- 13) Unplug this apparatus during lightning storms or when unused for long periods of time.
- 14) Refer all servicing to qualified service personnel. Servicing is required when the apparatus has been damaged in any way, such as power-supply cord or plug is damaged, liquid has been spilled or objects have fallen into the apparatus, the apparatus has been exposed to rain or moisture, does not operate normally, or has been dropped.

Table of Contents

Installing the TV

Unpacking	11
Overview of the Remote Control	11
Remote Control Descriptions	12
Programming the Remote Control ...	14
Using your Remote Controls with Other Equipment	16
Overview of the TV Controls and Connectors	18
Front Panel Controls and Connectors	18
Rear Panel Connectors	19
Preventing the TV from Falling Down	20

Connecting and Setting the TV

Basic Connections (Connecting Cable or an Antenna)	21
Connector types	21
Connecting directly to cable or an antenna	21
Cable box connections	21
Connecting Optional Equipment	22
Connecting the Power Cord	22
Connecting a VCR and Cable TV	23
Connecting a Satellite Receiver	24
Connecting a Satellite Receiver and a VCR	25
Connecting an Audio Receiver	26
Connecting a DVD Player with Component Video Connectors	27
Connecting a DVD Player with S Video and Audio Connectors	28
Connecting a Digital Cable Box	29
Connecting a Digital Satellite Receiver	30

Connecting a Digital Satellite Receiver with HDMI Connector	31
Connecting a DVD Player or Digital Satellite Receiver via AV Receiver with CENTER SPEAKER IN terminals	33
Connecting a Camcorder	34
Setting the TV	35
Setting the Channels	35
Using the Menu	37
Selecting the On-screen Menu Language	38

Watching the TV

Watching the TV	40
Watching with closed caption	41
Selecting the Picture Mode	42
Selecting the Effect Mode	43
Using the Wide Screen Mode	44
Changing the Wide Screen Mode	44
Changing the Wide Screen Mode using the menu	46
Using the Freeze Function	48
Using the Picture Off Function	48
Using the Center Speaker Feature	49
Setting the Center Speaker Mode	49
Listening to the center speaker sound from the TV's speakers	50
Adjusting the phase of the sound	51
Setting the Video Inputs	52
Using the Video Label and Skip Feature	53
Using Favorite Channels	54
Setting your favorite channels	54
Watching favorite channels	55
Using the Channel Label Feature	55

(Continued)

Using Advanced Features

- Adjusting the Picture Position Vertically 57
- Adjusting the Picture Position Horizontally 58
- Adjusting the Picture Quality 59
- Adjusting the Sound Quality 61
- Selecting Stereo or Bilingual Programs 62
 - Selecting stereo or bilingual programs using the menu 63
- Selecting How to Control the Volume of the TV's Speakers 63
- Selecting the TV Speakers or an External Amplifier to Listen to the TV 64
- Using the Parental Control Feature 65
 - Activating the Parental Control feature 66
 - Selecting a Custom Rating 68
- What the Ratings Mean 70
 - Ratings in the U.S.A. 70
 - Ratings in Canada 72
- Using the Screen Saver Function 74
- Turning Off the TV Automatically 75

Additional Information

- Troubleshooting 77
 - Self-diagnosis function 77
 - Trouble symptoms and remedies 77
- Specifications 79
- Index 80

Installing the TV

Overview of the Remote Control

Insert two size AA batteries (supplied) by matching the **+** and **-** on the batteries to the diagram inside the remote control's battery compartment.

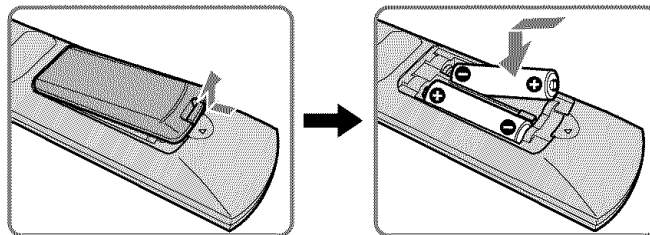

Unpacking

When you unpack this unit, make sure it includes the following:

Remote control (1) and size AA batteries (2)

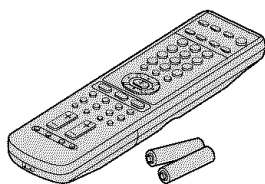

AC power cord (1)

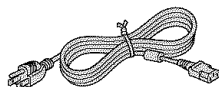

75-ohm coaxial cable (1)

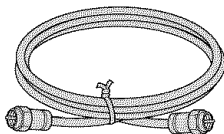

Clamp Screws (2)

Plug Holder for AC Power Cord (1)

Cleaning Cloth (1)

Operating Instructions (1)

Quick Setup Guide (1)

Warranty Card (1)

Notes

- Remove the batteries to avoid damage from possible battery leakage whenever you anticipate that the remote control will not be used for an extended period.
- Handle the remote control with care. Avoid dropping it, getting it wet, or placing it in direct sunlight, near a heater or where the humidity is high.
- The supplied remote control can be programmed to operate most video equipment (see "Programming the Remote Control" on page 14).

Remote Control Descriptions

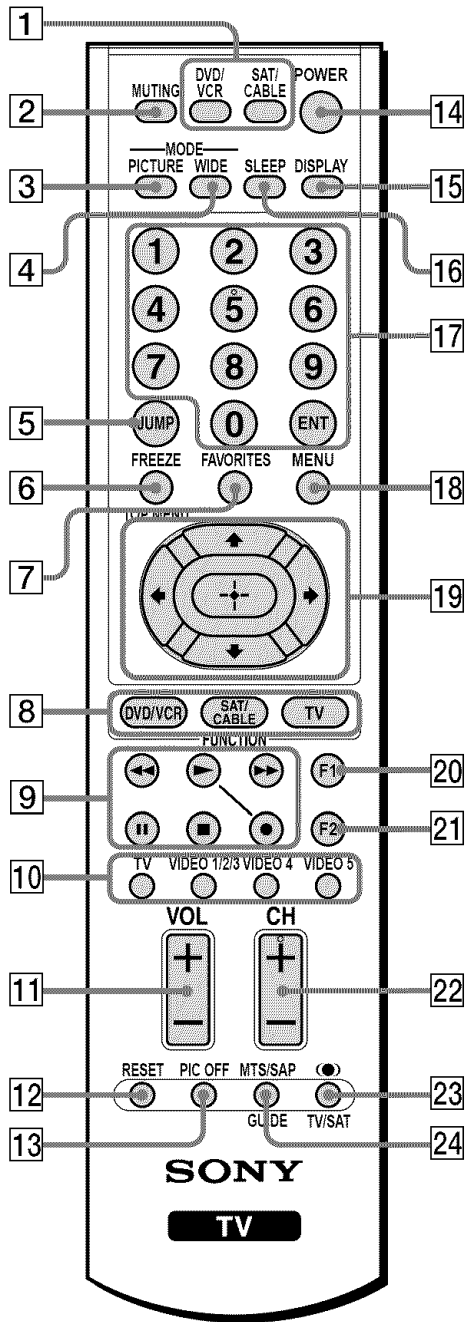







Tip

The MTS/SAP button, the number 5 button and the CH + button have a tactile dot.

Use the tactile dot as a reference when operating the TV.

Button	Description
1 DVD/VCR, SAT/CABLE Power Buttons	Press to turn on and off the equipment you have programmed into the remote control. For details, see "Programming the Remote Control" on page 14. DVD/VCR: Press to turn on and off the video equipment. SAT/CABLE: Press to turn on and off the satellite receiver or cable box.
2 MUTING	Press to mute the sound. Press again or press VOL+ to restore the sound.
3 PICTURE	Press repeatedly to cycle through the available video picture modes: Vivid, Standard, Pro. The video picture modes can be also accessed in the Video menu. For details, see "Adjusting the Picture Quality" on page 59.
4 WIDE	Press repeatedly to step through the Wide Screen Mode settings: Wide Zoom, Normal, Full, Zoom. The Wide Screen Mode settings can be also accessed in the Screen menu. For details, see pages 44 and 46.
5 JUMP	Press to jump back and forth between two channels. The TV alternates between the current channel and the last channel that was selected.
6 FREEZE	Press to freeze the picture. Press again to restore the picture. For details, see "Using the Freeze Function" on page 48.
7 FAVORITES	When FUNCTION is switched on DVD/VCR TOP MENU Press to display the top menu of your DVD/VCR.
8 FUNCTION Buttons	Press to display the Favorite Channels list. For details, see page 54.
9 DVD/VCR Operating Buttons	Press to have the remote control operate the equipment you want. For details, see "Programming the Remote Control" on page 14. When FUNCTION is switched on DVD/VCR, these buttons operate the video equipment you have programmed into the remote control. For details, see "Using your Remote Control with Other Equipment " on page 16.
	◀◀ Rewind
	▶ Play
	▶▶ Fast forward
	⏸ Pause
	■ Stop
	● Record

Button	Description
10 Input Select Buttons	<p>Press to select the video equipment connected to the TV's video inputs.</p> <p>TV: Press to select the TV to watch the TV programs.</p> <p>VIDEO 1/2/3: Press repeatedly to cycle through the video equipment connected to the VIDEO IN 1, the VIDEO IN 2 and the VIDEO IN 3.</p> <p>If the video label is selected as "Skip," the selected input will be skipped from the cycle.</p> <p>VIDEO 4: Press to select the video equipment connected to the HD/DVD IN 4.</p> <p>VIDEO 5: Press to select the video equipment connected to the HDMI IN 5.</p>
11 VOL +/-	Press to adjust the volume.
12 RESET	Press to reset the settings to the factory defaults. See pages 60 and 62. Also used to clear Channel Label.
13 PIC OFF	Press to turn off the TV screen. For details, see "Using the Picture off Function" on page 48.
14 POWER	Press to turn on and off the TV.
15 DISPLAY	Press once to display the current channel number, and channel label. If set, the current channel number will display for 10 seconds.
16 SLEEP	Press repeatedly until the TV displays the time in minutes (15, 30, 45, 60 or 90) that you want the TV to remain on before shutting off. To cancel Sleep Timer, press SLEEP repeatedly until Sleep Off appears.
17 0 - 9 ENTER	Press 0 - 9 to select a channel; the channel changes after 2 seconds. Press ENTER to change channels immediately.
18 MENU	Press to display the menu. Press again to exit from the menu. For details, see page 37.
19 	Press  /  /  /  to move the on-screen cursor. To select an item, press  .
20 F1	Press to select the function of your video equipment which is programmed on the TV's remote control.
21 F2	Press to select the function of your video equipment which is programmed on the TV's remote control.
22 CH +/-	Press to scan through channels. To scan quickly through channels, press and hold down either CH.

Button	Description
23 	<p>Press to select the sound effect modes: TruSurround, Off. The sound effect modes can be also accessed in the Audio menu. For more details, see "Selecting the Effect Mode" on page 43.</p> <p>When FUNCTION is switched on SAT/CABLE</p>
TV/SAT	Press to switch between the TV and the satellite receiver.
24 MTS/SAP	<p>Press repeatedly to cycle through the Multi-channel TV Sound (MTS) options: Stereo, Auto SAP (Second Audio Program), and Mono. The MTS setting can be also accessed in the Audio menu. For more details, see "Selecting Stereo or Bilingual Programs" on page 62.</p> <p>When FUNCTION is switched on SAT/CABLE</p>
GUIDE	Press to display the program guide of your satellite program provider.

Programming the Remote Control

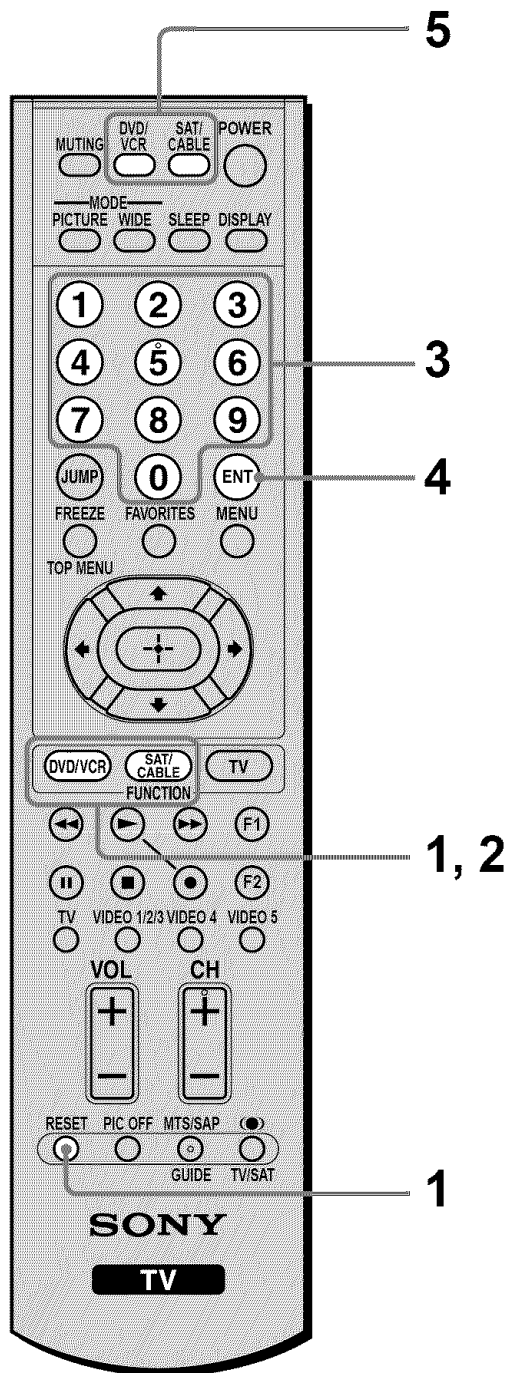

The remote control is preset to operate Sony brand video equipment.

Sony Equipment	Programmable Code Number
DVD/VCR	701 (Sony Dream System)
SAT/Cable	801 (Satellite Cable Box)

If you have video equipment other than Sony brand that you want to control with the TV's remote control, use the following procedures to program the remote control.

Note

The equipment must have infrared (IR) remote capability in order to be used with this remote control.

From the "Manufacturer's codes" listed on page 15, select the three-digit code number for the manufacturer's code of your equipment. If more than one code number is listed, try entering them one by one until you come to the correct code for your equipment. Use the code number to complete the following procedure.

- 1 Press the DVD/VCR (FUNCTION) and RESET buttons simultaneously, or press the SAT/CABLE (FUNCTION) and RESET buttons simultaneously.
- 2 Press the function button you want to program.
 - To program a cable box or a satellite receiver**
Press SAT/CABLE (FUNCTION).
 - To program video equipment**
Press DVD/VCR (FUNCTION).
- 3 Enter the three-digit manufacturer's code number using the 0-9 buttons.
- 4 Press ENT (enter).
- 5 To check if the code number works, aim the TV's remote control at the equipment and press DVD/VCR and/or SAT/CABLE (POWER) that corresponds with that equipment. If it responds, the programming is completed. If not, try using the other codes listed for that manufacturer.

Tips

- If you enter a new code number, the code number you previously entered at that setting is erased.
- In some rare cases, you may not be able to operate your equipment with the Sony remote control. In this case, use the equipment's own remote control unit.

Manufacturer's codes**DVD**

Manufacturer	Code
Sony	751
General Electric	755
Hitachi	758
JVC	756
Magnavox	757
Mitsubishi	761
Panasonic	753
Philips	757
Pioneer	752
RCA, Proscan	755
Samsung	758
Toshiba	754
Zenith	760

DVD changer

Manufacturer	Code
Sony	765
Panasonic	766

DVD 5.1ch

Manufacturer	Code
Sony (DAV)	601, 602, 603, 604

VCR

Manufacturer	Code
Sony	301, 302, 303
Admiral (M. Ward)	327
Aiwa*	338, 344
Audio Dynamic	314, 337
Broksonic	319, 317
Canon	309, 308
Citizen	332
Craig	302, 332
Curtis Mathes	304, 338, 309
Daewoo	341, 312, 309
DBX	314, 336, 337
Dimensia	304
Emerson	319, 320, 316, 317, 318, 341
Fisher	330, 335
Funai	338
General Electronics	329, 304, 309

Manufacturer	Code
Go Video	322, 339, 340
Goldstar	332
Hitachi	306, 304, 305, 338
Instant Replay	309, 308
JC Penney	309, 305, 304, 330, 314, 336, 337
JVC	314, 336, 337, 345, 346, 347
Kenwood	314, 336, 332, 337
LG	332
LXI (SEARS)	332, 305, 330, 335, 338
Magnavox	308, 309, 310
Marantz	314, 336, 337
Marta	332
Memorex	309, 335
Minolta	305, 304
Mitsubishi/MGA	323, 324, 325, 326
Multitech	325, 338, 321
NEC	314, 336, 337
Olympic	309, 308
Optimus	327
Orion	317
Panasonic	308, 309, 306, 307
Pentax	305, 304
Philco	308, 309
Philips	308, 309, 310
Pioneer	308
Quasar	308, 309, 306
RCA/PROSCAN	304, 305, 308, 309, 311, 312, 313, 310, 329
Realistic	309, 330, 328, 335, 324, 338
Sansui	314
Samsung	322, 313, 321
Sanyo	330, 335
Scott	312, 313, 321, 335, 323, 324, 325, 326
Sharp	327, 328
Signature 2000 (M.Ward)	338, 327
SV 2000	338

Manufacturer	Code
Sylvania	308, 309, 338, 310
Symphonic	338
Tashiro	332
Tatung	314, 336, 337
Teac	314, 336, 338, 337
Technics	309, 308
Toshiba	312, 311
Wards	327, 328, 335, 331, 332
Yamaha	314, 330, 336, 337
Zenith	331

Cable Box

Manufacturer	Code
Sony	230
Hamlin/Regal	222, 223, 224, 225, 226
Jerrold/G.I.	201, 202, 203, 204, 205, 206, 207, 208, 218, 222
Oak	227, 228, 229
Panasonic	219, 220, 221
Pioneer	214, 215
Scientific Atlanta	209, 210, 211
Tocom	216, 217
Zenith	212, 213

Satellite Receiver

Manufacturer	Code
Sony	801
Dish Network	810
Echostar	810
General Electric	802
Hitachi	805
Hugues	804
Mitsubishi	809
Panasonic	803
RCA/PROSCAN	802, 808
Toshiba	806, 807

* If an Aiwa VCR does not work even though you enter the code for Aiwa, enter the code for Sony instead.

Using your Remote Controls with Other Equipment

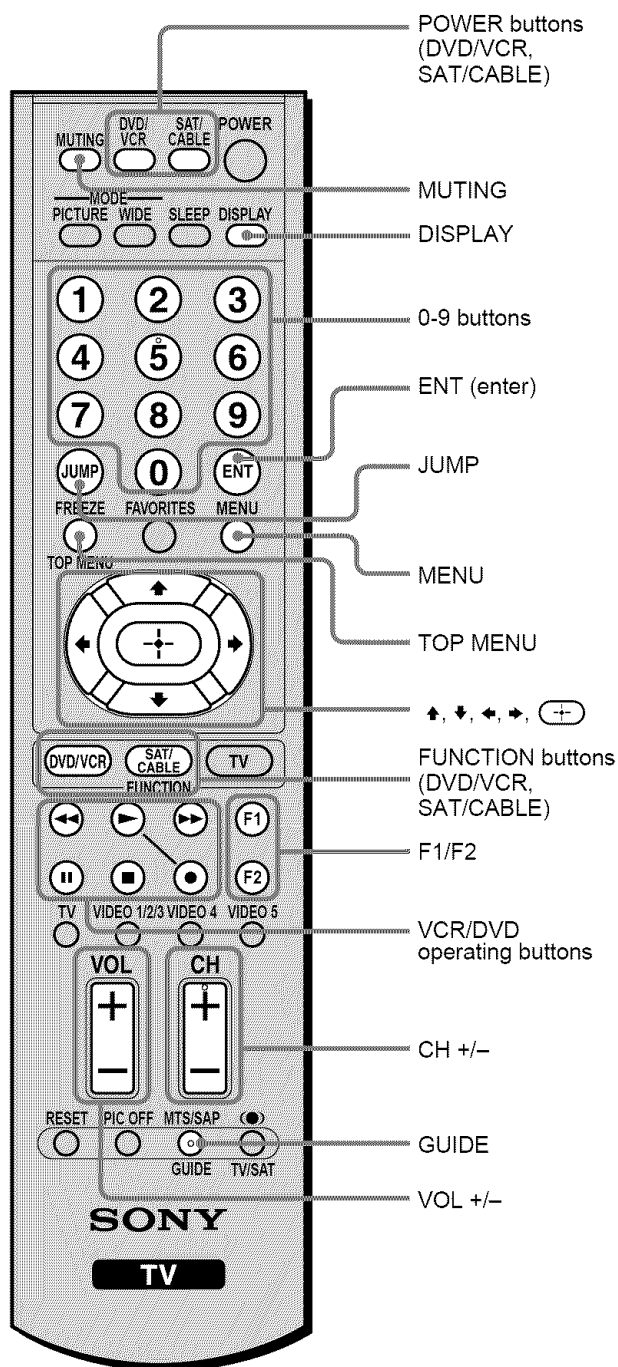

Operating a cable box

To	Press
Turn on/off	SAT/CABLE (POWER)
Control a cable box	SAT/CABLE (FUNCTION)
Select a channel	0-9 buttons, ENT (enter)
Change channels	CH +/-
Go to the previous channel	JUMP

Operating a satellite receiver

To	Press
Turn on/off	SAT/CABLE (POWER)
Control a satellite receiver	SAT/CABLE (FUNCTION)
Select a channel	0-9 buttons, ENT (enter)
Change channels	CH +/-
Go to the previous channel	JUMP
Display the channel number	DISPLAY
Display the DBS guide	GUIDE
Display the DBS menu	MENU
Move the highlight (cursor)	↑, ↓, ←, →
Select the item	+

Operating a VCR

To	Press
Turn on/off	DVD/VCR (POWER)
Control a VCR	DVD/VCR (FUNCTION)
Change channels	CH +/-
Record	▶ and ● simultaneously
Play	▶
Stop	■
Fast forward	▶▶
Rewind	◀◀
Pause	(press again to resume normal playback)
Search the picture forward or backward	▶▶ or ◀◀ during playback (release to resume normal playback)

Operating a DVD player or DVD Changer

To	Press
Turn on/off	DVD/VCR (POWER)
Control a DVD player	DVD/VCR (FUNCTION)
If you have a DVD changer, to skip disks	F1
Play	▶
Stop	■
Pause	⏸ (press again to resume normal playback)
Step through different tracks of an audio disc	▶▶ to step forward or ◀◀ to step backward
Step through different chapters of a video disc	CH + to step forward or CH - to step backward
Select a track directly	0-9 buttons
Display the menu (Setup)	MENU
Display the top menu	TOP MENU
Operate the DVD menu	↑, ↓, ←, →, (⊕)

Operating a DVD 5.1 Channel (Sony DAV)

To	Press
Turn on/off	DVD/VCR (POWER)
Select other equipment connected to the DAV	F1
Skip a disk	F2
Display the DVD menu	TOP MENU
Display the menu (Setup)	MENU
Move the highlight (Cursor)	↑, ↓, ←, →
Select the item	(⊕)
Change the volume	VOL +/-, MUTING

Overview of the TV Controls and Connectors





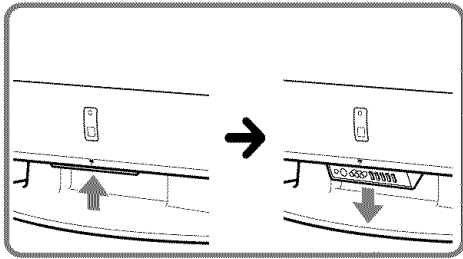

Front Panel Controls and Connectors

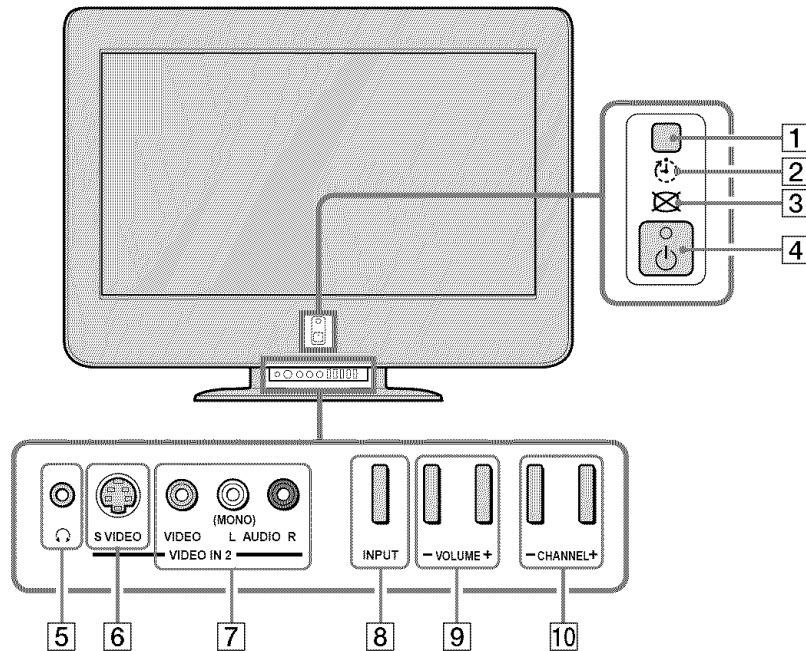
To open the drop-down panel





To open the drop-down panel of your TV, push up the panel door just under the  mark until you hear a click, then the panel door will open.

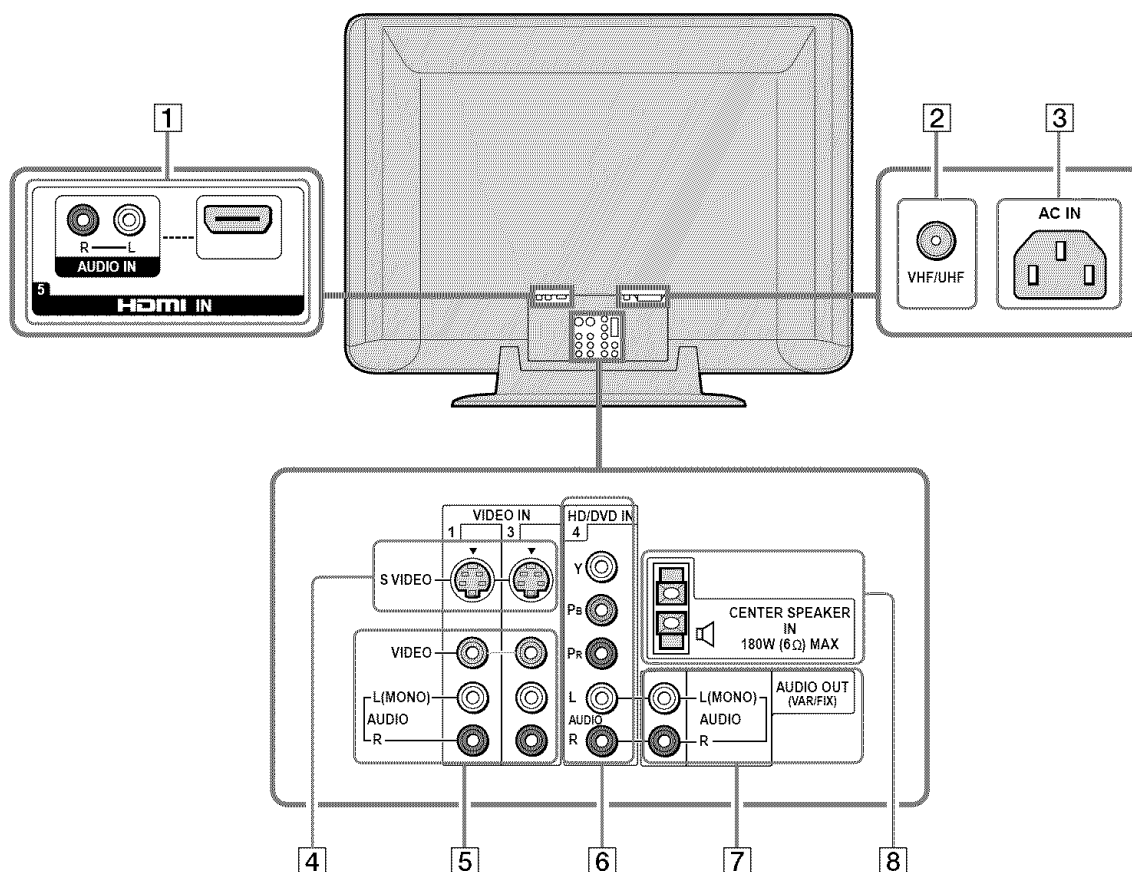

Item/Jack	Description
1 (IR) Infrared Receiver	Receives IR signals from the remote control.
2  (Timer) LED	When lit, indicates one of the timers is set. When the timer is set, this LED will remain lit. For details, see page 75.
3  (Picture off) LED	When lit, indicates that the Picture Off feature is activated. For details, see page 48.
4  (Power) and  (Power on/Stand by) LED	Press  (Power) to turn on and off the TV. The LED lights up green when the TV is turned on. When in standby mode, the LED lights up in red. If the LED blinks continuously, this may indicate the TV needs servicing (see page 77).
5  Headphones jack	Connects to your headphones. If your headphones do not match the jack, use a suitable plug adaptor (not supplied).
6 S VIDEO IN 2	Connects to the S VIDEO OUT jack on your camcorder or other video equipment that has S VIDEO. Provides better picture quality than composite video (7).
7 VIDEO/L-AUDIO-R VIDEO IN 2	Connects to the composite A/V output jacks on your camcorder or other video equipment.
8 INPUT	Press repeatedly to cycle through the video equipment connected to the TV's video inputs.
9 - VOLUME +	Press to adjust the volume.
10 - CHANNEL +	Press to scan through channels. To scan quickly through channels, press and hold down either CHANNEL.

Rear Panel Connectors



Jack	Description
1 HDMI IN/L-AUDIO-R (HDMI IN 5)	HDMI (High-Definition Multimedia Interface) provides an uncompressed, all-digital audio/video interface between this TV and any HDMI-equipped audio/video component, such as a set-top box, DVD player, and A/V receiver. HDMI supports enhanced, or high-definition video, plus multi-channel digital audio.
2 VHF/UHF	RF input that connects to your VHF/UHF antenna or cable box.
3 AC IN	Connects the supplied AC power cord.
4 S VIDEO IN 1/3	Connects to the S VIDEO OUT jack of your VCR or other video equipment that has S VIDEO. S VIDEO provides better picture quality than either composite video (5) or VHF/UHF (2) connections.
5 VIDEO IN 1/3 VIDEO/L-AUDIO-R	Connect to the composite A/V output jacks on your VCR or other video component. A third composite A/V input jack (VIDEO IN 2) is located on the front panel of the TV. These video connections provide better picture quality than the VHF/UHF (2) connections.
6 HD/DVD IN 4 Y, Pb, Pr/L-AUDIO-R	Connect to your DVD player's or digital set-top box's component video (Y, Pb, Pr) and audio (L/R) jacks. Component video provides better picture quality than the S VIDEO (4), the VHF/UHF (2) or the composite video (5) connections.
7 AUDIO OUT (VAR/FIX) L/R	Connects to the left and right audio input jacks of your audio or video equipment. You can use these outputs to listen to your TV's audio through your stereo system.
8  CENTER SPEAKER IN 180W (6Ω) MAX	Connect the center output terminals of a Dolby Pro Logic* system decoder amplifier. You can use the TV speakers as a center speaker.

* "Dolby", "Pro Logic", and the double-D symbol are trademarks of Dolby Laboratories.

Preventing the TV from Falling Down

After connections with antennas and other equipment are completed, be sure to attach the supplied clamp screws to the rear of the TV, and pass a sturdy cord or chain and attach it to a wall or pillar.

- 1** Remove one of the two screws at the rear of the TV, then attach the supplied clamp screw to the screw hole.

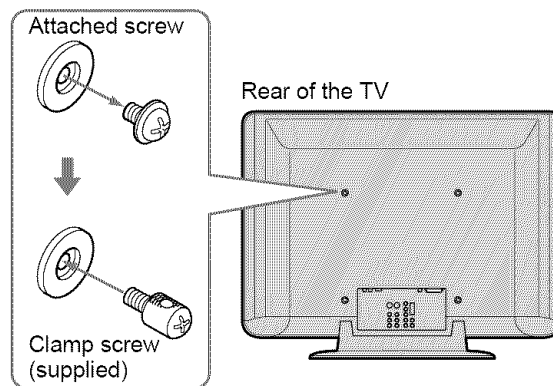

- 2** Repeat step 1 to attach the other clamp screw.
- 3** Attach a sturdy cord or chain securely to each clamp screw, and attach the cord or chain to a wall or pillar.

Connecting and Setting the TV

Basic Connections (Connecting Cable or an Antenna)

Connector types

You may find it necessary to use some of the following connector types during set up.

Supplied 75-ohm coaxial cable

Screw-on type



S VIDEO cable

High quality video cable for enhanced picture quality

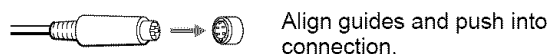

AUDIO/VIDEO cable



VIDEO - Yellow
AUDIO (Left) - White
AUDIO (Right) - Red

Some DVD players are equipped with the following three video connectors:

Y - Green
P_B (C_B, C_b or B-Y) - Blue
P_R (C_R, C_r or R-Y) - Red



Connecting directly to cable or an antenna

VHF only or VHF/UHF or cable

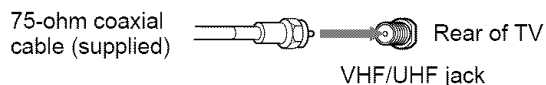

Note

It is strongly recommended to connect the antenna using a 75-ohm coaxial cable to get optimum picture quality. A 300-ohm twin lead cable can be easily affected by radio noise and the like, resulting in signal deterioration. If you use a 300-ohm twin lead cable, keep it away as far as possible from the TV.

Cable box connections

Use this hookup if:

- You subscribe to a cable TV system that uses scrambled or encoded signals requiring a cable box to view all channels, and
- You do not intend to hook up any other audio or video equipment to your TV.

- 1 Connect the coaxial connector from your cable service to the cable box's IN jack.
- 2 Using the supplied 75-ohm coaxial cable, connect the cable box's OUT jack to the TV's VHF/UHF jack.

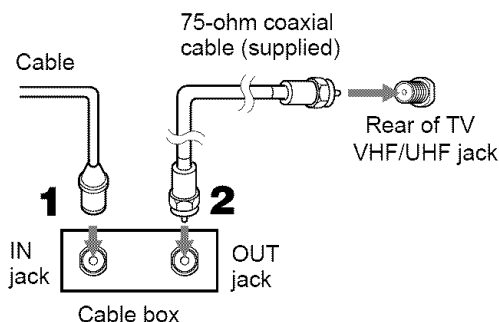

Also, set "Cable" to "On" in the  (Channel) menu (see page 36).

Tips

- The supplied remote control can be programmed to operate your cable box (see "Programming the Remote Control" on page 14).
- To change channels using the cable box, set your TV to channel 3 or 4 depending on the cable box channel output.
- If you will be controlling all channel selection through your cable box, consider using the Channel Fix feature to set your TV to channel 3 or 4 (see page 37).

Connecting Optional Equipment

Use the instructions in this section to connect the following optional equipment:

If you are connecting	See page
VCR and Cable TV	23 page
Satellite Receiver	24 page
Satellite Receiver and VCR	25 page
Audio Receiver	26 page
DVD Player with Component Video Connectors	27 page
DVD Player with S Video and Audio Connectors	28 page
Digital Cable Box	29 page
Digital Satellite Receiver	30 page
Digital Satellite Receiver with HDMI Connector	31 page
DVD Player or Digital Satellite Receiver via AV Receiver	33 page
Camcorder	34 page

Connecting the Power Cord

Complete other connections prior to connecting the power cord.

- 1 Connect the power cord to the AC IN connector of the TV.
- 2 Secure the AC power plug to the display's AC IN jack.

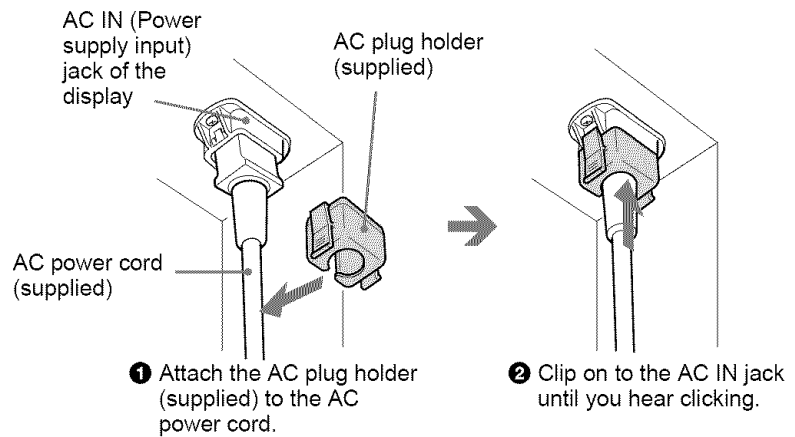

Note

When you unplug the AC power cord, drag the holder down by pushing both sides of the holder, then pull out the plug.

- 3 Connect the other plug of the power cord to a wall outlet.

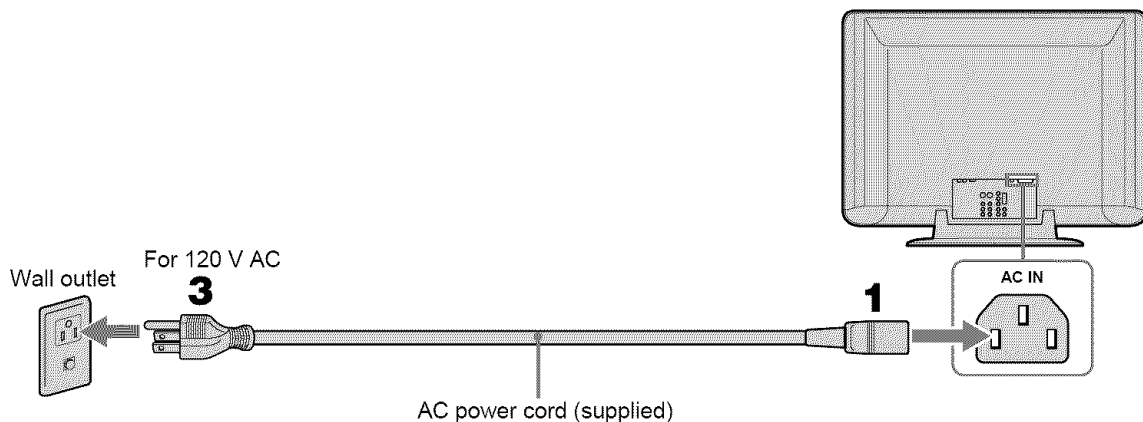

Connecting a VCR and Cable TV

Use this hookup if:

- You subscribe to a cable TV system that does not require a cable box.

Disconnect all power sources before making any connections.

- 1** Connect the CATV cable to the VCR's IN jack.
- 2** Using the supplied 75-ohm coaxial cable, connect the VCR's OUT jack to the TV's VHF/UHF jack.
- 3** Using AUDIO and S VIDEO cables, connect the VCR's AUDIO and S VIDEO OUT jacks to the TV's AUDIO and S VIDEO IN jacks (VIDEO IN 1 or 3).

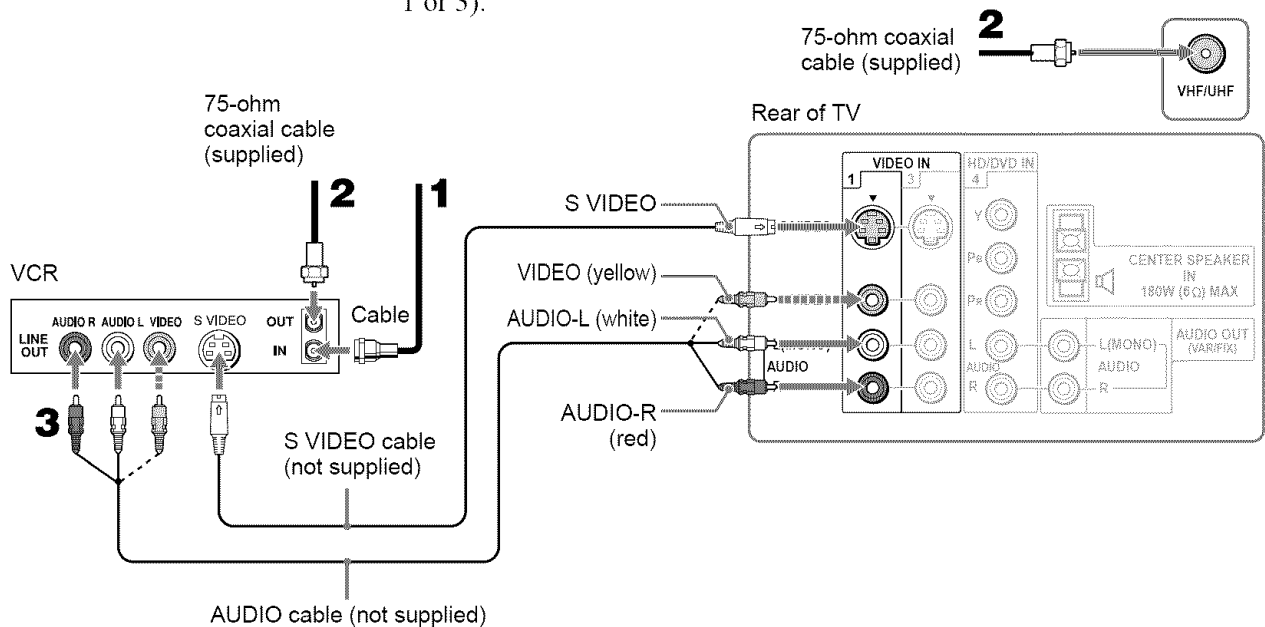

Note







When you connect video equipment to both the VIDEO and the S VIDEO input jacks, make sure "Auto YC" in the  (Setup) menu is set to "On" to view the S VIDEO input (see below).



Tips

- You can also use the VIDEO IN 2 jacks located on the front of the TV to connect your VCR.
- If your VCR is not equipped with S VIDEO, use a VIDEO cable (yellow) instead of the S VIDEO cable.

When connecting both VIDEO IN and S VIDEO IN

Using the menu, you can select the jack from which the TV receives the input signal. You can set it for each video input (VIDEO IN 1, VIDEO IN 2 and VIDEO IN 3) separately. The TV is factory set to receive S VIDEO input signals.

- 1** Press VIDEO 1/2/3 repeatedly until the desired video input appears.
- 2** Press MENU.
- 3** Press  to select  (Setup), then press .
- 4** Press  to select "Auto YC," then press .
- 5** To watch the pictures input from the S VIDEO input jack: Press  to select "On," then press .

To watch the pictures input from the VIDEO input jack:
Press  to select "Off," then press .

- 6** Press MENU to exit the menu screen.

Connecting a Satellite Receiver

Disconnect all power sources before making any connections.

- 1** Connect the satellite antenna cable to the satellite receiver's SATELLITE IN jack.
- 2** Using AUDIO and S VIDEO cables, connect the satellite receiver's AUDIO and S VIDEO OUT jacks to the TV's AUDIO and S VIDEO IN jacks (VIDEO IN 1 or 3).
- 3** Connect the supplied 75-ohm coaxial cable from your cable or antenna to the TV's VHF/UHF jack.

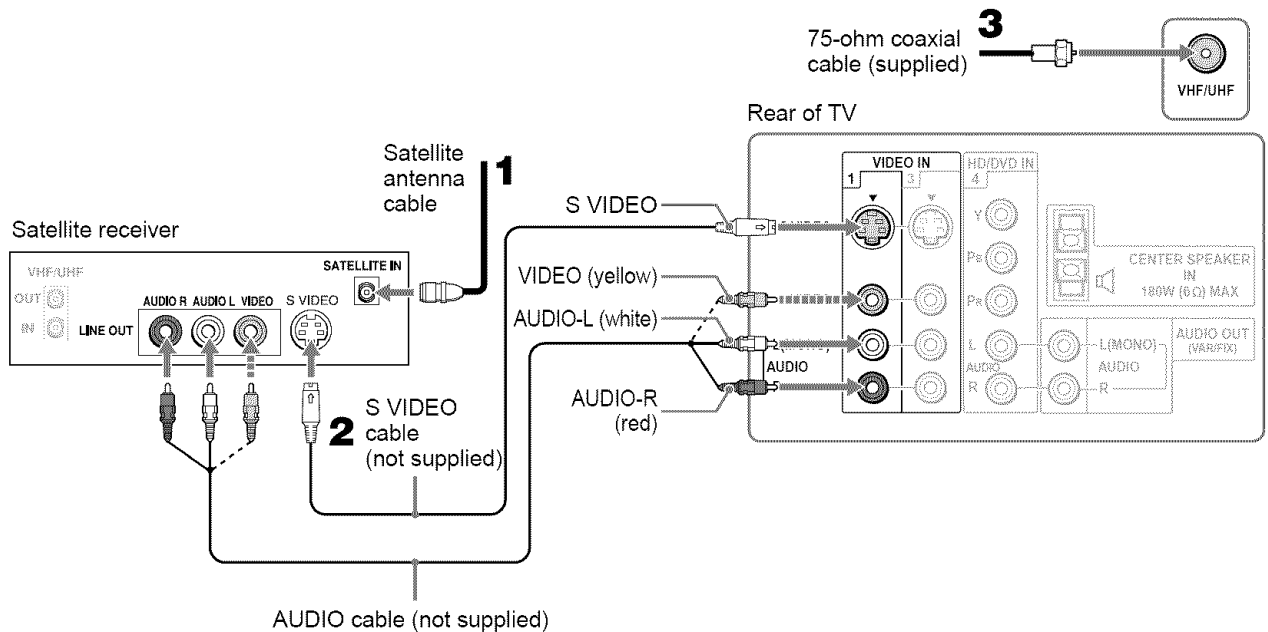

Note

When you connect video equipment to both the VIDEO and the S VIDEO input jacks, make sure "Auto YC" in the  (Setup) menu is set to "On" to view the S VIDEO input (see page 23).

Tips

- You can also use the VIDEO IN 2 jacks located on the front of the TV to connect your satellite receiver.
- If your satellite receiver is not equipped with S VIDEO, use a VIDEO cable (yellow) instead of the S VIDEO cable.
- Use VIDEO 1/2/3 on the remote control to select VIDEO IN 1 (or VIDEO IN 3 if you use the VIDEO IN 3 jacks for this hookup) to watch satellite TV.

Connecting a Satellite Receiver and a VCR

Disconnect all power sources before making any connections.

- 1** Connect the satellite antenna cable to the satellite receiver's SATELLITE IN jack.
- 2** Connect the CATV cable to the VCR's VHF/UHF IN jack.
- 3** Using the supplied 75-ohm coaxial cable, connect the VCR's OUT jack to the TV's VHF/UHF jack.
- 4** Using AUDIO and S VIDEO cables, connect the satellite receiver's AUDIO and S VIDEO OUT jacks to the VCR's AUDIO and S VIDEO IN jacks.
- 5** Using AUDIO and S VIDEO cables, connect the VCR's AUDIO and S VIDEO OUT jacks to the TV's AUDIO and S VIDEO IN jacks (VIDEO IN 1 or 3).

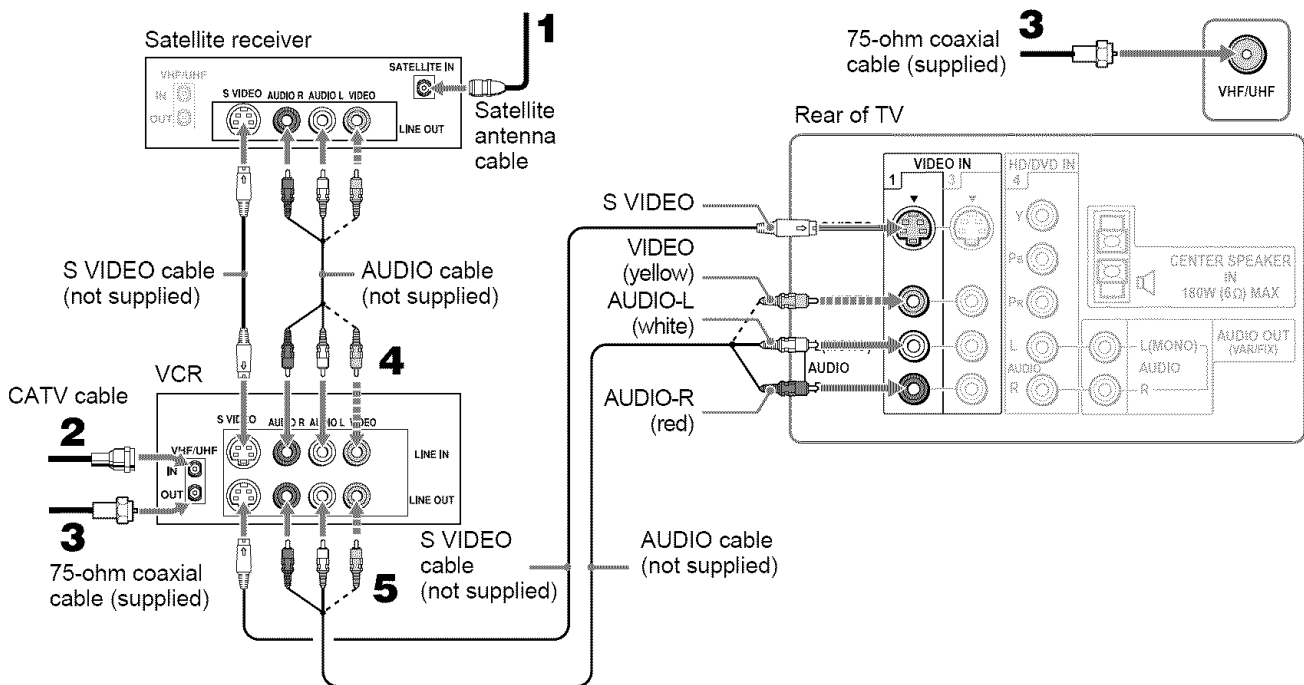

Note

When you connect video equipment to both the VIDEO and the S VIDEO input jacks, make sure "Auto YC" in the  (Setup) menu is set to "On" to view the S VIDEO input (see page 23).

Tips

- You can also use the VIDEO IN 2 jacks located on the front of the TV to connect your VCR.
- Be sure your VCR's video input is set correctly. Consult your VCR's operating manual for instructions.
- Use VIDEO 1/2/3 on the remote control to select VIDEO IN 1 (or VIDEO IN 3 if you use the VIDEO IN 3 jacks for this hookup) to watch satellite TV or to watch a tape on the VCR (your VCR must be turned on).
- If your VCR or satellite receiver is not equipped with S VIDEO, use a VIDEO cable (yellow) instead of the S VIDEO cable.

Connecting an Audio Receiver

Disconnect all power sources before making any connections.

Using an AUDIO cable, connect the TV's AUDIO OUT jacks to the audio receiver's AUDIO IN jacks.

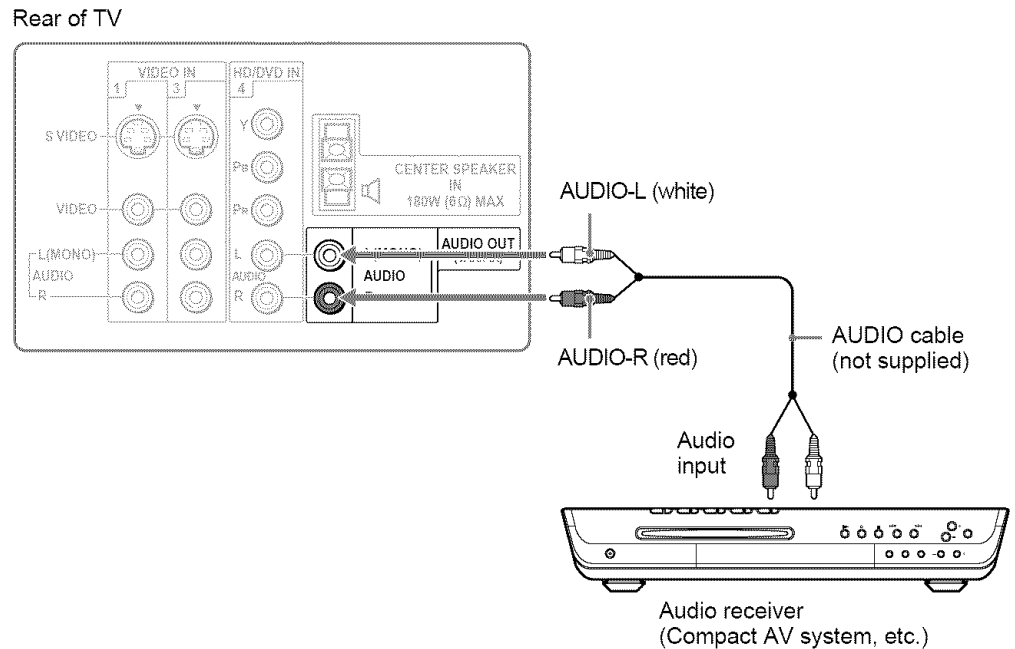

When using your audio system speakers

You can control the volume output from your audio system using the TV's remote control (see "Programming the Remote Control" on page 14), by setting "Audio Out" in the  (Audio) menu to "Variable."

If you want to adjust the volume through your audio system, set "Audio Out" to "Fixed."

Notes

- The video signal is not output through the AUDIO OUT jacks.
- When "Audio Out" in the  (Audio) menu is set to "Variable," "Speaker" is to "Off," check if the speaker volume is moderate before switching "Speaker" from "Off" to "On." Otherwise, the speaker volume may get too loud.

Connecting a DVD Player with Component Video Connectors

Use this hookup if:

- Your DVD player has component (Y, P_B, P_R) jacks.

Disconnect all power sources before making any connections.

- 1** Using a component video cable, connect the DVD player's Y, P_B and P_R jacks to the Y, P_B and P_R jacks on the TV. Use the HD/DVD IN 4 connections.

Tip

The Y, P_B and P_R jacks on your DVD player are sometimes labeled as Y, C_B and C_R, or Y, B-Y and R-Y. If so, connect the cables to the matching colors.

- 2** Using an AUDIO cable, connect the DVD player's AUDIO OUT jacks to the TV's AUDIO IN jacks.

Note

The Y, P_B and P_R jacks do not provide audio, so audio cables must be connected to provide sound.

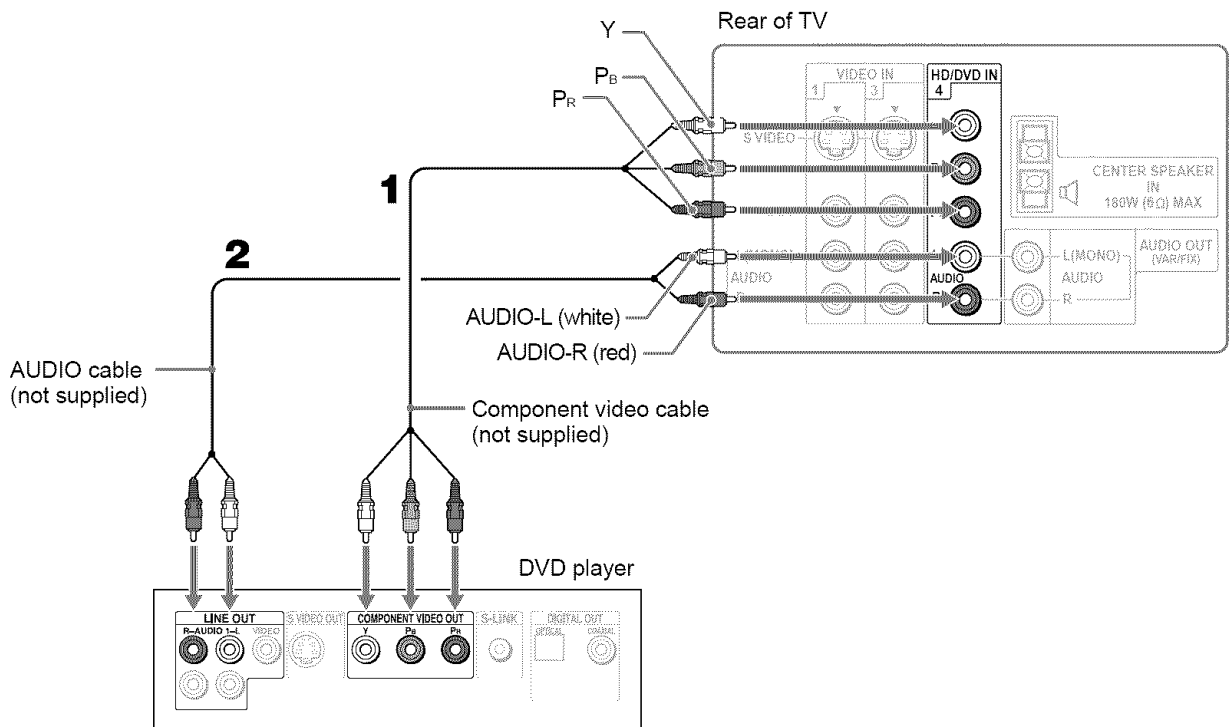

Tips

- To take advantage of the Wide Screen Modes, set the aspect ratio of the output signal to 16:9 on your DVD player. For details, refer to the operating instructions supplied with your DVD player.
- Some DVD players are equipped with the three component video connectors: Y - Green, P_B (C_B, C_b or B-Y) - Blue and P_R (C_R, C_r or R-Y) - Red.

Connecting a DVD Player with S Video and Audio Connectors

Use this hookup if:

- Your DVD player does not have component (Y, P_B, P_R) jacks.

Tip

If your DVD player has component video output connectors, for best picture quality, use the connection described on page 27.

The Y, P_B and P_R jacks on your DVD player are sometimes labeled as Y, C_B and C_R, or Y, B-Y and R-Y. If so, connect the cables to the matching colors.

Disconnect all power sources before making any connections.

- 1** Using an AUDIO cable, connect the DVD player's AUDIO OUT jacks to the TV's AUDIO IN jacks.
- 2** Using an S VIDEO cable, connect the DVD player's S VIDEO OUT jack to the TV's S VIDEO IN jack (VIDEO IN 1 or 3).

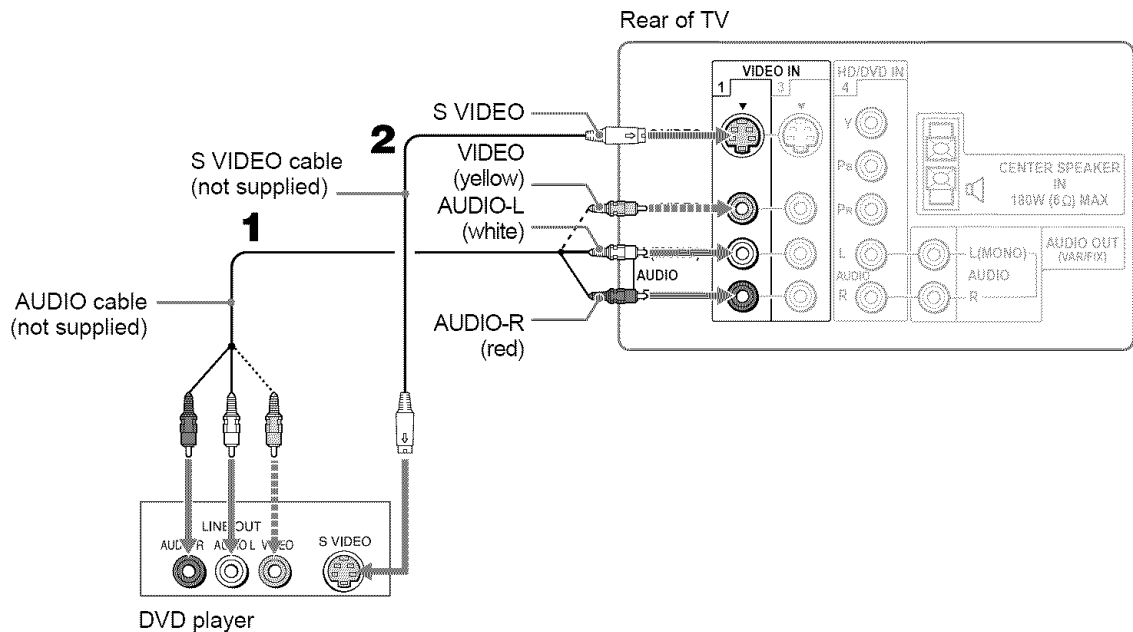

Note

When you connect video equipment to both the VIDEO and the S VIDEO input jacks, make sure "Auto YC" in the  (Setup) menu is set to "On" to view the S VIDEO input (see page 23).

Tips

- You can also use the VIDEO IN 2 jacks located on the front of the TV to connect your DVD player.
- To take advantage of the Wide Screen Modes, set the aspect ratio of the output signal to 16:9 on your DVD player. For details, refer to the operating instructions supplied with your DVD player.
- Use VIDEO 1/2/3 on the remote control to switch to the DVD player input.
- If your DVD player is not equipped with S VIDEO, use a VIDEO cable (yellow) instead of the S VIDEO cable.

Connecting a Digital Cable Box

Disconnect all power sources before making any connections.

- 1 Using a component video cable, connect the Digital Cable Box's Y, P_B and P_R jacks to the Y, P_B and P_R jacks on the TV. Use the HD/DVD IN 4 connections.

Note

Component video (Y, P_B, P_R) connection is necessary to view 480p, 720p, and 1080i formats. Note that this TV displays all format types of picture in a resolution of 852 dots × 480 lines.

- 2 Using an AUDIO cable, connect the Digital Cable Box's AUDIO OUT jacks to the TV's AUDIO IN jacks.

Note

The Y, P_B and P_R jacks do not provide audio, so audio cables must be connected to provide sound.

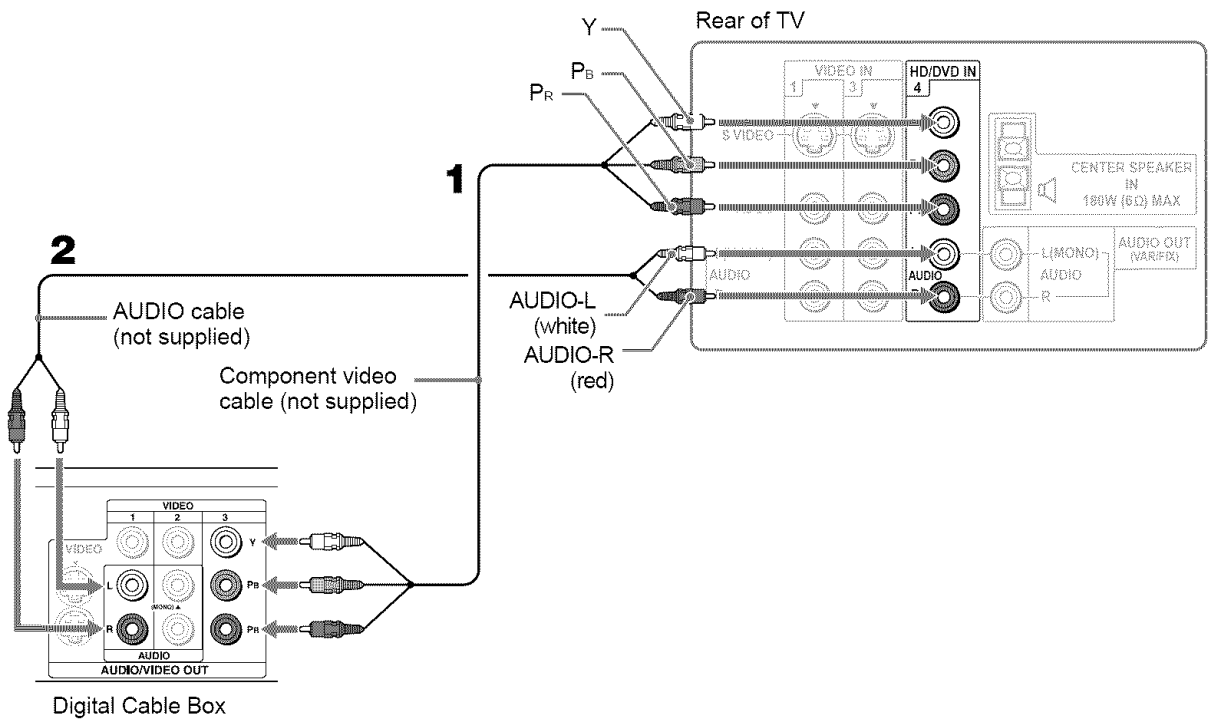

Connecting a Digital Satellite Receiver

Disconnect all power sources before making any connections.

- 1 Using a component video cable, connect the Digital Satellite Receiver's Y, P_B and P_R jacks to the Y, P_B and P_R jacks on the TV. Use the HD/DVD IN 4 connections.

Note

Component video (Y, P_B, P_R) connection is necessary to view 480p, 720p, and 1080i formats. Note that this TV displays all format types of picture in a resolution of 852 dots × 480 lines.

- 2 Using an AUDIO cable, connect the Digital Satellite Receiver's AUDIO OUT jacks to the TV's AUDIO IN jacks.

Note

The Y, P_B and P_R jacks do not provide audio, so audio cables must be connected to provide sound.

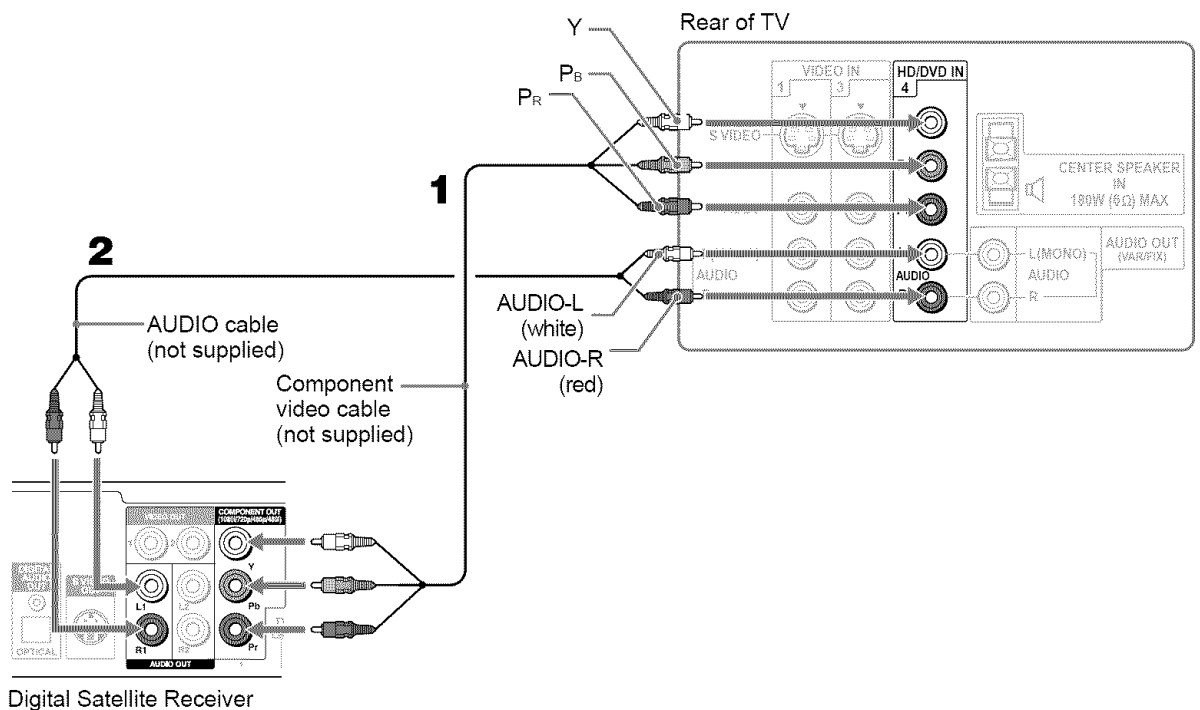

Connecting a Digital Satellite Receiver with HDMI Connector

Use this hookup if:

- Your Digital Satellite Receiver has a High-Definition Multimedia Interface (HDMI).

Disconnect all power sources before making any connections.

Using an HDMI cable (not supplied), connect the Digital Satellite Receiver's HDMI OUT connector to the TV's HDMI IN connector.

Use the HDMI IN 5 connection.

Tip

The HDMI connector provides both video and audio signals, so it is not necessary to connect the audio cable.

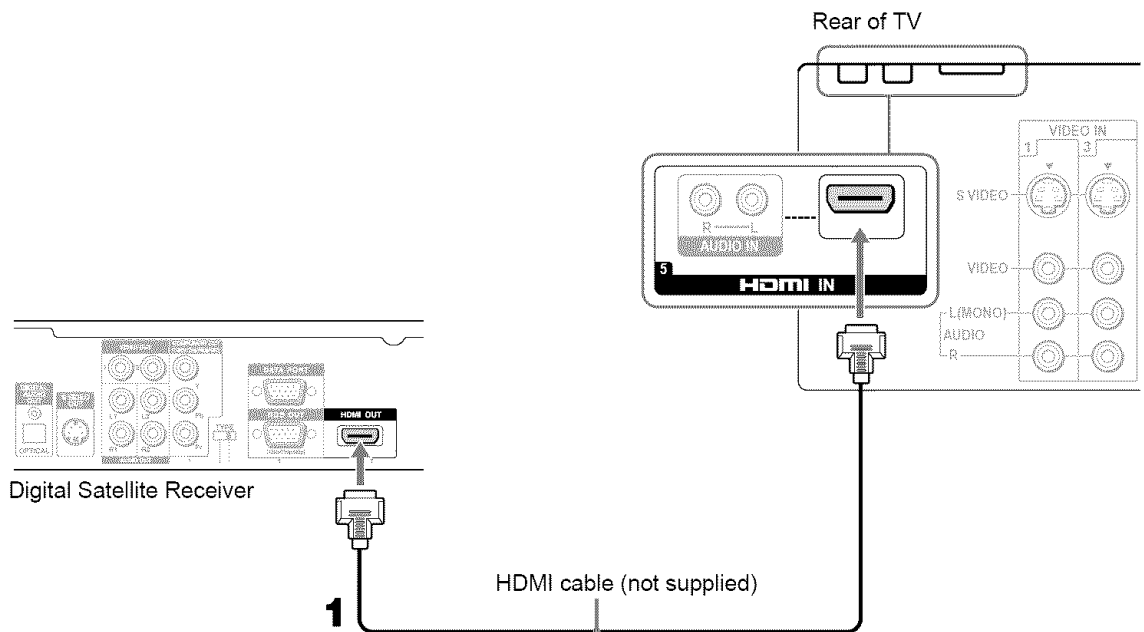

When connecting to the Digital Satellite Receiver's DVI-HDTV connector

If the Digital Satellite Receiver does not have an HDMI connector, you can connect the TV's HDMI IN connector to the Digital Satellite Receiver's DVI-HDTV OUT connector using the HDMI cable (not supplied).

- 1 Using a HDMI cable (not supplied), connect the Digital Satellite Receiver's DVI-HDTV OUT connector to the TV's HDMI IN connector.

Use the HDMI IN 5 connection.

Note

The DVI-HDTV VIDEO connector does not provide audio, so audio cables must be connected to provide sound when an HDMI to DVI-HDTV adapter is used.

- 2 Using an AUDIO cable, connect the Digital Satellite Receiver's AUDIO OUT jacks to the TV's AUDIO IN jacks.

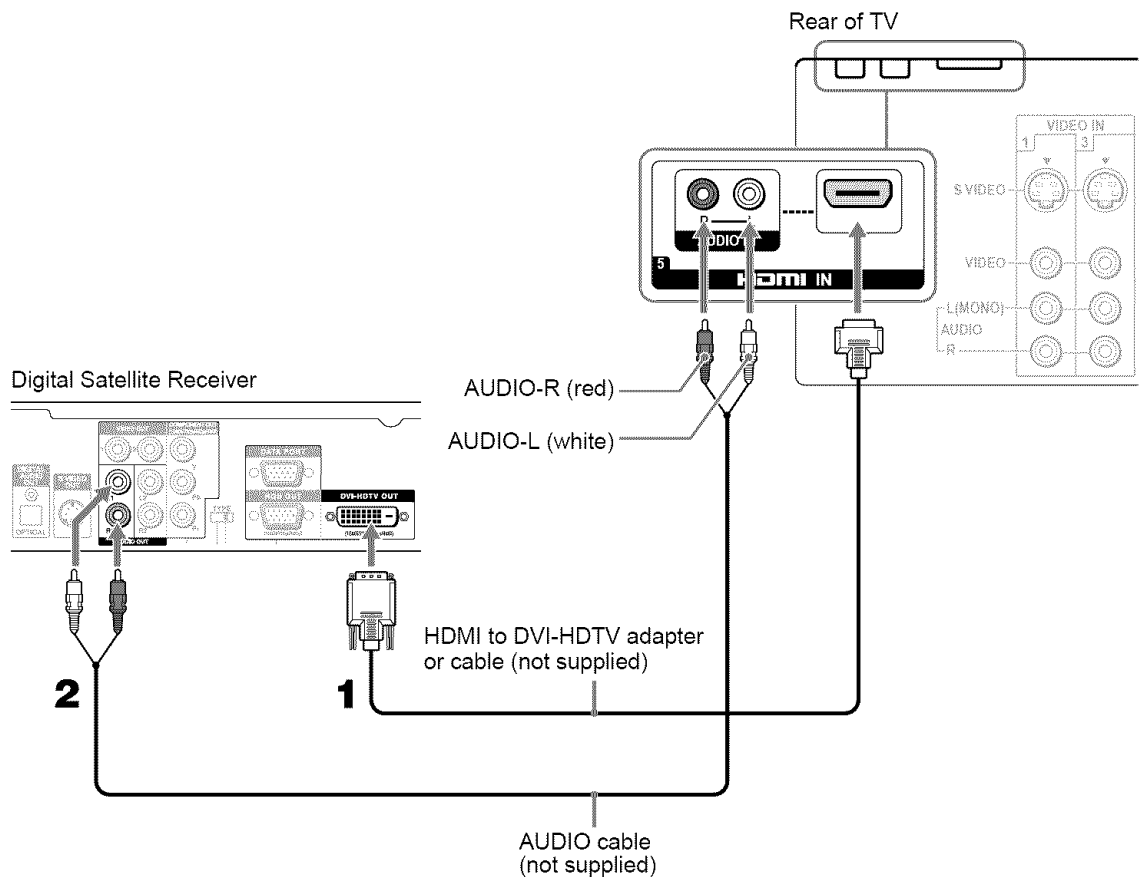

Connecting a DVD Player or Digital Satellite Receiver via AV Receiver with CENTER SPEAKER IN terminals

Use this hookup if:

- You have a digital audio device that is PCM/Dolby Digital compatible, such as an AV Receiver with a Dolby Pro Logic system decoder.

Disconnect all power sources before making any connections.

- 1** Using a SPEAKER cord, connect the TV's CENTER SPEAKER IN terminals to the AV Receiver's CENTER SPEAKER OUT terminals.
- 2** Using a component video cable, connect the DVD player or Digital Satellite Receiver's Y, P_B and P_R jacks to the Y, P_B and P_R jacks on the TV. Use the HD/DVD IN 4 connections. Using an AUDIO cable, connect the DVD player or Digital Satellite Receiver to the TV's AUDIO IN jacks.

Tips

- If your DVD player does not have component (Y, P_B, P_R) jacks, you can connect the DVD player with A/V connectors, use the connection described on page 28.
- If your Digital Satellite Receiver has a DVI-HDTV or HDMI connector, for best picture quality, use the connection described on page 31.

- 3** Using an optical digital cable, connect the DVD player or Digital Satellite Receiver's OPTICAL OUT jack to the AV Receiver's OPTICAL IN jack.

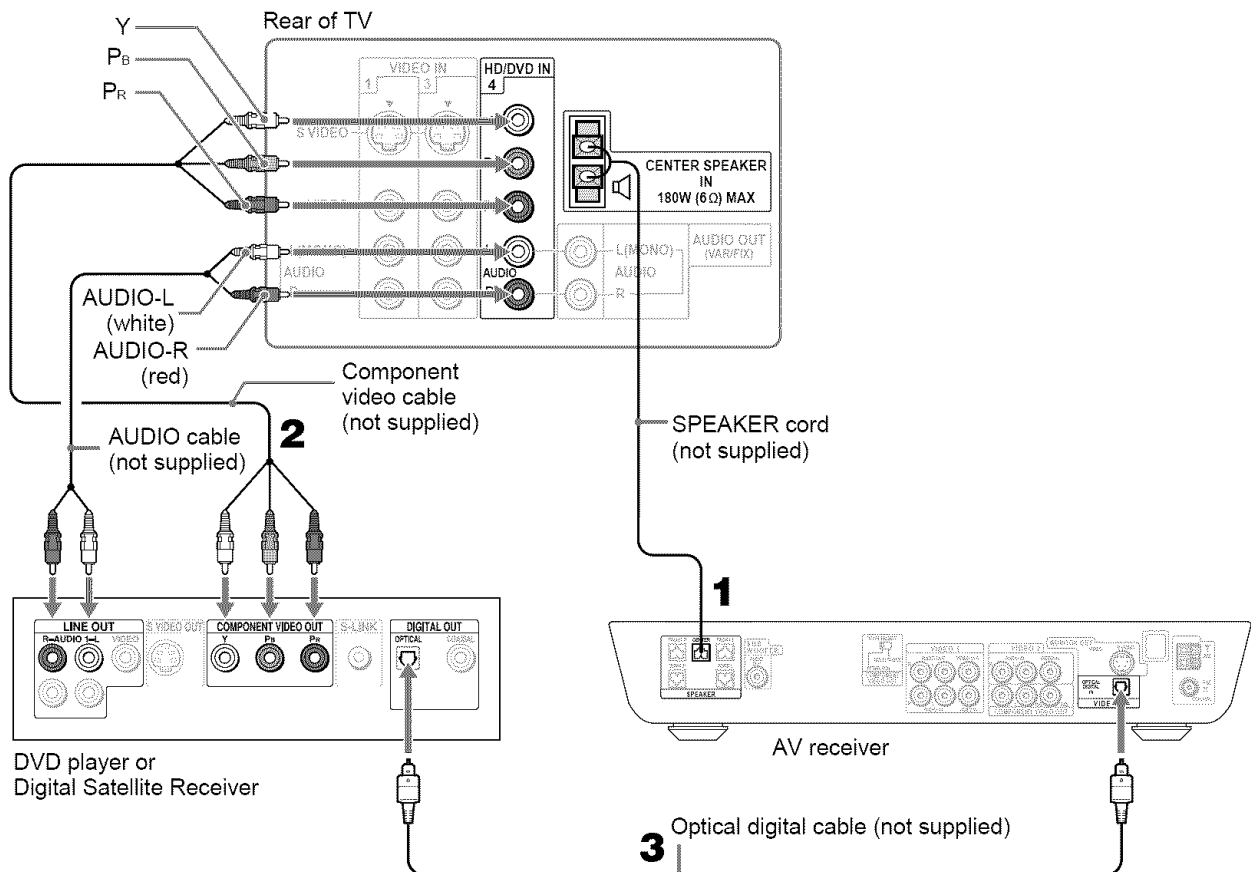

When using the TV's speakers as the center speaker

Using “Center Speaker Mode” in (Audio) menu, select the video input that you want to use the TV's speakers as the center speaker, and set to “On.” For more details, see “Using the Center Speaker Feature” on page 49.

Connecting a Camcorder

Disconnect all power sources before making any connections.

Using an A/V cable, connect the Camcorder's A/V OUT jack to the TV's AUDIO IN jacks and VIDEO IN jack (VIDEO IN 2).

Tip

You can also use the VIDEO 1 and 3 jacks located on the rear of the TV to connect your camcorder.

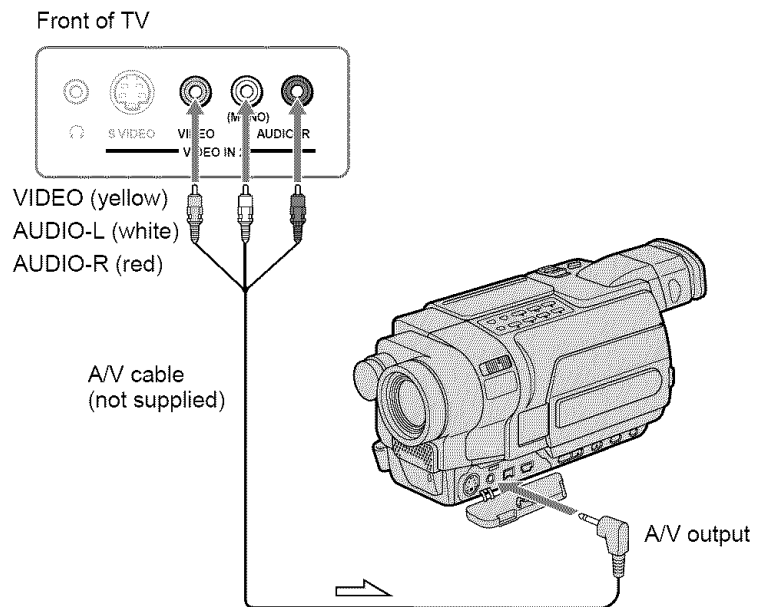

Setting the TV

Setting the Channels

After you finish connecting your TV, you can run Auto Program to set up your channels. The Auto Setup menu appears when you turn your TV on for the first time after installing it. To skip channels, see page 36.

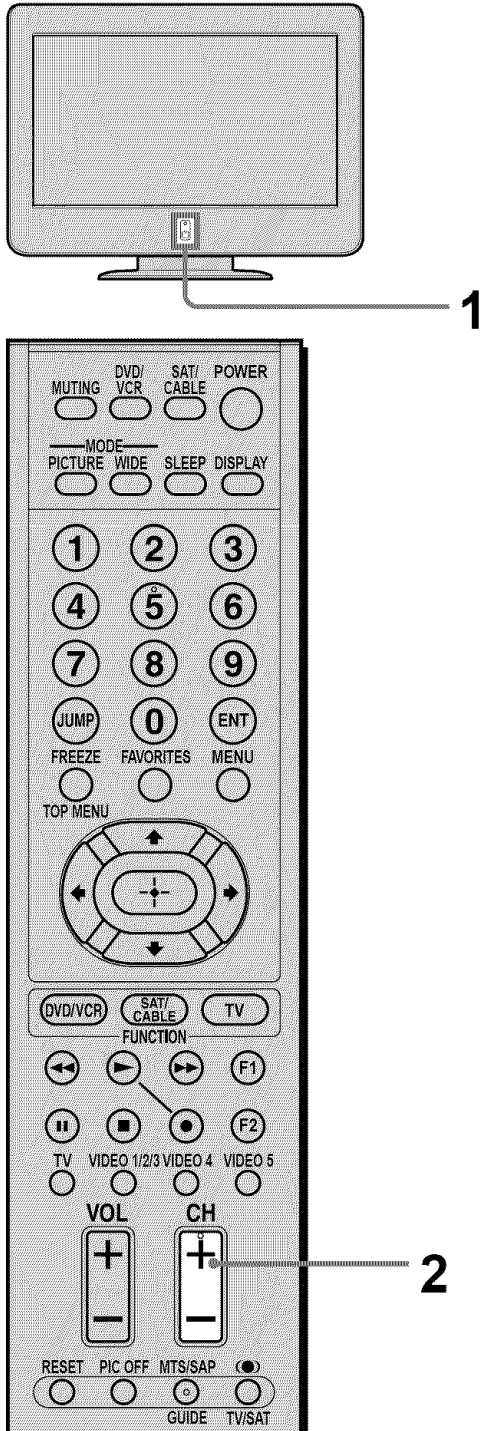

- 1 Press (Power) on the TV.

The Auto Setup menu automatically appears on the screen when you turn on the TV for the first time.

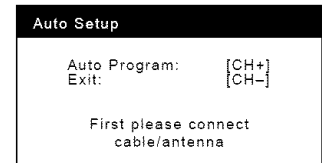
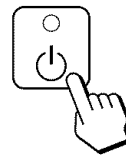

- 2 Press CH+ on the remote control or on the drop down panel of your TV to perform Auto Program.

When all the receivable channels are stored, the "Channel Skip/Add" menu appears.

Auto Program is set to scan cable TV channels by default. To watch VHF/UHF channels with an antenna, see "To watch VHF/UHF channels with an antenna" on page 36.

To perform Auto Program again

- 1 Press MENU.
- 2 Press to select (Channel), then press .
- 3 Press to select "Auto Program," then press .
- 4 Press "OK."

"Auto Program" appears and the TV starts scanning and presetting channels automatically. When all the receivable channels are stored, the "Channel Skip/Add" menu appears. Using this menu, you can start skipping unwanted channels (see "To skip channels" on page 36).

- 5 Press MENU to exit the menu screen.

To cancel Auto Program





While "Auto Program" is displayed in step 3, press MENU on the remote control.

Note

To watch cable TV channels, you have to subscribe to a cable TV company. Note that cable TV cannot be received in some areas. This TV receives 1-125 cable TV channels. For details on cable TV subscription, consult your nearest cable TV company.

(Continued)

To watch VHF/UHF channels with an antenna

- 1 Press MENU.
- 2 Press \uparrow/\downarrow to select  (Channel), then press .
- 3 Press \uparrow/\downarrow to select "Cable," then press .
- 4 Press \uparrow/\downarrow to select "Off," then press .
- 5 Perform steps 3 - 5 in "To perform Auto Program again" above.

Note



You cannot receive and set the cable TV channels and VHF/UHF channels at the same time.

Tip

When you have a cable box or satellite receiver connected, the Channel Fix feature is useful. For details, see page 37.

To skip channels

You can skip unnecessary channels when selecting channels using the CH +/- buttons.

- 1 Press MENU.
- 2 Press \uparrow/\downarrow to select  (Channel), then press .
- 3 Press \uparrow/\downarrow to select "Channel Skip/Add," then press .

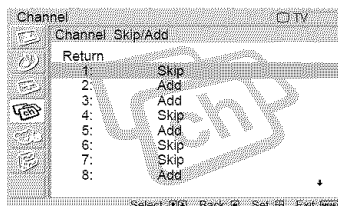

- 4 Press \uparrow/\downarrow to select the channel you want to skip, then press .

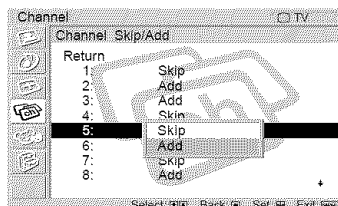

Example: Select this to skip channel 5.

Tip

To scroll through the list, press and hold \uparrow/\downarrow .

- 5 Press \uparrow/\downarrow to select "Skip," then press .

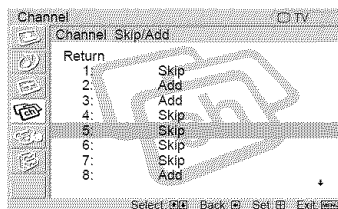

If you want to re-enter the skipped channel, select "Add."

- 6 Press MENU to exit the menu screen.

To fix in a TV channel

If you have connected a cable box or satellite receiver to your TV, and do not intend to connect any other audio or video equipment, it is recommended that you fix a TV channel. Doing so will ensure no accidental channel switch when using your TV.

- 1 Press MENU.
- 2 Press \uparrow/\downarrow to select  (Channel), then press \oplus .
- 3 Press \uparrow/\downarrow to select "Channel Fix," then press \oplus .

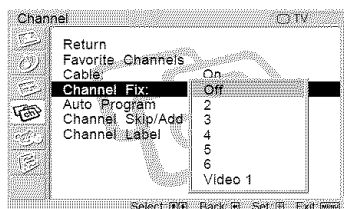

- 4 Press \uparrow/\downarrow to select the channel you want to set, then press \oplus .

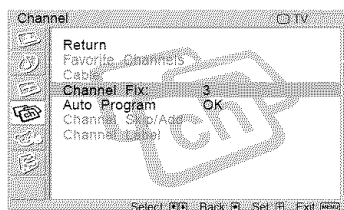

Option	Description
2-6	Select one of these channels if you have connected the equipment to the VHF/UHF jack.
Video 1	Select this if you have connected the equipment to the VIDEO IN 1 jacks.
Off	Select this to turn off the Channel Fix feature.

- 5 Press MENU to exit the menu screen.

Notes

- When you fix a TV channel, the Favorite Channel feature cannot be used.
- When you fix a TV channel, you cannot select "Channel Skip/Add" in the menu. To use it, set "Channel Fix" to "Off."

Using the Menu

Most of advanced settings and adjustments are performed using the menu screen. Basic operations to navigate through menus are described below.

- Items which appear in yellow are selected.
- You cannot select items which appear in pale color.

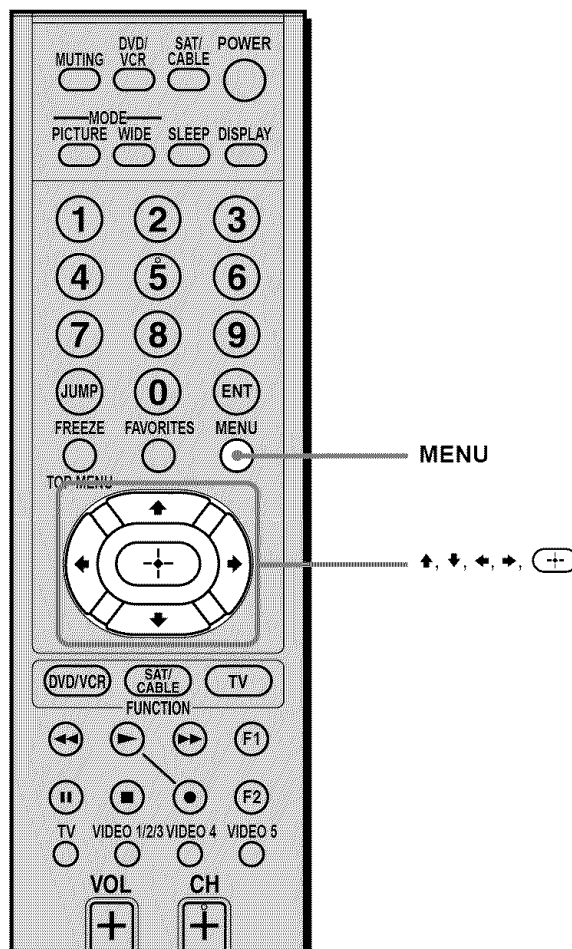

(Continued)

To open the menu screen and select the option

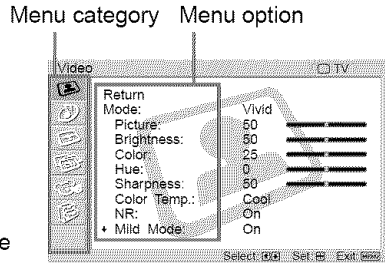

Press MENU to open the menu screen.

Press \uparrow/\downarrow to select the desired category, then press \rightarrow .

To exit the menu screen, press MENU again.

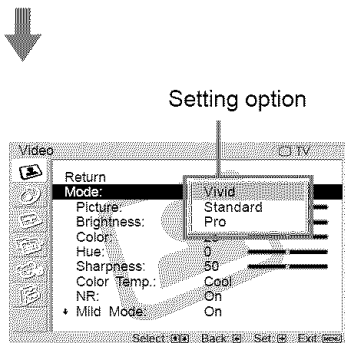
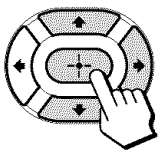

Press \uparrow/\downarrow to select the option, then press \rightarrow or \rightarrow .

(The \rightarrow button cannot be used on some menus.)

(Example: when selecting "Mode" in the (Video) menu)

To adjust the setting

Maximize the setting value

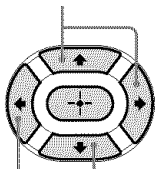

Minimize the setting value

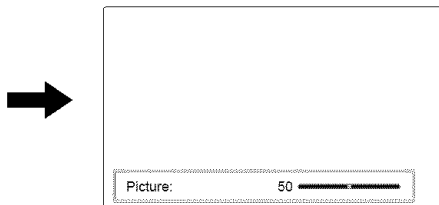

(Example: when selecting "Picture" in the (Video) menu)

Selecting the On-screen Menu Language

You can select the language to be displayed in all menus.

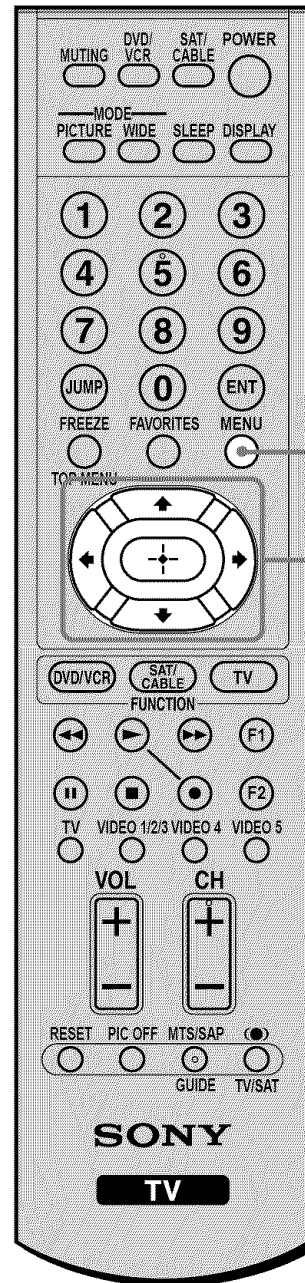

1 Press MENU.

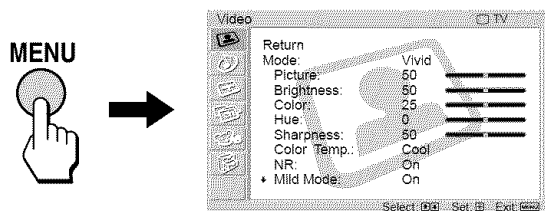

2 Press \uparrow/\downarrow to select  (Setup), then press \oplus .

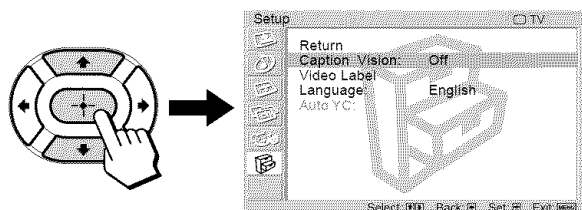

3 Press \uparrow/\downarrow to select "Language," then press \oplus .

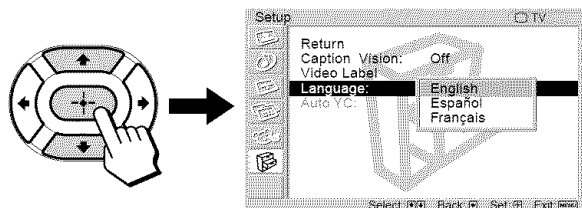

4 Press \uparrow/\downarrow to select your preferred language, then press \oplus .

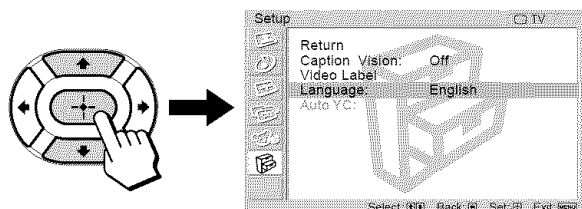

5 Press MENU to exit the menu screen.

Watching the TV

Watching the TV

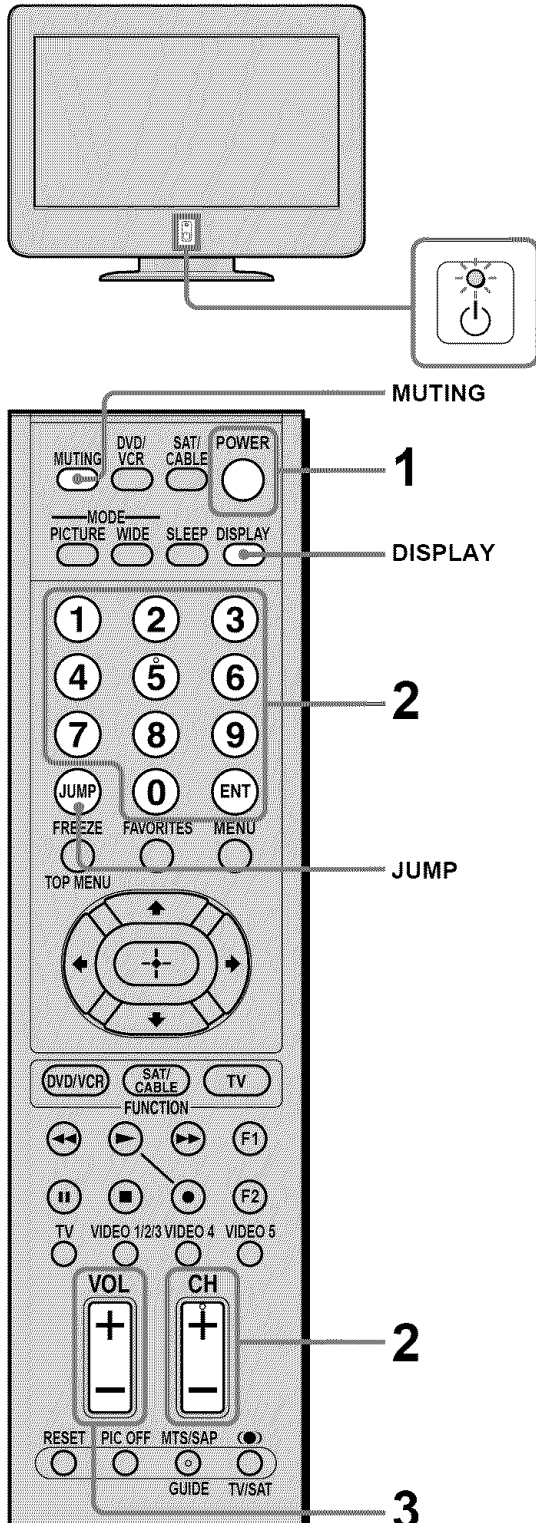



- 1 Press POWER on the remote control.

POWER



Tip

When the  (Power on/Stand by) LED goes off, press  (Power) on the TV.

- 2 Select the desired channel using the 0-9 and ENT (enter) buttons.

Press 0-9 to select a channel. The channel changes after 2 seconds. Press ENT (enter) to select immediately.

Use the CH +/- buttons to scan through the channels.

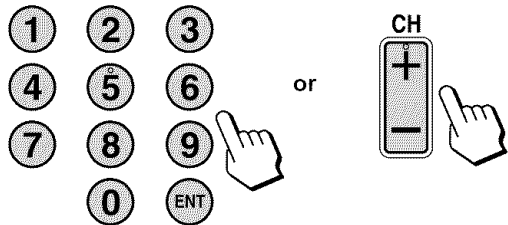

Tip

When you press and hold CH + or -, the channel number will change rapidly.

- 3 Adjust the volume using the VOL +/- buttons.

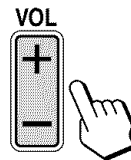

Other button operations

Press	To
MUTING	Mute the sound. Press it again or press VOL + to restore sound.
DISPLAY	Press once to display the current channel number, and channel label. If set, the current channel number will display for 10 seconds.
JUMP	Jump back and forth between two channels. The TV alternates between the current channel and the last channel selected using the 0-9 buttons.

Tip

You can adjust the volume by referring to the value beside the volume indicator (on screen).

Watching with closed caption

You can display Caption Vision if the broadcaster offers this service.

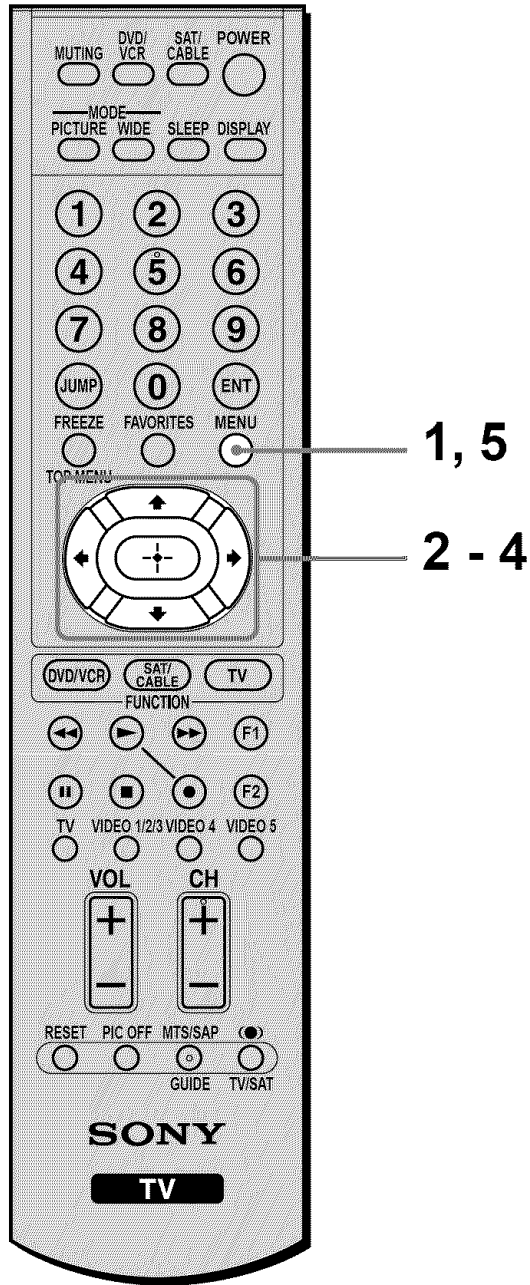

1 Press MENU.

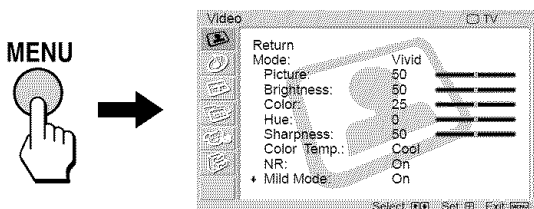

2 Press \uparrow/\downarrow to select (Setup), then press \oplus .

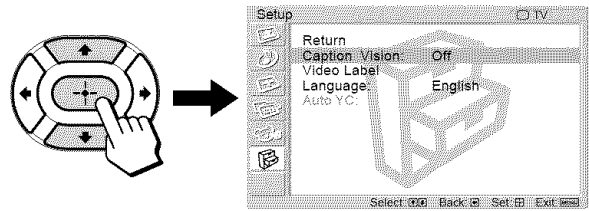

3 Press \uparrow/\downarrow to select "Caption Vision" then press \oplus .

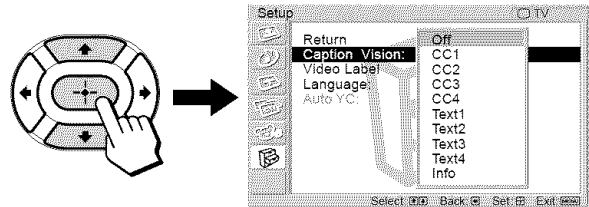

4 Press \uparrow/\downarrow to select your desired Caption Vision, then press \oplus .

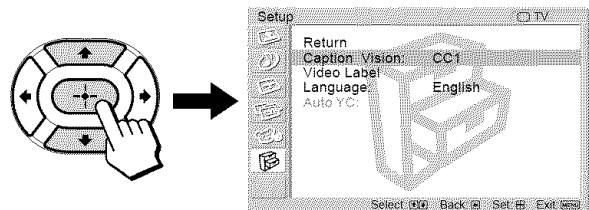

Select	To
Off	Turn off Caption Vision.
CC1, CC2, CC3, CC4	Display a printed version of the dialogue or sound effects of a program. (The mode should be set to CC1 for most programs.)
Text1, Text2, Text3, Text4	Display network/station information presented using either half or the whole screen.
Info	Displays the program name and the time remaining in the program (if the broadcaster offers this service). Displays when the channel is changed or DISPLAY is pressed.

5 Press MENU to exit the menu screen.

Note

When the TV receives 480p signal or more, "Caption Vision" cannot be selected.

Selecting the Picture Mode

You can select one of three different Picture Modes that best suits the program you are watching. Furthermore, you can adjust the picture quality for each Picture Mode (see pages 59, 60). You can set a different Picture Mode for each video input that can be selected using the Input Select buttons, and store them in memory.

Press PICTURE repeatedly until the desired mode appears.

Each time you press the button, the Picture Mode changes as follows:

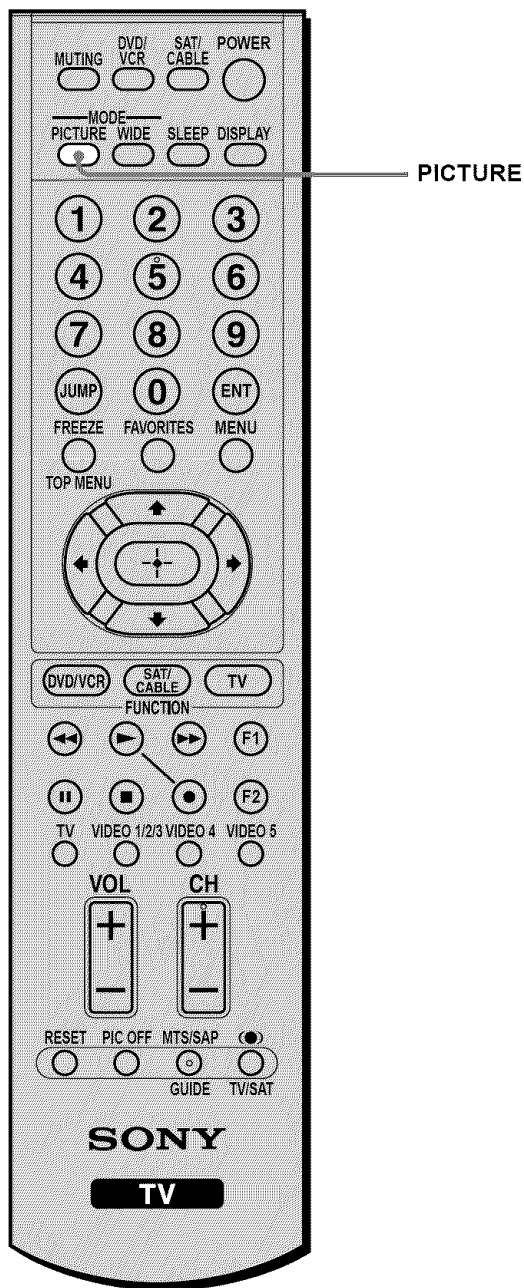
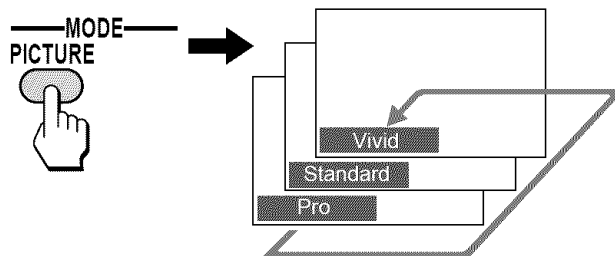

Picture Mode	Description
Vivid	Select for enhanced picture contrast and sharpness.
Standard	Select to display a picture with contrast to suit your room's lighting conditions. This mode is recommended for normal viewing conditions.
Pro	Select for professional monitor-like appearance.

Tip

You can adjust the picture quality options, such as "Picture," "Brightness," and "Color," for each Picture Mode (see pages 59, 60).

Selecting the Effect Mode

“TruSurround*” approximates the surround effect produced by a multichannel system by using the left and right speakers. You can set the Effect mode for each video input that can be selected using the Input Select buttons, and store them in memory.

* TruSurround, TruBass, SRS and the  symbol are trademarks of SRS Labs, Inc. TruSurround technology is incorporated under license from SRS Labs, Inc.

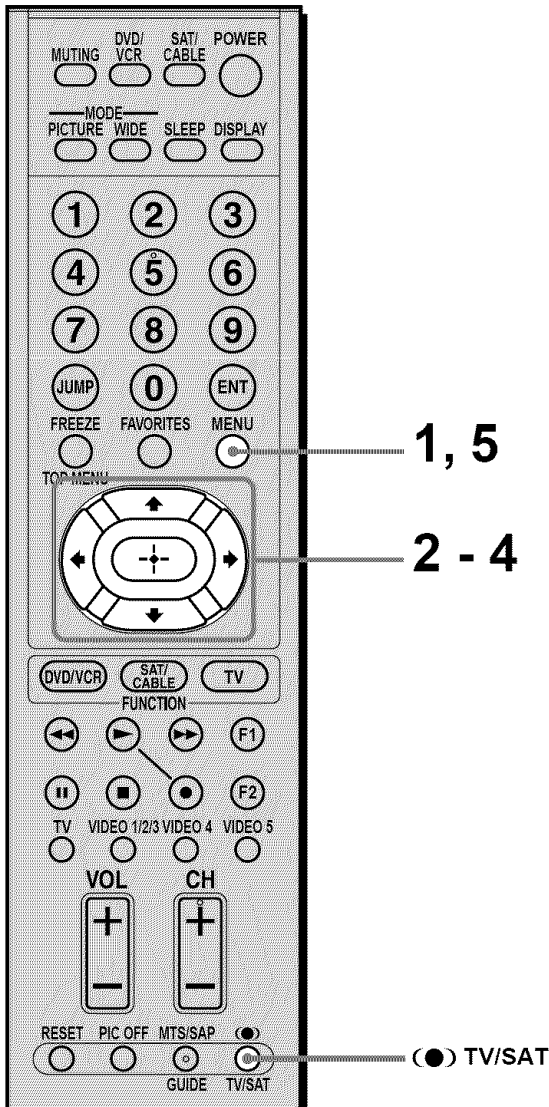

Notes

- You cannot select the Effect mode if “Speaker” in the  (Audio) menu is set to “Off.”
- The Effect mode is valid only on the TV’s speakers. So you cannot enjoy sound effects of TruSurround when you listen to a program through the AUDIO OUT jacks or on headphones.
- TruSurround may be restricted in the effects it produces when you listen to a program in monaural.

Tip

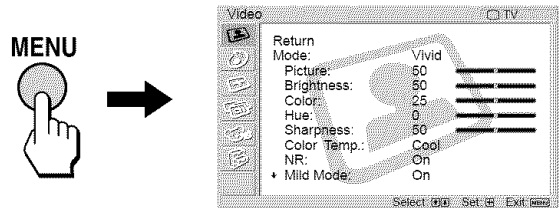

You can adjust other sound quality options. For details, see “Adjusting the Sound Quality” on page 61.

1 Press MENU.



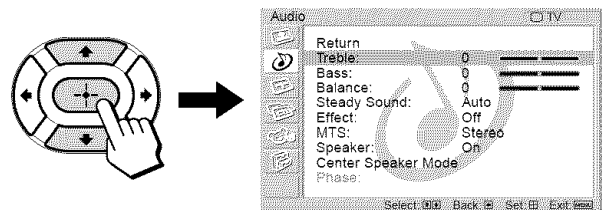

2 Press  to select  (Audio), then press .

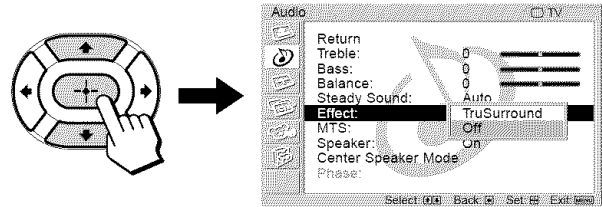

3 Press  to select “Effect,” then press .



4 Press  to select “TruSurround,” then press .

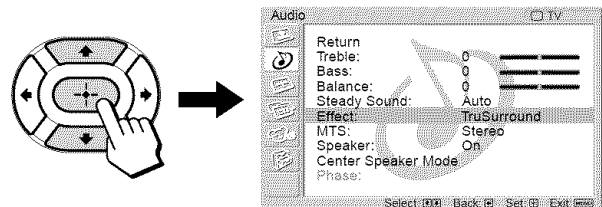

5 Press MENU to exit the menu screen.

Tip

Pressing the  TV/SAT button also lets you select “TruSurround” and “Off.”

Using the Wide Screen Mode

The Wide Screen Mode lets you watch any signals or other picture sizes such as Letterbox in several Wide Screen Modes (16:9 aspect ratio).

Tip

The “aspect ratio” is the ratio of width to height of the screen. 16:9 is also referred to as widescreen format.

Press WIDE repeatedly until the desired Wide Screen Mode appears.

Each time you press the button, the Wide Screen Mode changes as follows:

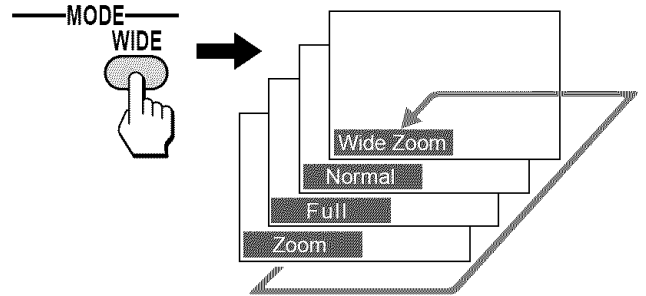

Changing the Wide Screen Mode

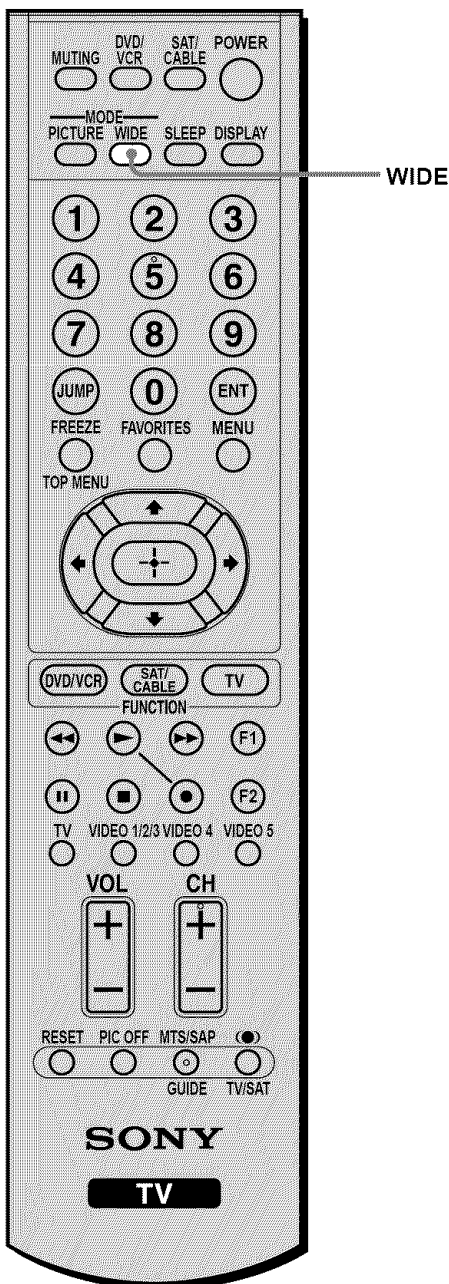

Changing the Wide Screen Mode

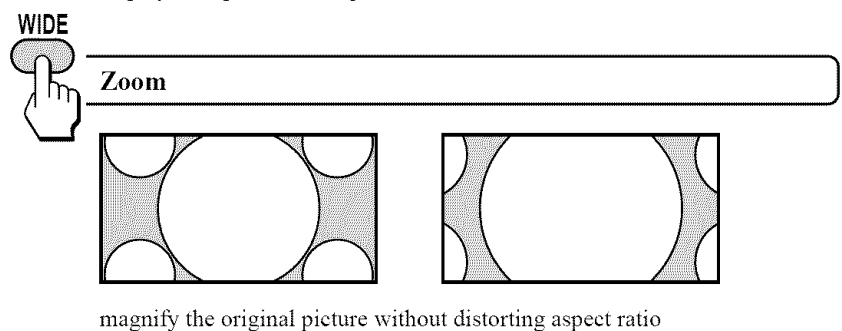
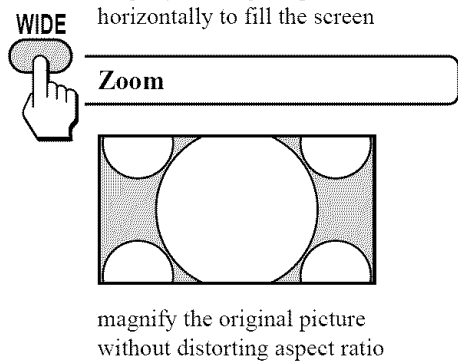
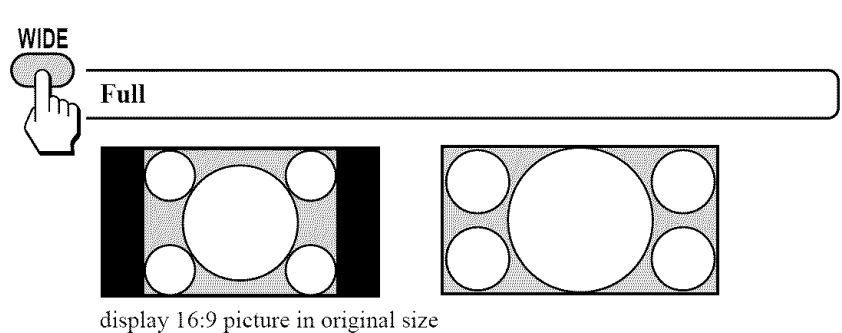
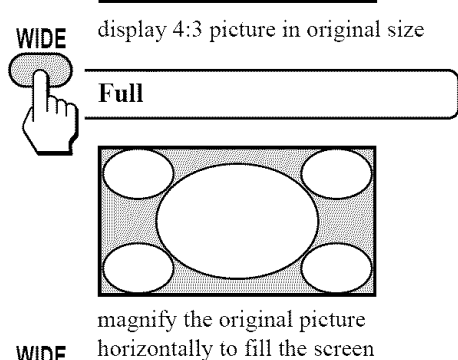
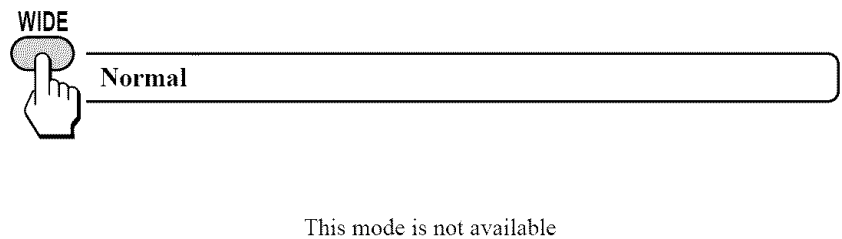
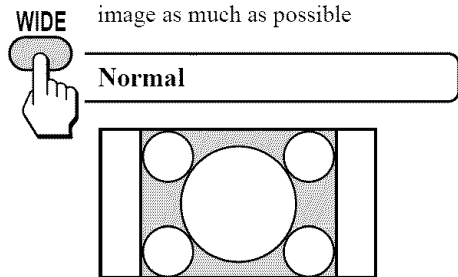
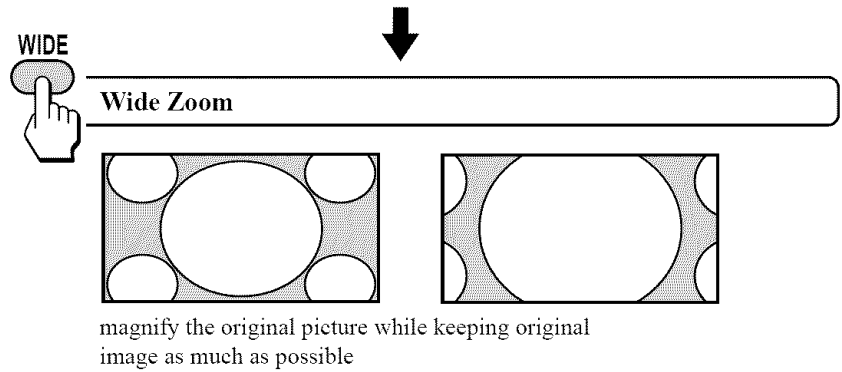
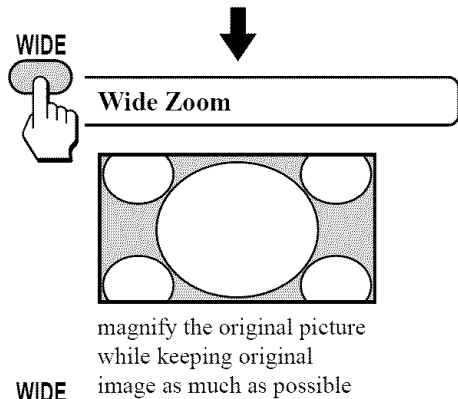
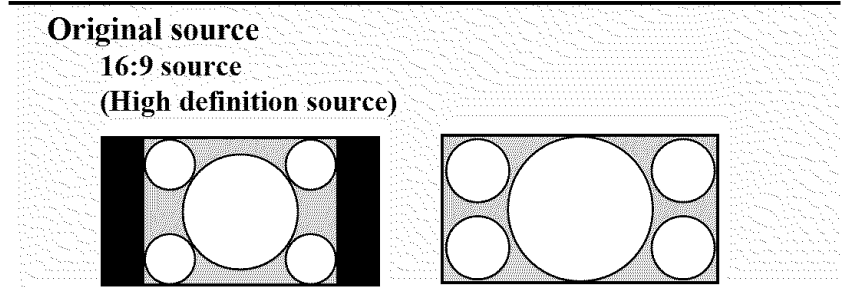
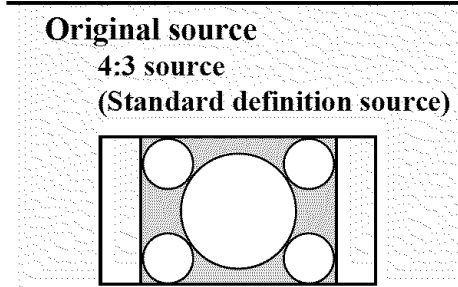

Note

When the TV receives a 720p or 1080i signal, "Normal" cannot be selected.

Tips

- When the TV receives a 720p or 1080i signal that is 4:3 aspect ratio picture with a black bar at each side, "Full" returns the picture to its original size.
- You can also access the Wide Screen Mode settings in the (Screen) menu. For details, see page 46.

Changing the Wide Screen Mode using the menu

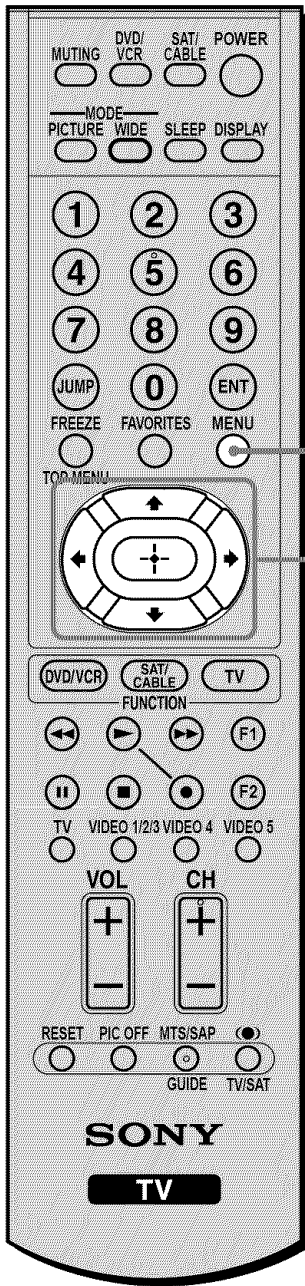

1 Press MENU.

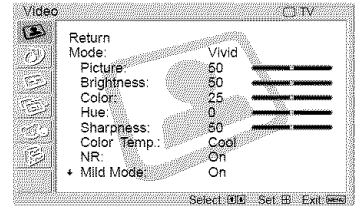

2 Press \uparrow/\downarrow to select  (Screen), then press .

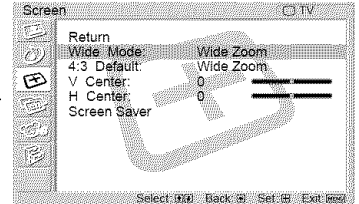
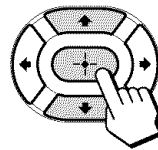

3 Press \uparrow/\downarrow to select the option you want to set, then press .

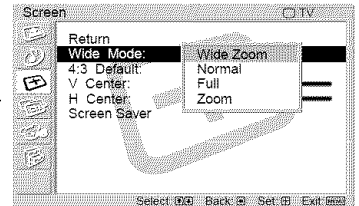
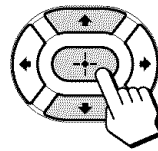

4 Press \uparrow/\downarrow to select the desired screen mode, then press .

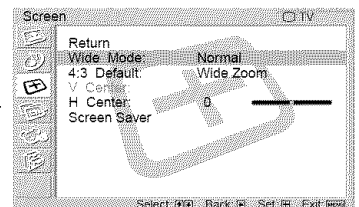
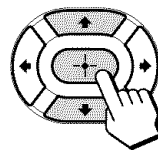

5 Press MENU to exit the menu screen.

The Wide Screen Mode options available in the (Screen) menu

Option		Description
Wide Mode Select a Wide Mode to use for 4:3 sources.	Wide Zoom	Select to magnify the original picture while keeping original image as much as possible.
	Normal	Select to display 4:3 picture in original size when the original source is 4:3 (Standard definition source).
	Full	Select to magnify the original picture horizontally to fill the screen when the original source is 4:3 (Standard definition source). When the original source is 16:9 (High definition source), select this mode to display 16:9 picture in original size.
	Zoom	Select to magnify the original picture without distorting the aspect ratio.
4:3 Default Select the default Screen Mode to use for 4:3 sources.	Wide Zoom	Select to enlarge the 4:3 picture to fill the 16:9 screen, keeping the original image as much as possible.
	Normal	Select to return the 4:3 picture to its original size.
	Full	Select to enlarge the 4:3 picture horizontally only, to fill the 16:9 screen.
	Zoom	Select to enlarge the 4:3 picture horizontally and vertically to an equal aspect ratio that fills the 16:9 screen. Useful for watching Letterbox movies.
	Off	Select to continue using the current Wide Screen Mode setting when the channel or input is changed.

Tip

To change from one Wide Screen Mode to another, use the WIDE button on the remote control.

Notes

- The 4:3 Default functions only when the TV receives 480i or 480p signals.
- If “4:3 Default” is set to anything but “Off,” the Wide Screen Mode setting changes only for the current channel. When you change channels (or inputs), the Wide Screen Mode is automatically replaced with the 4:3 Default setting. To retain the current Wide Screen Mode setting as channels and inputs are changed, set “4:3 Default” to “Off.”

Notes on the Wide Screen Mode

- The Wide Screen Mode function of this TV allows for various display options: select the appropriate Wide Screen Mode for the original aspect ratio of the picture you are watching.
- If you change the screen size using the Wide Screen Mode feature with the TV installed in a public space for commercial use or public purpose, it might be an infringement of copyright.
- If you select “Wide Zoom” when watching the picture with 4:3 aspect ratio, part of the picture is transformed. You can watch the picture with its original aspect ratio in “Normal” mode.
- The upper and lower parts of the picture may not appear in the screen according to the size of the original picture. In this case, adjust the picture position (see pages 57, 58).

Using the Freeze Function

You can use this feature to write down information such as phone numbers, recipes, etc.

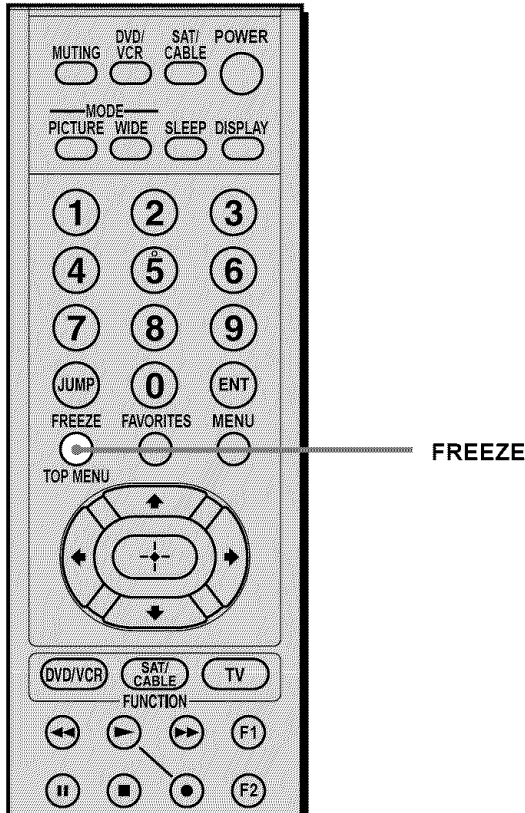

When the program information you want to capture is displayed, press FREEZE.
The picture freezes. Press FREEZE again, and the frozen picture is released, and the picture begins to move again.

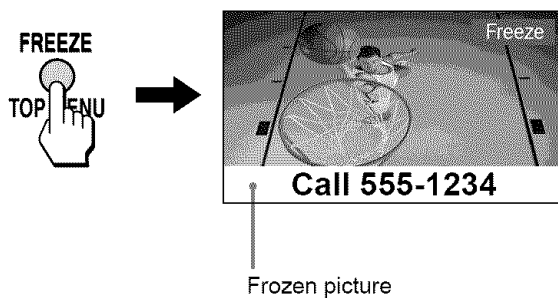



Tips

- While the picture is frozen, the sound continues to be output normally.
- The frozen picture is released after 5 minutes.

Using the Picture Off Function

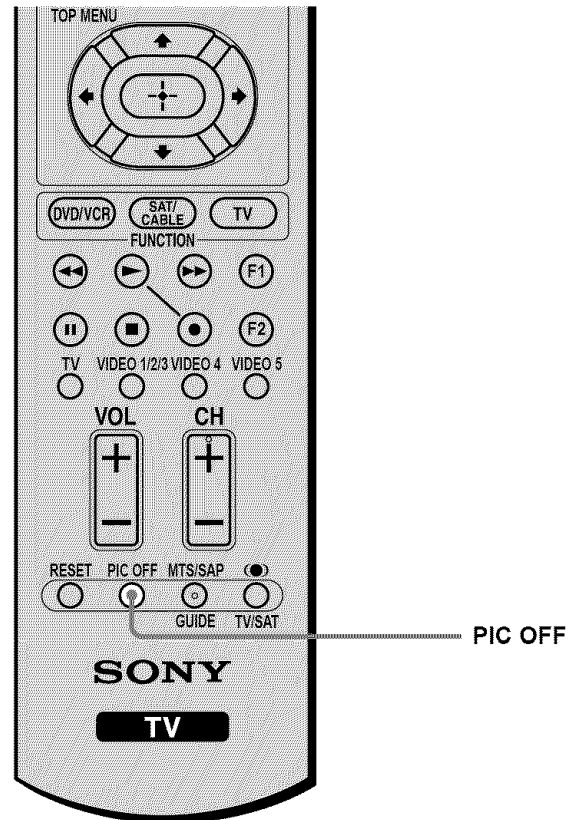
The Picture Off function lets you enjoy music from radio programs or digital broadcasts or DVDs with the TV screen turned off.



Press PIC OFF.
The  (Picture off) LED lights up in blue and the screen turns off.



To cancel and return to normal viewing, press any button except for VOL +/-, POWER, MUTING, MTS/SAP, and Effect.

Using the Center Speaker Feature

You can use the TV's speakers as the center speaker of your audio system and control its sound volume from the remote control of the TV.

Setting the Center Speaker Mode

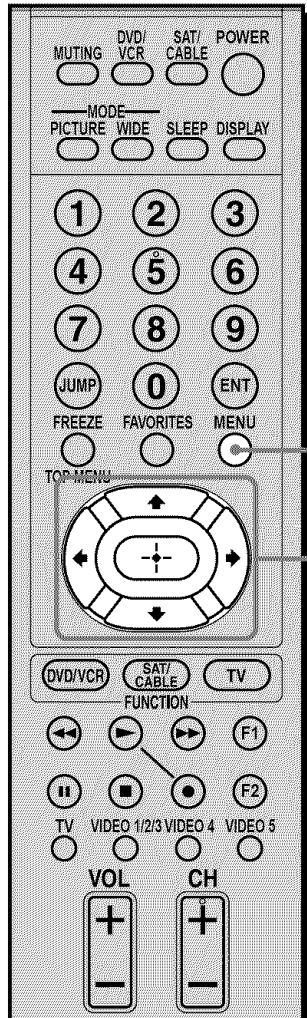

1 Press MENU.

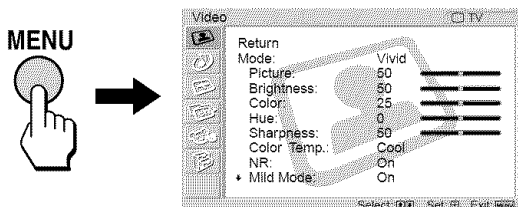

2 Press \uparrow/\downarrow to select (Audio), then press \ominus .

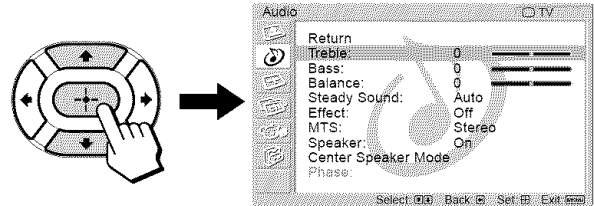

3 Press \uparrow/\downarrow to select "Center Speaker Mode" then press \ominus .

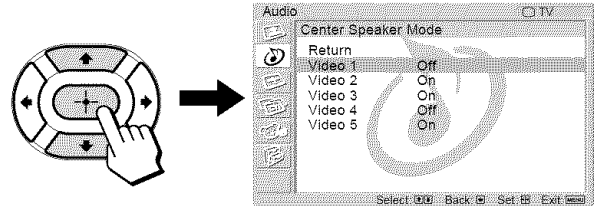

4 Press \uparrow/\downarrow to select the video input (Video 1-5) you want to use the TV's speakers as the center speaker, then press \ominus .

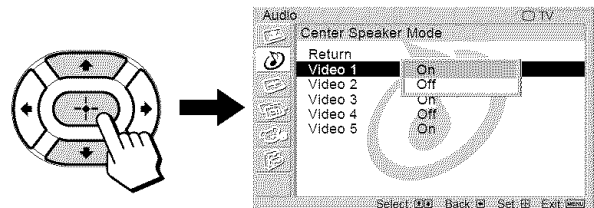

5 Press \uparrow/\downarrow to select "On," then press \ominus .

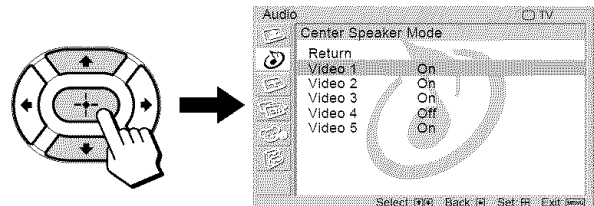

6 Press MENU to exit the menu screen.

To return to the normal speaker mode

Select "Off" in step 5 above.

Note

When "Center Speaker Mode" is set to "On," "Treble," "Bass," "Balance," "Steady Sound," "Effect," "MTS," "Speaker," and "Audio Out" cannot be selected.

Listening to the center speaker sound from the TV's speakers

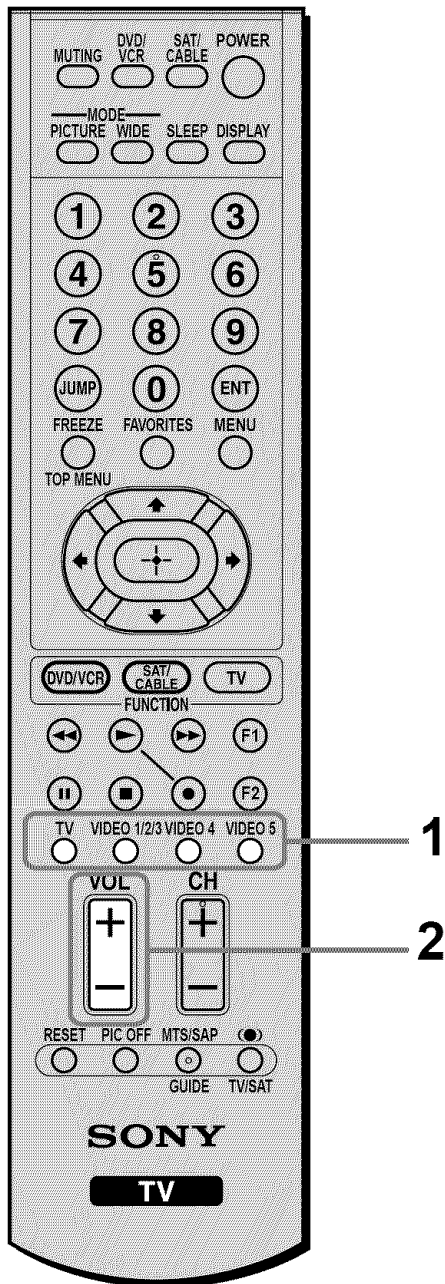

- 1 Press the input select buttons (VIDEO 1/2/3, VIDEO 4 or VIDEO 5) to select the video input selecting “Center Speaker Mode.”

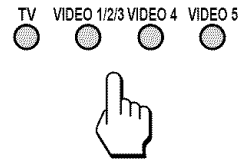

- 2 Press VOL +/- to adjust the volume of the center speaker sound from the TV's speakers.

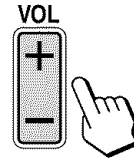

Note

If nothing is connected to the TV's CENTER SPEAKER IN terminals or if the sound source emitted from the amplifier does not contain the center speaker channel, no sound is heard from the TV's speakers.

Tip

When you want to fine tune the volume of the center speaker sound from the TV's speaker according to the input source (Video input 1,2,3,4 and 5) and your preference, follow the above steps.

Adjusting the phase of the sound

You can adjust the phase of sound when using the TV's speakers as the center speaker. If sound from the TV's speakers (as the center speaker) sound unnatural, select "Reverse."

Note

Default setting is "Normal."

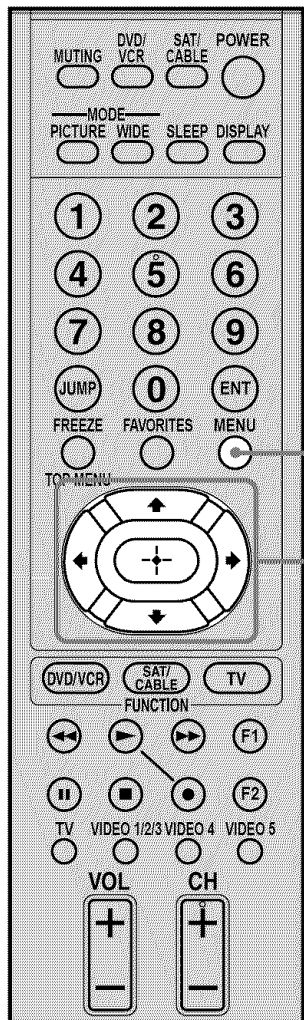

1 Press MENU.

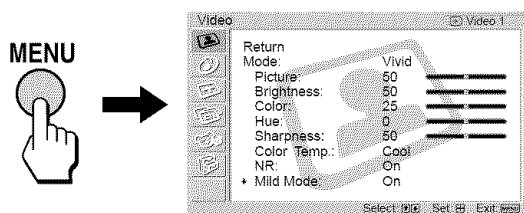

2 Press \uparrow/\downarrow to select (Audio), then press \leftarrow .

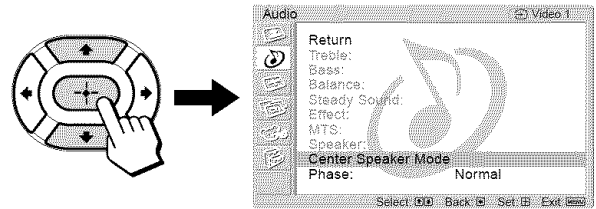

3 Press \uparrow/\downarrow to select "Phase" then press \leftarrow .

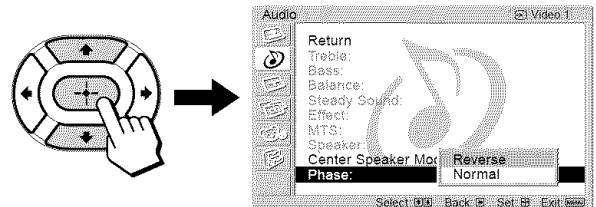

Tip

If you cannot select "Phase," change the input to the video input selected in "Center Speaker Mode."

4 Press \uparrow/\downarrow to select "Reverse," then press \leftarrow .

The sound from the TV's speakers is phase-reversed.

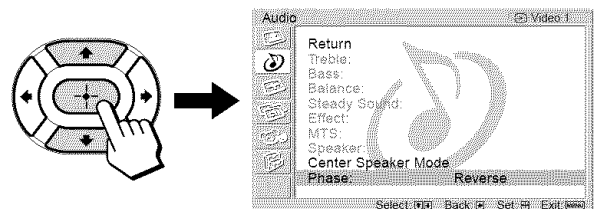

5 Press MENU to exit the menu screen.

Note

"Phase" cannot be selected when "Center Speaker Mode" is set to "Off."

Setting the Video Inputs

You can enjoy images (and sound) from optional video equipment connected to this unit by selecting the appropriate input. For details on connection, see pages 21 through 34.

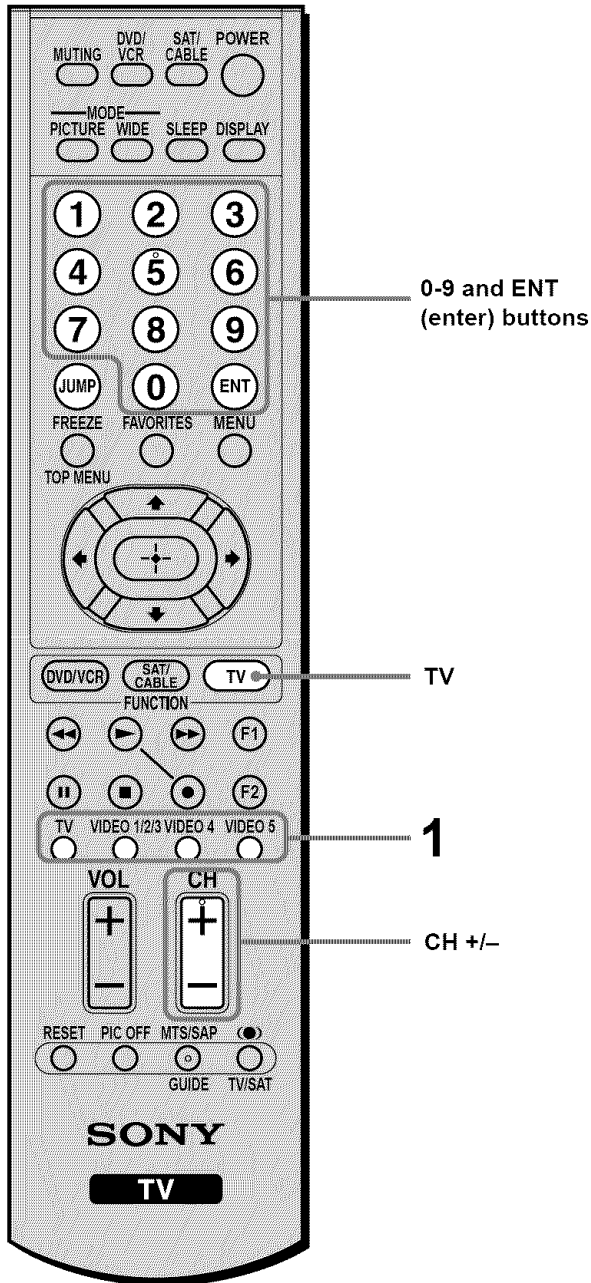

1 For video input 1, 2 and 3

Press VIDEO 1/2/3 repeatedly until the desired video input appears.

Each time you press VIDEO 1/2/3, the input changes as follows.

Select	Display indication
• VIDEO IN 1	Video 1
• VIDEO IN 2	Video 2
• VIDEO IN 3	Video 3

For video input 4 (HD/DVD IN 4)

Press VIDEO 4.

“Video 4”* indication appears.

For video input 5 (HDMI IN 5)

Press VIDEO 5.

“Video 5”* indication appears.

* The type of picture signal (480i, 480p, 720p, or 1080i) appears under “Video 4” and “Video 5.”

Tips

- When “Skip” is selected as a label using “Video Label” in the (Setup) menu, the selected input will be skipped in the cycle (see page 53).
- You can also select the inputs by using the INPUT button on the TV.

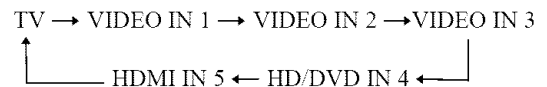

- When you have preset a label for each video input using “Video Label” in the (Setup) menu, the label will be displayed (see page 53).

2 Operate the selected optional equipment.

For details, see “Using your Remote Controls with Other Equipment” on page 16, or refer to the instructions supplied with each equipment.

To return to watching the TV

Press TV, any of 0-9 and ENT (enter) or CH +/-.

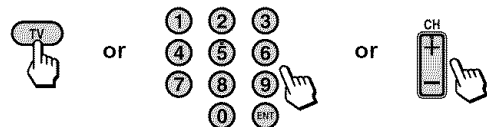

Using the Video Label and Skip Feature

You can make settings for each video input by choosing the label displayed on the screen.

Tip

If you select "Skip," your TV skips this input when you press the Input Select buttons.

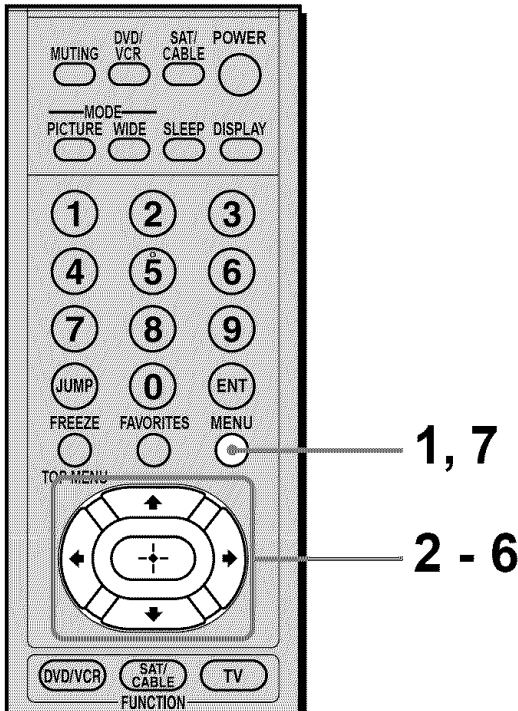

1 Press MENU.

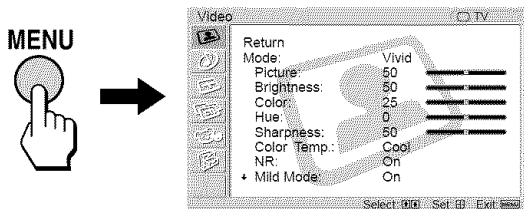

2 Press \uparrow/\downarrow to select  (Setup), then press \oplus .

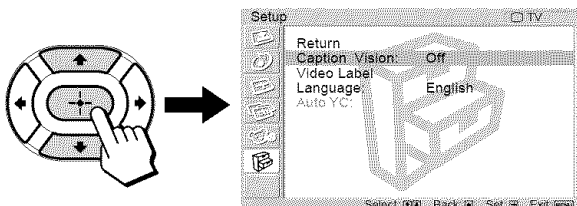

3 Press \uparrow/\downarrow to select "Video Label," then press \oplus .

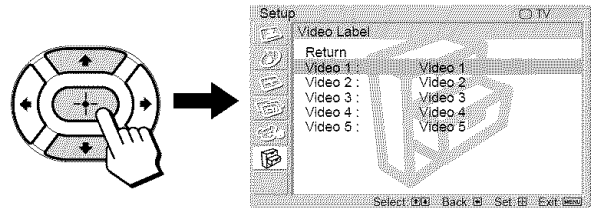

4 Press \uparrow/\downarrow to select the video input (Video 1-5) you want to assign a label, then press \oplus .

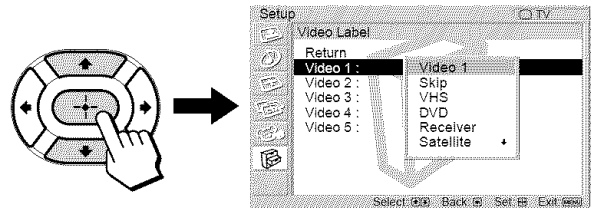

5 Press \uparrow/\downarrow to select the label, then press \oplus .

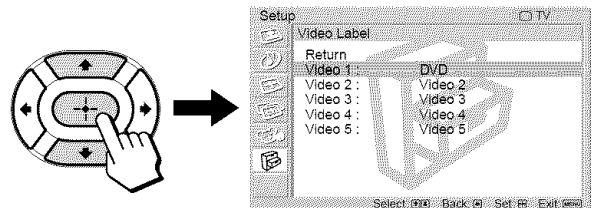

To skip the unused video input using the Input Select buttons

Press \uparrow/\downarrow to select "Skip."

6 Repeat steps 4 and 5 to assign labels to more video inputs.

You can select from the following labels for each input.

Video 1, 2, 3 Skip, VHS, DVD, Receiver, Satellite, Cable Box, 8mm, DTV, Game, LD, Beta

Video 4, 5 Skip, DVD, Satellite, Cable Box, DTV, HD

7 Press MENU to exit the menu screen.

Using Favorite Channels

You can select programs from a list of favorite channels that you preset.

Setting your favorite channels

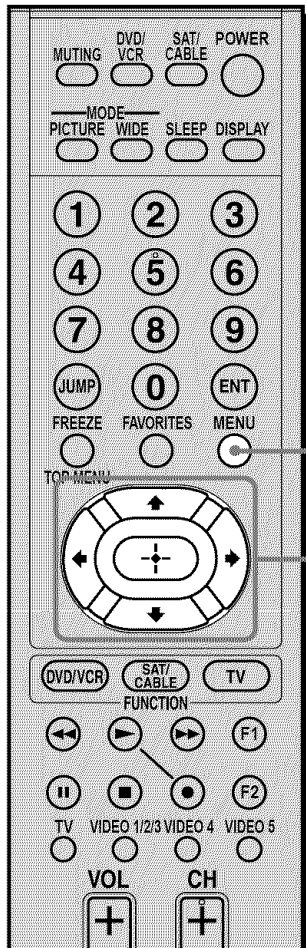

1 Press MENU.

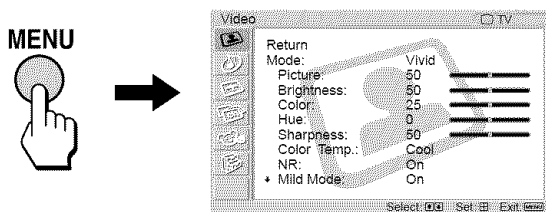

2 Press \uparrow/\downarrow to select (Channel), then press .

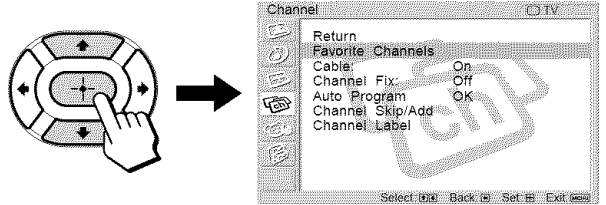

3 Press \uparrow/\downarrow to select "Favorite Channels," then press .

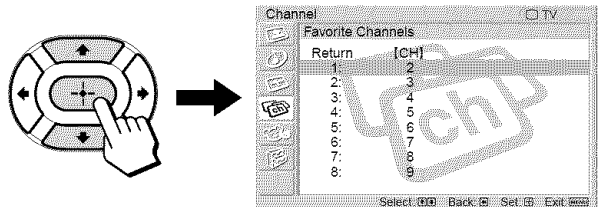

Tip

If you cannot select "Favorite Channels," change the input to TV by pressing the TV button.

4 Press \uparrow/\downarrow to select the position you want to change, then press .

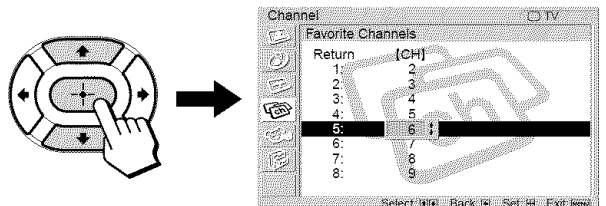

5 Press \uparrow/\downarrow to scroll through the channels until you find the desired channel, then press .

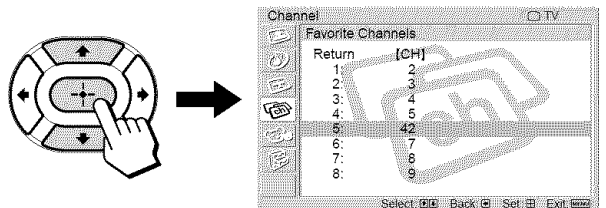

6 Repeat steps 4 and 5 to program other favorite channels.

7 Press MENU to exit the menu screen.

Watching favorite channels

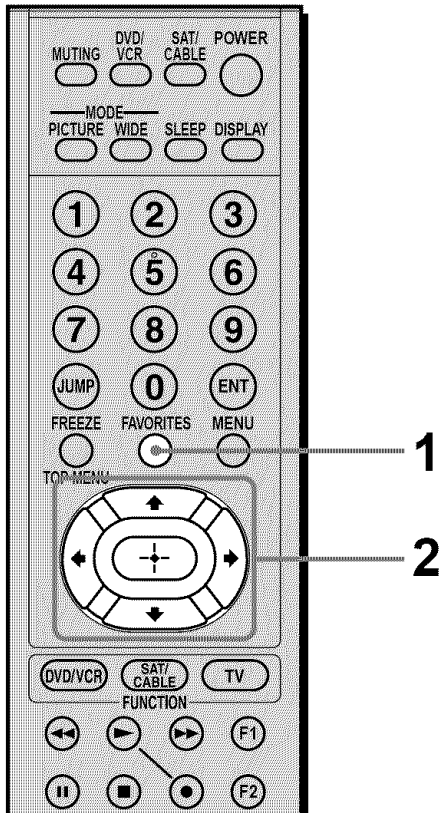

- 1 Press FAVORITES.

The Favorite Channels list appears.

FAVORITES

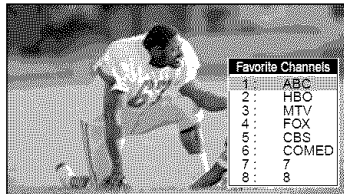
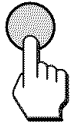

- 2 Press \uparrow/\downarrow to select the desired channel, then press \oplus .

The selected channel will be displayed.

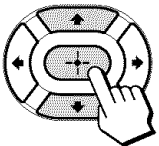

Tip

If you make an optional label using "Channel Label" in the  (Channel) menu, that label will be displayed on the screen.

Using the Channel Label Feature

If you have set an optional label for the channel display or for Favorite Channels, you can have that label displayed on the screen.

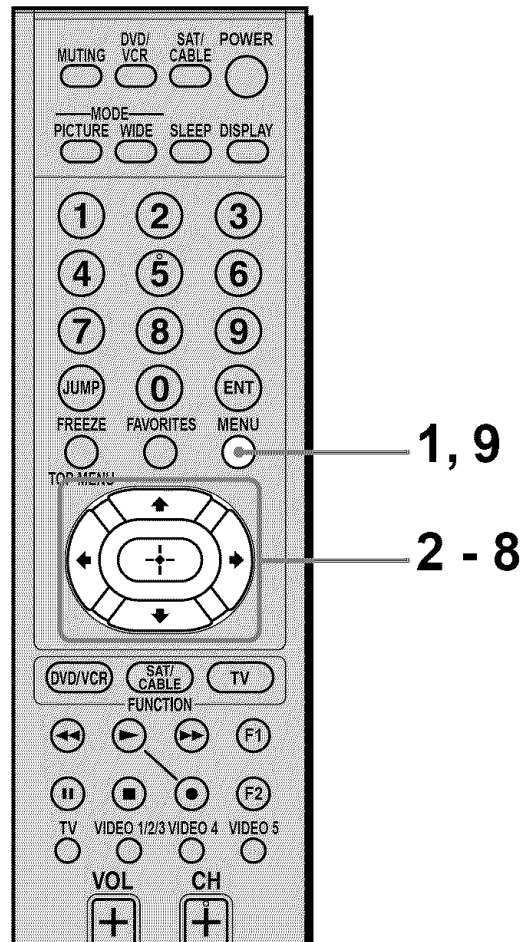

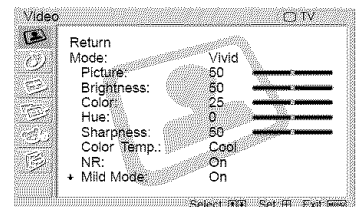

- 1 Press MENU.

MENU



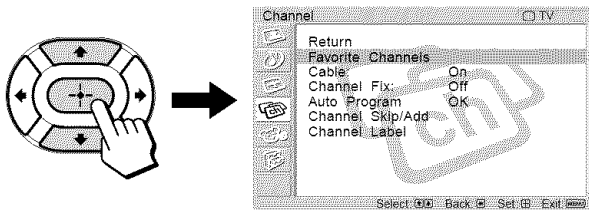

(Continued)

- 2** Press \uparrow/\downarrow to select  (Channel), then press .

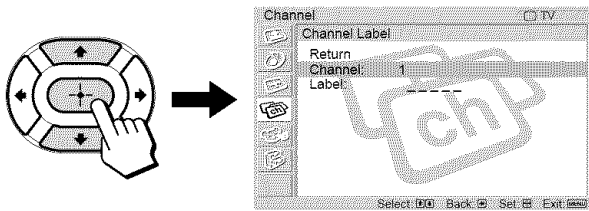

- 3** Press \uparrow/\downarrow to select "Channel Label," then press .



- 4** Press \uparrow/\downarrow to select "Channel," then press .

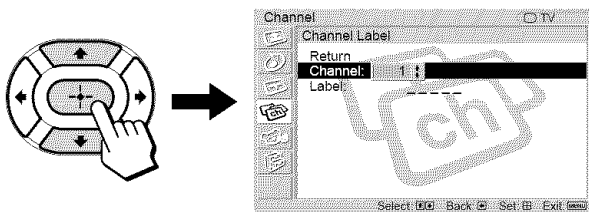

- 5** Press \uparrow/\downarrow to scroll through the channel numbers you want to assign a label, then press .

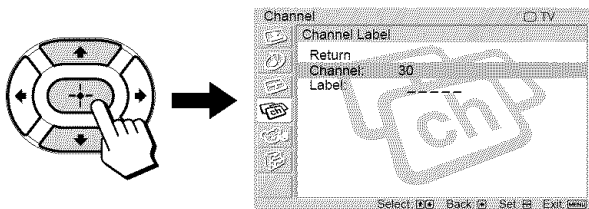

- 6** Press \uparrow/\downarrow to select "Label," then press .

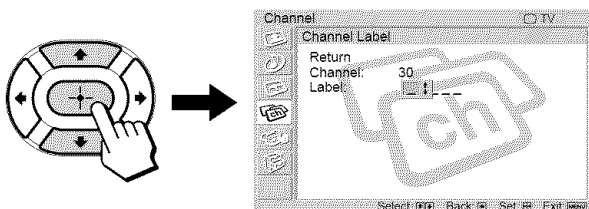

- 7** Press \uparrow/\downarrow to scroll through the label characters (A-Z, 0-9, etc.), then press .

You can add up to 5 characters to the label.

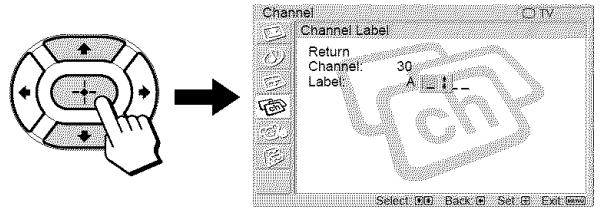

- 8** Repeat steps 4 - 7 to assign labels to more channels.

- 9** Press MENU to exit the menu screen.

Using Advanced Features

Adjusting the Picture Position Vertically

You can move the position of the picture up and down for each Wide Screen Mode (page 44) in the following cases:

- To move the position of the picture in “Wide Zoom” and “Zoom” modes
- When subtitles may not fit in the screen

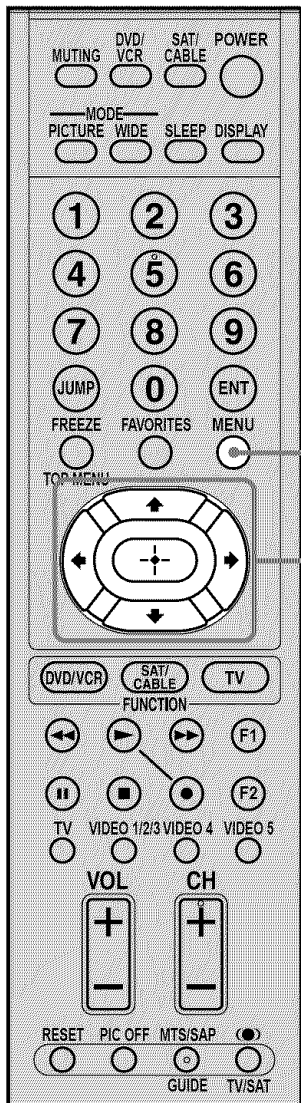



1, 5

2 - 4

- 1 Receive the picture you want to adjust, then press MENU.

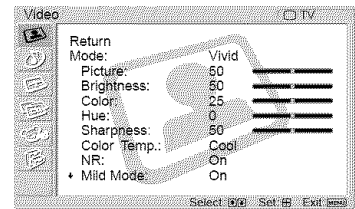
MENU



- 2 Press \uparrow/\downarrow to select  (Screen), then press .

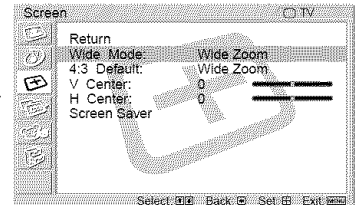
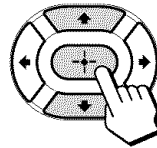

- 3 Press \uparrow/\downarrow to select “V Center,” then press .

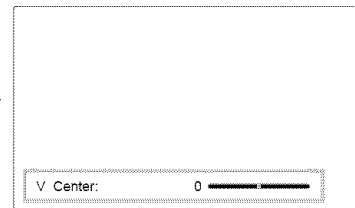
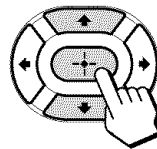

- 4 Press $\uparrow/\downarrow/\leftarrow/\rightarrow$ to adjust the position, then press .

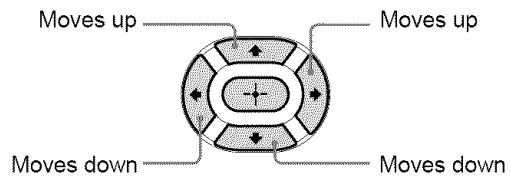

- 5 Press MENU to exit the menu screen.

Note

“V Center” cannot be adjusted when “Normal” or “Full” is selected in “Wide Mode.”

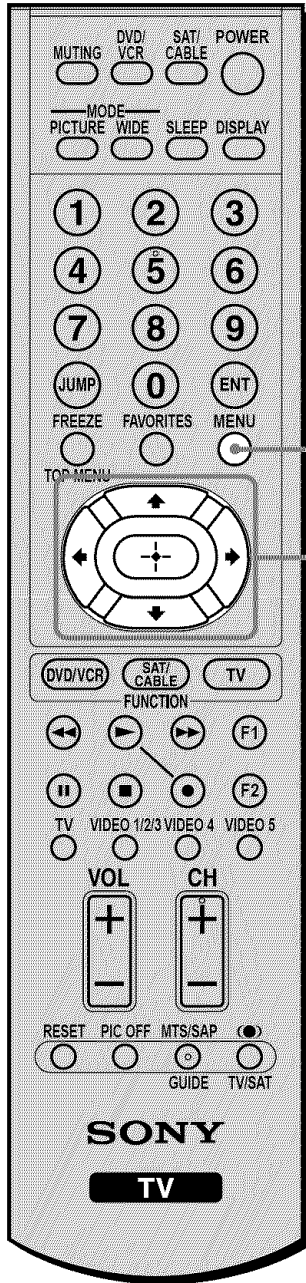

Adjusting the Picture Position Horizontally

You can move the position of the picture left and right for each Wide Screen Mode (page 44) when subtitles may not fit in the screen.

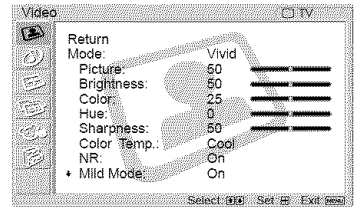

- 1 Receive the picture you want to adjust, then press MENU.



- 2 Press \uparrow/\downarrow to select  (Screen), then press .

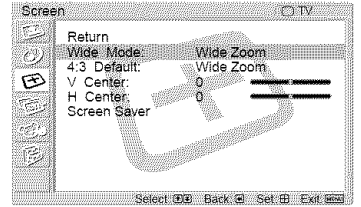
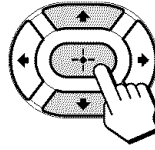

- 3 Press \uparrow/\downarrow to select "H Center," then press .

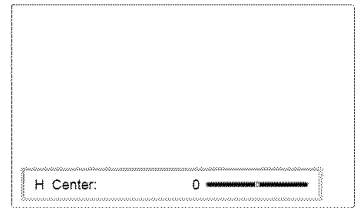
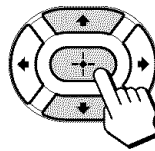

- 4 Press $\uparrow/\downarrow/\leftarrow/\rightarrow$ to adjust the position, then press .

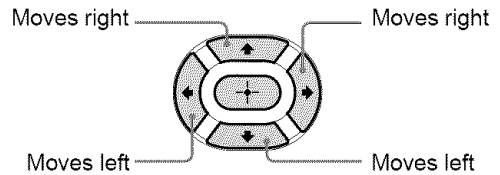

- 5 Press MENU to exit the menu screen.

Tip

"H Center" can be adjusted for every input setting.

Adjusting the Picture Quality

You can adjust the picture quality for each Picture Mode (“Vivid,” “Standard,” or “Pro”). You can adjust the picture quality for each video input selected using the Input Select buttons, and store these adjustments in memory.

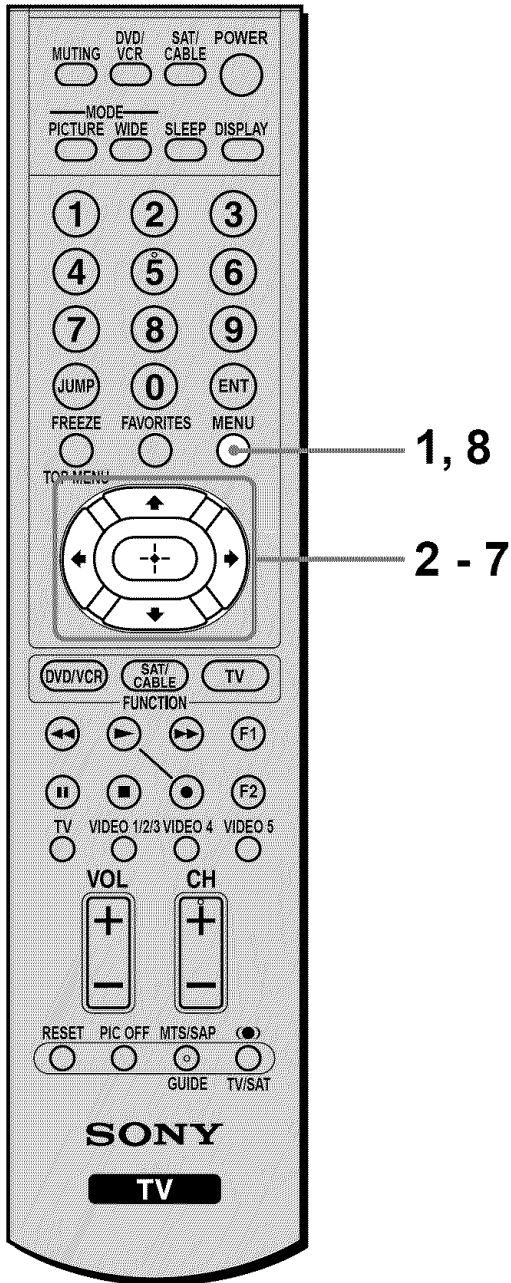

1 Press MENU.

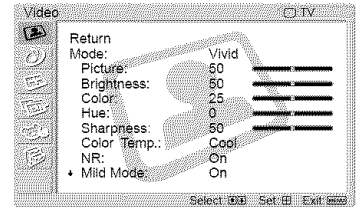

2 Press \uparrow/\downarrow to select  (Video), then press \oplus .

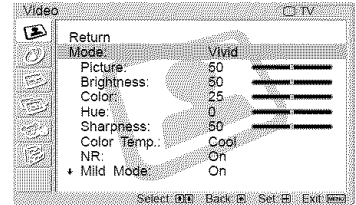
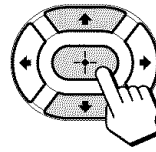

3 Press \uparrow/\downarrow to select “Mode,” then press \oplus .

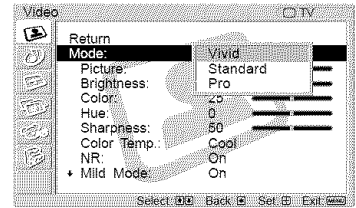
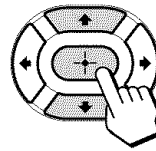

4 Press \uparrow/\downarrow to select the Picture Mode you want to adjust, then press \oplus .

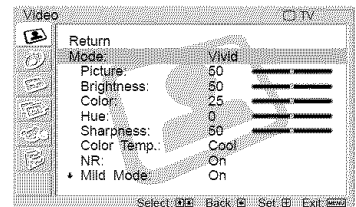
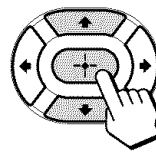

5 Press \uparrow/\downarrow to select “Picture,” then press \oplus .

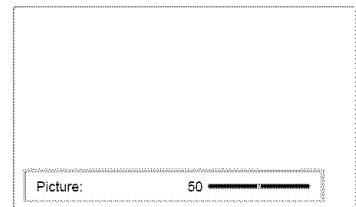
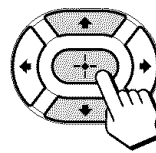

- 6 Press $\uparrow/\downarrow/\leftarrow/\rightarrow$ to make the desired adjustment, then press \oplus .

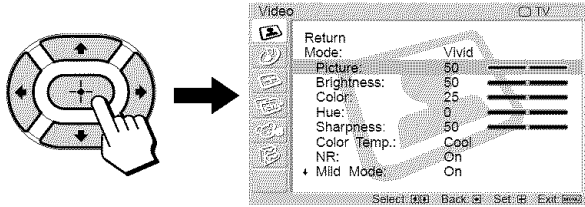

Adjustable options

Option	Press \downarrow/\leftarrow	Press \uparrow/\rightarrow
Picture	To reduce picture contrast.	To enhance picture contrast.
Brightness	To darken the picture.	To brighten the picture.
Color	To decrease color intensity.	To increase color intensity.
Hue*	To decrease the green tones.	To increase the green tones.
Sharpness	To soften the picture.	To sharpen the picture.

* The adjustment is not available for the followings:
 – 480i, 480p, 1080i and 720p signals input to HD/DVD IN 4 and HDMI IN 5

Tips

- You can adjust each option by referring to the value beside each option indicator.
- The  (Video) menu has a second scroll down screen.

Selective options

Option	Description	Setting
Color Temp. (Color Temperature)	Select to give bright colors a red tint.	Cool/ Neutral/ Warm
NR (Noise Reduction)	Select to reduce the noise level of connected equipment. It is also effective on the signal from the VHF/UHF jack.	On/Off
Mild Mode	Select for a natural, soft picture.	On/Off
Dynamic Picture	Select to enhance the picture contrast.	On/Off
CineMotion	Select to provide an optimized display by automatically detecting film content. Moving pictures will become clearer and more natural. When the superimposed text on the film content appears corrupted, set “CineMotion” to “Off.”	On/Off

Tip

“CineMotion” is only available for 480i input signal from VIDEO IN 1, 2, 3, HD/DVD IN 4 and HDMI IN 5.

- 7 Repeat steps 5 and 6 to adjust other options.

- 8 Press MENU to exit the menu screen.

To reset to the factory settings

Press RESET while the menu is on the screen and the cursor is located on the right side of any menu item.

RESET



Adjusting the Sound Quality

You can adjust the sound quality for each video input selected using the Input Select buttons, and store these adjustments in memory. For details on the Effect mode, see page 43.

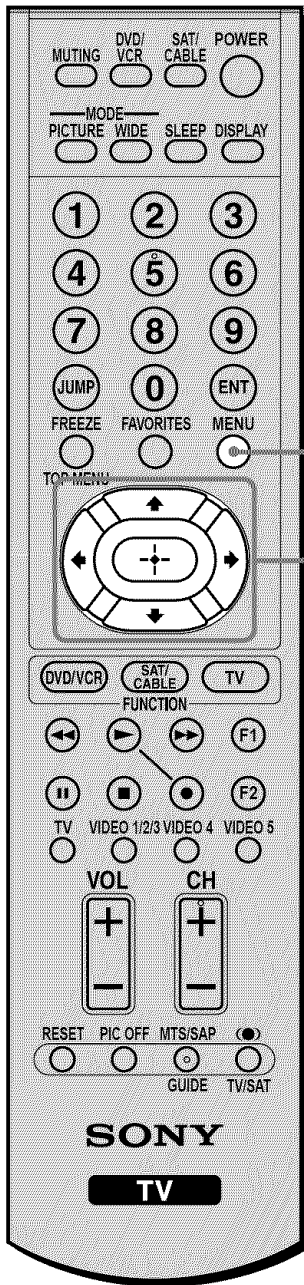

1 Press MENU.

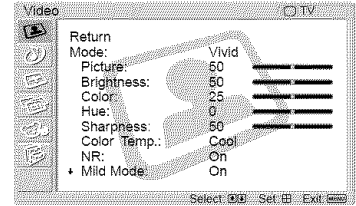

2 Press \uparrow/\downarrow to select  (Audio), then press \oplus .

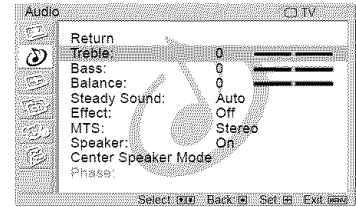
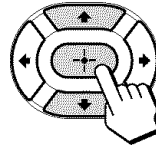

3 Press \uparrow/\downarrow to select the option you want to adjust, then press \oplus .

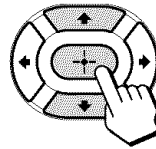

4 Press $\uparrow/\downarrow/\leftarrow/\rightarrow$ to make the desired adjustment, then press \oplus .

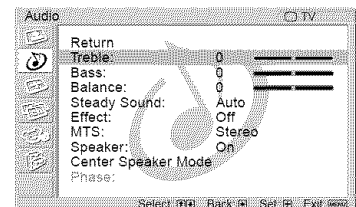
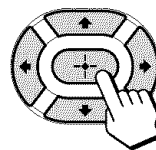



Adjustable options

Option	Press ↓/←	Press ↑/→
Treble*	To decrease higher-pitched sounds.	To increase higher-pitched sounds.
Bass*	To decrease lower-pitched sounds.	To increase lower-pitched sounds.
Balance*	To emphasize the left speaker.	To emphasize the right speaker.

Selective options

Option	Description	Setting
Steady Sound*	Select to stabilize the volume.	Auto/Off
Effect**	See page 43.	

* To adjust any of these options, set “Speaker” in the  (Audio) menu to “On,” or “Audio Out” to “Variable” first.

** To adjust the option, set “Speaker” in the  (Audio) menu to “On” first.

Tip

You can adjust each option by referring to the value beside each option indicator.

5 Repeat steps 3 and 4 to adjust other options.

6 Press MENU to exit the menu screen.

To reset to the factory settings

Press RESET while the menu is on the screen and the cursor is located on the right side of any menu item.

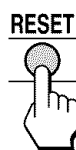

Note

Resetting the unit to the factory settings resets only “Treble,” “Bass” and “Balance.”

Selecting Stereo or Bilingual Programs

You can enjoy stereo, bilingual and mono programs.

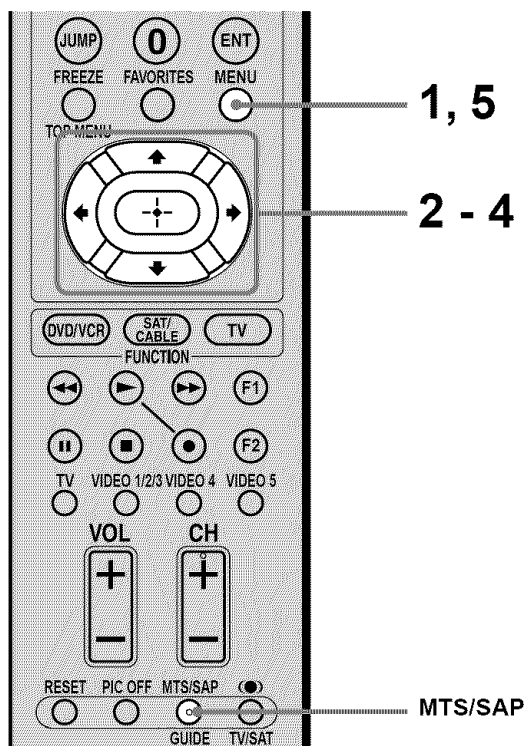

Press MTS/SAP repeatedly until the desired sound indication appears.

Each time you press the button, the sound indication changes as follows:

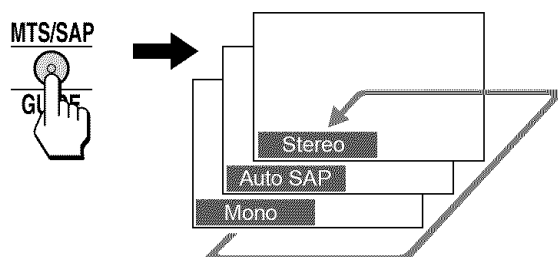

Sound indication*	Description
Stereo	Select for stereo reception when viewing a program broadcast in stereo.
Auto SAP	Select to automatically switch the TV to second audio programs when a signal is received. (If no SAP signal is present, the TV remains in Stereo mode.)
Mono	Select for mono reception. (Use to reduce noise during weak stereo broadcasts.)

* This is available only for TV broadcasting.

Selecting stereo or bilingual programs using the menu

1 Press MENU.

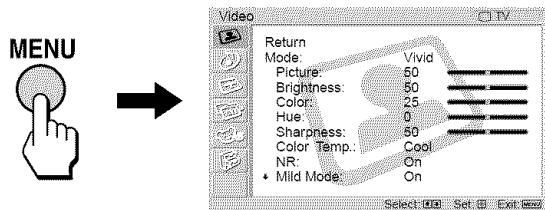

2 Press \uparrow/\downarrow to select \odot (Audio), then press \oplus .

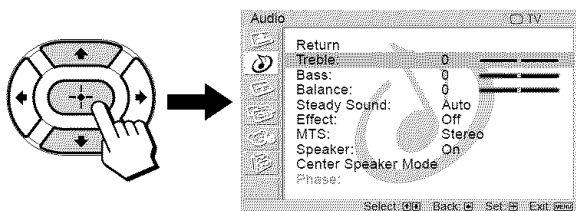

3 Press \uparrow/\downarrow to select "MTS," then press \oplus .

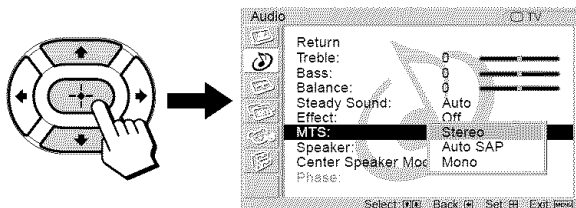

4 Press \uparrow/\downarrow to select the desired reception, then press \oplus .

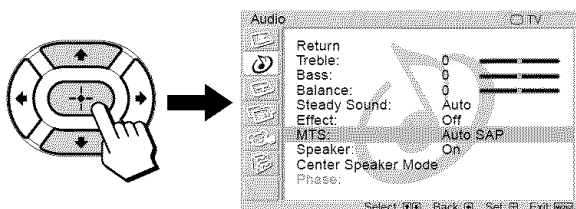

5 Press MENU to exit the menu screen.

Selecting How to Control the Volume of the TV's Speakers

You can select how to control the volume of the TV's speakers when an external amplifier is connected to the TV's audio outputs.

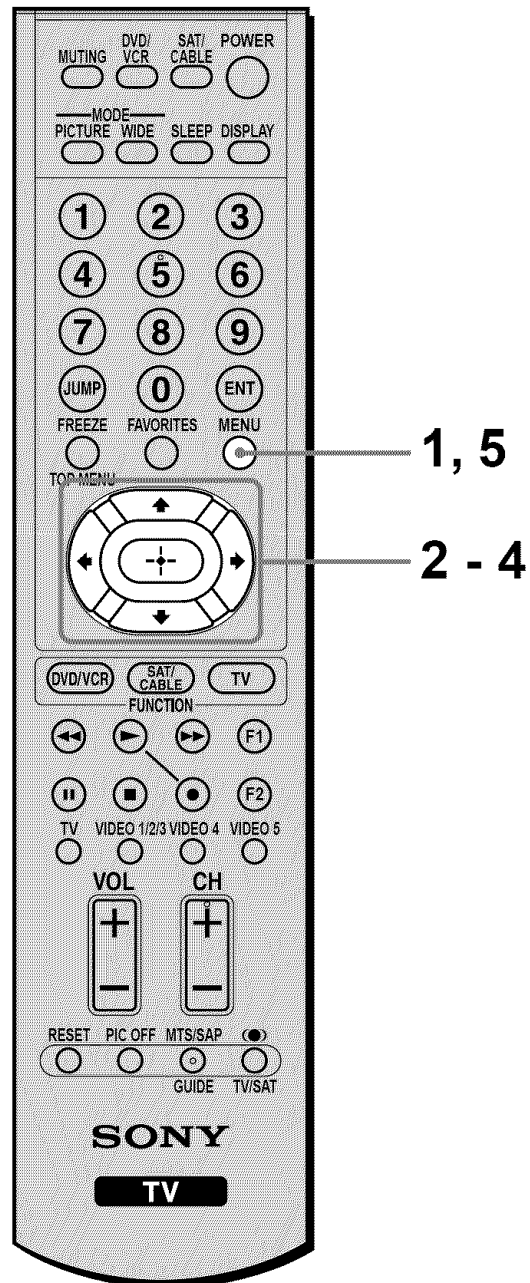

1 Press MENU.

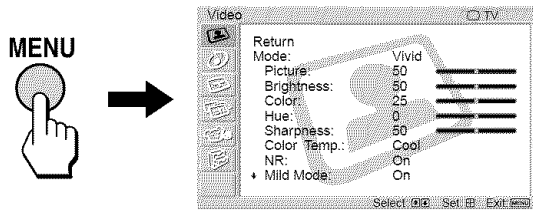

2 Press \uparrow/\downarrow to select (Audio), then press \oplus .

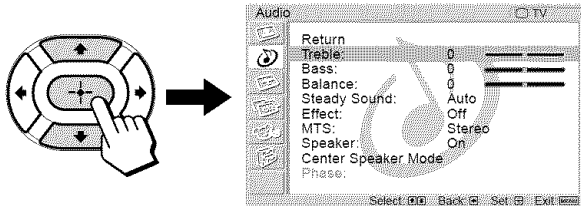

3 Press \uparrow/\downarrow to select "Audio Out," then press \oplus .

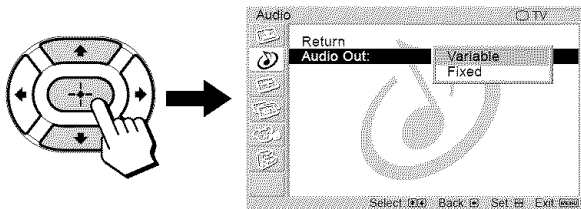

Option	Description
Audio Out (Easy control of volume adjustments)	<p>Variable The TV's speakers are turned off, but the audio output from your audio system can still be controlled by the TV's remote control.</p>
	<p>Fixed The TV's speakers are turned off and the audio output of the TV is fixed. Use your audio receiver's remote control to adjust the volume (and other audio settings) through your audio system.</p>

4 Press \uparrow/\downarrow to select the desired option, then press \oplus .

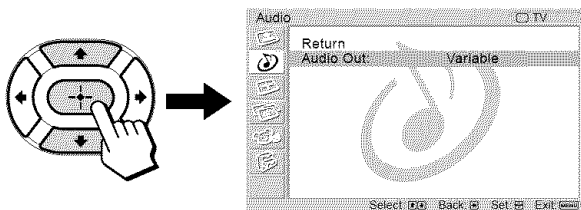

5 Press MENU to exit the menu screen.

Note

"Audio Out" can be selected only when the "Speaker" is set to "Off."

Selecting the TV Speakers or an External Amplifier to Listen to the TV

You can select if you want to listen to the TV from the TV speakers or from an external amplifier connected to the TV's audio outputs.

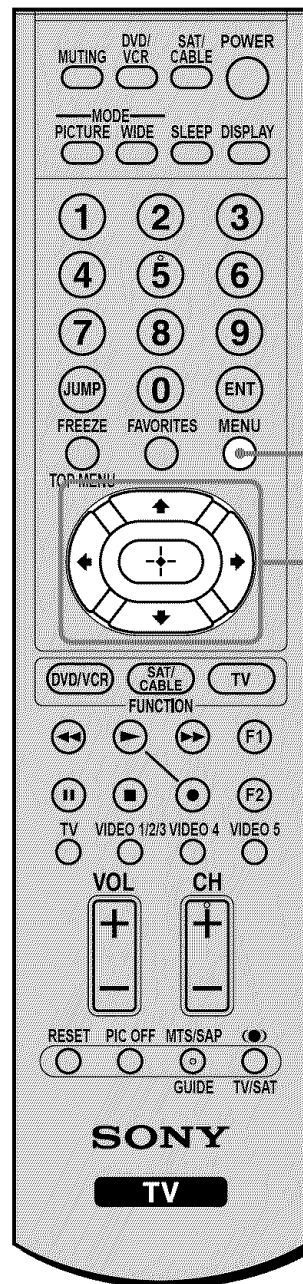

1 Press MENU.

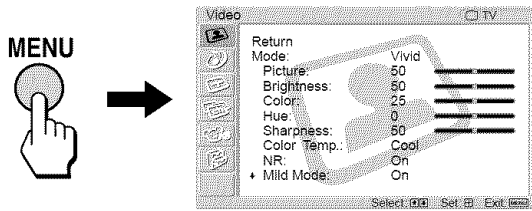

2 Press \uparrow/\downarrow to select A (Audio), then press + .

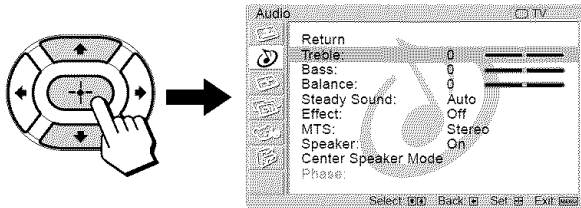

3 Press \uparrow/\downarrow to select "Speaker," then press + .

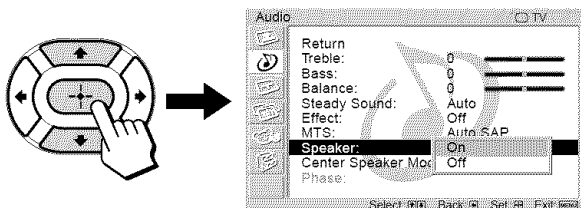

Option	Description	
Speaker	On	Select to turn on the TV speakers.
	Off	Select to turn off the TV speakers and listen to the TV's sound only through your external audio system speakers.

4 Press \uparrow/\downarrow to select the desired option, then press + .

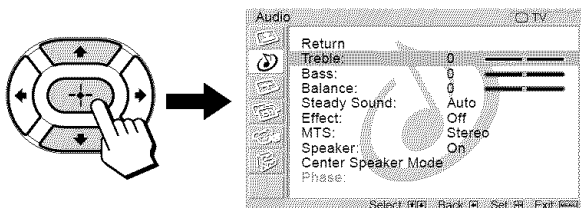

5 Press MENU to exit the menu screen.

Using the Parental Control Feature

The TV programs and movies shown on TV are given a rating signal based on the following rating systems.

In U.S.A.: U.S. Television Parental Guidelines to rate television programs (U.S. TV ratings), and Motion Picture Association of America (MPAA) Guidelines to rate movies including those shown on TV (movie ratings).

In Canada: Canadian English Language ratings to rate television programs in English, and Canadian French Language ratings to rate those in French.

To block programs you feel unsuitable for your children, you need to set the TV for the desired rating systems. Sony's predetermined ratings are also available. See page 70 for a description of the ratings.

The TV's Parental Control feature functions by receiving the rating signal from your local broadcasting station or cable service provider.

Activating the Parental Control feature

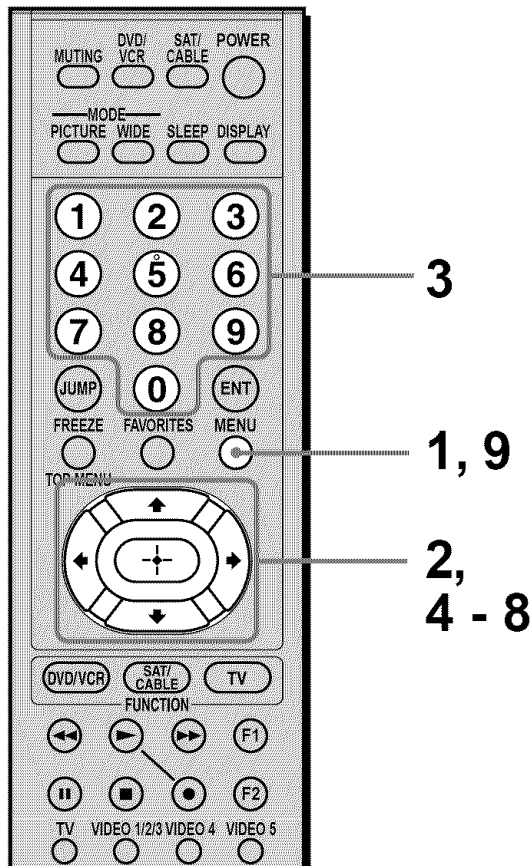

1 Press MENU.

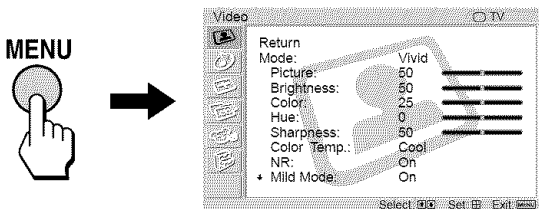

2 Press \uparrow/\downarrow to select  (Parent), then press \oplus .

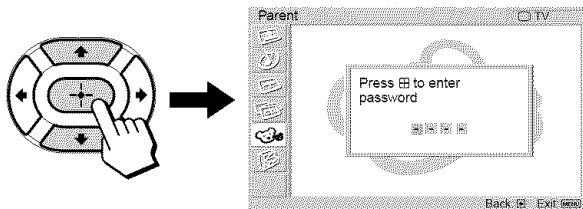

3 Enter a four-digit password using the 0-9 buttons, then, press \oplus .

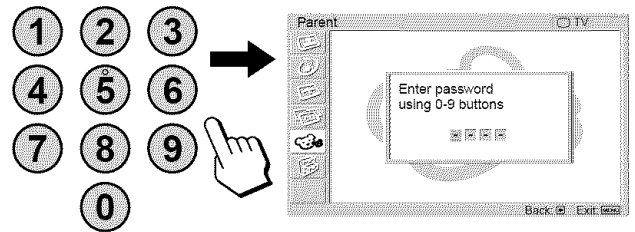

4 The Parent menu options appear.

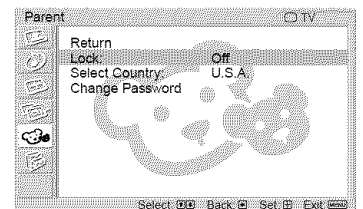

If you access the Parent menu for the first time, you are requested to enter the password again for confirmation.

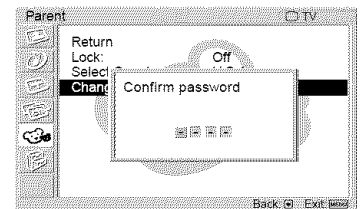

Note

Do not enter "4357" corresponding to "HELP" on a phone number pad (see page 67).

Tips

- You need to enter the password here for any further access into the Parent menu. If you lose your password, see "Tip" on page 67.
- If you want to change the password, see page 67.

5 Press \uparrow/\downarrow to select "Select Country," then press \oplus .

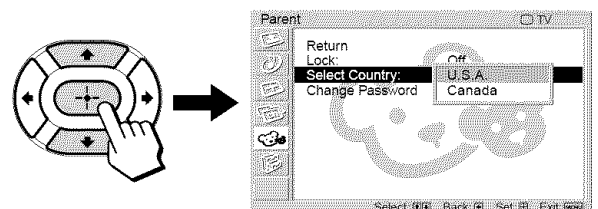

- 6** Press \uparrow/\downarrow to select your country/region (U.S.A. or Canada), then press \oplus .

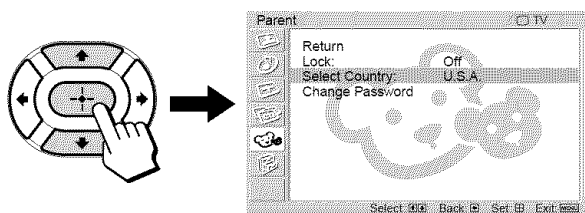

- 7** Press \uparrow/\downarrow to select “Lock,” then press \oplus .

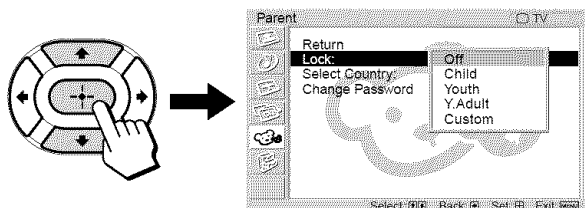

- 8** Press \uparrow/\downarrow to select a desired rating, then press \oplus .

If you select “Child,” “Youth,” or “Y.Adult” (Young Adult), the Parental Control is activated automatically.

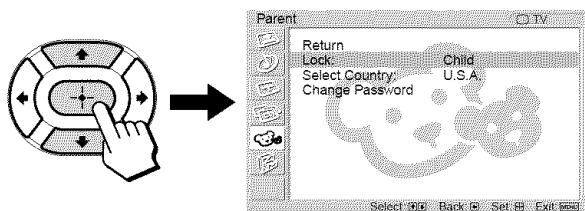

Tip

If you are not familiar with the Parental Guideline rating system, you should select “Child,” “Youth,” or “Y.Adult (Young Adult)” to help simplify the rating selection. To set more restrictive ratings, select “Custom” (see “Selecting a Custom Rating” on page 68).

- 9** Press MENU to exit the menu screen.

To view blocked programs

You can view blocked programs by entering the password.

- 1 Press ENT (enter) when tuned to a blocked program.
- 2 Enter your four-digit password using the 0-9 buttons.

The Parental Control feature will be canceled temporarily until you turn the TV off.

To deactivate the Parental Control feature

Set “Lock” to “Off” in the  (Parent) menu.

To change the password

- 1 Press MENU.
- 2 Press \uparrow/\downarrow to select  (Parent), then press \oplus .
- 3 Enter your four-digit password using the 0-9 buttons.

The Parent menu options appear.

- 4 Press \uparrow/\downarrow to select “Change Password,” then press \oplus .
- 5 Enter a new four-digit password using the 0-9 buttons.
- 6 Enter the password set in step 5 again to confirm.
- 7 Press MENU to exit the menu screen.

Tip

If you have forgotten your password, enter the master password “4357” (corresponding to “HELP” on a phone number pad) in step 3. You can then store a new password.

Notes

- “4357” cannot be set as your password. If you entered “4357,” the message of “Password incorrect press \oplus to try again” appears.
- When you select a Parental Control program and the  indication is displayed on the screen, you cannot view that program even if you enter “4357” (see “To view blocked programs” on page 67).

Selecting a Custom Rating

If you want to select the ratings to be blocked from “Custom” once you have activated the Parental Control feature (page 66), follow the procedure below.

For a detailed description of each rating, see “What the Ratings Mean” on page 70.

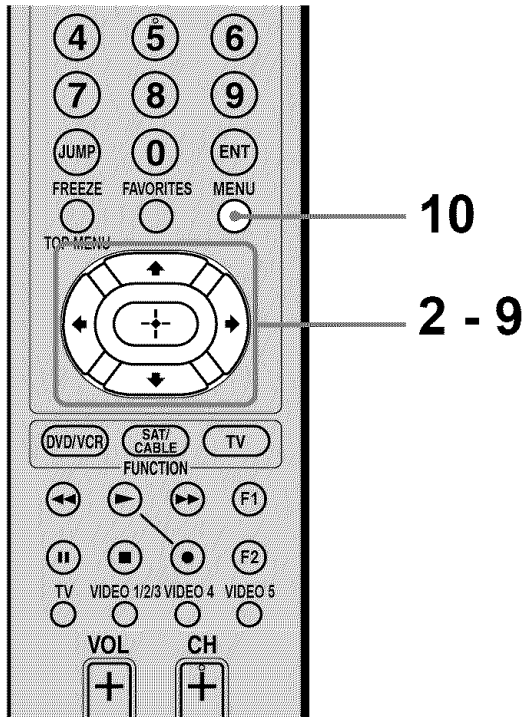

1 Perform steps 1 to 7 in “Activating the Parental Control feature” on page 66 to display the Lock options.

2 Press \uparrow/\downarrow to select “Custom,” then press \ominus .

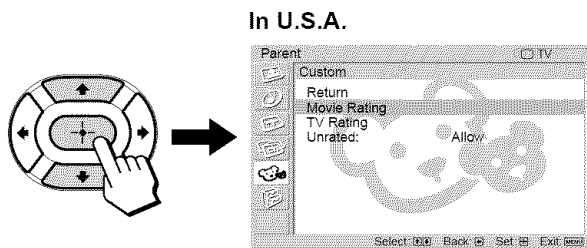

In Canada

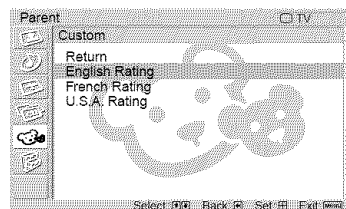

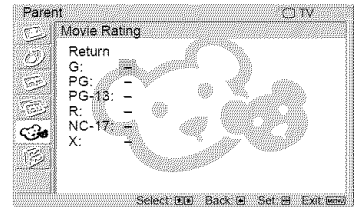
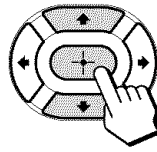

To select a rating in Canada, go to step 6.

3 Press \uparrow/\downarrow to select “Movie Rating,” then press \ominus .



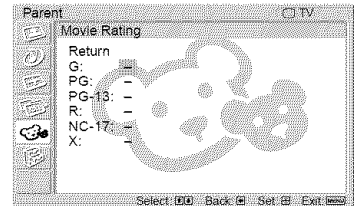
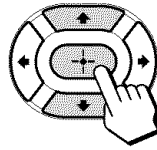

4 Press \uparrow/\downarrow to select the rating to be blocked, then press \ominus .

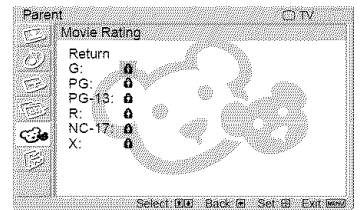

The  indication automatically appears beside the selected rating and all ratings below it, indicating that the programs that match the ratings will be blocked.



To unlock a rating, select , then press \ominus . The  indication changes into “-” and all ratings above it are unlocked.

5 Press \leftarrow to return to the “Custom” menu.

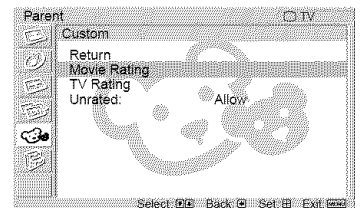
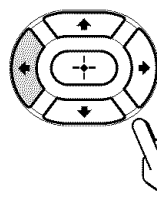

- 6** To select a TV rating in U.S.A.:
Press \uparrow/\downarrow to select “TV Rating,” then press \oplus .

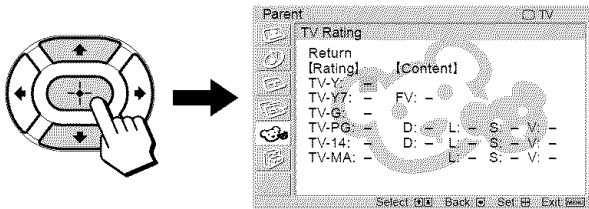

To select a TV rating in Canada:

- Press \uparrow/\downarrow to select “English Rating,” “French Rating,” or “U.S.A. Rating,” then press \oplus .

English Rating

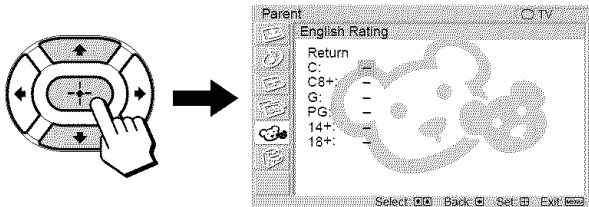

French Rating

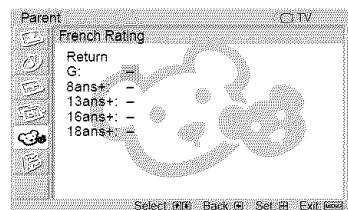

U.S.A. Rating

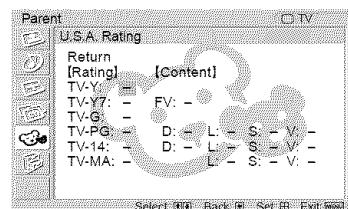

- 7** Press \uparrow/\downarrow to select the TV rating to be blocked, then press \oplus .

The \mathfrak{L} indication automatically appears beside the selected rating and all ratings below it, indicating that the programs that match the ratings will be blocked.

Example: TV rating in U.S.A.

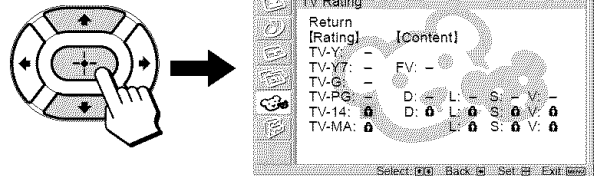

- To unlock a rating, select \mathfrak{L} , then press \oplus . The \mathfrak{L} indication changes into “-” and all ratings above it are unlocked.

Some U.S. TV ratings have additional content ratings called “extenders.”

The extenders are defined as follows:

D (sexually suggestive Dialog), FV (Fantasy Violence), L (coarse Language), S (Sexual situations) and V (Violence).

By setting the extenders, you can define additional viewing limits.

For more details on extenders, see page 72.

All of the extenders included in the selected ratings will be blocked. If you want to allow any of them to be viewed, go to step 8. Otherwise, go to step 10.

- 8** Press \leftarrow/\rightarrow to select the extender to be viewed, then press \oplus .

“-” appears beside the selected extender, indicating that the programs that match the extender can be viewed.

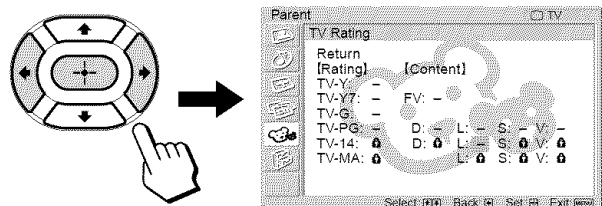

To relock the canceled extender, select \mathfrak{L} . The \mathfrak{L} indication appears to show that the programs that match the extender will be blocked again.

(Continued)

9 Repeat step 8 for other extenders.

All programs that match the ratings you select and higher, except for the extenders that were canceled, will be blocked.

10 Press MENU to exit the menu screen.

To block programs or movies broadcast without a rating

Unrated option allows you to block programs or movies that are broadcast without a rating.

The unrated option is available only when you have selected U.S.A. as your country/region.

1 Perform steps 1 and 2 of “Selecting a Custom Rating” on page 68.

2 Press \uparrow/\downarrow to select “Unrated,” then press \oplus .

3 Press \uparrow/\downarrow to select “Block,” then press \oplus .

Option	Description
Allow	Allows programs and movies that are broadcast without a rating.
Block	Blocks all programs and movies that are broadcast without a rating.

4 Press MENU to exit the menu screen.

Note

If you choose to block unrated TV programs, be aware that the following types of programs may be blocked: programs broadcast from another country/region, emergency broadcasts, political programs, sports, news, public service announcements, religious programs, and weather.

What the Ratings Mean

Ratings in the U.S.A.

Sony's predetermined ratings

These are original ratings that Sony has predetermined according to the viewer's age. Each rating allows for viewing of certain programs, as follows:

Option	Description
Child	Suitable for children under the age of 7. Viewable U.S. movie ratings: G, NR, and N/A Viewable U.S. TV ratings: TV-Y, TV-G, and TV-NR
Youth	Suitable for children aged 7 and older. Viewable U.S. movie ratings: G, PG, NR, and N/A Viewable U.S. TV ratings: TV-Y, TV-Y7, TV-G, TV-PG, and TV-NR
Y.Adult (Young Adult)	Suitable for children aged 13 and older. Viewable U.S. movie ratings: G, PG, PG-13, NR, and N/A Viewable U.S. TV ratings: TV-Y, TV-Y7, TV-G, TV-PG, TV-14, and TV-NR

For descriptions of Child, Youth, and Y.Adult (Young Adult) ratings, see the following custom rating options.

U.S. movie ratings

U.S. movie ratings are for movies (including those shown on TV) rated according to the Motion Picture Association of America (MPAA) Guidelines.

Option	Description
G (General Audiences — All Ages Admitted)	In G-rated films, no strong words are used, the violence is at a minimum, nudity and sex scenes are not present, nor is there any drug use.
PG (Parental Guidance Suggested — Some Material May Not Be Suitable For Children)	This is a film which may need to be monitored first by parents.
PG-13 (Parents Strongly Cautioned — Some Material May Be Inappropriate For Children Under 13)	Parents are alerted to be very careful about the attendance of their under-teenage children when viewing.
R (Restricted — Under 17 Requires Accompanying Parent Or Adult Guardian)	This film includes hard language, tough violence, nudity, drug abuse or other elements of concern.
NC-17 or X (No One 17 And Under Admitted)	This is a film that most parents would consider not suitable for children aged 17 and under. There may be violence, sex, abhorrent behavior, drug abuse or other elements of concern.

U.S. TV ratings

U.S. TV ratings are for TV programs rated according to the U.S. Television Parental Guidelines.

Option	Description
TV-Y (All Children)	This program is designed for young children aged 2 - 6 and is appropriate for all children.
TV-Y7 (Directed to Older Children)	This program is designed for children aged 7 and older. Themes and elements in this program may include mild fantasy violence or slapstick violence, or may frighten children under the age of 7.
TV-G (General Audience)	Most parents would find this program suitable for all ages. It contains little or no violence, no strong language and little or no sexual dialog or situations.
TV-PG (Parental Guidance Suggested)	This program contains some material that parents may find unsuitable for younger children.
TV-14 (Parents Strongly Cautioned)	This program contains some material that many parents would find unsuitable for children under the age of 14.
TV-MA (Mature Audience Only)	This program is specifically designed to be viewed by adults and therefore may be unsuitable for children under the age of 17.

(Continued)

About the extenders of U.S. TV ratings

TV-Y7, TV-PG, TV-14 and TV-MA ratings have additional content ratings called “extenders” to define additional viewing limits. The extenders are defined as follows:

Option	Description
FV (Fantasy Violence)	Programs containing cartoon violence occurring in TV-Y7 programs only.
D (sexually suggestive Dialog)	Programs containing suggestive dialog, or sexual innuendo.
L (coarse Language)	Programs containing coarse language.
S (Sexual situations)	Programs containing sexual content.
V (Violence)	Programs containing violence. There may be some profanity, violence or brief nudity in these programs.

Ratings in Canada

Sony's predetermined ratings

These are original ratings that Sony has predetermined according to the viewer's age. Each rating allows you to view the certain programs, as follows:

Option	Description
Child	Suitable for children under the age of 8. Viewable Canadian English Language ratings: C and G Viewable Canadian French Language ratings: G Viewable U.S. TV ratings: TV-Y, TV-G, and TV-NR
Youth	Suitable for children aged 8 and older. Viewable Canadian English Language ratings: C, G, C8+, and PG Viewable Canadian French Language ratings: G and 8 ans+ Viewable U.S. TV ratings: TV-Y, TV-Y7, TV-G, TV-PG, and TV-NR
Y.Adult (Young Adult)	Suitable for children aged 14 and older. Viewable Canadian English Language ratings: C, G, C8+, PG, and 14+ Viewable Canadian French Language ratings: G, 8 ans+, and 13 ans+ Viewable U.S. TV ratings: TV-Y, TV-Y7, TV-G, TV-PG, TV-14, and TV-NR

For descriptions of Child, Youth, and Y.Adult (Young Adult) ratings, see the following custom rating options.

Canadian English Language ratings

The Canadian English Language ratings are for TV programs in English broadcast in Canada.

Option	Description
C (Programming intended for children under the age of 8)	There will be no realistic scenes of violence or no offensive language, nudity or sexual content. Careful attention is paid to themes, which could threaten children's sense of security and well-being.
C8+ (Programming generally considered acceptable for children aged 8 and older to watch on their own)	Violence will not be portrayed as the preferred, acceptable, or only way to resolve conflict; or children will not be encouraged to imitate dangerous acts which they may see on television. There will be no profanity, nudity or sexual content.
G (General Audience)	Will contain very little violence, either physical or verbal or emotional. There may be some inoffensive slang, no profanity and no nudity.
PG (Parental Guidance)	Programming intended for a general audience but which may not be suitable for younger children. Parents may consider some content inappropriate for unsupervised viewing by children aged 8 - 13.
14+ (Programming contains themes or content which may not be suitable for viewers under the age of 14)	Parents are strongly cautioned to exercise discretion in permitting viewing by pre-teens and early teens.
18+ (Adult)	May contain violence integral to the development of the plot, character or theme, intended for adult audiences. May contain graphic language and explicit portrayals of nudity and/or sex.

Canadian French Language ratings

The Canadian French Language ratings are for TV programs in French broadcast in Canada.

Option	Description
G (General)	Programming intended for audience of all ages. Contains no violence, or the violence it contains is minimal or is depicted appropriately with humor or caricature or in an unrealistic manner.
8 ans+ (8+ General — Not recommended for young children)	Programming intended for a broad audience but contains light or occasional violence that could disturb young children. Viewing with an adult is recommended for young children (under the age of 8).
13 ans+ (Programming may not be suitable for children under the age of 13)	Viewing with an adult is strongly recommended for children under the age of 13.
16 ans+ (Programming is not suitable for children under the age of 16)	Contains frequent scenes of violence or intense violence.
18 ans+ (Programming restricted to adults)	Contains constant violence or scenes of extreme violence.

Using the Screen Saver Function

You can reduce image retention to move the picture position and display a white screen.

Note

The Screen Saver function does not prevent image retention completely if the same picture is displayed for an extended period of time.

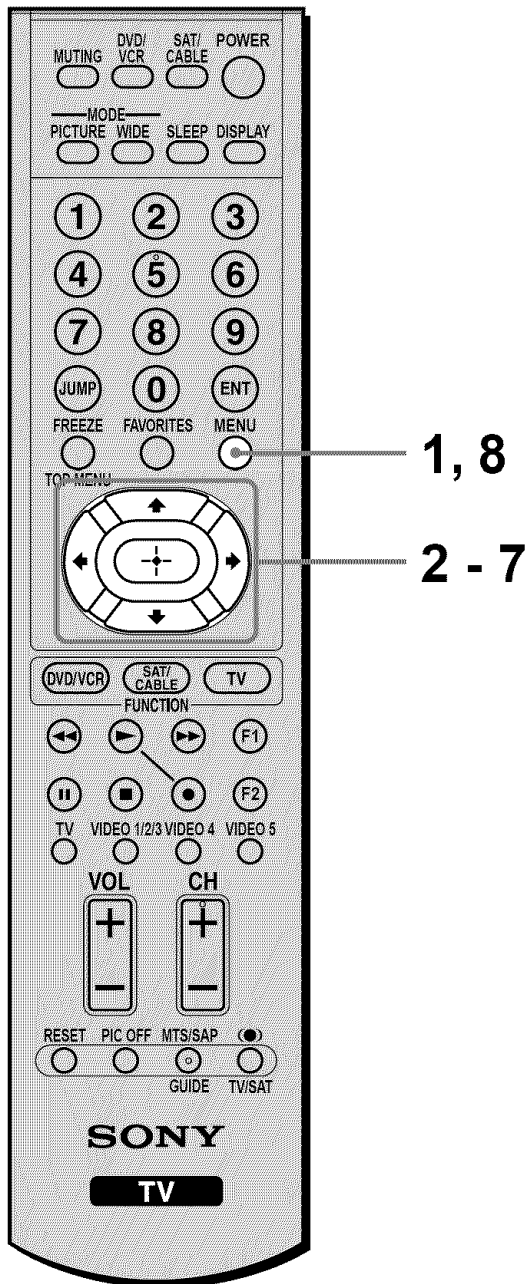

1 Press MENU.

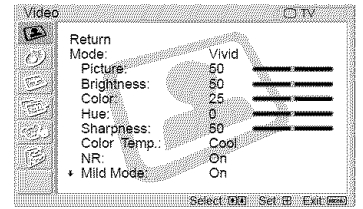

2 Press \uparrow/\downarrow to select , then press .

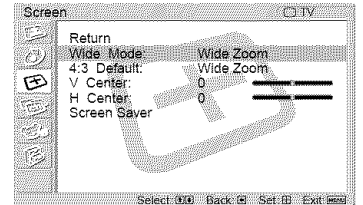
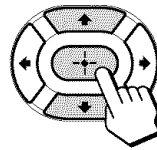

3 Press \uparrow/\downarrow to select "Screen Saver," then press .

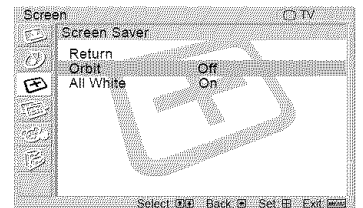
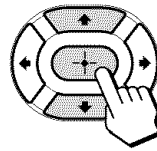

4 Press \downarrow/\uparrow to select "Orbit," then press .

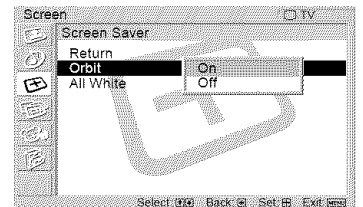
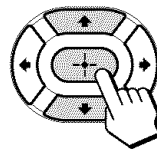

5 Press \downarrow/\uparrow to select "On," then press .

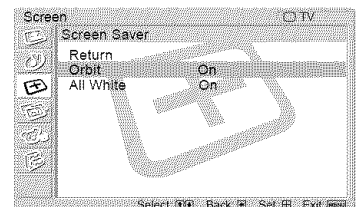
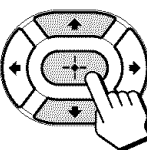

The picture moves every 30 seconds.

6 Press \downarrow/\uparrow to select "All White," then press \oplus .

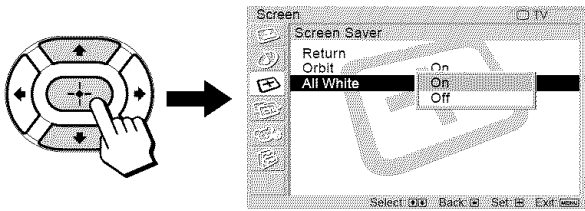

7 Press \downarrow/\uparrow to select "On," then press \oplus .

The screen appears white for 30 minutes.

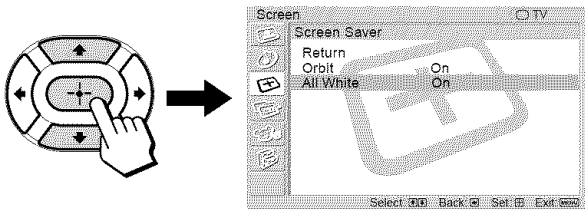

8 Press MENU to exit the menu screen.

Tips

- All White function finishes automatically after 30 minutes. If image retention is still present, repeat the function again.
- To cancel "All White" and return to normal viewing, press any button on the remote control.

Turning Off the TV Automatically

You can set the TV to turn off automatically after a predetermined period of time (15, 30, 45, 60, or 90 minutes).

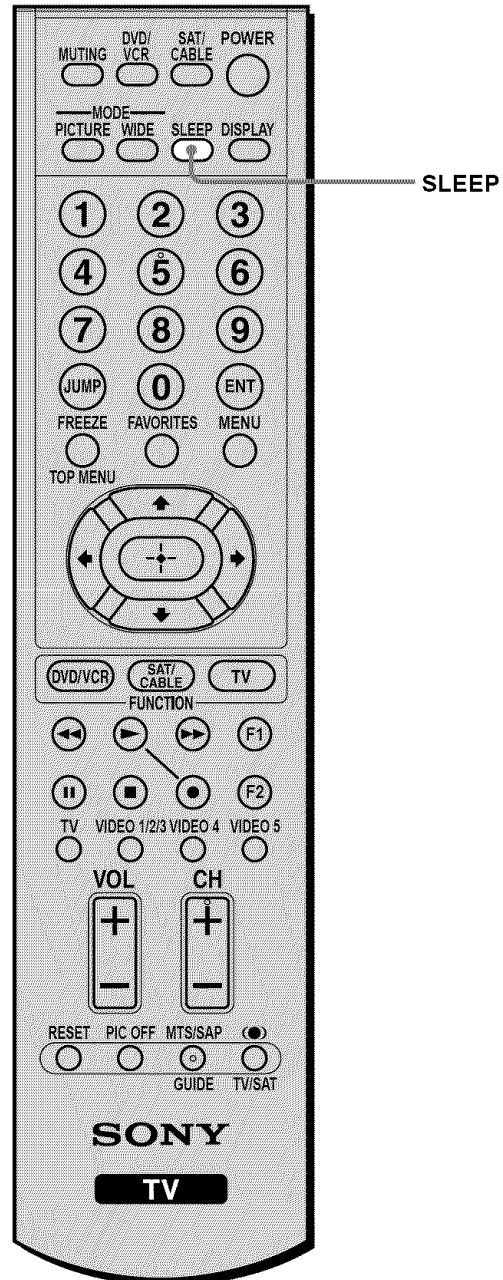

(Continued)

Press SLEEP repeatedly until the desired period of time appears.

Each time you press the button, the period of time changes as follows:

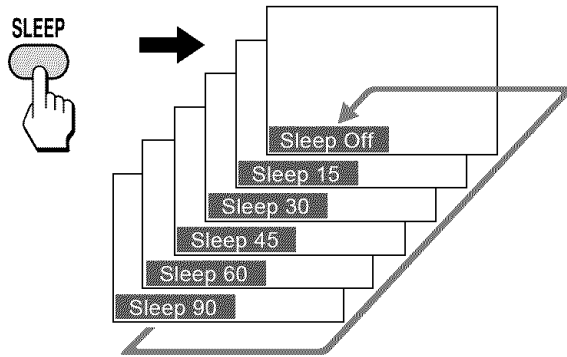

While the Sleep timer is activated, the ⏰ (Timer) LED on the TV lights up in red.

To cancel the Sleep timer

Press SLEEP repeatedly until “Sleep Off” appears.

Tips

- If you turn the TV off, and then turn it on again, the Sleep timer returns to “Sleep Off.”
- “TV will turn off soon” appears one minute before the TV shuts off. This message may not appear if you perform any operation with the menu opened.

Additional Information

Troubleshooting

Self-diagnosis function

The TV is equipped with a self-diagnosis function. If there is a problem with your TV, the  (Power on/Stand by) LED on the front panel will flash repeatedly in red. Writing down the duration of flashes and interval between flashes helps you inform qualified Sony personnel of the TV's condition.

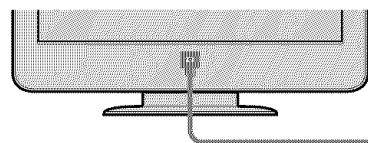





 (Power on/Stand by) LED (flashing in red)









- 1 Measure how long the  (Power on/Stand by) LED flashes and stops flashing.

For example, the LED flashes for 2 seconds, stops flashing for 1 second, and flashes for 2 seconds.

- 2 Press  (Power) on the TV to turn it off, and disconnect the power cord, then inform qualified Sony personnel or the Direct Response Center/ Customer Relations Center of how the indicator flashes (duration and interval).

Trouble symptoms and remedies

Problem	Possible remedies
No picture.	
Cannot receive any channels.	<ul style="list-style-type: none"> • Make sure the power cord is connected securely. • Turn on the power of the TV. • Check antenna/cable connections. • Press PIC OFF on the remote control so that the  (Picture off) LED goes off.
Cannot receive upper channels (UHF) when using an antenna.	<ul style="list-style-type: none"> • Set "Cable" to "Off" in the  (Channel) menu (page 36). • Perform Auto Program to add receivable channels that are not presently in the TV's memory (page 35).
TV is locked to one channel.	<ul style="list-style-type: none"> • Perform Auto Program to add receivable channels that are not presently in the TV's memory (page 35). • Check your Channel Fix setting (page 37).
Cannot receive any channels when using cable TV.	<ul style="list-style-type: none"> • Perform Auto Program to add receivable channels that are not presently in the TV's memory (page 35). • Make sure "Cable" in the  (Channel) menu is set to "On" (page 36).
Cannot receive or select channels.	<ul style="list-style-type: none"> • Perform Auto Program to add receivable channels that are not presently in the TV's memory (page 35).
The TV turns off automatically. (The TV enters the standby mode.)	<ul style="list-style-type: none"> • Check that the Sleep timer is activated (page 75).
Some video sources do not appear.	<ul style="list-style-type: none"> • Check the connection between the optional video equipment and the TV. • Press the Input Select buttons on the remote control (page 52). • When you connect video equipment to both the VIDEO and the S VIDEO input jacks, make sure "Auto YC" in the  (Setup) menu is set to "On" to view the S VIDEO input (page 23).

Problem	Possible remedies
Poor picture.	
Double images or ghosts.	<ul style="list-style-type: none"> • Check antenna/cable connections. • Check the antenna location and direction.
Only snow and noise appear on the screen.	<ul style="list-style-type: none"> • Check if the antenna is broken or bent. • Check if the antenna has reached the end of its serviceable life. (3-5 years in normal use, 1-2 years at the seaside.)
Dotted lines or stripes.	<ul style="list-style-type: none"> • Keep the TV away from noise sources such as cars, motorcycles, or hair-dryers.
No color. Color is not correct. Dark picture.	<ul style="list-style-type: none"> • Press PICTURE to select the desired Picture Mode (page 42). • Adjust the Picture Mode options in the  (Video) menu (page 59).
The picture is too bright.	<ul style="list-style-type: none"> • Press PICTURE to select the desired Picture Mode (page 42).
Picture (stripe) noise.	<ul style="list-style-type: none"> • Make sure that the antenna is connected using the supplied 75-ohm coaxial cable. • Keep the antenna cable away from other connecting cords. • Do not use 300-ohm twin lead cables as interference may occur.
The screen flickers when turning on the TV.	<ul style="list-style-type: none"> • This is caused by feature of the Plasma Display Panel, and does not indicate a malfunction of the TV.
No sound./Noisy sound.	
Good picture, no sound.	<ul style="list-style-type: none"> • Check the volume control. • Press MUTING or VOL + so that “Muting” disappears from the screen (page 40). • Disconnect your headphones. • Set “Speaker” to “On” in the  (Audio) menu (page 64). If it is set to “Off,” sound is not output from the TV’s speakers regardless of the TV’s volume control. • Check if the current input is set to “On” in “Center Speaker Mode” in the  (Audio) menu (page 49).
Audio noise.	<ul style="list-style-type: none"> • Make sure that the antenna is connected using the supplied 75-ohm coaxial cable. • Keep the antenna cable away from other connecting cords. • Do not use 300-ohm twin lead cables as interference may occur. • Press MTS/SAP to select “Mono” (page 62).
Striped noise during playback/recording of a VCR	<ul style="list-style-type: none"> • This is caused by video head interference. Keep your VCR away from the TV. • Leave a space of 30 cm (11 7/8 inches) between your VCR and the TV to avoid noise. • Avoid installing your VCR in front of the TV or at the side of the TV.
Cannot operate the menu.	<ul style="list-style-type: none"> • If the option you want to select appears in a pale color, you cannot select it.
Wide Screen Mode changes automatically.	<ul style="list-style-type: none"> • The current Wide Screen Mode setting is automatically replaced with the 4:3 Default setting when you change the channel or video input, if “4:3 Default” in the  (Screen) menu is set to other than “Off.” If you want to lock in the Wide Screen Mode selected with the WIDE button, set “4:3 Default” to “Off” in the  (Screen) menu (page 47).
Remote control does not operate.	<ul style="list-style-type: none"> • The batteries could be weak. Replace the batteries. • Check the polarity of the batteries. • If the  (Power on/Stand by) LED on the TV does not light in red, press  (Power) on the TV. • Point the remote control at the remote control sensor of the TV. • Install the TV away from fluorescent lights. • Try to press F1 or F2 button on the remote control.
Cannot change channels with the remote control.	<ul style="list-style-type: none"> • Be sure you have not inadvertently switched your TV from channel 3 or 4 setting if you are using another device to change channels. • If you are using another device to control channels, be sure the FUNCTION button for that device has been pressed. For example, if you are using your cable box to control channels, be sure to press SAT/CABLE (page 16).
Lost password.	<ul style="list-style-type: none"> • Select the  (Parent) menu on the menu screen, then enter the following master password: 4357. The master password clears your previous password and allows you to enter a new password (page 67).

Specifications

Television system:

American TV standard

Channel coverage:

VHF: 2-13/UHF: 14-69/CATV: 1-125

Antenna:

75-ohm external terminal for VHF/UHF

Screen size (measured diagonally):

42 inches

Panel System:

Plasma Display Panel

Display resolution:

852 dots (horizontal) × 480 lines (vertical)

VIDEO IN 1/2/3:

S VIDEO (4-pin mini DIN):

Y: 1.0 Vp-p, 75 ohms unbalanced,
sync negative

C: 0.286 Vp-p (Burst signal),
75 ohms

VIDEO: 1 Vp-p, 75 ohms unbalanced,
sync negative

AUDIO: 500 mVrms (100% modulation)
Impedance: 47 kilohms

HD/DVD IN 4:

Y, P_B, P_R (Component Video):

Y: 1.0 Vp-p, 75 ohms
unbalanced, sync negative

P_B: 0.7 Vp-p, 75 ohms

P_R: 0.7 Vp-p, 75 ohms

Signal format:

480i, 480p, 720p, 1080i

AUDIO: 500 mVrms (100% modulation)
Impedance: 47 kilohms

HDMI IN 5:

HDMI: 1 terminal, 3.3 V T.M.D.S.,
50 ohms

The DVI-HDTV input terminals
compliant with the EIA-861B
standard and is not intended for
use with PC.

AUDIO: 500 mVrms (100% modulation)
Impedance: 47 kilohms

AUDIO OUT:

500 mVrms (100% modulation)

More than 1 Vrms at the maximum volume setting
(Variable)

More than 500 mVrms (Fixed)

Headphones:

Stereo mini jack

Impedance: 16 ohms

Speaker:

Full range: \varnothing 7 cm (2)
(2 ⁷/₈ inches) (2)

Woofer: \varnothing 7 cm
(2 ⁷/₈ inches) (2)

Speaker output:

10 W + 10 W

Power requirement:

120 V AC, 60 Hz

Power consumption:

In use: 370 W

In standby: Less than 1 W

Dimensions (W/H/D):

Including TV stand: 1,075 × 826 × 312 mm
(42 ³/₈ × 32 ⁵/₈ × 12 ³/₈ inches)

Without TV stand: 1,075 × 750 × 110 mm
(42 ³/₈ × 29 ⁵/₈ × 4 ³/₈ inches)

Mass:

Including TV stand: 45.0 kg (99 lb. 3 oz.)

Without TV stand: 39.5 kg (87 lb. 1 oz.)

Supplied accessories:

Remote control RM-Y1003 (1)

Size AA batteries (2)

75-ohm coaxial cable (1)

AC power cord (1)

Clamp screws (2)

Plug Holder for AC Power Cord (1)

Cleaning Cloth (1)

Operating Instructions (1)

Quick Setup Guide (1)

Warranty Card (1)

Optional accessories:

Note that some optional accessories may be out of
stock.

Headphones plug adaptor

Connecting cables

Wall-Mount Bracket SU-PW2

Design and specifications are subject to change
without notice.

Index

- 4:3 Default 47
- A**
- Adjusting
- picture position 57, 58
 - picture quality 59
 - sound quality 61
 - volume 40
- Audio Out 26, 64
- Auto Program 35
- Auto SAP 62
- Auto YC 23
- C**
- Cable TV 35
- Center speaker 49
- Channel setting 35
- Channel Fix 37
 - Channel Label 55
 - Channel Skip/Add 36
- Closed caption 41
- Component Video connectors 27, 28, 29
- Connecting 21
- antenna 21
 - audio receiver 26
 - AV receiver 33
 - cable box 21
 - digital cable box 29
 - digital satellite receiver 30, 31
 - DVD player 27, 28
 - power cord 22
 - satellite receiver 24, 25
 - VCR 23
- D**
- DISPLAY 40
- E**
- Effect 43
- F**
- Favorite channels 54
- Front and rear connectors 18
- Full 45
- H**
- H Center 58
- I**
- Input select 52
- J**
- JUMP 40
- L**
- Language selection 38
- M**
- Menu 37
- Mild Mode 60
- Mono 62
- MTS/SAP 62
- MUTING 40
- N**
- Noise Reduction 60
- Normal 45
- P**
- Parent 65
- password 66, 67
 - ratings 68
- Picture Mode 42
- PIC OFF 48
- Power on/off 40
- Pro 42
- R**
- Remote control 11
- battery installation 11
 - programming 14
 - using with other equipment 16
- S**
- S Video input jack 23
- Self-diagnosis function 77
- Sleep timer 75
- Speaker 26, 65
- Specifications 79
- SRS 43
- Standard 42
- Stereo 62
- T**
- TruSurround 43
- Troubleshooting 77
- U**
- Unpacking 11
- V**
- V Center 57
- VHF/UHF channels 36
- Video label 53
- Vivid 42
- Volume 40
- W**
- Wide Screen Mode 44
- Wide Mode 47
- Wide Zoom 45
- Z**
- Zoom 45

<http://www.sony.net/>



Printed on 100% recycled paper.

Printed in Japan