

Owner's Manual

CRAFTSMAN®

48" DOZER BLADE

Model No. 486.244122

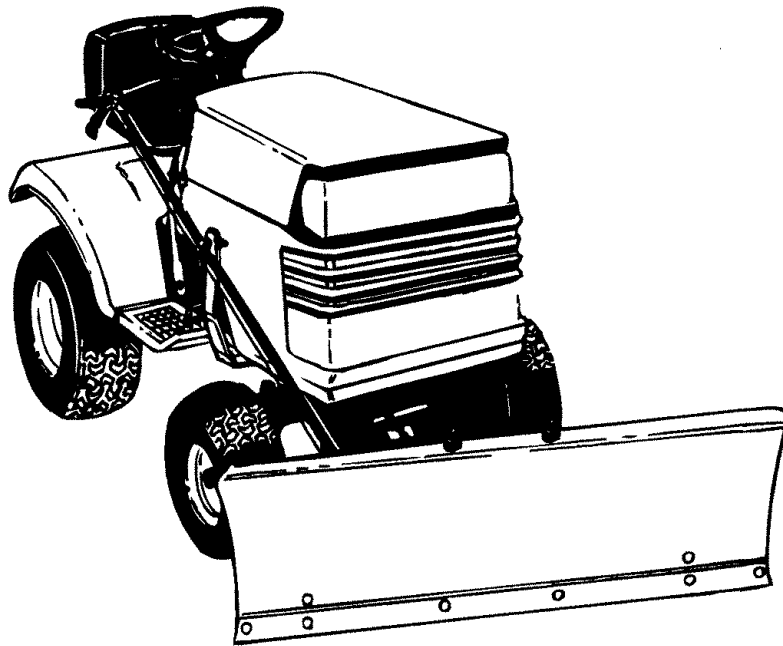

CAUTION:

Before using this product, read this manual and follow all Safety Rules and Operating Instructions.

- Safety
- Assembly
- Operation
- Maintenance
- Parts

IMPORTANT - READ THIS FIRST!!!

For Missing Parts or Assembly Questions

Please Call 866-576-8388

Mon.-Fri. 7 am - 5 pm CST.

FAX 217-728-2032 or e-mail info@agri-fab.com

Missing parts will be sent UPS in 24 hours directly to your home.

Sears, Roebuck and Co., Hoffman Estates, IL 60179 U.S.A.

www.sears.com/craftsman

PRINTED IN U.S.A.

FORM NO. 49344 (5/04)

SAFETY

Any power equipment can cause injury if operated improperly or if the user does not understand how to operate the equipment. Exercise caution at all times, when using power equipment.

1. Read the tractor and dozer blade owners manuals and know how to operate your tractor before using the tractor with the dozer blade attachment.
2. Never operate the tractor and dozer blade without wearing proper clothing suited to weather conditions and operation of controls.
3. Never allow children to operate the tractor and dozer blade. Do not allow adults to operate without proper instructions.
4. Always begin with transmission in first (low) gear and gradually increase speed as required.



Look for this symbol to point out important safety precautions. It mean--**Attention!!**
Become alert!! Your safety is involved.

LIMITED ONE YEAR WARRANTY ON 48" DOZER BLADE

For one year from the date of purchase, when this Dozer Blade is maintained and lubricated according to the operating and maintenance instructions in the owner's manual, Sears will repair any defect in material or workmanship free of charge. If this Dozer Blade is used for commercial or rental purposes, this warranty applies for only 90 days from the date of purchase.

This warranty does not cover repairs necessary because of operator negligence or abuse, including the failure to maintain the equipment according to instructions contained in the owner's manual.

WARRANTY SERVICE IS AVAILABLE BY CONTACTING THE NEAREST SEARS SERVICE CENTER/DEPARTMENT IN THE UNITED STATES.

This warranty applies only while this product is in the United States.

This warranty gives you specific legal rights, and you may also have other rights which vary from state to state. Sears, Roebuck and Co. D/817 WA. Hoffman Estates, Chicago, IL 60179

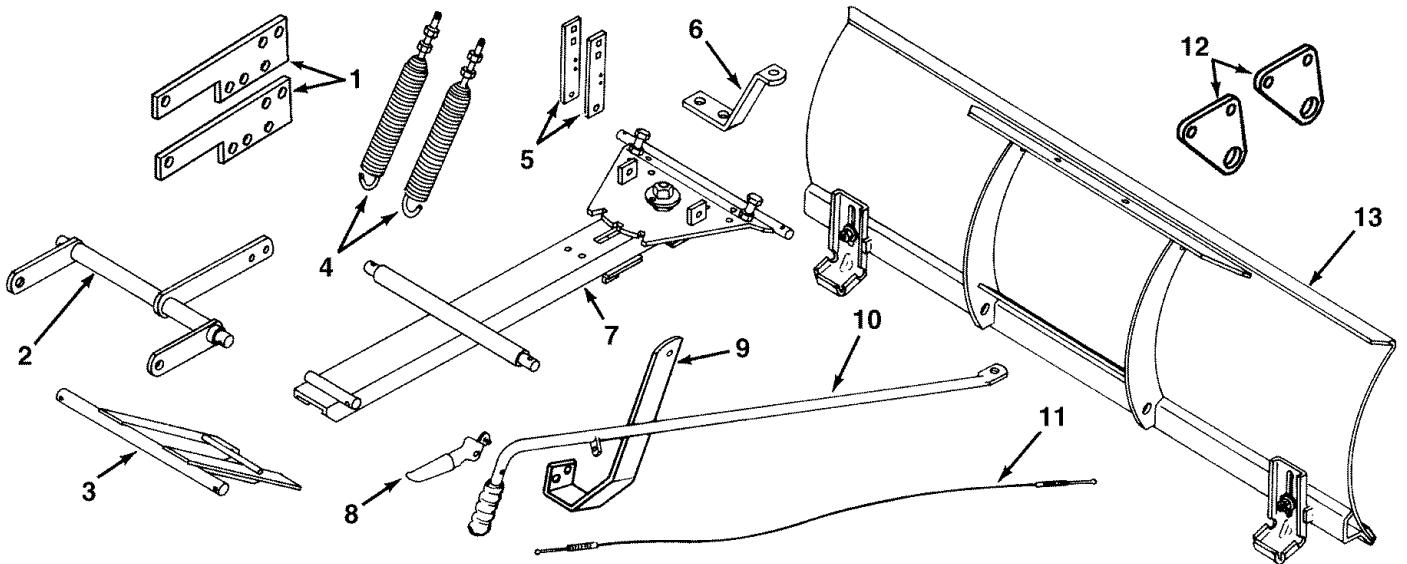

CARTON CONTENTS

- | | | |
|---------------------------|---------------------------------|----------------------------|
| 1. Frame Brackets | 6. Blade Pivot Bracket | 11. Control Cable Assembly |
| 2. Lift Assembly | 7. Channel/Pivot Plate Assembly | 12. Lift Pivot Plate (2) |
| 3. Guide Bracket Assembly | 8. Grip Assembly | 13. Blade Assembly |
| 4. Spring Assembly (2) | 9. Support Bracket | Parts Package (See page 3) |
| 5. Angle Lock Bars (2) | 10. Handle Assembly w/Grip | |

SHOWN FULL SIZE

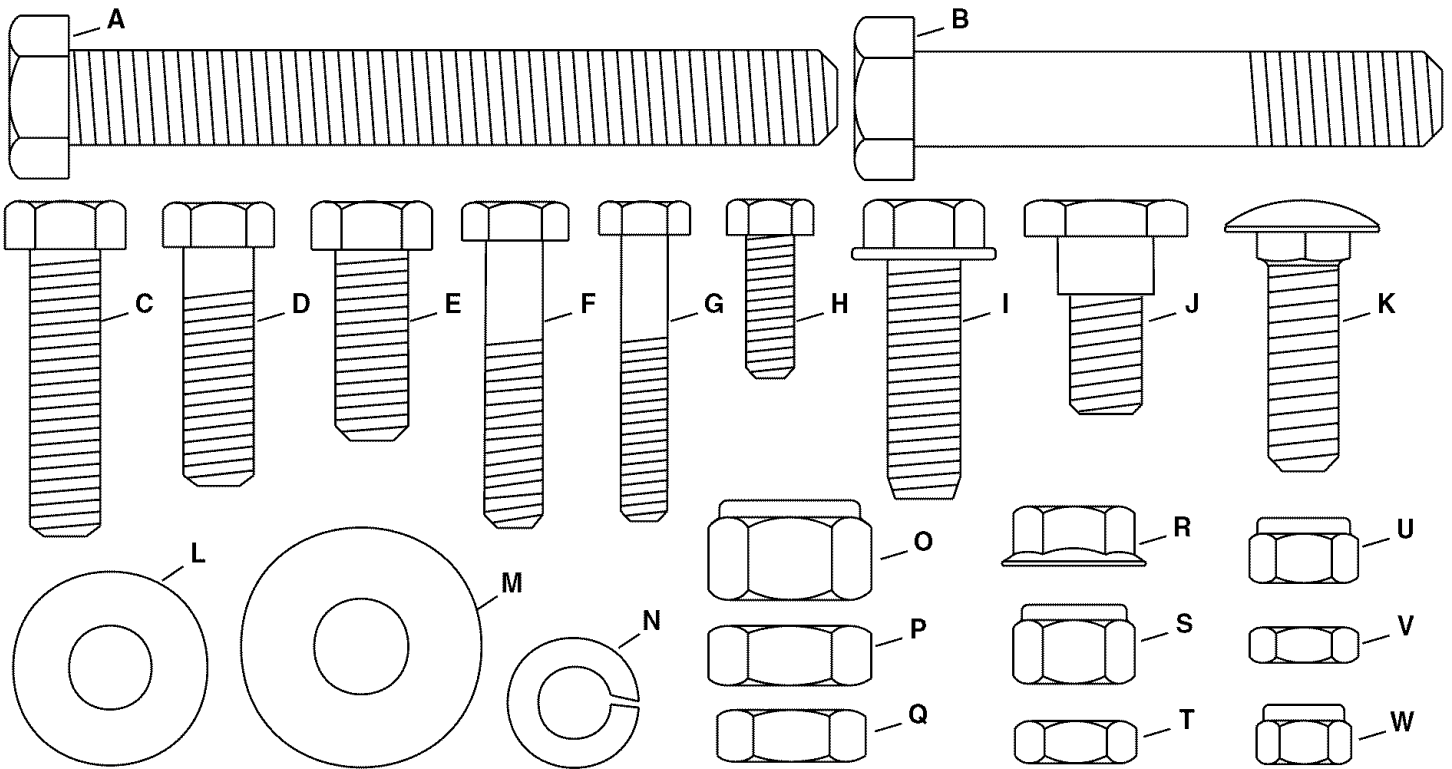

NOT SHOWN FULL SIZE

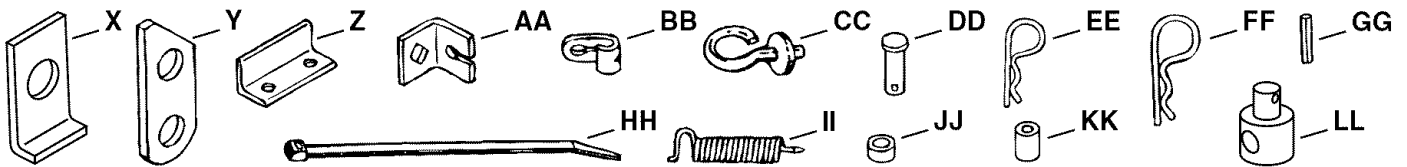

CONTENTS OF PARTS PACKAGE

REF.	QTY.	DESCRIPTION	REF.	QTY.	DESCRIPTION
A	1	Hex Bolt, 1/2" x 4"	T	2	Hex Jam Nut, 3/8"
B	2	Hex Bolt, 1/2" x 2-3/4"	U	1	Nyock Nut, 5/16"
C	4	Hex Bolt, 3/8" x 1-1/2"	V	4	Hex Jam Nut, 5/16"
D	5	Hex Bolt, 3/8" x 1-1/4"	W	3	Nyock Nut, 1/4"
E	1	Hex Bolt, 3/8" x 1"	X	2	Keeper Plate
F	1	Hex Bolt, 5/16" x 1-1/2"	Y	1	Lift Arm Link
G	1	Hex Bolt, 1/4" x 1-1/2"	Z	1	Stop Angle
H	1	Hex Bolt, 1/4" x 3/4"	AA	1	Cable Mount Bracket
I	2	Hex Bolt, 3/8" x 1" Thread Forming	BB	2	Cable End Fitting
J	1	Shoulder Bolt, (Special) 3/8" x 5/8"	CC	1	Handle Guide
K	2	Carriage Bolt, 3/8" x 1-1/4"	DD	4	Clevis Pin, 3/8" x 3/4"
L	1	Flat Washer, 3/8" Std.	EE	6	Hairpin Cotter, 3/32"
M	4	Flat Washer, 7/16" Std.	FF	10	Hairpin Cotter, 1/8"
N	4	Lock Washer, 3/8"	GG	1	Spring Pin, 1/4" x 1"
O	2	Nylock Nut, 1/2"	HH	1	Nylon Tie
P	2	Hex Jam Nut, 1/2"	II	1	Spring, Angle Lock
Q	4	Hex Jam Nut, 7/16"	JJ	9	Spacer, Short
R	1	Whizlock Nut, 3/8"	KK	1	Spacer, Long
S	10	NyLock Nut, 3/8"	LL	2	Trunnion, Lift Rod

ASSEMBLY INSTRUCTIONS

TOOLS REQUIRED FOR ASSEMBLY

- (1) 7/16" Open End or Box Wrench
- (1) 1/2" Open End or Box Wrench
- (1) 9/16" Open End or Box Wrench
- (1) 3/4" Open End or Box Wrench
- (1) Adjustable Wrench
- (1) Hammer

Refer to carton contents figure on page 2 and figure 1 on page 3 for parts and hardware needed to assemble dozer blade.



NOTE

RIGHT HAND (R.H.) AND LEFT HAND (L.H.) ARE DETERMINED FROM OPERATOR'S POSITION WHILE SEATED ON TRACTOR.

1. Assemble curved end of angle lock spring into small hole in washer as shown in figure 2.

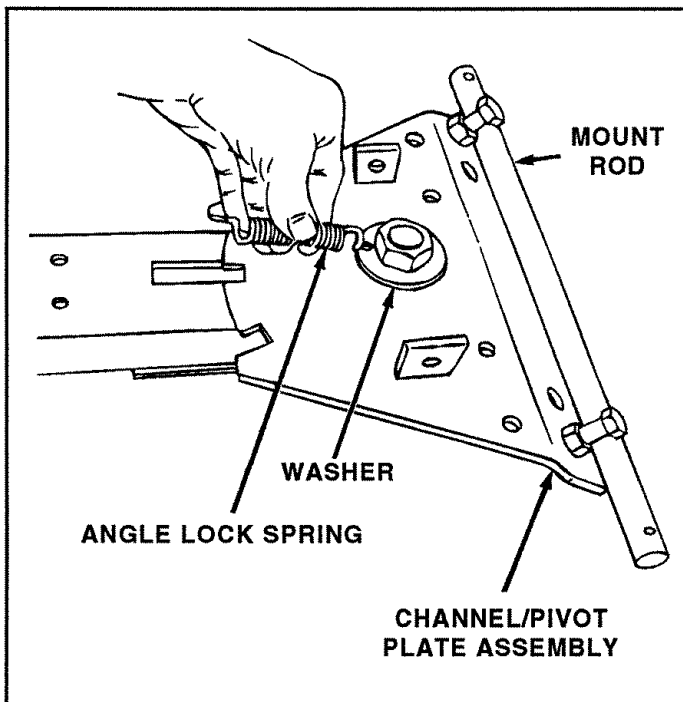

FIGURE 2

2. Assemble the two angle lock bars together as shown in figure 3, using one 3/8" x 1-1/4" carriage bolt and a 3/8" nylock nut in the top holes. Do not tighten at this time.

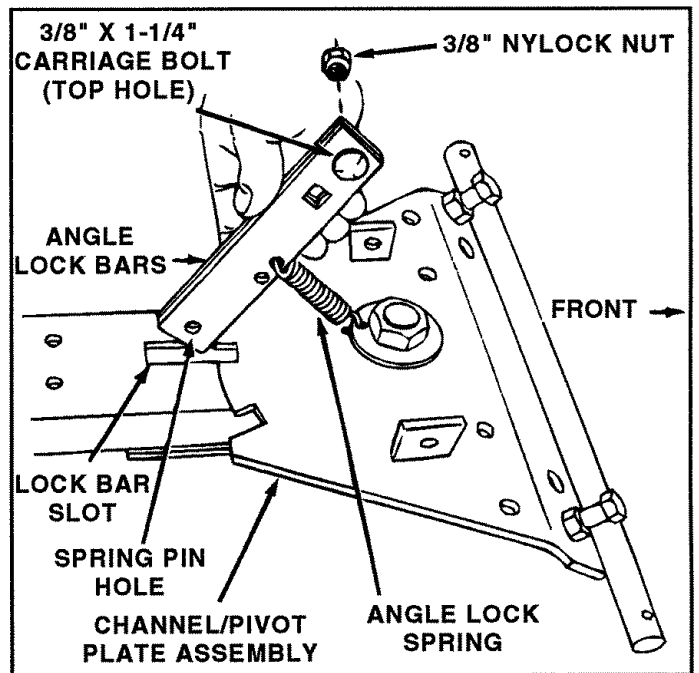

FIGURE 3

3. Assemble the offset end of angle lock spring into small holes in angle lock bars as shown in figure 3. Slide lock bars through lock bar slot until spring pin hole is aligned with bracket on back side. See figure 4. Using a hammer drive 1/4" x 1" spring pin into lock bars until flush with bracket. See figure 4. Tighten nut in angle lock bars which was left loose in step 2.

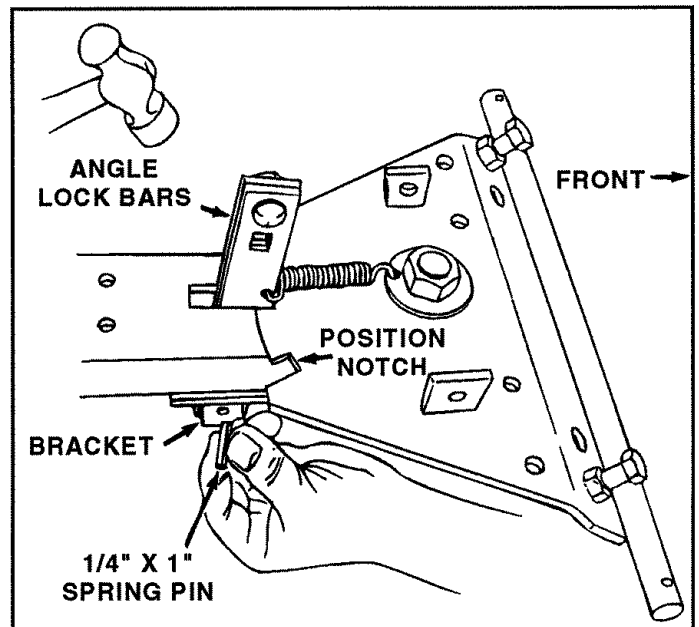

FIGURE 4



NOTE

Lock bars should pivot freely and when pulled all the way back the channel/pivot plate assembly should be unlocked and free to pivot to right or left position notches.

- Assemble angle stop to top of channel using one 1/4" x 3/4" hex bolt down through left hand hole, and one 1/4" nylock nut under channel. See figure 5. **Do not tighten at this time.**

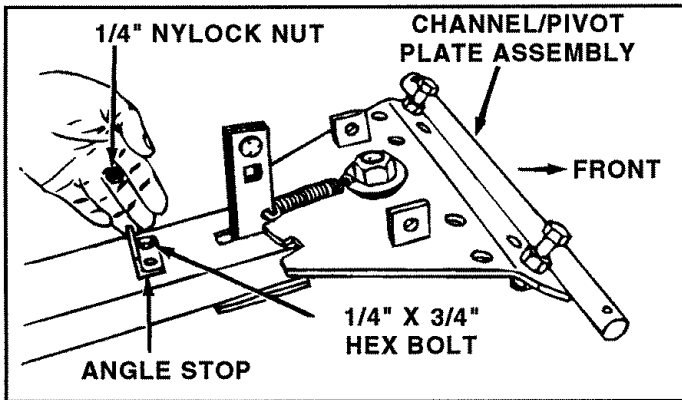

FIGURE 5

- Assemble 3/8" x 1-1/4" carriage bolt through square hole in cable mount bracket and through square hole in lock bars. See figures 6 and 7. Hold cable mount bracket in position as shown in figure 7 and secure with a 3/8" nylock nut.

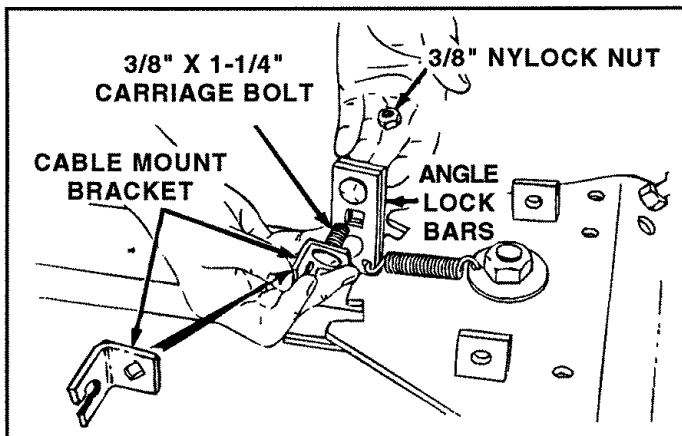

FIGURE 6

- Assemble one 5/16-24 hex jam nut onto threaded end of control cable approximately 3/4" from end. Assemble threaded cable end through round hole in cable mount bracket and secure with another 5/16-24 hex jam nut. See figure 7.

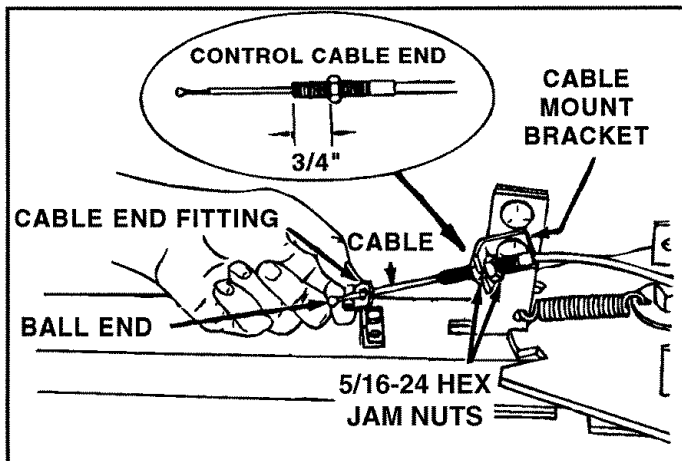

FIGURE 7

- Assemble ball end of cable through round hole in cable end fitting and into slot of fitting. See figures 7 and 8.
- Attach cable end fitting and long spacer to right hand hole in angle stop and channel using 1/4" x 1-1/2" hex bolt and 1/4" Nylock nut. **Tighten both 1/4" Nylock nuts that secure the angle stop to the channel. See figure 8. NOTE: Keep cable and fitting in alignment with cable mount bracket when tightening nuts.**

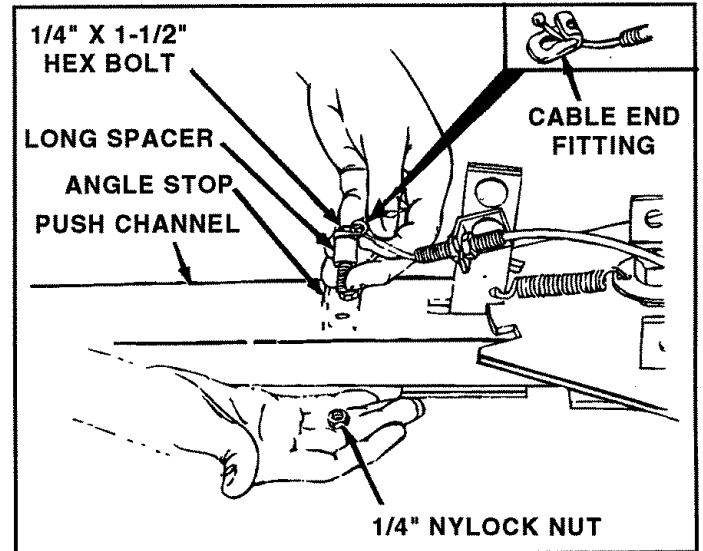

FIGURE 8

ASSEMBLY OF BLADE TO TRACTOR

TO PREPARE TRACTOR:

- Remove the mower or any other attachment you may have mounted to your tractor. Mark all loose parts and save for re-assembly. Refer to tractor owners manual for instructions on removal of the mower or attachment.
- Remove and save both suspension arms, along with the nuts and washers which fasten them to the lift link rods. Also remove the 3/8" self-tapping bolts from each side of the tractor frame as shown in figure 9. **On some tractors the lift link nuts will be reused to fasten the dozer blade lift assembly to the lift link rods.**

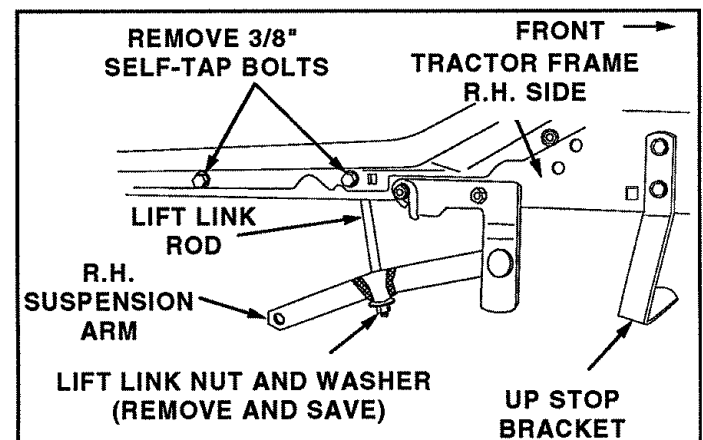

FIGURE 9

1. Assemble one 1/2" x 4" hex bolt, one 1/2" jam nut and one 7/16" standard washer into top of slotted hole in channel assembly. Assemble one 7/16" standard washer and one 1/2" jam nut on bottom of 1/2" bolt under channel assembly. See figure 10. **DO NOT TIGHTEN AT THIS TIME.**
2. Assemble channel assembly to hitch plates at front of tractor as shown in figures 10 and 11.

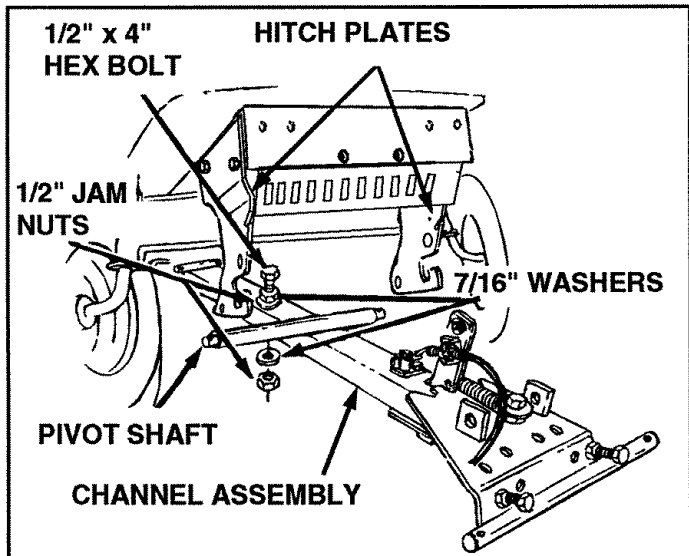

FIGURE 10

3. Assemble keeper plates over each end of pivot shaft with lip under hitch plates (see figure 11) and secure with two 1/8" (large) hairpin cotters through small holes near each end of shaft.

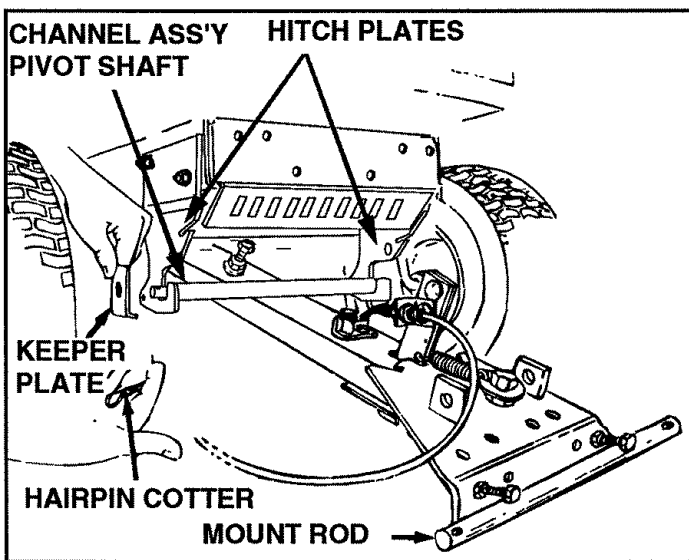

FIGURE 11

4. Adjust 1/2" x 4" stop bolt, previously assembled into channel assembly (step 1). See figure 12. Adjust jam nuts, above and below channel, to provide a **minimum 1/8" clearance** between channel and the tractor engine pulley with the stop bolt positioned against front axle frame member. See figure 12.



The stop bolt must be located so that **CENTER** of bolt contacts the front axle. The stop bolt must be tightened in place before assembling blade assembly to channel.

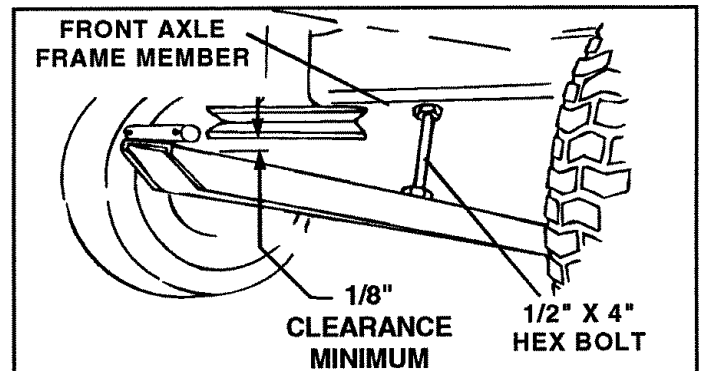

FIGURE 12

5. Hold blade head upright and guide one end of mount rod into hole near bottom of blade mount gusset. See figures 11 and 13. Secure with a hairpin cotter. Slide other end of mount rod into other blade mount gusset hole and secure with hairpin cotter.
6. Connect curved end of spring assemblies into spring mount ears. See figure 13. Remove plastic cap and one 3/8" hex nut from end of each spring assembly. Hold blade back against stop bolts and assemble spring adjustment bolts up through bar. Re-assemble two 3/8" hex nuts, removed earlier, onto adjustment bolts on top side of bar. Tighten both spring adjustment nuts approximately 1" down from end of bolt threads, see figure 13, to provide tension of blade against stop bolts.
7. Adjust stop bolts to tilt blade forward until 1-1/2" distance is obtained between pivot plate and blade assembly crossmember. See figure 13.

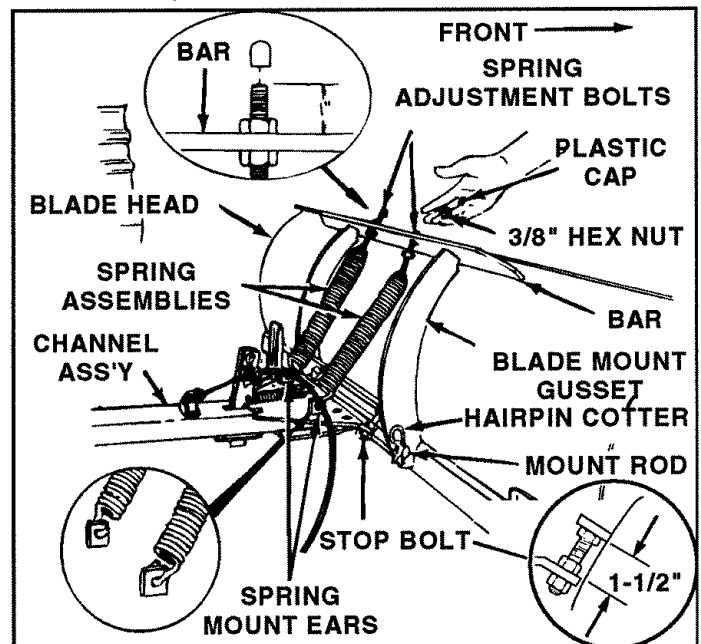

FIGURE 13

- Re-assemble plastic caps on top ends of spring adjustment bolts.



SEE ADJUSTMENT SECTION ON PAGE 10 FOR SPRING TENSION.

- Assemble blade pivot bracket on to top right hand side of channel/pivot assembly. See figure 14. Assemble two 3/8" x 1-1/4" hex bolts down through bracket and plate and secure with two 3/8" nylock nuts underneath.

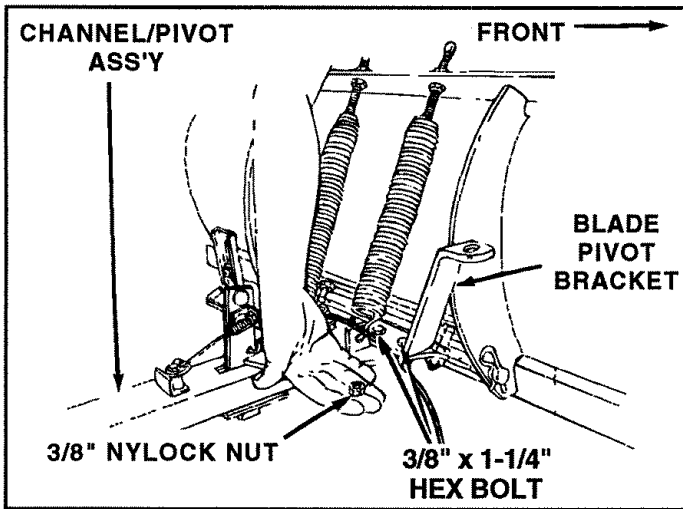

FIGURE 14

- Assemble a frame bracket to the outside of the tractor frame under the left foot rest. Use two 3/8" x 1-1/2" hex bolts, two 3/8" lock washers and four short spacers. Use two spacers on each bolt, between the frame bracket and the tractor frame. Use only one spacer on the rear bolt if it goes through a sway bar bracket. See figure 15.

- Assemble the lift pivot plate to the inside of the frame bracket using two 3/8" x 3/4" clevis pins and two small hairpin cotters. See figure 15.

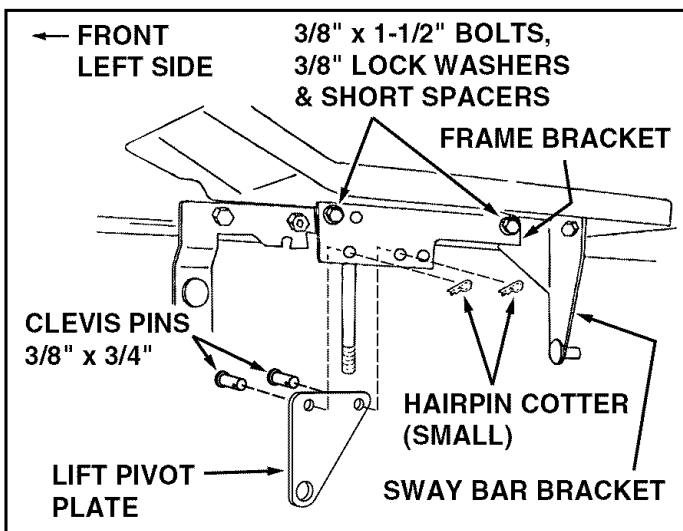

FIGURE 15

- Assemble a lift rod trunnion (facing in) to each lift link rod using either a, b or c:
 - two 7/16-20 hex jam nuts (48" mower decks)
 - a 3/8-16 Nylock nut and the original lock nut you removed earlier (models before 1995).
 - a 3/8-24 hex jam nut and the original lock nut you removed earlier (all other models)

The correct nuts will screw on easily. Tighten nuts so that one thread of rod extends past bottom nut.

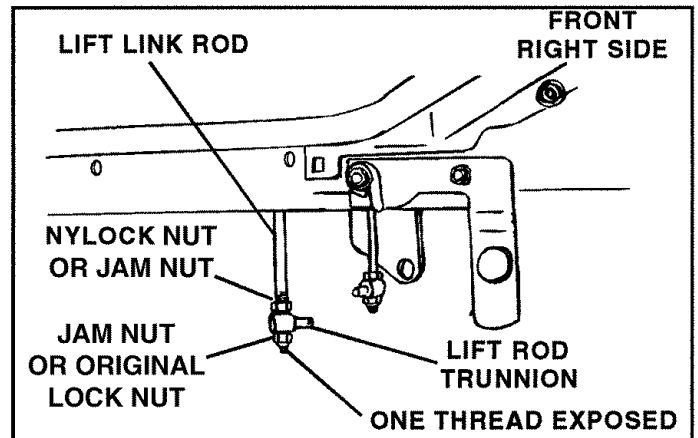

FIGURE 16

- Pre-assemble lift arm link to inside of long arm on lift assembly. As shown in figure 17.

- Assemble one 3/8" x 1-1/4" hex bolt through 3/8" flat washer, through short spacer, through large hole in lift arm link near angle end and through hole in long arm nearest the end. Secure with one 3/8" nylock nut. See figure 17.

NOTE: Lift arm link must pivot freely.

- Assemble one 3/8" x 1" hex bolt through second hole from end of long arm. Secure with one 3/8" nylock nut. This bolt is used as a limit stop for the lift arm link. See figure 17.

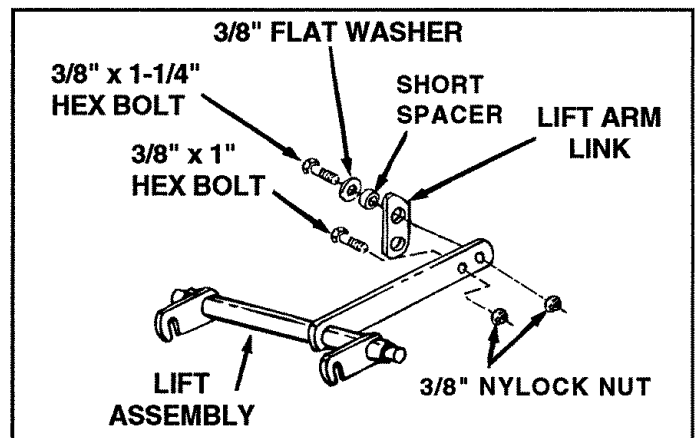

FIGURE 17



Lift arm link must be positioned as shown in figures 17 and 19.

16. If your tractor does not have an attachment lift spring, skip to next paragraph.

Relieve spring tension on lift lever (see figure 18 and note below) loosening hex jam nut and unscrewing adjustment bolt counter-clockwise to obtain 1/4" clearance between bracket and adjustment bolt.



Tractor lift lever must be positioned all the way back and locked in position.

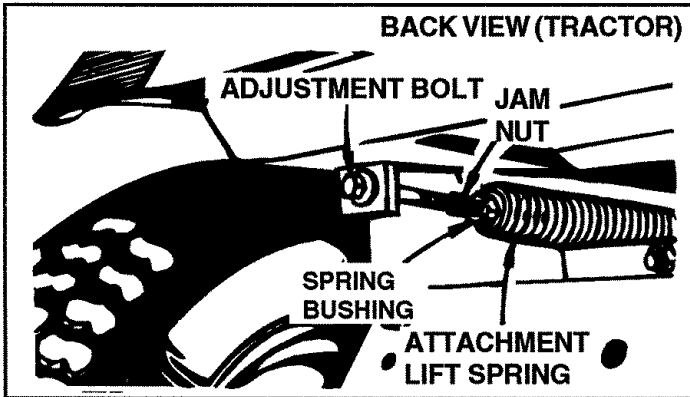

FIGURE 18

17. Move attachment lift lever all the way forward and lock in position. See figure 28 on page 10.

18. Assemble lift arm link over channel rod and insert pivot shaft end (from R.H. side of tractor) into hole in L.H. lift pivot plate. Secure lift arm link to channel rod with 1/8" (large) hairpin cotter. See figure 19.

19. Assemble a frame bracket under the right hand foot rest of the tractor using two 3/8" x 1-1/2" hex bolts, two 3/8" lock washers and four short spacers. Use two spacers on each bolt, between the frame bracket and the tractor frame. See figure 19.

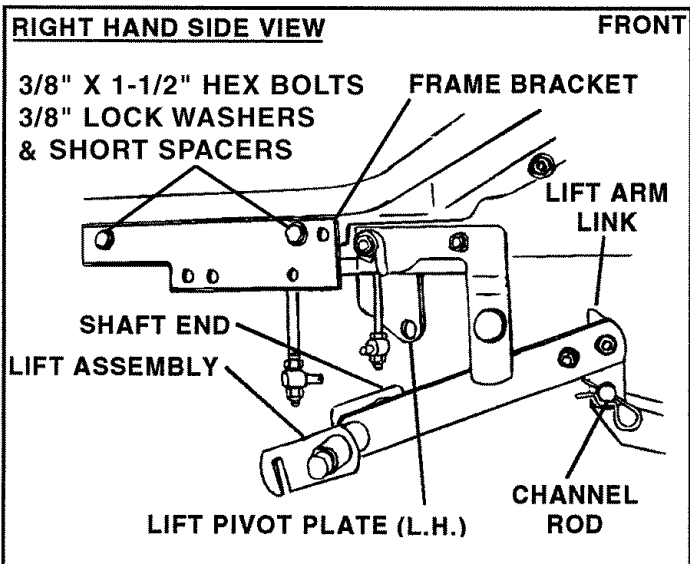

FIGURE 19

20. Assemble trunnions that were assembled to the lift link rods in step 12, through lift assembly arms and secure with 7/16" flat washers and (small) hairpin cotters. **Note: Trunnions must be positioned to outside of lift assembly arms.** See figure 20.

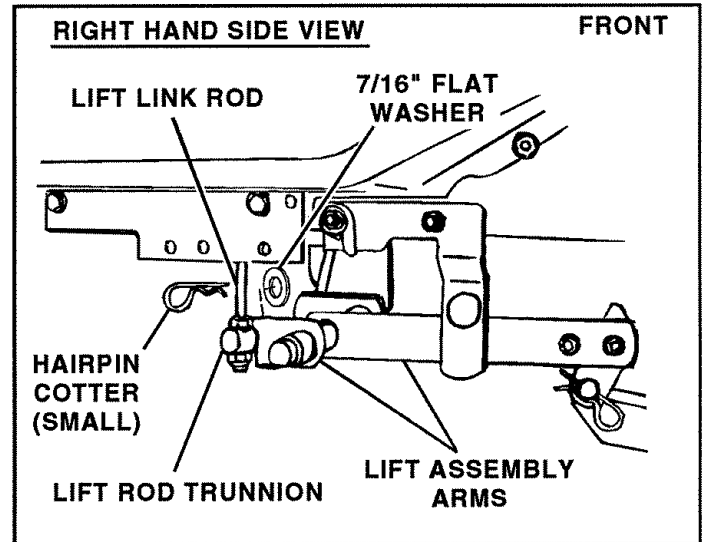

FIGURE 20

21. Assemble lift pivot plate over right hand end of lift assembly pivot shaft and connect to inside of frame bracket using two 3/8" x 3/4" clevis pins from inside. Secure with two 3/32" (small) hairpin cotters. Secure ends of pivot shaft to each lift pivot plate with 1/8" (large) hairpin cotter. See figures 20 and 21.

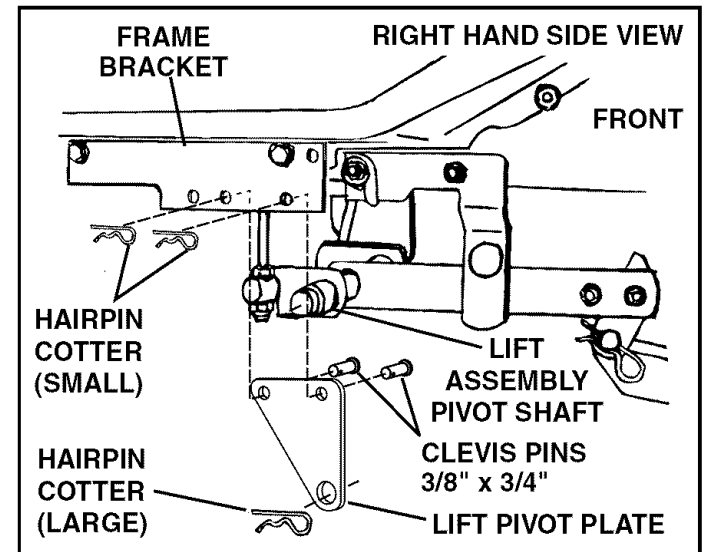

FIGURE 21

22. Align two front holes in Support Bracket with holes in front of foot rest on right side of tractor frame. Remove any bolts present in holes, but leave all brackets in place. Attach the Support Bracket using two 3/8" x 1-1/4" hex bolts and 3/8" Nylock nuts. If bolts won't fit, use 3/8" x 1" thread forming bolts without the Nylock nuts. See figure 22.

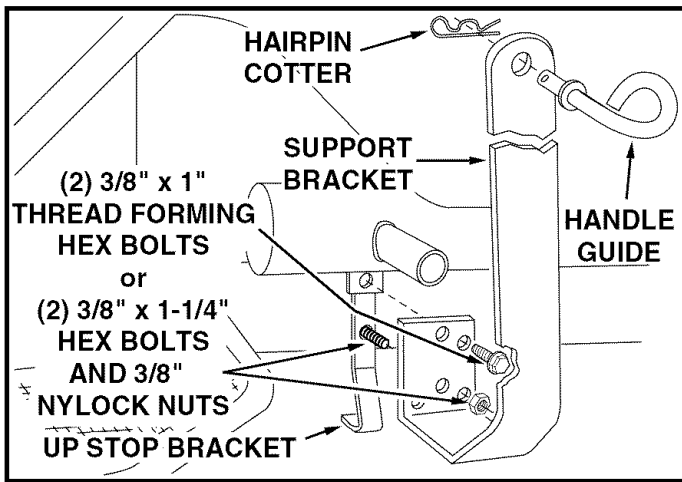

FIGURE 22

23. Assemble handle guide (with loop outside) at top of support bracket and secure with one hairpin cotter (large) inside. See figures 22 and 23.

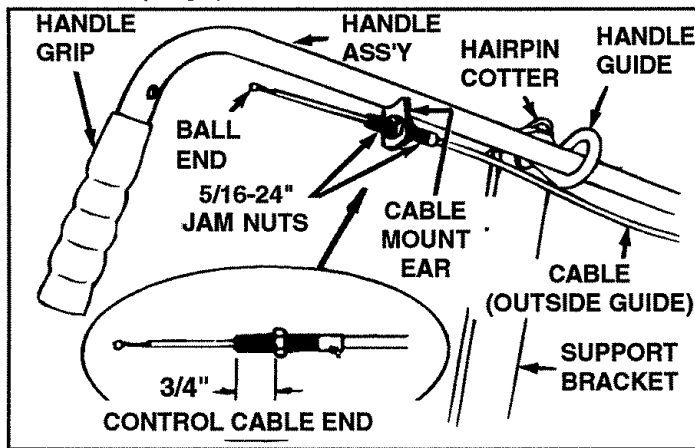

FIGURE 23

24. Assemble handle assembly down through handle guide as shown in figure 23. Secure lower end of handle to top side of blade pivot bracket with special shoulder bolt (on top) and 3/8 inch hex whizlock nut underneath. See figure 24.
25. Assemble one 5/16-24 inch jam nut onto threaded end of control cable approximately 3/4 inch from end. Assemble threaded end of cable up through cable mount ear and secure with second 5/16-24 inch jam nut. See figure 23.
26. Assemble handle grip onto end of handle if not already pre-assembled. See figure 23.

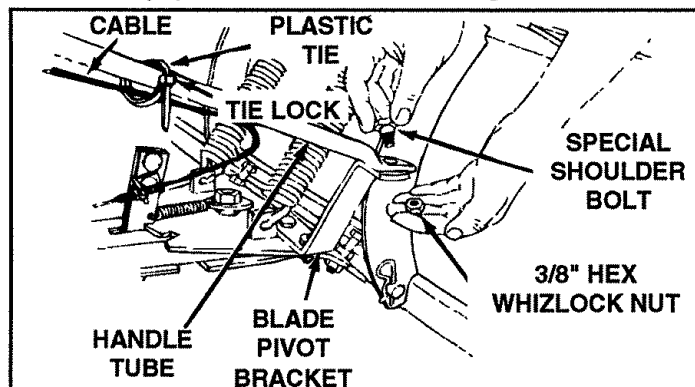

FIGURE 24

27. Wrap plastic tie around handle tube and cable, (see figure 24), assembling end of tie through lock. Pull plastic tie tight to retain cable to handle tube near front of tractor hood. Cut off extra plastic end.
28. Assemble grip assembly to handle assembly using one 5/16 inch x 1-1/2 inch hex bolt and one 5/16 inch nylock nut. **NOTE: Do not over tighten Nylock nut, grip assembly must pivot freely.**

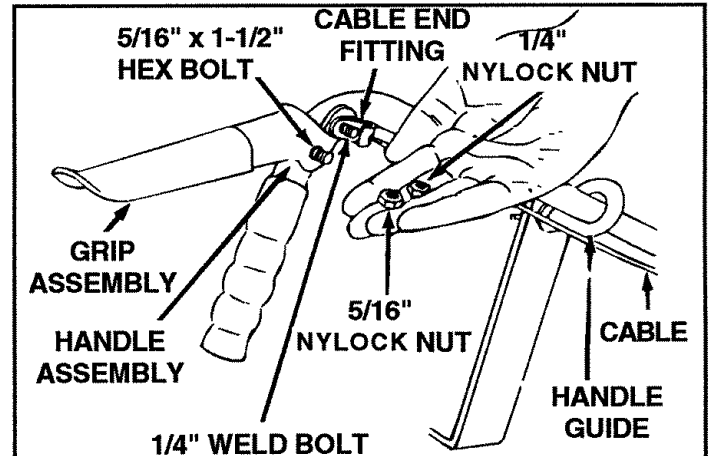

FIGURE 25

29. Assemble ball end of cable (see figure 23), through round hole in cable end fitting and into slot of fitting. See figure 25. Assemble cable end fitting over 1/4 inch weld bolt on grip assembly and secure with one 1/4 inch nylock nut. **NOTE: Do not over tighten lock nut, cable fitting must pivot freely.**
30. Assemble guide bracket assembly shaft end into the left hand hitch plate. See figure 26. Slide guide assembly back to the right and into the hole in the right hand hitch plate.

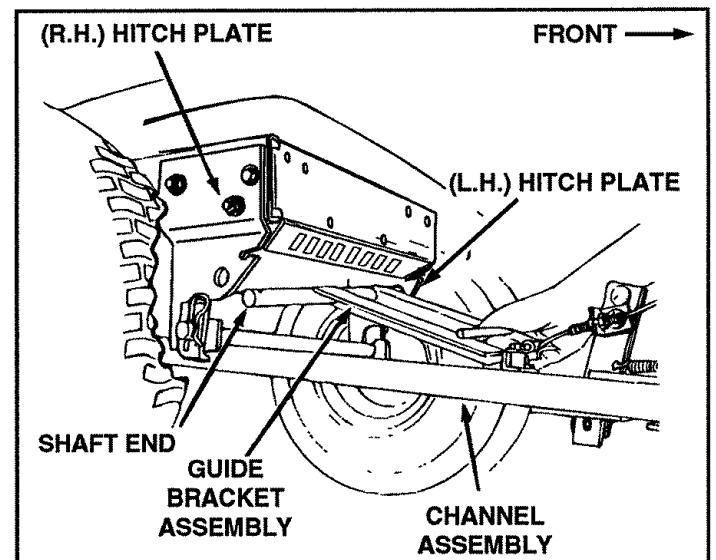

FIGURE 26

31. Secure the guide bracket assembly shaft with a hairpin cotter on each end. See figure 27. Lower front end of guide bracket assembly to straddle channel assembly. See figure 27.

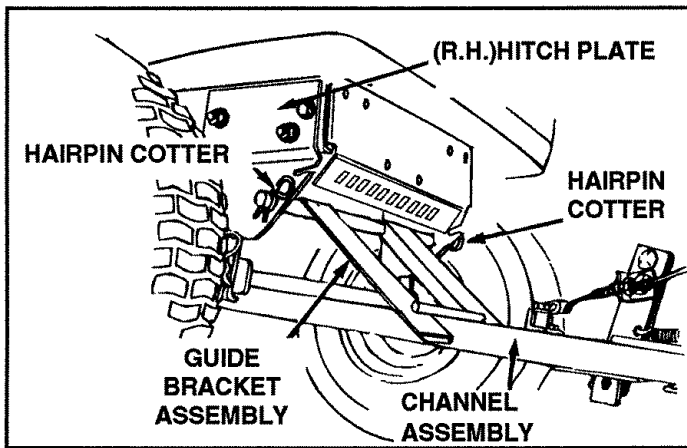
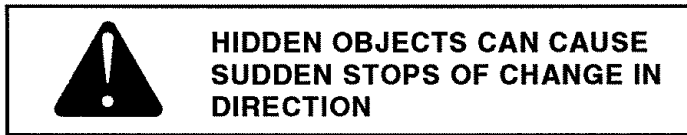

FIGURE 27

OPERATION INSTRUCTIONS AND ADJUSTMENTS



CONTROLS

Become familiar with all of the controls and adjustments on the tractor and dozer blade before operating. Refer to tractor owners manual for tractor controls. Controls for operating dozer blade are as follows:

A. LIFT CONTROL LEVER:

Located on right hand side of tractor. See figure 28. Move lever forward to lower dozer blade. Pull lever back to raise dozer blade. Pulling lever all the way back locks dozer blade in up position.

B. LIFT LEVER PLUNGER:

Located on top of lift control lever. See figure 28. Pull back on lift control lever and depress plunger to release.

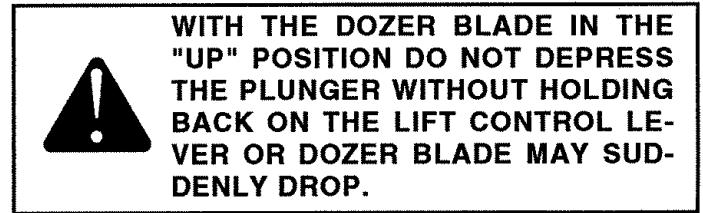

C. Attachment depth control knob:

Adjust lift control lever movement with attachment **DEPTH CONTROL KNOB** (see figure 28) for **maximum movement** between locking notches and to prevent lever from locking in the down lock notch. See figure 28.

D. Blade angle handle and grip assembly:

Located on right hand side of tractor. See figure 28. **NOTE: Always raise dozer blade and lock in "up" position before moving angle control handle.** Depress grip assembly to release blade angle lock and push/pull **angle control handle** forward to move dozer blade angle to left, center, right and release grip to lock.

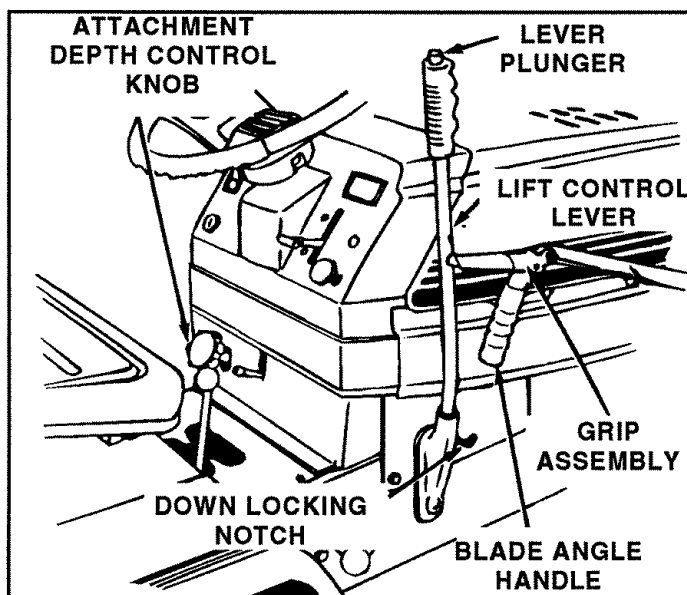

FIGURE 28

ADJUSTMENTS

A. Blade angle lock bars.

If angle lock bars Do Not completely disengage from slots in pivot plate assembly, adjustment of cable is required. See figure 29.

B. Adjust blade springs:

To change spring tension (stand in front of blade assembly), adjust the nuts at the upper end of the springs (see figure 29) turning counter clockwise to relieve tension and clockwise to increase tension.

Adjust spring adjustment nuts approximately 1" from end when moving snow or other light material, **(keep spring tension light for safety)**. This frees the blade to spring trip and return if a hidden obstacle is encountered.

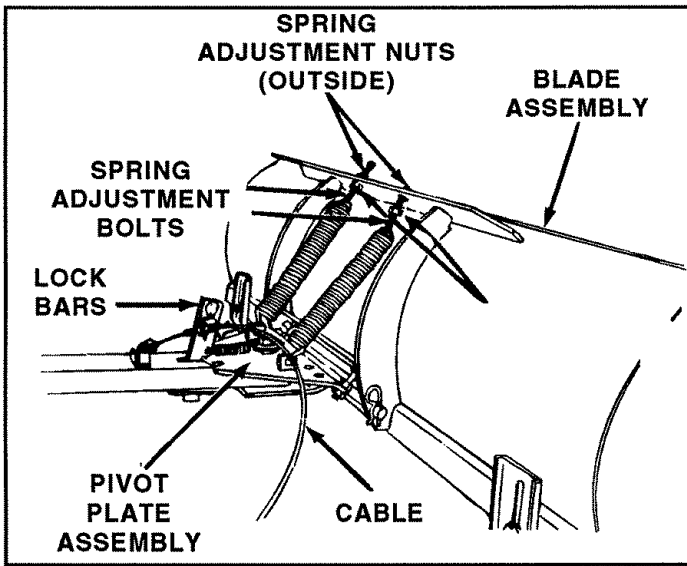

FIGURE 29

D. Blade shoe adjustment:

Blade shoes on end of blade, (see figure 31), maybe raised for clean dozing on smooth surfaces or lowered to raise the blade to work on rough or uneven areas. Make sure both shoes are set evenly and nuts are tightened securely.

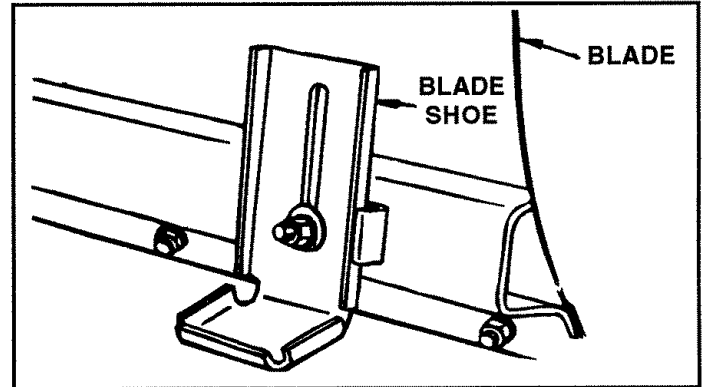

FIGURE 31



KNOW THE TERRAIN. AVOID EXCEPTIONALLY SHARP SLOPES OR DROP-OFFS WHICH MAY BE HIDDEN BY THE SNOW. NEVER RUN THE DOZER BLADE INTO HEAVY MATERIAL AT HIGH SPEED.

C. Dozer spring lockout:

To lock dozer blade spring trip action for heavy dozer work, install two 1/2" x 2-3/4" hex bolts (included in hardware package) as shown in figure 30. Secure with two 1/2" nylock nuts.

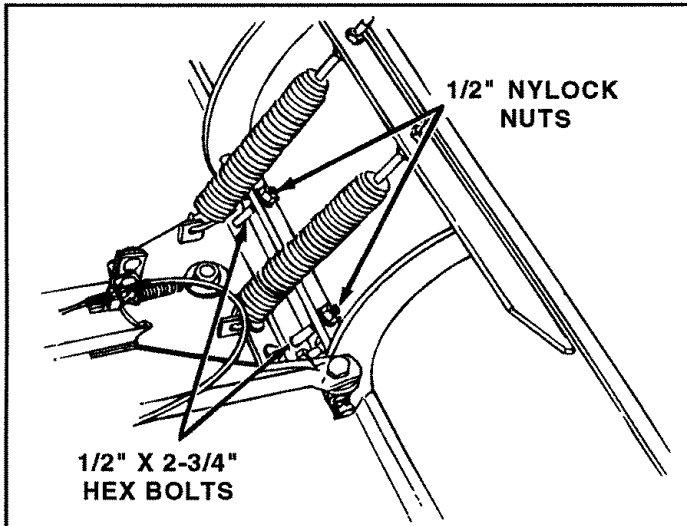

FIGURE 30



Wheel weights and tire chains should be used with your dozer to improve traction. For additional traction, install wheel weight on rear of drawbar using a weight bracket kit and one wheel weight from the wheel weight kit.

These accessories are available at your nearest Sears retail or catalog store.

OPERATION



INSPECT THE AREA TO BE WORKED CAREFULLY BEFORE OPERATING THE DOZER BLADE. AVOID PIPES, ROOTS, CURBS OR OTHER HEAVY OBSTRUCTIONS.

1. Prepare the tractor engine for cold weather use following instructions furnished with tractor.
2. Always begin with transmission in first (low) gear and gradually increase speed as required.
3. If blade is stored in heated area, allow tractor and blade to adjust to outdoor temperature before operating to reduce icing on the metal surfaces.



DO NOT OPERATE TRACTOR AND DOZER BLADE AT HIGH SPEEDS WITH SPRING TRIP ACTION IN LOCKED OUT POSITION.



ALWAYS LOWER BLADE TO GROUND BEFORE LEAVING TRACTOR.

TO REMOVE DOZER BLADE FROM TRACTOR

1. Lower blade to ground with blade in the center (straight) position.
2. Refer to figure 32 below and;
 - A. Remove 1/8" hairpin cotter from the lift arm link and channel assembly.
 - B. Remove 3/32" (small) hairpin cotters and 7/16" flat washers from each lift assembly arm.
 - C. Remove 3/32" (small) hairpin cotters from right and left hand lift pivot plates, remove two 3/8" clevis pins from each side of frame, unhook and lower the lift assembly to the ground.
 - D. Remove lift rod trunnions and hex nuts from each lift link rod. See Figure 32 and figure 16 on page 7.



NOTE

Frame Brackets do not require removal for re-assembly of mower deck. See figure 32.

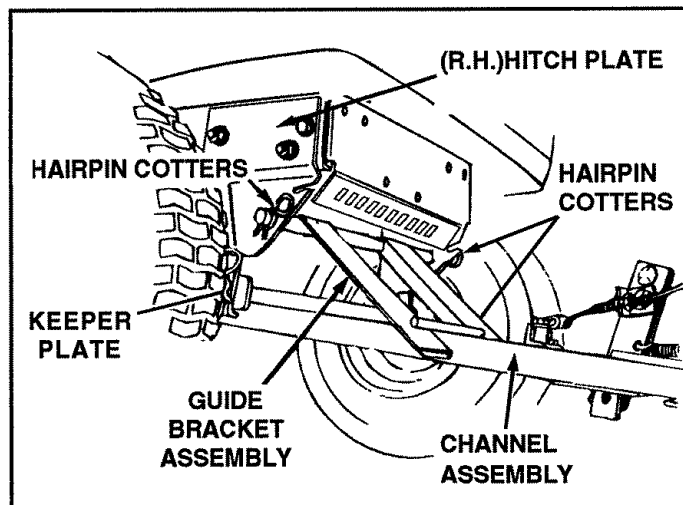

FIGURE 33

- H. Refer to figure 34 and remove hairpin cotter from end of handle guide to release handle assembly from tractor.
- I. Save all loose parts and hardware for re-assembly of blade to tractor.

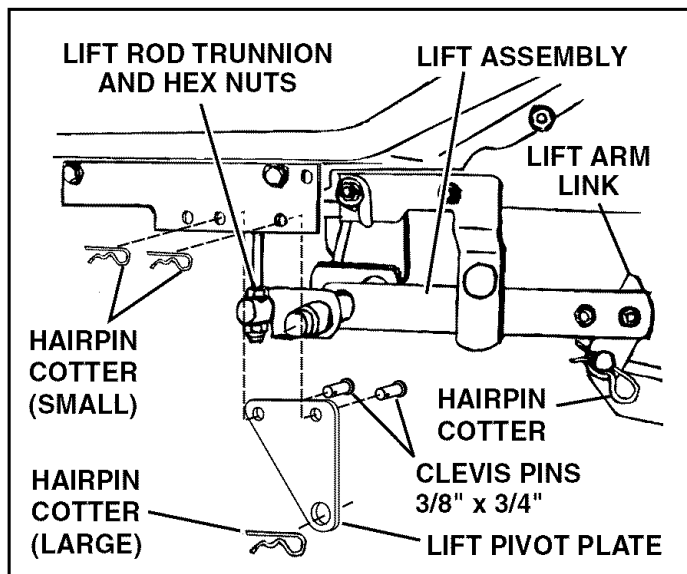

FIGURE 32

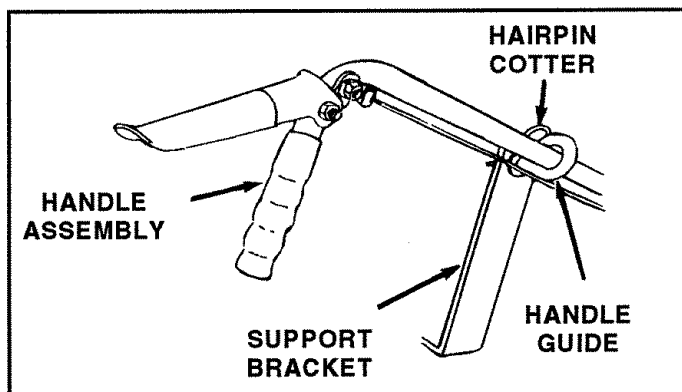

FIGURE 34

- E. Re-install suspension arms and up stop bracket removed on page 5. See figure 9 on page 5. **Refer to tractor owners manual to re-install and level mowing deck. Mowing deck must be leveled.**
- F. Refer to figure 3 and remove 1/8" (large) hairpin cotters from ends of guide bracket assembly and remove guide bracket assembly.
- G. Refer to figure 33 and remove hairpin cotters from end of channel assembly pivot shaft and remove keeper plates. Lift the channel assembly pivot shaft out of the hitch plates and lower channel assembly to the ground.

CUSTOMER RESPONSIBILITIES

During the operating season, check all bolts, nuts and hairpin cotters to be sure they are secure. For improved snow removal performance, coat the blade with automotive type paste wax.

LUBRICATION

Oil all pivot points so they will work freely.

SCRAPER BAR

After extensive use, and wear the scraper bar may be reversed to utilize the unused top edge. See figure 35.

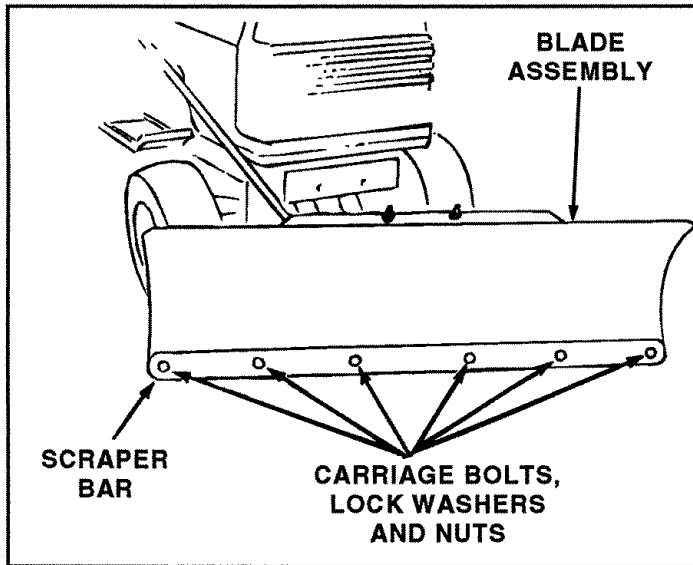

FIGURE 35

STORAGE

When the dozer is not being used, remove all dirt and rust and touch up with paint.

Apply a light coat of grease or rust preventative to the blade and oil pivot points.

Store in an area where it is protected from weather.

Attachments That Add to the Usefulness of Your Craftsman Tractor

Sears offers a wide variety of attachments for your tractor. Many of these are listed below with brief explanations of how they can help you.

Most of these attachments do not require additional hitches or conversion kits (those that do are indicated) and are designed for easy attaching and detaching. You may order these attachments at most Sears retail stores, catalog sales offices, and through the catalog.

Tire Chains are heavy duty, closely-spaced with extra-large cross links that give smooth ride and outstanding traction.

Wheel weights for rear wheels provide needed traction for snow removal or dozing heavy materials.

Weight (each)

30 lb.
33 lb.
55 lb.

Fits

Lawn Tractor with 8 in. rims
Lawn or Yard Tractors with 10 in. rims
Garden Tractor with 12 in. rims

Wheel weight mounting bracket is available to mount one 55 pound weight on the rear of your tractor frame for added traction.

REPAIR PARTS FOR MODEL 486.244122 - 48" DOZER BLADE

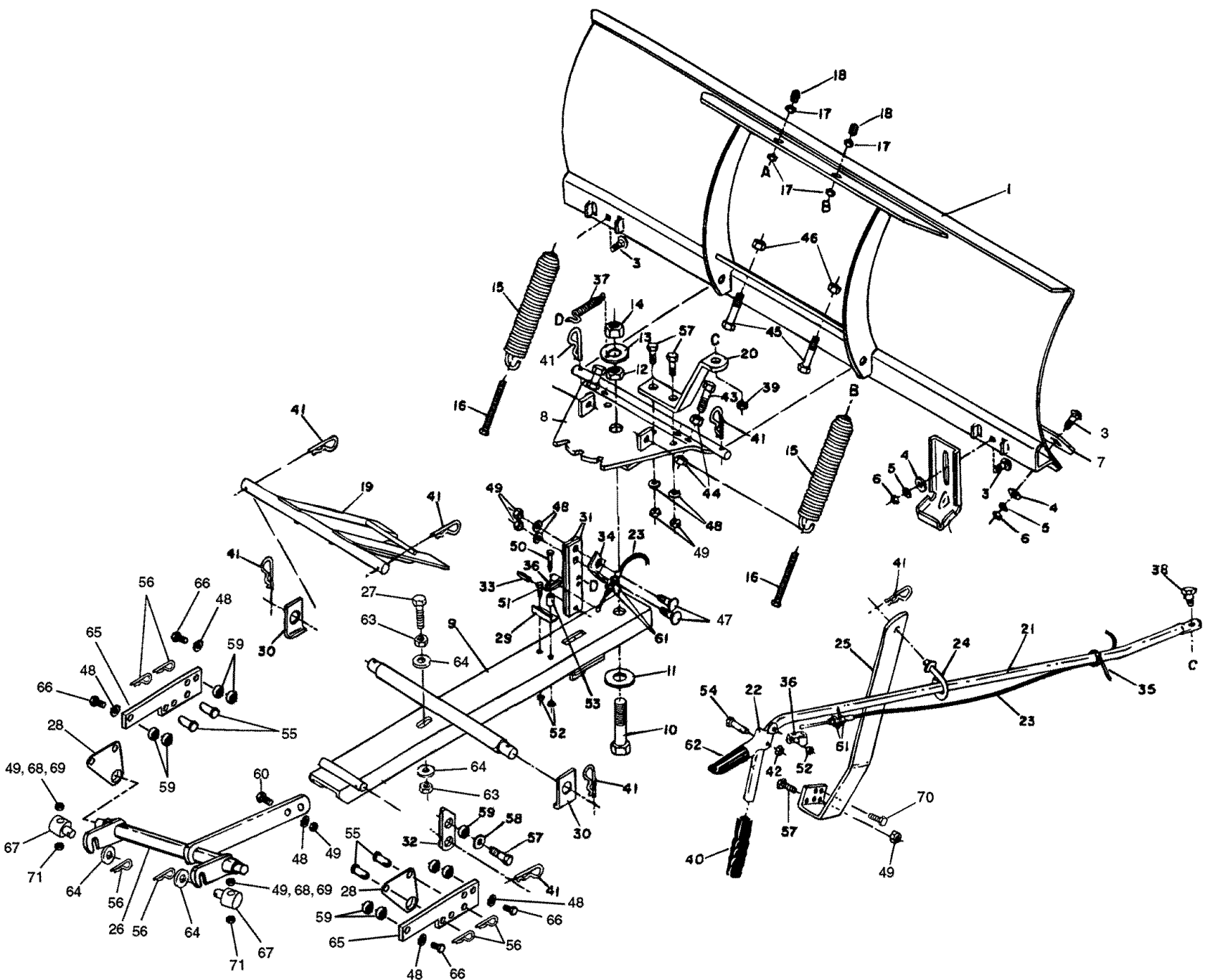

REF. NO.	PART NO.	QTY.	DESCRIPTION	REF. NO.	PART NO.	QTY.	DESCRIPTION
1	62554	1	48" Blade Ass'y.	37	43348	1	Angle Lock Spring
2	R3132J	2	Shoe	38	48106	1	Shoulder Bolt, Special 3/8-16 x 5/8"
3	44326	8	Carriage Bolt 5/16-18 x 1"	39	44072	1	Hex Whizlock Nut 3/8-16
4	43081	8	Washer 5/16 Std. Wrt.*	40	7071	1	Handle Grip 3/4"
5	43086	8	Lock Washer, Spring 5/16*	41	43343	10	Hairpin Cotter 1/8"
6	43083	8	Hex Nut 5/16-18*	42	47810	1	Nylock Nut 5/16-18*
7	23639	1	Wear Plate 48"	43	41596	2	Hex Bolt 1/2-13 x 2"
8	62556	1	Pivot Plate Ass'y.	44	712-0206	4	Hex Nut 1/2-13*
9	62944	1	Channel Ass'y.	45	43510	2	Hex Bolt 1/2-13 x 2-3/4"
10	710-0741	1	Hex Bolt 3/4-10 x 3-1/2"	46	712-0383	2	Nylock Nut, 1/2-13
11	1540-162	1	Washer 3/4"	47	710-0305	2	Carriage Bolt 3/8-16 x 1-1/4"
12	40436	1	Hex Jam Nut 3/4-10*	48	43003	4	Lock Washer, Spring 3/8"
13	736-0306	1	Washer 3/4 (Special)	49	HA21362	10	Nylock Nut 3/8-16*
14	40598	1	Hex Lock Nut 3/4-10	50	43648	1	Hex Bolt 1/4-20 x 1-1/2"
15	9466R	2	Blade Adjustment Spring	51	43012	1	Hex Bolt 1/4-20 x 3/4"
16	44071	2	Hex Bolt 3/8-16 x 3-1/2"	52	47189	3	Nylock Nut 1/4-20*
17	43015	4	Hex Nut 3/8-16*	53	23658	1	Spacer, Long
18	44074	2	Plastic Cap, 3/8"	54	43085	1	Hex Bolt 5/16-18 x 1-1/2"
19	62868	1	Guide Bracket Ass'y.	55	44044	4	Clevis Pin, 3/8" Dia. x 3/4" Lg.
20	23646	1	Blade Pivot Bracket	56	43055	6	Hairpin Cotter 3/32"
21	62560	1	Tube Handle Ass'y.	57	43087	5	Hex Bolt 3/8-16 x 1-1/4"
22	62561	1	Release Grip Ass'y.	58	43070	1	Washer 3/8 Std. Wrt.*
23	746-0366	1	Control Cable Ass'y	59	23625	9	Spacer, Short
24	62562	1	Handle Guide	60	43001	1	Hex Bolt 3/8-16 x 1"
25	23728	1	Support Bracket	61	712-0256	4	Hex Jam Nut 5/16-24*
26	62951	1	Lift Ass'y.	62	731-0869	1	Plastic Grip
27	45100	1	Hex Bolt 1/2-13 x 4"	63	43019	2	Hex Jam Nut 1/2-13*
28	23922	2	Lift Pivot Plate	64	43352	4	Washer 7/16 Std. Wrt.*
29	23655	1	Stop Angle	65	25301	2	Frame Bracket
30	23624	2	Keeper Plate	66	43768	4	Hex Bolt 3/8-16 x 1-1/2" Long*
31	23151	2	Angle Lock Bar	67	46001	2	Lift Rod Trunnion
32	23631	1	Lift Arm Link	68	44684	2	Jam Nut, 3/8-24 Fine Thread
33	43349	1	Spring Pin 1/4 x 1"	69	48183	4	Hex Jam Nut, 7/16-20 Fine Thread
34	05762	1	Cable Mount Bracket	70	HA23193	2	Hex Bolt, 3/8-16 x 1" Thread Forming
35	726-0178	1	Nylon Tie (Cable)		49344	1	Owners Manual
36	746-0260	2	Cable Fitting, End				

*Purchase common hardware locally.

Get it fixed, at your home or ours!

For repair of major brand appliances **in your own home...**
no matter who made it, no matter who sold it!

1-800-4-MY-HOMESM Anytime, day or night
(1-800-469-4663)

www.sears.com

To bring in products such as vacuums, lawn equipment and electronics
for repair, call for the location of your nearest **Sears Parts & Repair Center.**

1-800-488-1222 Anytime, day or night

www.sears.com

For the replacement parts, accessories and owner's manuals
that you need to do-it-yourself, call **Sears PartsDirectSM**!

1-800-366-PART 6 a.m. – 11 p.m. CST,
(1-800-366-7278) 7 days a week

www.sears.com/partsdirect

To purchase or inquire about a Sears Service Agreement:

1-800-827-6655

7 a.m. – 5 p.m. CST, Mon. – Sat.

Para pedir servicio de reparación a domicilio,
y para ordenar piezas con entrega a domicilio:

1-888-SU-HOGARSM
(1-888-784-6427)

Au Canada pour service en français:

1-877-LE-FOYERSM
(1-877-533-6937)

