

Agri-Fab®

OWNERS MANUAL

Model No.
45-0354

CAUTION:
Read Rules for
Safe Operation
and Instructions
Carefully

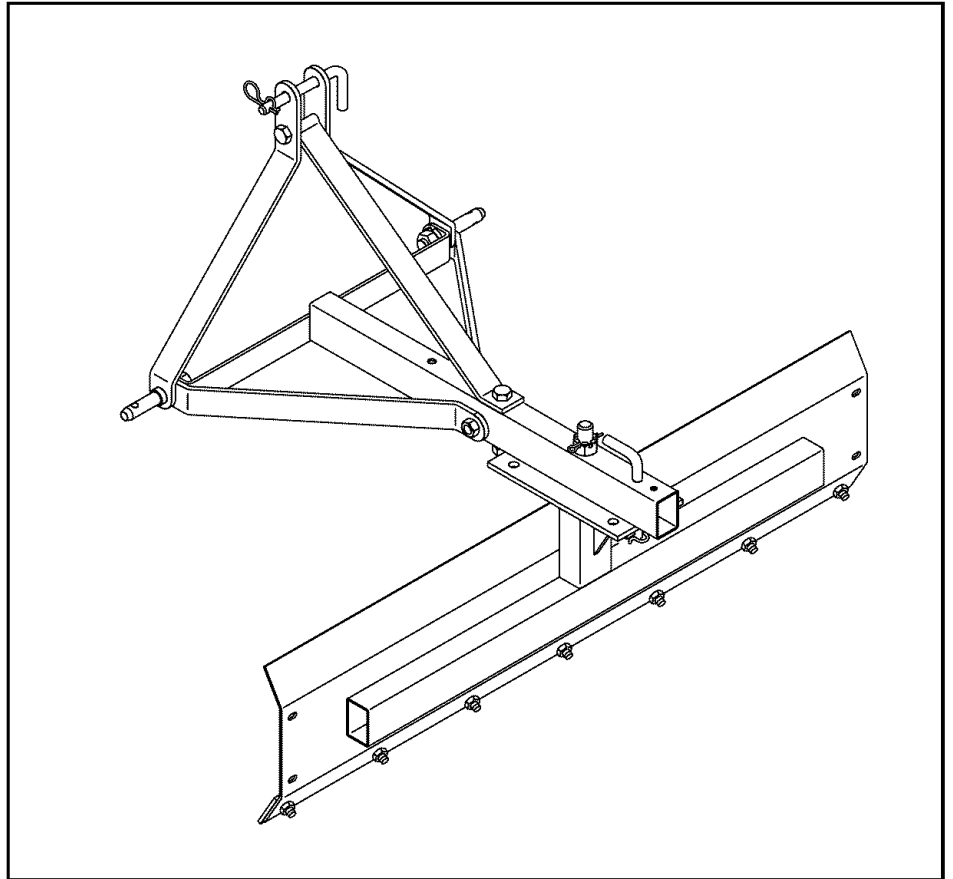

GRADER BLADE

- Safety
- Assembly
- Operation
- Maintenance
- Parts

SpeedEPart *the fastest way to purchase parts* www.speedepart.com

SAFETY RULES

Remember, any power equipment can cause injury if operated improperly or if the user does not understand how to operate the equipment. Exercise caution at all times when using power equipment.



LOOK FOR THIS SYMBOL TO POINT OUT IMPORTANT SAFETY PRECAUTIONS. IT MEANS – ATTENTION! BECOME ALERT! YOUR SAFETY IS INVOLVED.



CAUTION: VEHICLE BRAKING AND STABILITY MAY BE AFFECTED BY THE ADDITION OF AN ACCESSORY OR AN ATTACHMENT. BE AWARE OF CHANGING CONDITIONS ON SLOPES.

1. Read this owner's manual before using this equipment.
2. Do not allow children to operate the tow vehicle or the grader blade.
3. Do not allow adults to operate the tow vehicle or the grader blade without proper instruction.
4. Do not allow anyone to ride on the tow vehicle or the grader blade.
5. Before lowering the grader blade, make sure no one is near the area of operation.
6. Lower the grader blade when leaving the tow vehicle unattended.
7. Wear appropriate footwear when using the grader blade.
8. Tow vehicle braking and stability may be affected by the grader blade. Drive slowly with the grader blade in the transport position. **Stay off steep slopes.**
9. Stop and inspect the equipment for damage after striking an object. Repair any damage before continuing operation.
10. Keep all nuts and bolts tight and be sure that the equipment is in safe operating condition.
11. Before attaching or removing the grader blade, park and lock the tow vehicle in a safe condition.

CARTON CONTENTS

- | | |
|-------------------|------------------------------|
| 1. Mast Side (2) | 4. Blade Scraper |
| 2. Blade Assembly | 5. Mast Support |
| 3. Mast Assembly | 6. Mast Brace (2) |
| | 7. Parts Package (not shown) |

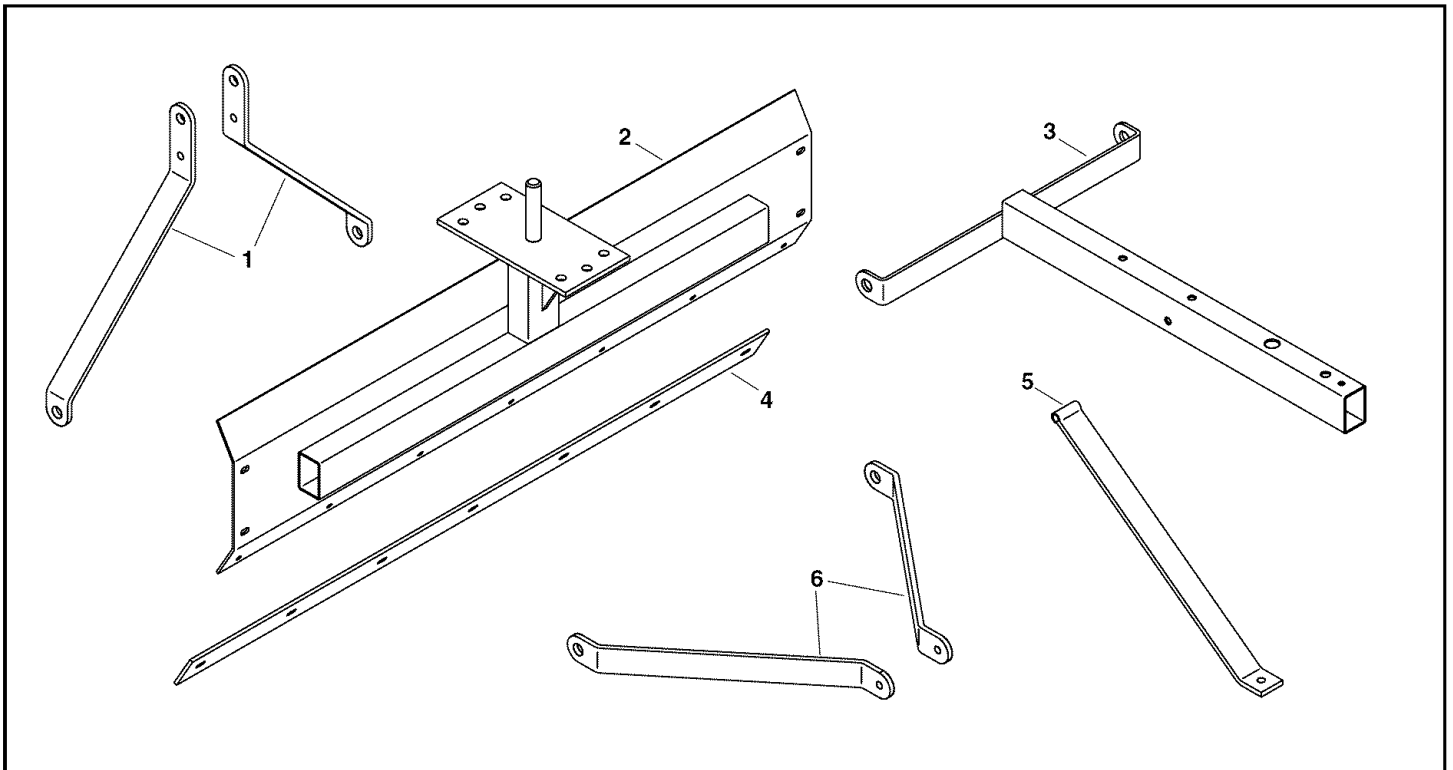

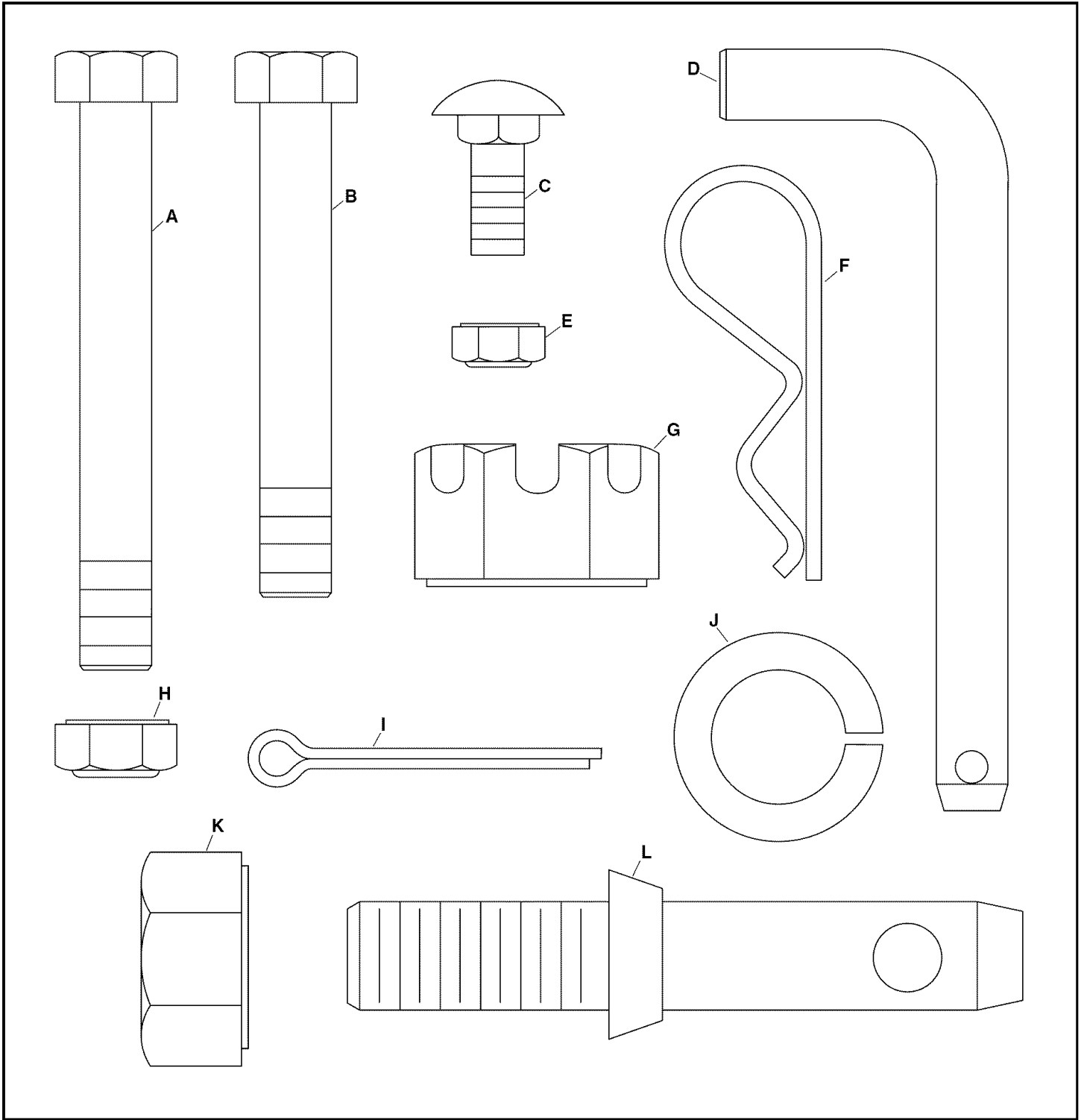

PARTS PACKAGE CONTENTS – PARTS SHOWN ACTUAL SIZE

KEY	QTY.	DESCRIPTION	KEY	QTY.	DESCRIPTION
A	1	Hex Bolt, 1/2" x 4" Lg.	G	1	Hex Nut, Slotted, 1"
B	2	Hex Bolt, 1/2" x 3-1/2" Lg.	H	3	Hex Nut, Nylock, 1/2"
C	7	Carriage Bolt, 3/8" x 1" Lg.	I	1	Cotter Pin
D	2	Pivot Pin	J	2	Lock Washer, 7/8"
E	7	Hex Nut, Nylock, 3/8"	K	2	Hex Nut, 7/8"
F	2	Haircotter Pin	L	2	Category 1 Pin

ASSEMBLY

TOOLS REQUIRED FOR ASSEMBLY

- (2) 3/4" Wrenches
- (1) 9/16" Wrench
- (1) 1-5/16" Wrench or 12" Adjustable Wrench
- (1) 1-1/2" Wrench or 14" Adjustable Wrench
- (1) Pliers



CAUTION: THE BLADE SCRAPER AND BLADE ASSEMBLY HAVE SHARP EDGES. USE CARE IN HANDLING AND ASSEMBLY. WEAR GLOVES FOR EXTRA PROTECTION AGAINST CUTS.

Remove all loose parts and the hardware package from the shipping carton. Then lay out and identify each part and the common hardware as shown on pages 2 and 3. Be sure the carton is empty before it is discarded.

1. Assemble the blade scraper to the blade assembly using seven 3/8" x 1" carriage bolts and seven 3/8" Nylock hex nuts. **Tighten.** See figure 1.

When installing the scraper to the blade assembly, be sure the scraper is on the curved (dished) side of the blade assembly and that the carriage bolts are installed with the hex nuts on the back of the blade assembly. Make sure all hex nuts are tight.

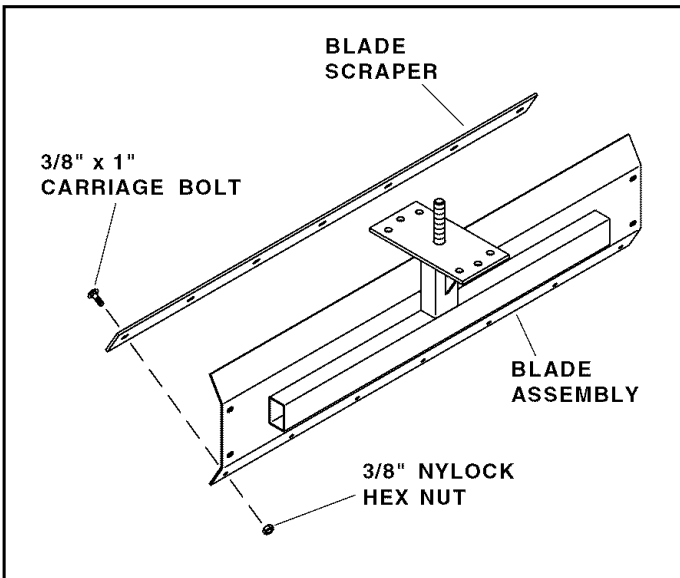

FIGURE 1

2. Turn the mast assembly so that the cross brace is at the bottom and the hole in the side of the mast assembly is close to the bottom. Place the mast assembly onto the threaded stud on the blade assembly. Turn a 1" slotted hex nut down onto the stud until it is snug. The cross brace should be in front of the blade. See figure 2.

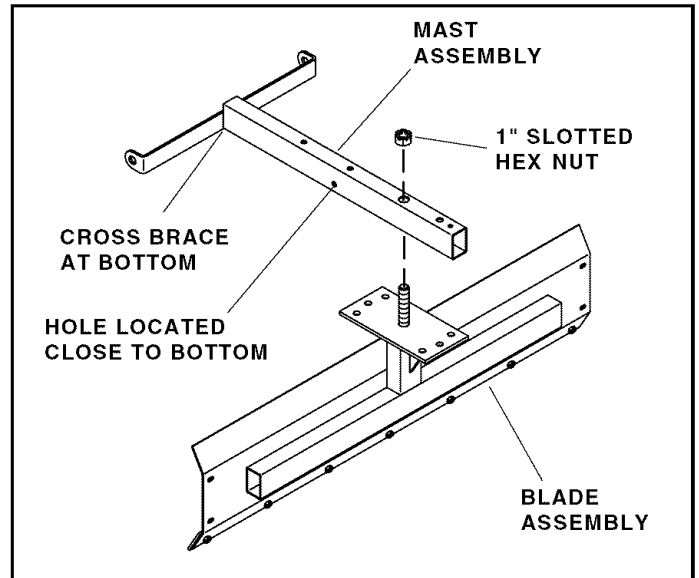

FIGURE 2

3. Back the slotted nut off until the first slot is aligned with the hole in the threaded stud or until the mast assembly can pivot on the blade assembly. Install a cotter pin through the hole in the stud. Then bend both ends of the cotter pin around the crown of the nut to secure the pin and nut. See figure 3.

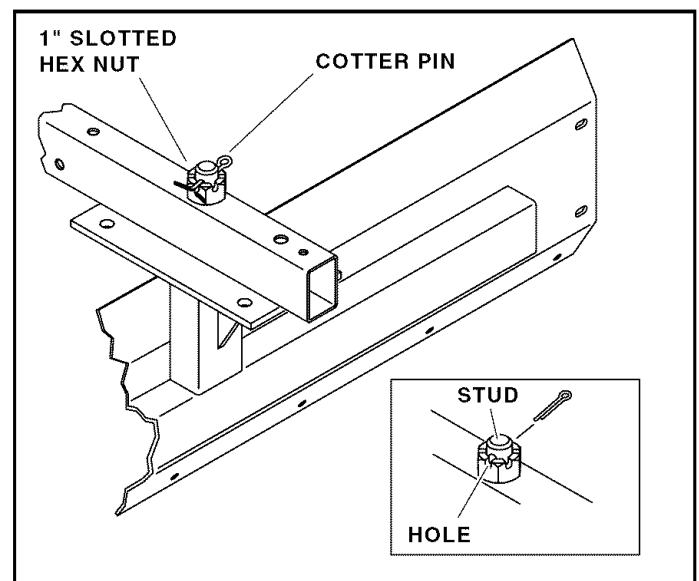

FIGURE 3

- Attach the mast support to the hole in the mast assembly just in front of the threaded stud. Use a 1/2" x 4" hex bolt and 1/2" Nylock hex nut installed so that the nut is on the bottom side of the mast assembly. **Do not tighten yet.** See figure 4.

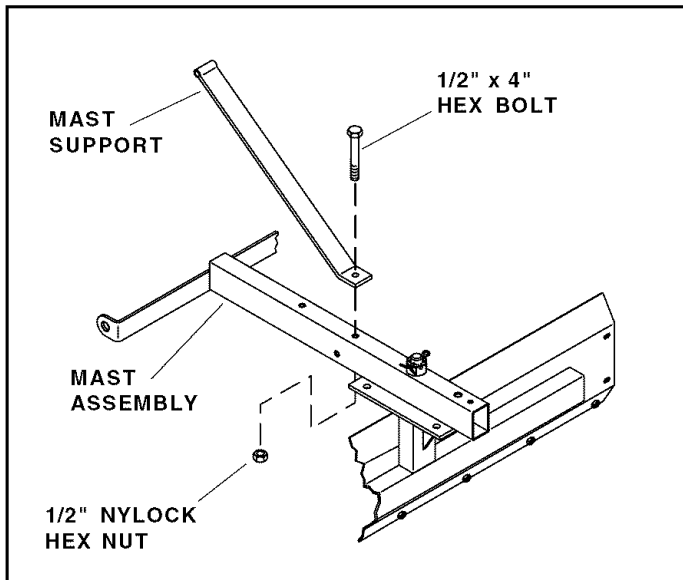

FIGURE 4

- Attach two mast braces to the sides of the mast assembly using a 1/2" x 3-1/2" hex bolt and 1/2" Nylock hex nut. Use the end of each brace with the smallest hole. **Do not tighten yet.** See figure 5.

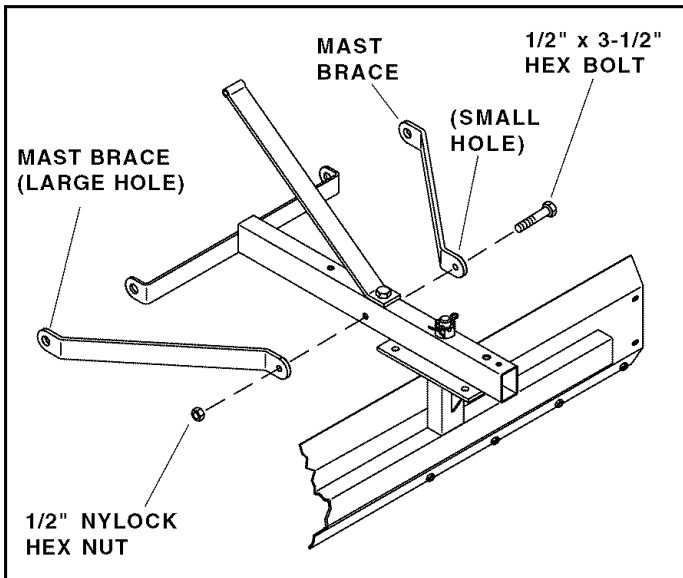

FIGURE 5

- Attach two mast sides to the mast support using a 1/2" x 3-1/2" hex bolt and 1/2" Nylock hex nut. Use the end of the mast side with two holes, inserting the hex bolt through the smaller hole. **Do not tighten yet.** See figure 6.

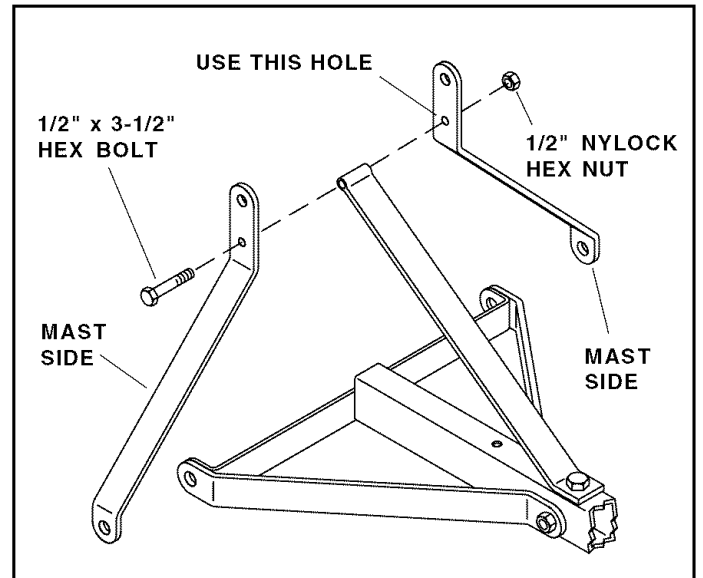

FIGURE 6

- Connect the lower end of each mast side and the front end of the each mast brace to the ends of the mast assembly's cross brace using two category 1 pins, two 7/8" lock washers, and two 7/8" hex nuts. See figure 7.

Be sure the threaded end of each category 1 pin is toward the center of the grader frame so that the threaded ends face each other. **Securely tighten** the hex nuts against the lock washers. **Tighten all** previously installed mast hardware.

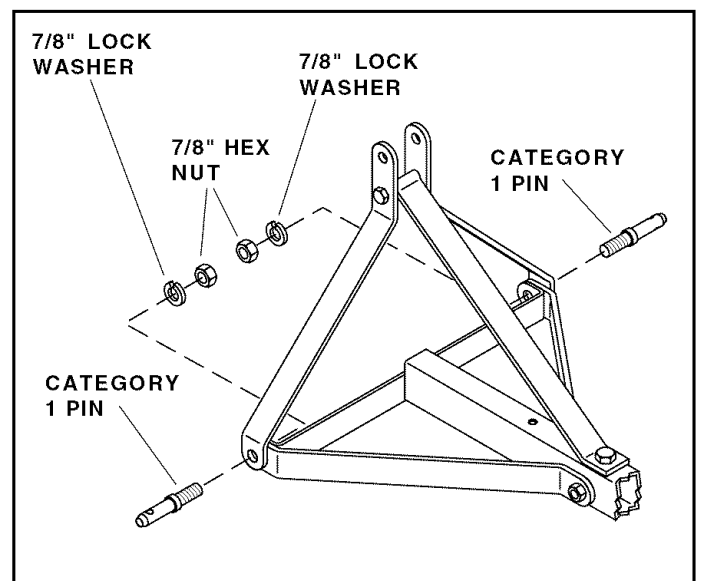

FIGURE 7

- Lock the blade assembly to the mast assembly by installing a pivot pin at the rear of the mast assembly. Secure the pin using a haircotter pin through the hole in the end of the pivot pin. See figure 8.
- Install a pivot pin through the hole at the upper end of the mast sides to provide a connection point for the tow vehicle's winch system. Secure the pin with a haircotter pin through the hole in the end of the pivot pin. See figure 8.

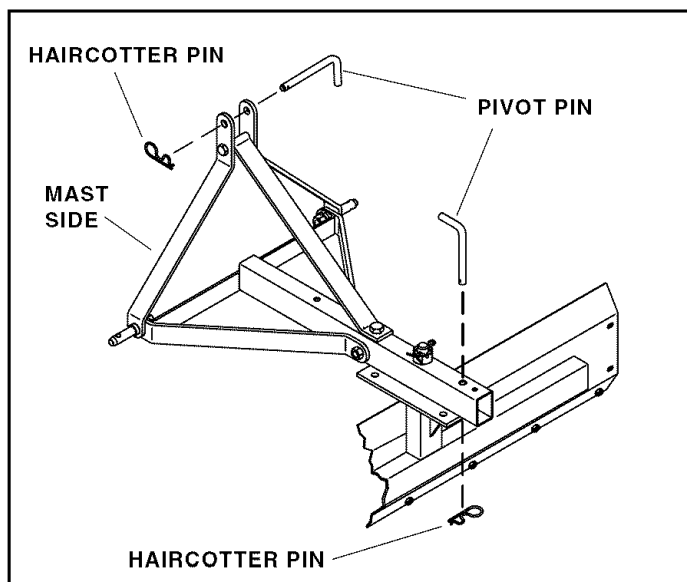

FIGURE 8

OPERATION



CAUTION: USE CARE WHEN WORKING AROUND A RAISED GRADER BLADE. KEEP YOUR FEET AND HANDS FROM UNDER THE SCRAPER BLADE AT ALL TIMES. SERIOUS INJURY CAN RESULT SHOULD THE GRADER BLADE DROP UNEXPECTEDLY.

The grader blade is used to level and smooth road or other landscape surfaces.

- Before starting, if you are going to be grading dirt, make sure it is dry enough by squeezing some in your hand. If it forms a ball that doesn't crumble, the dirt may be too wet for grading.

- The blade can be set to push or pull dirt, with three grading angle settings in both the forward and reverse positions. Do not use the reverse position if the blade is attached to a 3-point hitch trailer. The trailer is designed for towing only.
- To rotate the blade to the desired setting, first raise the grader blade so that the scraper blade is just off the ground. Remove the pivot pin from the mast assembly and rotate the blade. Align the hole in the mast with a hole in the pivot plate and install the pivot pin, securing it with the haircotter pin. See figure 9.
- To prevent the blade from digging deeper at one end, be sure the blade is level from side to side and the mast assembly is level from front to back. Front to back leveling prevents the blade from digging deeper at one end when the blade is rotated to an angled setting. Refer to your 3-point hitch manual for instructions on leveling the grader blade attachment.

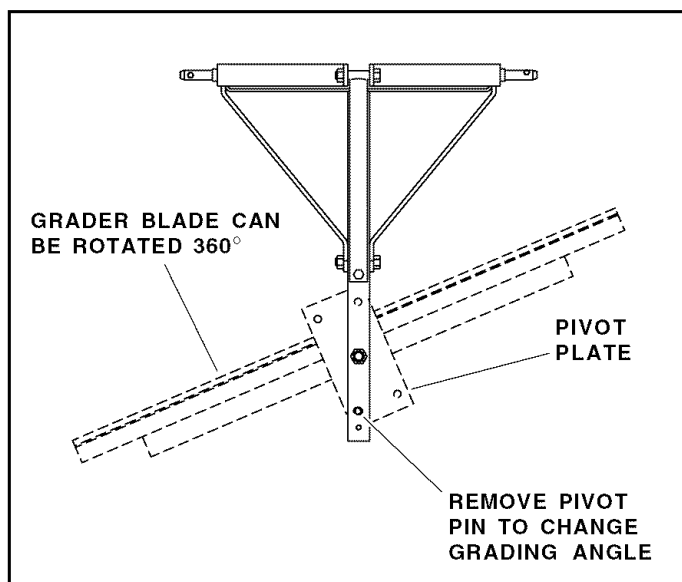
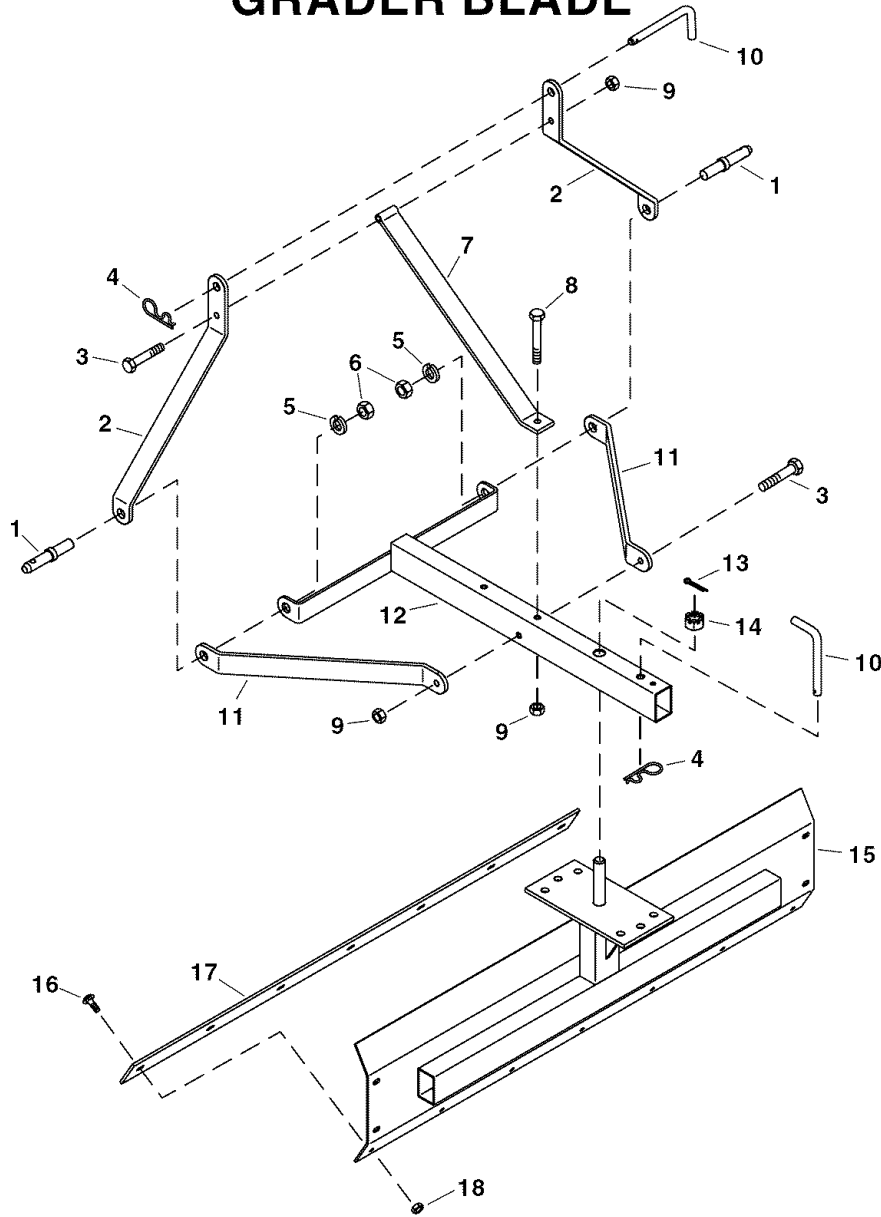

FIGURE 9

MAINTENANCE

- Check for and tighten any loose hardware before each use.
- Check scraper blade for wear. The blade can be turned top for bottom for additional life.
- Clean the scraper blade and lightly oil any bare metal after each use.
- Remove all dirt and rust. Touch up paint before placing grader blade in storage.
- Store grader blade inside a dry area.

REPAIR PARTS FOR MODEL NO. 45-0354 GRADER BLADE



REF. NO.	PART NO.	QTY.	DESCRIPTION	REF. NO.	PART NO.	QTY.	DESCRIPTION
1	48979	2	Category 1 Pin	11	25157	2	Mast Brace
2	25158	2	Mast Side	12	64779	1	Mast Assembly
3	46526	2	Hex Bolt, 1/2" x 3-1/2" Lg.	13	46855	1	Cotter Pin, 3/16" x 2"
4	43343	2	Haircotter Pin, 1/8" x 2-3/8"	14	48968	1	Hex Nut, Slotted, 1"
5	48982	2	Lock Washer, 7/8"	15	64766	1	Blade Assembly
6	48970	2	Hex Nut, 7/8"	16	43350	7	Carriage Bolt, 3/8" x 1" Lg.
7	64793	1	Mast Support	17	25149	1	Blade Scraper
8	45100	1	Hex Bolt, 1/2" x 4" Lg.	18	HA21362	7	Hex Nut, Nylock, 3/8"
9	712-3083	3	Hex Nut, Nylock, 1/2"	19	48976	1	Owners Manual (not shown)
10	48978	2	Pivot Pin, 3-3/4" Lg.				

SpeedEPart *the fastest way to purchase parts* www.speedepart.com

REPAIR PARTS
Agri-Fab, Inc.
303 West Raymond
Sullivan, IL. 61951
217-728-8388
www.agri-fab.com