

Agri-Fab®

OWNER'S MANUAL

Model No.

45-0353

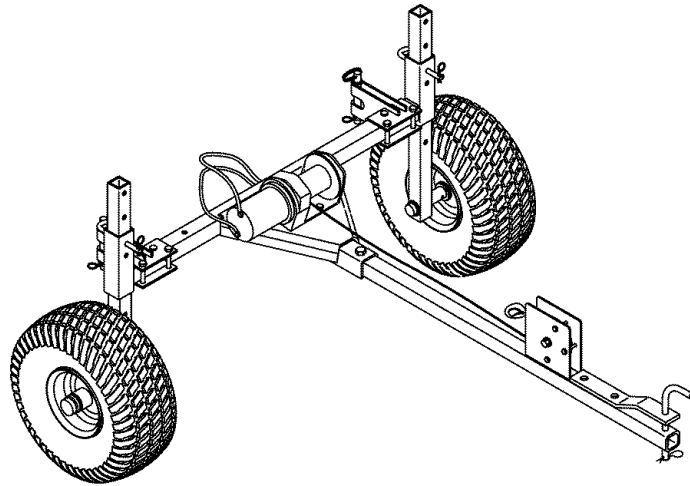

3-POINT HITCH TRAILER

CAUTION:
Read Rules for
Safe Operation
and Instructions
Carefully

- Safety
- Assembly
- Operation
- Maintenance
- Parts

SpeedPart *the fastest way to purchase parts* www.speedepart.com

SAFETY RULES

Remember, any power equipment can cause injury if operated improperly or if the user does not understand how to operate the equipment. Exercise caution at all times when using power equipment.



LOOK FOR THIS SYMBOL TO POINT OUT IMPORTANT SAFETY PRECAUTIONS. IT MEANS – ATTENTION! BECOME ALERT! YOUR SAFETY IS INVOLVED.



CAUTION: VEHICLE BRAKING AND STABILITY MAY BE AFFECTED BY THE ADDITION OF AN ACCESSORY OR AN ATTACHMENT. BE AWARE OF CHANGING CONDITIONS ON SLOPES.

1. Read this owner's manual and your vehicle's owner's manual before using this equipment.
2. Do not allow children to operate the vehicle, the hitch trailer, or any implement attached to the hitch trailer.
3. Do not allow adults to operate the vehicle, the hitch trailer, or implement without proper instruction.
4. Do not allow anyone to ride on the hitch trailer or attached implement.
5. Before lowering any implement attached to the hitch trailer, make sure no one is near the area of operation.
6. Lower any implement attached to the hitch trailer when leaving the vehicle unattended.
7. Wear appropriate footwear when using the hitch trailer. Implement attachments have sharp edges!
8. Vehicle braking and stability may be affected by the hitch trailer and attached implement. Drive slowly when hitch trailer and attached implement is in the transport position. **Stay off steep slopes.**
9. Stop and inspect the equipment for damage after striking an object. Repair any damage before continuing operation.
10. Keep all nuts and bolts tight and be sure that the equipment is in safe operating condition.
11. Before attaching or removing the hitch trailer or associated implement, park and lock tow vehicle in a safe condition.
12. This hitch trailer is rated for category 0 and 1 implements.
13. Do not exceed 400 pounds of attachment weight.

CARTON CONTENTS

- | | |
|---------------------------|------------------------------|
| 1. Axle Assembly (2) | 5. Winch |
| 2. Trailer Frame Assembly | 6. Hitch Anchor Assembly (2) |
| 3. Switch | 7. Drawbar Assembly |
| 4. Wire Harness Assembly | 8. Wheel (2) |
| | Parts Package (see page 3) |

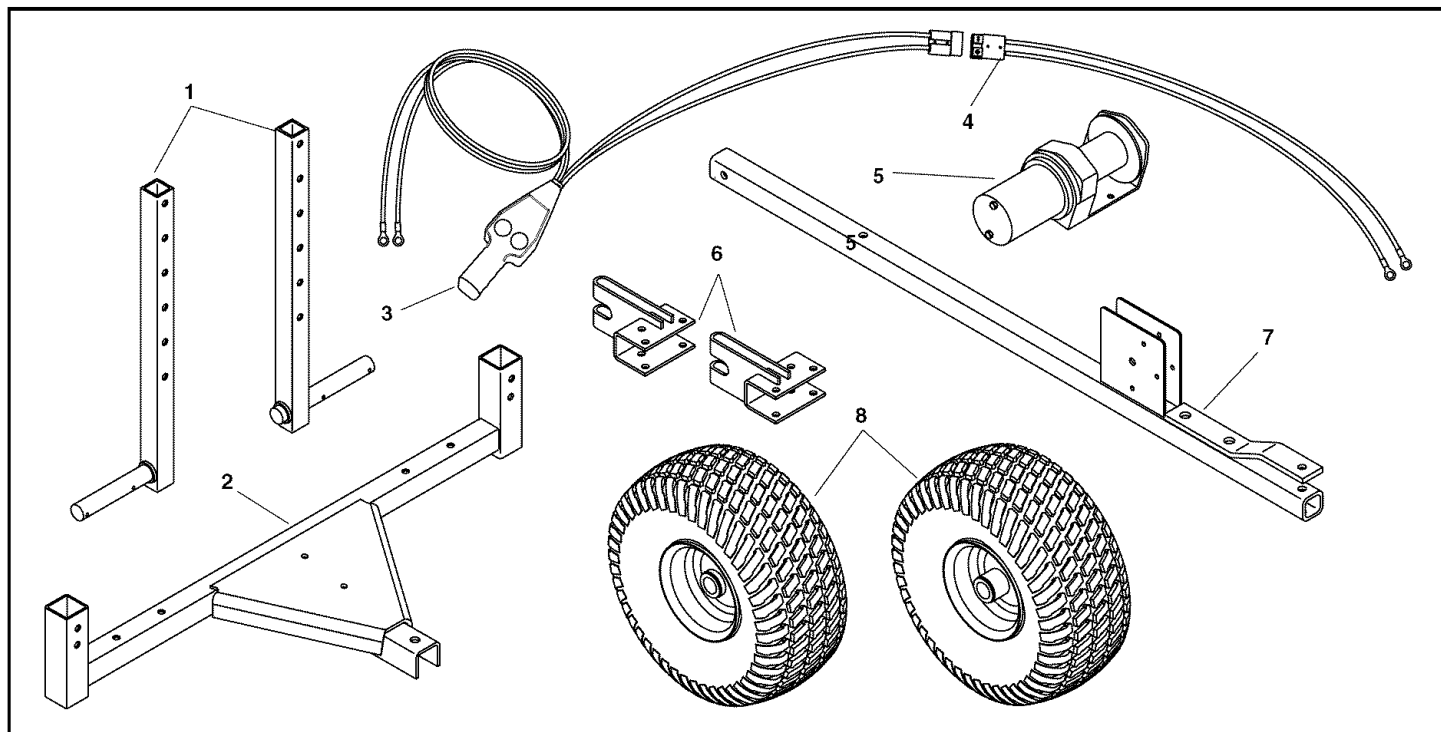

SHOWN FULL SIZE

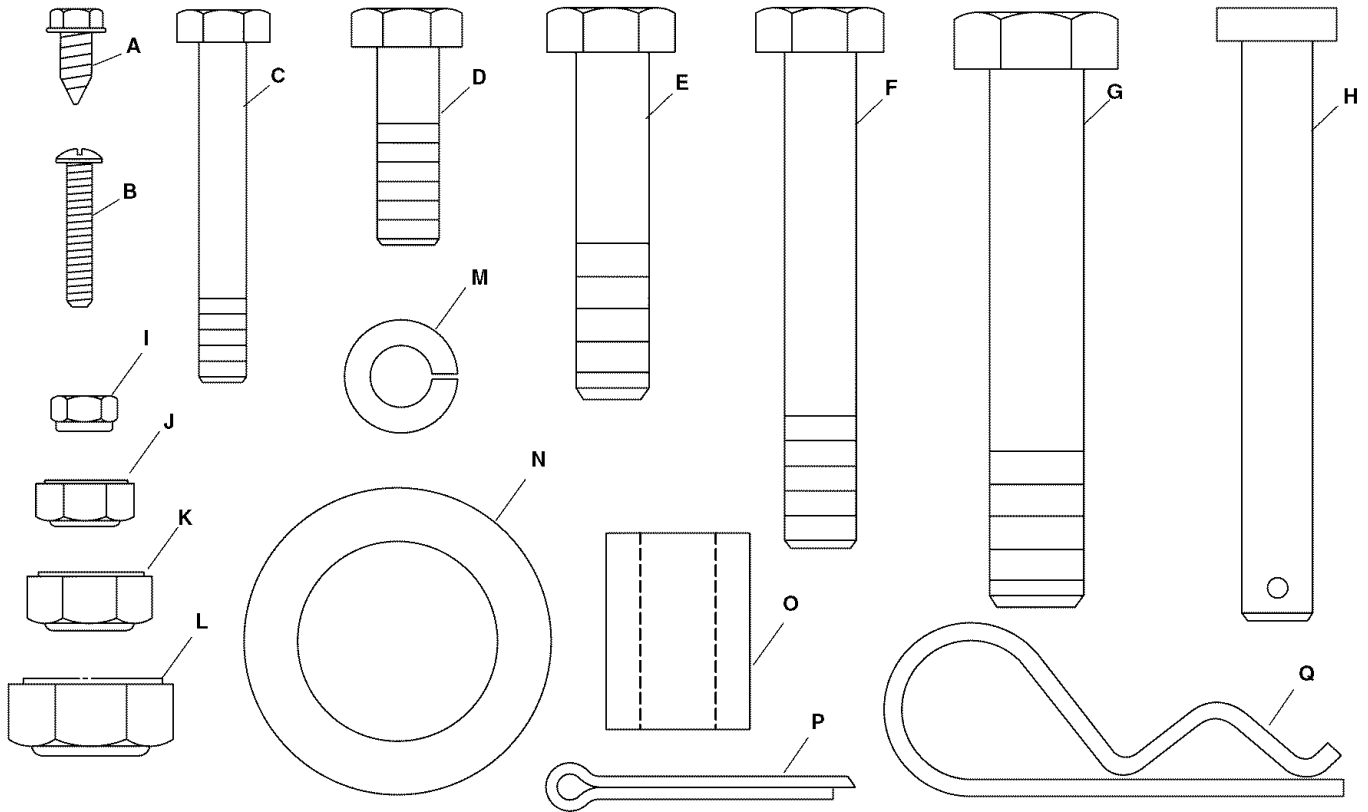

NOT SHOWN FULL SIZE

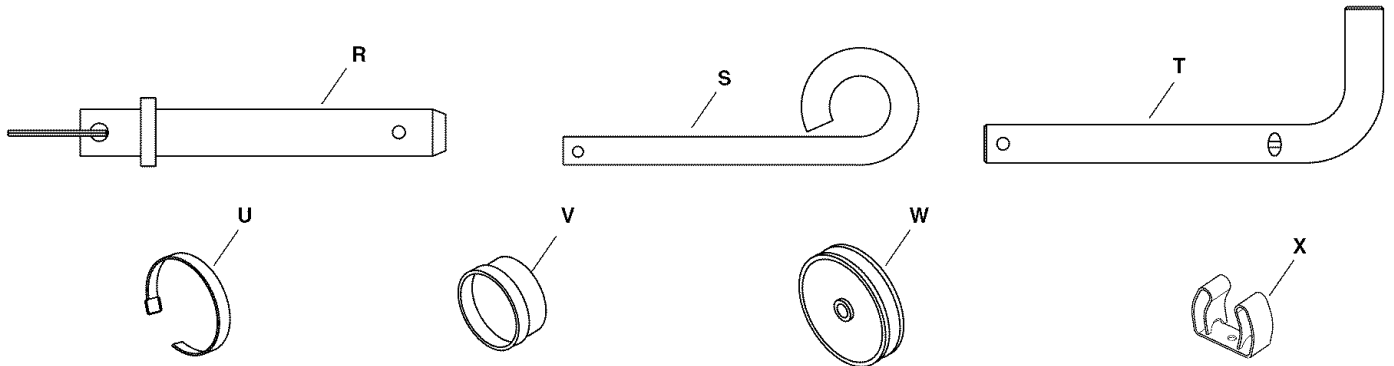

PARTS PACKAGE CONTENTS – PARTS SHOWN ACTUAL SIZE

KEY	QTY.	DESCRIPTION	KEY	QTY.	DESCRIPTION
A	1	Screw, #8 x 3/8"	M	2	Lock Washer, 5/16"
B	1	Screw, #6 x 3/4"	N	4	Washer, 1" Flat
C	2	Hex Bolt, 5/16" x 1" Lg.	O	1	Spacer
D	3	Hex Bolt, 1/4" x 1-3/4" Lg.	P	4	Cotter Pin
E	1	Hex Bolt, 3/8" x 1-3/4" Lg.	Q	7	Haircotter Pin
F	4	Hex Bolt, 3/8" x 2-1/2" Lg.	R	2	Quick Attach Pin
G	2	Hex Bolt, 1/2" x 2-3/4" Lg.	S	2	Height Adjust Pin
H	2	Clevis Pin	T	1	Hitch Pin
I	1	Hex Nut, Nylock #6	U	3	Reclosable Strap
J	3	Hex Nut, Nylock, 1/4"	V	2	Hub Cap
K	5	Hex Nut, Nylock, 3/8"	W	1	Pulley
L	2	Hex Nut, Nylock, 1/2"	X	2	Clip

ASSEMBLY

TOOLS REQUIRED FOR ASSEMBLY

- (2) 7/16" Wrenches
- (1) 1/2" Wrenches
- (2) 9/16" Wrenches
- (2) 3/4" Wrenches or 10" Adjustable Wrenches
- (1) Pliers
- (1) Grease Gun

Remove all loose parts and the hardware package from the shipping carton. Lay out and identify each part and the common hardware as shown on pages 2 and 3. Be sure the carton is empty before discarding.

1. Insert the long wires from the switch through the hole under the hitch bracket in the side of the drawbar. Route the wires out through the rear end of the drawbar. See figure 1.
2. Attach the drawbar assembly to the trailer frame assembly using two 1/2" x 2-3/4" hex bolts and 1/2" Nylock hex nuts. See figure 1.

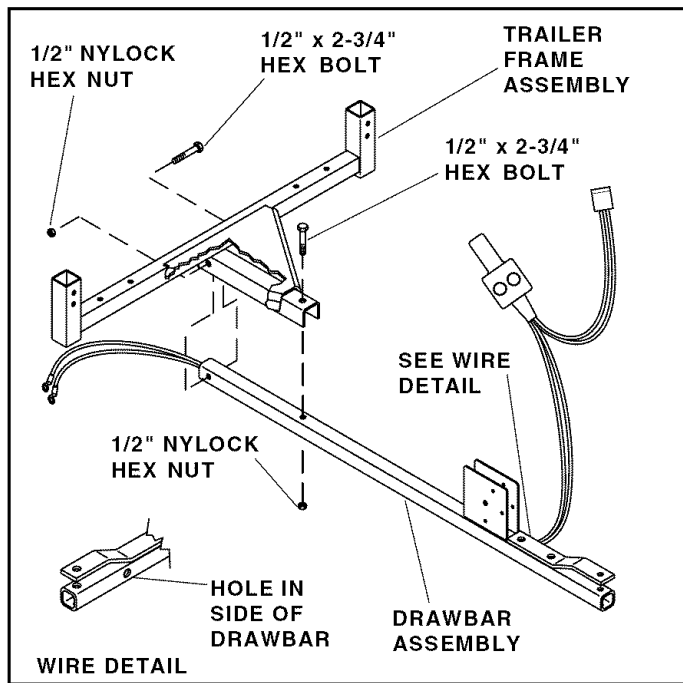

FIGURE 1

3. Slide an axle assembly up through one end of the trailer frame, with the shaft of the axle pointing **out**. Pin the axle to the frame using a height adjust pin and a haircotter pin. Repeat this step for the other axle assembly on the opposite end of the trailer. Be sure both axles are pinned at the same height. See figure 2.

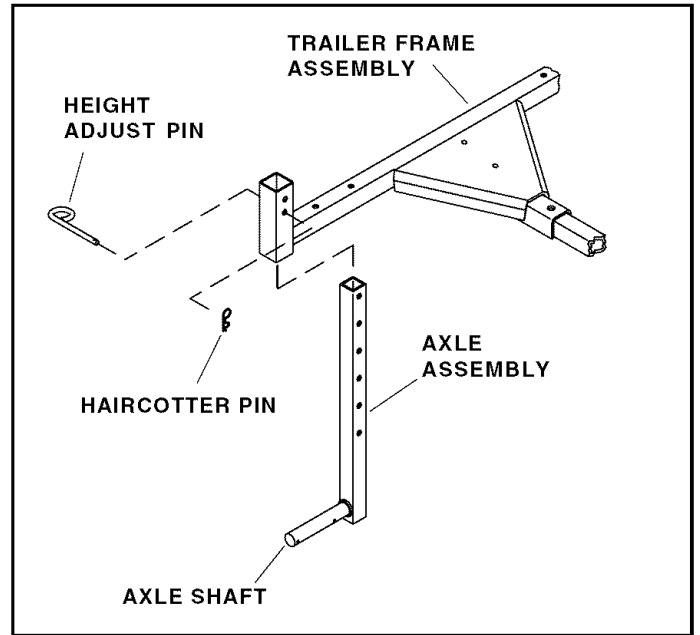

FIGURE 2

4. Install the wheels (see figure 3):
 - Install a cotter pin in the inner hole of the axle shaft.
 - Install a wheel on the axle shaft with a 1" flat washer on each side of the wheel. Be sure the air stem is toward the outside for easy access.
 - Install another cotter pin in outer hole of axle.
 - Install a hub cap, snapping it onto the washer.
 - Fill the wheel hubs with grease using a grease gun.
 - Repeat this step for the opposite axle.

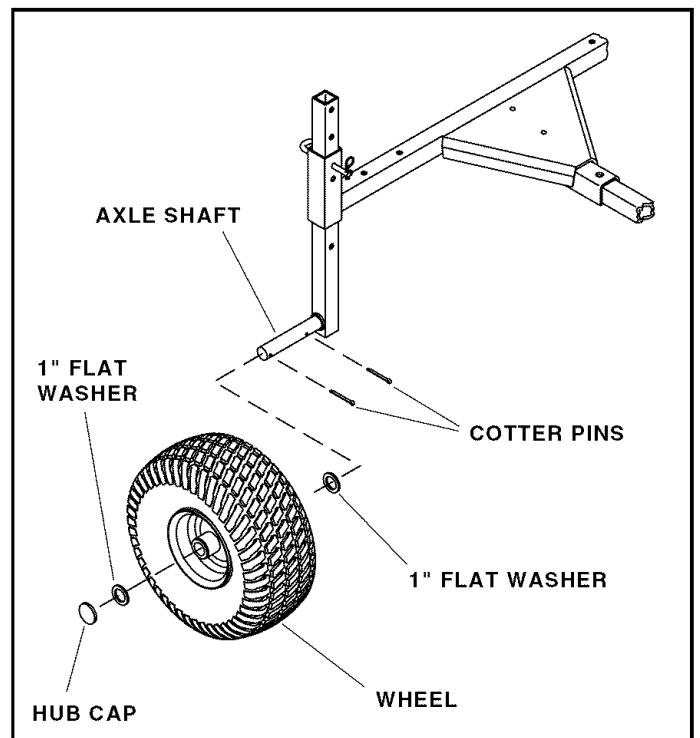

FIGURE 3

5. Install the hitch anchors onto the ends of the trailer frame. The clevis pin hole should be to the inside. Secure with four 3/8" x 2-1/2" hex bolts and 3/8" Nylock hex nuts. Tighten the nuts only until they are just snug. Slide each hitch anchor along the frame to align with the outer hole for category 1 implements or the inner hole are for category 0 implements. Secure each hitch anchor with a clevis pin and haircotter pin. See figure 4.

6. Install a quick attach pin in the slot of each hitch anchor. Secure with a haircotter pin. See figure 4.

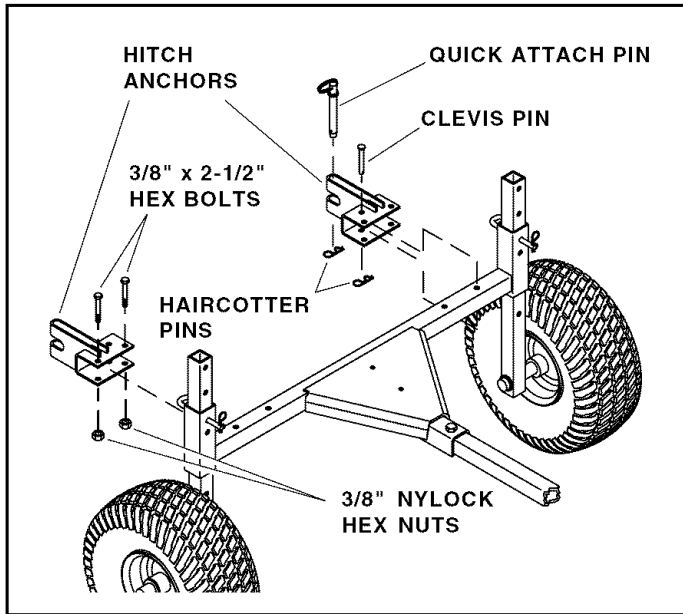

FIGURE 4

7. Position the winch on the hitch trailer so that the tension plate is on the back of the winch and the wire rope feeds out from the bottom of the drum at the front. Secure the winch to the trailer using two 5/16" x 1" hex bolts and 5/16" lock washers. See figure 5.

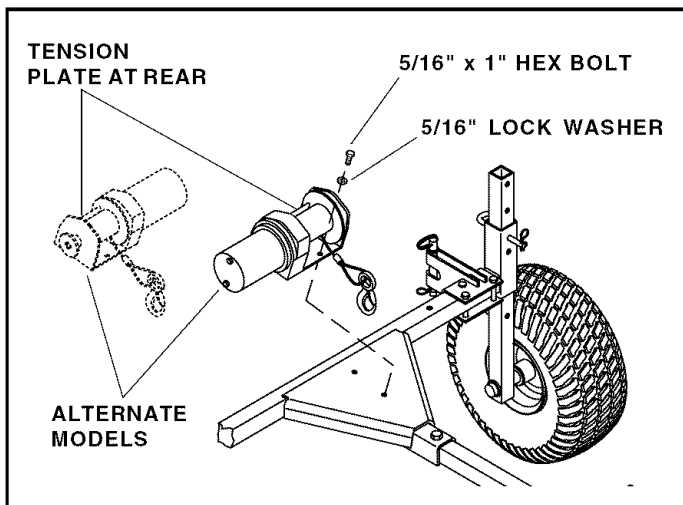
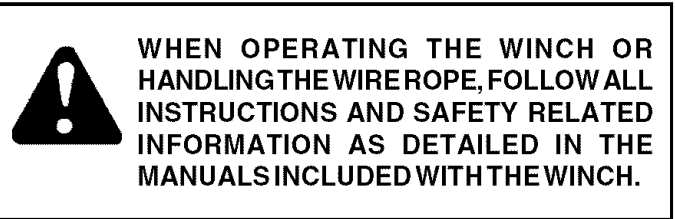

FIGURE 5



8. Install three 1/4" x 1-3/4" hex bolts and 1/4" Nylock hex nuts through the pulley bracket welded to the drawbar. Tighten the nuts, but leave them loose enough that the bolts can still spin. See figure 6.

9. Set the winch drum to "freewheel" according to the instructions in the winch manual. Pull enough wire rope from the drum to extend the hooked end of the rope past the hitch end of the drawbar. See figure 6.

10. Install a 1" spacer in the hub of the pulley. Loop the wire rope under and around the pulley and then install the pulley in the bracket using a 3/8" x 1-3/4" hex bolt and a 3/8" Nylock hex nut. **Tighten.** See figure 6.

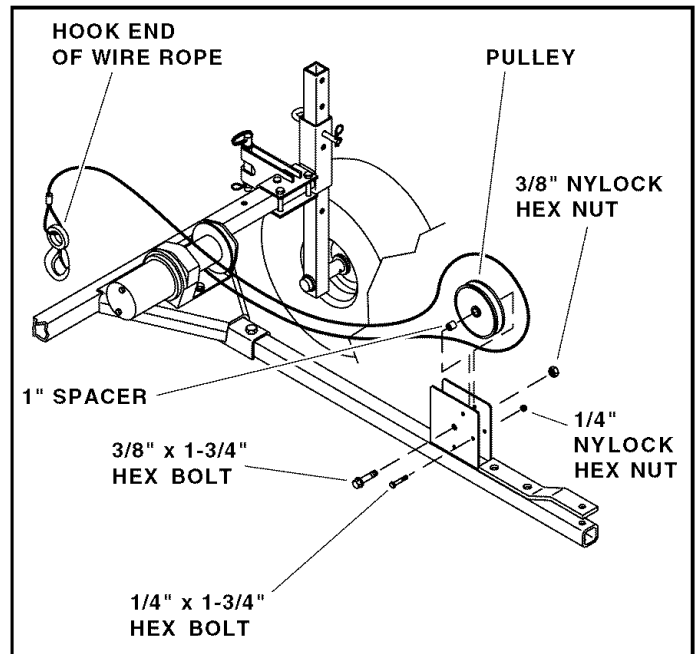

FIGURE 6

ELECTRICAL CONNECTIONS



REFER TO THE INSTRUCTION MANUAL FOR THE WINCH BEFORE MAKING ELECTRICAL CONNECTIONS.

1. Connect the wires in the drawbar to the winch terminals, securing red to positive and black to negative. See figure 7.

NOTE: If the winch terminals are not marked positive and negative, you will need to check the direction of rotation after you complete the wiring hookup. Reverse the winch hookup if the cable winds in when it should wind out.

2. Connect the trailer to the vehicle hitch using the trailer hitch pin and a hair cotter pin.
3. Connect the wire harness to the vehicle battery. Secure the red wire to the positive terminal and the black wire to the negative terminal. See figure 7.

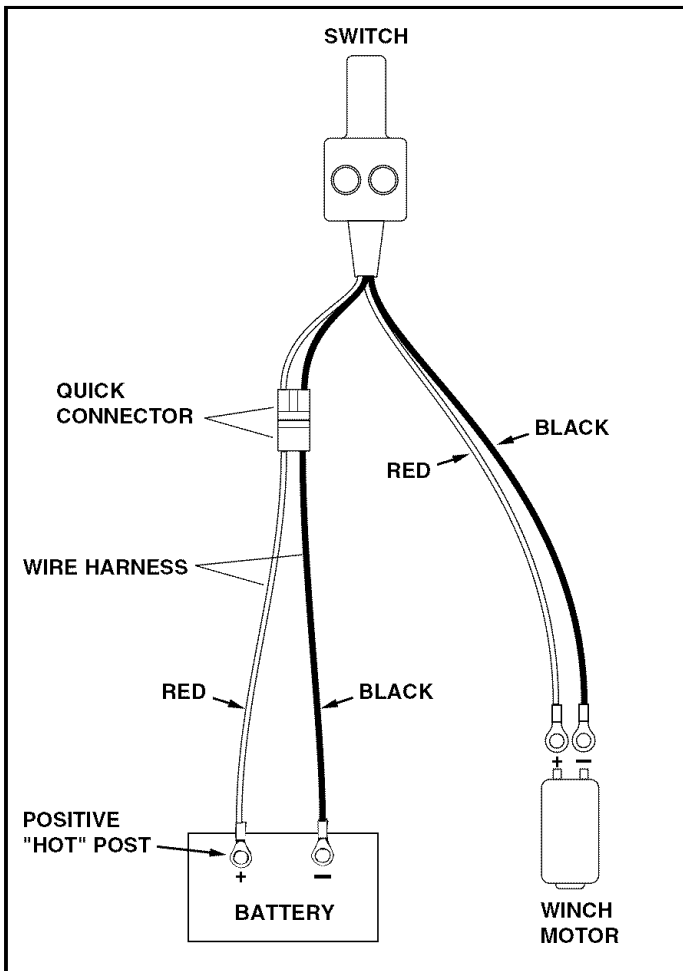

FIGURE 7

4. Route the wire harness from the battery to the rear of the vehicle. Be sure the wires are clear of any moving parts, hot engine parts, or pinch points. Attach a clip to the quick connector on the wire harness using a #6 x 3/4" screw and a nylock nut. Clip the quick connector to the rear rack. See figure 8.

NOTE: The reclosable straps can be used instead of the clips for attaching the switch and quick connector to the vehicle.

5. Attach a clip to the switch using a #8 x 3/8" screw. The switch can be attached at the front or rear of the vehicle.
6. Connect the quick connectors for the switch and the wire harness.
7. Check the direction of winch rotation. The cable should unwind when the "rope out" button is pushed. If the cable winds onto the winch instead of unwinding, check the battery harness. Red should connect to positive and black to negative. If the wire harness is correct, reverse the wires connected to the winch.

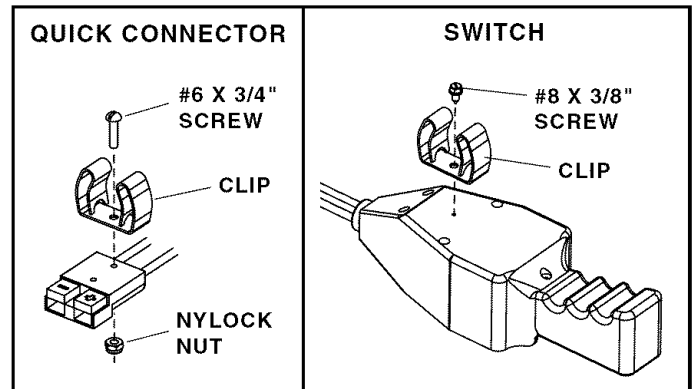

FIGURE 8

OPERATION



KEEP CLEAR OF WINCH AND WIRE ROPE WHEN WINCH IS UNDER LOAD.

The 3-Point Hitch Trailer is only designed for towing category 0 or 1 attachments. The total working weight of any attachment must not exceed 400 pounds.

When the hitch trailer is attached to the tow vehicle, the hitch pin used to connect the trailer to the vehicle hitch must be secured with the haircutter pin. Failure to use the haircutter pin could result in the hitch trailer disconnecting from the tow vehicle.

Do not operate this trailer without first reading the safety precautions in this manual and in the winch operator's manual.

Refer to the owner's manual of the attachment you are towing with the hitch trailer for the operation instructions for that particular attachment. Refer to the user's guide provided with the winch for the winch operation instructions. Refer to the following paragraphs for the adjustments pertaining to the hitch trailer.

WIDTH ADJUSTMENT

A category 0 attachment requires the hitch anchors to be moved to the inner locating holes on the trailer frame. A category 1 attachment requires the hitch anchors to be moved to the outer locating holes. Remove the haircutter pin and clevis pin to slide the hitch anchors to the proper position on the trailer frame for your particular attachment. See figure 9.

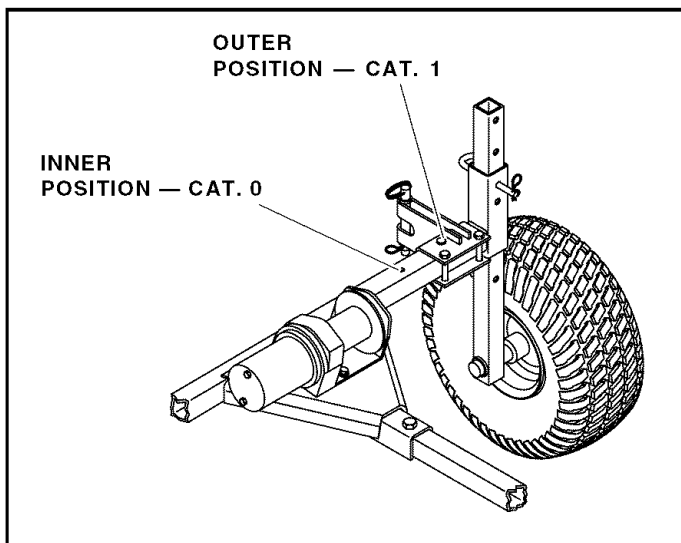

FIGURE 9

CONNECTING ATTACHMENT



DO NOT EXCEED 400 POUNDS OF ATTACHMENT WEIGHT. STABILITY OF TOWING VEHICLE COULD BE AFFECTED.

The category 0 or 1 pins on the sides of the attachment fit into the slots in the hitch anchors at each end of the trailer. To secure the attachment to the trailer, you must install a quick attach pin in each hitch anchor, with the quick attach pin installed behind the category pin. Then secure each quick attach pin with a haircutter pin. See figure 10.

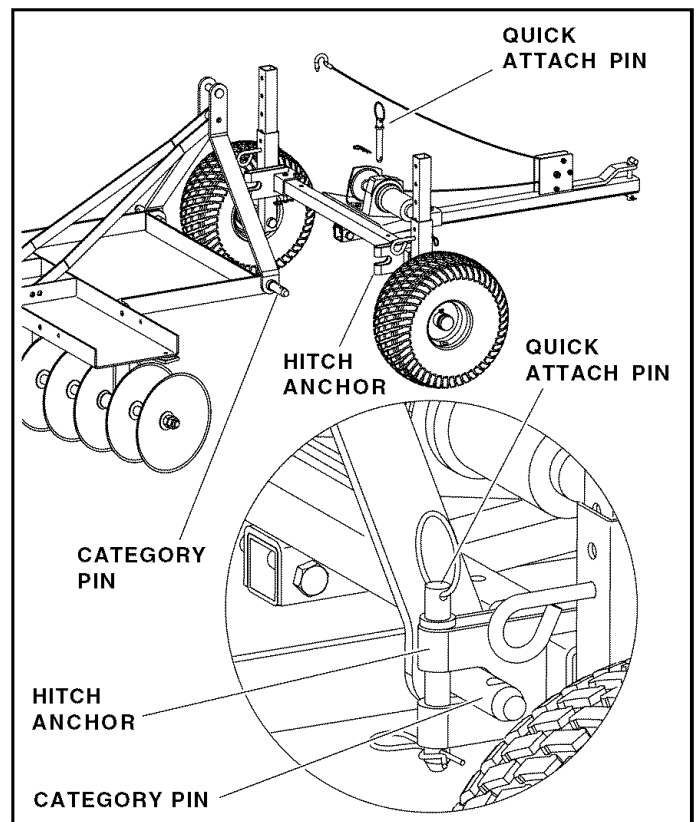

FIGURE 10

LEVELING ADJUSTMENT



DO NOT ADJUST TRAILER HEIGHT WITH ATTACHMENT RAISED! PERSONAL INJURY CAN RESULT.

The trailer height must be adjusted after the trailer is attached to the vehicle to obtain the best performance out an attached implement.

Holes in the trailer frame provide for a 1-inch height change. Holes in the axle assembly provide for a 2-inch height change. From the lowest setting, the trailer height can be raised 11 inches. Remove the haircotter pin to remove the height adjust pin. Install the pin in the upper or lower hole of the trailer frame and the appropriate hole of the axle assembly.

Adjust the trailer height so that the frame of the attached implement is horizontal during operation. If the implement will penetrate below ground level during operation, adjust the trailer height so that the implement is level while above ground and then lower the trailer a distance equal to the approximate operating depth of the implement. Make sure the axle assemblies are set at the same height. See figure 11.

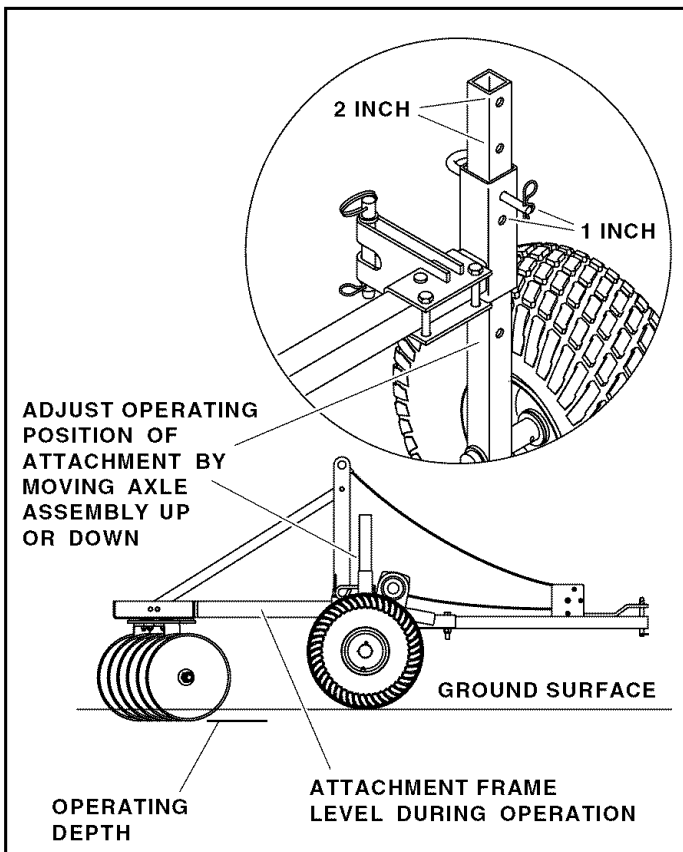

FIGURE 11

ATTACHMENT ADJUSTMENT

Use the switch on the tow vehicle to raise or lower the attachment. Push the "rope in" button on the switch to raise the attachment. Push the "rope out" button on the switch to lower the attachment.

When the attachment is in the lowered, operating position, there should be slack in the wire rope allowing the implement to follow the contour of the ground.

MAINTENANCE

1. Check for and tighten any loose hardware before each use.
2. Lubricate both wheel axles with grease before use each season.
3. Inspect wire cable on winch before each use and replace cable if necessary.
4. Refer to user's guide provided with winch for winch maintenance.
5. Remove all dirt and rust. Touch up paint before placing hitch trailer in storage.
6. Store hitch trailer inside a dry area.

NOTES

REPAIR PARTS FOR MODEL NO. 45-0353 3-POINT HITCH TRAILER

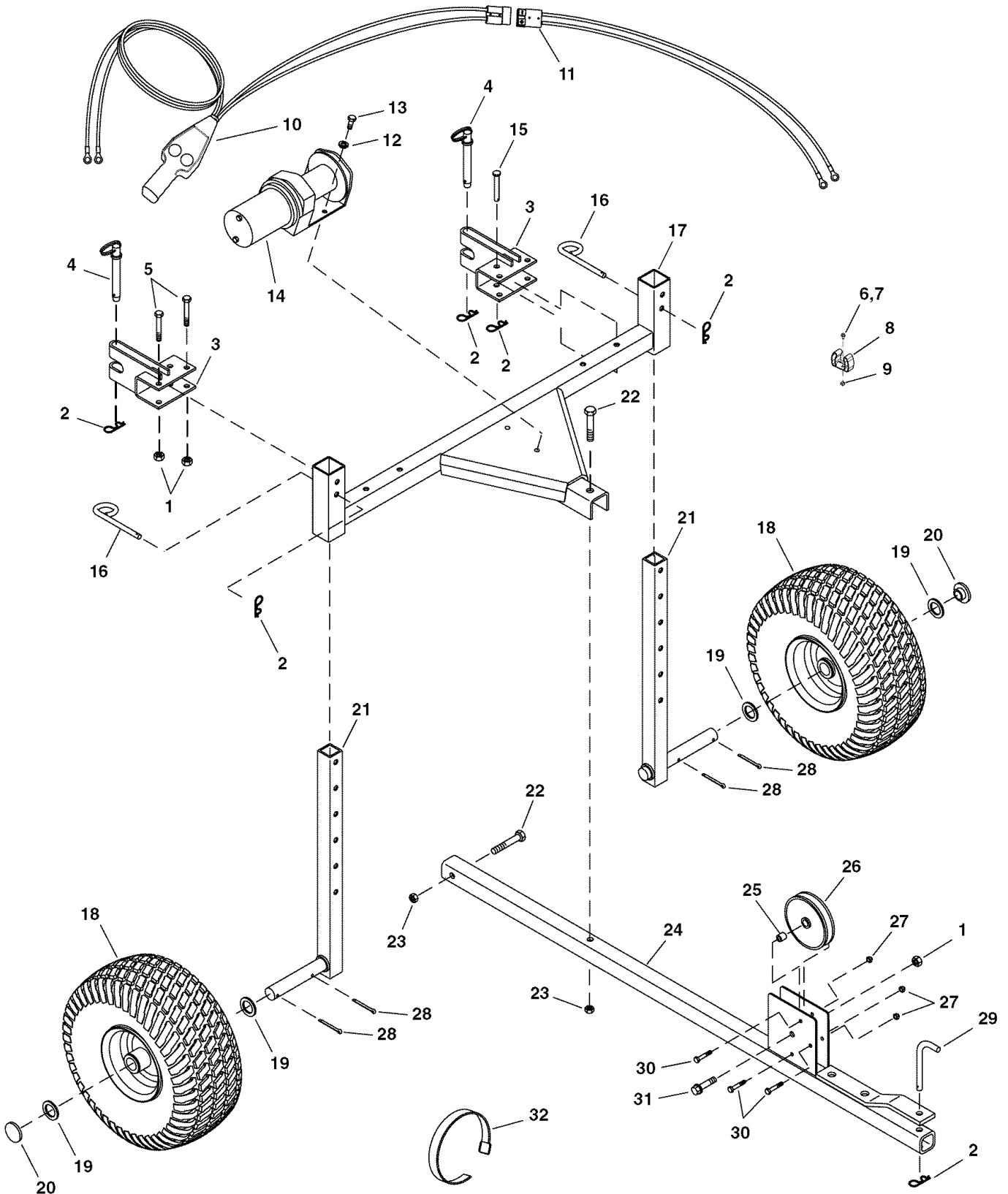

REPAIR PARTS FOR MODEL NO. 45-0353 3-POINT HITCH TRAILER

REF. NO.	PART NO.	QTY.	DESCRIPTION	REF. NO.	PART NO.	QTY.	DESCRIPTION
1	HA21362	5	Hex Nut, Nylock, 3/8"	17	64769	1	Trailer Frame Assembly
2	43343	7	Haircotter Pin, 1/8" x 2-3/8"	18	48965	2	Wheel, 15" x 6.00
3	64778	2	Hitch Anchor Assembly	19	43601	4	Washer, 1.59" x 1.032" x .060"
4	48967	2	Quick Attach Pin	20	43014	2	Hub Cap, 1-1/2"
5	43432	4	Hex Bolt, 3/8"-16 x 2-1/2" Lg.	21	64770	2	Axle Assembly
6	49383	1	Screw, #6 x 3/4"	22	43510	2	Hex Bolt, 1/2" x 2-3/4" Lg.
7	49385	1	Screw, #8 x 3/8"	23	712-3083	2	Hex Nut, Nylock, 1/2"
8	47397	2	Clip	24	64792	1	Drawbar Assembly
9	49384	1	Hex Nut, Nylock #6-32	25	24286	1	Spacer
10	65040	1	Switch Assembly	26	48980	1	Pulley Assembly
11	65039	1	Wire Harness Assembly	27	47189	3	Hex Nut, Nylock, 1/4"
12	43086	2	Lock Washer, 5/16"	28	43093	4	Cotter Pin, 1/8" x 1-1/2"
13	43063	2	Hex Bolt, 5/16"-18 x 1" Lg.	29	46065	1	Hitch Pin
14	WW2000V12	1	Winch	30	1509-69	3	Hex Bolt, 1/4" x 1-3/4"
15	43513	2	Clevis Pin, 3/8" x 3" Lg.	31	41576	1	Hex Bolt, 3/8" x 1-3/4"
16	23353	2	Height Adjust Pin	32	49232	3	Strap, Reclosable
					48975	1	Owner's Manual (not shown)

SpeedPart *the fastest way to purchase parts* www.speedepart.com

SpeedEPart *the fastest way to purchase parts* www.speedepart.com

REPAIR PARTS

Agri-Fab, Inc.
303 West Raymond
Sullivan, IL 61951
217-728-8388
www.agri-fab.com