

# OWNER'S MANUAL

**MODEL NO.  
625.384400**

**Caution:**

Read and Follow  
All Safety Rules and  
Operating Instructions  
Before First Use of  
This Product.

If you have questions when  
installing and using your wa-  
ter filter housing call this toll-  
free number...

**1-800-426-9345**

(M - F, 7 am - 8 pm, CST)

For repair or replacement  
parts, call this toll-free num-  
ber...

**1-800-366-7278**

See back cover for other  
Sears service numbers.

[www.KenmoreWater.com](http://www.KenmoreWater.com)

**SAVE THIS MANUAL**



## DELUXE MULTI-PURPOSE WATER FILTER HOUSING

- ◆ Safety Guides
- ◆ Installation
- ◆ Operation
- ◆ Cartridge Replacement
- ◆ Repair Parts

## SAFETY GUIDES / SPECIFICATIONS

▲ Please read this entire manual before installing and using your deluxe multi-purpose water filter housing. Be sure to follow all guides and steps carefully. Failure to follow them could cause personal injury or property damage.

▲ Check with your local public works department for plumbing codes. You must follow their guides as you install the water filter housing. In Massachusetts, plumbing codes of Massachusetts shall be adhered to. Consult with your licensed plumber.

▲ Use the filter on a potable, safe-to-drink, home COLD water supply only. The filter

cartridge will not purify water, or make it safe to drink. DO NOT use on HOT water (100°F, max.). Do not use with water that is microbiologically unsafe or of unknown quality without adequate disinfection before or after the system.

▲ Protect the water filter housing and piping from freezing. Water freezing in the housing will break it.

▲ Your deluxe multi-purpose water filter housing works on water pressures of 40 psi (minimum) to 100 psi (maximum). If your house pressure is over the maximum, install a pressure reducing valve in the water supply pipe to the water filter.

Min. - Max. Supply Water Pressure	40 - 100 psi
Min. - Max. Supply Water Temperature	40 - 100 °F
Inlet - Outlet Thread Size	3/4" NPT

### WARRANTY

#### FULL ONE YEAR WARRANTY ON DELUXE MULTI-PURPOSE WATER FILTER HOUSING

For one year from the date of purchase, Sears will replace this Deluxe Multi-Purpose Water Filter Housing, (except filter cartridge, which is purchased separately), free of charge, if defective in material or workmanship.

WARRANTY IS AVAILABLE BY SIMPLY RETURNING THE DELUXE MULTI-PURPOSE WATER FILTER HOUSING TO THE NEAREST SEARS STORE THROUGHOUT THE UNITED STATES.

This warranty gives you specific legal rights, and you may have other rights which vary from state to state.

Sears, Roebuck and Co., DEPT. 817 WA, Hoffman Estates, IL 60179

# TABLE OF CONTENTS

Planning Installation .....	3-4
Typical Installation Drawings / Tools and Materials Needed .....	4
Water Filter Housing Installation .....	5- 7
Filtering All House Water .....	5 - 6
Using Compression Fittings .....	5
Using Soldered Copper .....	5
Using Threaded Fittings .....	6
Filtering Water To One Faucet (Installing Under Sink) .....	7
Installing Filter Cartridge .....	7
Filter Cartridge Life / Replacement .....	8 - 9
Repair Parts .....	11

## PLANNING YOUR INSTALLATION

When planning your installation, first read the filter cartridge information on page 8, and decide where to locate the water filter housing. Then use the drawings on page 4 to guide you. There are many variables to consider as you plan. Some of these are:

- ✓ the water filter housing inlet and outlet internal threads are 3/4" NPT.
- ✓ existing plumbing type (copper, threaded, etc.)

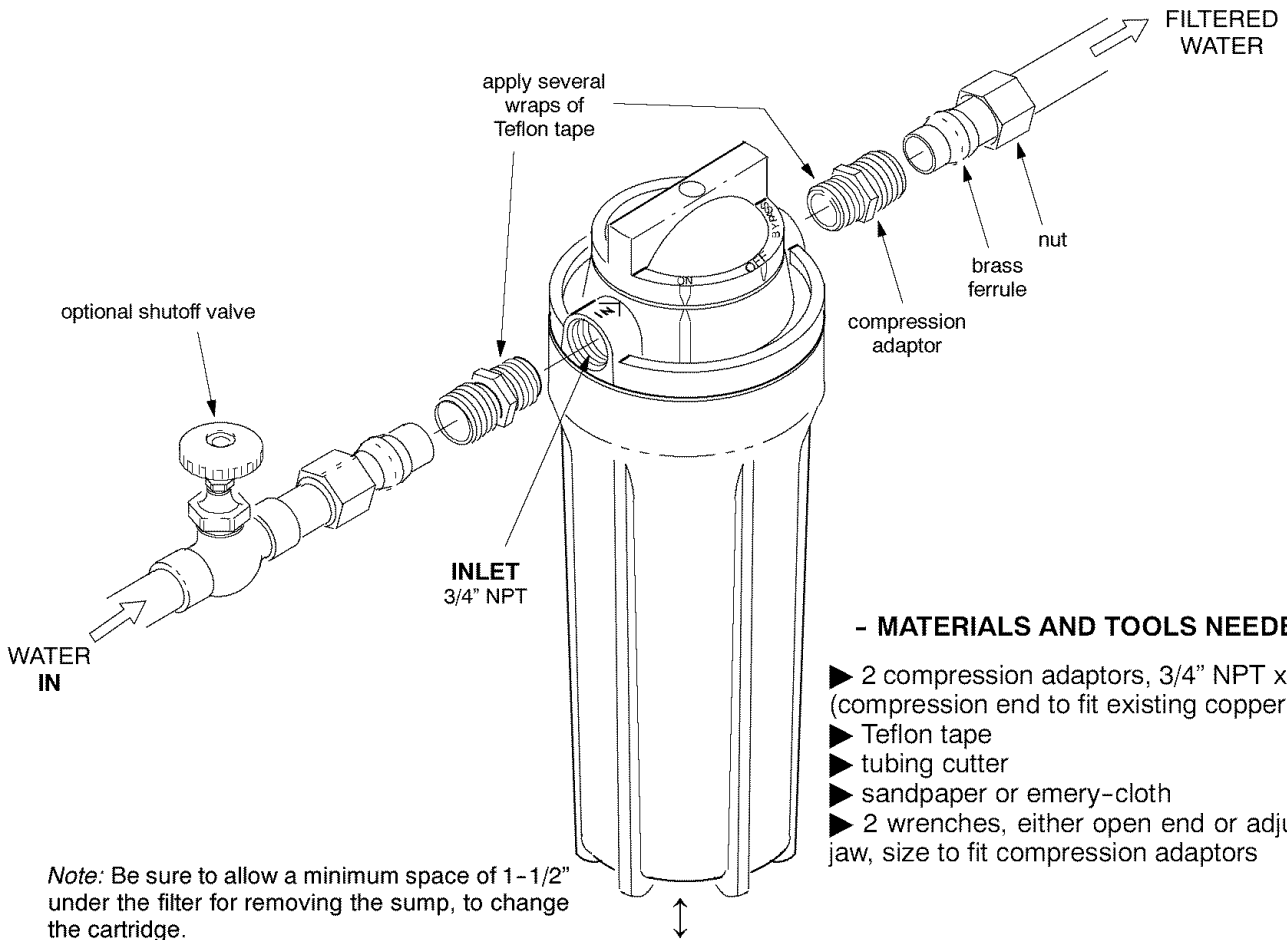
and nominal size (1/2", 3/4" etc.)

- ✓ tools you have and your plumbing skills
- ✓ cost of materials needed
- ✓ space available for installing the filter housing

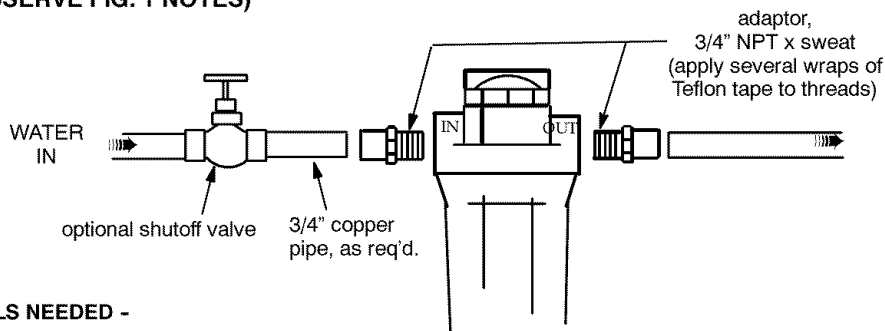
Make a simple sketch of your proposed installation and a list of plumbing materials you will need. Obtain everything you need before starting the installation. Be sure you have the tools required.

# TYPICAL INSTALLATIONS / TOOLS AND MATERIALS NEEDED

**FIG. 1** INSTALLATION ON COPPER PLUMBING USING COMPRESSION FITTINGS

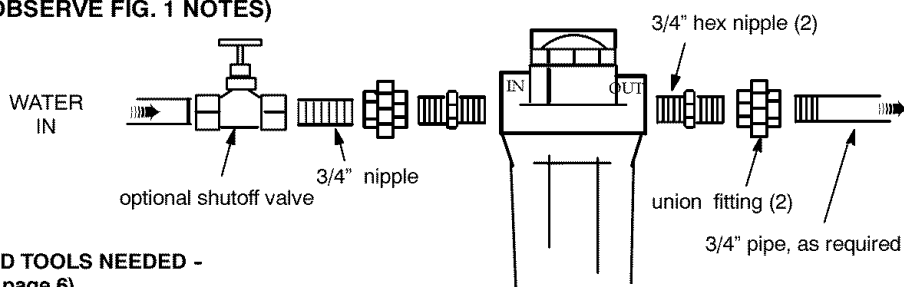


**FIG. 2** SOLDERED COPPER INSTALLATION  
(OBSERVE FIG. 1 NOTES)



**- MATERIALS AND TOOLS NEEDED -**  
(see page 5)

**FIG. 3** THREADED INSTALLATION  
(OBSERVE FIG. 1 NOTES)



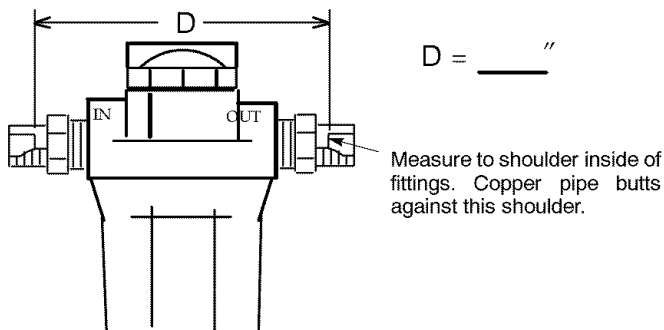
**- MATERIALS AND TOOLS NEEDED -**  
(see page 6)

## INSTALLATION STEPS

### WATER FILTER HOUSING ON HOUSE MAIN WATER PIPE, TO FILTER ALL HOUSEHOLD WATER

#### A. USING COMPRESSION FITTINGS, FIG. 1

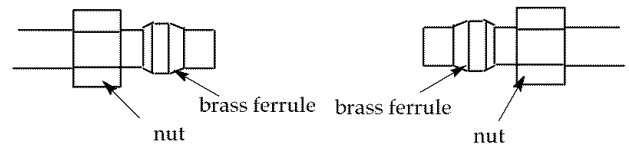
1. Apply several wraps of Teflon tape to the threads of both compression fittings.
2. CAREFULLY, turn the compression fittings into the water filter head inlet and outlet and tighten. **Do not cross-thread** and damage the threads. **Do not overtighten** and crack the head.
3. Remove the nut and brass ferrule from both compression fittings and set aside. Using a tape measure or ruler, measure the distance "D" as shown below. Mark this dimension below so you do not forget.



4. **CAUTION: Turn off the water supply** to the main pipe. Open a high and low faucet in the water system to drain the pipe.
5. On the main water pipe, where you will install the filter, mark the dimension "D". You will remove this section of pipe. **Before you begin to cut, double-check your measurement.**
6. Use a tubing cutter to remove the section of pipe. Remove all burrs and rough edges with the sandpaper or emery-cloth.
7. Place a nut and brass ferrule (from compression fittings) onto both pipe ends.

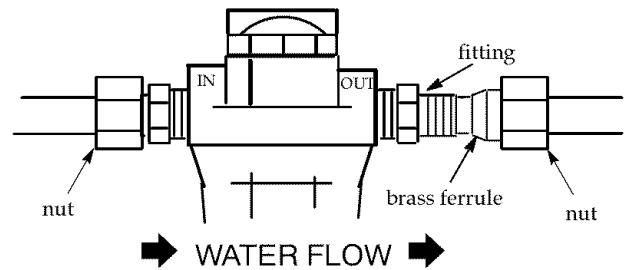
#### B. SOLDERED COPPER FITTINGS, FIG. 2

**MATERIALS AND TOOLS NEEDED:** You will need 2 sweat adaptors, 3/4" NPT x sweat (sweat end to fit your main water pipe), lead-free solder and flux, soldering torch, Teflon tape, sandpaper or emery-cloth, open end (to fit sweat adaptor) or adjustable jaw wrench.



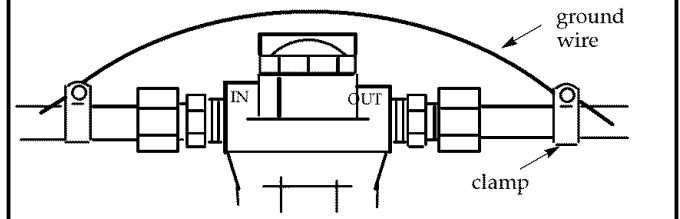
8. With the **inlet side of the water filter facing incoming water**, spread the pipes apart and fit both pipe ends into the compression fittings. Move a ferrule and nut up to the fitting. Then turn on and tighten the nut. *Hold the fitting with one wrench while tightening the nut with the other.* Repeat on the other side.

*Note: If water flow is from right to left ( ← ← ← ), be sure to turn water filter so inlet is to the right.*



9. **Before turning on the water supply** remove the sump from the filter head and install the filter cartridge (see page 9).

**IMPORTANT:** The house cold water pipe is often used to ground electrical outlets in the home. **Grounding protects you from electrical shock.** The water filter housing may have broken this ground. To restore, buy and install a #4 copper wire across the filter, tightly clamping at both ends as shown here.



**CAUTION: Heat created when soldering can damage the water filter housing.** Be sure to use the following procedures to protect the water filter.

1. **CAUTION: Turn off the water supply** to the main pipe. Open a high and low faucet, in the water system, to drain the pipe.

## INSTALLATION STEPS (cont.)

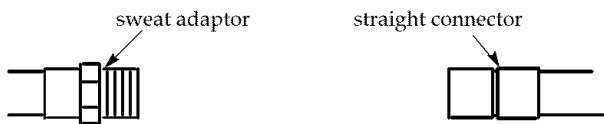
### WATER FILTER HOUSING ON HOUSE MAIN WATER PIPE, TO FILTER ALL HOUSEHOLD WATER

2. On the main water pipe where you will install the filter use a tubing cutter to remove a section of pipe about 12" long. Use sandpaper or emery-cloth to thoroughly clean and remove all burrs and rough edges from both pipe ends.

*Note:* When soldering, use **lead-free solder and flux only**. Be sure pipe and fittings are properly cleaned.

3. Solder a sweat adaptor onto one of the pipe ends.

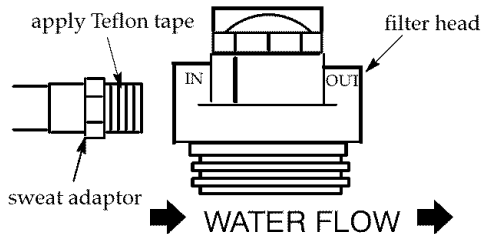
4. Place, but do not solder, a straight connector onto the other pipe end.



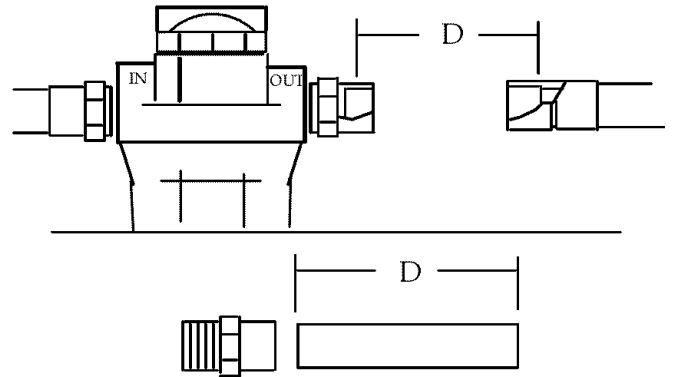
5. Remove the sump from the filter head and set the sump aside.

6. *After it cools*, apply several wraps of Teflon tape to the threads on the sweat adaptor fitting.

7. **Carefully** turn the filter head INLET (if water flow is from the left) onto the sweat adaptor fitting. If water flow is from the right turn the outlet side of the head onto the fitting. **Do not cross-thread or over-tighten** and crack the filter head.



8. Turn a sweat adaptor fitting into the other side of the filter head and **hand tighten only**. Using a tape measure or ruler measure the distance "D" as shown below. Mark this same dimension on a length of copper pipe. Cut the length of pipe.



9. Remove the sweat adaptor fitting from the filter head and solder to the cut length of pipe.

10. *After it cools*, apply several wraps of Teflon tape to the threads on the sweat adaptor fitting. Apply flux and place the pipe end of the soldered assembly into the straight connector. Then turn the adaptor end into the filter head and tighten.

11. Solder both sides of the straight connector.

12. **Before** replacing the sump and **turning on the water supply** install the filter cartridge (see page 8).

*Note:* **Read the grounding information on page 6**, and comply with the instructions if required to maintain continuity.

## C. THREADED PIPE AND FITTINGS, FIG. 3

**MATERIALS AND TOOLS NEEDED:** For threaded pipe installation you will need a pipe threading tool, pipe wrenches, pipe joint compound, union fittings and pipe nipples. Connect the filter housing as typically shown in FIG. 3, page 4. Observe the following:

■ Use pipe joint compound on all external threads.

■ Do not turn pipe or fittings too tightly into the filter head or you may break it.

■ It is important to have some linear movement in the house main water pipe. This will allow you to tighten union fittings without damaging the filter head if pipe lengths are not exact.

*Note:* **Read the grounding information on page 5**, and comply with the instructions if required to maintain continuity.

## INSTALLATION STEPS (cont.)

### WATER FILTER HOUSING UNDERSINK, TO FILTER WATER TO ONE FAUCET

**REFER TO PAGE 5.** If optional kits are used, follow instructions included with them.

1. Close the **cold** water side shutoff valve. (Usually, there already is a shutoff under the sink. If not, close the main water shutoff valve near the water meter or pressure tank.)
2. Cut and remove a section of the cold water pipe.
3. If plumbing with flexible tubing, hang or support the filter housing in some manner. If using rigid pipe, be sure to allow a minimum of 1-1/2" clearance under the filter for sump removal when changing the filter cartridge.

4. Use the plumbing procedures on page 5 if using compression fittings. Follow procedures on pages 5 and 6 for sweat copper and threaded pipe installation. **Be sure water flow is into the filter inlet side** and from the outlet side to the faucet.

*Note:* A grounding jumper wire is not required.

5. **Before turning on the water supply** remove the sump from the filter head and install the filter cartridge (see below).

### FILTER CARTRIDGE INSTALLATION

TURN TO PAGE 9 AND FOLLOW ALL STEPS UNDER "FILTER CARTRIDGE REPLACEMENT".

# FILTER CARTRIDGE / USEFUL LIFE / REPLACEMENT

## FILTER CARTRIDGE LIFE

Several variables determine how long a cartridge will last. These include:

1. where the water filter is installed (filtering all house water, or just to one faucet)
2. how much water you use
3. how much sediment, taste and/or odor, or other unwanted substance is in the water

Use the following information as a guide. However, no matter which type of cartridge you are using you will know **it is time to replace it when you first notice the return of the unwanted substance in your water or a substantial reduction in flow.**

Other filter cartridges are available from Sears to remove (1) sediments, (2) tastes and odors, (3) tastes, odors and chemical contaminants, and (4) tastes, odors and lead.

Many bad tastes and/or odors are removed from water by an activated carbon cartridge. It is most often used to remove chlorine taste and smell, usually to a single faucet such as the kitchen cold.

**(1) Sears Item No. 42-38478 (25 micron), or Item No. 42-38480 (5 micron):** Sediment cartridges remove sand, silt, clay, dirt, and other sediments from water. The 25 micron cartridge filters larger sediments from water, and allows higher flows at less pressure drop. The 5 micron cartridge filters finer sediments from water, usually to a single faucet. Cartridge life, when filtering water to one faucet, is about 6 months maximum. Cartridge life is less when filtering all house water. This time varies depending on the type of sediment cartridge.

When filtering sediments you will know it's time to replace the cartridge when water pressure drops to the single faucet, or to the entire house supply.

Filtering water to a single faucet, the filter cartridge may last for 6 months or more. Cartridge life is less when filtering all house water. If the cartridge is also

for lead or chemical contaminant removal, it is more important to replace it frequently.

*Note:* Small amounts of hydrogen sulfide (noticeable as "rotten egg" odor) may be reduced by taste and odor filters for a short time, quickly exhausting the carbon media. Consult your Sears store for proper continuous treatment.

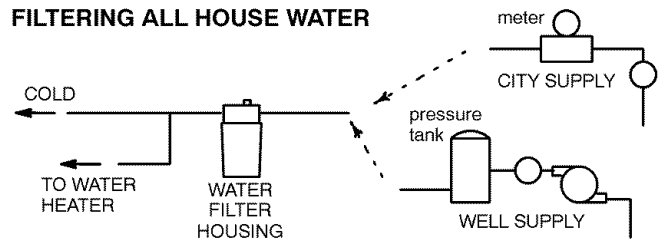
Sears has several **taste and odor filter cartridges** available. These filters are used to filter the water to one faucet and are not intended for whole house filtration. These are:

**(2) Sears Item No. 42-34370:** for 95% chlorine reduction,

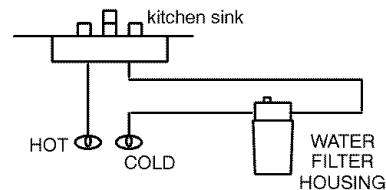
**(3) Sears Item No. 42-34365:** for 99% chlorine reduction, *plus* chemical contaminants

To filter sediments from *all* house water, locate the water filter housing on the main water supply pipe. Please ask your Sears associate about products that will remove taste and odors from your water throughout the home. You can also filter water to one faucet. For example, install the filter under the kitchen sink to filter the cold drinking water. *Typically taste and odor filters are installed to filter water to one faucet only.* Refer to the following drawings.

### FILTERING ALL HOUSE WATER



### FILTERING WATER TO ONE FAUCET

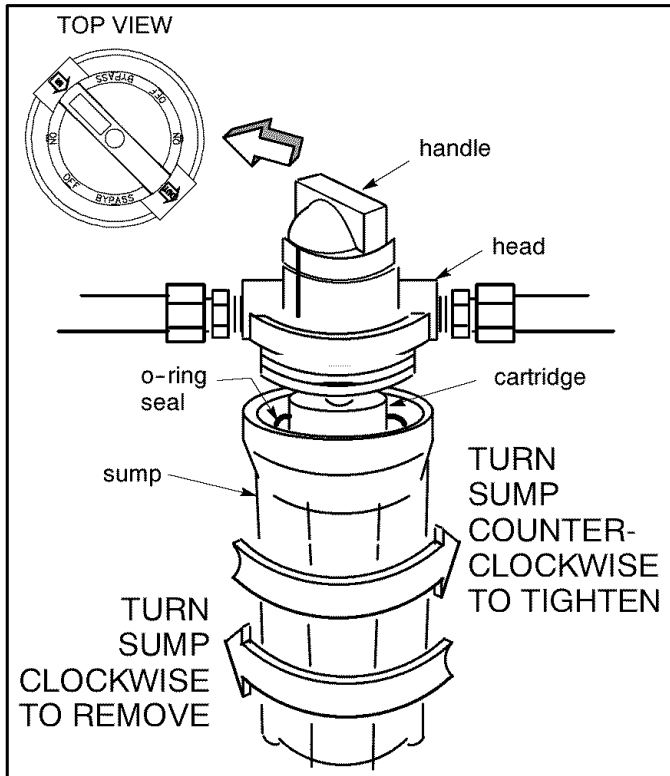




# FILTER CARTRIDGE / USEFUL LIFE / REPLACEMENT (cont.)

## FILTER CARTRIDGE REPLACEMENT

**CAUTION:** Never remove the sump with water pressure in the filter.



1. Turn the filter handle to the **OFF** or **BYPASS** position to relieve pressure in the filter. It is normal for some water to leak out.

Note: A **special wrench** (42-34334) is included for turning the sump head and removing the sump. See instructions for use on page 10.

2. Turn the sump off of the filter head to the left or clockwise. Be careful, the sump is full of water. Do not lose the large o-ring seal.

3. Be sure the inside of the sump is clean. Use warm, soapy water and rinse well.

4. Remove the wrapper from the new filter cartridge and insert the filter cartridge in the sump. Some cartridges fit either way, while others fit only one way.

Observe markings on the cartridge or on the wrapper.

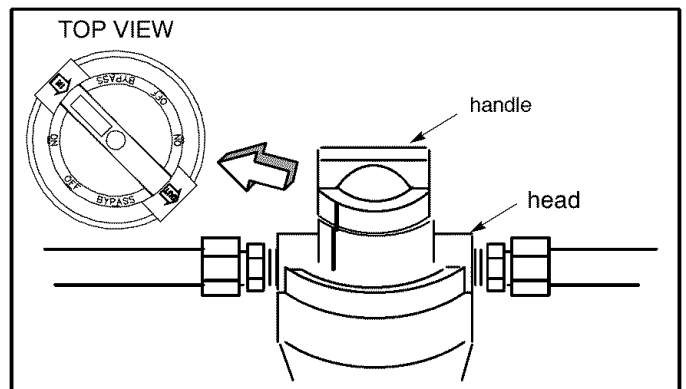
5. Lightly lubricate the o-ring seal in the sump with silicone grease or Vaseline. Be sure it is fully seated in the groove.

6. Hold the sump up to the filter head aligning the center hole in the cartridge with the protrusion on the bottom of the head.

Note: If the sump will not tighten up to the head you may have the cartridge in upside down or crooked. Take the cartridge out and check for correct orientation.

7. Being careful not to cross-thread turn the sump onto the filter head and tighten securely.

8. If the filter is installed for whole house water filtering, partially open a house faucet on the outlet side of the filter housing. Open the sink faucet if the filter is an undersink installation. **Then turn the filter handle to ON** allowing the filter housing to fill with water.



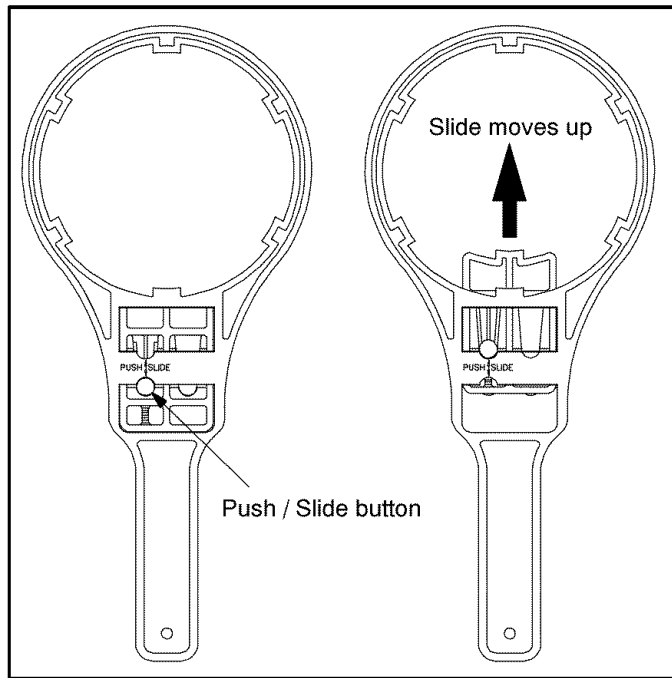
9. Close the house faucet. Then check for leaks between the sump and the head.

Note: If leaking turn off the water supply and depressurize the filter. Then disassemble the filter and check the o-ring for cuts, flat spots, etc., and sealing surfaces for foreign material. Relubricate the o-ring with silicone grease or Vaseline and carefully press into the groove in the sump.

## FILTER CARTRIDGE / USEFUL LIFE / REPLACEMENT (cont.)

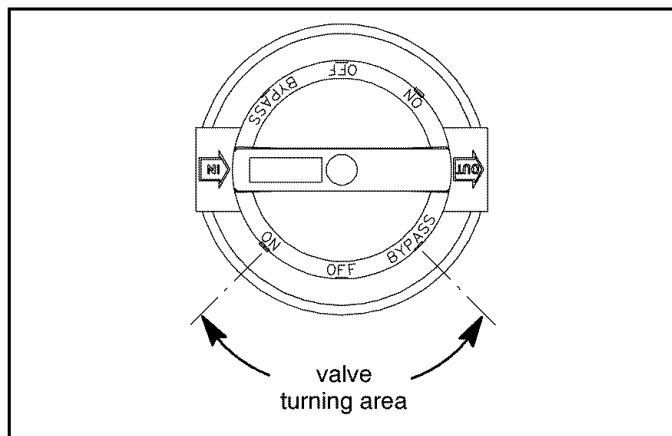
The adjustable filter wrench provided is intended to help turn the valve to the "Off", "On" or "Bypass" positions and remove the sump for easy filter changes.

**Turning the valve** - The "push/slide" button on the wrench will need to be pushed in and the slide moved up into the wrenching area to fit on the valve.

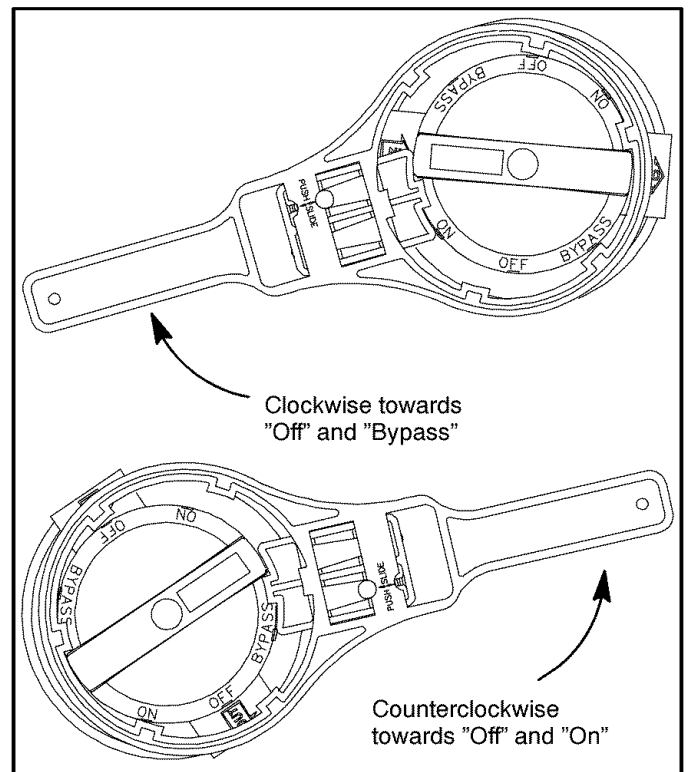


The valve turns clockwise from the "On" position towards the "Off" and "Bypass" positions and counterclockwise from the "Bypass" position towards the "Off" and "On" positions.

**Caution:** Forcing the valve beyond the "On" or "Bypass" positions will damage the valve.



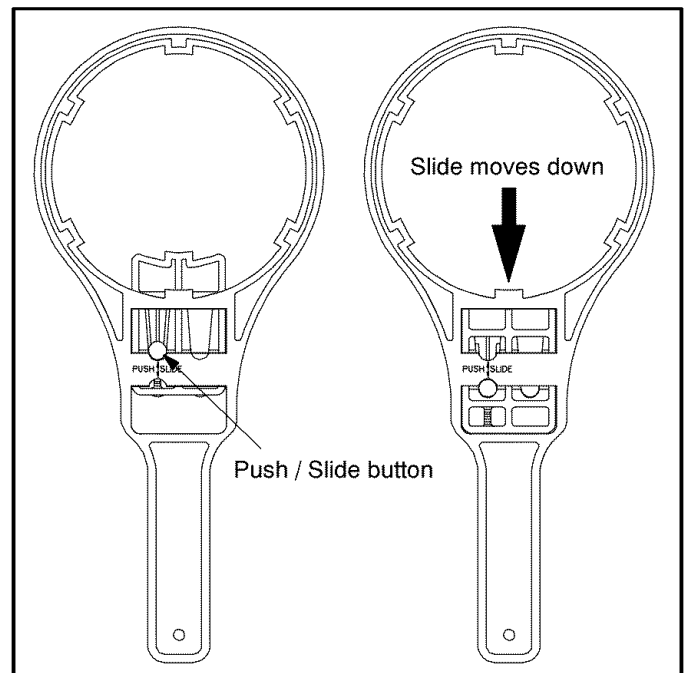
The valve has a pressure relief built in, so when turning the valve there will be a small amount of water coming out from under the top cap as the valve is turned from position to position.



**Removing the sump** - The slide will need to be pushed back into the wrench handle to open up the wrenching area, if the slide is in the wrenching area. Push the "push/slide" button on the wrench in, and push the slide into the wrench handle.

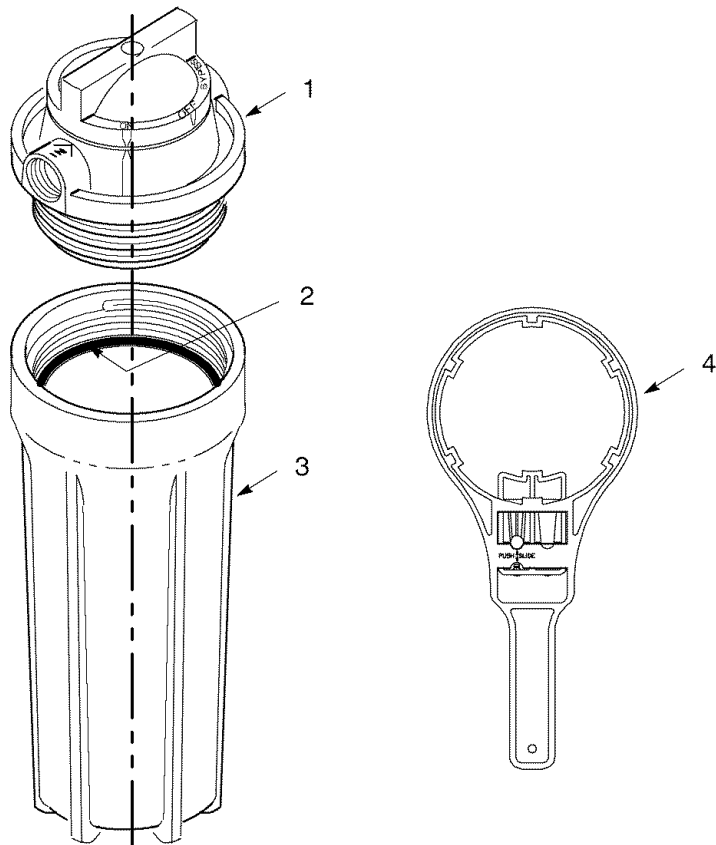
**Note:** Remember to turn the valve to "Bypass" or "Off" before removing the sump.

To remove the sump, turn it counterclockwise.



## REPAIR PARTS

### Kenmore Deluxe Multi-Purpose Water Filter Housing, Model No. 625.384400



KEY NO.	PART NUMBER	DESCRIPTION
1	7164944	Head Assembly
2	42-34345	O-ring, 3-7/8" I.D. x 4-1/8" O.D.
3	7156543	Sump
4	42-34334	Sump Removal Wrench
◆	7228798	Owners Manual
♣	42-38478	Sediment Cartridge, 25 micron
♣	42-38480	Sediment Cartridge, 5 micron
♣	42-34370	Taste & Odor Cartridge, 95% chlorine reduction *
♣	42-34373	Premium Taste & Odor Cartridge, 98% chlorine reduction *
♣	42-34365	Taste & Odor / Chemical Contaminate Cartridge *

◆ Not illustrated.

♣ Available options from Sears at the time of this printing, not illustrated, and not included with Water Filter Housing.

\* Not to be used for whole house applications.

# OWNERS MANUAL

**MODEL NO.**  
**625.384400**

The model number of your deluxe water filter housing is found on the rating decal, on the filter sump.

When requesting service or ordering parts, always provide the following information:

- ◆ Product Type
- ◆ Model Number
- ◆ Part Number
- ◆ Part Description

[www.KenmoreWater.com](http://www.KenmoreWater.com)



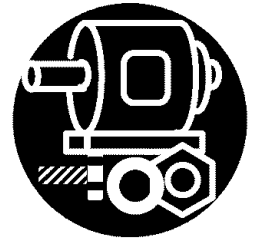
## DELUXE MULTI-PURPOSE WATER FILTER HOUSING

For the repair or replacement parts you need

Call 7 am - 7 pm, 7 days a week

**1 - 800 - 366 - PART**

(1 - 800 - 366 - 7278)



For in-home major brand repair service

Call 24 hours a day, 7 days a week

**1 - 800 - 4 - REPAIR**

(1 - 800 - 473 - 7247)



For the location of a  
Sears Repair Service Center in your area

Call 24 hours a day, 7 days a week

**1 - 800 - 488 - 1222**



For information on purchasing a Sears  
Maintenance Agreement, or to inquire  
about an existing Agreement

Call 9 am - 5 pm, Monday - Saturday

**1 - 800 - 827 - 6655**



**SEARS**  
**REPAIR SERVICES**

*America's Repair Specialists*