

Freestanding Gas Range

Estufa Autoestable de Gas
Cuisinière à gaz amovible

Use and Care Manual

Guide d'utilisation et d'entretien
Manual de uso y cuidado

for Models beginning with HGS

PLEASE READ ENTIRE INSTRUCTIONS BEFORE PROCEEDING.

IMPORTANT: Save these instructions.

INSTALLER: Please leave these instructions with this unit for the owner.

OWNER: Please retain these instructions for future reference.

Household Appliances

BOSCH

A Special Message to Our Customers

Dear Bosch Range Owner:

Thank you and congratulations on the purchase of your Bosch Gas Range. Whether you are an expert chef or an aspiring cook, we know that your new range will exceed your expectations. Decades of knowledge and experience are built into this range making it among the highest quality, most versatile and most efficient available.

We ask that you read this manual thoroughly before using your new range. Please pay particular attention to the safety precautions printed at the front of this book and the numerous safety hints and cautions placed throughout. Also, be sure to familiarize yourself with the proper operation of the range and its cleaning and maintenance procedures. Adherence to these instructions and procedures will assure that you realize the full potential of your new Bosch range as well as maintain it for years of dependable use.

Thank you and good cooking,

BSH Home Appliances Corporation



WARNING

When used in accordance with its intended purposes and properly cared for, your new Bosch range has been designed to be a safe, reliable appliance. Read all instructions carefully before using this range. These precautions will reduce the risk of burns, electric shock, fire, and injury to persons. Do not operate the oven or cooktop controls if the glass is broken. Food splatter or cleaning solution may penetrate a broken control panel and create a risk of electric shock. Contact a qualified technician immediately should your glass control panel become broken. When using kitchen appliances, basic safety precautions must be followed, including those in the following pages.

IMPORTANT SAFETY NOTICE

The California Safe Drinking and Toxic Enforcement Act requires the Governor of California to publish a list of substances known to the state to cause cancer, birth defects or other reproductive harm, and requires businesses to warn customers of potential exposure to such substances.

The burning of gas cooking fuel and the elimination of soil during self-cleaning can generate small amounts of Carbon Monoxide.

The fiberglass insulation in self-clean ovens gives off very small amounts of formaldehyde during the first several cleaning cycles.

California lists formaldehyde as a potential cause of cancer. Carbon Monoxide is a potential cause of reproductive toxicity.

Exposure to these substances can be minimized by:

1. Providing good ventilation when cooking with gas
2. Providing good ventilation during and immediately after self cleaning the oven.
3. Operating the unit according to the instructions in this manual.

The Bosch range referred to throughout this manual is manufactured by BSH Home Appliance Corp.

Table of Contents

Important Safety Instructions	1
Getting Familiar with Your Range	4
Setting Up Your Range	
Setting and Changing the Clock	6
Setting the Functions	7
Accessing and Using the Select Functions Menu	7
Volume	8
Change Temperature	8
Temperature Format	8
Time Format	8
Lock Keys	8
Language Option	8
Clock Display	9
Oven Temperature Offset	9
Demo Mode	9
Reset Defaults	9
Sabbath Feature	9
The Cooktop	
Cooktop Features	10
Cooktop Operation	11
The Oven	
Oven Modes and Features	12
Oven Modes and Features - Bake and Convection Bake	13
Oven Modes and Features - Broil	14
Oven Modes and Features - Convection Roast	15
Oven Modes and Features - Dehydrate (HDS24 and HDS25 models only)	16
Selecting the Oven Mode	17
Using the Timer (s)	18
Using Timed Cook	19
Using the Probe (HDS25 models only)	20
The Warming Drawer (HDS24 and HDS25 models only)	21
Care and Cleaning	
Cooktop	23
Oven	24
Self Help, Maintenance, Etc.	
Cookware Selection Guide	27
Maintenance	
Removing the Oven Door	28
Replacing the Oven Light	28
Self Help	29
Customer Service and Warranty	32



Important Safety Instructions

Please read all instructions before using this appliance.

APPLIANCE SAFETY

- This appliance must be properly installed and grounded by a qualified technician. Connect only to properly grounded outlet. Refer to Installation Instructions for details. Have the installer show you where the gas shut-off valve is.
- This is a high-tech appliance. Service should only be performed by an authorized service technician who has undergone training for this specific type of unit. Unauthorized service technicians may not be familiar with the sophisticated workings of this appliance, and may therefore cause damage to the unit or create a hazard. Contact the nearest authorized service center for examination, repair or adjustment.
- Do not repair or replace any part of the range unless specifically recommended by an authorized service technician.
- Do not operate this appliance if it is not working properly or if it has been damaged, until an authorized servicer has examined it.
- Use this appliance only for its intended use as described in this manual. If you have any questions, contact the manufacturer.
- Do not cover or block any openings on this appliance.
- Do not use corrosive chemicals, vapors, flammables or nonfood products in this appliance. This type of range is specifically designed to heat or cook food. It is not designed for industrial or laboratory use. The use of corrosive chemicals in heating or cleaning will damage the appliance and could result in injury.
- In the event that personal clothing or hair catches fire, **DROP AND ROLL IMMEDIATELY** to extinguish flames.
- Do not allow children to use this appliance unless closely supervised by an adult. Children and pets should not be left alone or unattended in the area where the appliance is in use. They should never be allowed to sit or stand on any part of the appliance or to play in its vicinity, whether or not the appliance is in use.



WARNING

- ALL RANGES CAN TIP.
- INJURY TO PERSONS COULD RESULT.
- INSTALL ANTI-TIP DEVICE PACKAGED WITH RANGE.

SEE INSTALLATION INSTRUCTIONS.



CAUTION

Items of interest to children should not be stored in the range, in cabinets above the range or on the backsplash of the range. Children climbing on the range to reach items could be seriously injured.



WARNING

If the information in this manual is not followed exactly, a fire or explosion may result causing property damage, personal injury or death.

- Do not store or use combustible materials, gasoline or other flammable vapors and liquids in the vicinity of this or any other appliance.
- WHAT TO DO IF YOU SMELL GAS:
 - Do not try to light any appliance.
 - Do not touch any electrical switch.
 - Do not use any phone in your building.
 - Immediately call your gas supplier from a neighbor's phone. Follow the gas supplier's instructions.
 - If you cannot reach your gas supplier, call the fire department.

Installation and service must be performed by a qualified installer, authorized service agency or the gas supplier.



PERSONAL SAFETY WARNING

To reduce the risk of injury to persons, in the event of a grease fire, observe the following:

- In the event of a grease fire, **SMOTHER FLAMES** with a close-fitting lid, cookie sheet, or other metal tray, then turn off the elements. **BE CAREFUL TO PREVENT BURNS.** If the flames do not go out immediately, **EVACUATE AND CALL THE FIRE DEPARTMENT.**
- Do not use water, including wet dishcloths or towels, on grease fires. A violent steam explosion may result.
- **SMOTHER FLAMES** from other types of food fires with baking soda. **NEVER** use water on cooking fires.
- **NEVER PICK UP A FLAMING PAN.** You may be burned.
- **ALWAYS** have a working **SMOKE DETECTOR** near the kitchen.
- **LEAVE THE HOOD VENTILATOR ON** when flambéing food.
- **Use an extinguisher ONLY IF:**
 - You know you have a Class ABC extinguisher, and you already know how to operate it.
 - The fire is small and contained in the area where it started.
 - The fire department is being called.
 - You can fight the fire with your back to an exit.

This range is intended for residential use only. It is not approved for outdoor use.



Important Safety Instructions

Please read all instructions before using this appliance.

COOKTOP SAFETY

- When using the cooktop, **DO NOT TOUCH THE HOT COOKING AREA OR THE IMMEDIATE SURROUNDING AREA.** Areas adjacent to the burners may become hot enough to cause burns. Never let clothing, potholders, or other flammable materials come in contact with a cooking area until it has cooled.
- Use high heat settings on the cooktop only when necessary. Heat oil slowly on no more than a low-medium setting, to avoid bubbling and splatter. Hot oil is capable of causing extreme burns and injury.
- Never move a pan of hot oil, especially a deep fat fryer. Wait until it is cool.
- Never leave the cooktop unattended. Boilovers can cause smoke and possibly damage the cooktop.
- Hold the handle of the pan to prevent movement of the utensil when stirring or turning food.
- Other than the use of metal pans, only certain types of glass, heatproof glass ceramic, ceramic, or other glazed utensils are suitable for cooktop use. Other types of utensils may break with sudden temperature changes. Use only on low or medium heat settings according to the utensil manufacturer's directions.
- Take care that drafts like those from fans or forced air vents do not blow flammable material toward the flames or push the flames so that they extend beyond the edges of the pan.
- Always position handles of utensils inward so they do not extend over adjacent work areas, burners or the edge of the cooktop.
- Do not clean the cooktop while it is still hot. Some cleaners produce noxious fumes when applied to a hot surface.

SELF-CLEANING SAFETY

- Confirm that the door locks and will not open once the door lock icon appears. If the door does not lock, touch OFF and do not run Self-Clean. Phone 800/944-2904 for service.
- **Note:** During a normal Self Clean cycle, the door does not lock at the beginning of the cycle; However, it does lock prior to reaching the high self clean temperatures. In a Delayed Self-Clean cycle, the door locks immediately.
- Do not clean the oven gasket. It is essential for a good seal. Care should be taken not to rub, damage, move or remove the oven gasket.
- Do not use commercial oven cleaners or oven liner protective coatings of any kind in or around any part of the oven.
- Clean only oven parts listed in this manual.
- Before self-cleaning the oven, **remove the broiler pan, oven racks, oven probe and other utensils and wipe out excess soft spillage.**

REGARDING PET BIRDS:

Birds have very sensitive respiratory systems. Keep pet birds out of the kitchen or other rooms where kitchen fumes could reach them. During self clean, fumes are released that may be harmful to birds. Other kitchen fumes such as overheating margarines and cooking oils may also be harmful.

OVEN SAFETY

To reduce the risk of fire:

- Do not store flammable materials in, on or near the oven.
- Do not use water or a wet rag or towel on a grease fire. Smother fire with baking soda or use a dry chemical or foam-type (ABC) extinguisher.
- Have an appropriate fire extinguisher available, nearby, highly visible and easily accessible near the oven.
- Do not use the oven's cavity for the storage of any item, especially anything that is combustible, toxic, or flammable.
- If materials inside the oven should ignite, keep oven door closed. Turn off oven, disconnect the circuit at the circuit breaker box and turn off gas supply at shut off valve.
- Do not block any vent openings. NEVER cover any slots, holes and passages in the oven bottom or cover an entire rack with materials such as aluminum foil. Doing so blocks air flow through the oven and may cause carbon monoxide poisoning. Aluminum foil linings may also trap heat, causing a fire hazard.
- Never use the oven to warm or heat a room. This can damage the oven parts and may result in carbon monoxide poisoning or overheating of the oven.
- Never wear loose-fitting or hanging garments while using the appliance. Be careful when reaching for items stored over the range. Flammable material could be ignited if brought in contact with hot surface units or heating elements and may cause severe burns.
- Do not allow anyone to climb, stand, lean, or sit on any part of the oven, nor to hang on the oven door, warming drawer, or storage drawer. This can damage the range, and the unit may tip over, potentially causing severe injury.
- Have the installer show the location of the gas shutoff valve and the circuit breaker or fuse. Mark the circuit breaker or fuse for easy reference.

WARMING DRAWER SAFETY

To reduce the risk of fire, electric shock, or injury to persons:

- Do not use the warming drawer for storage. Flammable or combustible material may ignite, and toxic material could produce toxic vapors or explode.
- Exercise caution when opening the drawer-standing to the side, open the door slowly and slightly to let hot air and/or steam escape, keeping your face clear of the opening and making sure there are no children or pets near the unit. Only after the release of hot air and/or steam should you proceed to access the warming drawer. Unless needed for cooking or cleaning purposes, keep drawer shut, and do not leave the drawer open unattended.
- Do not place food in unopened containers in the warming drawer. Pressure could build up and cause containers to burst.



Important Safety Instructions

ADDITIONAL PRECAUTIONS FOR GAS-POWERED APPLIANCES:

- If you smell gas, your installer has not done a proper job of checking for leaks. If the connections are not perfectly tight, you can have a small leak and, therefore, a faint smell. Finding a gas leak is not a "do-it-yourself" procedure. Some leaks can only be found with the burner control in the ON position and this must be done by a qualified service technician. See warning, "What to do if you Smell Gas.", page 1.
- In the event that a burner goes out and gas escapes, open a window or door. Do not attempt to use the cooktop until the gas has had time to dissipate. Wait at least five minutes before using the range.
- Do not hang articles from any part of the appliance or place anything against the oven. Some fabrics are quite flammable and may catch on fire.
- If the range is near a window, be certain the curtains do not blow over or near the cooktop burners. They could catch on fire.
- When using the cooktop, do not touch the burner grates or the immediate surrounding area. Areas adjacent to the burners may become hot enough to cause burns.
- Never leave the cooktop unattended when in use. Boilovers cause smoking and greasy spillovers that may ignite. More importantly, if the burner flames are smothered, unburned gas will escape into the room. See warning, "What to do if you Smell Gas", page 1.
- Avoid high flame settings with a pan larger than the grate or with one that spans more than one burner, for prolonged periods of time. That can result in poor combustion that results in harmful by-products.
- For proper lighting performance of the burners, keep the ignitor ports clean. It is necessary to clean these when there is a boilover or when the burner does not light even though the electronic ignitors click.
- After a spill or boilover, turn off the burner and allow cooktop to cool. Clean around the burner and burner ports. After cleaning, check for proper operation.
- Be sure all cooktop controls are turned off and the cooktop is cool before using any type of aerosol cleaner on or around the cooktop. The sprayed chemicals could ignite or cause hot metal parts to corrode.
- Grease is flammable. Let hot grease cool before attempting to handle it. Avoid letting grease deposits collect. Clean after each use.
- Do not allow flames to spread around or over the rim of pan that contains grease. A grease fire could be ignited.
- Always place pan on burner before turning it on. Be sure you know which knob controls which burner. When cooking is complete, turn the burner off before removing the pan.

RANGE SAFETY

- In order to prevent possible burn injury while using the appliance, tie long hair so that it does not hang loose, and do not wear loose fitting clothing or hanging garments, such as ties, scarves, jewelry, or dangling sleeves. Avoid reaching or leaning over the appliance. Be aware that certain clothing and hair sprays may contain flammable chemicals.
- The burners may be hot even though they are not on. Interior surfaces of an oven become hot enough to cause burns.
- Do not touch burners or interior surfaces of oven during operation.
- During and after use, do not touch or let clothing or other flammable materials contact the burners or the interior surfaces of the oven until they have had sufficient time to cool.
- The trim on the sides of the oven door may become hot enough to cause burns.
- Exercise caution when opening the door-standing to the side, open the door slowly and slightly to let hot air and/or steam escape, keeping your face clear of the oven opening and making sure there are no children or pets near the unit. Only after the release of hot air and/or steam should you proceed with your cooking. Unless needed for cooking or cleaning purposes, keep doors shut, and do not leave open doors unattended.
- Do not heat unopened food containers. Build-up of pressure may cause the container to burst and cause injury.
- Always place oven racks in desired location while oven is cool. If a rack must be moved while oven is hot, do not let potholder contact the hot heating elements.
- Use only dry potholders. Moist or damp potholders on hot surfaces may result in burns from steam. Do not let potholder touch hot heating elements. Do not use a towel or other bulky cloth.
- Keep the oven free from grease build up.
- Do not place food directly on oven bottom.
- When using cooking or roasting bags in the oven, follow the manufacturer's directions.
- Do not use aluminum foil to line oven bottoms. Improper installation of aluminum foil may result in a risk of electric shock or fire.
- To avoid electric shock, do not operate the oven without the light bulb cover in place.

Getting Familiar with Your Range

Parts Included with Your Dual Fuel Range:

1. Use & Care Manual
2. Installation Instructions
3. AHAM Anti-Tip Brochure
4. Bosch Cookbook (HGS24 and HGS25 models)
5. Probe (HGS25 models)
6. Telescopic Rack (HGS25 models)
7. Anti-Tip Bracket
8. Screws for Anti-Tip Bracket
9. Registration Card
10. Incandescent Lights (not visible)
11. Oven Control
12. Panel and Knob
13. Broil Burner (not visible)
14. Convection Fan and Element (not visible)
15. Probe Receptacle (HGS25 models)
16. Rack Positions
17. Oven Gasket
18. Model & Serial # Plate
19. Bake Burner (not visible)
20. Door Lock (not visible)
21. Oven Rack Back
22. Oven Rack Front
23. Broiler Pan
24. Warming Drawer(HGS24 and HGS25 models)
25. Warming Drawer Rack (HGS24 and HGS25 models)
26. Burner Grates (2)
27. Burner Caps (4)
28. Oven Vent

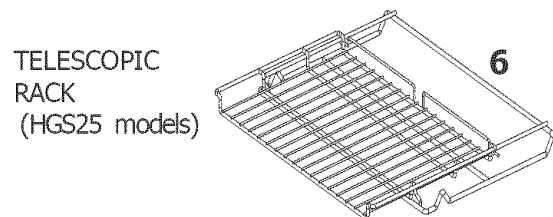
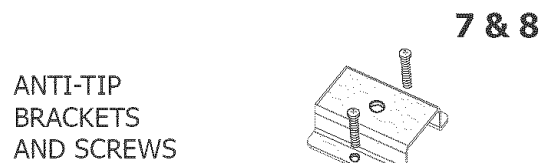
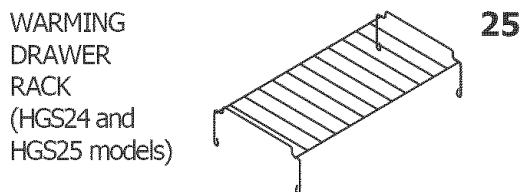
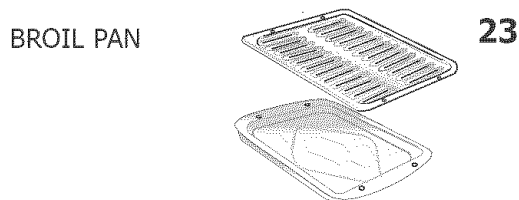
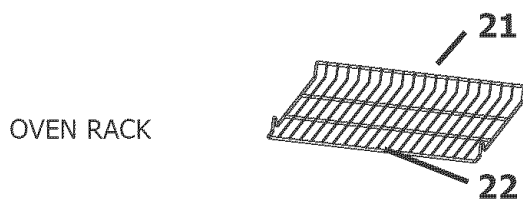
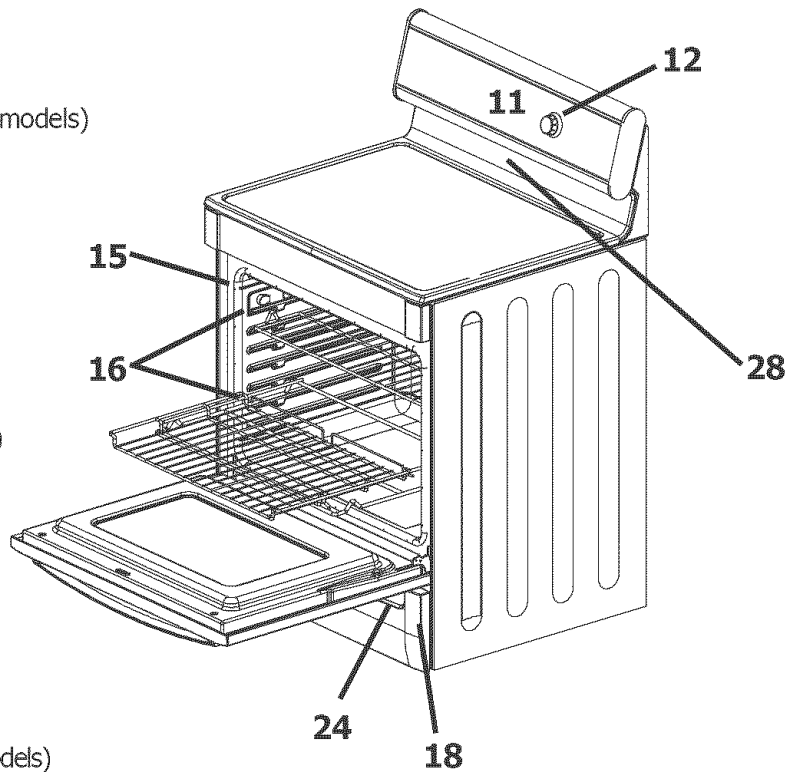

Actual parts are larger than depicted in above graphics.

Getting Familiar with Your Range

The Oven Control Panel

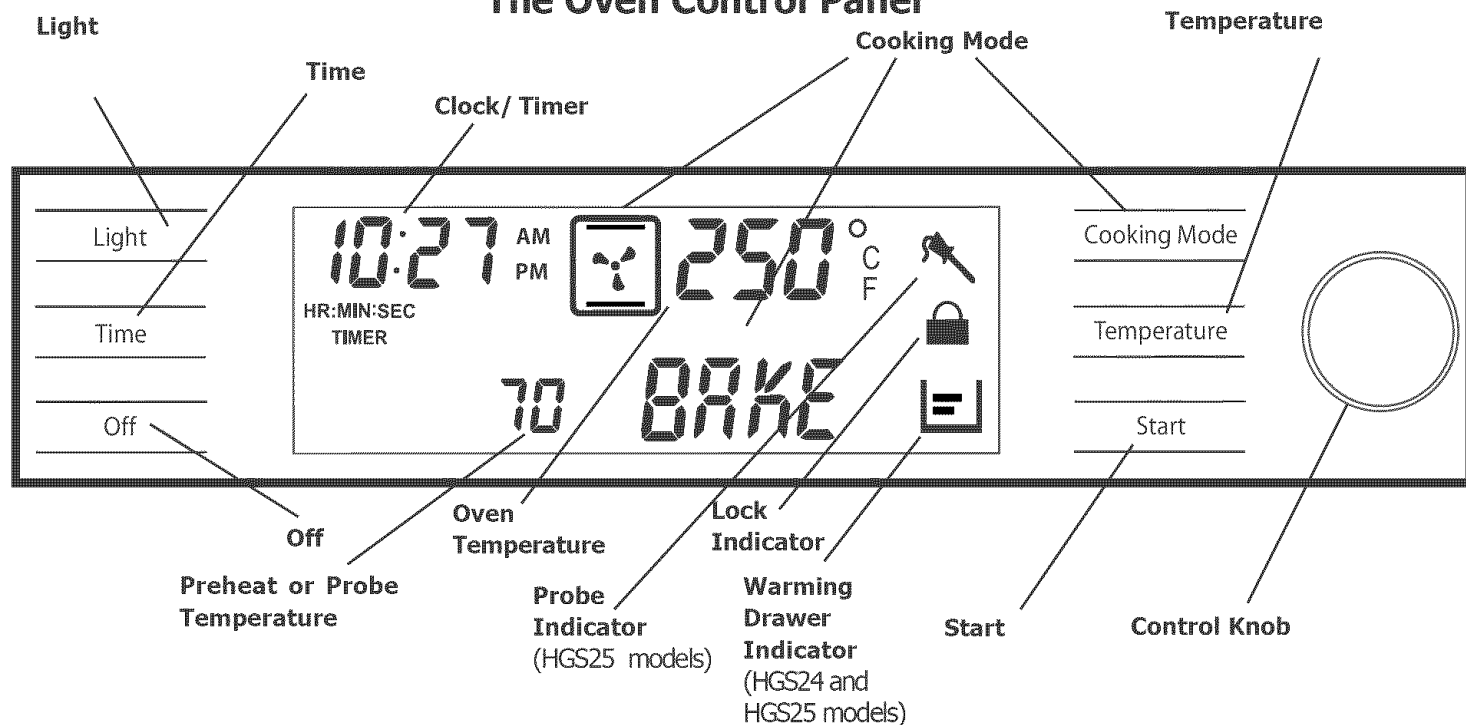

Display Window Features

CLOCK– Shows the time of day with a 12-hour or 24-hour clock option.

COOKING MODE - Touch pad to display cooking mode.

COOKING OR TIMED MODE– Shows the number of hours and minutes the oven will be “on.” Cooking mode icon is also displayed when cooking mode is selected.

CONTROL KNOB - Used to set the clock and timers, select cooking mode and temperature. Turn clockwise to increase and turn counterclockwise to decrease.

LIGHT - Touch pad to turn oven light on or off.

DOOR LOCK INDICATOR - Icon is displayed during the self-clean mode when the door is locked. DO NOT attempt to open the door until the lock symbol is no longer present.

OFF - Touch pad to turn off oven and/ or warming drawer.

OVEN TEMPERATURE - Shows the oven temperature selected.

PREHEAT - Displays temperature of oven during preheat mode. Also displays internal temperature of meat when probe is in use (HGS25 models).

PROBE INDICATOR (HGS25 models) - Indicates the probe is installed in oven. The internal temperature of the meat is displayed in place of the preheat temperature.

START - Touch pad to complete an entry.

TEMPERATURE - Touch pad to select cooking temperature.

TIME - Touch pad to set time of day and/or timer.

TIMER – There are two timers- TIMER 1 AND TIMER 2; Each counts down the time in hours and minutes. With less than 60 minutes remaining, the timer also displays seconds.

WARMING DRAWER INDICATOR (HGS24 and HGS25 models)- Icon displays when warming drawer is in use. Indicates warming drawer setting.

Other Indicators and Features

BEEP - Signals that more information must be entered or confirms the receipt of an entry. A beep also signals the end of a program or an oven error.

DEFAULT SETTINGS - The cooking modes automatically select the default temperature. These can be changed when a different one is needed.

FLASHING SYMBOL OR NUMBER - Signals an incomplete setting and calls for another step or START to be touched.

F NUMBER CODES - These codes are displayed if there is a problem with the range.

CONVECTION FAN - The convection fan operates during any convection mode. When the oven is operating in the convection mode, the fan will turn off automatically when the door is opened except when in the dehydrate mode. The convection fan will also run during the preheat time for specific modes and during the self-clean mode.

Setting Up Your Range

Setting the Clock (after power to the range has been off)

- Always set the clock after installation or after a power failure. Once power returns to the oven, the clock defaults to 12:00 am.
- The time of day is displayed in hours and minutes.
- The clock time will appear during all oven operations except when the timer or a timed cooking operation is running.
- The oven is preset to a 12-hour clock and indicates AM or PM.

Note: To switch to a 24 hr. clock, see the "Select Function" section, page 7.

1. **CLOCK** will be displayed and the hour digits will flash.

Turn knob to select hour and AM or PM. Turning to the right increases by 1 hour increments; turning to the left decreases by 1 hour increments.

2. **Touch TIME.** **CLOCK** will still be displayed and the minute digits will flash.

3. **Turn knob.** Set minutes.

4. **Touch TIME** and the clock is now set.



Changing the Clock Time

1. **Touch Time.** **TIMER 1** will flash in display.
2. **Turn knob** to select **CLOCK**.
3. **Touch TIME** again and hour digits will flash.
4. **Turn knob** to change hours.
5. **Touch TIME** again and minute digits will flash.
6. **Turn knob** clockwise or counter-clockwise to change minutes.
7. **Touch TIME** again and the clock is set.

BEEP REMINDER

If operation is not completed, the oven will beep periodically as a reminder to set clock time. Push **OFF**.

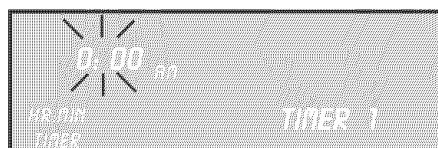

Helpful Hint

To cancel the **TIME** selection when setting the clock, touch **OFF** at any time while in the clock mode.

Setting Up Your Range

SELECT FUNCTIONS is the section of the menu where you can set or change the following features on your range:



VOLUME (decrease or increase loudness of control beeps)



TEMPERATURE FORMAT (switch temperature scale to Fahrenheit or Celsius)



TIME FORMAT (12 hr or 24 hr)



LOCKKEYS (oven control pad lockout)



LANGUAGE OPTION (for display; select English, Spanish, or French)



CLOCK DISPLAY (yes or no)



OVEN TEMPERATURE OFFSET (used to calibrate the oven temperature)



DEMO MODE (used by appliance stores)



RESET DEFAULTS (change *all* function settings back to original factory settings)



SABBATH FEATURE (for religious faiths with "no work" requirements on the Sabbath)

NOTE: In the event of a power failure, the functions return to the factory settings and will need to be reset.

Accessing and Using the Select Functions Menu

To access the SELECT FUNCTIONS menu, **touch and hold COOKING MODE** pad for five (5) seconds.

SELECT FUNCTION is displayed.

1. **Turn knob** to desired feature.
2. **Press START** to choose any function, and turn knob to choose any sub-functions.
3. After selecting feature(s), **touch OFF** to save settings.

TIPS on Using Functions

- There will be a slight delay before each message (or feature) can be seen in the display.
- Turn knob slowly, and wait approximately one second for display to show next feature.
- To move through the feature menu, slowly turn the knob clockwise one click after each feature appears.

BEEPS

To indicate when a mode is done, 3 consecutive beeps will sound.

Setting Up Your Range



BEEP VOLUME

- The volume of the control beep can be changed from **LOW** (softest) to **HIGH** (loudest).
- The control default for beep volume is **Medium**.

Changing the beep volume

1. **Access SELECT FUNCTION** Menu.
2. **Turn knob** clockwise slowly until **VOLUME** is displayed.
3. **Touch START.**
4. **Turn knob** to select volume level Low, Medium or High.
5. **Touch START.**



CHANGE TEMPERATURE

- The oven has been preset to the Fahrenheit temperature scale.
- The feature allows you to switch between Fahrenheit and Celsius temperature.

Changing the Temperature Scale

1. **Access SELECT FUNCTION** Menu.
2. **Turn knob** clockwise slowly until **SELECT TEMP F-C** is displayed.
3. **Touch START.**
4. **Turn knob** to select Fahrenheit (F) or Celsius (C).
5. **Touch START** to accept new selection.



TIME FORMAT

- The clock can be set to a 12-hr or 24-hr format.
- The default for clock format is 12-hr.

Changing the TIME FORMAT

1. **Access SELECT FUNCTION** Menu.
2. **Turn knob** clockwise slowly until **TIME FORMAT** is displayed.
3. **Touch START.**
4. **Turn knob** to select 12 hr or 24 hr format.
5. **Touch START** to accept new selection.



LOCK KEYS

- The keypad can be locked for safety purposes.
- This feature can be used to prevent changes to the oven function.

Locking or Unlocking the Oven Control Panel

1. **Access SELECT FUNCTION** Menu.
2. **Turn knob** clockwise slowly until **LOCK KEYS** is flashing.
3. **Touch START. KEY PAD LOCKED** is displayed. The display will beep if a key is pressed to indicate that the keypad is locked.
4. **To unlock** keypads, touch **COOKING MODE** and hold for 5 seconds. Display will read **UNLOCKING PAD.**
5. When unlocked, the clock will again appear in the display.

Note: This function **DOES NOT** lock the oven door.

ABC LANGUAGE DISPLAY

- Language choices are English, Spanish, and French.
- English is the default language.

Changing the Language Display

1. **Access SELECT FUNCTION** Menu.
2. **Turn knob** clockwise slowly until **LANGUAGE OPTION** is displayed.
3. **Touch START.**
4. **Turn knob** clockwise to select language.
5. **Touch START** to accept a language change.

NOTE

The **SELECT FUNCTION** menu is displayed in English only, regardless of language selected.

Setting Up Your Range



CLOCK DISPLAY (ON or OFF)

- Clock time display can be turned off.
- The default display is on.

Turning the Clock Display ON or OFF

1. Access **SELECT FUNCTION** Menu.
2. Turn knob clockwise slowly until **CLOCK DISPLAY** is displayed.
3. Touch **START**.
4. Turn knob once and **ON** or **OFF** will appear in display.
5. Touch **START** to accept new selection.



OVEN TEMPERATURE OFFSET

- Allows the adjustment of the oven temperature if food is consistently too brown or too light.

Changing the Oven Temp Offset

1. Access **SELECT FUNCTION** Menu.
2. Turn knob clockwise slowly until **OVEN TEMP OFFSET** is displayed.
3. Touch **START**. 0° F is displayed.
4. Turn the knob to the right to increase temperature +25°F and to the left to decrease -25° temperature.
5. Touch **START** to accept a temperature change.

DEMO DEMO MODE

The demo mode is for appliance store use only.



RESET DEFAULTS

- This feature is used to change all the "Select Functions" settings back to the original factory settings (or defaults).

Resetting the factory settings.

1. Access **SELECT FUNCTIONS** Menu.
2. Turn knob clockwise slowly until **RESET DEFAULTS** is displayed.
3. Touch **START**. Display reads **SELECT FUNCTION**.



SABBATH FEATURE

- The oven will bake for 48 hours before automatically turning off.
- Oven or warming drawer cannot be operating to set the Sabbath Feature.

Setting the Sabbath Feature

1. Access **SELECT FUNCTIONS** Menu.
2. Turn knob clockwise until **SABBATH OPTION** appears.
3. Touch **START**. **BAKE** will show in display and temperature will flash.
4. Turn knob to set oven temperature.
5. Turn oven light on if desired (touch **LIGHT**).
Note: The light cannot be changed after this point. It will stay on or off, as selected, during the entire Sabbath mode.
6. Touch **START**. Oven starts after 5 seconds.
Note: The probe **CANNOT** be used during the Sabbath mode.

While baking in Sabbath mode, the display will show **SABBATH** and the **BAKE** icon will be displayed. The clock will be off and no temperature will show in the display.

During the Sabbath mode, only the off key will operate. **Press OFF at any time during the Sabbath mode to end the mode and turn off the oven.**

At end of 73 hours, the oven will turn **OFF** automatically and the display will show **SABBATH END**. Touch **OFF** to return to time of day.

Cooktop Features

Before Using the Cooktop

- Remove all packing materials and labels from the cooktop surface.
- While cool, wipe with a clean, damp sponge and dry.
- Optimum cooking results depend on the proper cookware use.
- Read and understand all safety precautions and Use and Care Manual information prior to operating.

Sealed Gas Burners

Your new cooktop has sealed gas burners and removable burner caps. There are no burner parts under the cooktop to clean, disassemble or adjust. Your cooktop has four (4) different burner cap sizes. Match the pan size to the burner size.

WARNING: To prevent flare-ups do not use the cooktop without all burner caps and all burner grates properly positioned.

Burner Output by Fuel Type (BTU/hr)

	Left Front	Left Rear	Right Front	Right Rear
Natural Gas	9100	12500	15000	5500
Propane	7500	11000	15000	5000

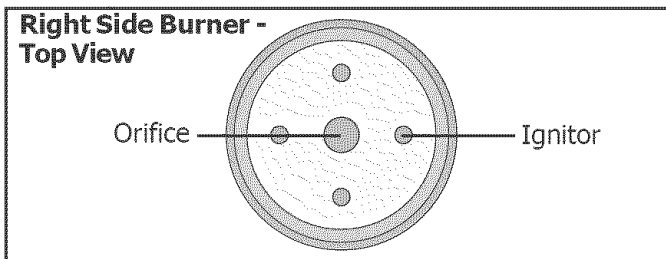
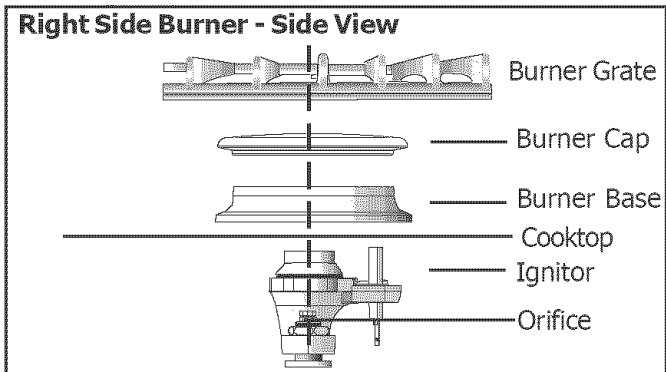

Burner Caps

The burner cap is porcelainized steel. Make sure the burner cap is completely seated into the burner base before attempting to light the burner. If the burner cap is not placed correctly, the burner may not light or the flame may not burn completely or correctly.

Burner Grates

Your cooktop has two grates: one for the left side of the cooktop and one for the right side of the cooktop. Position them as shown in the figure below. Do not operate the burner without a pan on the grate.

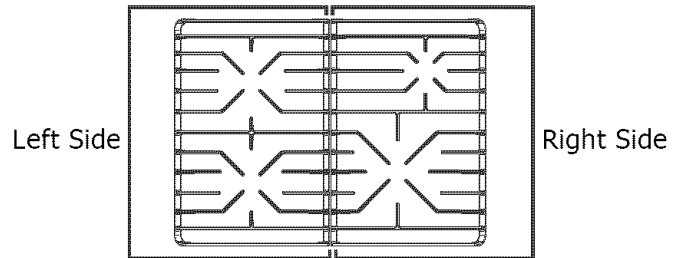

WARNING: All burner grates and burner caps must be properly positioned on the cooktop whenever the cooktop is in use. Each of the feet on the grates must be placed into the corresponding dimples in the cooktop. Do not use a grate if the rubber feet are missing or damaged.

Cooking Chart

Use this chart as a guide for heat settings:

Uses	Heat Settings
Bringing water to a boil	High
Pan frying, sauteing, browning meat, deep fat frying	Medium High
Most frying, eggs, pancakes, slow boil	Medium
Finish cooking covered foods, steaming	Medium Low
Melting butter and chocolate	Low
Tomato sauces, soups, stews, keeping foods warm	Sim (Simmer)

A range of heat settings are listed because the actual setting depends on:

- 1) size, type and quality of pan (See "Cookware Selection Guide", page 27).
- 2) type, quantity and temperature of the food
- 3) burner used
- 4) the cook's preference.

CAUTION: To prevent possible damage to the pan or range, the flame should not extend beyond the edge of the pan.

Cooktop Operation

Burner Control Knobs

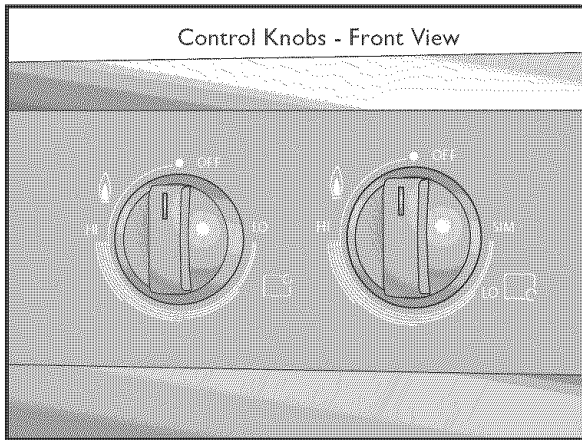

The burner controls have an infinite number of heat settings with no fixed positions.

To LIGHT: Select the appropriate control knob, push in and turn counterclockwise to the flame symbol. The ignitor will click.

To SET FLAME SIZE: After lighting, turn counterclockwise to the desired flame size.

Turn OFF by turning the control knob clockwise to OFF.

A plastic bezel is located under each control knob.

To remove knob, spring and bezel: Place knob in the OFF position. Pull straight out and off. Spring and bezel will be loose and can be pulled straight off after the knob is removed.

To replace knob, spring and bezel: Place spring and knob on top of bezel being careful to line up center holes. Push down on knob so that spring is tense. With knob in off position, place center hole around shaft on range and push bezel, spring and knob in toward range. Release knob.

Electronic Ignition

The cooktop uses electronic igniters to light the burners. There is no pilot light. Each burner has its own igniter. For best results, center the pan over the burner before ignition.

The ignitor should be clean and dry for proper operation.

- Avoid getting water or food on the igniter.
- If the igniter is wet or soiled, it may spark without igniting the burner.

Note: If the burner does not light within 4 seconds, turn the burner off. Check to see that the cap is positioned correctly on the burner base and the igniter is clean and dry. If a burner still fails to ignite, see *Self Help - Cooktop*, page 29.

Typical Flame Characteristics

For natural gas use, the burner flame should be blue in color and stable with no yellow tips, excessive noise or fluttering. It should burn completely around the burner cap. For Propane (LP) use, some yellow tips are normal. See Installation Instructions for further explanation.

Foreign particles in the gas line may cause an orange flame during initial use. This should disappear with use. Check burner cap to make sure port holes are not obstructed. If the ports are clogged, see *Cleaning the Cooktop*, page 23.

Note: An audible "pop" may be heard when the burner is turned off manually. The "popping" may be louder with LP gas than with natural gas. This is normal.

Refer to the Cooking Guide (previous page) for flame settings.

Power Failure

In the event of a power failure, the cooktop burners can be ignited manually. Hold a match at the ports and turn the control knob to the HI position. Wait until the flame is burning all the way around the burner before adjusting the flame to the desired height. **DO NOT attempt to light the broil burner or bake burner manually.**



CAUTION: All igniters spark when any single burner is turned ON. Do not touch any of the burners when the cooktop is in use.

Burner Performance

For best cooking results, observe the following burner characteristics:

PowerSim™ Burner (Right Front) (HGS25 models): The PowerSim™ burner is the most versatile of the burners. The cap retains heat longer than normal burner caps. This results in a gentle, more predictable, heat. It can be set low enough to simmer sauces without scorching. However, the flame can also be set high enough to stir-fry and boil quickly. The large size of the burner cap allows the burner to accommodate large pots, so it is also well suited to cooking large quantities of food. When the PowerSim™ burner is engaged, the SIM indicator to the right of the control knob light is lit.

Right Rear: The right rear burner is the smallest burner. It is well suited for delicate cooking such as melting chocolate and butter.

Oven Modes and Features

Oven Racks

Your oven has three racks. HGS25 models are equipped with 2 flat and one telescopic. All others have 3 flat racks. The racks are designed with a stop so they will stop before coming completely out and not tilt.

Caution: To avoid possible burns, place oven racks in desired positions before turning the oven on. Always use oven mitts when the oven is warm.

Removing from oven: Grasp rack firmly on both sides and pull rack toward you. When the stop is reached, tilt rack up and pull the rest of the way out.

Replacing in oven: Grasp rack firmly on both sides. Tilt rack up to allow stop into rack holder. Bring rack to a horizontal position and push the rest of the way in. Rack should be straight and flat, not crooked.

Telescopic Rack (HGS25 models): The telescopic rack allows for easier access to cooking food. To use, grasp entire rack (both sections) of rack and pull straight out until stop is reached. To extend rack, grasp top section and pull straight out. **To remove telescopic rack,** with top section in closed position, grasp entire rack (both sections) firmly on both sides. When the stop is reached, tilt rack up and pull the rest of the way out.

Rack Position (see graphic at right for further details)

RACK 6 (highest position) – Use for melting cheese and broiling thin foods.

RACK 5 – Use for broiling most meats and toasting bread.

RACK 4 – Use for broiling thicker meats.

RACK 3 – Use for most baked goods when baking on one rack, such as on a cookie sheet or baking pan, cakes, frozen convenience foods, biscuits, brownies, muffins.

RACK 2 – Used for pies, casseroles, breads, bundt or pound cakes, small roasts or poultry.

RACK 1 (lowest position) – Use for angel food cake, large roasts, turkey.

Multiple Rack Cooking:

When using multiple racks, follow the placement recommendations below.

Two rack: For cakes, use rack positions 2 and 5.

Three rack: (for convection bake): Use positions 1, 3 and 6.

Pan Placement

Baking results are better if pans are placed in the center of the oven. If baking more than one pan on a rack, allow at least 1" to 1 1/2" of air space around the pan. When baking four cake layers at the same time, stagger pans on two racks so that one pan is not directly above the other. To allow for best baking results, place cakes on back of upper rack and front of lower rack (see graphic at right).

Preheating

Preheat the oven if the recipe recommends it.

Preheating is necessary for good results when baking cakes, cookies, pastry and breads. When using the probe preheating is not recommended. Setting a higher temperature does not shorten preheat time. Place oven racks in proper position before preheating. A beep will confirm that the oven is preheated and the selected oven temperature will be displayed.

Baking Pans

Glass baking dishes absorb heat, therefore, reduce oven temperature 25° F when baking in glass.

Shiny, smooth metal reflects heat resulting in lighter, more delicate browning.

Dark, rough or dull pans will absorb heat resulting in browner, crisper crust. Some manufacturers recommended reducing temperature 25° F when using this type of pan. Follow manufacturer recommendations. Use dark pan for pies.

Insulated baking pans may increase the length of the recommended baking time.

Power Failure

DO NOT attempt to light the broil burner or bake burner manually. Only the cooktop burners can be lit manually.

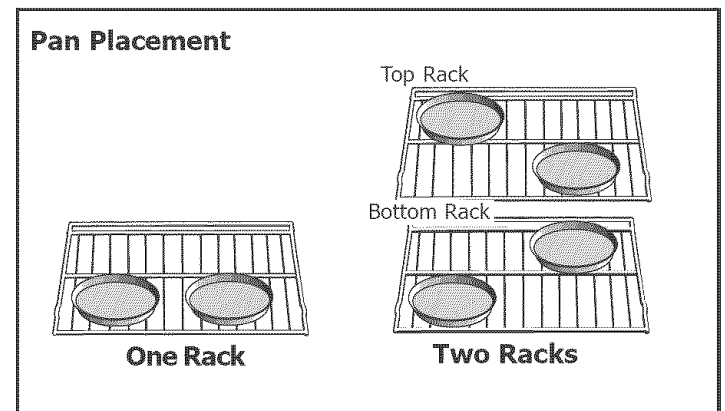
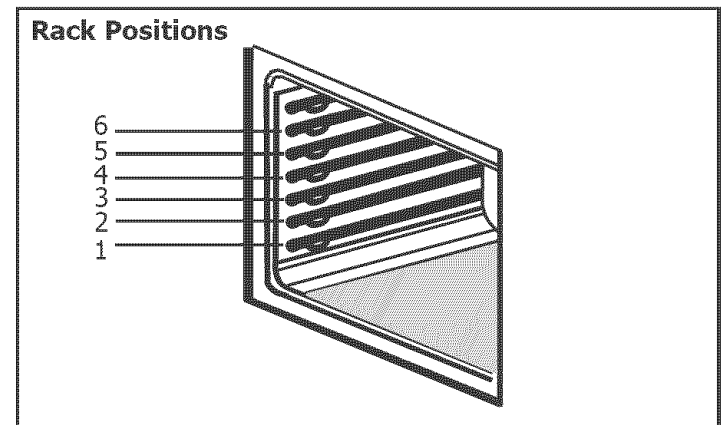

Oven Modes - Bake and Convection Bake

BAKE, PROOF (HGS25 models) and WARM

Baking is cooking with dry, heated air. The lower burner cycles to maintain the oven temperature:

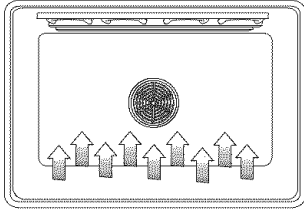

The Bake mode can be used to prepare a variety of food items, from pastries to casseroles. It can also be used to roast meats.

In the **Warming** mode, the oven uses the lower element to maintain a low temperature to keep food at serving temperature.

- Use the Warming setting on the oven to keep foods hot until ready to serve.
- The Warming mode temperatures are 140° - 220° F. The default temperature is 170° F.
- Foods that need to be kept moist should be covered with a lid or aluminum foil.

In the **Proofing** mode, the oven will use the lower burner to maintain a low temperature to proof bread. Proofing is the rising of a yeast dough.

- The Proofing mode temperatures are 85° to 110° F. The default temperature is 100° F.
- Loosely cover the bowl or pan and use any rack that accommodates the size of the container.
- **Keep the door closed** and use the oven light to check the rising of the dough.

*The convection bake temperature is 25°F less than recommended on packages or recipes. The temperature in this chart has been reduced 25°F.

**This chart is a guide. Actual times depend on the mixes or recipes baked. Follow recipe or package directions and reduce temperature appropriately.

CONVECTION BAKE

Convection Baking is similar to Baking. In this case, heat comes from the lower element. The main difference in convection baking is that the heat is circulated throughout the oven by the convection fan:

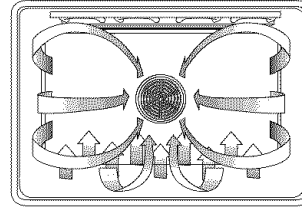

The Convection Bake mode is well-suited for baking large quantities of food on multiple racks. It can be used to prepare cookies, pies, cupcakes, pastries, breads, snack foods and appetizers among other items.

The benefits of Convection Baking include:

- Slight decrease in cooking time
- Three rack cooking (more even browning)
- Higher Volume (yeast items rise higher)
- Cook more items at once

For Best Results:

- Reduce recipe temperature by 25° F. Refer to the Convection Baking chart for examples.
- Place food in low-sided, uncovered pans such as cookie sheets without sides.
- Center baking pans side to side on the oven rack.

Convection Bake Chart

Food Item	Rack Position	Temp.* (preheated oven) (F°)	Convection Bake Time** (min)
Cake			
Cupcakes	3	325	18 - 21
Bundt Cake	2	325	37 - 43
Angel Food	1	325	39 - 43
Pie			
2 crust, fresh, 9"	2	350 - 400	45 - 55
2 crust, frozen fruit, 9"	2	350	68 - 78
Cookies			
Sugar	3	325 - 350	6 - 11
Chocolate Chip	3	325 - 350	10 - 15
Brownies	3	325	29 - 36
Breads			
Yeast bread, loaf, 9x5	2	350	20 - 24
Yeast rolls	3	350 - 375	14 - 18
Quick Bread, loaf, 8x4	2	325 - 350	45 - 55
Biscuits	3	350 - 375	11 - 15
Muffins	3	400	16 - 20
Pizza			
Frozen	3	375 - 425	23 - 26
Fresh	3	400 - 425	12 - 15

Oven Modes - Broil

BROIL

Broiling uses intense heat radiated from the broil burner:

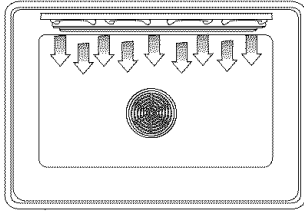

The Broil mode is best suited to cooking thin, tender cuts of meat (1" or less), poultry and fish. It can also be used to brown breads and casseroles.

The benefits of Broiling include:

- Fast and efficient cooking
- Cooking without the addition of fats or liquids
- Browning as the food cooks

For Best Results:

- Preheat oven 3-4 minutes
- Steaks and Chops should be at least 3/4" thick
- Brush fish and poultry with butter or oil to prevent sticking
- Use the broil pan and grid included with your range
- Do not cover the broiler grid with foil. It is designed to drain fats and oils away from the cooking surface to prevent smoking and spattering
- Turn meats once halfway through the recommended cooking time (see Broil Chart for examples).
- When top broiling casseroles, use only metal or glass ceramic dishes such as Corningware®.
- Never use heat-proof glass (Pyrex®); it cannot tolerate the high temperature.

ALWAYS BROIL WITH THE DOOR CLOSED

Broil Chart

Food and Thickness	Rack Position	Broil Setting	Internal Temp. (°F)	Time Side 1 (min)*	Time Side 2 (min)*
Beef					
Steak (3/4" - 1")					
Medium Rare	5	High*	145	6-7	5-6
Medium	5	High	160	7-8	6-7
Well	5	High	170	8-9	7-9
Hamburgers (3/4"-1")					
Well	4	High	160	9-11	8-10
Poultry					
Breast (bone-in)	4	Low*	170	18-20	18-19
Pork					
Pork Chops (1")	4	High	160	8-9	7-8
Sausage - fresh	3	High	160	7-9	6-8
Ham Slice (1/2")	5	High	160	3-4	2-3
Seafood					
Fish Filets, 1" Buttered	4	Low	Cook until opaque & flakes easily with fork	6-7	DO NOT TURN
Bread					
Garlic Bread, 1" slices	5	High		2-4	

Broiling times are approximate and may vary slightly.
Times are based on cooking with a preheated broil element.

Oven Modes - Convection Roast



CONVECTION ROAST

Convection Roast uses heat from the bottom burner as well as heat circulated by the convection fan:

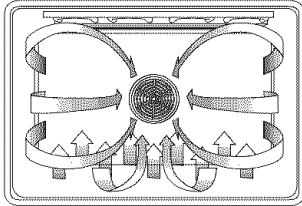

The Convection Roast mode is well suited to preparing tender cuts of meat and poultry.

The benefits of Convection Roasting, include:

- As much as 25% faster cooking than standard Roasting/Baking
- Rich, golden browning

For Best Results:

- Use the same temperature as indicated in the recipe.
- Check doneness early as roasting time may decrease by as much as 25%. Refer to Convection Roast Chart for examples.
- Do not cover meat or use cooking bags.
- Use the broil pan and grid provided with the range for roasting. A low-sided, uncovered pan can also be used.
- Use the probe or a meat thermometer to determine the internal temperature of the meat.
- If the meat is browned to your liking, but is not yet done, a small strip of foil can be placed over the browned area to prevent overbrowning.
- Let meat stand covered with foil 10-15 minutes after removing from the oven.

Convection Roast Chart

Meats	Weight (lb)	Oven Temp. (°F)	Roasting Time* (min per lb)	Internal Temp. (°F)
Beef				
Rib Roast	4 - 6	325	25-32 28-32	145 (med/rare) 160 (medium)
Rib Eye Roast, (boneless)	4 - 6	325	24-32 27-32	145 (med/rare) 160 (medium)
Rump, Eye, Tip, sirloin (boneless)	3 - 6	325	25-30 28-32	145 (med/rare) 160 (medium)
Tenderloin Roast	2 - 3	425	15-25	145 (med/rare)
Pork				
Loin Roast (boneless or bone-in)	5 - 8	350	15-25	160
Shoulder	3 - 6	350	20-30	160
Poultry				
Chicken - whole	3 - 4	375	14-20	180
Turkey, unstuffed**	12-15	325	10-14	180
Turkey, unstuffed**	16-20	325	9-13	180
Turkey, unstuffed**	21-25	325	6-10	180
Turkey Breast	3 - 8	325	20-25	170
Cornish Hen	1 - 1 ½	350	45-75 (total time)	180

*Roasting times are approximate and may vary depending on the shape of the meat.

**Stuffed turkey requires additional roasting time. The minimum safe temperature for stuffing in poultry is 165°F.

Oven Modes - Dehydrate (HGS24 and HGS25 models only)



DEHYDRATE

Dehydrate dries with heat from lower burner. The heat is circulated throughout the oven by the convection fan.

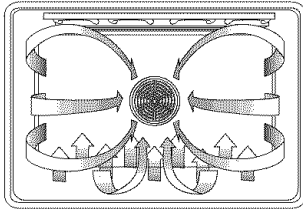

Dehydrating is used to dry and/or preserve foods such as fruits, vegetables and herbs. This mode holds an optimum low temperature (100° F - 160° F) while circulating the heated air to slowly remove moisture.

For Best Results:

- Dry most fruits and vegetables at 140° F. Dry herbs at 100° F. (Refer to the Dehydrate Chart for examples).
- Drying times vary depending on the moisture and sugar content of the food, the size of the pieces, the amount being dried and the humidity in the air. Check food at the minimum drying time.
- Multiple racks can be used simultaneously. Contact your Bosch dealer for drying racks.
- Treat fruits with antioxidants to avoid discoloration.
- Consult a food preservation book, county Cooperative Extension Office or library for additional information.

The door must be open during the Dehydrate mode. Prop the door open at least 1" by placing an object (i.e.; wooden spoon) in the upper corner between the door and the side panel. Be careful that the object does not touch the oven gasket.

Dehydrate Chart

Food	Preparation	Approximate Drying Time*(hrs)	Test for Doneness
Fruit			
Apples	Dipped in ¼ cup lemon juice and 2 cups water; ¼" slices	11-15	Slightly pliable
Bananas	Dipped in ¼ cup lemon juice and 2 cups water, ¼" slices	10-15	Soft, pliable
Cherries	Wash and towel dry. For fresh cherries, remove pits	10-15	Pliable, leathery, chewy
Orange Peels and slices	¼" slices of orange; orange part of skin thinly peeled from oranges	Peels: 2-4 Slices: 12-16	Orange peel: dry and brittle. Orange slices: skins are dry and brittle, fruit is slightly moist
Pineapple rings	Towel dried	Canned: 9-13 Fresh: 8-12	Soft and pliable
Strawberries	Wash and towel dry. Sliced ½" thick, skin (outside) down on rack	12-17	Dry, brittle
Vegetables			
Peppers	Wash and towel dry. Remove membrane of peppers, coarsely chopped about 1" pieces	16-20	Leathery with no moisture inside
Mushrooms	Wash and towel dry. Cut off stem end. Cut into 1/8" slices	7-12	Tough and leathery, dry
Tomatoes	Wash and towel dry. Cut thin slices, 1/8" thick, drain well.	16-23	Dry, brick red color
Herbs			
Oregano, sage parsley and thyme, and fennel	Rinse and dry with paper towel	Dry at 100°F 3-5 hrs	Crisp and brittle
Basil	Use basil leaves 3 to 4 inches from top. Spray with water, shake off moisture and pat dry	Dry at 100°F 3-5 hrs	Crisp and brittle

* Oven will stay on for 48 hours before shutting off automatically

Selecting the Oven Mode

Setting the Cooking Mode

1. **Touch COOKING MODE.**
2. **BAKE** will flash in the display.
If no further setting is made within 5 seconds, control will beep and flash. If this occurs, **press START**.
3. To change the cooking mode, **turn knob**.
4. **Push START.**
The selected mode will appear in the display, along with the default temperature for that mode, which will be blinking.
5. To select a different temperature, **turn knob** to the right or left (in 5° increments) to desired temperature.
6. **Touch START.** If **START** is not touched, oven will automatically turn on in 5 seconds.
7. The display alternates between the cooking mode and preheat.
The preheated temperature is also displayed, starting at 100°F. The actual temperature increases until set temperature is reached, at which point the **oven will beep**.
8. To change temperature during cooking, **touch Temperature.** **Turn the knob** to select new Temperature and **press START**.
9. Once cooking has been completed, **touch OFF** to turn off oven.

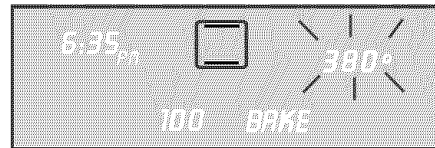

HELPFUL TIP

To back out of a current mode, push **OFF**.

Selecting **OFF** when not in a mode menu will stop oven function.

Note: After the oven has been turned off, **HOT** appears in the display where the cooking mode was. This is to indicate that the oven is off but still hot. When the oven temperature drops below 176° F, **HOT** is no longer seen in the display.

Oven Operation Time

The oven will automatically shut off after 12 hours (24 hours if the time format is set for 24 hour in the **SELECT FUNCTION** section).

Oven Vent

The oven vent is located above the cooktop directly below the display.

It is normal to see steam escaping from the vent and condensation may collect on the backguard and cooktop.

This area may become hot when the oven is in use.

Do not block the vent as it is important for air circulation.

Using the Timer/s

Setting the Timer/s

1. Touch **TIME** and **TIMER 1** will be displayed.

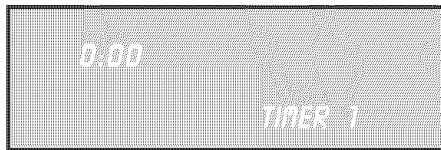

2. Turn **counterclockwise** and **TIMER 2** will be displayed. Select **TIMER 1** or **2**, then push **TIME**. **SET TIMER 1 (2)** appears in display. Minutes flash.

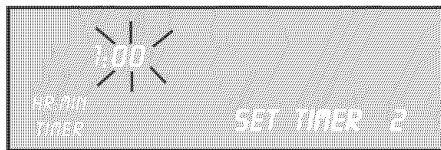

3. Turn **knob to the right** to increase by 1 minute increments or left to decrease by 1 minute increments. Continue to **turn knob** until desired minutes are displayed.

If setting only minutes, **press START**. Otherwise, continue to **step 4**.

4. Touch **TIME** again and the hours will flash.

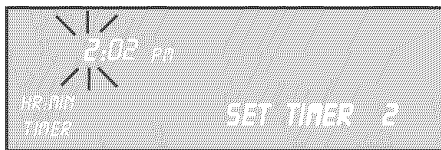

5. Turn **knob to the right** to increase by 1 hour increments or left to decrease by 1 hour increments until desired hours are displayed.
6. Touch **TIME** again. The **TIMER** is now set. If **TIME** or **START** is not touched, display will beep and timer will flash.

Changing the Timer/s

1. Touch **Time**. **TIMER 1** will appear in display. Select either **TIMER 1** or **2**.

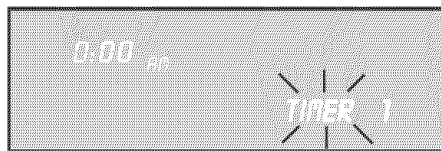

2. Push **TIME**. **RESET TIMER 1 (2)** appears in the display. Minute digits flash.
3. Turn **knob** clockwise or counter-clockwise to change minutes.
4. Touch **TIME** again and hour digits will flash.
5. Turn **knob** clockwise or counter-clockwise to change hours.
6. Touch **TIME** and new time is set.

Clearing the Timer/s

1. Touch **TIME** once. **TIMER 1** flashes.
2. Turn **knob** to select **CLEAR TIMER 1(2)**.
3. Touch **TIME**.
4. If **TIME** pad is not touched, range will beep and display will continue flashing.

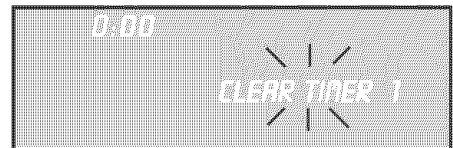

When the specified time has elapsed, the control beeps. **TIMER 1 (2) END** flashes in the display.

1. Touch **TIME** to return to main screen.

TIP

Turn the knob to display the time of day or further information about the oven mode when the timers are in use.

CANCELLING

If operation is not completed, the oven will beep periodically as a reminder to set time. Push **OFF** to exit the **TIMER** mode.

Selecting **OFF** when not in a setting mode will stop oven function.

Using Timed Cook

The **TIMED COOK** feature sets the oven to a cooking mode for a set period of time and then turns it off. The **TIMED COOK** feature is available for each of the following oven modes: Bake, Convection Bake and Convection Roast.

Be sure that the time-of-day clock displays the correct time before beginning. See "Changing the Clock Time" to adjust the time.

Setting a Timed Mode

1. **Touch COOKING MODE.**
2. **BAKE** will be displayed. To select a different cooking mode, turn the knob.
3. **Touch START.**
4. **Turn knob** to select desired temperature.
5. **Touch TIME.** **TIMED BAKE** appears in the display.
6. **Touch TIME.** **SET BAKE TIME** appears in the display and minutes flash. **Set minutes.** **Touch TIME.**
7. Hours Flash. **Set hours.** **Touch START.**

Note: time required for the oven to reach temperature must be included in the set cooking time.

8. **TIMED BAKE** appears in display and the oven begins to preheat.

After cooking is complete, display flashes **TIME COOK END** and **reminder beeps will sound.**

Delaying the Start of a Timed Mode

1. Follow steps **1** through **5** above.
2. **Turn knob** until **DELAYED BAKE** appears in display.
3. **Touch Time.** **SET BAKE TIME** appears in the display and minutes flash. **Set minutes.** **Touch TIME.**
4. Hours Flash. **Set hours.** **Touch TIME.**
5. **SET BAKE END** appears in the display. **Touch TIME.**
6. Use knob to **enter the time of day the oven will stop cooking or turn off:**
Set hours. **Touch TIME.**
Set minutes. **Touch TIME.**

The clock automatically calculates the time of day at which the cooking mode starts and stops. The displayed cooking time counts down by the minute.

7. At the end of the programmed cooking time, the oven will automatically turn off. Display will show **TIME COOK END** and the oven will beep.

Note: Remove food from oven immediately after cycle has finished to prevent overcooking. Food left in the oven will continue to cook even after the cycle is complete.

To check the cooking time and stop time after a delay has been set, **touch TIME.** **Turn knob to BAKE END or BAKE TIME.** **Touch TIME.**

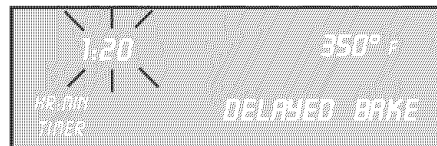

NOTE

At the end of the programmed cooking time, the oven will automatically turn off. The Display will show the mode and **END.**

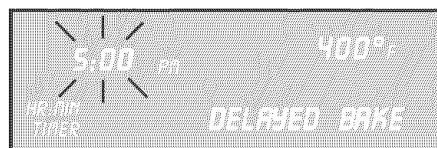

NOTE

Delayed cooking is **not recommended** for foods that need to rise (i.e., cookies, cakes, breads, souffles, etc.)

Using the Probe (HGS25 models)

- The probe can be used to determine the internal doneness or the "END" temperature of many foods, especially meats and poultry.
- The temperature range for the probe is 135°F to 200°F (57°C to 93°C).
- Preheating the oven is not recommended when using the probe. A hot oven will impair your ability to easily connect the probe to the receptacle and to insert it into the meat.
- Oven temperature can be set for 100°F up to 450°F (38°C up to 232°C).
- **To change only the oven temperature, touch TEMPERATURE. OVEN TEMP** will flash in the display. **Turn the knob** to desired temperature and **press START** twice.
- **To change the probe temperature, touch TEMPERATURE.** The oven temperature will flash. **Press START** and the **PROBETEMP** will flash. **Turn the knob** to desired temperature and **press START** again.

INSERTING THE PROBE

Insert the probe tip into the food item.

- For meats, insert the probe tip into the thickest part and do not touch bone, fat, or gristle.
- For large poultry products and turkeys, insert the probe in the thickest part of the inner thigh.
- For other foods, such as a meatloaf, the probe tip should be located in the center of the thickest part of the food.

USING THE PROBE

1. Prepare meat and place in roasting pan (or on rack in roasting pan as recipe specifies). Insert the probe into the meat (See "Inserting the Probe", above).
2. Make sure the probe is not touching gristle, fat, bone, the roast rack or the pan.
3. Place roasting pan with meat in cold oven on recommended oven rack. **Plug probe into the probe receptacle.** The probe symbol will appear in display.

Note: The probe temperature can only be set when the probe is installed in the oven.

4. **Touch COOKING MODE** and **select BAKE, CONVECTION BAKE or CONVECTION ROAST.** The default oven temperature will appear.
 5. **Turn knob** to change temperature if necessary.
 6. **Touch START.**
 7. **Turn knob** to set the probe temperature (desired end temperature of the food).
 8. **Touch START.**
- The chosen oven temperature and mode are displayed to the right of the time.
 - The probe temperature is displayed in the center to the left of the cooking mode. It increases in 5°F increments until the chosen temperature is reached.
 - The oven is preheated when the beep signals once.
 - When the set probe temperature is reached, **END** appears in display and oven turns off. **Touch OFF** to clear display.
 - If probe is removed before touching **OFF, REINSERT PROBE** is displayed. If this happens, **touch OFF.**

PROBE USE TIPS

- The oven is well insulated and the retained heat will continue to cook the meat after the oven has shut off. For this reason, remove the meat from the oven as soon as the control beeps.
- Since meat continues to cook after being removed from the oven, set the internal (probe) temperature 5 - 10 degrees below the desired final internal temperature. Allow "standing time" (10 - 20 minutes) before carving the meat.
- Always use the handle of the probe for inserting and removing. Use a potholder to remove since the probe becomes hot.
- Remove the probe from the oven when it is not being used.
- The probe cannot be used with frozen meats. For best results, completely thaw meats before using the probe.

Note: Always remove probe from oven when cooking is complete. The probe symbol will remain in the display until the probe is removed. Do not leave probe attachment in oven during self-clean. Oven will not self-clean with the probe installed in the oven.

The Warming Drawer (HGS24 and HGS25 models)

The warming drawer will keep hot, cooked foods at serving temperature. Always start with hot food. **DO NOT** use to heat cold food other than crisping crackers, chips, and dry cereal, or warming dishes or plates.

Parts Key:

1. Stainless Steel Drawer Interior
2. Gasket
3. Rail Lock

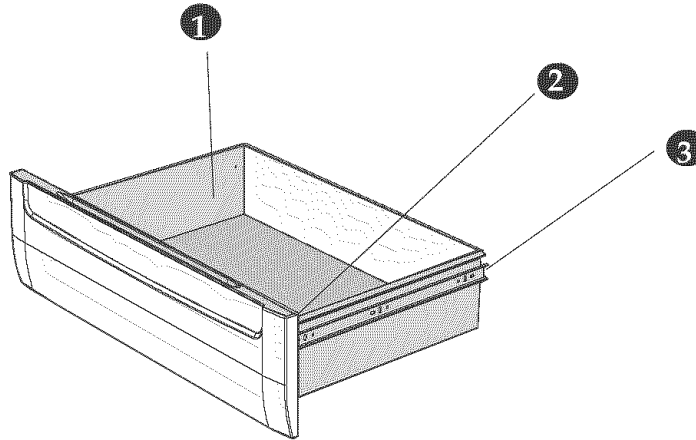

Packaged Inside Drawer:

- Reversible Rack

Usable Space and Utensil Sizes

Drawer Interior:
25"W x 17"D x 5" H

Utensil sizes:

- 2 - 9 x 13" Pyrex 3-quart dishes, side by side.
- 2 - 9 1/2 x 15" Pyrex 4-quart dishes, side by side.
- 4 - 10 1/2" plates, single or stacked
- 3 - 11" plates, single or stacked
- Large 14" pizza, in box.

WARMING
DRAWER
RACK

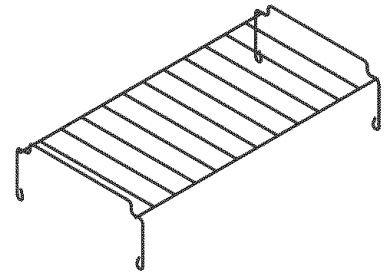

The warming drawer has three settings: Low, Medium and High. The icons below are seen in the display when the corresponding setting is selected:



See the Warming Drawer Chart (next page) for recommended settings.

Using Your Warming Drawer (HGS24 and HGS25 models)

Using Your Warming Drawer

Food should be at serving temperature (above 140° F) before being placed in the warming drawer.

The warming drawer can be used with or without a rack.

- Preheat with rack in place if using that arrangement. It fits side to side.
- Preheat empty serving dish while preheating drawer.
- Add cooked, hot food in cooking utensil or heat-safe serving dishes.
- Food may be kept hot in its cooking container or transferred to a heat-safe serving dish.
- Aluminum foil may be used to cover food.

Warming drawer settings are Low, Medium, and High. Refer to the chart at right for recommended settings. To keep several different foods hot, set the temperature to the food needing the highest setting. Place item needing the highest setting toward the side of the drawer and item needing less heat on the rack or in the center of the drawer bottom.

Setting the Temperature

1. **Touch COOKING MODE.**
2. **Turn knob** to select **WARMING DRAWER.**
3. **Push START.**

Turning Off and/or Cancelling

1. **Press OFF.**
2. **Turn knob** to **CANCEL WARMING DRAWER.**
3. **Press OFF.**

Warming Empty Serving Bowls and Plates

- Use only heat-safe dishes.
- May use reversible rack, in low position to raise utensil from direct contact with bottom of drawer.
- Warm on setting appropriate for utensil.
- Check dish temperature during warming period.
- Place empty plates or dishes in a cold warming drawer. Do not preheat.

Crisping Stale Items

- Place food in low sided dishes or pans.
- Preheat on Low.
- Check crispness after 45 minutes. Add time as needed.

Preheating

- For best results, always preheat warming drawer when warming food.
- Preheat times are as follows:
Low: 10 minutes
Medium: 15 minutes
High: 20 minutes

Warming Drawer Guide

Food	Temp-erature	Covered/ Uncovered
Bacon	Hi	Uncovered
Beef, medium and well done	Med	Covered
Beef, rare	Low	Covered
Bread, Hard Rolls	Med	Uncovered
Bread, Soft Rolls, Coffee Cakes	Med	Covered
Buscuits	Med	Covered
Casseroles	Med	Covered
Eggs	Med	Covered
Fish, Seafood	Med	Covered
Fried Foods	Hi	Uncovered
Gravy, Cream Sauces	Med	Covered
Ham	Med	Covered
Pancakes	Hi	Covered
Pies, One Crust	Med	Covered
Pies, Two Crusts	Med	Uncovered
Pizza	Hi	Covered
Pork	Med	Covered
Potatoes, Baked	Hi	Covered
Potatoes, Mashed	Med	Covered
Poultry, Roasted	Med	Covered
Vegetables	Med	Covered
Plates	Low	Uncovered
Plate of Food	Med	Covered

CAUTION:

Plastic containers or plastic wrap can melt if in direct contact with the drawer or a hot utensil. If it melts onto the drawer, it may not be removable.

DO NOT LINE DRAWER WITH ALUMINUM FOIL.

Cleaning the Cooktop

Daily Cleaning Techniques

The entire range can be safely cleaned by wiping with a soapy sponge, then rinsing and drying.

Note: The cleaners recommended in this manual indicate cleaner types and do not constitute an endorsement of a particular brand. Use all products according to package directions.

CAUTION:

- Before cleaning, be certain the burners are turned off and the grates are cool.
- Always use the mildest cleaner that will do the job. Use clean, soft cloths, sponges or paper towels.
- Rub stainless steel finishes in the direction of the grain. Wipe area dry to avoid water marks.
- Do not clean removable cooktop parts in any self-cleaning oven.
- After cleaning, place all parts in their proper positions before using cooktop.

Cooktop Care Chart

Cooktop Part / Material	Suggested Cleaners	Important Reminders
Burner Base / Aluminum	<ul style="list-style-type: none"> • Detergent and hot water; rinse and dry. • Abrasive cleansers: Brillo[®] or S.O.S.[®] pads. Rinse and dry. 	<ul style="list-style-type: none"> • Clean ports with a stiff nylon bristle toothbrush to clean port openings. • Do not scratch or gouge the port openings. • Do not use a toothpick that may break off.
Burner Cap and exterior finish Porcelain Enamel	<ul style="list-style-type: none"> • Hot sudsy water; rinse and dry thoroughly. • Nonabrasive cleansers: Fantastic[®], Formula 409[®]. • Mild abrasive cleansers: Bon Ami[®], Ajax[®], Comet[®]. • Liquid cleaners: Soft Scrub[®]. • Reassemble. Make sure that the cap is seated on the base. 	<ul style="list-style-type: none"> • Acidic and sugar-laden spills deteriorate the porcelain enamel. Remove soil immediately. • Do not use wet sponge or towel on hot porcelain. • Do not soak burner caps. • Always apply minimal pressure with abrasive cleaners. • Never use oven cleaners, caustic cleaning agents or abrasive cleaning agents on exterior of range.
Control Knobs and Bezels / Plastic	<ul style="list-style-type: none"> • Hot sudsy water; rinse and dry immediately. • To remove knobs, place in off position and pull straight out. 	<ul style="list-style-type: none"> • Do not soak knobs. • Do not force knobs onto valve shaft. • Do not use abrasive scrubbers or cleansers, such as BonAmi[®], Ajax[®], or Comet[®]. They may permanently damage the finish.
Exterior Finish / Stainless Steel	<ul style="list-style-type: none"> • Nonabrasive cleaners: Hot water and detergent, Fantastic[®], Formula 409[®]. Rinse and dry immediately. • Cleaner polish: Stainless Steel Magic[®] to protect the finish from staining and pitting; enhances appearance. • Hard water spots: Household white vinegar. • Mild Abrasive Cleaners: Kleen King[®] stainless steel liquid cleaner, Cameo[®] aluminum & stainless steel cleaner, Bon Ami[®]. • Heat discoloration: Bar Keepers Friend[®]. 	<ul style="list-style-type: none"> • Stainless steel resists most food stains and pit marks providing the surface is kept clean and protected. • Never allow food stains or salt to remain on stainless steel for any length of time. • Rub lightly in the direction of polish lines. • Chlorine or chlorine compounds in some cleaners are corrosive to stainless steel. Check ingredients on label before using.
Grates / Porcelain Enamel on Cast Iron	<ul style="list-style-type: none"> • Nonabrasive cleaners: Hot water and detergent, Fantastic, Formula 409. Rinse and dry immediately. • Mild abrasive cleaners: Bon Ami[®] and Soft Scrub[®]. 	<ul style="list-style-type: none"> • The grates are heavy; use care when lifting. Place on a protected surface. • Blisters / crazing / chips are common due to the extreme temperatures on grate fingers and rapid temperature changes. • Acidic and sugar-laden spills deteriorate the enamel. Remove soil immediately. • Abrasive cleaners, used too vigorously or too often, can eventually mar the enamel.
Igniters / Ceramic	<ul style="list-style-type: none"> • Carefully wipe with a cotton swab dampened with water, ammonia or Formula 409[®]. • Gently scrape soil off with a toothpick. 	<ul style="list-style-type: none"> • Avoid excess water on the igniter. A damp igniter will prevent burner from lighting. • Remove any lint that may remain after cleaning.

Care and Cleaning - Oven



Self Cleaning the Oven

Bosch ovens feature a self-cleaning function that eliminates the manual labor involved with cleaning your oven. During self-cleaning, the oven uses a very high temperature to burn away food soil and grease.

- It is common to see smoke and/or an occasional flame-up during the Self-Clean cycle, depending on the content and amount of soil remaining in the oven. If a flame persists, turn off the oven and allow it to cool before opening the door to wipe up the excessive food soil.
- In a normal Self-Clean mode, the door does not lock at the beginning of the cycle; However, it does lock prior to reaching the high self clean temperatures. The door lock symbol will appear in the display at this point.

The door will not lock at the start of the cycle.

- The oven light does not operate during this mode.
- During Self-Clean, the kitchen should be well ventilated to help eliminate odors associated with Self-Clean. Odors will lessen with use.
- The preset length of cleaning time is 4 hours. The range can also be set to clean for 3 or 5 hours.
- The mode automatically stops at the end of the clean hours.
- When the oven heat returns to a safe temperature after cleaning, the automatic door lock will release and the door can be opened.

Preparing the Oven for Self Clean

1. Remove all utensils and bakeware.
2. Remove oven racks. If oven racks are left in the oven during the self-clean cycle, they will permanently lose the shiny finish and change to a dull dark finish. See Oven Cleaning Chart for proper care.
3. Wipe up any soft soil spills and grease with paper towels. Excess grease will cause flames and smoke inside the oven during self-cleaning.
4. Review illustration below. Some areas of the oven must be cleaned by hand before the cycle begins. Use a soapy sponge or plastic scrubber or a detergent-filled S.O.S.® pad. Hand clean the oven door edge, oven front frame and up to 1-1/2 inches inside the frame with detergent and hot water. Do not clean or rub the gasket on the oven. Rinse all areas thoroughly then dry.
5. Be sure oven light is turned off and the light bulbs and lens covers are in place. **Do not operate oven without lightbulb and cover in place.**

Do not use commercial oven cleaners on the self-clean oven or any part; They will damage the finish or part.



WARNING

To avoid a burn hazard, keep the oven gasket flexible, not hard.

DO hand clean frame area outside gasket

DO NOT hand clean gasket

DO hand clean door area outside gasket

DO hand clean 1-1/2" from rack guides to front of oven cavity.

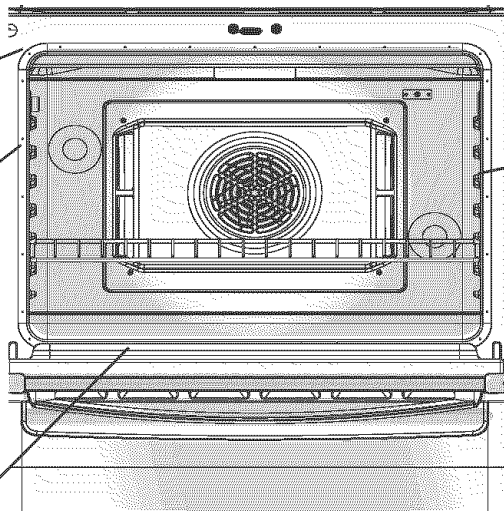

Setting the Self-Clean Mode

1. **Touch COOKING MODE.**
2. **Rotate knob** until **SELF CLEAN** mode appears. **Press START.**
3. The default cleaning time is 4 hours. To change cleaning time, **turn knob** to change number of hours. Otherwise, continue to **step 4.**
4. **Touch START. SELF CLEAN** flashes. **Press START.**
5. **REMOVE RACKS** appears in the display as a reminder to remove oven racks.
6. **Touch START** again to begin the self clean.

Note: In a normal Self-Clean mode, the door does not lock at the beginning of the cycle; however, it does lock prior to reaching the high self clean temperatures. The door lock symbol will appear in the display at this point.

Delaying the Start of the Self-Clean

Note: The time of day must be correctly set for this option to work properly. See section "Setting the Clock" in "Setting Up Your Range", Page 5.

1. **Touch COOKING MODE.**
2. **Rotate knob** until **SELF CLEAN** mode appears. **Press START.**
3. The default cleaning time is 4 hours. To change cleaning time, **turn knob** to change number of hours. Otherwise, continue to **step 4.**
4. **Touch START.**
5. **Rotate knob** until **DELAYED CLEAN** mode appears. **Press START.**
6. **SELF CLEAN END** appears in the display.
7. **Turn knob** to enter the time of day you want the self-clean to end: **Set hours, touch time, set minutes.**
8. **Touch START.** The display will remind you to remove oven racks.
9. **Touch START.** The display shows **DELAYED CLEAN.** The self-clean will automatically start at the appropriate time.

Note: In the **Delayed Self Clean** mode, the door latch is automatically activated at the **beginning of the cycle.** The door lock symbol will appear in the display at this point.

NOTE
The oven lights do not operate in the Self Clean mode.



WARNING

If door does not lock, press **Cancel** and do not self-clean; phone 800/944-2904 for service.

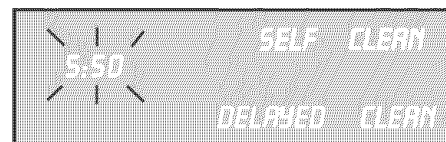
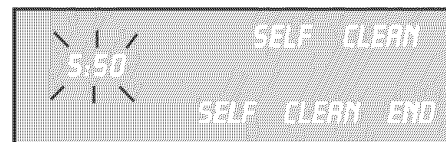
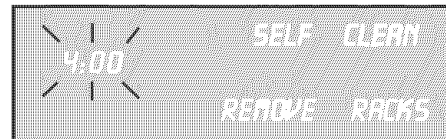
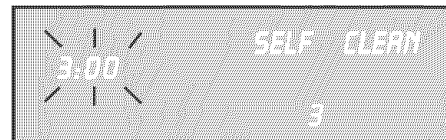

After Self-Cleaning:

1. At the end of the programmed cleaning time, the oven will automatically turn off. **SELF CLEAN END** appears in the display. **Press OFF** to clear.
Note: To cancel or stop while the mode is operating, **touch OFF.** The door will not unlock until the oven reaches a safe temperature.
2. The self-clean mode may produce ash which will settle in the oven. If this happens, remove ash with a damp cloth before using the oven.
3. Wipe rack edges with cooking oil to allow for proper glide. Wipe off excess.
4. After self-cleaning, the entire oven can be safely cleaned with a soapy sponge, rinsed and dried.

Care and Cleaning - Oven

For oven parts and accessories that cannot be self-cleaned, follow the recommended cleaning methods below.

After self-cleaning, the entire oven can be safely cleaned with a soapy sponge, rinsed and dried. If stubborn soil remains, follow the recommended cleaning methods below.

- Always use the mildest cleaner that will remove the soil.
- Rub metal finishes in the direction of the grain.
- Use clean, soft cloths, sponges or paper towels.
- Rinse thoroughly with a minimum of water so it does not drip into door slots.
- Dry to avoid water marks.

The cleaners listed in this manual indicate types of products to use and are not being endorsed. Use all products according to package directions.

PART	CLEANING METHOD
Racks (Oven, Warming Drawer)	Wash with hot sudsy water. Rinse thoroughly and dry. Or, gently rub with cleansing powder or soap filled pads as directed. If oven racks are cleaned in the oven during the self-clean mode, they will lose their shiny finish and may not glide smoothly. If this happens, wipe the rack edges with a small amount of vegetable oil, then wipe off excess.
Fiberglass Gasket	DO NOT HAND CLEAN GASKET.
Glass	Wash with soap and water or glass cleaner. Use Fantastik® or Formula 409® to remove grease spatters and stubborn stains.
Painted	Clean with hot sudsy water or apply Fantastik® or Formula 409® to a clean sponge or paper towel and wipe clean. Avoid using powdered cleansers, steel wool pads and oven cleaners.
Porcelain	Immediately wipe up acid spills like fruit juice, milk and tomatoes with a dry towel. Do not use a moistened sponge/towel on hot porcelain. When cool, clean with hot sudsy water or apply Bon-Ami® or Soft Scrub® to a damp sponge. Rinse and dry. For stubborn stains, gently use soap filled pads. It is normal for porcelain to craze (fine lines) with age due to exposure from heat and food soil.
Stainless Steel	Always wipe or rub with grain. Clean with a soapy sponge then rinse and dry. Or, wipe with Fantastik® or Formula 409® sprayed onto a paper towel. Protect and polish with Stainless Steel Magic® and a soft cloth. Remove water spots with a cloth dampened with white vinegar. Use Bar Keeper's Friend® to remove heat discoloration.
Probe	Clean probe by hand with detergent and hot water. Then rinse and dry. Do not soak or clean in dishwasher.
Plastic & Control Panel	When cool, clean with soapy water, rinse and dry.
Drawers (Warming)	When cool, wash with hot soapy water, rinse and dry.

Cookware Selection Guide

For best results, choose cookware based on the following characteristics:

- Aluminum or copper bottomed pans conduct heat evenly.
 - Steel pans, if not combined with other metals, may cook unevenly.
 - Cast-iron cookware absorbs heat slowly and cooks more evenly at low-to-medium settings.
 - Flat, heavy bottom pans provide even heat and stability.
- DO NOT USE pans that are thin, warped, dented or ridged as they heat unevenly.

Match Pan Diameter to Flame Size

- The flame should be the same size as the bottom of the pan or smaller. Do not use small pans with high flame settings as the flames can lick up the sides of the pan.
- Oversize pans that span two burners are placed on the left side, front to rear (not side to side).



Use Balanced Pans

- Pans must sit level on the cooktop grate without rocking.
- Center pan over burner.



Use a Lid That Fits Properly

- A well-fitting lid helps shorten the cooking time.



- Use a **wok** with a flat bottom.
- For **simmering stews and soups**, use right front burner. For melting chocolate, use the burner in the right rear position.
- **Canners and pressure cookers** must meet the same requirements as described above. After bringing contents to a boil, use lowest heat setting possible to maintain a boil or pressure (for pressure canners/cookers).

Removing the Door

WARNING

- Make sure oven is cool and power to the oven has been turned off before removing the door. Failure to do so could result in electrical shock or burns.
- The oven door is heavy and fragile. Use both hands to remove the oven door. The door front is glass. Handle carefully to avoid breakage.
- Grasp only the sides of the oven door. Do not grasp the handle as it may swing in your hand and cause damage or injury.
- Failure to grasp the oven door firmly and properly could result in personal injury or product damage.

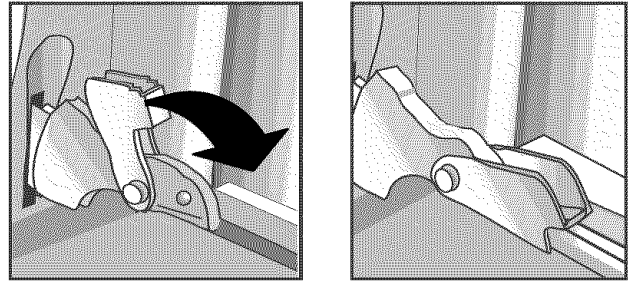

Figure A

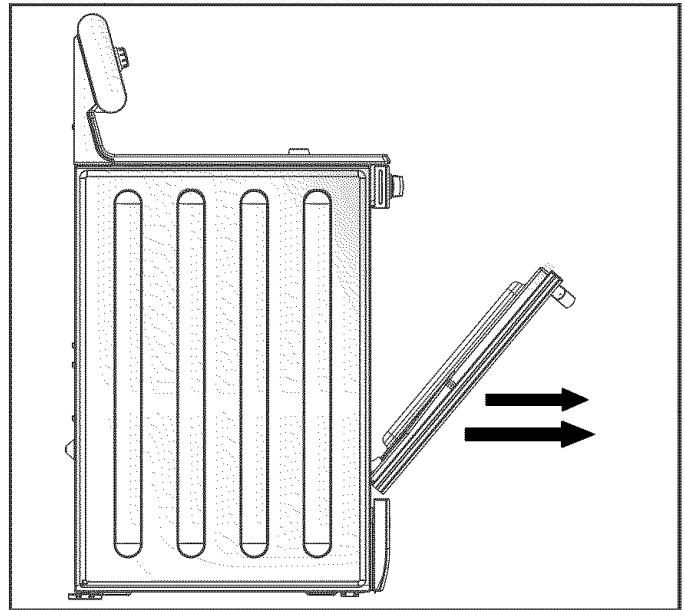

Figure B

1. Be sure to read the above **WARNING** before attempting to remove oven door.
2. Open the door completely.
3. Flip lever on hinge toward you. (see Figure A).
4. Close the door to approximately halfway open.
5. Holding the door firmly on both sides using both hands, pull the door straight out of the hinge slots. Hold firmly, the door is heavy (See Figure B).
6. Place the door in a convenient and stable location for cleaning.

Replacing the Oven Door

- The door can be replaced by reversing the above procedure.
- After moving the hinge brackets back down into position, be sure to close and open the door slowly to assure that it is correctly and securely in place.
- Door should be straight, not crooked.

Replacing an Oven Light

1. Read **WARNING** at right.
 2. Turn off power at the main power supply (fuse or breaker box).
 3. Remove the lens by unscrewing it.
 4. Remove the light bulb from its socket by unscrewing it.
 5. Replace the bulb with a new one. Use a 40Watt approved appliance bulb. Avoid touching the bulb with fingers, as oils from hands can damage the bulb when it becomes hot.
 6. Screw the lens back on.
 7. Turn power back on at the main power supply (fuse or breaker box).
- Your range has two oven lights.
 - Each light assembly consists of a removable lens, a light bulb as well as a light socket housing that is fixed in place.



WARNING

- Make sure the oven and lights are cool and power to the oven has been turned off before replacing the light bulb(s). Failure to do so could result in electrical shock or burns.
- The lenses must be in place when using the oven.
- The lenses serve to protect the light bulb from breaking.
- The lenses are made of glass. Handle carefully to avoid breakage. Broken glass could cause an injury.
- Light socket is live when door is open.

Self Help - Cooktop

PROBLEM	POSSIBLE CAUSE(S)	SOLUTION(S)
Burners click continuously.	Knob(s) are in the "light" position.	Turn knob(s) to "OFF" position or to desired flame setting.
Surface burners do not light.	Gas is turned off.	Make sure the gas shut-off valve is in the ON position and the gas supply to the house is not shut off.
	Unit is not hooked up to gas supply.	Call gas company.
	Plug is not completely inserted into outlet.	Incorrect house wiring. Check the power supply. Verify that the unit is grounded with the correct polarity. Make sure the unit is plugged in.
	Circuit breaker is tripped.	Check circuit breaker and reset if necessary. Check and/or replace fuse.
	Burner ports are clogged.	With the cooktop turned off and cool, remove burner caps. Use a stiff nylon bristle toothbrush to push debris through burner ports.
	Misaligned burner cap.	Verify that burner caps are properly positioned over burners.
	Ignitor is wet, damaged or dirty.	Check ignitor for moisture. If wet, allow to air dry before using. Check for burned-on food or grease. See cleaning recommendations, page 23. Burner will not light if ignitor is wet, damaged or dirty.
Uneven or too high flame, burner is hard to light.	Burner ports are clogged.	With the cooktop turned off and cool, remove burner caps. Use a stiff nylon bristle toothbrush to dislodge debris.
	Misaligned burner cap.	Verify that burner caps are properly positioned over burners.
	Burner cap is wet.	Turn off burner, cool and dry burner cap and burner base thoroughly.
Uneven flame - LP/ bottled gas users.	LP conversion not completed properly.	Call service.

Self Help - Oven

PROBLEM	POSSIBLE CAUSE(S)	SOLUTION(S)
The oven mode or temperature does not appear in the display.	The knob was turned too rapidly.	Turn the knob slowly when selecting a mode or temperature. Review manual instructions when setting the clock, the timer or self-clean.
The oven door is locked and will not release after self-clean cycle.	Oven is too hot.	The oven door is designed to remain locked after a self-clean cycle until a safe temperature is reached.
The oven door is locked and will not release, even after cooling.	Oven door latch needs to be reset.	Turn the oven off at the circuit breaker and wait five (5) minutes. Turn the oven back on. The oven latch will be reset and the door will open.
Oven is not heating.	Oven temperature is not selected.	Verify that correct temperature has been selected.
	Oven is not receiving proper electrical power.	Verify that the circuit breaker and/ or fuse box are working properly. Verify hat plug is completely inserted into outlet.
Oven does not cook evenly, food is undercooked or food is overcooked.	Incorrect rack position used.	Refer to recipe, package directions or cooking charts for proper rack position.
	Oven calibration is incorrect.	Adjust oven calibration (See "Oven Temperature Offset", page 9).
	Using convection bake mode.	Always reduce temperature by 25° F when using convection bake mode.
Oven light does not come on.	Bulb is loose, broken or burned out.	Verify that bulb is correctly installed. Replace broken or burned out bulb. Note: touching the bulb with fingers may cause it to burn out.
	The oven light will not light during the self-clean mode.	This is normal. See Self-Cleaning section.
	The oven light cannot be changed once the Sabbath mode has started.	This is normal. See Sabbath Mode section.
Oven light will not turn off.	Oven door is not closing properly.	Check for obstructions between door and range. Check for bent hinges.
	The oven light cannot be changed once the Sabbath mode has started.	This is normal. See Sabbath Mode section.
Clock and/ or Timer are not working properly.	Electical power to range has been interrupted.	Check electrical connections. Reset clock after power is restored. See "Setting the Clock Time", page 6.
	Clock is set incorrectly.	Reset clock time. See "Changing the Clock Time", page 6.

Self Help - Oven (Cont'd)

PROBLEM	POSSIBLE CAUSE(S)	SOLUTION(S)
Oven does not self-clean properly.	Oven was not properly prepared for the self-clean process.	<ul style="list-style-type: none"> • Allow oven to cool before starting self-clean mode. • Wipe out loose soils or heavy spillover. • If oven is badly soiled, set self-clean mode for five (5) hours. • See section "Preparing the Oven for Self-Clean", page 24.
Porcelain chips.	Oven racks were incorrectly removed.	<p>Always tilt racks up when removing. Do not force racks.</p> <p>Tip: Apply vegetable oil to rack edges and wipe with a paper towel after cleaning to ease glide.</p>
"F" and a number appears in display and control beeps.	This is a fault code.	Press OFF to clear display. Reset oven if necessary. If fault code remains, turn oven off and call for service.
There is a strong odor when a new oven is turned on.	This is normal.	The odor will disappear after a few uses. Operating the self-clean mode will also help to "burn off" the smell more quickly.

General Range Troubleshooting Tips:

1. Verify that gas shut-off valve is in the ON position and the gas supply to the house is not shut off.
2. Verify that the burner caps are positioned and the burner ports are not clogged. Clear ports with a stiff nylon bristle toothbrush if clogged.
3. Verify that the igniters are clean and dry.
4. Verify that there is no draft in the room.
5. Check the power supply. It should be properly grounded with the correct polarity. Verify that the unit is plugged in and the circuit breaker is not tripped.

Note: When the electrical power connection has been activated at the first power up or after an outage, the igniters may spark once or twice even though all burner knobs are in the off position.

If the cooktop is still not operating properly, please contact your dealer or call BSH Customer Service at 800-944-2904.

Replacement Parts

Replacement parts are available through your Bosch dealer. Contact Bosch Service for a dealer near you: 800-944-2904 or www.boschappliances.com

Statement of Limited Warranty

The warranties provided by BSH Home Appliances Corp. in this Statement of Limited Warranty apply only to the BSH Gas Freestanding Range ("Range") sold to you, the first using purchaser, provided that the Range was purchased (1) for your use and not for resale and (2) in the United States or Canada and is located in the country of purchase. As used in this Statement of Limited Warranty, the term "Date of Installation" shall refer to the earlier of the date the Range is installed or ten (10) business days after the date the Range is sold to the first using purchaser, the warranties stated herein apply only to the first using purchaser and are not transferable.

Standard Limited Warranty

BSH warrants that its Range is free from defects in materials and workmanship for a period of twelve (12) months from the date of installation. During the warranty period, BSH or its authorized service center will repair or replace, at its sole option, any Range that proves to have been defective under conditions of normal use without charge. All removed parts and components shall become the property of BSH, at BSH's option. All replaced and/or repaired parts shall assume the identity of the original part for purposes of this warranty and this warranty shall not be extended with respect to such parts.

Other Conditions of the Limited Warranties

The warranties provided in this Statement of Limited Warranty exclude defects or damage resulting from (1) use of the Range in other than its normal and customary manner (commercial use of the Range shall not be deemed normal or customary), (2) misuse, abuse, accidents or neglect, (3) improper operation, maintenance, installation or unauthorized service, (4) adjustment or alteration or modification of any kind, (5) a failure to comply with applicable state, local, city, and county electrical and/or building codes, (6) spills of food or liquid, and (7) external forces such as floods, fires, acts of God or other circumstances beyond BSH's control. Also excluded from this warranty are scratches and damages on external surfaces and exposed parts of Range on which the serial numbers have been altered, defaced or removed.

To the extent allowed by law, this warranty sets out your exclusive remedies with respect to products covered by it, whether the claim arises in contract or tort (including strict liability and negligence) or otherwise. THE FOREGOING REPRESENTS THE TOTAL EXTENT OF BSH'S RESPONSIBILITY AND LIABILITY WITH REGARD TO THE PRODUCT. IN NO EVENT WHATSOEVER SHALL BSH BE LIABLE FOR ANY DAMAGES, INCLUDING WITHOUT LIMITATION CONSEQUENTIAL, PUNITIVE, INCIDENTAL, SPECIAL, INDIRECT, OR DIRECT DAMAGES, OR FOR ANY ACTS OR OMISSIONS OF THIRD PARTIES, INCLUDING WITHOUT LIMITATION THOSE OF A DEALER, TRANSPORTER, INSTALLER, OR SERVICER. BSH MAKES NO OTHER WARRANTY, AND SHALL NOT BE DEEMED TO HAVE MADE ANY OTHER WARRANTY, EXCEPT AS EXPRESSLY PROVIDED FOR HEREIN, WHETHER EXPRESS OR IMPLIED, INCLUDING WITHOUT LIMITATION ANY WARRANTY OF FITNESS FOR A PARTICULAR PURPOSE OR WARRANTY OF MERCHANTABILITY. IN ANY EVENT, ANY WARRANTY IMPOSED AT LAW SHALL NOT BE EFFECTIVE FOR ANY PERIOD OF TIME LONGER THAN THE APPLICABLE PERIOD EXPRESSED HEREIN. No attempt to alter, modify, or amend this warranty shall be effective unless authorized in writing by an officer of BSH.

How to Obtain Warranty Service

To obtain warranty service for the Range, you should contact the nearest BSH authorized service center or the BSH Customer Support Call Center, 5551 McFadden Avenue, Huntington Beach, CA 92649, 800/944-2904.

NOTICE TO CALIFORNIA OWNERS

If your Range needs warranty service and there is no authorized BSH service center reasonably close to you, you may notify the BSH reseller from whom you purchased the Range. If the BSH reseller fails to repair or replace the defective parts, or partially refund your purchase price (where applicable), you may have the Range repaired at any large appliance repair shop or center and you will be reimbursed for all reasonable expenses provided the costs are substantiated in writing and the work performed is covered by this warranty. BSH shall not reimburse any repair costs hereunder which exceed the depreciated value of the Range.