

# 650 CardioCrossTrainer

## USER'S MANUAL

Model No. 831.285371

Serial No. \_\_\_\_\_

Write the serial number in the space above for future reference.

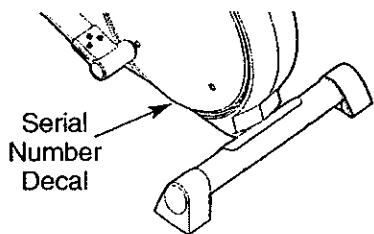

EXERCISE  
EQUIPMENT

QUESTIONS

HELPLINE!

1-800-736-6879

SEARS, ROEBUCK AND CO.,  
HOFFMAN ESTATES, IL 60179

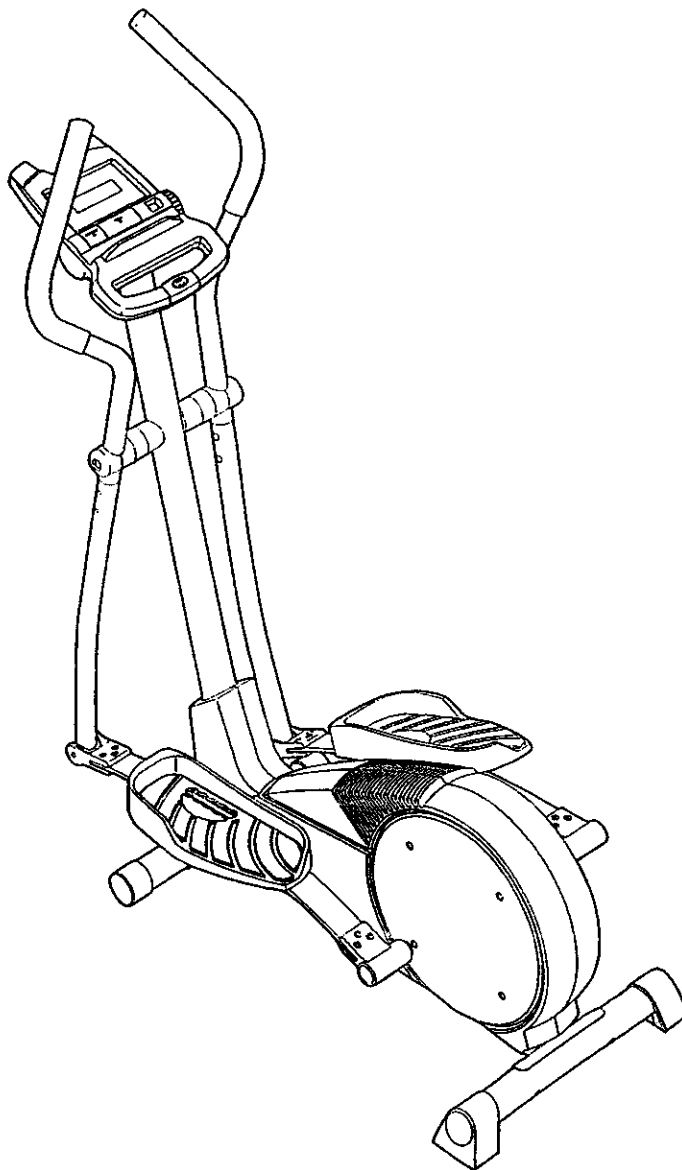

### CAUTION

Read all precautions and instructions in this manual before using this equipment. Keep this manual for future reference.



Visit our website at

[www.proform.com](http://www.proform.com)

*new products, prizes,  
fitness tips, and much more!*

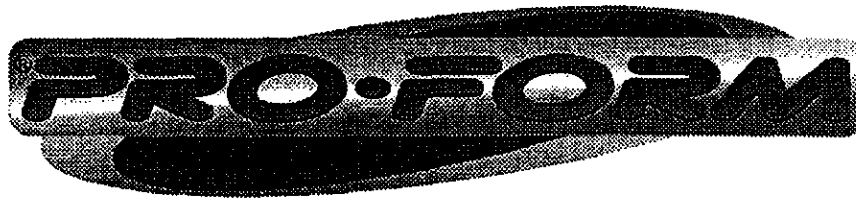

# 650 CardioCrossTrainer

---

## TABLE OF CONTENTS

IMPORTANT PRECAUTIONS .....	3
BEFORE YOU BEGIN .....	4
ASSEMBLY .....	5
HOW TO USE THE ELLIPTICAL CROSSTRAINER .....	9
MAINTENANCE AND TROUBLESHOOTING .....	12
CONDITIONING GUIDELINES .....	13
PART LIST .....	14
EXPLODED DRAWING .....	15
HOW TO ORDER REPLACEMENT PARTS .....	Back Cover
FULL 90 DAY WARRANTY .....	Back Cover

---

# IMPORTANT PRECAUTIONS

**▲ WARNING:** To reduce the risk of serious injury, read the following important precautions before using the elliptical crosstrainer.

1. Read all instructions in this manual before using the elliptical crosstrainer.
2. It is the responsibility of the owner to ensure that all users of the elliptical crosstrainer are adequately informed of all precautions.
3. Place the elliptical crosstrainer on a level surface, with a mat beneath it to protect the floor or carpet. Keep the elliptical crosstrainer indoors, away from moisture and dust.
4. Inspect and properly tighten all parts regularly. Replace any worn parts immediately.
5. Keep children under 12 and pets away from the elliptical crosstrainer at all times.
6. The elliptical crosstrainer should not be used by persons weighing more than 250 pounds.
7. Wear appropriate exercise clothing when using the elliptical crosstrainer. Always wear athletic shoes for foot protection.
8. Always hold the console handgrip or the handlebars when mounting, dismounting, or using the elliptical crosstrainer.
9. The heart rate sensor is not a medical device. Various factors may affect the accuracy of heart rate readings. The heart rate sensor is intended only as an exercise aid in determining heart rate trends in general.
10. Keep your back straight when using the elliptical crosstrainer; do not arch your back.
11. If you feel pain or dizziness at any time while exercising, stop immediately and begin cooling down.
12. When you stop exercising, allow the pedals to slowly come to a stop.
13. The elliptical crosstrainer is intended for home use only. Do not use the elliptical crosstrainer in a commercial, rental, or institutional setting.

**▲ WARNING:** Before beginning this or any exercise program, consult your physician. This is especially important for persons over the age of 35 or persons with pre-existing health problems. Read all instructions before using. SEARS assumes no responsibility for personal injury or property damage sustained by or through the use of this product.

# BEFORE YOU BEGIN

Congratulations for selecting the new PROFORM® 650 CARDIO CROSSTRAINER. The PROFORM® 650 is an incredibly smooth exerciser that moves your feet in a natural elliptical path, minimizing the impact on your knees and ankles. And the unique PROFORM® 650 features adjustable resistance and a state-of-the-art console to help you get the most from your exercise. Welcome to a whole new world of natural, elliptical-motion exercise from PROFORM.

**For your benefit, read this manual carefully before you use the PROFORM® 650.** If you have questions

after reading the manual, please call our toll-free HELPLINE at 1-800-736-6879, Monday through Saturday, 7 a.m. until 7 p.m. Central Time (excluding holidays). To help us assist you, please note the product model number and serial number before calling. The model number is 831.285371. The serial number can be found on a decal attached to the elliptical crosstrainer (see the front cover of this manual for the location of the decal).

Before reading further, please familiarize yourself with the parts that are labeled in the drawing below.

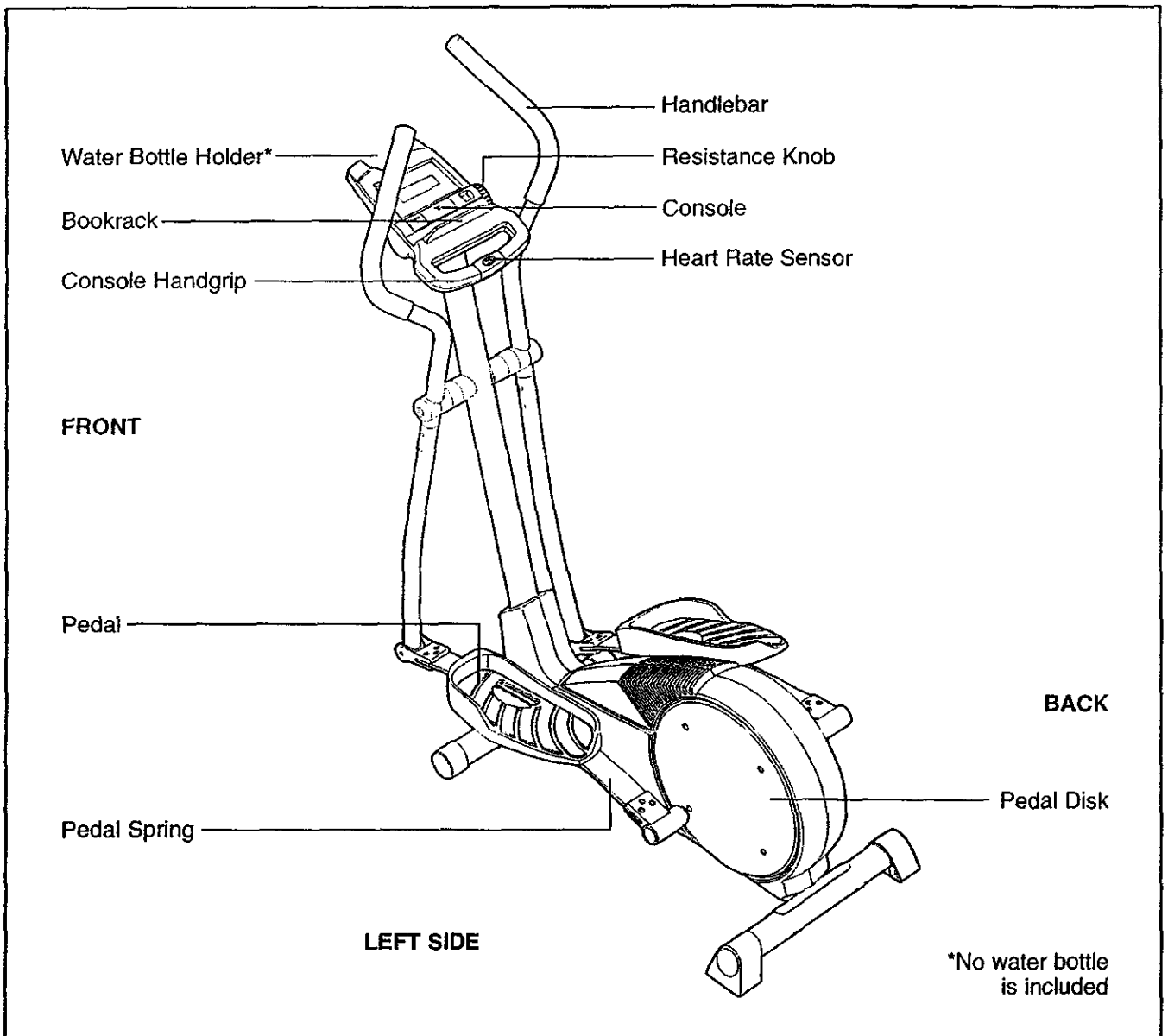

# ASSEMBLY

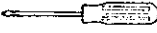
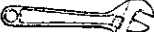
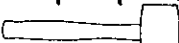
Assembly requires two persons. Place all parts of the elliptical crosstrainer in a cleared area and remove the packing materials. Do not dispose of the packing materials until assembly is completed. In addition to the included allen wrenches, assembly requires a phillips screwdriver , an adjustable wrench , and a rubber mallet .

As you assemble the elliptical crosstrainer, use the drawings below to identify the small parts used in assembly. The number in parenthesis below each drawing refers to the key number of the part, from the PART LIST on page 14. The second number refers to the quantity used in assembly. **Note: Some small parts may have been pre-assembled for shipping. If a part is not in the parts bag, check to see if it has been pre-assembled.**

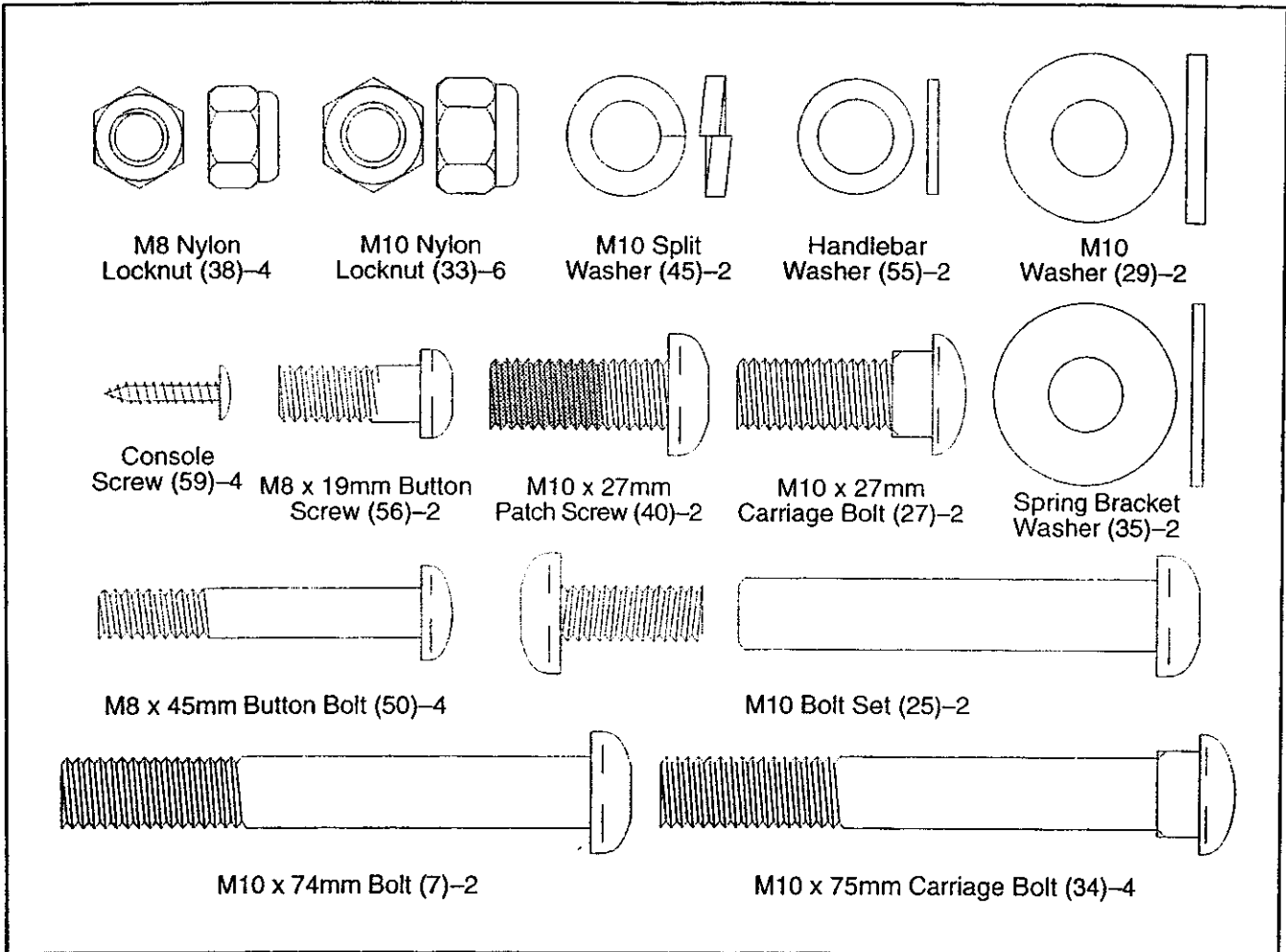

1. Identify the Front Stabilizer (10), which has round Endcaps (21) on it. While another person lifts the front of the Frame (1), attach the Front Stabilizer to the Frame with two M10 x 75mm Carriage Bolts (34) and two M10 Nylon Locknuts (33).

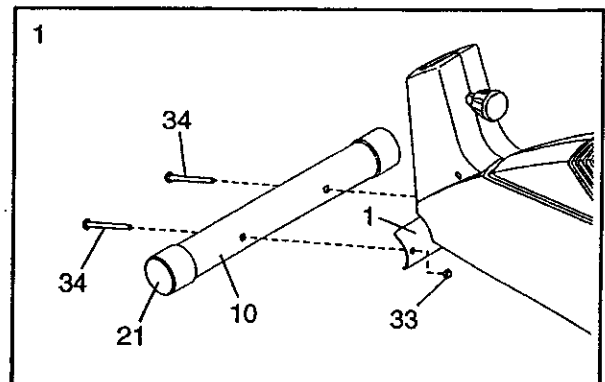

2. While another person lifts the back of the Frame (1), attach the Rear Stabilizer (9) to the Frame with two M10 x 75mm Carriage Bolts (34) and two M10 Nylon Locknuts (33).

3. The Console (23) requires three "AA" batteries (not included); alkaline batteries are recommended. Insert three batteries into the battery compartment. **Make sure that the batteries are oriented as shown by the diagram inside the battery compartment.**

4. While another person holds the Console (23) in the position shown, insert the control cable and the console wire down through the Upright (2). Attach the ground wire to the Upright with an M4 x 16mm Self-tapping Screw (52). Insert the excess cable and wire into the Upright.

Attach the Console (23) to the Upright (2) with four Console Screws (59). Be careful to avoid pinching the cable and wires.

**Make sure the Resistance Knob (42) is set on the lowest setting before proceeding to the next step.**

5. While another person holds the Upright (2) in the position shown, connect the console wire to the Reed Switch Wire (53).

Next, connect the control cable to the Resistance Cable (43) in the following way:

- Refer to drawing A. Pull up on the metal bracket, and insert the tip of the control cable into the wire clip on the Resistance Cable (43) as shown.
- Refer to drawing B. **Firmly** pull the control cable and slide it into the metal bracket on the Resistance Cable (43) as shown.
- Refer to drawing C. Using pliers, squeeze the prongs on the upper end of the metal bracket together.

Push the excess cable and wires down into the Frame (1). Insert the Upright (2) into the Frame. **Do not pinch the wires or cables.** Secure the Upright to the Frame with two M10 x 74mm Bolts (7), two M10 Split Washers (45), and two M10 Nylon Locknuts (33). **Do not tighten the Bolts yet.**

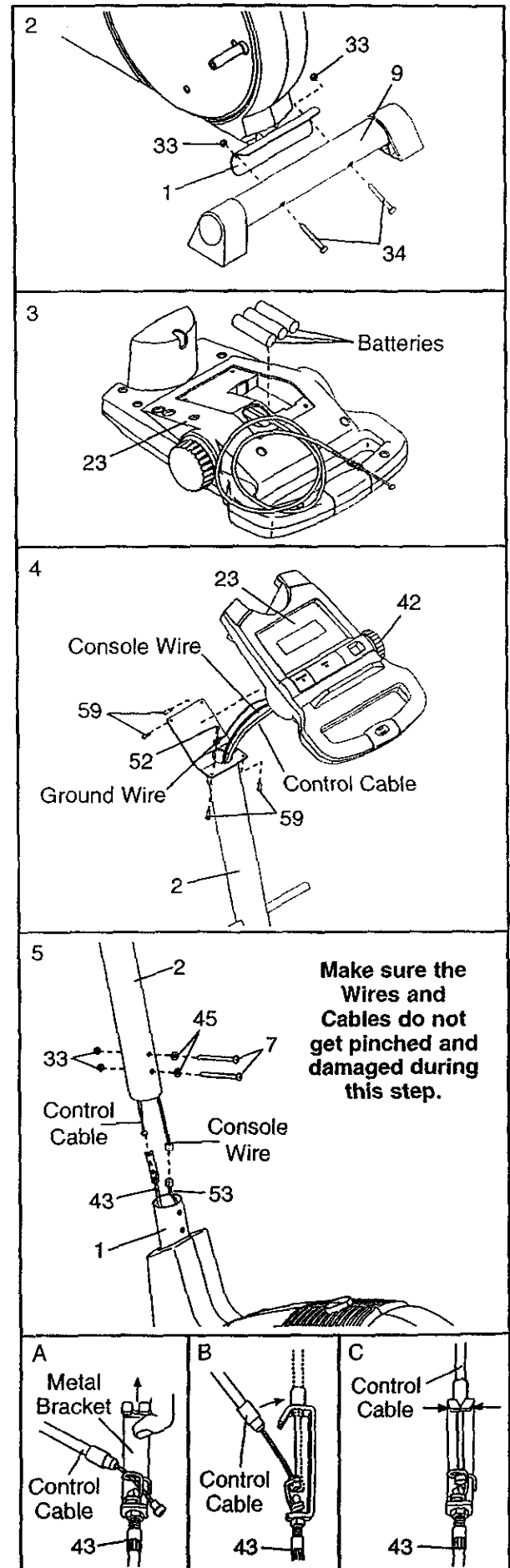

- Identify the Left Handlebar (6), which is marked with a sticker. Insert the Left Handlebar into one of the Handlebar Legs (5); **make sure that the Handlebar Leg is turned so the hexagonal holes are on the indicated side.** Attach the Left Handlebar to the Handlebar Leg with two M8 x 45mm Button Bolts (50) and two M8 Nylon Locknuts (38). **Make sure that the Nylon Locknuts are inside of the hexagonal holes. Do not fully tighten the Button Bolts yet.**

Apply a small amount of the included grease to the left and right axles on the Upright (2).

Make sure that there are two Small Handlebar Bushings (49) in the Left Handlebar (6). Carefully slide an Upright Spacer (48), a Handlebar Spacer (47), the Left Handlebar, and a Handlebar Cap (46) onto the left axle on the Upright (2) as shown. Slide a Handlebar Washer (55) onto an M8 x 19mm Button Screw (56), and tighten the Button Screw into the axle.

Assemble the Right Handlebar (8) and the other Handlebar Leg (5) in the same way.

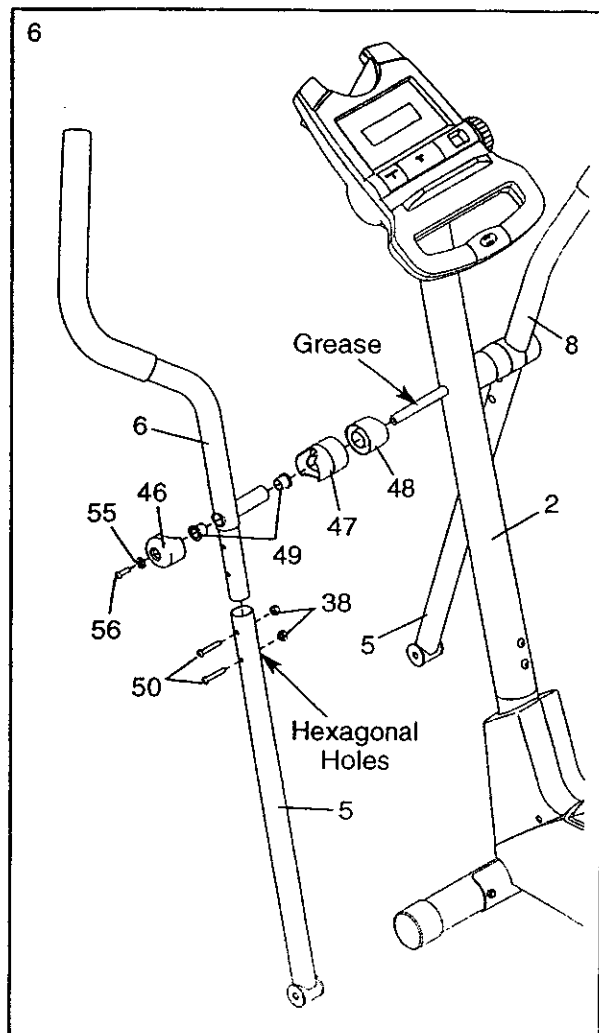

- Identify the left Pedal Spring (11), which is marked with a sticker. Attach the Left Pedal (13) to the left Pedal Spring with an M10 x 27mm Pedal Bolt (27), an M10 Washer (29), and a Pedal Knob (28) as shown. **Note: The Left Pedal can be attached in any of five positions (see HOW TO ADJUST THE PEDALS on page 9).**

Attach the Right Pedal (not shown) in the same way. Make sure that both Pedals are in the same position.

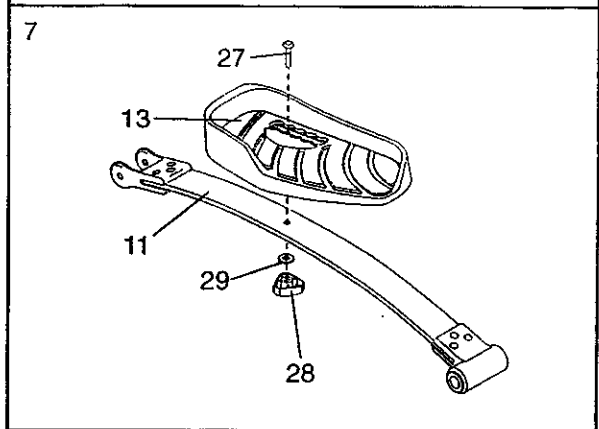

8. Apply a small amount of grease to the axle on the left Disc Crossbar (16). Slide a Spring Spacer (63) onto the axle; **make sure that the Spring Spacer is turned so the flat side is facing the elliptical crosstrainer.** Next, slide the Left Rear Spring Bracket (12) on the left Pedal Spring (11) onto the axle. Slide a Spring Bracket Washer (35) onto an M10 x 27mm Patch Screw (40), and tighten the Patch Screw into the axle.

Next, hold the lower end of the left Handlebar Leg (5) inside of the Front Spring Bracket (65) on the left Pedal Spring (11). Apply grease to an M10 Bolt Set (25). Attach the Handlebar Leg to the Front Spring Bracket with the Bolt Set. **Do not overtighten the Bolt Set; the Handlebar Leg must pivot freely.**

Attach the right Pedal Spring (not shown) to the right side of the elliptical crosstrainer in the same way.

Refer to step 5. Tighten the M10 x 74mm Bolts (7) in the Upright (2).

Refer to step 6. Tighten the M8 x 45mm Button Bolts (50) in the Handlebar Legs (5).

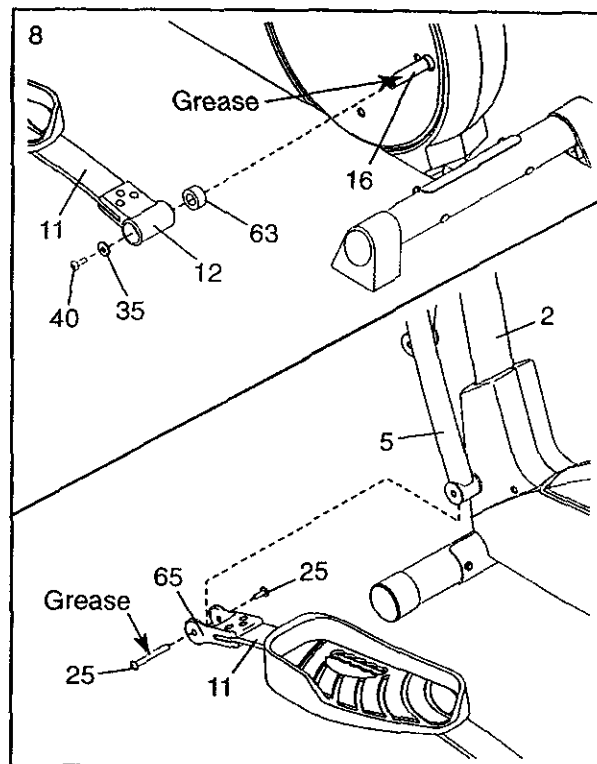

9. **Make sure that all parts of the elliptical crosstrainer are properly tightened.** Note: Some hardware may be left over after assembly is completed. To protect the floor or carpet from damage, place a mat under the elliptical crosstrainer.



# HOW TO USE THE ELLIPTICAL CROSSTRAINER

## HOW TO ADJUST THE RESISTANCE OF THE PEDALS

As you exercise, you can adjust the resistance of the pedals with the resistance knob on the right side of the console. To increase the resistance, turn the knob clockwise; to decrease the resistance, turn the knob counter-clockwise. The number in the resistance window displays the resistance level.

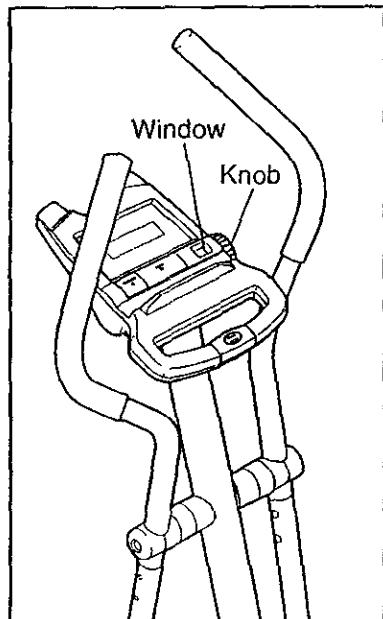

## HOW TO ADJUST THE PEDALS

The motion of the elliptical cross-trainer is determined by the position of the pedals.

To adjust the pedals, first loosen the pedal knobs beneath the pedals. Slide the pedals forward or backward to one of the five positions, and then retighten the knobs. Make sure that both pedals are in the same position.

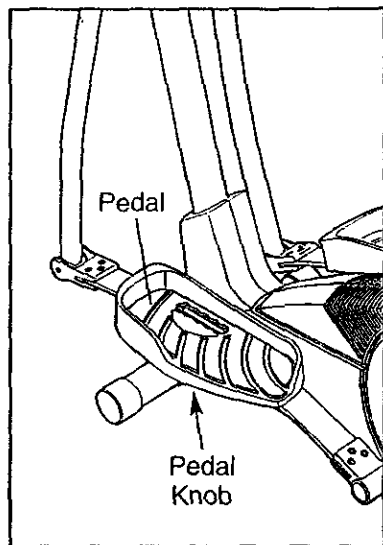

## HOW TO USE THE HANDLEBARS

The handlebars are designed to add upper-body exercise to your workouts. As you exercise, push and pull the handlebars to work your arms, shoulders, and back.

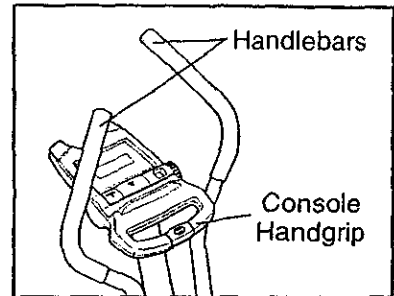

To exercise only your lower body, hold the console handgrip as you exercise.

## HOW TO EXERCISE ON THE ELLIPTICAL CROSSTRAINER

To mount the elliptical cross-trainer, hold the console handgrip and step onto the pedal that is in the lowest position. Then, step onto the other pedal. Push the pedals until they begin to move with a continuous motion. **Note: The pedal disks can turn in either direction. It is recommended that you move the pedal disks in the direction shown by the arrow; however, for variety, you may turn the pedal disks in the opposite direction.**

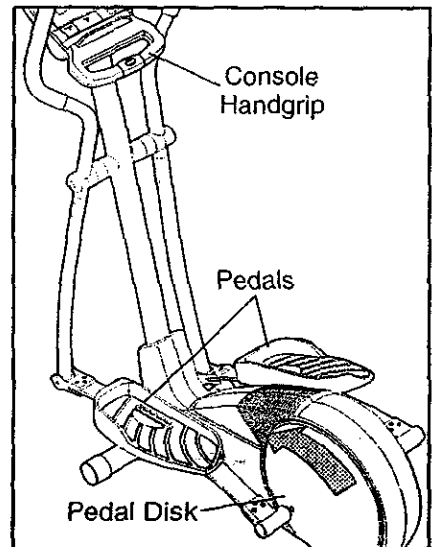

To dismount the elliptical cross-trainer, wait until the pedals come to a complete stop. **(Note: The elliptical cross-trainer does not have a free wheel; the pedals will continue to move until the flywheel stops.)** When the pedals are stationary, step off the highest pedal first. Then, step off the lowest pedal.

## FEATURES OF THE CONSOLE

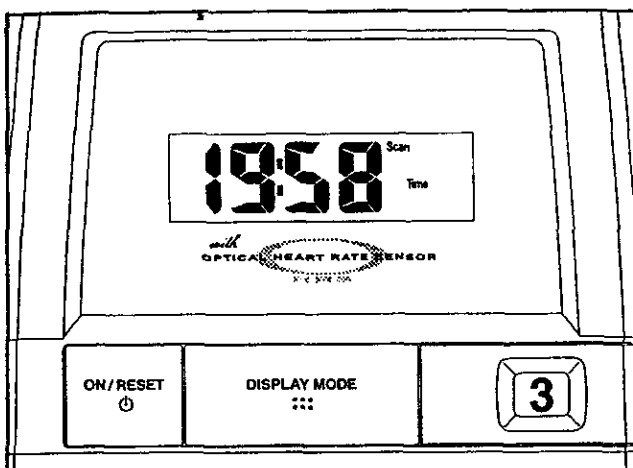

The easy-to-use console features seven modes that provide instant exercise feedback during your workouts. The modes are described below.

**Speed**—This mode displays your pedalling speed.

**Time**—This mode displays the elapsed time. Note: If you stop pedalling for ten seconds or longer, the time mode will pause.

**Distance**—This mode displays the distance you have pedalled.

**Calories**—This mode displays the approximate number of calories you have burned.

**Fat Calories**—This mode displays the approximate number of fat calories you have burned (see FAT BURNING on page 13).

**Scan**—This mode displays the speed, time, distance, calorie, and fat calorie modes, for a few seconds each, in a repeating cycle.

**Heart Rate**—This mode shows your heart rate when you use the heart rate sensor.

**Note:** The console can display speed and distance in either miles or kilometers. To change the unit of measurement, hold down the On/Reset button for a few seconds. The mode indicators will show which unit of measurement is selected. When the batteries are replaced, it may be necessary to reselect the desired unit of measurement.

## HOW TO OPERATE THE CONSOLE

Make sure that there are batteries in the console (see assembly steps 3 and 4 on page 6). If there is a thin sheet of clear plastic on the console, remove it.

Follow the steps below to operate the console.

1. To turn on the power, press the On/Reset button or simply begin pedalling. When the power is turned on, the entire display will appear for two seconds. The console will then be ready for operation.
2. Select one of the seven modes:

### Scan mode—

When the power is turned on, the scan mode will automatically be selected. The scan indicator will appear in the display to show that the scan mode is selected, and a second mode indicator will show which mode is currently displayed. Note: If a different mode is selected, you can select the scan mode again by repeatedly pressing the Display Mode button.

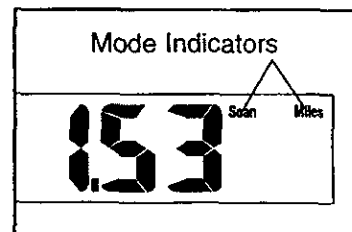

### Speed, time, distance, calories, or fat calories mode—

To select one of these modes for continuous display, press the Display Mode button repeatedly until only the MPH (or Km/H), Time, Miles (or Kms), Cals., or Fat Cals. indicator appears in the display. Make sure that the Scan indicator does not appear.

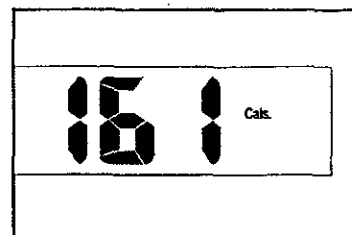

To reset the display at any time, press the On/Reset button.

3. Measure your heart rate, if desired.

To measure your heart rate, stop pedaling and place your thumb on the heart rate sensor as shown.

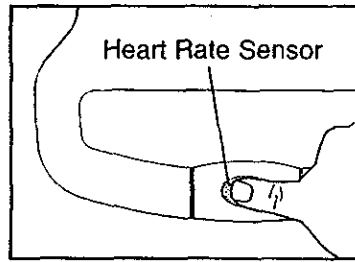

**Do not press too hard, or the circulation in your thumb will be restricted, and your pulse will not be detected.** After a few seconds, the heart-shaped indicator in the display will flash **steadily**, two dashes will appear, and then your heart rate will be shown. Hold your thumb on the heart rate sensor for another 15 seconds for the most accurate reading. If the displayed heart rate appears to be too high or too low, or if your heart rate is not displayed, lift your thumb off the heart rate sensor and allow the display to reset. Then, place your thumb on the heart rate sensor as described above.

Make sure that you are applying the proper amount of pressure to the heart rate sensor. Try the heart rate sensor several times until you become familiar with it. Remember to stand still while measuring your heart rate.

**⚠ WARNING:** The heart rate sensor is not a medical device. Various factors may affect the accuracy of heart rate readings. The heart rate sensor is intended only as an exercise aid in determining heart rate trends in general.

4. To turn off the power, simply wait for a few minutes. **The console has an “auto-off” feature. If the pedals are not moved and the On/Reset button is not pressed for a few minutes, the power will turn off automatically to conserve the batteries.**

# MAINTENANCE AND TROUBLESHOOTING

Inspect and tighten all parts of the elliptical crosstrainer regularly. Replace any worn parts immediately.

To clean the elliptical crosstrainer, use a damp cloth and a small amount of mild detergent. **Important: Keep liquids away from the console and keep the console out of direct sunlight. During storage, remove the batteries from the console.**

## BATTERY REPLACEMENT

If the console display becomes dim, the batteries should be replaced. Refer to assembly steps 3 and 4 on page 6 for replacement instructions.

## HOW TO ADJUST THE REED SWITCH

If the console does not display correct feedback, the reed switch should be adjusted. To do this, you must remove the Pedal Springs (11), the right Pedal Disc (15), and the Side Shields (3, 4). Refer to step 8 on page 8 and remove the Pedal Springs.

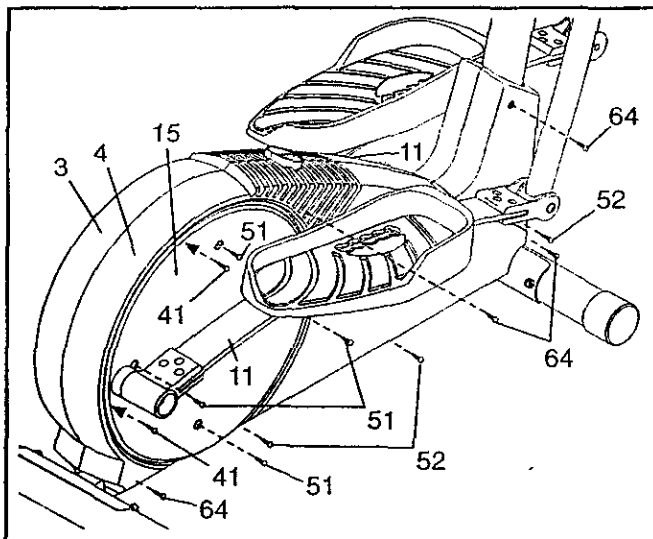

Next, remove the four Screws (51) from the right Pedal Disc (15), and slide the Pedal Disc off. Remove all Screws (52, 64) from the Right Side Shield (4) and the two Bolts (41) from beneath the Pedal Disc, and remove the Right Side Shield (4). Remove all Screws (52) from the Left Side Shield (3), and remove the Left Side Shield.

Next, refer to the drawing below and locate the Reed Switch (53). Loosen, but do not remove, the indicated M4 x 16mm Self-tapping Screw (52). Slide the Reed Switch slightly toward or away from the Magnet (58) on the flywheel. Retighten the Screw. Turn the left Pedal Disc (15) for a moment. Repeat until the console displays correct feedback. When the Reed Switch is correctly adjusted, reattach the Side Shields (3, 4), the right Pedal Disc (15), and the Pedal Springs (11).

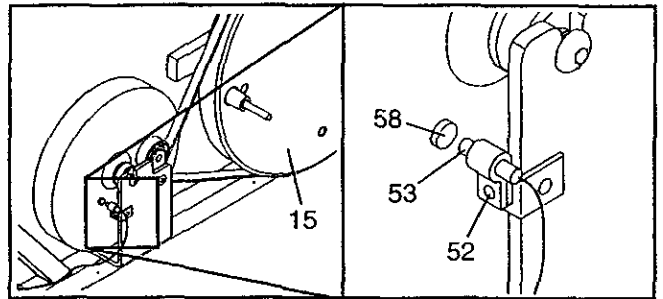

## HOW TO ADJUST THE DRIVE BELT

If you can feel the pedals slip while you are pedaling, even when the resistance is adjusted to the highest level, the Drive Belt (19) may need to be adjusted. To adjust the Drive Belt, you must first remove both side shields. Refer to HOW TO ADJUST THE REED SWITCH at the left and remove the side shields.

Next, loosen the M8 x 22mm Flat Head Screw (68) and turn the M10 x 60mm Bolt (62) until the Drive Belt (19) is tight. When the Drive Belt is tight, tighten the Flat Head Screw. Reattach the side shields.

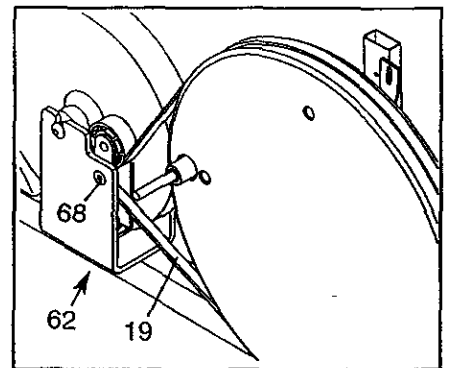

# CONDITIONING GUIDELINES

## ⚠ WARNING:

- Before beginning this or any exercise program, consult your physician. This is especially important for persons over the age of 35 or persons with pre-existing health problems.
- The heart rate sensor is not a medical device. Various factors may affect the accuracy of heart rate readings. The heart rate sensor is intended only as an exercise aid in determining heart rate trends in general.

The following guidelines will help you to plan your exercise program. Remember that proper nutrition and adequate rest are essential for successful results.

### EXERCISE INTENSITY

Whether your goal is to burn fat or to strengthen your cardiovascular system, the key to achieving the desired results is to exercise with the proper intensity. The proper intensity level can be found by using your heart rate as a guide. The chart below shows recommended heart rates for fat burning, maximum fat burning, and cardiovascular (aerobic) exercise.

165	155	145	140	130	125	115	♥
145	138	130	125	118	110	103	♥
125	120	115	110	105	95	90	♥
<hr/>							
20	30	40	50	60	70	80	

To find the proper heart rate for you, first find your age on the bottom line of the chart (ages are rounded off to the nearest ten years). Next, find the three numbers above your age. The three numbers are your "training zone." The lower two numbers are recommended heart rates for fat burning; the highest number is the recommended heart rate for aerobic exercise.

### Fat Burning

To burn fat effectively, you must exercise at a relatively low intensity level for a sustained period of time.

During the first few minutes of exercise, your body uses easily accessible *carbohydrate* calories for energy. Only after the first few minutes of exercise does your body begin to use stored *fat* calories for energy. If your goal is to burn fat, adjust the intensity of your exercise until your heart rate is near the lowest number in your training zone as you exercise.

For maximum fat burning, adjust the intensity of your exercise until your heart rate is near the middle number in your training zone as you exercise.

### Aerobic Exercise

If your goal is to strengthen your cardiovascular system, your exercise must be "aerobic." Aerobic exercise is activity that requires large amounts of oxygen for prolonged periods of time. This increases the demand on the heart to pump blood to the muscles, and on the lungs to oxygenate the blood. For aerobic exercise, adjust the intensity of your exercise until your heart rate is near the highest number in your training zone as you exercise.

### WORKOUT GUIDELINES

Each workout should include the following three parts:

**A warm-up**, consisting of 5 to 10 minutes of stretching and light exercise. A proper warm-up increases your body temperature, heart rate, and circulation in preparation for exercise.

**Training zone exercise**, consisting of 20 to 30 minutes of exercising with your heart rate in your training zone. (During the first few weeks of your exercise program, do not keep your heart rate in your training zone for longer than 20 minutes.)

**A cool-down**, with 5 to 10 minutes of stretching. This will increase the flexibility of your muscles and will help to prevent post-exercise problems.

### EXERCISE FREQUENCY

To maintain or improve your condition, complete three workouts each week, with at least one day of rest between workouts. After a few months of regular exercise, you may complete up to five workouts each week if desired. The key to success is to make exercise a regular and enjoyable part of your everyday life.

# PART LIST—Model No. 831.285371

R0902A

Key No.	Qty.	Description	Key No.	Qty.	Description
1	1	Frame	37	4	Pedal Arm Bushing
2	1	Upright	38	5	M8 Nylon Locknut
3	1	Left Side Shield	39	1	M10 Washer
4	1	Right Side Shield	40	2	M10 x 27mm Patch Screw
5	2	Handlebar Leg	41	2	M6 x 18mm Bolt
6	1	Left Handlebar	42	1	Resistance Knob
7	2	M10 x 74mm Bolt	43	1	Resistance Cable
8	1	Right Handlebar	44	1	Right Rear Spring Bracket
9	1	Rear Stabilizer	45	2	M10 Split Washer
10	1	Front Stabilizer	46	2	Handlebar Cap
11	2	Pedal Spring	47	2	Handlebar Spacer
12	1	Left Rear Spring Bracket	48	2	Frame Spacer
13	1	Left Pedal	49	4	Small Handlebar Arm Bushing
14	1	Right Pedal	50	4	M8 x 45mm Button Bolt
15	2	Pedal Disc	51	8	M6 x 25mm Screw
16	2	Disc Crossbar	52	9	M4 x 16mm Self-tapping Screw
17	1	Flywheel	53	1	Reed Switch/Wire
18	1	Side Shield Bracket	54	1	Cable Clamp
19	1	Drive Belt	55	2	Handlebar Washer
20	2	Rear Endcap	56	2	M8 x 19mm Button Screw
21	2	Front Endcap	57	1	M10 Flat Head Bolt
22	1	Belt Idler	58	1	Magnet
23	1	Console	59	4	Console Screw
24	2	Handgrip	60	4	Large Handlebar Arm Bushing
25	2	M10 Bolt Set	61	2	5/16" x 25.4mm Hex Bolt
26	12	M6 Washer	62	1	M10 x 60mm Bolt
27	2	M10 x 27mm Carriage Bolt	63	2	Spring Spacer
28	2	Pedal Knob	64	4	M4 x 25mm Screw
29	3	M10 Washer	65	2	Front Spring Bracket
30	2	Large Snap Ring	66	14	M6 Nylon Locknut
31	2	Large Bearing	67	2	M5 x 14mm Self-tapping Screw
32	1	Pedal Axle	68	1	M8 x 22mm Flat Head Screw
33	7	M10 Nylon Locknut	69	2	Handlebar Endcaps
34	4	M10 x 75mm Carriage Bolt	#	1	Allen Wrench
35	2	Spring Bracket Washer	#	1	Grease
36	12	M6 x 33.5mm Bolt	#	1	User's Manual

Note: # indicates a non-illustrated part. Specifications are subject to change without notice.

# EXPLODED DRAWING—Model No. 831.285371

R0902A

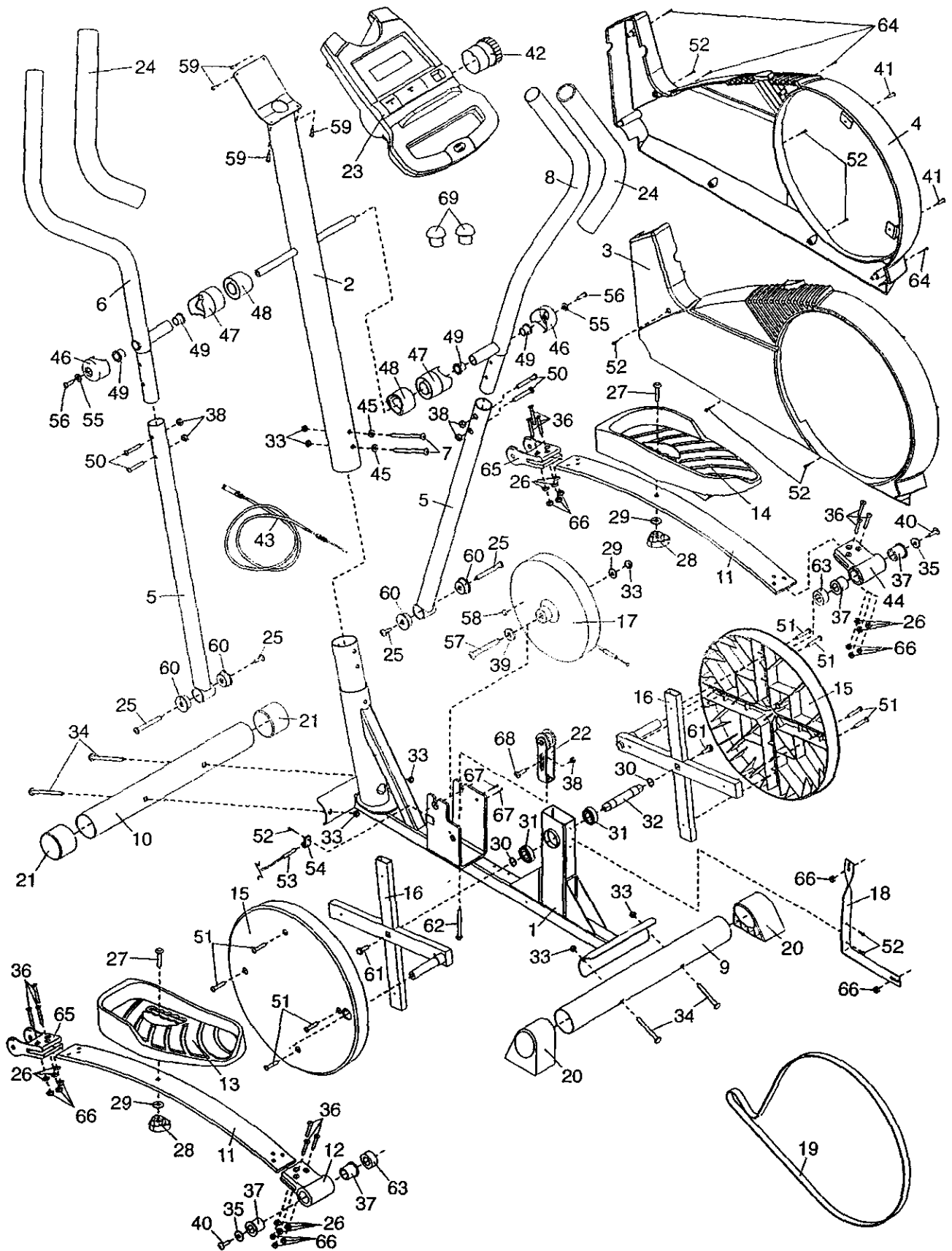



Model No. 831.285371

## QUESTIONS?

If you find that:

- you need help assembling or operating the PROFORM® 650 CARDIO CROSSTRAINER
- a part is missing
- or you need to schedule repair service

call our toll-free HELPLINE

**1-800-736-6879**

Monday–Saturday, 7 am–7 pm  
Central Time (excluding holidays)

## REPLACEMENT PARTS

If parts become worn and need to be replaced, call the following toll-free number

**1-800-FON-PART**  
**(1-800-366-7278)**

The model number and serial number of your PROFORM® 650 CARDIO CROSSTRAINER are listed on a decal attached to the frame. See the front cover of this manual to find the location of the decal.

All replacement parts are available for immediate purchase or special order when you visit your nearest SEARS Service Center. To request service or to order parts by telephone, call the toll-free numbers listed at the left.

When requesting help or service, or ordering parts, please be prepared to provide the following information:

- The NAME OF THE PRODUCT (PROFORM® 650 CARDIO CROSSTRAINER)
- The MODEL NUMBER OF THE PRODUCT (831.285371)
- The KEY NUMBER OF THE PART (see page 15)
- The DESCRIPTION OF THE PART (see page 14)

## FULL 90 DAY WARRANTY

For 90 days from the date of purchase, if failure occurs due to defect in material or workmanship in this SEARS ELLIPTICAL EXERCISER, contact the nearest SEARS Service Center throughout the United States and SEARS will repair or replace the ELLIPTICAL EXERCISER, free of charge.

This warranty does not apply when the ELLIPTICAL EXERCISER is used commercially or for rental purposes.

This warranty gives you specific legal rights, and you may also have other rights which vary from state to state.

**SEARS, ROEBUCK AND CO., DEPT. 817WA, HOFFMAN ESTATES, IL 60179**