

RANGE HOODS

Size
Installation Type
Air Discharge
Air Delivery
Blower Type
Controls
Fan Speeds
Halogen Lights
Washable Aluminum Filters
Filter Saturation LED Indicator
Exhaust Duct
Diameter of Duct

PLHV42P8CC

42"
Peninsula/Island
Vertical
600 CFM
Dual Centrifugal
Electronic
4
4
3
Yes
External
8"

PLHV36W7CC

36"
Wall Mount
Vertical
350 CFM
Dual Centrifugal
Electronic
4
2
2
Yes
External
6"

PLHV36W6CC

36"
Wall Mount
Vertical
360 CFM
Dual Centrifugal
Mechanical
4
2
3
No
External
6"

SPECIFICATIONS

Electrical – 120V AC/60Hz/15 or 20 Amps
Product Weight
Shipping Weight
UPC (0-12505-)

Required
86 Lbs.
118.6 Lbs.
55673-9

Required
44 Lbs.
91.5 Lbs.
55674-6

Required
42 Lbs.
47.5 Lbs.
55675-3

NOTE: Always consult local and/or national electric codes. Refer to Product Installation Guide for detailed installation instructions or visit us on the web at www.electroluxusa.com.

PLHV42P8CC

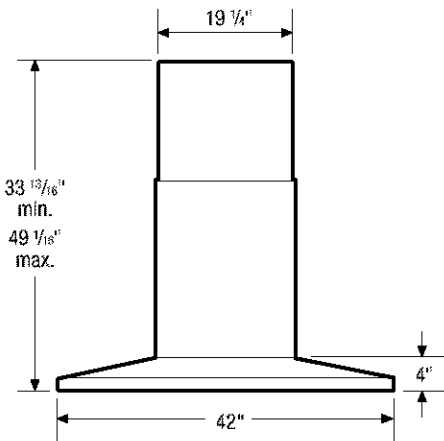

PLHV36W7CC

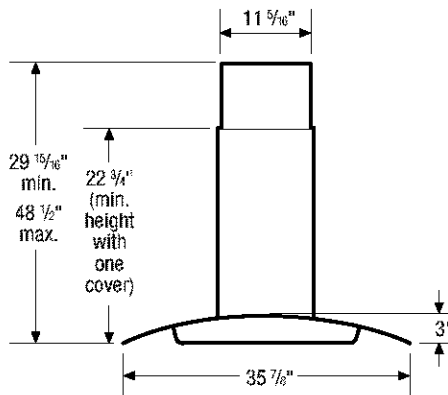

PLHV36W6CC

