

Operator's Manual

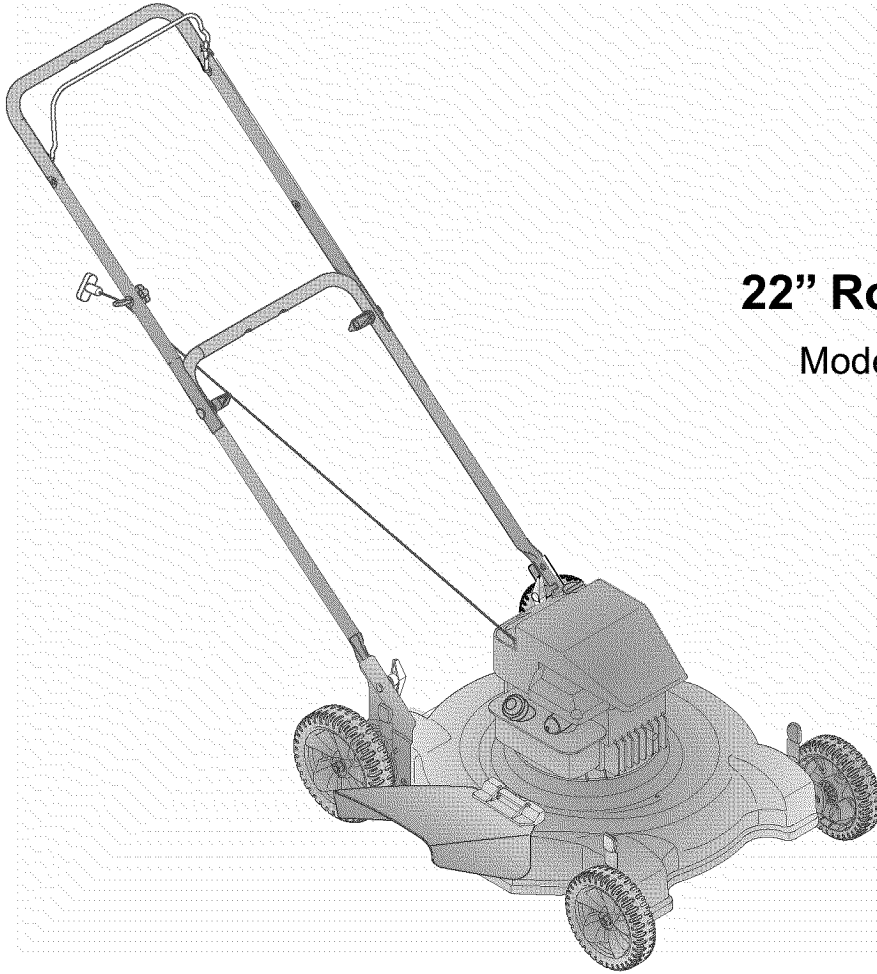

22" Rotary Mower

Model Series 080

IMPORTANT: Read safety rules and instructions carefully before operating equipment.

Warning: This unit is equipped with an internal combustion engine and should not be used on or near any unimproved forest-covered, brush-covered or grass-covered land unless the engine's exhaust system is equipped with a spark arrester meeting applicable local or state laws (if any). If a spark arrester is used, it should be maintained in effective working order by the operator. In the State of California the above is required by law (Section 4442 of the California Public Resources Code). Other states may have similar laws. Federal laws apply on federal lands. A spark arrester for the muffler is available through your nearest engine authorized service dealer or contact the service department, P.O. Box 361131 Cleveland, Ohio 44136-0019.

MTD LLC, P.O. BOX 361131 CLEVELAND, OHIO 44136-0019

PRINTED IN U.S.A.

FORM NO. 770-10342D
(10/2003)

TABLE OF CONTENTS

Content	Page	Content	Page
Customer Support	2	Making Adjustments	10
Important Safe Operation Practices	3	Maintaining Your Lawn Mower	11
Slope Gauge	5	Troubleshooting	13
Setting Up	6	Parts List	14
Operating Your Lawn Mower	8	Warranty	16

FINDING MODEL NUMBER

This Operator's Manual is an important part of your new lawn mower. It will help you assemble, prepare and maintain the unit for best performance. Please read and understand what it says.



Before you start assembling your new equipment, please locate the model plate on the equipment and copy the information from it in the space provided below. A sample model plate is also given below. You can locate the model plate by standing at the operating position and looking down at the rear of the deck. This information will be necessary to use the manufacturer's web site and/or help from the Customer Support Department or an authorized service dealer.



Copy the model number here: _____

Copy the serial number here: _____

CUSTOMER SUPPORT

Please do NOT return the unit to the retailer from which it was purchased, without first contacting Customer Support.

If you have difficulty assembling this product or have any questions regarding the controls, operation or maintenance of this unit, you can seek help from the experts. Choose from the options below:

	<p>Visit mtdproducts.com for many useful suggestions. Click on Customer Support button and you will get the four options reproduced here. Click on the appropriate button and help is immediately available.</p> <div style="text-align: center; border: 1px solid black; padding: 5px; margin: 10px auto; width: 80%;"> <p>Find Answers Click here to search our knowledge base. Search by product, keyword, or phrase.</p> <p>My Stuff Login to check the status of your questions, modify your inquiries, or update your personal profile.</p> <p>Service Locator Need local assistance? Click here to find authorized service centers in your area.</p> <p>Manuals Online Need a manual and/or parts list? Download literature from recent model years.</p> </div> <p style="text-align: center;"><i>The answer you are looking for could be just a mouse click away!</i></p>		<p><i>The answer you are looking for could be just a mouse click away!</i></p>
	<p>If you prefer to reach a Customer Support Representative, please call 1(800) 800-7310.</p>		
	<p>The engine manufacturer is responsible for all engine-related issues with regards to performance, power-rating, specifications, warranty and service. Please refer to the engine manufacturer's Owner's/Operator's Manual, packed separately with your unit, for more information.</p>		

SECTION 1: IMPORTANT SAFE OPERATION PRACTICES



WARNING: This symbol points out important safety instructions which, if not followed, could endanger the personal safety and/or property of yourself and others. Read and follow all instructions in this manual before attempting to operate this machine. Failure to comply with these instructions may result in personal injury. When you see this symbol - **heed its warning.**

WARNING: Engine Exhaust, some of its constituents, and certain vehicle components contain or emit chemicals known to State of California to cause cancer and birth defects or other reproductive harm.

DANGER: This machine was built to be operated according to the rules for safe operation in this manual. As with any type of power equipment, carelessness or error on the part of the operator can result in serious injury. This machine is capable of amputating hands and feet and throwing objects. Failure to observe the following safety instructions could result in serious injury or death.

General Operation

1. Read this operator's manual carefully in its entirety before attempting to assemble this machine. Read, understand, and follow all instructions on the machine and in the manual(s) before operation. Be completely familiar with the controls and the proper use of this machine before operating it. Keep this manual in a safe place for future and regular reference and for ordering replacement parts.
2. This machine is a precision piece of power equipment, not a plaything. Therefore, exercise extreme caution at all times. Your unit has been designed to perform one job: to mow grass. Do not use it for any other purpose.
3. Never allow children under 14 years old to operate this machine. Children 14 years old and over should read and understand the instructions in this manual and should be trained and supervised by a parent. Only responsible individuals who are familiar with these rules of safe operation should be allowed to use this machine.
4. Thoroughly inspect the area where the equipment is to be used. Remove all stones, sticks, wire, bones, toys and other foreign objects which could be tripped over or picked up and thrown by the blade. Thrown objects can cause serious personal injury. Plan your mowing pattern to avoid discharge of material toward roads, sidewalks, bystanders and the like. Also, avoid discharging material against a wall or obstruction which may cause discharged material to ricochet back toward the operator.
5. To help avoid blade contact or a thrown object injury, stay in the operator zone behind the handles and keep children, bystanders, helpers and pets at least 75 feet from the mower while it is in operation. Stop machine if anyone enters the area.
6. Always wear safety glasses or safety goggles during operation and while performing an adjustment or repair to protect your eyes. Thrown objects which ricochet can cause serious injury to the eyes.
7. Wear sturdy, rough-soled work shoes and close-fitting slacks and shirts. Shirts and pants that cover the arms and legs and steel-toed shoes are recommended. Never operate this machine in bare feet, sandals, slippery or light weight (e.g. canvas) shoes.
8. Do not put hands or feet near rotating parts or under the cutting deck. Contact with the blade can amputate hands and feet.
9. A missing or damaged discharge cover can cause blade contact or thrown object injuries.
10. Many injuries occur as a result of the mower being pulled over the foot during a fall caused by slipping or tripping. Do not hold on to the mower if you are falling; release the handle immediately.
11. Never pull the mower back toward you while you are walking. If you must back the mower away from a wall or obstruction first look down and behind to avoid tripping and then follow these steps:
 - a. Step back from the mower to fully extend your arms.
 - b. Be sure you are well balanced with sure footing.
 - c. Pull the mower back slowly, no more than half way toward you.
 - d. Repeat these steps as needed.
5. Do not operate the mower while under the influence of alcohol or drugs.
6. Do not engage the self-propelled mechanism on units so equipped while starting engine.
7. The blade control handle is a safety device. Never attempt to bypass its operation. Doing so makes the safety device inoperative and may result in personal injury through contact with the rotating blade. The blade control handle must operate easily in both directions and automatically return to the disengaged position when released.
8. Never operate the mower in wet grass. Always be sure of your footing. A slip and fall can cause serious personal injury. If you feel you are losing your footing, release the blade control handle immediately and the blade will stop rotating within three seconds.
9. Mow only in daylight or in good artificial light. Walk, never run.
10. Stop the blade when crossing gravel drives, walks or roads.
11. If the equipment should start to vibrate abnormally, stop the engine and check immediately for the cause. Vibration is generally a warning of trouble.
12. Shut the engine off and wait until the blade comes to a complete stop before removing the grass catcher or unclogging the chute. The cutting blade continues to rotate for a few seconds after the engine is shut off. Never place any part of the body in the blade area until you are sure the blade has stopped rotating.
13. Never operate mower without proper trail shield, discharge cover, grass catcher, blade control handle or other safety protective devices in place and working. Never operate mower with damaged safety devices. Failure to do so, can result in personal injury.
14. Muffler and engine become hot and can cause a burn. Do not touch.
15. Only use parts and accessories made for this machine by the manufacturer. Failure to do so can result in personal injury.
16. If situations occur which are not covered in this manual, use care and good judgment. Contact your dealer for assistance. Telephone 1-800-800-7310 for the name of your nearest dealer.

Slope Operation

Slopes are a major factor related to slip and fall accidents which can result in severe injury. Operation on slopes requires extra caution. If you feel uneasy on a slope, do not mow it. For your safety, use the slope gauge included as part of this manual to measure slopes before operating this unit on a sloped or hilly area. If the slope is greater than 15 degrees, do not mow it.

Do:

1. Mow across the face of slopes; never up and down. Exercise extreme caution when changing direction on slopes.
2. Watch for holes, ruts, rocks, hidden objects, or bumps which can cause you to slip or trip. Tall grass can hide obstacles.
3. Always be sure of your footing. A slip and fall can cause serious personal injury. If you feel you are losing your balance, release the blade control handle immediately, and the blade will stop rotating within 3 seconds.

Do Not:

1. Do not mow near drop-offs, ditches or embankments, you could lose your footing or balance.
2. Do not mow slopes greater than 15 degrees as shown on the slope gauge.
3. Do not mow on wet grass. Unstable footing could cause slipping.

Children

Tragic accidents can occur if the operator is not alert to the presence of children. Children are often attracted to the mower and the mowing activity. They do not understand the dangers. Never assume that children will remain where you last saw them.

1. Keep children out of the mowing area and under the watchful care of a responsible adult other than the operator.
2. Be alert and turn mower off if a child enters the area.
3. Before and while moving backwards, look behind and down for small children.
4. Use extreme care when approaching blind corners, doorways, shrubs, trees, or other objects that may obscure your vision of a child who may run into the mower.
5. Keep children away from hot or running engines. They can suffer burns from a hot muffler.
6. Never allow children under 14 years old to operate a power mower. Children 14 years old and over should read and understand the operation instructions and safety rules in this manual and should be trained and supervised by a parent.

Service

Safe Handling Of Gasoline:

1. To avoid personal injury or property damage use extreme care in handling gasoline. Gasoline is extremely flammable and the vapors are explosive. Serious personal injury can occur when gasoline is spilled on yourself or your clothes which can ignite.
2. Wash your skin and change clothes immediately.
3. Use only an approved gasoline container.
4. Never fill containers inside a vehicle or on a truck or trailer bed with a plastic liner. Always place containers on the ground away from your vehicle before filling.
5. Remove gas-powered equipment from the truck or trailer and refuel it on the ground. If this is not possible, then refuel such equipment on a trailer with a portable container, rather than from a gasoline dispenser nozzle.
6. Keep the nozzle in contact with the rim of the fuel tank or container opening at all times until fueling is complete. Do not use a nozzle lock-open device.
7. Extinguish all cigarettes, cigars, pipes and other sources of ignition.

8. Never fuel machine indoors because flammable vapors will accumulate in the area.
9. Never remove gas cap or add fuel while the engine is hot or running. Allow engine to cool at least two minutes before refueling.
10. Never over fill fuel tank. Fill tank to no more than ½ inch below bottom of filler neck to provide for fuel expansion.
11. Replace gasoline cap and tighten securely.
12. If gasoline is spilled, wipe it off the engine and equipment. Move unit to another area. Wait 5 minutes before starting the engine.
13. Never store the machine or fuel container near an open flame, spark or pilot light as on a water heater, space heater, furnace, clothes dryer or other gas appliances.
14. To reduce fire hazard, keep mower free of grass, leaves, or other debris build-up. Clean up oil or fuel spillage and remove any fuel soaked debris.
15. Allow a mower to cool at least 5 minutes before storing.

General Service:

1. Never run an engine indoors or in a poorly ventilated area. Engine exhaust contains carbon monoxide, an odorless and deadly gas.
2. Before cleaning, repairing, or inspecting, make certain the blade and all moving parts have stopped. Disconnect the spark plug wire and ground against the engine to prevent unintended starting.
3. Check the blade and engine mounting bolts at frequent intervals for proper tightness. Also, visually inspect blade for damage (e.g., bent, cracked, worn) Replace blade with the original equipment manufacture's (O.E.M.) blade only, listed in this manual. "Use of parts which do not meet the original equipment specifications may lead to improper performance and compromise safety!"
4. Mower blades are sharp and can cut. Wrap the blade or wear gloves, and use extra caution when servicing them.
5. Keep all nuts, bolts, and screws tight to be sure the equipment is in safe working condition.
6. Never tamper with safety devices. Check their proper operation regularly.
7. After striking a foreign object, stop the engine, disconnect the spark plug wire and ground against the engine. Thoroughly inspect the mower for any damage. Repair the damage before starting and operating the mower.
8. Never attempt to make a wheel or cutting height adjustment while the engine is running.
9. Grass catcher components, discharge cover, and trail shield are subject to wear and damage which could expose moving parts or allow objects to be thrown. For safety protection, frequently check components and replace immediately with original equipment manufacturer's (O.E.M.) parts only, listed in this manual. "Use of parts which do not meet the original equipment specifications may lead to improper performance and compromise safety!"
10. Do not change the engine governor setting or overspeed the engine. The governor controls the maximum safe operating speed of the engine.
11. Maintain or replace safety labels, as necessary.
12. Observe proper disposal laws and regulations. Improper disposal of fluids and materials can harm the environment.

Your Responsibility

- Restrict the use of this power machine to persons who read, understand and follow the warnings and instructions in this manual and on the machine.

SECTION 2: SLOPE GAUGE

Use this page as a guide to determine slopes where you may not operate safely. Do not operate your lawn mower on such slopes.

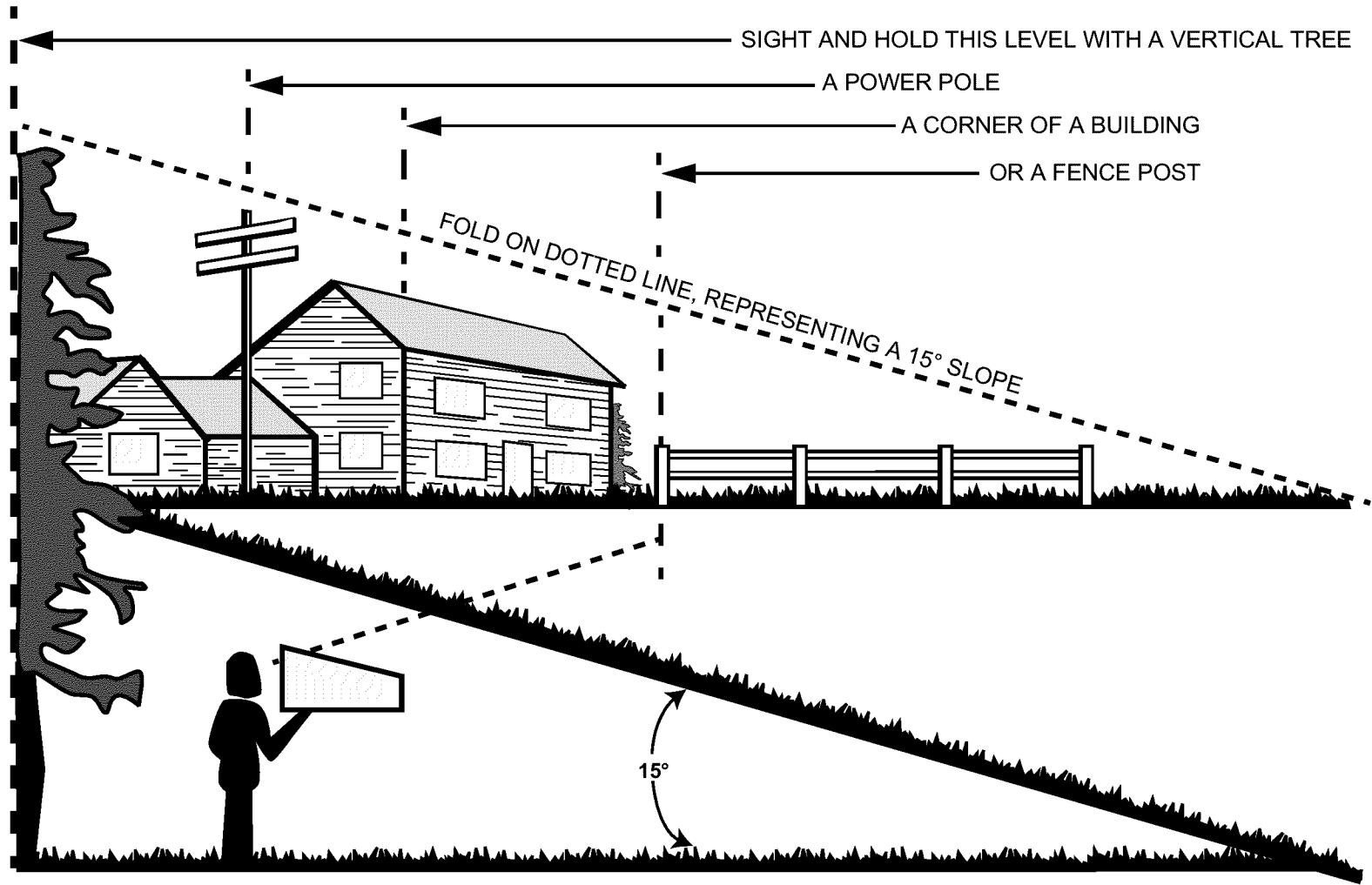

WARNING

Do not mow on inclines with a slope in excess of 15 degrees (a rise of approximately 2-1/2 feet every 10 feet). A riding mower could overturn and cause serious injury. If operating a walk-behind mower on such a slope, it is extremely difficult to maintain your footing and you could slip, resulting in serious injury.

Operate RIDING mowers up and down slopes, never across the face of slopes.

Operate WALK-BEHIND mowers across the face of slopes, never up and down slopes.

SECTION 3: SETTING UP

Spark Plug Wire

1. Disconnect spark plug wire from the spark plug, and ground it against the engine.
2. If engine is equipped with a rubber boot, attach rubber boot to a bolt on the engine to ground. See Figure 1.

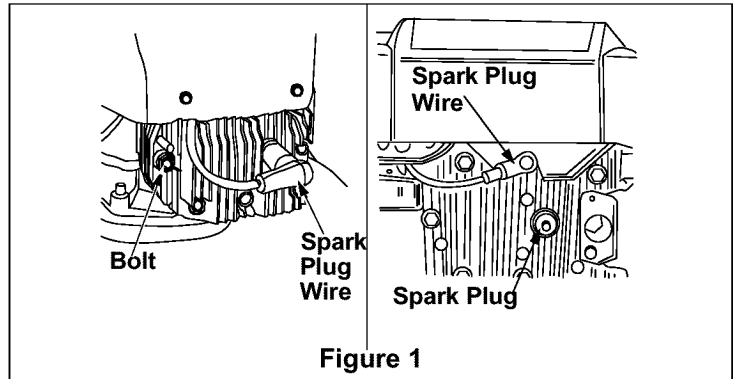

Chute Retainer

For shipping purposes, the chute deflector on your mower is held in an upright position by a retainer. Remove the retainer by following the steps below.

1. Push the chute deflector up towards the engine. Holding the deflector in this position, remove the retainer. See Figure 2. Discard the retainer.
2. Lower the chute deflector carefully keeping your fingers out of the way.

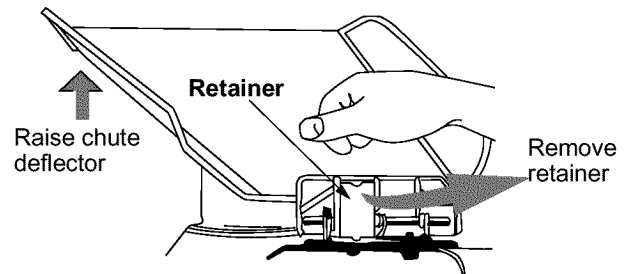

Upper & Lower Handles

1. Lift the upper handle up from position A and pull it to position B following the arrow in Figure 3. The handle should click into this position.
2. Tighten wing nut A securing the upper handle to the lower handle. Make sure that the carriage bolt is seated properly in the handle. Repeat on the other side with wing nut B. See Figure 3.
3. Tighten wing nuts C and D at the end of the lower handle to secure the handle to the handle bracket. See Figure 3.
4. Fasten the cable to the lower handle with the cable tie on the lower handle. Pull the cable tie tight and trim off the excess.

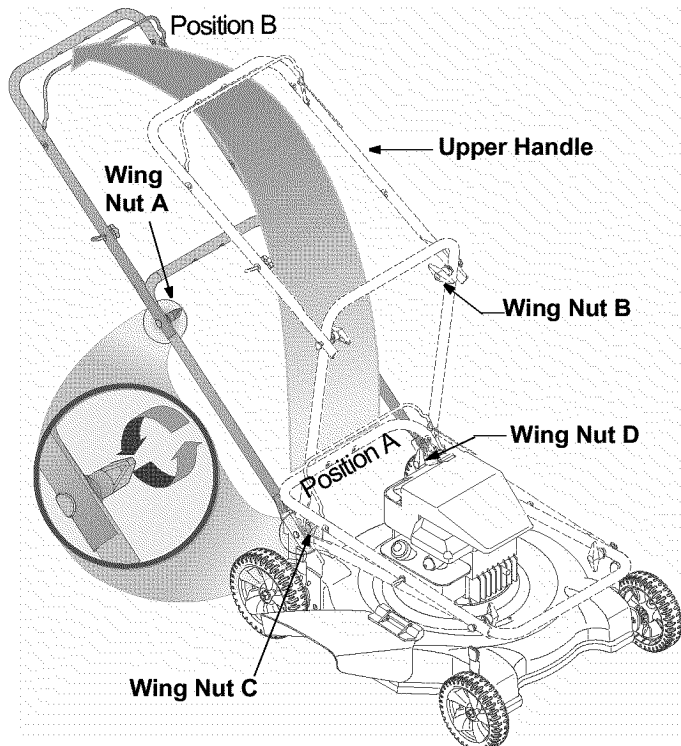

Rope Guide

1. Insert rope guide into the hole on the upper handle indicated in Figure 4. Secure with wing nut E, but do not tighten.

NOTE: Follow this step only if the rope guide is not attached to the mower. Otherwise move to step 2.

2. Hold the blade control handle against the upper handle (marked 1 in Figure 4) and pull the starter rope out of the engine (marked 2 in Figure 4).
3. Release the blade control handle. Slip the starter rope into the rope guide (marked 3 in Figure 4).
4. Tighten the wing nut E. See Figure 4.

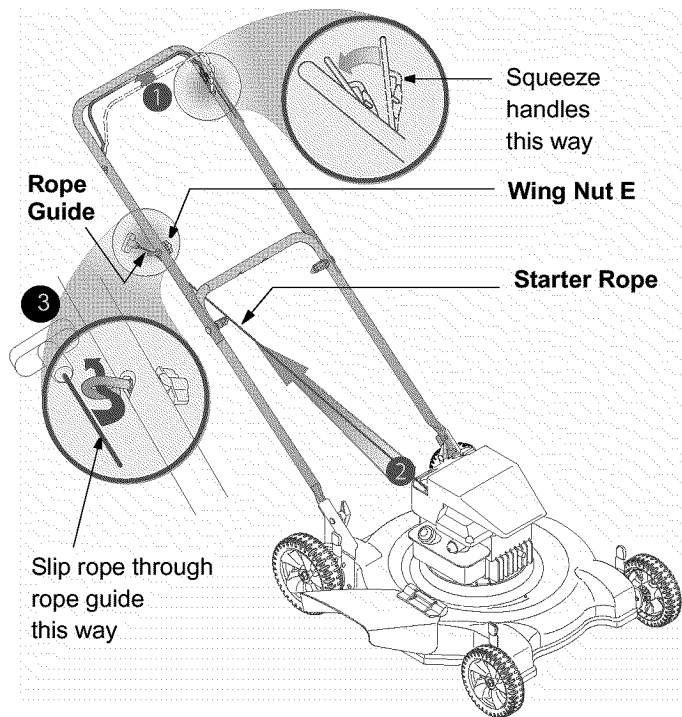

Figure 4

Mulching Baffle

If your mower is equipped with a mulching baffle, install it on the right side of the deck. Follow the sequence indicated here.

1. Lift up and hold the side-discharge chute deflector.
2. Insert bottom lip of the mulching baffle **inside** the chute opening (marked 1 in Figure 5).
3. Snap hooks of the mulching baffle over the hinge pin of the chute deflector (marked 2 in Figure 5). The hooks must snap into place on the hinge pin, locking the mulching baffle firmly onto the mower. Release the chute deflector.

NOTE: For proper assembly, install bottom lip inside chute opening **before** placing hooks over the hinge pin.

IMPORTANT: This unit is shipped without gasoline or oil in the engine. Fill up gasoline and oil as instructed in the accompanying engine manual **before** operating your mower.

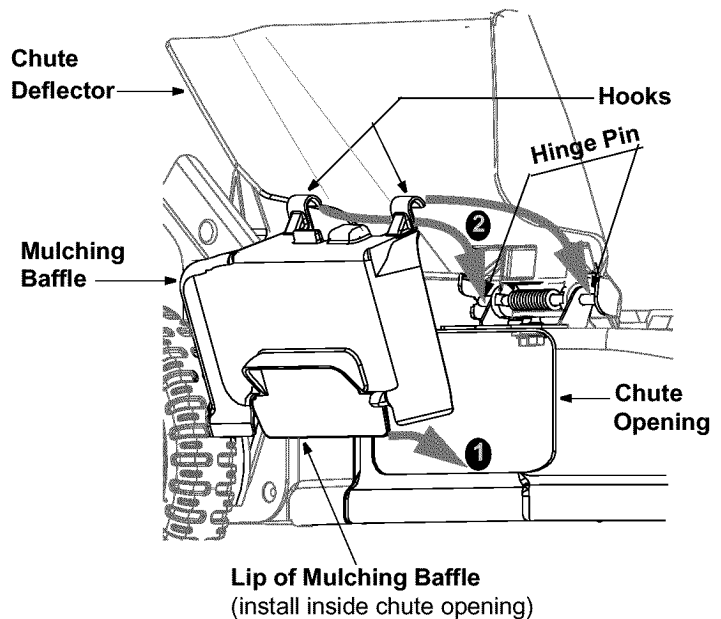

Figure 5

SECTION 4: OPERATING YOUR LAWN MOWER

Know your lawn mower

Now that you have set up your lawn mower for operation, get acquainted with its controls and features. These are described below and illustrated in Figure 6. This knowledge will allow you to use your new equipment to its fullest potential.

Blade Control Handle

The blade control handle is attached to the upper handle of the mower. Depress the blade control handle to operate the unit. Release it to stop engine and blade.



WARNING: This blade control mechanism is a safety device. Never attempt to bypass its operations.

Cutting Height Adjustment Levers

One adjustment lever is located on each wheel and is used to adjust the cutting height. All four levers have to be at the same relative position to ensure uniform cut.

Recoil Starter

The recoil starter is attached to the right upper handle. Stand behind the unit and pull the recoil starter rope to start the unit.

Mulching Baffle

The mulching baffle is used to recirculate grass clippings back to the lawn. Attach it as instructed on page 7 of this manual.

Chute Deflector/Discharge Chute

This chute discharges grass clippings beside each cutting lap. In tall grass, use this chute first to cut, and then use the mulching baffle to mulch.

Gas & Oil Fill-Up

- Check oil level and add oil if necessary. Follow engine manual for this. See Figure 6 above for location of oil fill.
- Service the engine with gasoline as instructed in the engine manual. See Figure 6 above for location of gas cap.



WARNING: Use extreme care when handling gasoline. Gasoline is extremely flammable and the vapors are explosive. Never fuel the machine indoors or while the engine is hot or running. Extinguish cigarettes, cigars, pipes and other sources of ignition.

Before Starting

- Attach spark plug wire to spark plug. Make certain the metal cap on the end of the spark plug wire (inside the rubber boot) is fastened securely over the metal tip on the spark plug.



WARNING: The operation of any lawn mower can result in foreign objects being thrown into the eyes, which can damage your eyes severely. Always wear safety glasses while operating the mower, or while performing any adjustments or repairs on it.

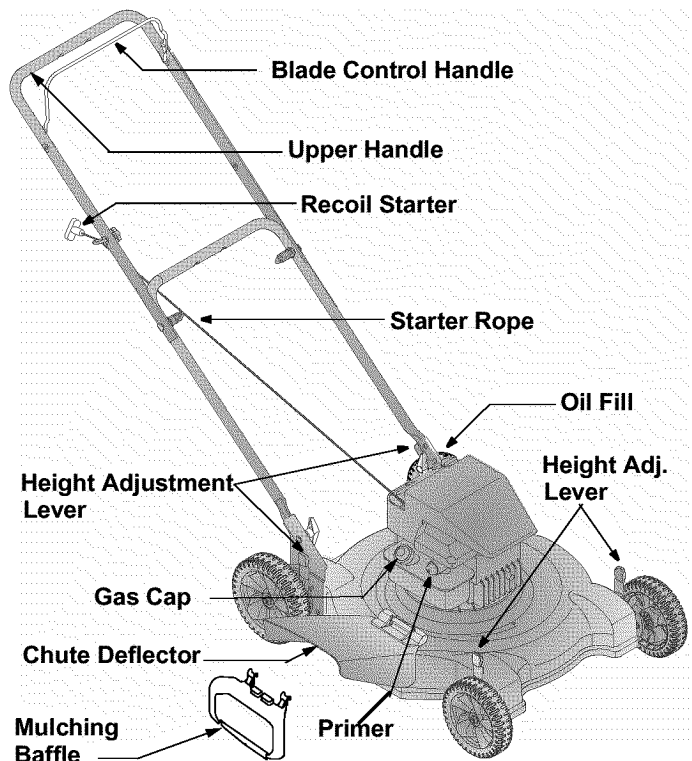

Figure 6

Starting Engine



WARNING: Be sure no one other than the operator is standing near the lawn mower while starting engine or operating mower. Never run engine indoors or in enclosed, poorly ventilated areas. Engine exhaust contains carbon monoxide, an odorless and deadly gas. Keep hands, feet, hair and loose clothing away from any moving parts on engine and lawn mower.

1. Push primer three times. Wait about two seconds between each push. See Figure 7A. In temperature around 55° F or below, prime five times. Do not prime to restart a warm engine.
2. Standing behind the mower, squeeze the blade control handle against the upper handle. See Figure 7B.
3. Holding these two handles together firmly, grasp recoil starter handle and pull rope out with a rapid, continuous, full arm stroke. See Figure 7C. Keeping a firm grip on the starter handle, let the rope rewind slowly. Repeat until engine cranks. Let the rope rewind each time slowly.

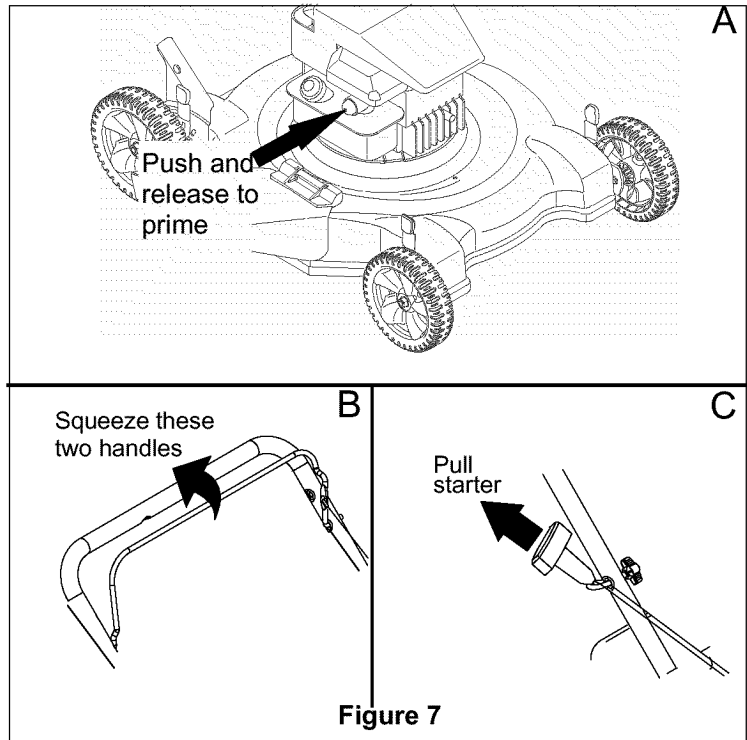

Stopping Engine

1. Release blade control handle to stop the engine and the blade.
2. Disconnect spark plug wire from spark plug and ground against the engine.

Using Your Lawn Mower

IMPORTANT: Be sure the lawn is clear of stones, sticks, wire, or other objects which could damage the lawn mower or the engine. Such objects could be accidentally thrown by the mower in any direction and cause serious personal injury to the operator and others.



WARNING: If you strike a foreign object, stop the engine. Remove wire from the spark plug, thoroughly inspect the mower for any damage, and repair the damage before restarting and operating the mower. Extensive vibration of the mower during operation is an indication of damage. The unit should be promptly inspected and repaired.

Operating Tips

- For best results, do not cut wet grass.
 - New grass, thick grass, or wet grass may require a narrower cut.
 - For a healthier lawn, never cut off more than one-third of the total length of the grass.
 - Your lawn should be cut in the fall as long as there is growth.
 - For effective mulching, do not cut wet grass.
 - Adjust ground speed according to the condition of the lawn.
 - If the grass has been allowed to grow in excess of 4 inches, mulching is not recommended. Mow using the side discharge to reduce the grass height to 3-1/4 inches or less before mulching.
-
-

SECTION 5: MAKING ADJUSTMENTS



WARNING: Always stop engine, disconnect spark plug, and ground against engine before performing adjustments.

Cutting Height

Each wheel has a height adjustment lever to change the cutting height of the mower.

1. Depress the lever towards the wheel and slide the lever assembly to desired position for a change in cutting height. See Figure 8.

IMPORTANT: All wheels must be placed in the same relative position. For rough or uneven lawns, move the height adjustment lever to a higher position. This will stop scalping of grass.

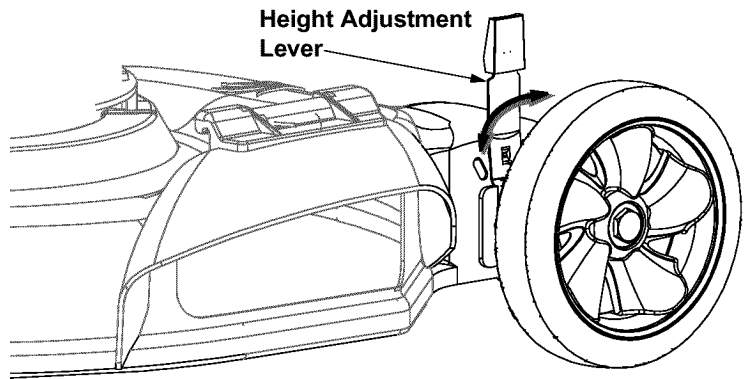

Figure 8

Handle Height

Your mower is shipped with the handle in the higher height position. For convenience of operating, you may lower the handle height as follows:

1. Remove the starter rope from the rope guide.
2. Remove the wing nuts shown in Figure 9 and remove the lower handles.
3. Position each handle bracket assembly stud into the top hole in the lower handle.

NOTE: Each end of the lower handle must be placed in the same relative position.

4. Re-attach the lower handle to the handle bracket on each side and tighten the wing nuts. Re-insert starter rope into rope guide. For instructions, refer to page 7.
- Remember to attach the spark plug wire after completing the adjustments and before operating your mower.

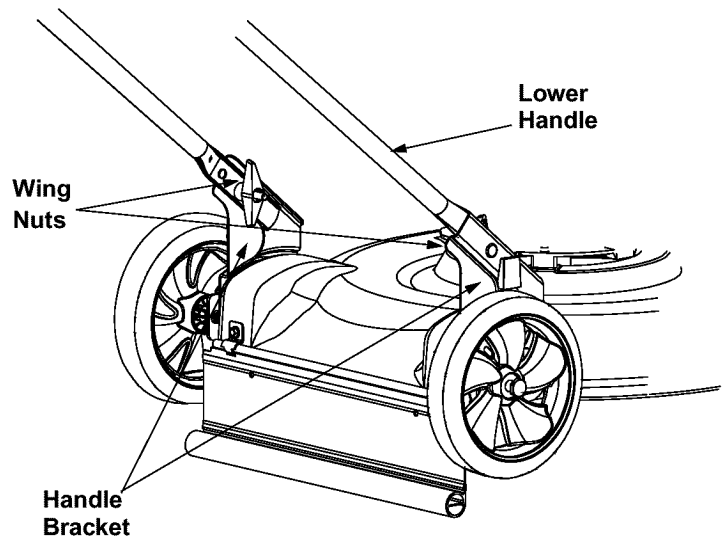

Figure 9

SECTION 6: MAINTAINING YOUR LAWN MOWER

General Recommendations

- Always observe safety rules when performing any maintenance.
- The warranty on this lawn mower does not cover items that have been subjected to operator abuse or negligence. To receive full value from the warranty, operator must maintain the lawn mower as instructed here.
- Changing of engine-governed speed will void engine warranty.
- All adjustments should be checked at least once each season.
- Periodically check all fasteners and make sure these are tight.



WARNING: Always stop engine, disconnect spark plug, and ground against engine before cleaning, lubricating or doing any kind of maintenance on your machine.

Lubrication

Blade Control Handle

- Lubricate the pivot points on the blade control handle at least once a season with light oil. The blade control must operate freely in both directions. See Figure 10.

Wheels

- Lubricate the wheels at least once a season with light oil (or motor oil). If the wheels are removed for any reason, lubricate the surface of the axle bolt and inner surface of the wheel with light oil. See Figure 10.

Chute Deflector

- Lubricate the torsion spring and pivot point periodically with light oil to prevent rust. See Figure 10.

Engine

Follow the accompanying engine manual for lubrication schedule and instruction.

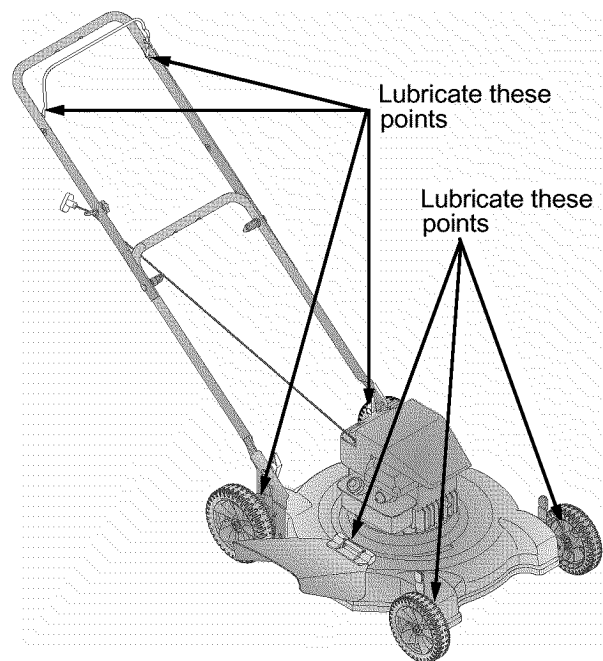

Figure 10

Cleaning Mower

- Clean underside of the mower deck after each use to prevent build-up of grass clippings or other debris. Follow the steps below for this job.

NOTE: We do not recommend the use of pressure washers or garden hose to clean your unit. These may cause damage to electric components, spindles, pulleys, bearings, or the engine. The use of water will result in shortened life and reduce serviceability.

1. Disconnect spark plug wire. Drain gasoline from the lawn mower, or place a piece of plastic under the gas cap.
2. Tip the mower so that it rests on the housing. Keep the side with the air cleaner facing up. Hold the mower firmly.



WARNING: Never tip the mower more than 90 degrees in any directions and do not leave the mower tipped for any length of time. Oil can drain into the upper part of the engine causing a starting problem.

3. Scrape and clean the underside of the deck with a suitable tool. Do *not* spray with water.
4. Put the mower back on its wheels on the ground. If you had put plastic under the gas cap earlier, make sure to remove it now.

Blade Care



WARNING: When removing the cutting blade for sharpening or replacement, protect your hands with a pair of heavy gloves or use a heavy rag to hold the blade.

- Periodically inspect the blade adapter for cracks, especially if you strike a foreign object. Replace when necessary. Follow the steps below for blade service.
1. Disconnect spark plug wire from spark plug. Turn mower on its side making sure that the air filter and the carburetor are up.
 2. Remove the bolt and the blade bell support which hold the blade and the blade adapter to the engine crankshaft. See Figure 11.
 3. Remove blade and adapter from the crankshaft.
 4. The blade can be sharpened with a file or on a grinding wheel. Do not attempt to sharpen the blade while it is still on the mower.
 5. When sharpening the blade, follow the original angle of grind. Grind each cutting edge equally to keep the blade balanced.

NOTE: Always remove blade from the adapter for testing balance.

6. Balance the blade on a round shaft screwdriver to check. Remove metal from the heavy side until it balances evenly.

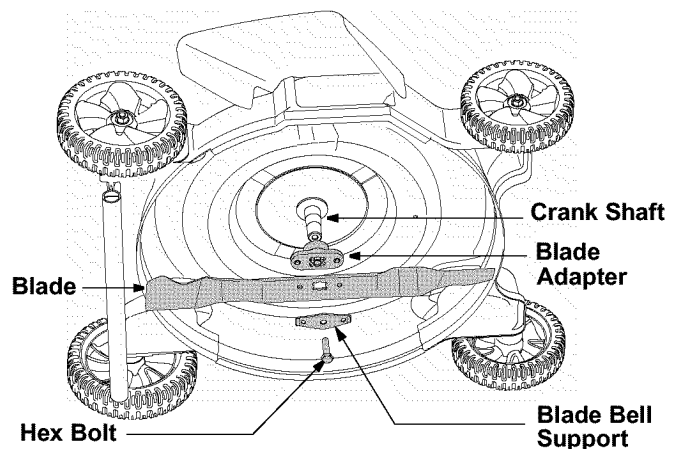

Figure 11



WARNING: An unbalanced blade will cause excessive vibration when rotating at high speeds. It may cause damage to the mower, and could break causing personal injury.

7. Lubricate the engine crankshaft and the inner surface of the blade adapter with light oil. Slide the blade adapter onto the engine crankshaft.
8. Place blade on the blade adapter. See Figure 11. Make sure that the blade is aligned and seated on blade adapter flanges.

NOTE: Place the blade on the adapter such that the side of the blade marked "Bottom" (or with part number) faces ground when the mower is in the operating position.

- Place blade bell support on the blade. Align notches on the blade bell support with small holes in the blade.
- Replace hex bolt and tighten hex bolt to torque: 450 in. lbs. min., 600 in. lbs. max.

IMPORTANT: To ensure safe operation of your mower, periodically check the blade bolt for correct torque.

Off-Season Storage

The following steps should be taken to prepare your lawn mower for storage.

- Clean and lubricate mower thoroughly as described in the lubrication instructions.

IMPORTANT: We do not recommend the use of a pressure washer or garden hose to clean your unit.

- Refer to engine manual for correct engine storage instructions.
- Coat mower's cutting blade with chassis grease to prevent rusting.
- Store mower in a dry, clean area. Do not store next to corrosive materials, such as fertilizer.

NOTE: When storing any type of power equipment in a poorly ventilated or metal storage shed, care should be taken to rust-proof the equipment. Using a light oil or silicone, coat the equipment, especially cables and all moving parts of your lawn mower before storage.

SECTION 7: TROUBLESHOOTING

Problem	Cause	Remedy
Engine fails to start	<ol style="list-style-type: none"> 1. Blade control handle disengaged. 2. Spark plug wire disconnected. 3. Fuel tank empty or stale fuel. 4. Blocked fuel line. 5. Faulty spark plug. 6. Engine flooded 	<ol style="list-style-type: none"> 1. Engage blade control handle. 2. Connect wire to spark plug. 3. Fill tank with clean, fresh gasoline. 4. Clean fuel line. 5. Clean, adjust gap, or replace. 6. Wait a few minutes to restart, but do not prime.
Engine runs erratic	<ol style="list-style-type: none"> 1. Spark plug wire loose. 2. Blocked fuel line or stale fuel. 3. Vent in gas plugged. 4. Water or dirt in fuel system. 5. Dirty air cleaner. 6. Carburetor out of adjustment. 	<ol style="list-style-type: none"> 1. Connect and tighten spark plug wire. 2. Clean fuel line; fill tank with clean, fresh gasoline 3. Clear vent. 4. Drain fuel tank. Refill with fresh fuel. 5. Clean air cleaner. 6. Adjust carburetor.
Engine overheats	<ol style="list-style-type: none"> 1. Engine oil level low. 2. Air flow restricted. 3. Carburetor not adjusted properly. 	<ol style="list-style-type: none"> 1. Fill crankcase with proper oil. 2. Remove blower housing and clean. 3. Adjust carburetor.
Occasional skip (hesitates) at high speed	<ol style="list-style-type: none"> 1. Spark plug gap too close. 	<ol style="list-style-type: none"> 1. Adjust gap to .030".
Idles poorly	<ol style="list-style-type: none"> 1. Spark plug fouled, faulty or gap too wide. 2. Carburetor improperly adjusted. 3. Dirty air cleaner. 	<ol style="list-style-type: none"> 1. Reset gap to .030" or replace spark plug. 2. Adjust carburetor. 3. Service air cleaner.
Excessive vibration	<ol style="list-style-type: none"> 1. Cutting blade loose or unbalanced. 2. Bent cutting blade. 	<ol style="list-style-type: none"> 1. Tighten blade and adapter. Balance blade. 2. Replace blade.
Mower will not mulch grass	<ol style="list-style-type: none"> 1. Wet grass. 2. Excessively high grass. 3. Dull blade. 	<ol style="list-style-type: none"> 1. Do not mow when grass is wet; wait until later to cut. 2. Mow once at a high cutting height, then mow again at desired height or make a narrower cutting path. 3. Sharpen or replace blade.
Uneven cut	<ol style="list-style-type: none"> 1. Wheels not positioned correctly. 2. Dull blade. 	<ol style="list-style-type: none"> 1. Place all four wheels in same height position. 2. Sharpen or replace blade.

NOTE: For repairs beyond the minor adjustments listed above, contact an authorized service dealer.

SECTION 8: PARTS LIST FOR SERIES 080

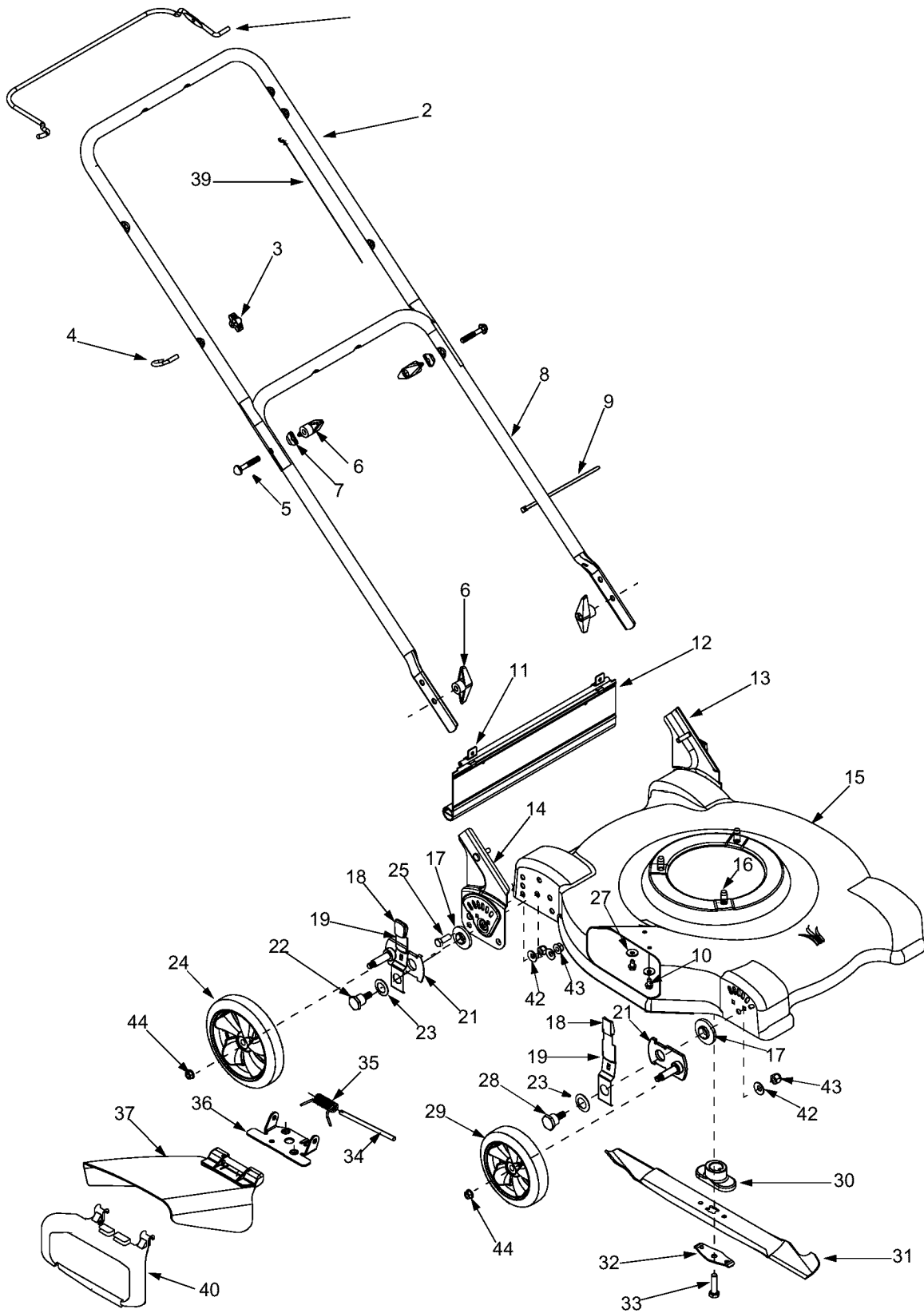

Series 080

Ref. No.	Part No.	Part Description	Ref. No.	Part No.	Part Description
1.	747-1161A	Blade Control Handle	23.	736-0741	Bell Washer .760 ID x 1.25 OD
2.	749-1092A	Upper Handle	24.	734-1987	Rear Wheel 8 x 1.8
3.	720-0279	Wing Nut	25.	710-0514	Hex Cap Screw 3/8-16 x 1.0
4.	710-1205	Eye Bolt	27.	736-0270	Bell Washer .265 ID x .75 OD
5.	710-1174	Carriage Bolt 5/16-18 x 2.0	28.	738-1172	Shoulder Screw
6.	720-0284	Wing Nut	29.	734-1988	Front Wheel 7 x 1.8
7.	736-0451	Shoulder Washer .320 ID x .93 OD	30.	748-0376C	Blade Adapter
8.	749-04037	Lower Handle	31.	742-0642A	Standard Blade 22"
9.	725-0157	Cable Tie		742-0742A	Mulching Blade 22"
10.	710-0599	TT Screw 1/4-20 x 0.5"	32.	736-0524A	Blade Bell Support
11.	17098	Hinge Clip	33.	710-1044	Hex Cap Screw 3/8-24 x 1.5
12.	731-04019	Trail Shield	34.	747-0710	Hinge Pin
13.	682-3065	Handle Bracket Assembly LH	35.	732-1014	Torsion Spring
14.	682-3064	Handle Bracket Assembly RH	36.	731-1035B	Chute Hinge
15.	687-02045	Deck Assembly 22" (with logo)	37.	731-1034B	Hinged Chute Deflector
	687-02048	Deck Assembly 22" (no logo)	39.	746-0957	Blade Control Cable - 37.25"
16.	710-0654A	TT Screw 3/8-16 x 1.0		746-1130	Blade Control Cable - 40"
17.	741-0751	Height Adjuster Bearing		746-1091	Blade Control Cable - 50"
18.	720-0426	Height Adjuster Knob	40.	731-04197	Mulching Plug (if equipped)
19.	687-02051	Lever Assembly (includes Ref. #18)	42.	736-0105	Washer Spacer .401 ID x .870 OD
20.	710-0216	Hex Cap Screw 3/8-16 x .75	43.	712-0130	Hex Lock Nut 3/8-16
21.	687-02094	Pivot Arm	44.	712-0431	Lock Nut 3/8-16
22.	738-1173	Shoulder Screw			

MANUFACTURER'S LIMITED WARRANTY FOR:



The limited warranty set forth below is given by MTD LLC with respect to new merchandise purchased and used in the United States, its possessions and territories.

"MTD" warrants this product against defects in material and workmanship for a period of two (2) years commencing on the date of original purchase and will, at its option, repair or replace, free of charge, any part found to be defective in materials or workmanship. This limited warranty shall only apply if this product has been operated and maintained in accordance with the Operator's Manual furnished with the product, and has not been subject to misuse, abuse, commercial use, neglect, accident, improper maintenance, alteration, vandalism, theft, fire, water, or damage because of other peril or natural disaster. Damage resulting from the installation or use of any part, accessory or attachment not approved by MTD for use with the product(s) covered by this manual will void your warranty as to any resulting damage.

Normal wear parts or components thereof are subject to separate terms as follows: All normal wear parts or component failures will be covered on the product for a period of 30 days regardless of cause. After 30 days, but within the two year period, normal wear part failures will be covered ONLY IF caused by defects in materials or workmanship of OTHER component parts. Normal wear parts and components include, but are not limited to: batteries, belts, blades, blade adapters, grass bags, rider deck wheels, seats, snow thrower skid shoes, shave plates, auger spiral rubber, and tires.

HOW TO OBTAIN SERVICE: Warranty service is available, WITH PROOF OF PURCHASE, through your local authorized service dealer. To locate the dealer in your area, check your Yellow Pages, or contact MTD LLC at P.O. Box 361131, Cleveland, Ohio 44136-0019, or call 1-800-800-7310 or 1-330-220-4683 or log on to our Web site at www.mtdproducts.com.

This limited warranty does not provide coverage in the following cases:

- a. The engine or component parts thereof. These items may carry a separate manufacturer's warranty. Refer to applicable manufacturer's warranty for terms and conditions.
- b. Log splitter pumps, valves, and cylinders have a separate one year warranty.
- c. Routine maintenance items such as lubricants, filters, blade sharpening, tune-ups, brake adjustments, clutch adjustments, deck adjustments, and normal deterioration of the exterior finish due to use or exposure.

- d. MTD does not extend any warranty for products sold or exported outside of the United States, its possessions and territories, except those sold through MTD's authorized channels of export distribution.
- e. Replacement parts that are not genuine MTD parts.
- f. Service completed by someone other than an authorized service dealer.
- g. Transportation charges and service calls.

No implied warranty, including any implied warranty of merchantability of fitness for a particular purpose, applies after the applicable period of express written warranty above as to the parts as identified. No other express warranty, whether written or oral, except as mentioned above, given by any person or entity, including a dealer or retailer, with respect to any product, shall bind MTD. During the period of the warranty, the exclusive remedy is repair or replacement of the product as set forth above.

The provisions as set forth in this warranty provide the sole and exclusive remedy arising from the sale. MTD shall not be liable for incidental or consequential loss or damage including, without limitation, expenses incurred for substitute or replacement lawn care services or for rental expenses to temporarily replace a warranted product.

Some states do not allow the exclusion or limitation of incidental or consequential damages, or limitations on how long an implied warranty lasts, so the above exclusions or limitations may not apply to you.

In no event shall recovery of any kind be greater than the amount of the purchase price of the product sold. **Alteration of safety features of the product shall void this warranty.** You assume the risk and liability for loss, damage, or injury to you and your property and/or to others and their property arising out of the misuse or inability to use the product.

This limited warranty shall not extend to anyone other than the original purchaser or to the person for whom it was purchased as a gift.

HOW STATE LAW RELATES TO THIS WARRANTY: This limited warranty gives you specific legal rights, and you may also have other rights which vary from state to state.

IMPORTANT: Owner must present Original Proof of Purchase to obtain warranty coverage.