

# Operator's Manual



## 21" Self Propelled Mulching Mower

Model 559

**IMPORTANT:** Read safety rules and instructions carefully before operating equipment.

**Warning:** This unit is equipped with an internal combustion engine and should not be used on or near any unimproved forest-covered, brush-covered or grass-covered land unless the engine's exhaust system is equipped with a spark arrester meeting applicable local or state laws (if any). If a spark arrester is used, it should be maintained in effective working order by the operator. In the State of California the above is required by law (Section 4442 of the California Public Resources Code). Other states may have similar laws. Federal laws apply on federal lands. A spark arrester for the muffler is available through your nearest engine authorized service dealer or contact the service department, P.O. Box 361131 Cleveland, Ohio 44136-0019.

**MTD LLC, P.O. BOX 361131 CLEVELAND, OHIO 44136-0019**

## TABLE OF CONTENTS

Content	Page
Important Safe Operation Practices.....	3
Slope Gauge.....	6
Assembling Your Lawn Mower.....	7
Know Your Lawn Mower.....	9
Operating Your Lawn Mower.....	10
Maintaining Your Lawn Mower.....	11
Servicing Your Lawn Mower.....	12
Off-Season Storage.....	14
Troubleshooting.....	15
Parts List.....	16

## FINDING MODEL NUMBER

This Operator's Manual is an important part of your new Lawn Mower. It will help you assemble, prepare and maintain the unit for best performance. Please read and understand what it says.



**Before you start assembling your new equipment**, please locate the model plate on the equipment and copy the information from it in the space provided below. The information on the model plate is very important if you need help from our Customer Support Department or an authorized dealer.

- You can locate the model number by standing behind the unit in the operating position and looking down at the cutting deck. A sample model plate is explained below. For future reference, please copy the model number and the serial number of the equipment in the space below.

(Model Number)	(Serial Number)

Copy the model number here: \_\_\_\_\_

Copy the serial number here: \_\_\_\_\_

## ENGINE INFORMATION

The engine manufacturer is responsible for all engine-related issues with regards to performance, power-rating, specifications, warranty and service. Please refer to the engine manufacturer's Owner's/Operator's Manual packed separately with your unit for more information.

## CALLING CUSTOMER SUPPORT



If you have difficulty assembling this product or have any questions regarding the controls, operation or maintenance of this unit, please call the Customer Support Department. Call **1- (330) 220-4MTD (4683)** or **1- (800)-800-7310** to reach a Customer Support representative. Please have your unit's model number and serial number ready when you call. See previous section to locate this information. You will be asked to enter the serial number in order to process your call .

For more details about your unit, visit our website at [www.yardman.com](http://www.yardman.com)

---

## SECTION 1: IMPORTANT SAFE OPERATION PRACTICES



**WARNING:** This symbol points out important safety instructions which, if not followed, could endanger the personal safety and/or property of yourself and others. Read and follow all instructions in this manual before attempting to operate this machine. Failure to comply with these instructions may result in personal injury. When you see this symbol—HEED ITS WARNING.

**WARNING:** Engine exhaust, some of its constituents, and certain vehicle components contain or emit chemicals known to State of California to cause cancer and birth defects or other reproductive harm.

**WARNING:** This machine was built to be operated according to the rules for safe operation in this manual. As with any type of power equipment, carelessness or error on the part of the operator can result in serious injury. This machine is capable of amputating hands and feet and throwing objects. Failure to observe the following safety instructions could result in serious injury or death.

### General Operation

1. Read this operator's manual carefully in its entirety before attempting to assemble this machine. Read, understand, and follow all instructions on the machine and in the manual(s) before operation. Be completely familiar with the controls and the proper use of this machine before operating it. Keep this manual in a safe place for future and regular reference and for ordering replacement parts.
2. This machine is a precision piece of power equipment, not a plaything. Therefore, exercise extreme caution at all times. Your unit has been designed to perform one job: to mow grass. Do not use it for any other purpose.
3. Never allow children under 14 years old to operate this machine. Children 14 years old and over should read and understand the operation instructions and safety rules in this manual and should be trained and supervised by a parent. Only responsible individuals who are familiar with these safe operation rules should use this machine.
4. Thoroughly inspect the area where equipment is to be used. Remove all stones, sticks, wire, bones, toys and other foreign objects which could be tripped over or picked up and thrown by the blade. Thrown objects can cause serious personal injury. Plan your mowing pattern to avoid discharge of material toward roads, sidewalks, bystanders and the like. Also, avoid discharging material against a wall or obstruction which may cause discharged material to ricochet back toward the operator.
5. To help avoid blade contact or a thrown object injury, stay in the operator zone behind the handles and keep bystanders, helpers, children and pets at least 75 feet from the machine while it is in operation. Stop machine if anyone enters the area.
6. Always wear safety glasses to protect your eyes during equipment operation and while performing an adjustment or repair. Thrown objects which ricochet can cause serious injury to the eyes.
7. Wear sturdy, rough-soled work shoes and close-fitting slacks and shirts. Shirts and pants that cover the arms and legs and steel-toed shoes are recommended. Never operate this machine in bare feet, sandals, slippery or light weight (e.g. canvas) shoes.
8. Do not put hands or feet near rotating parts or under the cutting deck. Contact with the blade can amputate hands and feet.
9. A missing or damaged discharge cover can cause blade contact or thrown object injuries.
10. Many injuries occur as a result of the mower being pulled over the foot during a fall caused by slipping or tripping. Do not hold on to the mower if you are falling; release the handle immediately.
11. Never pull the mower back toward you while you are walking. If you must back the mower away from a wall or obstruction first look down and behind to avoid tripping and then follow these steps:
  - a. Step back from the mower to fully extend your arms.
  - b. Be sure you are well balanced with sure footing.
  - c. Pull the mower back slowly, no more than half way toward you.
  - d. Repeat these steps as needed.
5. Do not operate the mower while under the influence of alcohol or drugs.
6. Do not engage the self-propelled mechanism on units so equipped while starting engine.
7. The blade control handle is a safety device. Never attempt to bypass its operation. Doing so makes the safety device inoperative and may result in personal injury through contact with the rotating blade. The blade control handle must operate easily in both directions and automatically return to the disengaged position when released.
8. Never operate the mower in wet grass. Always be sure of your footing. A slip and fall can cause serious personal injury. If you feel you are losing

- your footing, release the blade control handle immediately and the blade will stop rotating within three seconds.
9. Mow in daylight or good artificial light; walk, not run.
  10. Stop the blade when crossing gravel drives, walkways or roads.
  11. If the equipment should start to vibrate abnormally, stop the engine and check immediately for the cause. Vibration is generally a warning of trouble.
  12. Shut the engine off and wait until the blade comes to a complete stop before removing the grass catcher or unclogging the chute. The cutting blade continues to rotate for a few seconds after the engine is shut off. Never place any part of the body in the blade area until you are sure the blade has stopped rotating.
  13. Never operate mower without proper trail shield, discharge cover, grass catcher, blade control handle or other safety protective devices in place and working. Never operate mower with damaged safety devices. Failure to do so can result in personal injury.
  14. Muffler and engine become hot and can cause a burn. Do not touch.
  15. Only use parts and accessories made by the original equipment manufacturer (O.E.M). Failure to do so can result in personal injury.
  16. If situations occur which are not covered in this manual, use care and good judgment. Contact your dealer for assistance. Telephone 1-800-800-7310 for the name of your nearest dealer.

## Slope Operation

Slopes are a major factor related to slip and fall accidents which can result in severe injury. Operation on slopes requires extra caution. If you feel uneasy on a slope, do not mow it. Before operating this unit on a slope or hilly area, use the slope gauge on page 6 to measure slopes. If the slope is greater than 15 degrees, do not mow it.

### Do:

1. Mow across the face of slopes; never up and down. Exercise caution when changing direction.
2. Watch for holes, ruts, rocks, hidden objects, or bumps which can cause you to slip or trip. Tall grass can hide obstacles.
3. Always be sure of your footing. A slip and fall can cause serious personal injury. If you feel you are losing your balance, release the blade control handle immediately, and the blade will stop rotating within 3 seconds.

### Do Not:

1. Do not mow near drop-offs, ditches or embankments, you could lose your footing or balance.

2. Do not mow slopes greater than 15 degrees as shown on the slope gauge.
3. Do not mow on wet grass. Unstable footing could cause slipping.

## Children

Tragic accidents can occur if the operator is not alert to the presence of children. Children are often attracted to the mower and the mowing activity. They do not understand the dangers. Never assume that children will remain where you last saw them.

1. Keep children out of the mowing area and under the watchful care of a responsible adult other than the operator.
2. Be alert and turn mower off if a child enters the area.
3. Before and while moving backwards, look behind and down for small children.
4. Use extreme care when approaching blind corners, doorways, shrubs, trees, or other objects that may obscure your vision of a child who may run into the mower.
5. Keep children away from hot or running engines. They can suffer burns from a hot muffler.
6. Never allow children under 14 years old to operate a power mower. Children 14 years old and over should read and understand the operation instructions and safety rules in this manual and should be trained and supervised by a parent.

## Service

### Safe Handling of Gasoline:

1. To avoid personal injury or property damage use extreme care in handling gasoline. Gasoline is extremely flammable and the vapors are explosive. Serious personal injury can occur when gasoline is spilled on yourself or your clothes which can ignite.
2. Wash your skin and change clothes immediately.
3. Use only an approved gasoline container.
4. Never fill containers inside a vehicle or on a truck or trailer bed with a plastic liner. Always place containers on the ground away from your vehicle before filling.
5. If possible, remove gas-powered equipment from the truck or trailer and refuel it on the ground. If this is not possible, then refuel such equipment on a trailer with a portable container, rather than from a gasoline dispenser nozzle.
6. Keep the nozzle in contact with the rim of the fuel tank or container opening at all times until fueling is complete. Do not use a nozzle lock-open device.
7. Extinguish all cigarettes, cigars, pipes and other sources of ignition.
8. Never fuel machine indoors because flammable vapors will accumulate in the area.

9. Never remove gas cap or add fuel while the engine is hot or running. Allow engine to cool at least two minutes before refueling.
10. Never over fill fuel tank. Fill tank to no more than ½ inch below bottom of filler neck to provide space for fuel expansion.
11. Replace gasoline cap and tighten securely.
12. If gasoline is spilled, wipe it off the engine and equipment. Move unit to another area. Wait 5 minutes before starting the engine.
13. Never store the machine or fuel container inside where there is an open flame, spark or pilot light as on a water heater, space heater, furnace, clothes dryer or other gas appliances.
14. To reduce fire hazard, keep mower free of grass, leaves, or other debris build-up. Clean up oil or fuel spillage and remove any fuel soaked debris.
15. Allow a mower to cool at least 5 minutes before storing.

**General Service:**

1. Never run an engine indoors or in a poorly ventilated area. Engine exhaust contains carbon monoxide, an odorless and deadly gas.
2. Before cleaning, repairing, or inspecting, make certain the blade and all moving parts have stopped. Disconnect the spark plug wire and ground against the engine to prevent unintended starting.
3. Check the blade and engine mounting bolts at frequent intervals for proper tightness. Also, visually inspect blade for damage (e.g., bent, cracked, worn) Replace blade with the original equipment manufacturer's (O.E.M.) blade only, listed in this manual. "Use of parts which do not meet the original equipment specifications may

lead to improper performance and compromise safety!"

4. Mower blades are sharp and can cut. Wrap the blade or wear gloves, and use extra caution when servicing them.
5. Keep all nuts, bolts, and screws tight to be sure the equipment is in safe working condition.
6. Never tamper with safety devices. Check their proper operation regularly.
7. After striking a foreign object, stop the engine, disconnect the spark plug wire and ground against the engine. Thoroughly inspect the mower for any damage. Repair the damage before starting and operating the mower.
8. Never attempt to make a wheel or cutting height adjustment while the engine is running.
9. Grass catcher components, discharge cover, and trail shield are subject to wear and damage which could expose moving parts or allow objects to be thrown. For safety protection, frequently check components and replace immediately with original equipment manufacturer's (O.E.M.) parts only, listed in this manual. "Use of parts which do not meet the original equipment specifications may lead to improper performance and compromise safety!"
10. Do not change the engine governor setting or overspeed the engine. The governor controls the maximum safe operating speed of the engine.
11. Maintain or replace safety and instruction labels, as necessary.
12. Observe proper disposal laws and regulations. Improper disposal of fluids and materials can harm the environment.

**Your Responsibility**

- Restrict the use of this power machine to persons who read, understand and follow the warnings and instructions in this manual and on the machine.



## SECTION 2: SLOPE GAUGE

Use this page as a guide to determine slopes where you may not operate safely.

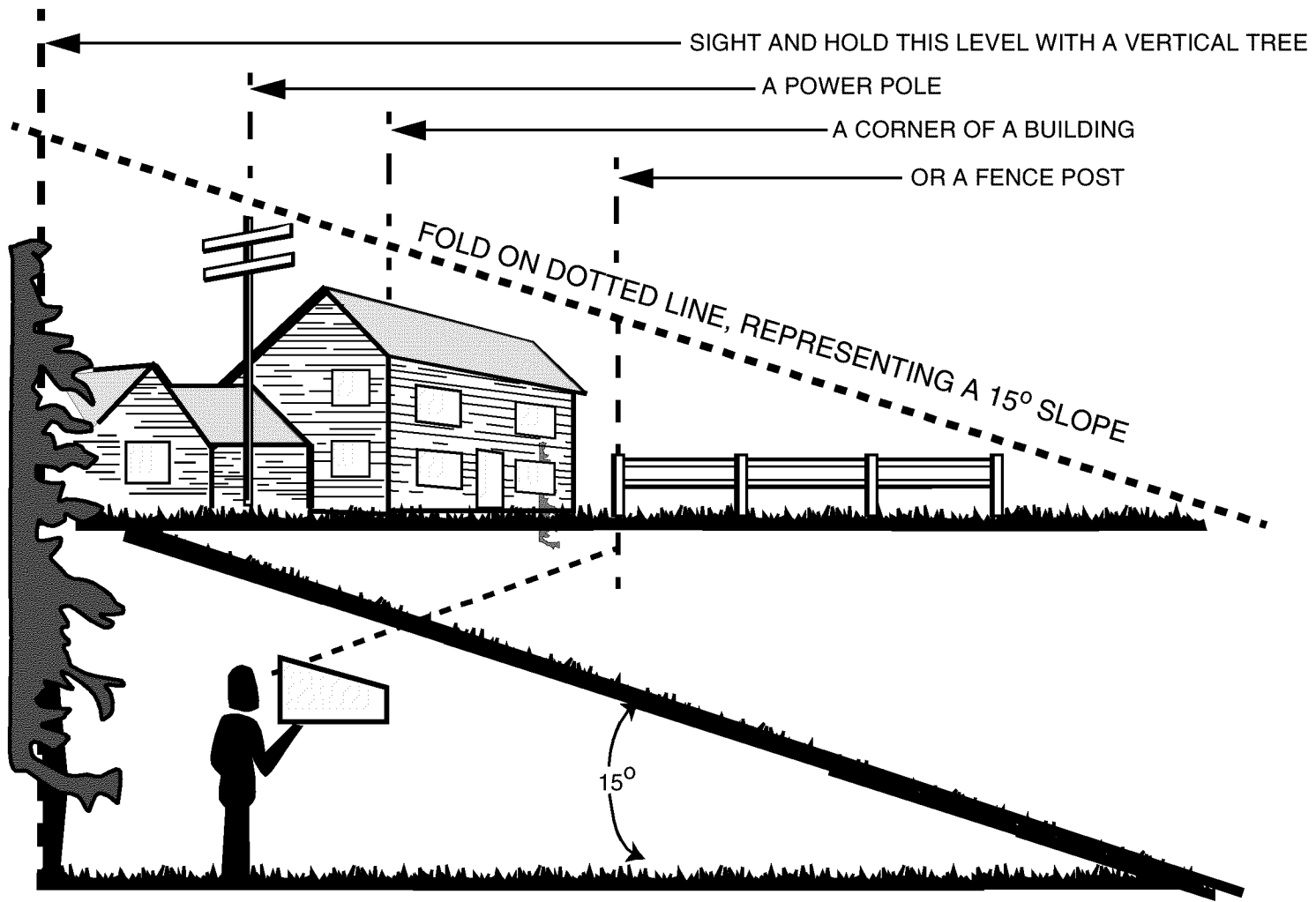

**WARNING**

Do not mow on inclines with a slope in excess of 15 degrees (a rise of approximately 2-1/2 feet every 10 feet). A riding mower could overturn and cause serious injury. If operating a walk-behind mower on such a slope, it is extremely difficult to maintain your footing and you could slip, resulting in serious injury.

Operate RIDING mowers up and down slopes, never across the face of slopes.

## SECTION 3: ASSEMBLING YOUR LAWN MOWER

### Removing Unit From Carton

- Remove staples, break glue on top flaps, or cut tape at carton end and peel along top flap to open.
- Remove loose parts included with unit (i.e., operator's manual, oil, etc.).
- Cut corners and lay carton down flat. Remove packing material.
- Roll or slide unit out of carton. Check carton thoroughly for loose parts.

**NOTE:** Make sure not to crimp cables while removing loose parts or the entire unit from the carton.

### Tools Required

- Pair of Pliers
- Funnel
- Set of adjustable wrenches

**NOTE:** Reference to right or left hand side of the mower and/or front or behind the mower is observed from the operating position.

### Hardware Pack

Please identify each piece of the hardware pack as shown in Figure 1 .

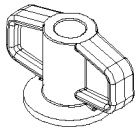

**Wing Nut**  
1/4-20 (2)

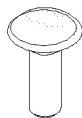

**Carriage Bolt**  
1/4-20 (2)

**Figure 1**

### Disconnecting Spark Plug

- Before setting up your lawn mower, disconnect the spark plug wire from the spark plug, and ground it against the engine. See Figure 2 .
- Attach the spark plug wire to a bolt on the engine to ground it.

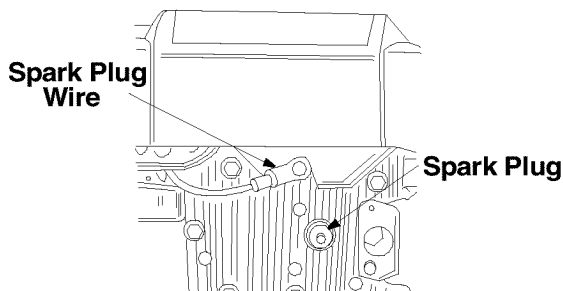

**Figure 2**

### Assembling Handle

- Remove grass bag from the unit and set it out of the way. See Figure 3 (step 1).
- Remove any packing material which may be between the upper and lower handles for shipping purposes.

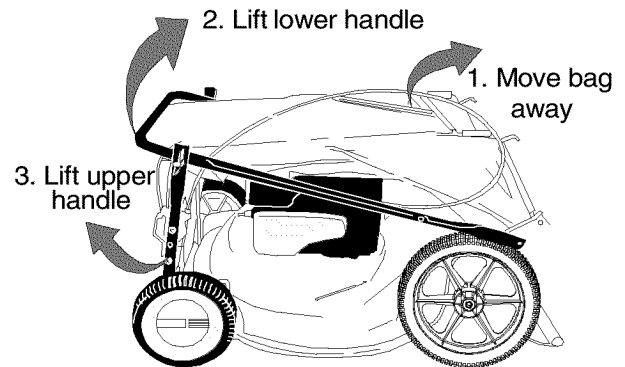

**Figure 3**

- Raise the lower handle in the direction shown in Figure 3 (step 2) till it snaps into place.
- Raise the upper handle in the direction shown in Figure 3 (step 3). Tighten the wing nuts which are already on the handle. See Figure 4 .

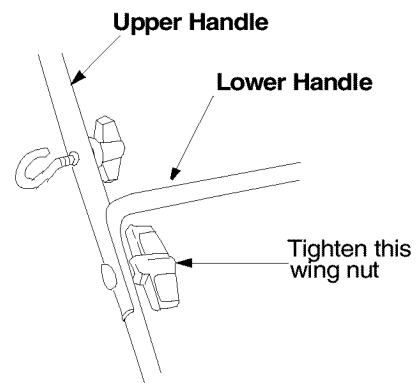

**Figure 4**

**NOTE:** Make sure to route the cables inside the lower handle. Also do not crimp the cables while lifting the handle up.

- For shipping purposes, the hairpin clip is placed in the outer hole of the weld pin on the lower handle. Remove the hairpin clip from the outer hole of the weld pin.

- Using a pair of pliers, insert the hairpin clip into the inner hole on the weld pin. Repeat on other side. See Figure 5 .

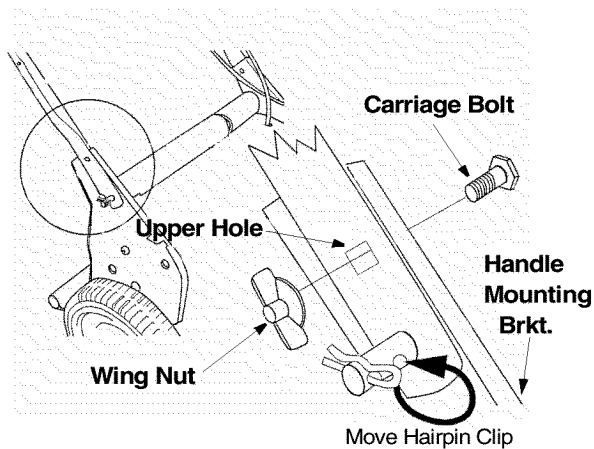

Figure 5

- After you have moved the hairpin clip, install the carriage bolt, (carriage bolt must go to the inside of handle) included in the hardware pack, in the upper hole on the handle mounting bracket. Secure with one plastic wing nut, also included in the hardware pack. Repeat process on other side.
- Attach cables to the lower handle with the two cable ties already on the lower handle, insert pegs on cable ties into the holes on the lower handle. Pull cable ties tight and cut off the extra. See Figure 6 .

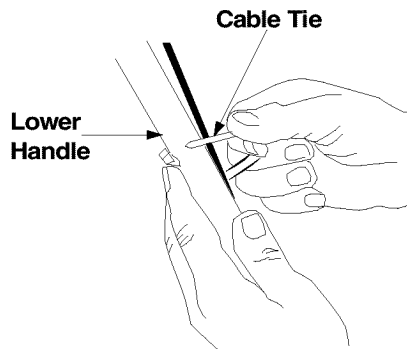

Figure 6

## Attaching Starter Rope

The rope guide is already attached to the right side of the upper handle of your mower. See Figure 7 .

- With the spark plug wire disconnected and grounded, hold the blade control handle against the upper handle, and pull the starter rope out of the engine.
- Slip the rope through the rope guide as shown below. Tighten the wing nut holding the rope guide to the upper handle.

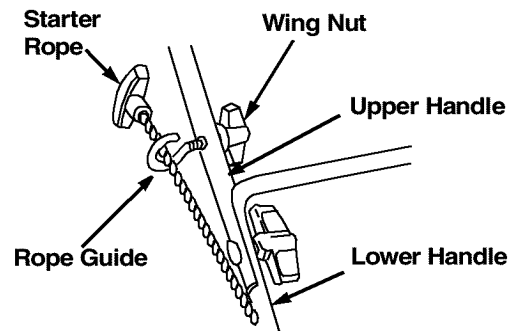

Figure 7

**NOTE:** Leave rear mulching baffle in place if you want to use your mower as a mulcher.

## Attaching Grasscatcher

- Remove the mulching baffle in order to install and use the grass catcher.
- Lift the rear discharge door and remove the rear mulching baffle from the mower. See Figure 8 .

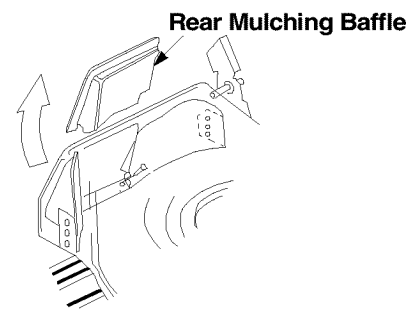

Figure 8

**NOTE:** Make sure that the cables are routed to the outside of the handle and out of the way when attaching the grasscatcher.

- Holding open the rear discharge door, place the grasscatcher on the pivot rod. Let go of the discharge door so that it rests on the grass catcher. See Figure 9 .
- To remove the grasscatcher:** Lift the rear discharge door and lift the grasscatcher up. Reinstall the rear mulching baffle and release the rear discharge door.

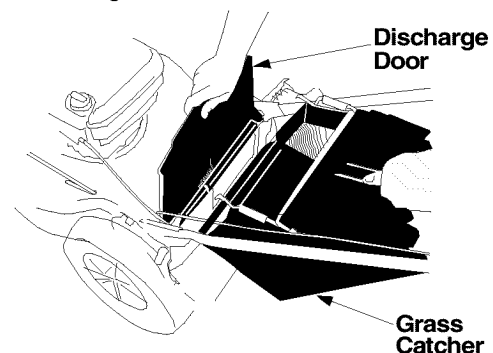

Figure 9



## SECTION 4: KNOW YOUR LAWN MOWER

Read this owner's manual and safety rules before operating your lawn mower. Compare the illustrations in Figure 10 with your lawn mower to familiarize yourself with the location of various controls and adjustments. Save this manual for future reference.



**WARNING:** The operation of any lawn mower can result in foreign objects being thrown into the operator's eyes thus causing severe eye damage. **Always wear safety glasses** while operating the mower, or while performing any adjustments or repairs on it.

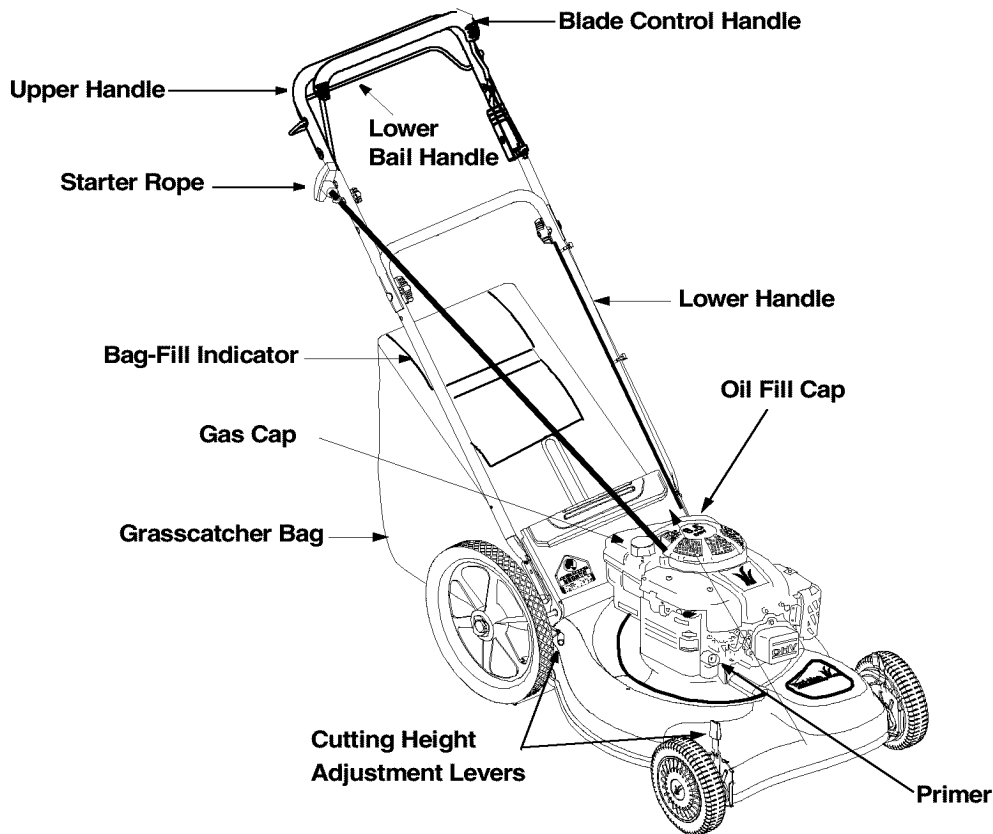

Figure 10

### Starter Rope

The starter rope is attached to the handle. Stand behind the unit and pull the starter rope to start the unit.

### Primer

The primer is used to pump gas into the carburetor. Use it to assist in starting a cold engine, but do not use it when restarting a warm engine after a short shutdown. Refer to Figure 10 .

### Blade Control Handle

The blade control handle is located on the upper handle of the mower. The blade control handle must be depressed in order to operate the unit. Release the blade control handle to stop the engine and the blade.



**WARNING:** The blade control handle is a safety device. Never attempt to bypass its operations or alter it in any way.

### Lower Bail Handle

The lower bail handle is located on the upper handle and is used to engage the drive. Squeeze the lower bail handle against the upper handle to engage the drive; release it to slow down or stop the mower from propelling.

### Grasscatcher Bag

The grass bag is equipped with a bag-fill indicator to add convenience to your work. While the mower is running, air will flow through the bag and into the "sail." If the grass catcher is **empty**, air flows through easily pushing the sail up. If the grass catcher is **full**, air does not flow through it allowing the sail to fall. So the position of the sail acts as a bag-fill indicator signifying when to empty the grass bag.

---

## SECTION 5: OPERATING YOUR LAWN MOWER



**WARNING:** Read, understand, and follow all instructions and warnings on the machine and in this manual before operating.

### Gas & Oil Fill-Up

- Check oil level and add oil if necessary. Follow relevant instructions in the engine manual for this.
- Service the engine with gasoline as instructed in the engine manual.



**WARNING:** Use extreme care when handling gasoline. Gasoline is extremely flammable and the vapors are explosive. Never fuel the machine indoors or while the engine is hot or running. Extinguish cigarettes, cigars, pipes and other sources of ignition.

### Before Starting Mower

- Attach spark plug wire to spark plug. Make certain the metal cap on the end of the spark plug wire (inside the rubber boot) is fastened securely over the metal tip on the spark plug.

### Throttle Speed

Your lawn mower engine is equipped with a constant speed throttle, which is set at full throttle for best performance.

### Starting Engine



**WARNING:** Be sure no one other than the operator is standing near the lawn mower while starting engine or operating mower.

**WARNING:** Never run engine indoors or in enclosed, poorly ventilated areas. Engine exhaust contains carbon monoxide, an odorless and deadly gas.

**WARNING:** Keep hands, feet, hair and loose clothing away from any moving parts on engine and lawn mower.

- Push primer three times. Wait about two seconds between each push. In cold weather around 55° F or below, prime five times. Do not prime to restart a warm engine after a short shutdown.
- Standing behind the mower, depress the blade control handle and hold it against the upper handle.
- Grasp starter handle and pull rope out slowly until engine reaches the start of compression cycle (rope will pull slightly harder at this point). Let the rope rewind slowly. Pull rope with a rapid,

continuous, full arm stroke. Keeping a firm grip on the starter handle, let the rope rewind slowly.

### Stopping Engine

- Release lower bail handle.
- Release blade control handle to stop the engine and the blade.
- Disconnect spark plug wire and move away from spark plug to prevent accidental starting.

### Using Your Lawn Mower



**WARNING:** Never operate the mower unless the hooks on the grasscatcher are seated in the slots on the handle bracket assemblies, and the rear discharge door rests firmly against the top of the grasscatcher.

- You can use your mower as a mulching mower or a rear bagger.
- **Do not** operate the mower without the rear mulching baffle or the grasscatcher bag properly installed.
- Be sure that the lawn is clear of stones, sticks, wire, or other objects which could damage lawn mower or engine. Such objects could be accidentally thrown by the mower in any direction and cause serious personal injury to the operator and others.
- *For best results, do not cut wet grass* because it tends to stick to the underside of the mower, preventing proper discharge of grass clippings, and could cause you to slip and fall. New grass, thick grass or wet grass may require a narrower cut.
- For a *healthy lawn*, always cut off one-third or less of the total length of the grass. Lawn should be trimmed in fall as long as there is growth.



**WARNING:** If the mower strikes a foreign object, stop the engine. Remove spark plug wire from the spark plug and thoroughly inspect for any damage. Repair the damage promptly before restarting and operating the mower.

### Adjusting Cutting Height

Refer to height adjustments section of this manual on page 14 for instruction on how to adjust the cutting height and the handle height.

For best results in mowing, keep the cutting height position high until you can determine a suitable height.

### Bagging Grass Clippings

You can use the grass catcher bag to collect clippings while you are operating the mower.

- Attach grass catcher following instructions on page 8 of this manual. Grass clippings will automatically collect in the bag as you run the mower.
- Operate the mower till the grass bag is full. Refer to page 9 for description of flow indicator.
- Stop engine completely by releasing the blade control handle. Make sure that the unit has come to a complete stop.

- Lift discharge door and pull grass bag up and away from the mower to dispose of the grass clippings.

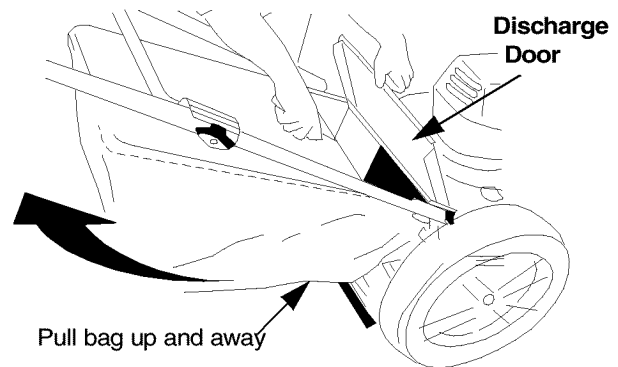

Figure 11

## SECTION 6: MAINTAINING YOUR LAWN MOWER



**WARNING:** Always stop the engine and disconnect the spark plug wire before performing any maintenance work or adjustments on your lawn mower.

### Cleaning Mower

The underside of the mower deck should be cleaned after each use to prevent any build-up of grass clippings, leaves, dirt, or other debris. If this debris is allowed to accumulate, it will result in rust and corrosion.

**NOTE:** We do not recommend the use of pressure washers or garden hose to clean your unit. These may cause damage to electric components, spindles, pulleys, bearings, or the engine. The use of water will result in shortened life and reduce serviceability.

- Disconnect spark plug wire.
- Drain the gasoline from the lawn mower, or place a piece of plastic under the gas cap.
- Tip the mower so that it rests on the housing. Keep the side with the air cleaner facing UP. Hold the mower firmly.
- Scrape and clean the underside of the deck with a suitable tool. Do NOT spray with water.
- Put the mower back on its wheels on the ground. If you had put plastic under the gas cap, make sure to remove it now.



**WARNING:** Never tip the mower more than 90 degrees in any directions and do not leave the mower tipped for any length of time. Oil can drain into the upper part of the engine causing a starting problem.

### Engine Care

A list of key maintenance jobs required for good performance by the mower is given below. Follow the accompanying engine manual for detailed list and instructions.

- Change engine oil regularly, as instructed in the engine manual. Check oil level before starting engine every time.
- Service foam filter in the air cleaner every 25 hours of use and replace the paper filter component every 100 hours. You may have to service the air filter more frequently if you are operating the mower under extremely dusty conditions.
- Clean the engine periodically. Remove dirt and debris with a cloth or brush.
- Clean the spark plug and reset the gap to .030" at least once a season. Refer to the engine manual for correct spark plug type.
- Inspect muffler periodically, and replace if necessary. Damaged mufflers or spark arresters can create a fire hazard. Make sure to avoid muffler and surrounding areas while the mower engine is hot because temperature of these areas of the engine may exceed 150° F.

### Lubrication

#### Wheels

- Lubricate the wheels and bearings, if so equipped, at least once a season with light oil or engine oil. Also, if the wheels are removed for any reason, lubricate the surface of the axle bolt and the inner surface of the wheel with light oil.

### Chute Deflector & Rear Discharge Door

- Lubricate the torsion spring and the pivot point on each end of the rear discharge door using a light oil. This will prevent rusting of the discharge door.

### Engine

- Follow the engine manual instructions and recommended schedule for lubricating engine components.

### Transmission

- The transmission is pre-lubricated and sealed at the factory and does not require lubrication on a regular basis as part of maintenance.

---

## SECTION 7: SERVICING YOUR LAWN MOWER

### Blade Care

Periodically inspect the blade adapter and pulley for cracks, especially if you strike a foreign object. Replace when necessary.



**WARNING:** When removing the cutting blade for sharpening or replacement, protect hands by using heavy gloves or a thick rag to grasp the cutting blade.

- Disconnect spark plug wire from spark plug.
- Turn mower on its side making sure that the air filter and the carburetor are up.

#### To Remove Blade:

- Remove the bolt and bell washer which hold the blade-pulley assembly to the engine crankshaft. See Figure 12 .

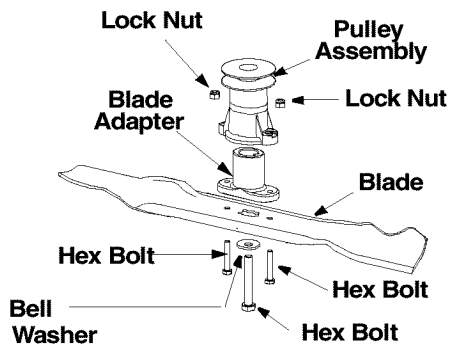

Figure 12

- Remove the blade-pulley assembly from the crankshaft.
- Remove the two bolts and lock nuts from the blade assembly. See Figure 12 .
- Remove the blade from the blade adapter and pulley.

#### To Replace Blade:

- Before reinstalling the blade-pulley assembly to the unit, lubricate the engine crankshaft and the inner surface of the blade adapter with light oil or engine oil.

- Also lubricate the bolt holes, bolt and the inner surface of the nuts.
- Install the blade adapter on the pulley with the “star” away from the pulley. See Figure 12 .
- Place the new blade on the blade adapter with the side marked bottom (or with part number) facing away from the adapter.
- Secure the blade to the assembly with two hex bolts and lock nuts. Tighten the hex bolts to the recommended torque. Refer to ‘Blade Mounting Torque’ section on next page.
- Install the blade assembly on the crankshaft. Secure with the hex bolt and bell washer (cupped side of washer to blade) and tighten to the recommended torque. Refer to ‘Blade Mounting Torque’ section on next page.

**IMPORTANT:** The bolt used to secure the blade to the engine is specially heat-treated. **Do not substitute.** To order replacement bolt, refer to the parts list in the back of this manual.



**WARNING:** To ensure safe operation of your unit, all nuts and bolts must be checked periodically for correct tightness.

#### To Sharpen Blade:

- The blade can be sharpened with a file or on a grinding wheel. Do not attempt to sharpen the blade while it is still on the mower.
- Follow the original angle of grind as a guide. Make sure that each cutting edge receives an equal amount of grinding to prevent an unbalanced blade.

**NOTE:** An unbalanced blade will cause excessive vibration when rotating at high speeds, may cause damage to the mower and could break, causing personal injury. Test the blade by balancing it on a round shaft screwdriver or a blade balancer.

- If the blade is not balanced, remove metal from the heavy side until it balances evenly.

### Blade Mounting Torque:

Blade adapter bolts: 120 in.lbs. minimum, 150 in.lbs. maximum  
Center bolt: 450 in.lbs. minimum, 600 in.lbs. maximum.

## Replacing Drive Belt

- Remove two shoulder screws securing the front drive cover to the mower deck. See Figure 13 .
- Press inward on the sides of the front drive cover and release the tabs that secure the front drive cover to the height adjuster brackets. Remove drive cover from the mower.
- Using a torx wrench, loosen the screw holding the belt tension spring to the transmission. See Figure 13 . Do not remove the screw completely. As you loosen the screw, the tension on the belt will be released.
- Push the transmission up a little and slide the belt off the transmission pulley.
- Lift the mower to access the belt from the underside of the mower.

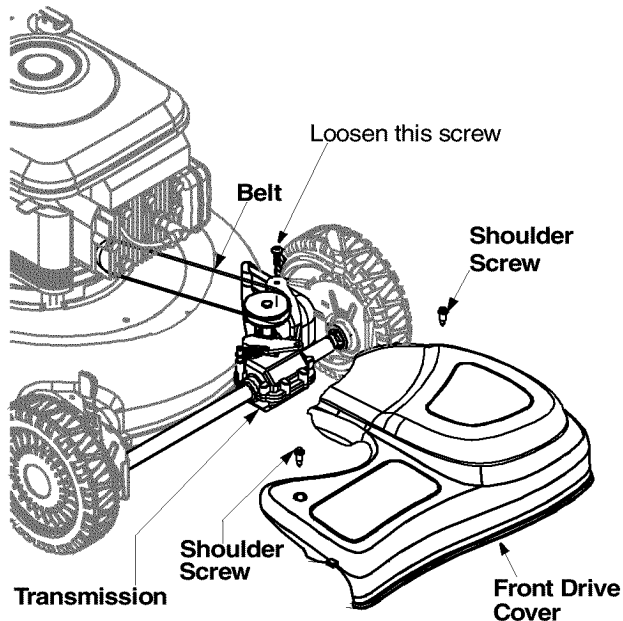

Figure 13

- Slide the belt off the engine pulley and around the blade. See Figure 14 .

**WARNING:** As always, use a thick piece of rag to handle the blade while sliding the belt around it. Make sure the engine does not start at all while doing this job.

- Replace with the new belt, working around the blade. Make sure the belt is firmly seated on the engine pulley while pulling from the other side and sliding it around the transmission pulley.
- Put the mower down with all four wheels firmly placed on one level.

- Tighten the screw, loosened earlier, to secure the belt tension spring to the transmission, and reassemble the front drive cover.

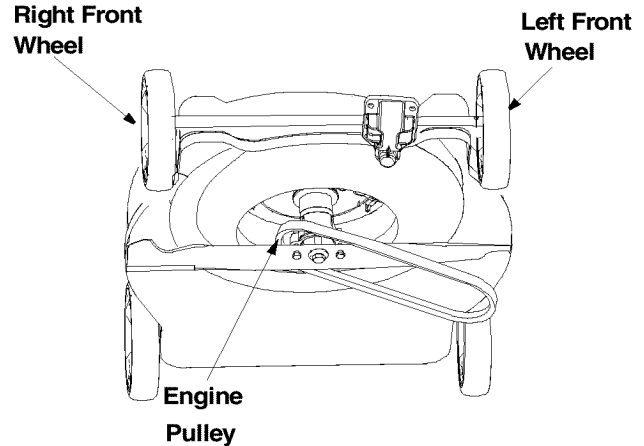

Figure 14

## Replacing Rear Flap

- To remove rear flap, cut off the flat end of the wire rod which secures it to the deck. See Figure 15 .
- Attach the new flap and new rod to deck, bending the ends of the new rod over to secure to deck.

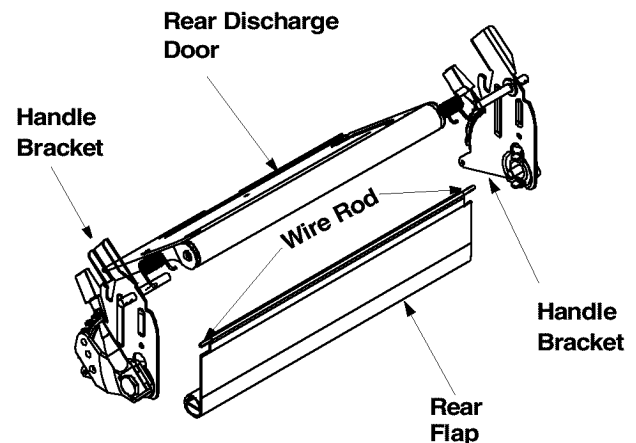

Figure 15

## Adjusting Handle Height

Your mower is shipped with the handle in the higher height position.

- Remove the starter rope from the rope guide.
- Remove the upper handle by removing the hand knobs and carriage bolts. Lay the upper handle out of the way, being careful not to bend or kink cables.
- Remove the hairpin clips from the weld pins on the handle brackets. Refer to Figure 5 .
- Remove the carriage bolts and wing nuts from the handle brackets. Press out on the legs of the lower handle. Remove lower handle from the mower.

- Turn the lower handle around so the notch on the bottom of the lower handle is facing forward as shown in Figure 16 . Reassemble, placing the bottom holes in the handle over the weld pins in the handle mounting bracket.

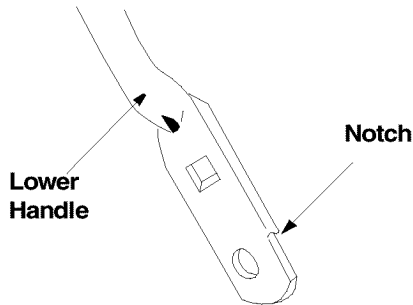

Figure 16

- Reassemble the upper handle to the lower handle.
- Place the hairpin clips in the inner holes of the weld pins and replace the carriage bolts and wing nuts on the handle brackets. Attach the starter rope as instructed in the Assembly section.

## Adjusting Cutting Height

**IMPORTANT:** All wheels must be placed in the same relative position. For rough or uneven lawns, move the height adjustment lever to a higher position. This will help stop scalping of the grass.

An adjusting plate and thumb lever at each wheel position provides cutting height adjustment. Each adjusting plate has nine height positions. Height of cut will be changed when you move the thumb lever from one position to another.

- Simply depress the lever towards the wheel and move the lever assembly to desired position. See Figure 17 .
- For rough or uneven lawns, move the height adjustment handles to higher cutting height position.

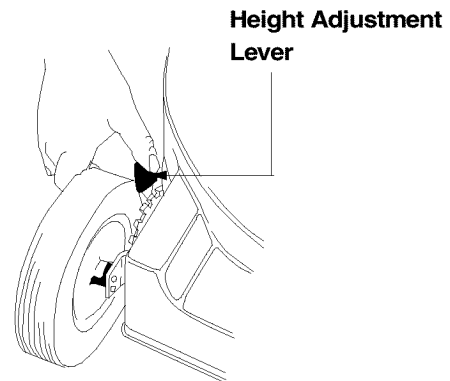

Figure 17

## Adjusting Carburetor

If the engine is running rough, minor adjustments to the carburetor may be required to compensate for differences in fuel, temperature, altitude and load.

**NOTE:** *Dirty air cleaner may cause an engine to run rough. Before adjusting carburetor, check air cleaner.*

To adjust the carburetor, please follow the recommendations and instructions on carburetor adjustment in the engine manual.

**WARNING:** If any adjustments are made to the engine (e.g. carburetor) while the engine is running, keep clear of all moving parts. Be careful of heated surfaces like the muffler.

---

## SECTION 8: OFF-SEASON STORAGE

Prepare your lawn mower for storage at the end of the season or **if the unit will not be used for 30 days** or more. Store the mower in a **clean, dry area**.

### Mower

- Clean underside of the mower following instructions in the Maintain Your Lawn Mower section of this manual.
- Lubricate mower as instructed on page 12 of this manual.
- You can fold your mower's handle for convenient storage: Remove the starter rope from the rope

guide; loosen the two hand knobs on the sides of the handle, and let the upper handle fold down to the rear. Move the hairpin clips to the outer hole in the weld pins on the handle mounting brackets. Spread the sides of the lower handle, and push it forward and down.

- Inspect and replace/sharpen blade, if required.

### Engine

- Follow recommendations in the accompanying engine manual for off-season storage of the engine.

- Change oil if it has not been changed in the last three months. For instructions on how to change oil, refer to the engine manual.
- Clean engine and remove any grass clippings.

- Replace your gasoline can if it starts to rust. Rust and/or dirt in the gasoline will cause problems. Store unit in a clean, dry area. Do not store next to corrosive materials, such as fertilizer.

## Other

- Do not store gasoline from one season to another.

**NOTE:** *If storing in an unventilated or metal storage shed, be certain to rustproof the equipment by coating with a light oil or silicone.*

---

## SECTION 9: TROUBLE-SHOOTING

Problem	Possible Cause	Corrective Action
Engine fails to start	<ol style="list-style-type: none"> <li>1. Blade control handle disengaged</li> <li>2. Spark plug wire disconnected</li> <li>3. Fuel tank empty, or stale fuel</li> <li>4. Blocked fuel line</li> <li>5. Faulty spark plug</li> <li>6. Engine flooded</li> </ol>	<ol style="list-style-type: none"> <li>1. Engage blade control handle</li> <li>2. Connect wire to spark plug</li> <li>3. Fill up tank with fresh gasoline</li> <li>4. Clean fuel line</li> <li>5. Clean, adjust gap, or replace</li> <li>6. Wait a few minutes to restart, Do not prime.</li> </ol>
Engine runs erratic	<ol style="list-style-type: none"> <li>1. Spark plug wire loose</li> <li>2. Blocked fuel line or stale fuel</li> <li>3. Vent in gas cap plugged</li> <li>4. Water or dirt in fuel system</li> <li>5. Dirty air cleaner</li> </ol>	<ol style="list-style-type: none"> <li>1. Connect and tighten spark plug wire.</li> <li>2. Clean fuel line, fill tank with fresh gasoline.</li> <li>3. Clear vent.</li> <li>4. Drain fuel tank. Refill with fresh fuel.</li> <li>5. Clean air cleaner. Refer to engine manual.</li> </ol>
Engine overheats	<ol style="list-style-type: none"> <li>1. Engine oil level low</li> <li>2. Air flow restricted</li> </ol>	<ol style="list-style-type: none"> <li>1. Fill crankcase with proper oil.</li> <li>2. Clean lawn mower engine.</li> </ol>
Occasional skip (hesitates) at high speed	<ol style="list-style-type: none"> <li>1. Spark plug gap too close</li> </ol>	<ol style="list-style-type: none"> <li>1. Adjust gap to .030 inches.</li> </ol>
Idles poorly	<ol style="list-style-type: none"> <li>1. Spark plug faulty, or gap too wide</li> <li>2. Dirty air cleaner</li> </ol>	<ol style="list-style-type: none"> <li>1. Reset gap to .030 inches or replace spark plug.</li> <li>2. Clean air cleaner.</li> </ol>
Excessive vibration	<ol style="list-style-type: none"> <li>1. Blade loose or unbalanced</li> <li>2. Bent cutting blade</li> <li>3. Bent engine crankshaft</li> </ol>	<ol style="list-style-type: none"> <li>1. Tighten blade and adapter, balance blade.</li> <li>2. Replace blade.</li> <li>3. Contact the nearest service center</li> </ol>
Mower will not mulch grass	<ol style="list-style-type: none"> <li>1. Wet grass</li> <li>2. Excessively high grass</li> <li>3.</li> <li>4. Dull blade</li> </ol>	<ol style="list-style-type: none"> <li>1. Wait until grass is dry to cut.</li> <li>2. Mow once at a high cutting height, then mow again at desired height.</li> <li>3. Sharpen or replace blade.</li> </ol>
Uneven cut	<ol style="list-style-type: none"> <li>1. Wheels not at same height</li> <li>2. Dull blade</li> </ol>	<ol style="list-style-type: none"> <li>1. Reposition all wheels at same height.</li> <li>2. Sharpen or replace blade.</li> </ol>

**NOTE:** *For repairs beyond the minor adjustments listed above, contact your local authorized service dealer.*

# SECTION 10: PARTS LIST FOR MODEL 559

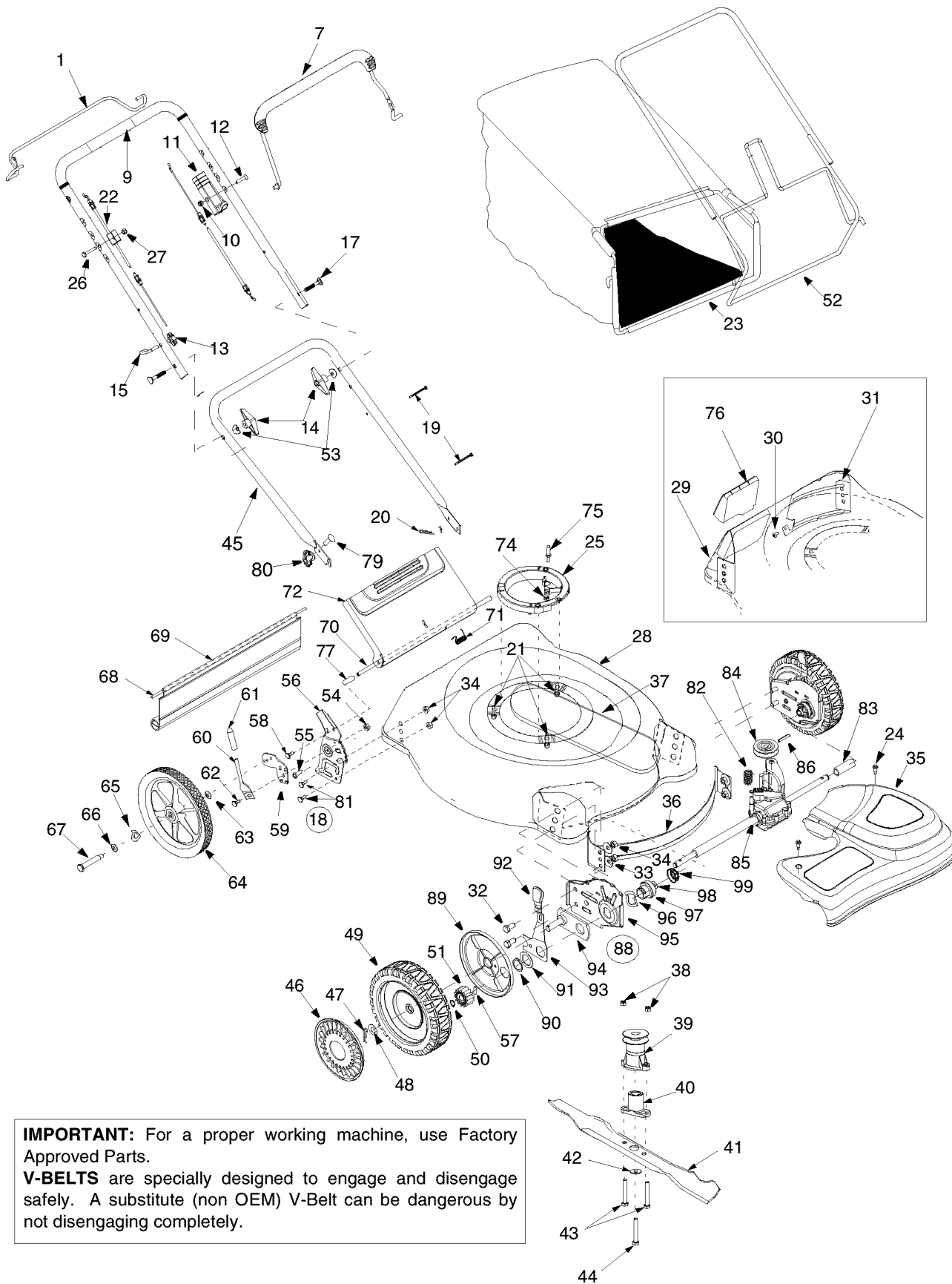



# Model 559

Ref. No	Part No.	Description	Ref. No	Part No.	Description
1.	747-2136	Lower Bail Handle	48.	736-3013	Flat Washer
6.	746-0960	Drive Cable	49.	734-2042	Wheel 8 x 2
7.	747-0824	Control Lever	50.	716-0865	Snap Ring
8.	749-1499	Upper Handle	51.	717-1761	Gear 14T LH FWD
9.	720-0294	Foam Grip, 9"		717-1762	Gear 14T RH FWD *
10.	712-0324	Hex Lock Nut, 1/4-20	52.	747-0995A	Grass Bag Frame RR
11.	746-0883	Throttle Housing	53.	736-0451	Saddle Washer
12.	710-1270	Oval C-Sunk Screw 1/4-20 x 1.31	54.	712-3005	Hex Flange Lock Nut 3/8-16
13.	720-0279	Handle Knob	55.	710-0896	Hex Scr. w/Washer 1/4-14 x .625
14.	720-0284	Handle Knob	56.	682-3056A	RH Handle Bracket
15.	710-1205	Eye Bolt		682-3057A	LH Handle Bracket *
16.	746-0554	Control Cable, 40.5"	57.	715-0221	Dowel Pin
17.	710-1174	Carriage Bolt 5/16-18 x 2.0	58.	710-0286	Pan Head Screw
18.	682-3058	RH Bracket Ass'y	59.	17488A	RH Pivot Bar
	682-3059	LH Bracket Ass'y *		17489A	LH Pivot Bar (not shown)
19.	726-0240	Cable Tie	60.	732-0866	Height Adj. Lever
20.	714-0104	Cotter Pin	61.	720-0312	Foam Grip
21.	710-1007	Self-Tapping Screw	62.	738-0507B	Shoulder Scr .500 Dia. x .434
22.	746-1146	Drive Cable	63.	736-0105	Washer .401 x .870 x .063
23.	664-0123	Grassbag Assembly (Half Sail)	64.	734-2043	Wheel, 14 x 2
24.	710-1650	Shoulder Screw # 12 -24	65.	736-0182	Spring Washer .50 I.D. x 1.0 O.D.
25.	631-0075B	Engine Spacer	66.	736-0456	Flat Washer .510 x 1.373 x .04
26.	710-0606	Hex Bolt 1/4-20 x 1.5	67.	738-0481A	Shoulder Screw
27.	712-0324	Lock Nut 1/4-20	68.	732-0700	Wire
28.	782-0080A	21" Rear Discharge Deck	69.	731-1236	Rear Trailing Shield
29.	782-5004	RH Rear Baffle	70.	747-0996	Pivot Rod
30.	710-1017	Screw AB: 1/4-14: .625	71.	732-0809	Torsion Spring
31.	782-5003	LH Rear Baffle	72.	782-7599A	Rear Discharge Door
32.	710-0216	Hex Screw 3/8-16 x .75	74.	712-0271	Hex Nut
33.	736-0331	Bell Washer .39 x 1.13 x .062	75.	711-1293	Screw
34.	712-0431	Hex Nut 3/8-16	76.	782-5007A	Plastic Mulching Plug
35.	731-2600	Transmission Cover (Yellow)	77.	750-0434	Spacer .375 x .50 x 1.02" Lg.
36.	782-5002	Front Baffle	78.	738-1002	Shoulder Screw 1/4-14
37.	754-0637	V-Belt	79.	710-0703	Carriage Bolt 1/4-20
38.	712-0324	Hex Nut 1/4-20	80.	712-0397	Wing Nut
39.	756-1146A	Drive Pulley	81.	710-0216	Hex Bolt 3/8-16 x 1.0"
40.	748-0411	Blade Adapter	82.	732-1043	Belt Tension Spring
41.	742-0741	21" Mulching Blade	83.	750-1165	Slev. Spacer RH
42.	736-0452	Flat Washer .516 x 1.5 x .134		750-1166	Slev. Spacer LH*
43.	710-0606	Hex Screw 1/4-20 x 1.50	84.	756-1231	Input Pulley
44.	710-1257	Hex Screw 3/8-24 x 2.50	85.	618-0657	Transmission Assembly
45.	749-0907B	Lower Handle	86.	715-0169	Roll Pin
46.	731-1426	Hub Cap	88.	682-0512A	Height Adjustment Assembly RH
47.	714-0101	Cotter Pin		682-0511A	Height Adjustment Assembly LH*

\* Not shown in illustration

Table continued on next page

# Model 559

Table continued from previous page

Ref. No	Part No.	Description
89.	782-7551	Wheel Dust Cap
90.	716-0102	Snap Ring
91.	736-0474	Washer
92.	720-0426	Adjustment Knob
93.	732-0706	Front Lever RH
	732-0707	Front Lever LH*
94.	682-0509	Pivot Plate Assembly
95.	782-0512B	Height Adj. Plate RH
	782-0511A	Height adj. Plate LH*
96.	736-0447	Wave Washer
97.	748-0355	Bearing Support
98.	741-0604A	Bearing Sleeve
99.	732-0708	Bearing Retainer

\* Not shown in illustration

**NOTE:** For **painted parts**, please refer to the list of color codes below. Please add the applicable color code, wherever needed, to the part number to order a replacement part. For instance, if a part numbered 700-xxxx is painted Yard-Man Green, the part number to order would be 700-xxxx-0665.

Yard-Man Green: 0665

Yard-Man Yellow: 0674

Powder Black: 0637

# Safety & Decorative Labels

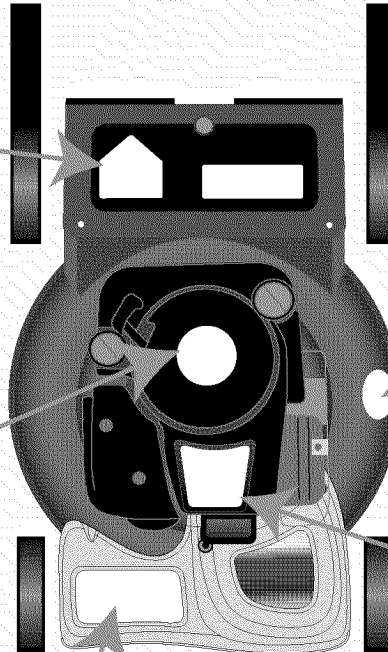

777D00535  
ON FRONT WHEEL  
COVERS



# MANUFACTURER'S LIMITED WARRANTY FOR:



The limited warranty set forth below is given by MTD LLC with respect to new merchandise purchased and used in the United States, its possessions and territories.

MTD LLC warrants this product against defects for a period of two (2) years commencing on the date of original purchase and will, at its option, repair or replace, free of charge, any part found to be defective in materials or workmanship. This limited warranty shall only apply if this product has been operated and maintained in accordance with the Operator's Manual furnished with the product, and has not been subject to misuse, abuse, commercial use, neglect, accident, improper maintenance, alteration, vandalism, theft, fire, water, or damage because of other peril or natural disaster. Damage resulting from the installation or use of any accessory or attachment not approved by MTD LLC for use with the product(s) covered by this manual will void your warranty as to any resulting damage.

Normal wear parts or components thereof are subject to separate terms as follows: All normal wear parts or component failures will be covered on the product for a period of 90 days regardless of cause. After 90 days, but within the two year period, normal wear part failures will be covered ONLY IF caused by defects in materials or workmanship of OTHER component parts. Normal wear parts and components include, but are not limited to: batteries, belts, blades, blade adapters, grass bags, rider deck wheels, seats, snow thrower skid shoes, shave plates, auger spiral rubber, and tires.

**HOW TO OBTAIN SERVICE:** Warranty service is available, WITH PROOF OF PURCHASE, through your local authorized service dealer. To locate the dealer in your area, check your Yellow Pages, or contact MTD LLC at P.O. Box 361131, Cleveland, Ohio 44136-0019, or call 1-800-800-7310 or log on to our Web site at [www.mtdproducts.com](http://www.mtdproducts.com).

This limited warranty does not provide coverage in the following cases:

- a. The engine or component parts thereof. These items carry a separate manufacturer's warranty. Refer to applicable manufacturer's warranty for terms and conditions.
- b. Log splitter pumps, valves, and cylinders have a separate one year warranty.
- c. Routine maintenance items such as lubricants, filters, blade sharpening, tune-ups, brake adjustments, clutch adjustments, deck adjustments, and normal deterioration of the exterior finish due to use or exposure.

- d. MTD LLC does not extend any warranty for products sold or exported outside of the United States, its possessions and territories, except those sold through MTD LLC's authorized channels of export distribution.
- e. Parts that are not genuine MTD parts are not covered by this warranty.
- f. Service completed by someone other than an authorized service dealer is not covered by this warranty.
- g. Transportation charges and service calls are not covered.

**No implied warranty, including any implied warranty of merchantability of fitness for a particular purpose, applies after the applicable period of express written warranty above as to the parts as identified. No other express warranty, whether written or oral, except as mentioned above, given by any person or entity, including a dealer or retailer, with respect to any product, shall bind MTD LLC. During the period of the warranty, the exclusive remedy is repair or replacement of the product as set forth above.**

**The provisions as set forth in this warranty provide the sole and exclusive remedy arising from the sale. MTD LLC shall not be liable for incidental or consequential loss or damage including, without limitation, expenses incurred for substitute or replacement lawn care services or for rental expenses to temporarily replace a warranted product.**

Some states do not allow the exclusion or limitation of incidental or consequential damages, or limitations on how long an implied warranty lasts, so the above exclusions or limitations may not apply to you.

In no event shall recovery of any kind be greater than the amount of the purchase price of the product sold. **Alteration of safety features of the product shall void this warranty.** You assume the risk and liability for loss, damage, or injury to you and your property and/or to others and their property arising out of the misuse or inability to use the product.

This limited warranty shall not extend to anyone other than the original purchaser or to the person for whom it was purchased as a gift.

**HOW STATE LAW RELATES TO THIS WARRANTY:** This limited warranty gives you specific legal rights, and you may also have other rights which vary from state to state.

**MTD LLC, P.O. BOX 361131 CLEVELAND, OHIO 44136-0019; Phone: 1-800-800-7310**