

Friedrich®

Vert-I-Pak®

Single Package Vertical Air Conditioning System

A-Series

24,000 BTU/h

Installation & Operation Manual

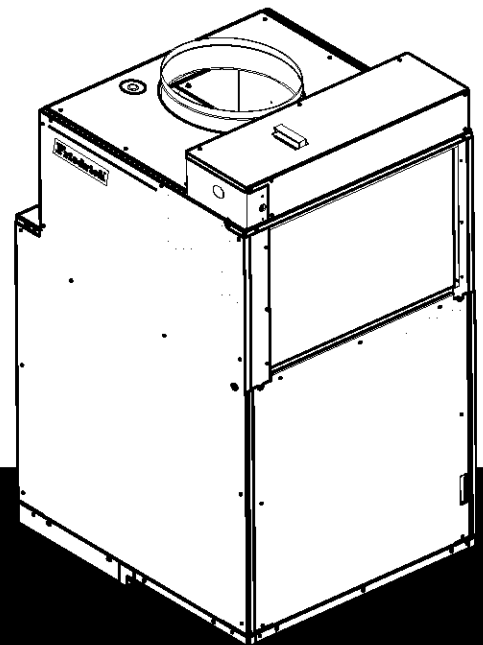

Table of Contents

Installation Recommendations	3
I. General Specifications	
Model Number Identification Guide	4
VERT-I-PAK Chassis Specifications	4
II. Installation	
1. Utility Closet Dimensions	5
2. Wall Plenum & Architectural Louver Installation	6
3. Electrical Information	7-9
4. Indoor Return Air Grille Installation	10
5. Ductwork Preparation and CFM	11
6. Chassis Installation.....	11
7. Chassis Final Connections (Electrical, Duct, Drain & Wall Thermostat).....	12
8. Final Installation Checklist.....	12
III. Chassis Operation	
9. Thermostat Control	12
10. Low Ambient Protection for Compressor & Fan	12
11. Heating Defrost (Heat Pump Models only).....	12
12. Fresh Air Door.....	13
13. Condensate Disposal System	13
IV. Service, Maintenance & Warranty	
14. Servicing / Chassis Quick Changeouts.....	13
15. Routine Maintenance	13
16. Warranty	14
V. Vert-I-Pak Accessories	15

Please read this manual thoroughly prior to equipment installation or operation. It is the installer's responsibility to properly apply and install the equipment. Installation must be in conformance with the NFPA 70-2002 National Electric Code or current edition and Universal Mechanical Code current edition and applicable local or national codes.

Proper installation is not difficult but it is essential.

Vert-I-Pak Installation Recommendations

For proper unit performance and maximum operating life please refer to the minimum installation clearances below.

Figure 1

VERT-I-PAK® units must be installed on an outside wall. Confined spaces and/or covered areas should be avoided. Units should be installed no closer than 12" apart when two units are side by side. If three or more units are to operate next to one another allow a minimum of 60" between units or pairs of units. Also, a vertical clearance of 60" should be maintained between units. Units installed on the bottom floor should be mounted at least 6" off of the ground.

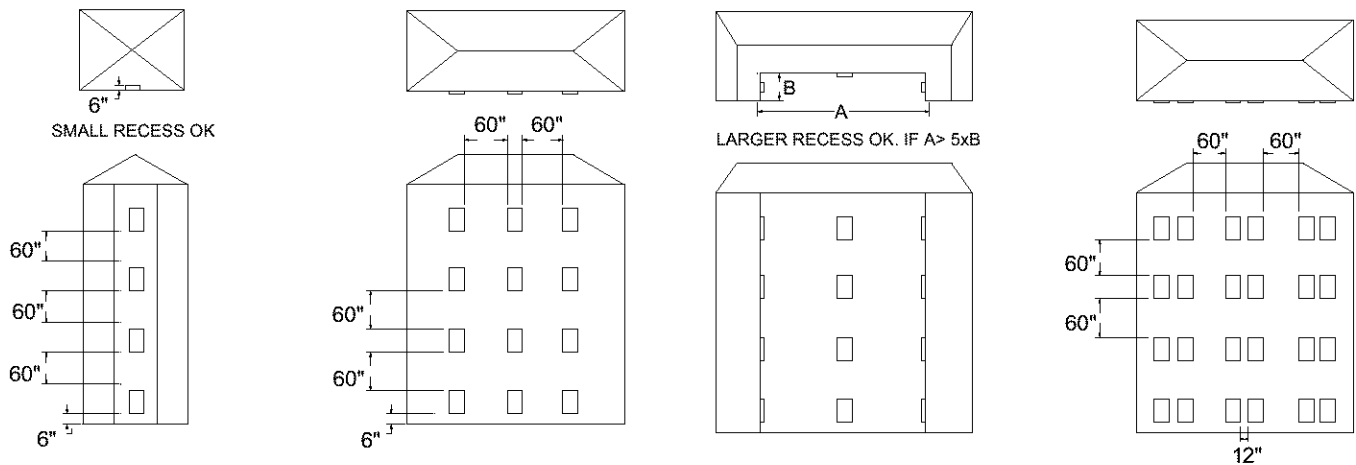
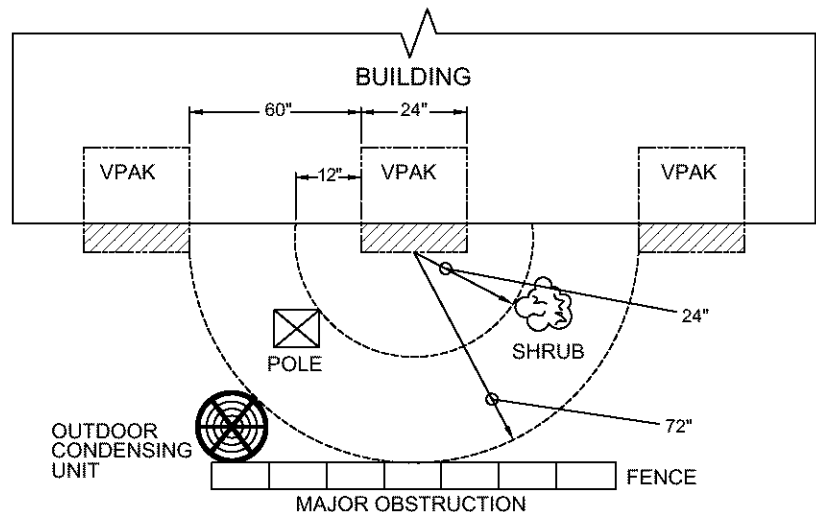

Figure 2

Any time obstructions are present use the following guidelines for proper spacing from the VERT-I-PAK louver:

- For minor obstructions such as lamp poles or small shrubbery a clearance of 24" from the outdoor louver should be maintained.
- For major obstructions such as a solid fence, wall or other heat rejecting device like a condensing unit, a minimum distance of 72" should be kept.



The above suggestions are for reference only and do not represent all possible installations. Please contact the factory for information regarding affects of other installation arrangements.

By following these simple recommendations you can be confident that your Friedrich Vert-I-Pak® will provide years of worry-free operation.

Section I. General Specifications

VERT-I-PAK® MODEL IDENTIFICATION GUIDE									
MODEL NUMBER	V	E	A	24	K	50	RT	A	
SERIES V=Vertical Series								ENGINEERING CODE	
E=Cooling with or without electric heat H=Heat Pump								OPTIONS RT = Standard Remote Operation SP = Seacoast Protected	
DESIGN SERIES A = 32" and 47" Cabinet								ELECTRIC HEATER SIZE A-Series 00 = No electric heat 25 = 2.5 KW 34 = 3.4 KW 50 = 5.0 KW 75 = 7.5 KW 10 = 10 KW	
NOMINAL CAPACITY A-Series (Btu/h) 09 = 9,000 12 = 12,000 18 = 18,000 24 = 24,000									
VOLTAGE K = 208/230V-1Ph-60Hz									

Vert-I-Pak® Chassis Specifications	
MODEL:	V(E,H)A24
Voltage (V)	230/208
Refrigerant	R-22
Chassis Width	23.125
Chassis Depth	23.125
Chassis Height **	47.25
Supply Duct Collar ***	10"
Drain Connection	3/4" FPT
Min. Circuit Amps	See Nameplate
CFM Indoor	See chart, pg. 11
Max. Duct ESP	.4 in. water

NOTES:

** Height includes 2" duct collar & isolators under unit.

*** Factory collar accepts 10" flex duct.

II. Installation

1) Utility Closet Dimensions

Recommended utility closet dimensions and a typical indoor installation are illustrated in Figure 1. Three inches minimum clearance on three sides of the unit must be allowed for return airflow, installation access and service access. See Figures 1 & 2 for clearances and reference dimensions.

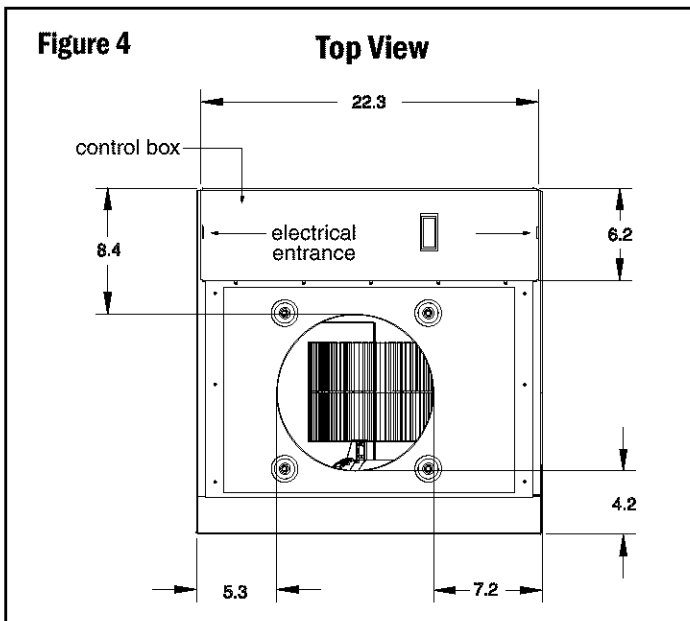
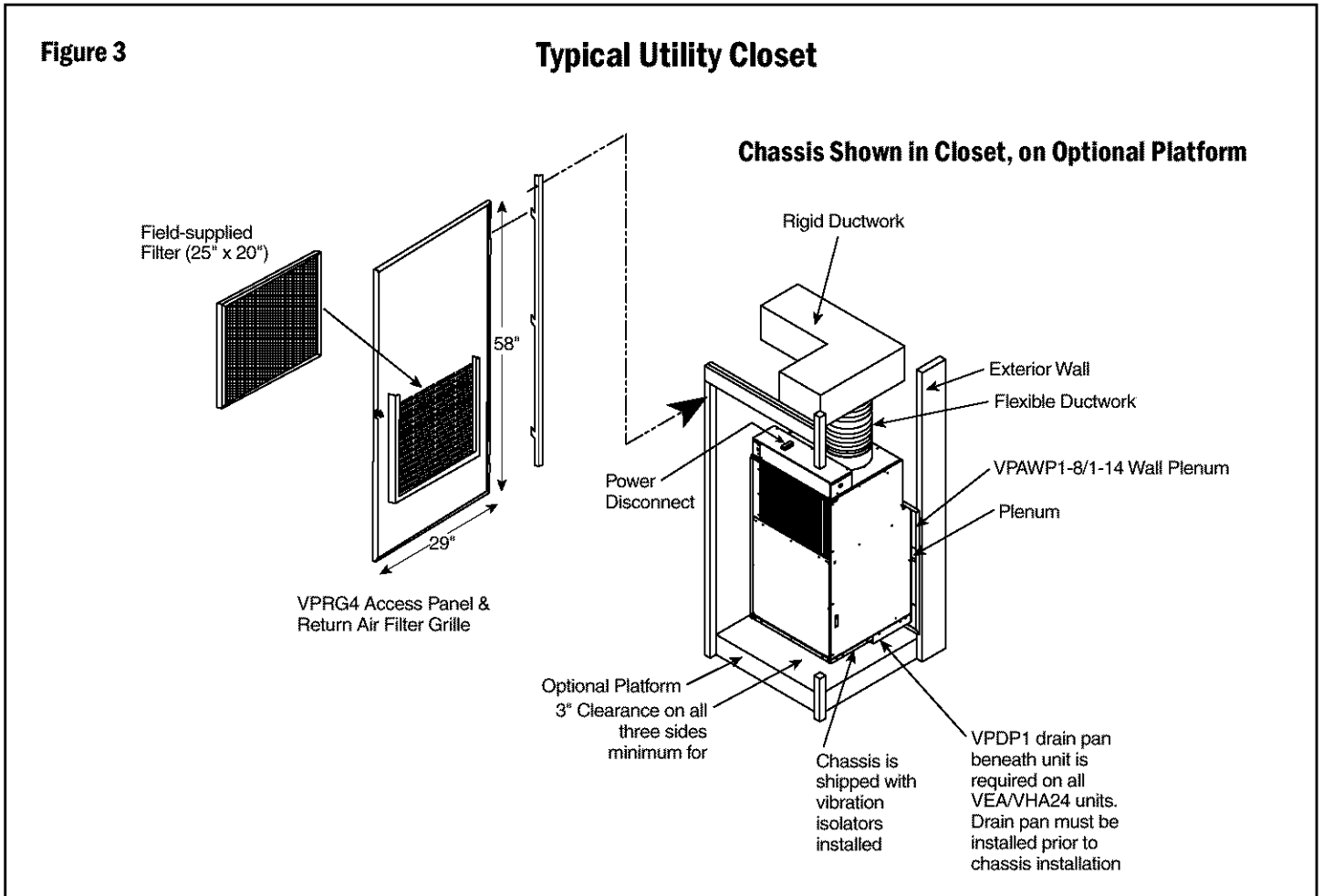

- Vert-I-Pak Chassis 2-ton dimensions: 23" wide x 23" deep x 47 1/4" high.
- VPAWP1-8/1-14 Wall Plenum cut-out dimensions 24 5/8" wide x 30 7/8" high.
- VPRG4 Access Panel cutout dimensions: 27" wide by 55 3/4" high.
- See Figure 8 (Page 10) for proper chassis installation.

NOTE: Drain pan must be installed in closet prior to chassis insertion into plenum. See Figure 7 (page 8) for drain pan installation details.

2) Wall Plenum and Architectural Louver Installation

A. Install the wall plenum (VPAWP1-8/1-14) components in accordance with the installation instructions provided with each accessory.



IMPORTANT REMINDER: FRIEDRICH WALL PLENUM IS NOT DESIGNED TO CARRY STRUCTURAL LOADS. PROPER WALL HEADER CONSTRUCTION IS REQUIRED. THE PLENUM REQUIRES PROPER FLASHING, SHIM AND CAULK FOR A WEATHER RESISTANT INSTALLATION.

B. Ensure that the divider is adjusted properly for the depth of the wall in accordance with the accessory installation manual

Figure 5

Wall Plenum & Outdoor Louver Installation

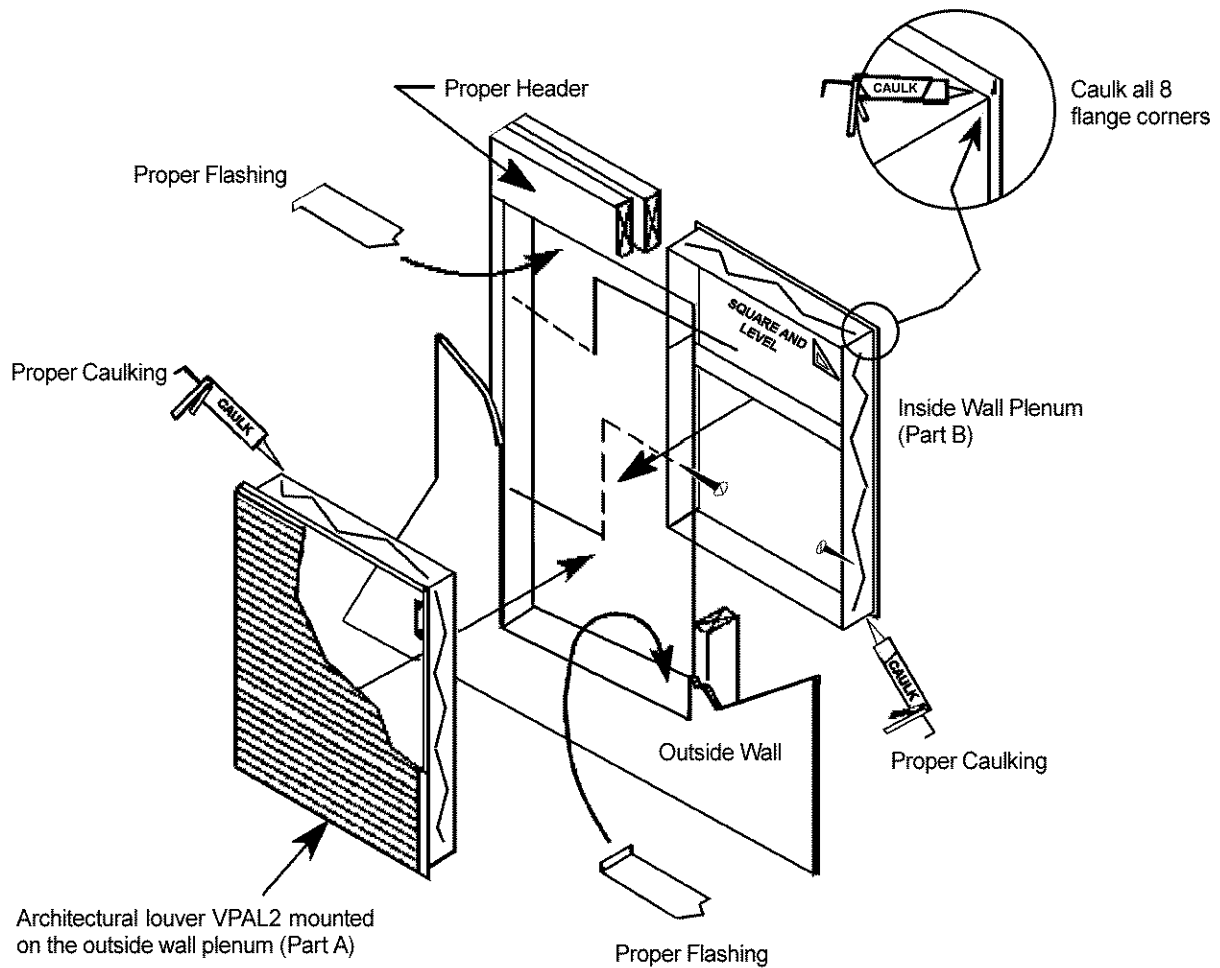

- Rough opening dimension 24 5/8" wide x 30 7/8" high.
- Ensure that the bottom of the plenum is 1 1/2" from the floor of the closet. Note: 9,000 / 12,000 / 18,000 installation height may be different. Refer to specific installation manual for clarification.
- For proper airflow, maintain a minimum distance of 12" between Vert-I-Pak units. Consult the factory for any installation or application questions.

3) Electrical Information

Electrical Data

	MODEL					
	VHA/VEA24K25	VHA/VEA24K34	VHA/VEA24K50	VHA/VEA24K75	VHA/VEA24K10	VHA/VEA24K00
Voltage (V)	230/208	230/208	230/208	230/208	230/208	230/208
LRA - Comp. (A)	68	68	68	68	68	68
Cooling Current (A)	13.7/12.4	13.7/12.4	13.7/12.4	13.7/12.4	13.7/12.4	13.7/12.4
MIN. Ckt. Amps (A)	17.2/15.9	22.1/20.3	30.7/28.1	44.3/40.3	57.9/52.7	15.6/15.6
Max Branch Circuit Fust (Amps)	25/25	25/25	35/30	45/45	60/60	20/20
Power Connection	HARD WIRED					
Recommended Branch Circuit Wire Sizes* AWG - American Wire Gauge	14/14	12/12	8/10	6/6	4/6	14/14

* Single circuit from main box. Based on copper wire, single insulated conductor at 60°C.

NOTE: Use copper conductors ONLY. Wire sizes are per NEC. Check local codes for overseas applications.

Sample Nameplate (see your chassis nameplate)

<p>MODEL NO SERIAL NO</p> <p>FRIEDRICH AIR CONDITIONING CO. SAN ANTONIO, TEXAS</p> <p>VOLTS: 24,33,34 VOLTAGE RANGE: 253-197 REFRIG CHARGE: 7 OZS. R22 DESIGN PRESSURE: 375 PSIG HS / 150 PSIG LS COOLING: BTU/HR 8 EER: 10 TOTAL COOLING AMPS: 9 TOTAL ELEC. HEAT AMPS: 15 ELECTRIC HEAT WATTS: 18</p> <p>FOR PERMANENTLY CONNECTED UNITS ONLY: COMP: RLA 11 LRA 12 FAN MOTOR: FLA13 HP 19 BLOWER MOTOR: FLA HP HEATER AMPS: 17 MIN. CKT AMP 20 USE 21 MAX. TIME FUSE OR HACR TYPE CIRCUIT BREAKER.</p> <p>GENERAL UNIT INFORMATION: MAX OUTLET AIR TEMPERATURE: 200°F MAX EXTERNAL STATIC PRESSURE ELECTRIC HEAT: .3 IN. WATER "0" CLEARANCE TO COMBUSTIBLE MATERIAL</p> <p>USE ON SINGLE OUTLET CIRCUIT ONLY</p>	<p style="text-align: center;">WARNING</p> <p style="text-align: center;">ELECTRICAL SHOCK AND MOVING PARTS HAZARD CAN CAUSE INJURY OR DEATH PULL OUT SCORNING HEAD CAUTION TO PROTECT AS USABLE POWER BEFORE SERVICING.</p> <p style="text-align: center;">↓</p>	<p>HEATING AND COOLING EQUIPMENT</p> <p>ONE OF THE FOLLOWING ITEMS FROM EACH CATEGORY TO COMPLETE THE ASSEMBLY</p> <p>WALL PLENUM: VPAWP1-8 VPAWP1-14 OUTDOOR GRILLE VPAL2 INDOOR GRILLE VPRG2 VPRG4</p>
---	---	--

! CAUTION!

IMPORTANT: ALL 208/230V CHASSIS MUST BE HARD WIRED WITH PROPERLY SIZED BREAKER. SEE NAMEPLATE FOR SPECIFIC CHASSIS ELECTRICAL REQUIREMENTS. SEE PAGE 9 - FIGURE 8 FOR UNIT WIRING AND WALL THERMOSTAT WIRING. SEE PAGE 7 FOR WIRE SIZE. USE HACR TYPE BREAKERS TO AVOID NUISANCE TRIPS. ALL FIELD WIRING MUST BE DONE IN ACCORDANCE WITH NEC AND LOCAL CODES.

3) Electrical Information (continued)**Figure 6****Electrical Requirements**

Note: All field wiring must comply with NEC and local codes. It is the responsibility of the installer to insure that the electrical codes are met.

Wire Size	Use ONLY wiring size recommended for single outlet branch circuit.
Fuse/Circuit Breaker	Use ONLY type and size fuse or HACR circuit breaker indicated on unit's rating plate (See sample on page 6). Proper current protection to the unit is the responsibility of the owner.
Grounding	Unit MUST be grounded from branch circuit to unit, or through separate ground wire provided on permanently connected units. Be sure that branch circuit or general purpose outlet is grounded.
Wire Sizing	Use recommended wire size given in tables and install a single branch circuit. All wiring must comply with local and national codes. NOTE: Use copper conductors only.

CAUTION

Electric shock hazard.

Turn OFF electric power before service or installation.

All electrical connections and wiring **MUST** be installed by a qualified electrician and conform to the National Electrical Code and all local codes which have jurisdiction.

Failure to do so can result in property damage, personal injury and/or death.

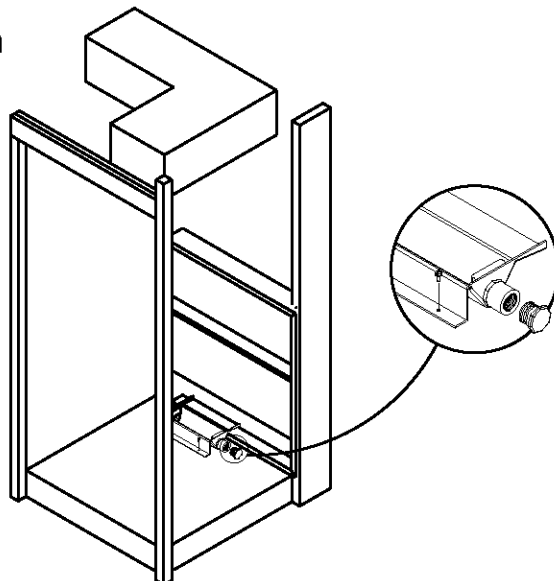

Figure 7
Drain Connection
and Location

**CAUTION**

THE ACCESSORY DRAIN PAN (VPDP1) MUST BE INSTALLED BEFORE INSTALLING THE UNIT.

1. The accessory drain pan has two (2) provisions (left & right) for connecting an external condensate drain.
2. A field supplied condensate drain system must be connected to one of the two 3/4" FPT connections.
3. The remaining connection must be plugged using the 3/4" pipe plug (provided) and field supplied teflon tape or pipe joint compound.
4. Failure to follow these procedures may result in serious property damage.

3) Electrical Data (continued)

Figure 8

Electrical & Thermostat Wiring Diagrams

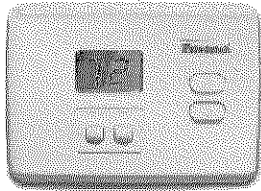

RT2
THERMOSTAT
(FRONT)

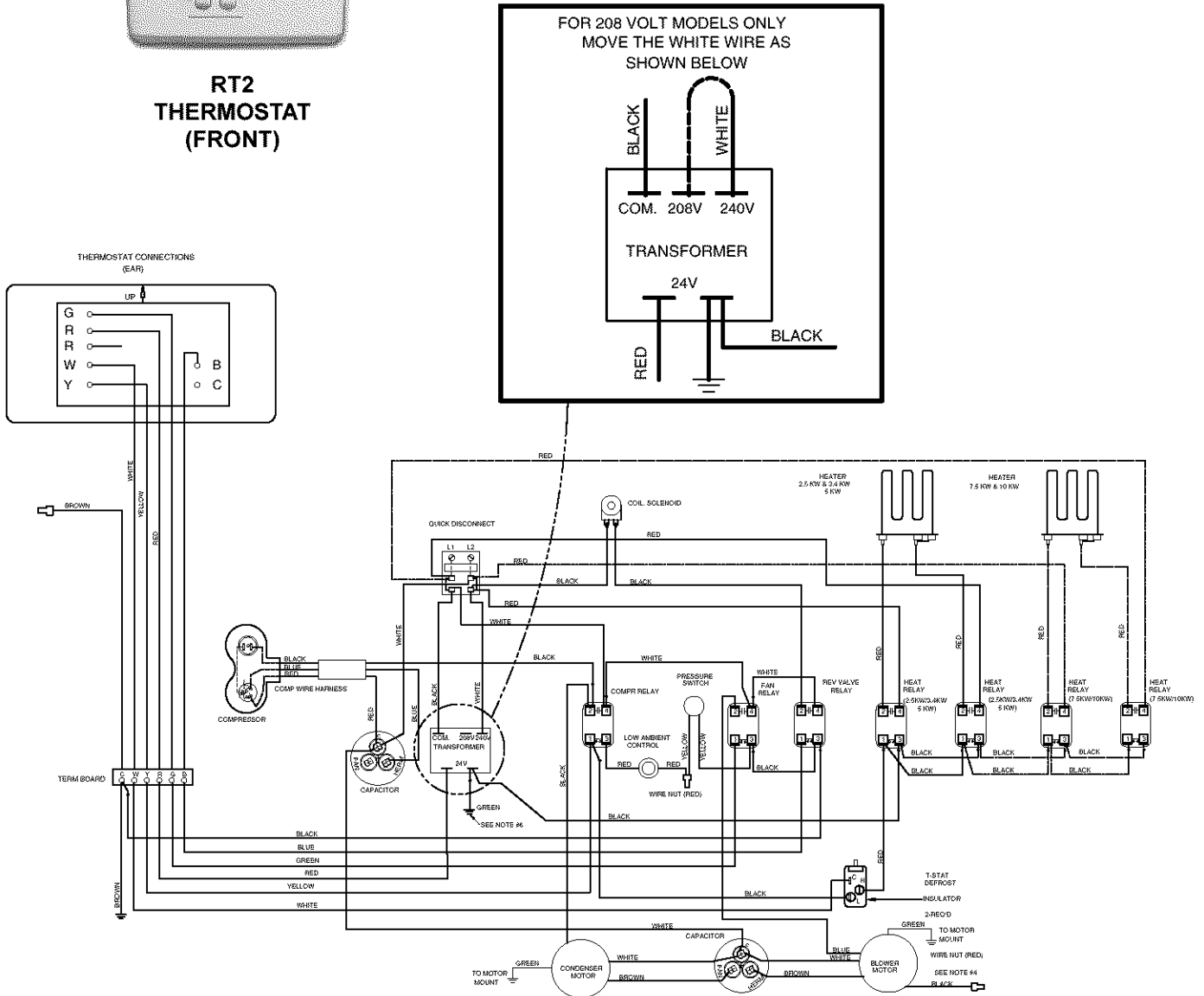

NOTE: THE DIAGRAM ABOVE ILLUSTRATES THE TYPICAL THERMOSTAT WIRING AND 208 VOLT TRANSFORMER WIRING. SEE THE UNIT CONTROL PANEL FOR THE ACTUAL UNIT WIRING DIAGRAM AND SCHEMATIC.

4) Indoor Return Air Grille Installation

There are three Indoor Return Air Grille options as shown in Figure 9. Choose the option that best suits your needs. Use the installation instructions provided with accessories for installation details.

Figure 9

Return Air Grille Options

Option 1

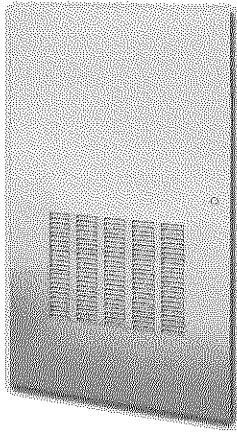

VPRG4

Return Air Grille with Access Panel

A field-supplied (25" x 20") filter is mounted inside the hinged access door.

Option 2

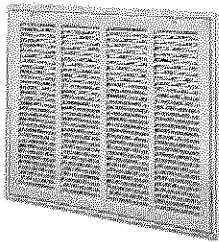

VPRG2

Return Air Grille

Unit requires a field-supplied access door or panel and a 16" x 20" filter.

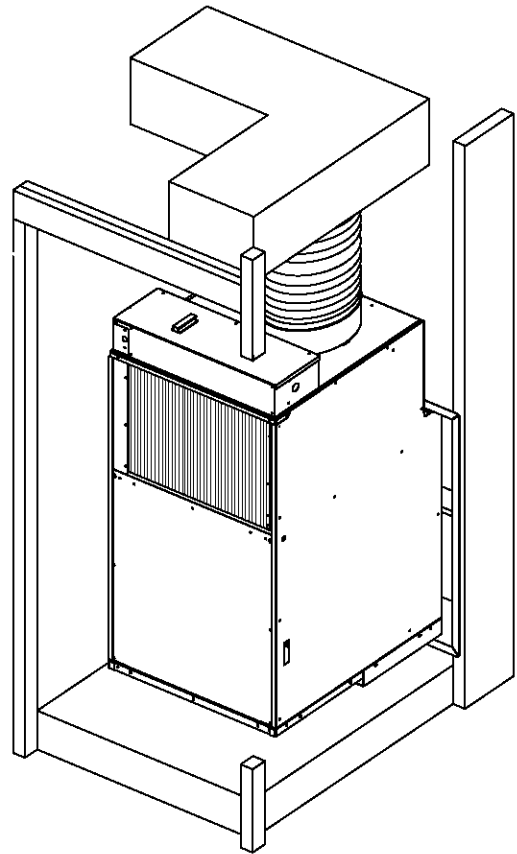

All Vert-I-Pak chassis are shipped with a 20" x 14" filter installed. If an accessory filter holder is to be used, you **MUST** remove the factory shipped filter from the chassis. Do **NOT** use two filters

Notes:

- A. These are the Friedrich recommended return air grille / filter / access panel arrangements. Consult the factory on other arrangements. Improper return air arrangements will cause performance problems.
- B. Return air arrangements are shown from the front, but can also be installed from the right or left side of the unit.

5) Indoor Airflow Data

The Vert-I-Pak A series units must be installed with a free return air configuration. The table below lists the indoor airflow at corresponding static pressures. All units are shipped from the factory and are rated at low speed.

To change to high speed replace the low speed lead (blue) with the high speed lead (black) on the blower relay.

	VEA/VHA24K	
	Low	High
.1" ESP	750	815
.2" ESP	725	780
.3" ESP	700	745
.4" ESP	675	700

All values listed are inches W.C. with a wet indoor coil with filter installed.

6) Chassis Installation

NOTE: Prior to installing the chassis, ensure that the drain pan and line are free from debris.

- Ensure that the wall plenum is installed in accordance with the VPAWP1-8/1-14 Installation Manual.
- Ensure that the VPDP1 drain pan is installed correctly (see page 8). Using the 3/4" plugs supplied with the pan, plug the unused condensate drain hole. Connect a drain to the condensate exit location. Be sure to use teflon tape or approved pipe sealant on all drain connections and plugs (see page 8).
- Place the chassis into the closet with the outdoor side facing the wall plenum opening.
- Slide the chassis into the wall plenum until the plenum divider seal is established and the factory-installed chassis to plenum gasket has sealed to the top flange of the plenum. (See Figure 10)

Figure 10
Slide-in View / Chassis Installation

The Vert-I-Pak chassis must be inserted into the wall plenum so that the plenum divider gasket makes contact with the condenser baffle in the unit. The chassis will fit approximately $2\frac{3}{8}$ " into the wall plenum.

NOTE: Prior to installing the chassis, ensure that the drain pan and line are free from debris.

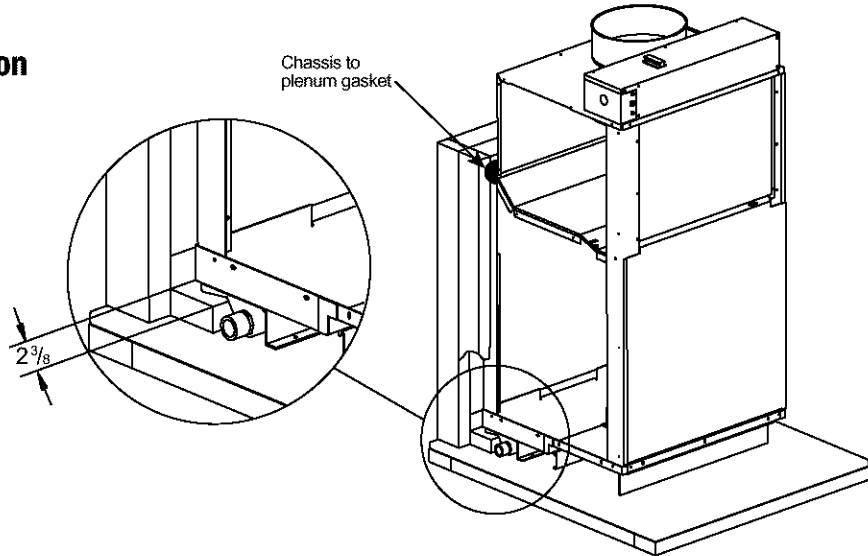

7) Chassis Final Connections

With the chassis in place, you are now ready to begin chassis connections:

- A. Move the thermostat switches to "OFF" and "AUTO." This will keep the thermostat from cycling the chassis until final connections are complete.
- B. Connect the ductwork onto the 10" collar. Plastic wireties (field supplied) are suggested to secure the ductwork in place. Use 2 wire ties, one for each inner and outer flex duct sleeve.
- D. For 208 Volt power only: you must move the transformer wire as shown in Figure 8, Page 9.
- E. Review the Final Installation Checklist on Page 12 before replacing the power quick disconnect, reconnecting power to the chassis, plugging in the remote thermostat harness, or operating the chassis.

WARNING

Electrical shock and moving parts hazard can cause injury or death. If you have not done so, pull out the disconnect head found on the front of chassis before continuing installation! Disconnect external power at the breaker.

8) Final Installation Checklist

- Correct line voltage?
- Chassis deck level?
- Plenum divider baffle installed?
- Wall plenum caulked? Level? Flashing?
- HACR type breaker/fuse?
- Single circuit only?
- Ductwork connected?
- Chassis weather seal in place?
- Wall thermostat wired correctly?
- Chassis inserted into plenum?

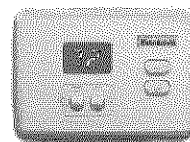

RT2 Digital Thermostat

III. Chassis Operation

9) Remote Thermostat Control

The chassis requires a simple single stage heat-cool wall thermostat. Each chassis comes with a terminal strip located in the electrical control box. All internal chassis wiring (low & high voltage) is factory ready for 230 Volt operation. For 208 Volt operation a single wire **MUST BE CHANGED ON THE TRANSFORMER**. Refer to Figure 8 on page 9.

10) Low Ambient Protection

Each chassis is equipped with Low Ambient Protection in the form of a suction line thermostat. This thermostat will prevent compressor operation at low suction line temperatures. Each chassis is also equipped with a factory installed bellows that will drain water from the base pan to prevent the fan slinger from freezing during winter weather.

11) Heating Defrost (Heat Pump Models Only)

All Heat Pumps have a passive heating defrost system. Defrost occurs as needed and automatically switches to electric heat during defrost. When the outdoor ambient temperature drops below a 45°F factory setting, the chassis automatically switches to electric heat. As outdoor ambient temperatures rise above 45°F, the chassis returns to the heat pump mode. The changeover temperature is user adjustable from approximately 32°F - 55°F. The defrost thermostat may also be used to lock out the compressor in an emergency heat situation.

12) Fresh Air Door

The Fresh Air Door is an "intake" system. The fresh air door is opened via a slide on the front of the chassis located just above the indoor coil. Move the slide left to open and right to close the fresh air door. The system is capable of up to 60 CFM of fresh air @ ~.3" H2O internal static pressure.

13) Condensate Disposal System

The VPDP1 drain pan features two ¾ female PVC fittings to attach a drain connection to on the left or right side of the drain pan. Condensate piping can be routed to the left, right or beneath the unit platform.

See page 8 or the drain pan installation manual for more information.

- Part 1:** The system's first stage increases energy efficiency utilizing a factory installed fan that slings the cold condensate onto the hot outdoor coil.
- Part 2:** When high outdoor humidity prevents the slinger from disposing of all the condensate, the excess condensate overflows into the condensate drain pan and out of the ¾" internal drain connections.
- Part 3:** If Parts 1 & 2 fail for any reason, excess condensate overflows from a spillway directly into the wall plenum to the outside of the building. **IF THIS OCCURS, THIS IS YOUR WARNING THAT THE CHASSIS OR DRAIN NEEDS SERVICING.**

IV. Service & Warranty

14) Servicing / Chassis Quick Changeouts

The chassis is designed for quick disconnect and change out. For minor electrical service, the control box cover lifts straight up after the screws & disconnect head are removed. For major electrical, refrigeration and fan service the chassis may be removed from utility closet.

To Remove the Chassis from the Closet:

- Switch the wall Thermostat off.
- Pull the Power Disconnect located in the front of the chassis.
- Disconnect the thermostat wiring harness.
- Disconnect the electrical connection.
- Disconnect the ductwork.
- Slide the chassis out of the wall plenum.
- Lift the chassis out of the utility closet.

WARNING

Electrical shock and moving parts hazard can cause injury or death. Pull out the disconnect head found on the front of the chassis before servicing.

15) Routine Maintenance

Performing Routine Maintenance

With the proper maintenance and care, your system will operate economically and dependably. Maintenance can be accomplished easily by referring to the following directions. However, before performing any maintenance, consider these important safety precautions:

WARNING: Electrical Shock Hazard. Before attempting any service work or routine maintenance, turn off all electrical connections to the unit. Failure to do so may result in property damage, personal injury and/or death.

CAUTION: Although great care has been taken to minimize sharp edges in the construction of your unit, be extremely careful when handling parts or reaching into the unit.

Replace Air Filter

A dirty air filter reduces the efficiency of your Vert-I-Pak and allows lint and dirt to accumulate on the indoor-air coil. Lint and dirt on the indoor-air coil can damage your unit and void the warranty. The air filter should be replaced as it becomes dirty.

To replace the filter (chassis mounted return air filter):

- Slide the filter clear of the filter rails.
- Remove the filter.
- Install new disposable filter.

CAUTION: Do not operate your system without a filter in place, nor block the front of the unit return air opening.

Inspect and Clean Indoor-air Coil

Eventually, minor amounts of lint and dirt may pass through the filter and collect on the indoor-air coil. These minor accumulations can be carefully vacuumed away with a brush attachment on a vacuum cleaner. Care must be taken to avoid bending the aluminum fins on the coil. Bent fins should be straightened using a special fin tool available from most HVAC service technicians.

Inspect Outdoor-air Intake and Exhaust

The unit's outdoor-air intake and outdoor-air exhaust paths must remain clear. Check the OA exhaust frequently. Keep it free of all debris, snow, or ice. The OA intake should also be kept free of obstructions. Blocking the OA exhaust or OA intake opening will reduce the efficiency of your unit, could damage it, and may void your warranty.

Inspect and Clean Condensate Drain

The condensate drain must be routed to a suitable drainage area. Check the unit condensate drain periodically. Keep it free of anything that may block or impede the flow of condensate water. If there is any accumulation of foreign matter in the drain pipe, it should be removed and cleaned. The entire drain line must be protected from freezing.

16) Warranty

All service work must be done by a qualified servicer. See Warranty on the next page, and consult your dealer or contractor for details



FRIEDRICH AIR CONDITIONING CO.
 Post Office Box 1540 · San Antonio, Texas 78295-1540
 (210) 357-4400 · FAX (210) 357-4480

VERT- I-PAK® A SERIES SINGLE PACKAGE VERTICAL AIR CONDITIONERS LIMITED WARRANTY

SAVE THIS CERTIFICATE. It gives you specific rights, you may also have other rights which may vary from state to state and province to province.

In the event that your unit needs servicing, contact your nearest authorized service center. If you do not know the nearest service center, ask the company that installed your unit or contact us - see address and telephone number below. To obtain service and/or warranty parts replacement, you must notify an authorized FRIEDRICH Air Conditioning Co. service center, distributor, dealer, or contractor of any defect within the applicable warranty period.

When requesting service: please have the model and serial number from your unit readily available.

Unless specified otherwise herein, the following applies:

FRIEDRICH VERT-I-PAK A SERIES VERTICAL AIR CONDITIONERS AND HEAT PUMPS

LIMITED WARRANTY - FIRST YEAR (Twelve (12) months from the date of installation). Any part found to be defective in the material or workmanship will be repaired or replaced free of charge by our authorized service center during the normal working hours; and

LIMITED WARRANTY - SECOND THROUGH FIFTH YEAR (Sixty (60) months from the date of installation). ON THE SEALED REFRIGERATION SYSTEM. Any part of the sealed refrigeration system that is defective in material or workmanship will be repaired or replaced free of charge (excluding freight charges) by our authorized service center during normal working hours. The sealed refrigeration system consists of the compressor, metering device, evaporator, condenser, reversing valve, check valve, and the interconnecting tubing.

These warranties apply only while the unit remains at the original site and only to units installed inside the continental United States, Alaska, Hawaii, Puerto Rico and Canada. The warranty applies only if the unit is installed and operated in accordance with the printed instructions and in compliance with applicable local installation and building codes and good trade practices.

For international warranty information, contact the Friedrich Air Conditioning Company - International Division.

Any defective part to be replaced must be made available to FRIEDRICH in exchange for the replacement part. Reasonable proof must be presented to establish the date of install, otherwise the beginning date of this certificate will be considered to be our shipment date plus sixty days. Replacement parts can be new or remanufactured. Replacement parts and labor are only warranted for any unused portion of the unit's warranty.



We will not be responsible for and the user will pay for:

1. Service calls to:
 - A) Instruct on unit operation. B) Replace house fuses or correct house wiring. C) Clean or replace air filters. D) Remove the unit from its installed location when not accessible for service required. E) Correct improper installations.
2. Parts or labor provided by anyone other than an authorized service center.
3. Damage caused by:
 - A) Accident, abuse, negligence, misuse, riot, fire, flood, or acts of God. B) Operating the unit where there is a corrosive atmosphere containing chlorine, fluorine, or any damaging chemicals (other than in a normal residential environment). C) Unauthorized alteration or repair of the unit, which in turn affects its stability or performance. D) Failing to provide proper maintenance and service. E) Using other than a "Seacoast Protected" unit in a coastal environment. F) Using an incorrect power source. G) Faulty installation or application of the unit.

We shall not be liable for any incidental, consequential, or special damages or expenses in connection with any use or failure of this unit. We have not made and do not make any representation or warranty of fitness for a particular use or purpose and there is no implied condition of fitness for a particular use or purpose. We make no expressed warranties except as stated in this certificate. No one is authorized to change this certificate or to create for us any other obligation or liability in connection with this unit. Any implied warranties shall last for one year after the original purchase date. Some states and provinces do not allow limitations on how long an implied warranty or condition lasts, so the above limitations or exclusions may not apply to you. The provisions of this warranty are in addition to and not a modification of or subtraction from the statutory warranties and other rights and remedies provided by law.

In case of any questions regarding the provisions of this warranty, the English version will govern.

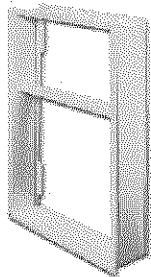
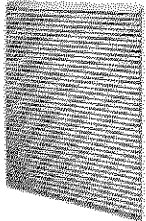
IV. Vert-I-Pak Accessories

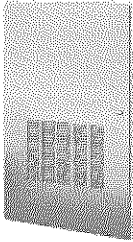
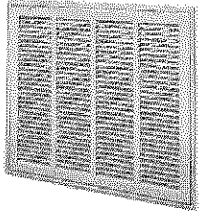
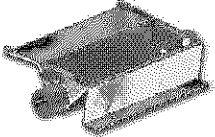
MODEL	DESCRIPTION	PHOTO
VPAWP1-8	<p>WALL PLENUM Two-part sleeve that telescopes in and out from 5 1/2" to 8" in depth. The wall plenum sits inside the exterior wall penetration.</p> <p>DIMENSIONS: 30 3/8" high x 24 1/8" wide. CUTOUT DIMENSIONS: 30 7/8" high x 24 5/8" wide.</p>	
VPAWP1-14	Same as VPAWP1-8, but telescopes 8" to 14" as required.	
VPAL2	<p>ARCHITECTURAL LOUVER Extruded aluminum louver that attaches to the outdoor section of the wall plenum.</p> <p>DIMENSIONS: 31 1/16" high x 25 9/16" wide.</p>	
VPSC2	Same as VPAL2 but can be ordered in a special color to match the exterior wall.	
RT2	<p>DIGITAL THERMOSTAT Digital electronic thermostat with "one touch" adjustment. Mounts to wall for control of unit.</p>	
VPRG4	<p>ACCESS PANEL / RETURN AIR GRILLE – Serves as an access panel to chassis and interior return air grille. A field-supplied (25" x 20") filter is mounted inside the hinged access door.</p> <p>DIMENSIONS: 58" high x 29" wide. CUTOUT DIMENSIONS: 55 3/4" high x 27" wide.</p>	
VPRG2	<p>RETURN AIR GRILLE – Interior return air grille that hinges to allow a field supplied (16" x 20") filter to slip inside. Must be used when an access door / panel already exists in closet.</p> <p>DIMENSIONS: 18 7/16" high x 22 3/8" wide.</p>	
VPDP1	<p>DRAIN PAN for VEA/VHA24 models. Drain pan may be installed prior to chassis for easy installation/removal.</p>	

Use Factory Certified Parts.

Friedrich®

FRIEDRICH AIR CONDITIONING CO.

Post Office Box 1540 · San Antonio, Texas 78295-1540
4200 N. Pan Am Expressway · San Antonio, Texas 78218-5212
(210) 357-4400 · Fax (210) 357-4480
www.friedrich.com

Printed in the U.S.A.

920-159-01 (10-03)