



WallMaster® PTAC

Packaged Terminal Air Conditioners & Heat Pumps

- Standard
- Remote Thermostat
- Seacoast Protected

Installation & Operation Manual

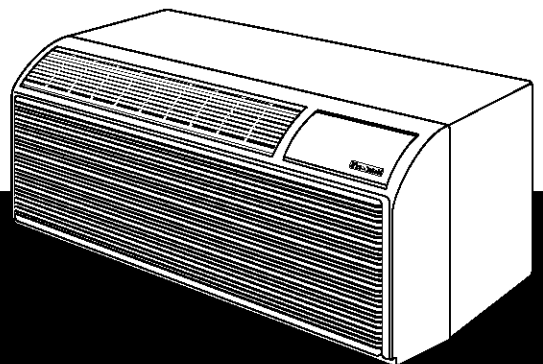
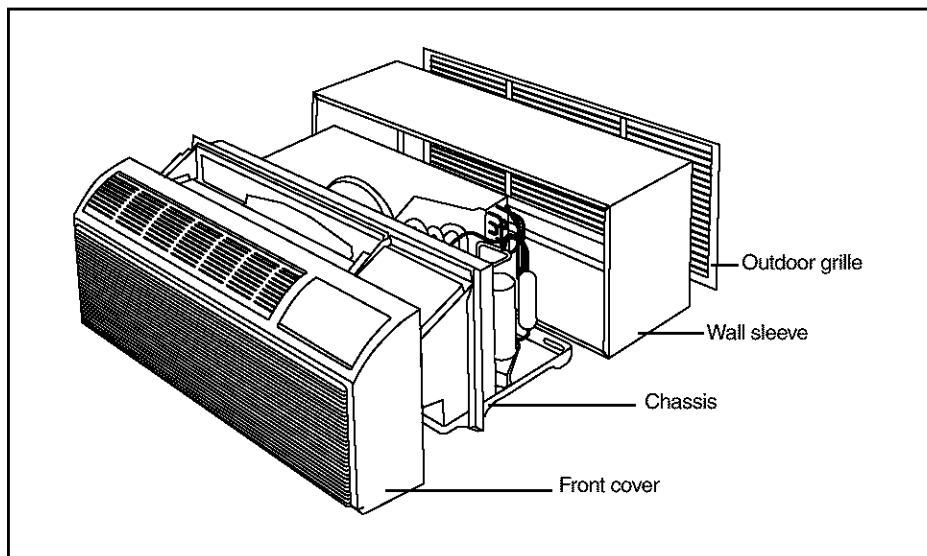

Table of Contents

Unit Components	2
P-Series Announcement/Model Number Code.....	3
Installation Recommendations	4
Drain Kit Installation	5-6
Wall Sleeve Installation.....	7-8
Deep Wall Installation	9
Standard Grille Installation.....	10
Installation Checklist	11
Electrical Rating Tables.....	11
Chassis Installation	12-13
Standard Unit Operations	14
Temperature Limiting Thermostat	14
Heating Control (Heat Pumps & Emergency Heat).....	15
Fan Cycle Switch	15
Fresh Air Vent Control.....	15
Air Discharge Grille	16
Start-up Checklist.....	16
Appendix A: Remote Thermostat Wiring	17-18
Appendix B: Electrical Wiring for 265 V Models.....	19
Routine Maintenance.....	20
Basic Troubleshooting Techniques	21
Accessories	22-23
Warranty	24

Typical Unit Components



Friedrich®

Announcing the Friedrich P-Series Packaged Terminal Air Conditioner.

A new approach to reliability and efficiency. A totally redesigned Friedrich PTAC.

Thank you for your decision to purchase the newly designed Friedrich Packaged Terminal Air Conditioner (PTAC). We are confident that you will find this unit a quiet and efficient example of Friedrich reliability.

This Installation and Operation Manual has been designed to insure maximum satisfaction in the performance of your unit. For years of trouble-free service, please follow the installation instructions closely. We cannot overemphasize the importance of proper installation. We have added new information to the basic instructions to help you achieve success.

Remember, proper installation is not difficult but it is essential.

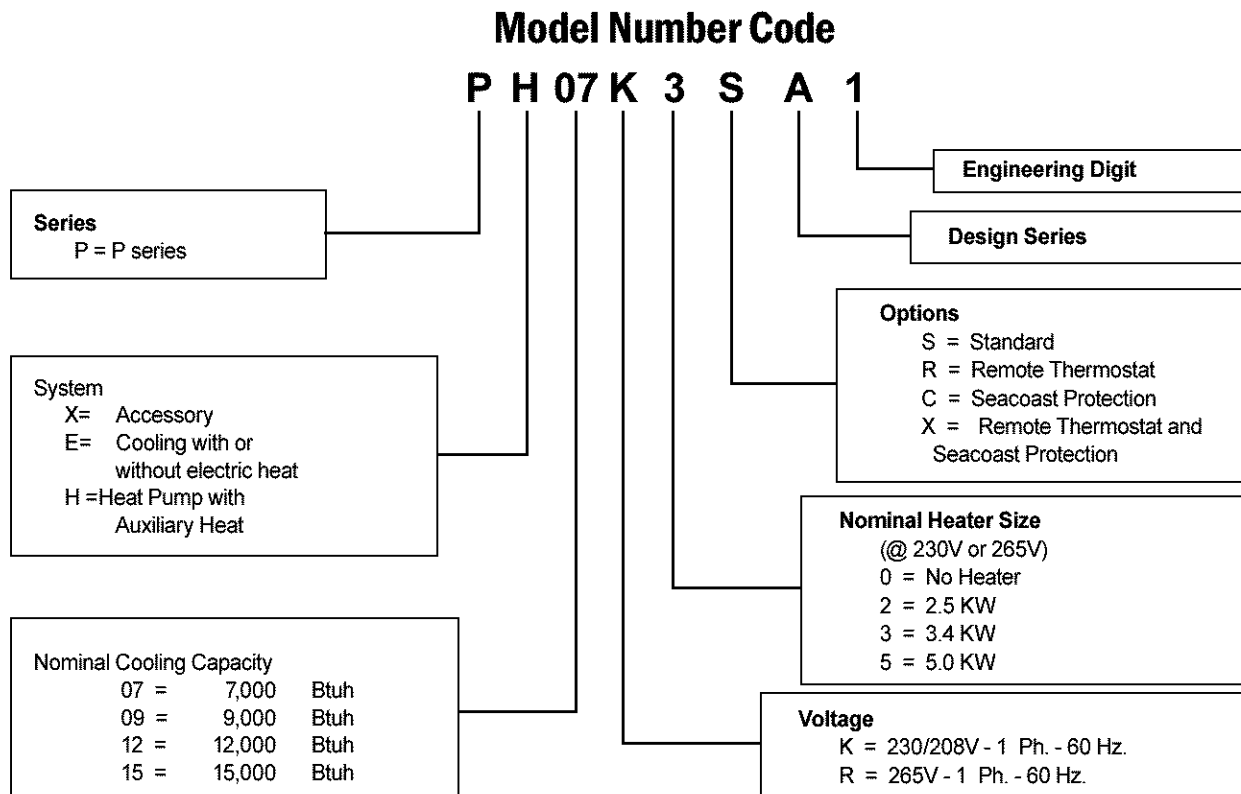

Please read this manual thoroughly prior to equipment installation or operation. It is the installer's responsibility to properly apply and install the equipment. Installation must be in conformance with the NFPA 70-2002 National Electric Code or current edition and Universal Mechanical Code current edition and applicable local or national codes.

PTAC Installation Recommendations

For proper PTAC unit performance and maximum operating life please refer to the minimum installation clearances below:

Figure 1

PTAC units should be installed no closer than 12" apart when two units are side by side. If three or more PTAC units are to operate next to one another allow a minimum of 36" between units. Also, a vertical clearance of 60" should be maintained between units installed.

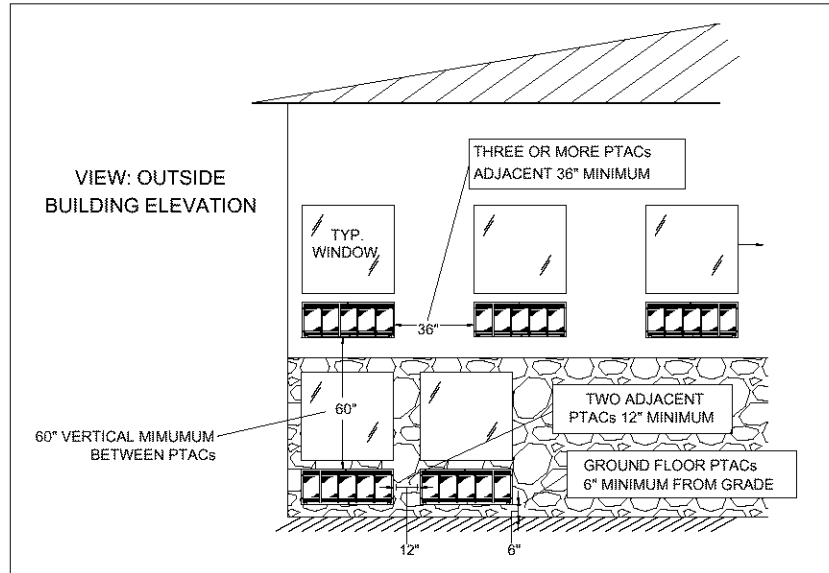
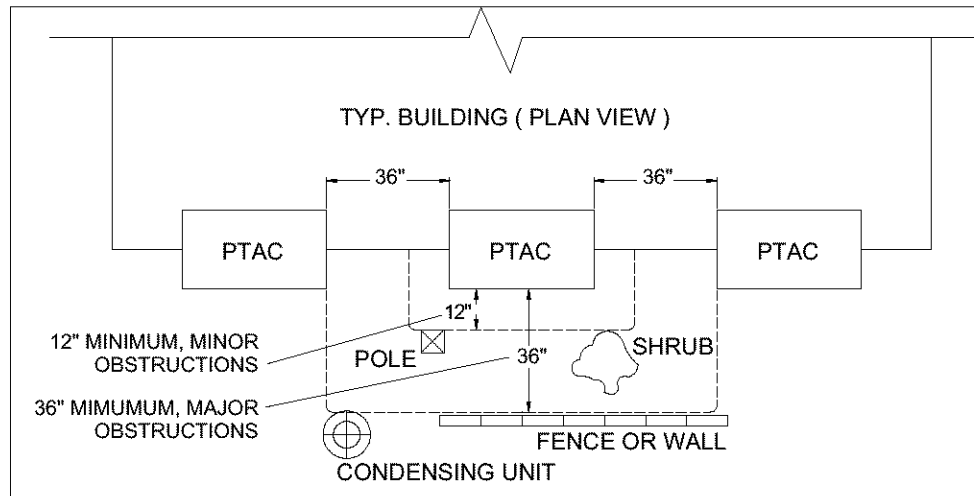

Figure 2

For PTACs on the ground floor or anytime obstructions are present, use the following guidelines:

- For minor obstructions such as lamp poles or small shrubbery a clearance of 12" from the outdoor louver should be maintained.
- For major obstructions such as a solid fence, wall or other heat rejecting device like a condensing unit, a minimum distance of 36" should be kept.



The above suggestions are for reference only and do not represent all possible installations. Please contact the factory for information regarding affects of other installation arrangements. By following these simple recommendations you can be confident that your Friedrich PTAC will provide years of worry free operation.

Installation Instructions PXDR10 Drain Kit

NOTE: Determine whether drain will be located within the wall, on the indoor side, or will drain to the exterior of the building. Follow appropriate instructions below depending on your particular type of installation.

Internal Drain (optional for new construction)

NOTE: If installing an internal drain, you **MUST** install a drain kit on the wall sleeve before the wall sleeve is installed.

1. Refer to Figure 3 below and locate the drain within the "Primary" area for best drainage. Maintain at least a 1/2" clearance from the embossed area.
2. Using the mounting plate with the 1/2" hole as a template, mark and drill two, 3/16" mounting holes and a 1/2" drain hole.
3. Remove the backing from the gasket and mount it on the flat side of the mounting plate. (See Figure 4.) Insert the drain tube through the hole in the gasket and mounting plate so the tube flange will be against the wall sleeve.
4. Position the assembly beneath the drilled holes and secure it with #10-24 x 1/2" machine screws and lock nuts provided. Seal the tops of the screws with silicone caulking.
5. Use 1/2" I.D. copper tube, PVC pipe, or vinyl hose (obtained locally) to connect the internal drain tube to the drain system in the building.
6. Referring to Detail A on page 6, locate and assemble the (2) two cover plates and gaskets over the drain holes at the rear of the wall sleeve. Attach them with the #10 sheet metal screws provided. Make certain that the four overflow slots at the rear of the wall sleeve are not blocked (See drawing of the back of the sleeve on page 6).
7. If a deep wall extension (PXWE) is used, after installing the field supplied flashing, caulk as required. Be sure to caulk around the flashing and the wall sleeve where the hole was drilled for the drain tube.

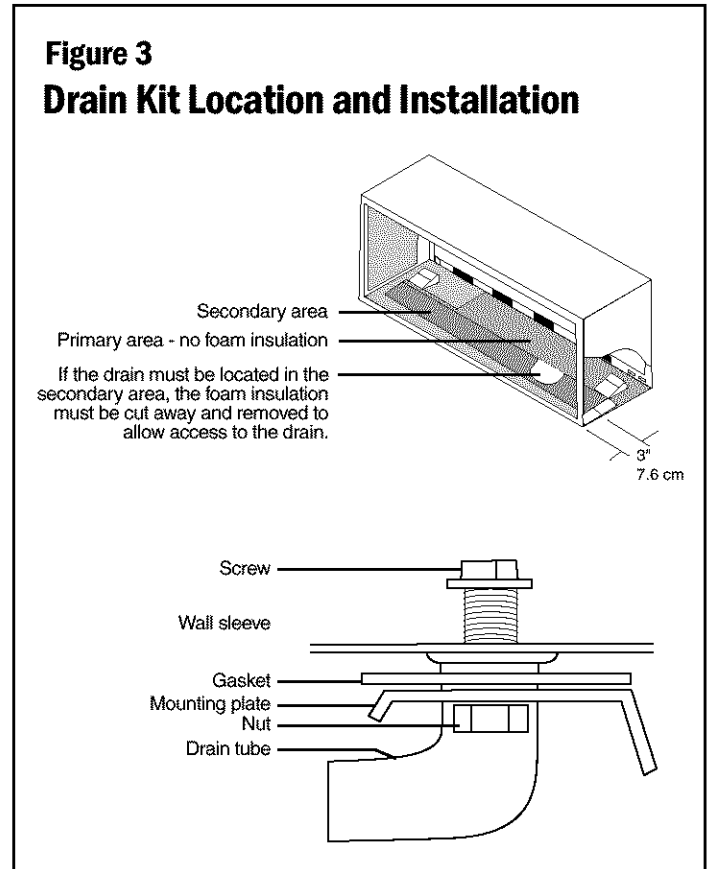

External Drain (for new construction or unit replacement)

When using an external drain system, the condensate is removed through either of two drain holes on the back of the wall sleeve. Select the drain hole which best meets your drainage situation and install the drain kit. Seal off the other with a cover plate.

Drain Tube Installation

1. Peel the backing tape off the gaskets and apply the sticky side to one cover plate and one mounting plate as shown in Details A and B.
2. Place the drain tube through the gasket and the mounting plate with the flange toward the wall sleeve.
3. Attach the drain tube assembly to one of the two drain holes at the rear of the wall sleeve. The large flange on the mounting plate is positioned at the bottom of the sleeve facing toward the sleeve, Detail B. When the drain tube is positioned at the desired angle, tighten the screws.

NOTE: If the wall sleeve has not been installed, the drain tube must be rotated to a horizontal position until after the sleeve is installed. Tighten the mounting plate screws when the tube is in the proper position. Make certain that the four overflow slots at the rear of the wall sleeve are not blocked. (See the drawing below.)

Cover Plate Installation

4. Mount the foam gasket to the cover plate. Using two #10 x 1/2" sheet metal screws (provided), attach the cover plate to the remaining drain hole. Make certain the large flange on the plate is positioned at the bottom of the sleeve.
5. Discard the additional cover plate, gasket, machine screws, and locknuts.

PXDR10	
QUANTITY	DESCRIPTION
2	COVER PLATES
1	MOUNTING PLATE
1	DRAIN TUBE
3	MOUNTING PLATE GASKETS
4	#10 X 1/2" MOUNTING SCREWS
2	10-24 X 1/2" MACH. SCREWS
2	LOCKNUTS

Figure 4

Drain Kit Installation

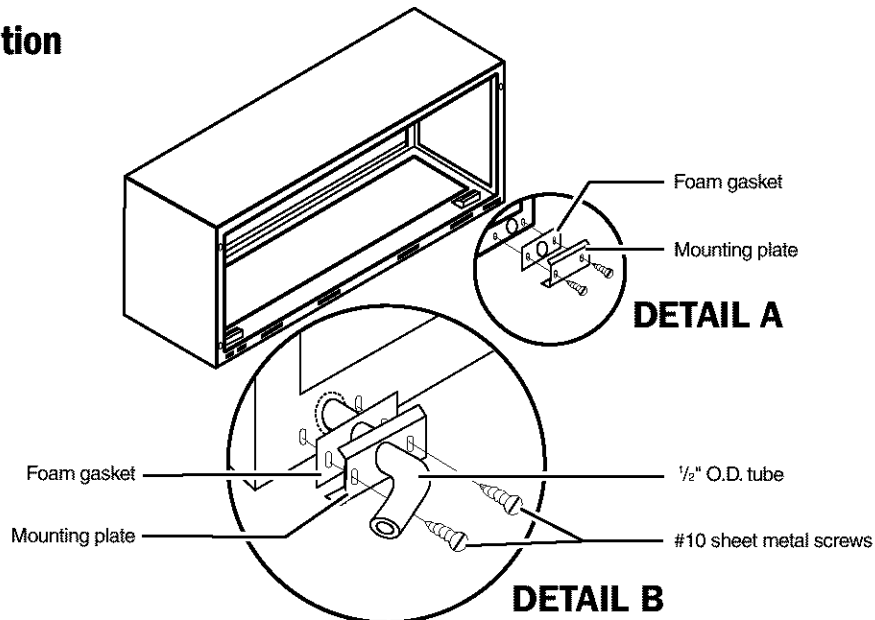

NOTES:

The large flange on the mounting plate is positioned at the bottom of the sleeve facing toward the sleeve. The drain tube must be rotated to a horizontal position to allow for the wall sleeve to be installed into the wall. Once the wall sleeve is installed, return the drain tube to a downward angle.

Wall Sleeve Installation Instructions (PXWS)

NOTE: Insure that the unit is only installed in a wall structurally adequate to support the unit including the sleeve, chassis and accessories. If the sleeve projects more than 8" into the room, a subbase or other means of support MUST be used. Please read these instructions completely before attempting installation.

Figure 5

Typical Wall Sleeve Installation

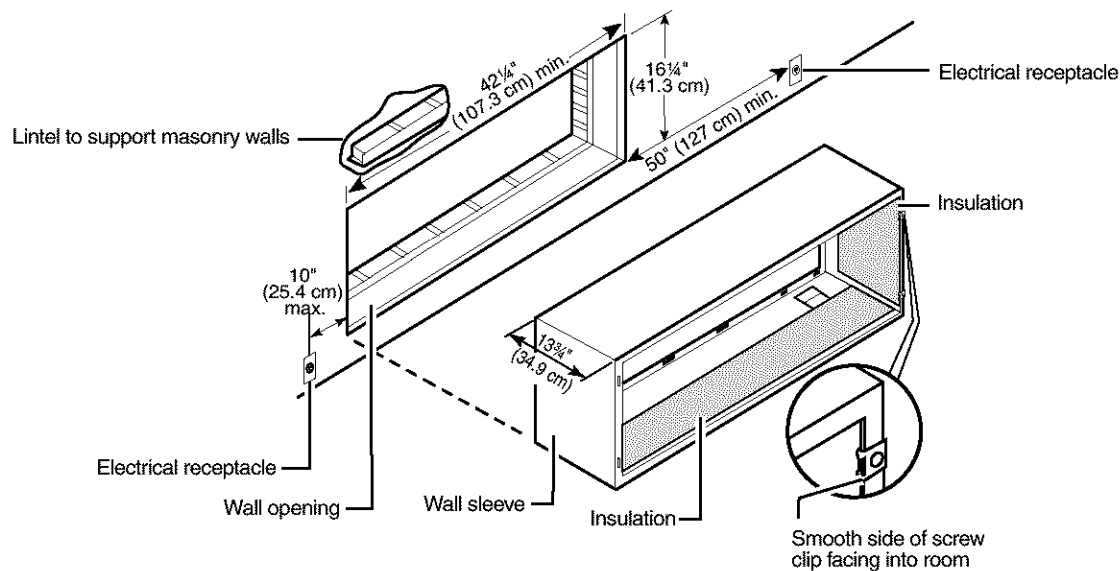

For Deep Wall Installation See Section II

The following instructions apply ONLY to walls less than 13 1/4" in depth.

1. From inside the building, position the wall sleeve in the opening and push it through the wall so it protrudes at least 1/4" on the outside, note Figure 5.
2. Position the wall sleeve with a slight tilt towards the outside to facilitate condensate drainage. It should be level side-to-side and the front should be 1/4" higher than the back. DO NOT allow any pitch toward the inside.



WARNING

Electrical shock hazard.

Turn electric power OFF at the fuse box or service panel before making any electrical connections and ensure a proper ground connection is made before connecting line voltage. Failure to do so can result in property damage, personal injury and/or death.

Figure 6
Dimensions

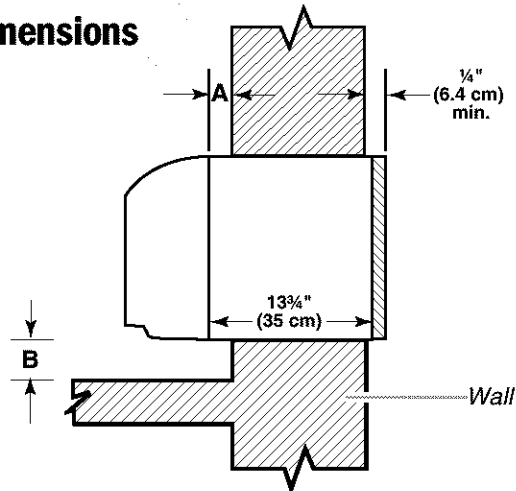

Dimension*	A	B	
	Allow for wall finishing (Minimum)	Allow for floor finishing Min.	Max
No Accessories	1/4" (6.4 mm)*	1/4" (6.4 mm)	---
With Subbase	1 3/4" (4.5 cm)	3 1/2" (8.9cm)	5" (12.7cm)
With Lateral Duct	3/4" (1.9 cm)	1/4" (6.4 mm)	---

* If more than one accessory is to be used, use the maximum dimension. If the wall thickness is more than 13 3/4" (35cm) - (A + 1/4" [6.4 mm]), a sleeve extension must be used.

- Drill two 3/16" holes through each side of the sleeve approximately 4" from top and 4" from bottom of sleeve. Screw four #10 x 1" screws (included) or appropriate fasteners for your installation, through the holes in the sides of the wall sleeve.
- Apply sealant around the wall sleeve where it projects through the inside and outside wall surfaces. Apply the sealant to the screw heads or the tops of the fasteners used in Step #3.
- If the chassis and exterior grille are to be installed later, leave the weatherboard and center support in place, otherwise remove and dispose of them.
- Provide a support lintel if the wall sleeve is installed in a concrete or masonry wall. (See Figure 7.)

NOTE: When sealing the sleeve on the outside of the building, be careful NOT to let the sealant block the two condensate drain holes or the four overflow slots at the bottom flange of the sleeve.

Figure 7
Lintel Installation

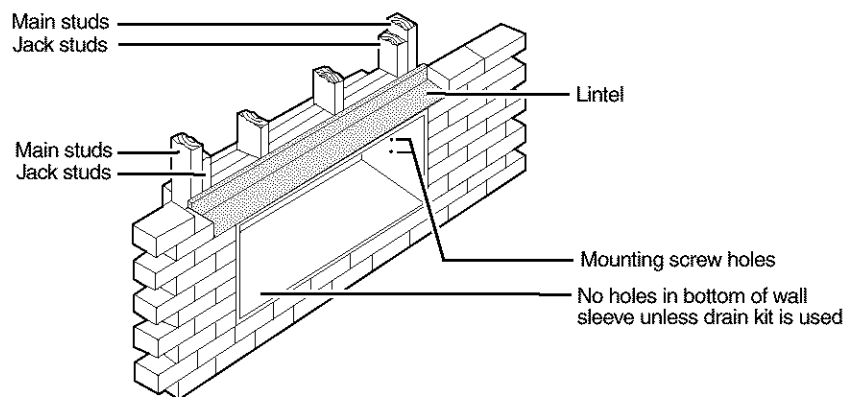

NOTE: Construct wall opening to comply with all applicable building codes.

Section II – Deep Wall Installation (PXWE)

If the wall is thicker than allowed in the notes in Figure 6, a sheet metal wall sleeve extension and flashing **MUST** be used.

Installation Instructions for the PXWE – 4" Wall Sleeve Extension

The following points **MUST** be considered when installing a wall sleeve extension:

1. Provision must be made to direct excess condensate from the back of the wall sleeve into the extension then outside the building or to a drainage system.
2. Air baffles must be mounted to properly direct air flow to and from the condenser.
3. The wall sleeve extension design must allow for the proper mounting of the grille.
4. Caulking is required at all sites where condensate or external water could potentially infiltrate into the building.
5. Fabricate and install metal flashing in wall to serve as a drip panel. Refer to drawing for more information.

6. Condensate notches and overflow slots must be kept clear of sealant and gaskets so condensate can flow freely into the wall sleeve extension.

NOTE: Improper fabrication or installation of a wall sleeve extension will impair PTAC performance.

Extension Installation

Secure the wall sleeve extension to the wall sleeve before installing it in the wall. Refer to Figure 8 for a guide for fabrication of a condensate drip panel. The panel **MUST** extend the full depth of the wall sleeve and the wall sleeve extension.

Pay particular care in sealing and caulking the panel where it makes contact with the wall sleeve (see Figure 8). After installation in the wall, secure with fasteners through the sides. Use a good grade of silicone sealant around the sleeve extension. Seal all exposed screw heads. When the installation is complete, the outside grille should be attached to the wall sleeve extension.

Figure 8

Wall Sleeve Extension Sealant Locations

(A)

IMPORTANT NOTE: The silicone bead **MUST** extend 3" up the side of the two flanges to prevent condensate from leaking.

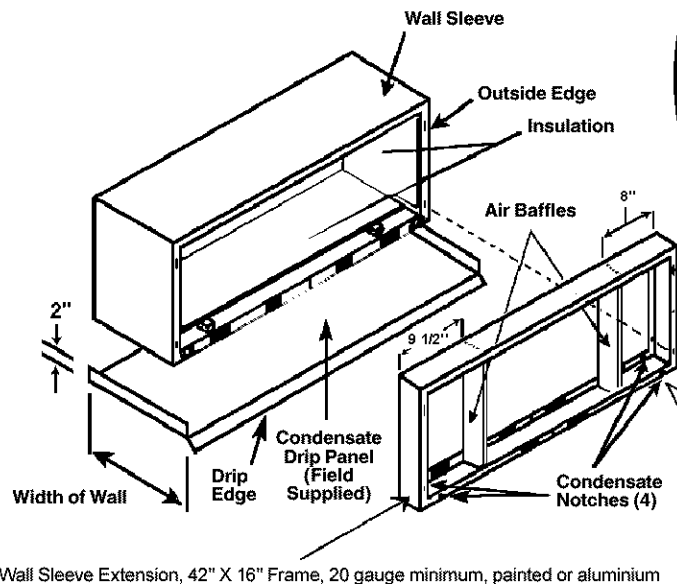

SEALANT LOCATIONS

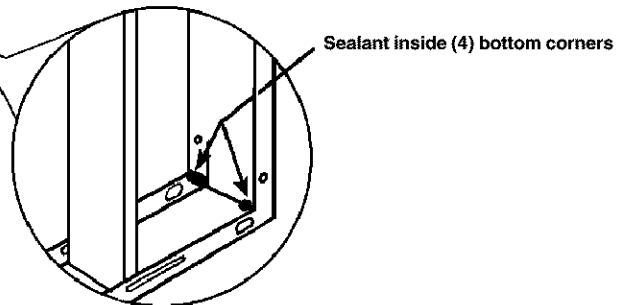
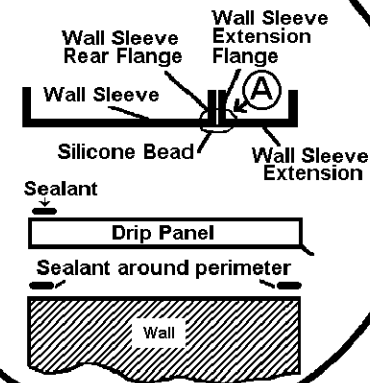

Installation Instructions Model PXGA Standard Grille

1. Remove the center support and weatherboard if still installed in the sleeve.
2. Insert six plastic grommets into the grille openings from the outside of the grille as shown in Figure 9.
3. Insert two #8 x 3/8" sheet metal screws (provided) in the top two outside edge plastic grommets, and tighten them half way into the grommets.
4. **CAUTION:** Bodily injury can be caused by grilles falling from a building during installation. It is recommended that a safety line be attached to the grille and an anchor point inside the building during installation.
5. Grasp the grille by the attached plastic handles. Position it with the condensate drain knockouts facing down. From inside the building, maneuver the grille through the wall sleeve and pull toward you until the screw heads are inserted into the keyhole slots at the top of the wall sleeve. Tighten the two screws completely.
6. Insert the remaining screws into the remaining holes and tighten securely.

PXGA	
Quantity	Description
1	Stamped Aluminum Grille
6	Plastic Grommets
6	#8 x 3/8" Sheet Metal Screws

Figure 9

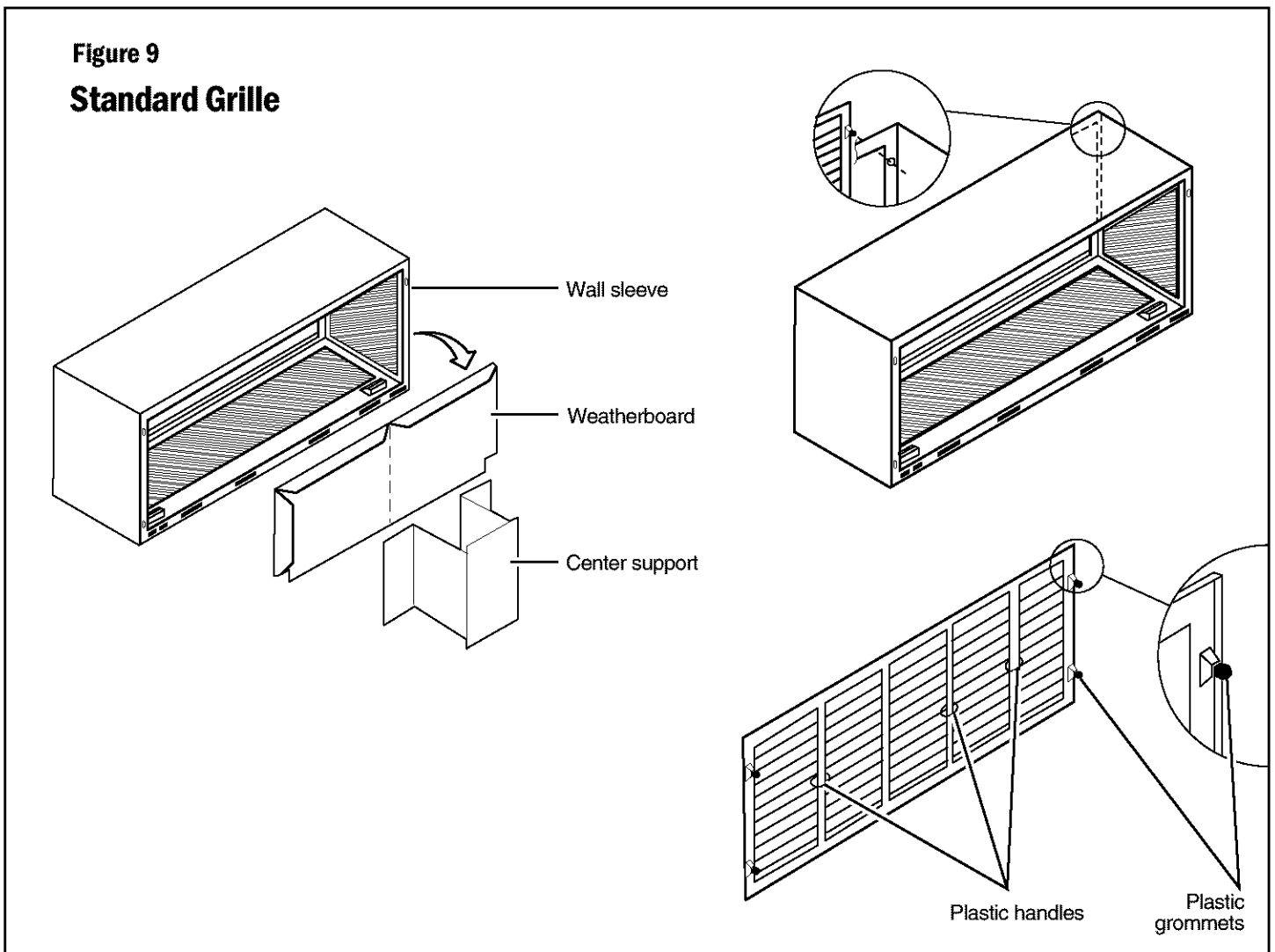



A. Installation Checklist

- Inspect all components and accessories for damage before and after installation.
- Remove the cardboard wall sleeve support and grille weatherboard.
- Check for proper wall sleeve installation in accordance with the wall sleeve installation instructions.
- Check installation of the wall sleeve foam gasket.
- Check for a subbase kit or other means of structural support which is required for ALL installations projecting more than 8" into room.
- Install the recommended Condensate Drain Kits for complete condensate removal.
- Ensure that the chassis is installed in a 16" high x 42" wide wall sleeve that is no deeper than 13 3/4". A baffle kit is required if the sleeve exceeds that depth.
- Ensure that drapes, bed, bedspread, furniture, etc. DO NOT block either return or discharge air grilles.
- Inspect the condenser air inlet and outlet for any obstructions (shrubbery, etc.)

B. Electrical Rating Tables

All 230/208 volt units are equipped with power cords. See Appendix B on page 19 for wiring instructions on 265V units.

NOTE: Use Copper Conductors ONLY. Wire sizes are per NEC, check local codes for overseas applications.

AMPS	15	20 *	30
RECEPTACLE			
MANUFACTURER	PART NUMBERS		
Hubbell	5661	5461	9330
P & S	5661	5871	5930
GE	GE4069-1	GE4182-1	GE4139-3
Arrow-Hart	5661	5861	5700
TIME-DELAY TYPE FUSE (or HACR circuit breaker)	15	20	30

HACR – Heating, Air Conditioning, Refrigeration
 * May be used for 15 Amp applications if fused for 15 Amp
 NOTE: 265 volt units are hard wired.

Nameplate maximum circuit breaker size	AWG Wire size**
15	14
20	12
30	10

AWG – American Wire Gauge

* Single circuit from main box

** Based on copper wire, single insulated conductor at 60°C



Electric shock hazard.

Turn off electric power before service or installation.

All electrical connections and wiring MUST be installed by a qualified electrician and conform to the National Electrical Code and all local codes which have jurisdiction.

Failure to do so can result in property damage, personal injury and/or death.

Wire Size	Use ONLY wiring size recommended for single outlet branch circuit.
Fuse/Circuit Breaker	Use ONLY type and size fuse or HACR circuit breaker indicated on unit's rating plate. Proper current protection to the unit is the responsibility of the owner. NOTE: A time delay fuse is provided with 265V units.
Grounding	Unit MUST be grounded from branch circuit through service cord to unit, or through separate ground wire provided on permanently connected units. Be sure that branch circuit or general purpose outlet is grounded. The field supplied outlet must match plug on service cord and be within reach of service cord. Refer to Table 1 for proper receptacle and fuse type. Do NOT alter the service cord or plug. Do NOT use an extension cord.
Receptacle	The field supplied outlet must match plug on service cord and be within reach of service cord. Refer to Table 1 for proper receptacle and fuse type. Do NOT alter the service cord or plug. Do NOT use an extension cord.
Wire Sizing	Use recommended wire size given in Table 2 and install a single branch circuit. All wiring must comply with local and national codes. NOTE: Use copper conductors only.

Section III – Chassis Installation

*** Check to be sure the wall sleeve, extension (if used), grille, and drain kit are installed properly before chassis installation**

1. Remove the weatherboard and center support from the sleeve (if still in place). Be sure an outdoor grille is attached.

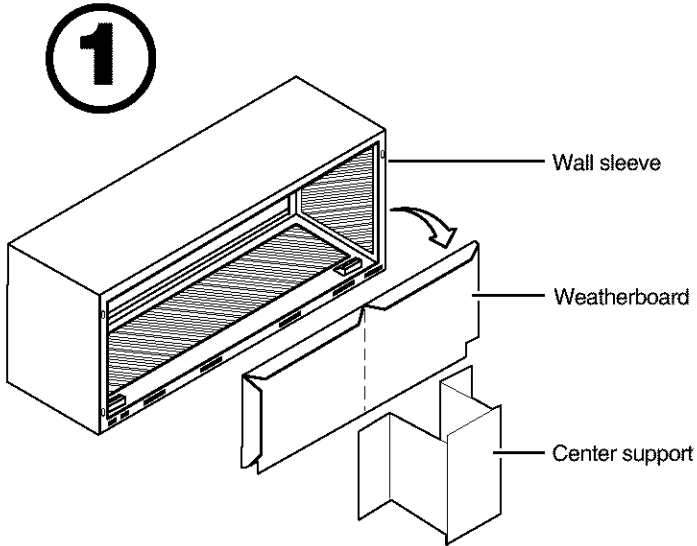

NOTE: To avoid breaking the door or hinge pins, do not apply excessive force when installing

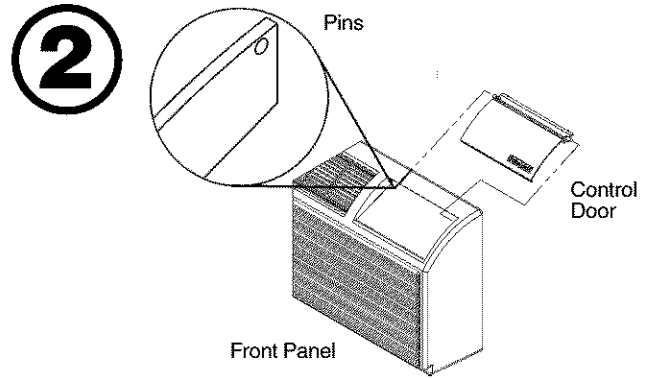

3. Remove the two chassis shipping brackets from the ends of the shipping pallet.

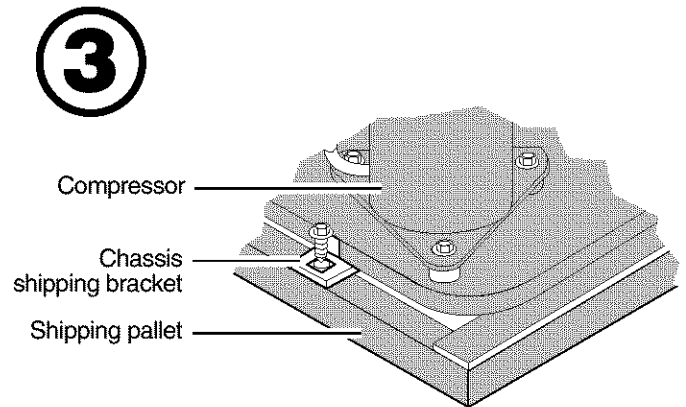

IMPORTANT: Use a wall sleeve adapter kit (PXSE) if installing a P-Series chassis in a T-Series sleeve.

WARNING

Suffocation hazard

Keep bag away from babies and children.

Do NOT use in cribs, beds or playpens. Destroy immediately after opening. This bag is NOT a toy.

Failure to do so can result in personal injury and/or death

2. Remove the front cover contained in a protective plastic bag from chassis. Remove the bag and dispose of it properly.

If the control door is not installed, follow these steps:

- From the front of the cover, slide the right control door pin into the hole on the right side of the front cover. Slide the left door pin into the hole on the left side of the front cover opening and snap it into place.

IMPORTANT: When installing a Friedrich P-Series PTAC into an existing sleeve, it is important to ensure that the unit is installed completely. Inspection of the air seal between the condenser air baffles and around the indoor mounting flange is recommended. In some cases additional gaskets or baffling may be required.

4. Center the chassis in the pre-installed sleeve and carefully push the chassis until the chassis flange and gasket contact the sleeve flange.

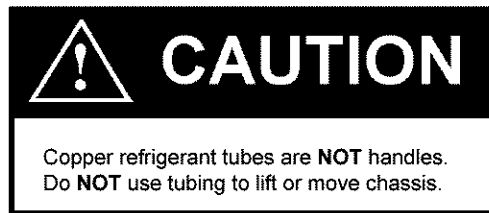
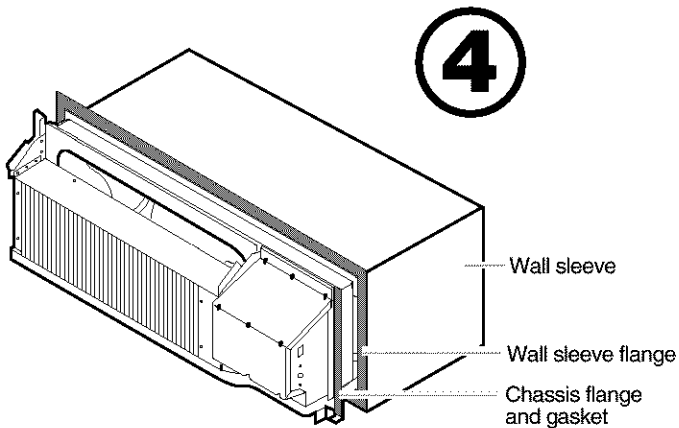

NOTE: If the unit is mounted flush to the floor, the service cord **MUST** be rerouted at the bottom of the front cover on the side closest to the receptacle. A notch **MUST** be made in the front cover side where the cord exits the unit. It is the responsibility of the installer to create an exit notch. See diagram 8 for suggested opening size and placement.

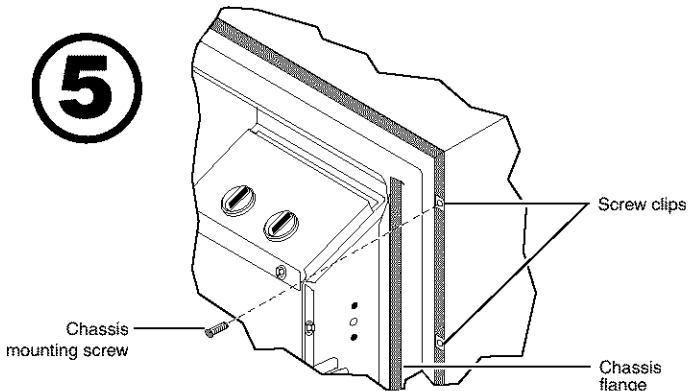

5. Locate the four #10 x 1" chassis mounting screws. Tighten the screws into the clips - adjacent to the alignment dimples on the mounting brackets on the wall sleeve flange (two per side).
6. Install the front cover assembly (including the discharge grille) by placing the top of the cover onto the 90° angle bracket along the top of the chassis. Rotate the bottom into place and insert the included thumb screws into the slots located

at the bottom back corners of the cover. Tighten them into the quick nuts located on the chassis to secure the cover. If the unit has been placed such that there is no room to insert the thumbscrews from the bottom, request a Side Mounting kit (Part No. PXSM) from Friedrich. Locate the service cord or conduit in the notch at the bottom right of the front cover.

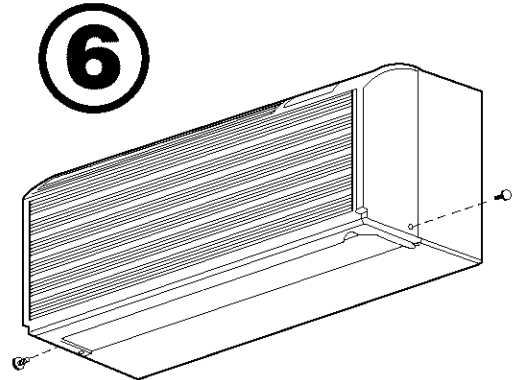

7. If the filters are not already installed in tracks in the plastic cover, slide them into place.
8. Plug the cord (if applicable) into the appropriate receptacle. Extra cord may be coiled inside the front cover behind the return air grille. Restore power to the unit.

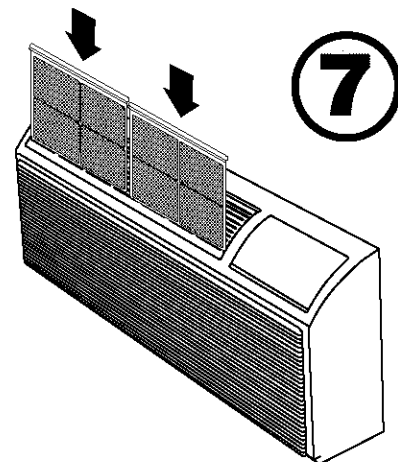

To remove the front cover, remove the thumbscrews at the bottom back corners of the cover (or sides). Pull the bottom end forward and lift it up to clear the L bracket across the top of the chassis.

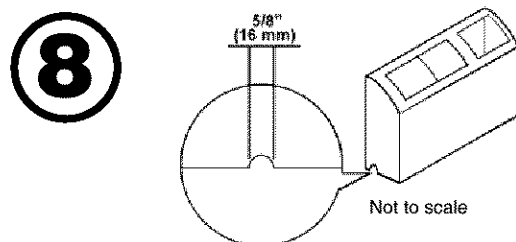

If a remote thermostat is to be installed, proceed to Appendix A, Step 1. For a 265 V unit, proceed to Appendix B, Step 1.

C. Standard Unit Operation

Rotate the temperature dial in small increments in the warmer or cooler direction. Moving the dial more than 1/4" at a time may overcompensate and result in an extreme hot or cold situation.

- If a remote thermostat is installed, see Appendix A, page 18-20.

Rotary Switch Operation	
Control	Operation
Temperature	The full-range thermostat maintains room temperature at the desired setting in both the heating and cooling modes. Turn the dial counterclockwise for warmer and clockwise for a cooler temperature.
Low and High Cool	Operates the unit on cooling. Cooling will not begin if the room temperature is below 60°F.
Low and High Heat	Operates the unit on heating. Some models do not provide this selection.
Fan Only	Circulates air within the room at high fan speed only. No heating or cooling functions are active.

Standard Unit Control Panel

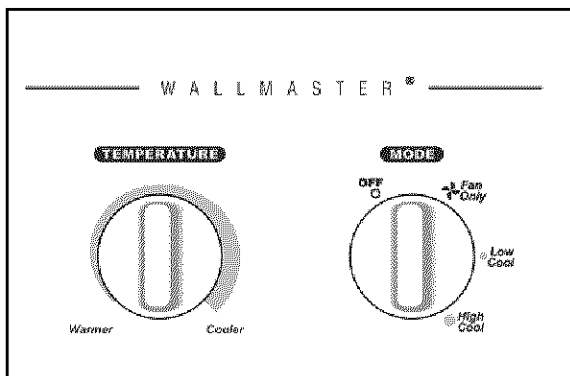

COOLING ONLY MODEL

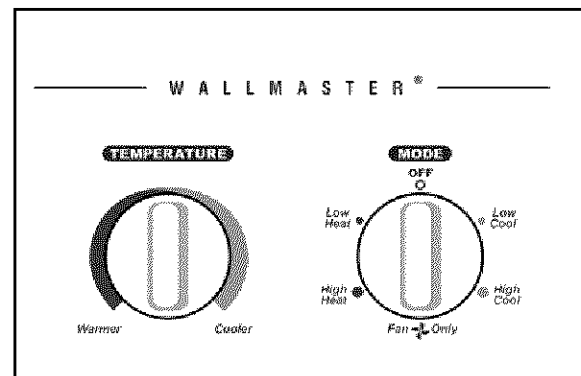

HEAT/COOL MODEL

D. Temperature Limiting Thermostat

1. Set the thermostat knob to center of dial.
2. Remove the four screws holding the control panel. Pull up on the thermostat knob and remove it.
3. Locate the two temperature limiting screws. These screws are factory installed for a maximum temperature range of 60°-90°F. Each hole in the dial plate represents approximately a 4° change from the adjacent hole.
4. To adjust the temperature range, move the temperature limiting screws to the desired location.
5. Replace the knob when the desired range has been set.
6. Replace the control panel.

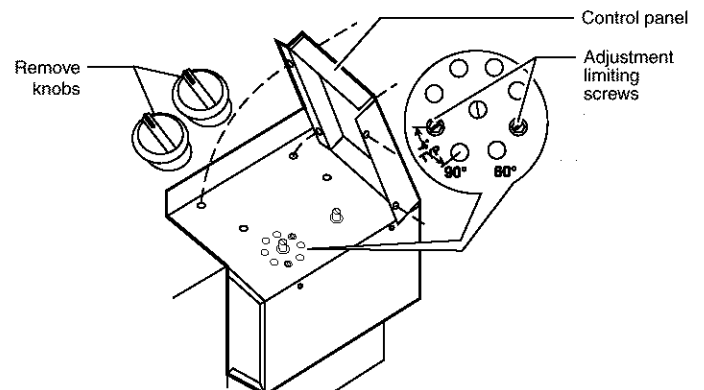

EXAMPLE: To set a maximum temperature range of approximately 64° to 86°F, move the screws to the locations shown in the diagram at right.

E. Heating Control (heat pumps and emergency heat operation)

NOTE: Heat pump models only. Heat pump equipped models use backup electric resistance heating coils. At extremely low, outdoor ambient temperatures, the heat pump is automatically disabled and the unit operates solely on electric resistance heat.

This control is located behind the decorative front cover and is found on the right side panel of the chassis. Its function is to allow you to set the temperature range in which the heat pump operates. This control switches the unit heat operation between heat pump and electric resistance heat based on the outdoor ambient temperature. These change-over temperatures are based on the settings of the control. The factory setting is at the one o'clock position. If you wish to change the factory set point, insert a flat-bladed screwdriver into the slot and turn counterclockwise to increase the changeover set point, or clockwise to decrease it.



NOTE: The factory set point is recommended for optimum performance.

NOTE: Emergency heat operation only. In the event of a compressor malfunction in the heat pump mode, turn the screw to the extreme counterclockwise emergency heat position. The heater will then cycle using electric resistance heat only. Note that in the emergency heat position, the compressor is locked out, disabling both heat pump and cooling operations. CALL A SERVICE PERSON. DO NOT FORGET TO RETURN THE CONTROL TO ITS ORIGINAL POSITION AFTER REPAIRS ARE MADE OR THE COMPRESSOR WILL NOT COME ON IN COOLING MODE.

F. Fan Cycle Switch

The fan cycle switch is located behind the decorative front cover below the control panel. It is designed to operate the fan either continuously or intermittently with the compressor or heating elements. When the switch is in the CONTINUOUS position, the fan will run continuously at the selected speed when the unit is turned on. With the fan cycle switch in the CYCLE position, the fan will run only when the compressor or heating elements cycle on.



NOTE: It is recommended that this switch be set in the continuous position for maximum comfort and temperature control.

G. Fresh Air Vent Control

The vent control lever is located behind the front cover on the left side of the unit. The unit is shipped in the closed position with a locking screw in place. The screw must be removed to operate the lever. When the lever is back, (OPEN), outside air is mixed with indoor air. When the lever is forward, (CLOSED), no outside air is admitted into the room and room air is recycled through the unit.

NOTE: The vent should remain closed for peak operating efficiency.

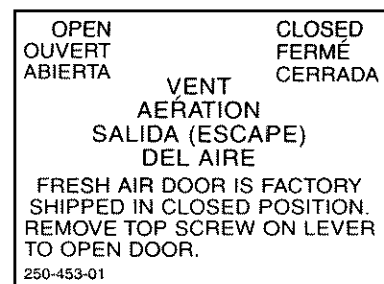

H. Air Discharge Grille



WARNING

Moving parts hazard.

Turn off electric power before servicing this component.

Failure to do so can result in property damage, personal injury and/or death.

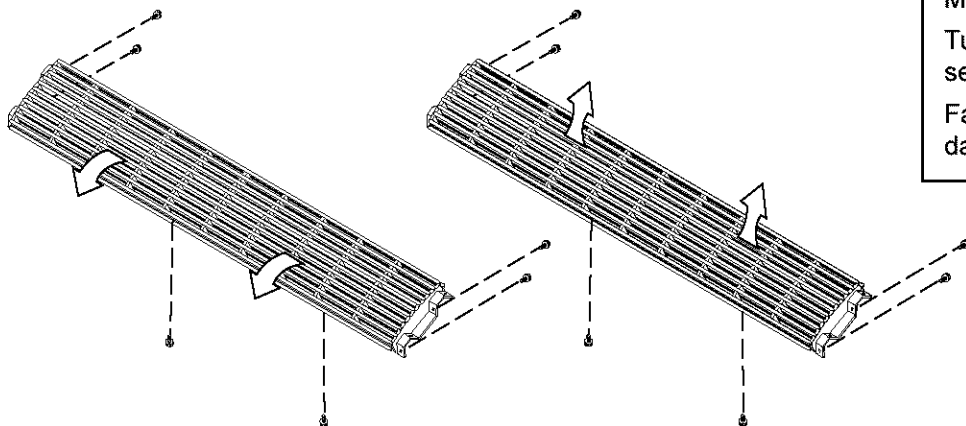

The air discharge grille can be redirected to blow air either straight up or at an angle into the room. To change the airflow direction, remove the front cover, locate and remove the six grill retaining screws. Reverse the ends of the grille and refasten the grille to the cover.

I. Start-up Checklist

- Inspect all components and accessories for damage before and after installation.
 - Check installation for compliance with all national and local codes and ordinances.
 - Read and follow all manufacturer's installation instructions.
 - Check that circuit breaker(s) and electrical wire sizes are correct. If the unit is supplied with a power supply cord, insure that it is stored properly.
 - Check the condensate water drain outlet(s) to make sure they are in compliance with all national and local codes, that they are adequate for the removal of condensate water, and that they meet the approval of the end user.
 - Strictly follow installation instructions concerning clearances around the unit.
 - Secure components and accessories, such as the control door and front cover.
 - Check the unit air filter, condenser coil and evaporator coil for any obstructions.
 - Check for proper operation of all components.
 - Instruct the owner or operator of the units operation, and the manufacturer's recommended routine maintenance schedule.
- NOTE: It is highly recommended that a maintenance schedule log book be prepared for recording the dates and times of service.**
- Operate the unit for twenty minutes. Record the unit's indoor/outdoor intake and discharge temperatures, amperage draw, and power voltage.
 - Assemble the Warranty Certificate, the Operation and Installation Manual, all accessory installation instructions and the name, address and telephone number of the Authorized Friedrich Warranty Service Company in the area for the owner or operator.

NOTE: Units are to be installed, inspected, and checked by qualified service personnel only.

Appendix A: Remote Thermostat Unit Installation

Remote Thermostat Selection & Wiring Guidelines for Packaged Terminal Air Conditioners

Follow the instructions and recommendations of the thermostat manufacturer for installation and wiring. Do not use a conventional heat pump thermostat with emergency electric heat selection for our heat pump units. Our units make an automatic decision about turning on electric heat if the heating demand cannot be met by the heat pump due to low outdoor temperatures.

NOTE: This unit is designed for use with a single stage thermostat only. Improper application of the thermostat may result in property damage, personal injury or death.

Manual Changeover Thermostat

For Heat Pump equipped units: A single stage, heat/cool thermostat with a terminal for a reversing valve operation is required. Terminal "B" should be continuously energized in the heat mode and terminal "G" should be energized whenever there is a call for heating or cooling. Typically, a heat/cool thermostat designed for use with electric heat systems will meet the above requirements.

Honeywell Thermostat Terminal Designation:

TERMINAL LETTER	OPERATION	CONTACT MADE
Y	Cooling	During call for cooling.
W	Heating	During call for heating.
G	Fan	Continuous if the slider is in the "Fan" position, otherwise, intermittent.
C	Common Terminal	For thermostats requiring a common terminal
R	24 V to the thermostat	Directly from the transformer
B (Heat Pump units Only)	Reversing Valve	Made continuously during call for heating.

For Non-Heat Pump equipped units: A single stage cooling and heating thermostat is required. Terminal "G" should be energized whenever a call for heating or cooling is made. Typically a heat/cool thermostat designed for use with electric heat systems will meet this requirement.

Simplified Wiring Example

Unit Terminal Board
 * A-Suffix models do not have a "C" terminal

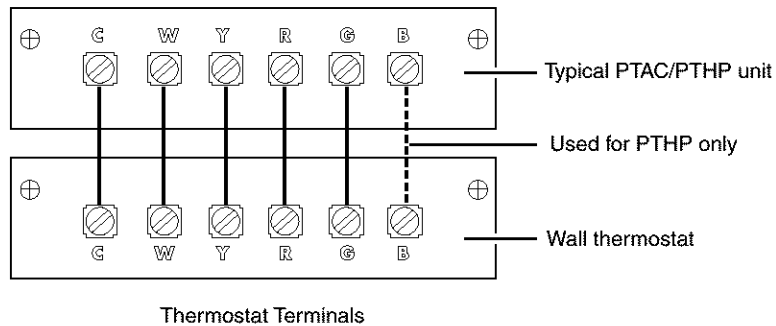

NOTE: It is the installer's responsibility to ensure that all control wiring connections are made in accordance with the installation instructions. Improper connection of the thermostat control wiring and/or tampering with the unit's internal wiring can void the equipment warranty and may result in property damage, personal injury or death. Other manufacturer's PTACs and even older Friedrich models may have different control wire connections. Questions concerning proper connections to the unit should be directed to the factory.

Appendix A (continued)

Remote Thermostat 208V Operation

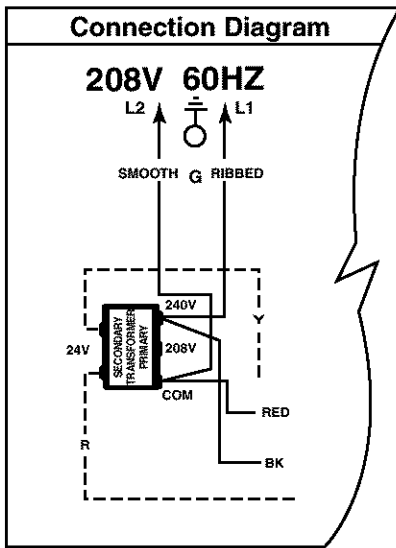

The simplified connection diagram at left shows the factory configured wiring set for 240V operation. If you are going to use 208V exclusively, switch the two (2) black wires on the 240V post of the primary side of the transformer to the 208V post. This will ensure correct secondary (low) voltages for the unit. This is only required on remote thermostat units.

CAUTION

CAUTION
If the supply voltage is 208V, the low voltage transformer **MUST** be wired for 208V operation. Failure to do so will result in lower control voltages to the unit and can damage low voltage components.

Remote Thermostat Unit Operation

These units are controlled by the use of a remote thermostat that will cycle the unit to maintain desired room temperature. See thermostat operating instruction sheet for details.

The fan speed switch controls high and low speed fan operation. It is located on the control panel and is independent of the thermostat.

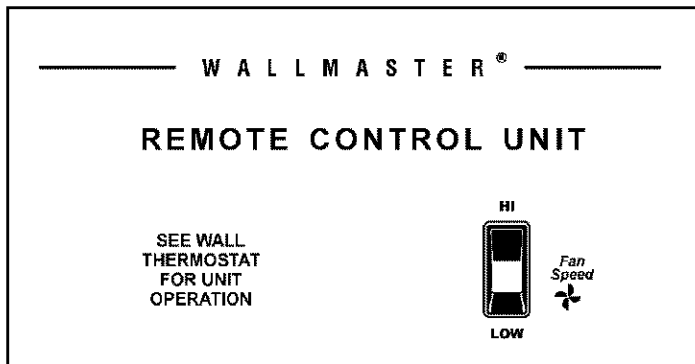

Auto Changeover Thermostat

A single stage heat/cool thermostat with auto changeover is needed. The wiring scheme is the same as the manual thermostat.

Remote Thermostat Installation

Follow Steps 1 through 5 (pages 12 and 13), then:

6. Locate the terminal strip on the front of the control box (See Figure 9). Attach the thermostat subbase wires (field supplied) to the appropriately labeled terminals in accordance with the wiring diagram on the side of the chassis.
7. Carefully route the wires alongside the conduit or service cord. Attach the other end of the wires to the appropriate terminals on the thermostat subbase. See the thermostat directions for proper wiring and mounting of the thermostat.

Figure 10
Terminal Strip Location

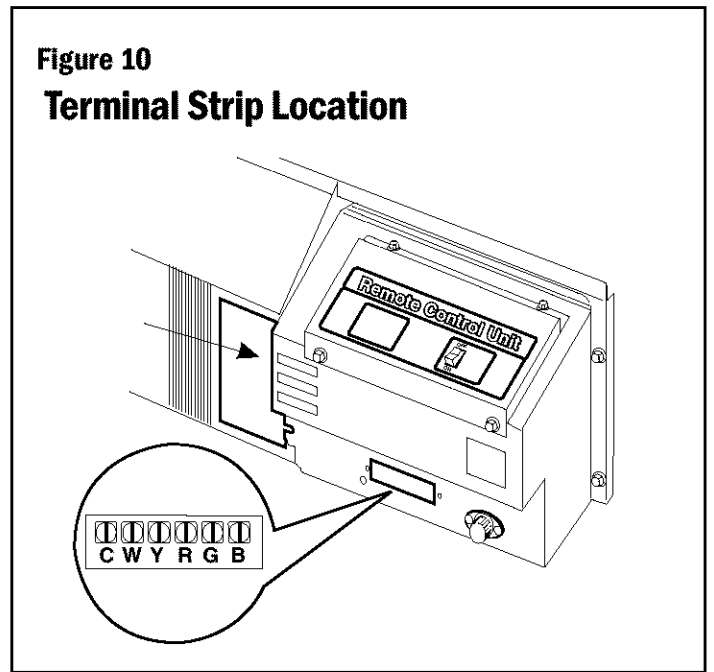

Appendix B: Electrical Wiring for 265 Volt Models

NOTE: It is recommended that the PXSB subbase assembly, the PXCJ conduit kit and the PXDS disconnect switch be installed on all hardwired units. If installing a flush-floor mounted unit, make provisions for all the line voltage power leads and conduit to be removed for ease of maintenance and service to the chassis.

To install the line voltage power leads and conduit to the chassis, follow the instructions below.

1. Remove the four control box retaining screws (A) and open the control box.
2. Pull the chassis power lead wires (B) (located on the bottom-right side of the control box) through the plastic bushing so they are located inside the control box.
3. Remove the plastic bushing.
4. Route the line voltage power leads through the hole where the plastic bushing was located, and secure its conduit (use a 1/2" straight conduit connector, with the locknut on the inside of the control box.)
5. Make the appropriate electrical connections within the control box, then secure the box on the chassis. Detailed instructions are included with the installation instructions for the conduit kit (PXCJ).
6. Route the line voltage power conduit from the control box straight down the right front to the bottom side of the chassis. This will allow the front cover to be installed without interference with the electrical conduit.

Figure 11

Line Voltage Connections

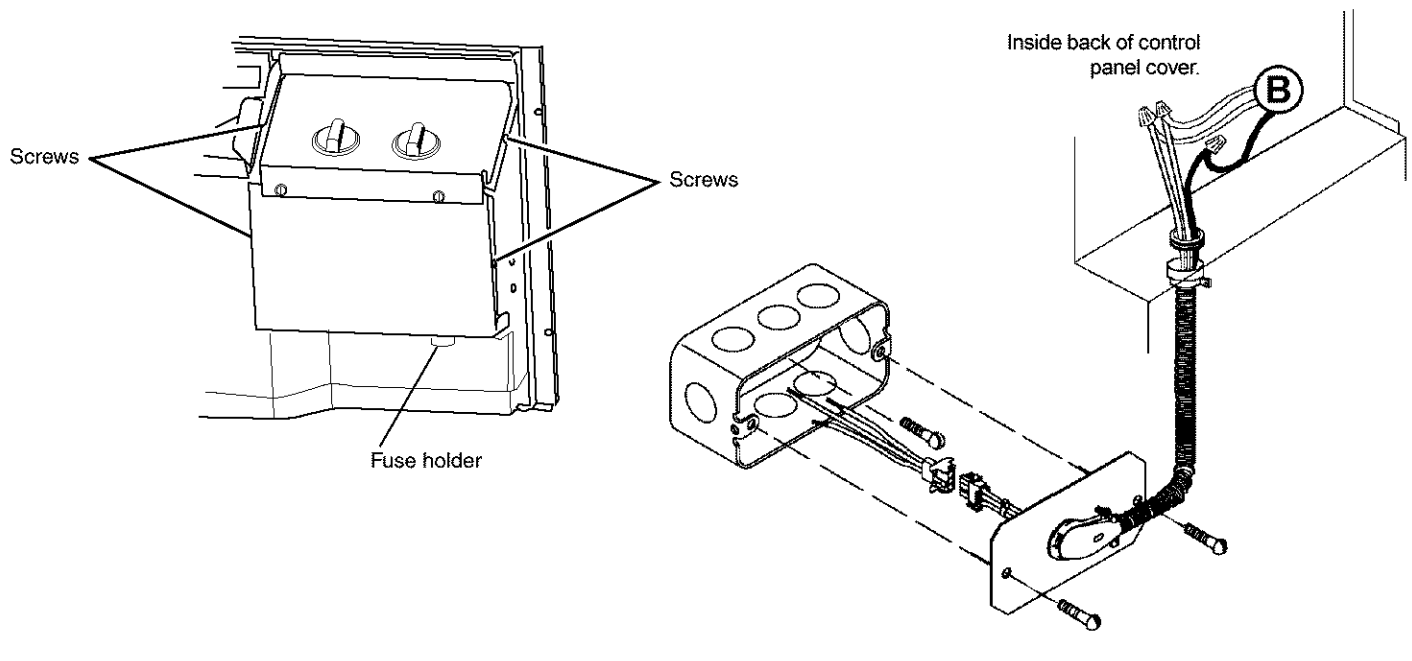

J. Routine Maintenance

NOTE: Units are to be inspected and serviced by qualified service personnel only.

1. Clean the unit air intake filter at least every 300 to 350 hours of operation. Clean the filters with a mild detergent in warm water and allow to dry thoroughly before reinstalling.
2. The indoor coil (evaporator coil), the outdoor coil (condenser coil) and base pan should be inspected periodically (yearly or bi-yearly) and cleaned of all debris (lint, dirt, leaves, paper, etc.). Clean the coils and base pan with a soft brush and

compressed air or vacuum. If using a pressure washer, be careful not to bend the aluminium fin pack. Use a sweeping up and down motion in the direction of the vertical aluminium fin pack when pressure cleaning coils. Cover all electrical components to protect them from water or spray. Allow the unit to dry thoroughly, inspect all gasket material for deterioration (replace as necessary), and then reinstall the chassis in the sleeve.

NOTE: Do not use a caustic coil cleaning agent on coils or base pan. Use a biodegradable cleaning agent and degreaser.

Before reinstalling the chassis in the sleeve, inspect the indoor blower housing, blower wheel, condenser fan blade, and condenser shroud periodically (yearly or bi-yearly) and clean of all debris (lint, dirt, mold, fungus, etc.) Clean the blower housing area and blower wheel with an antibacterial / antifungal cleaner. Use a biodegradable cleaning agent and degreaser on condenser fan and condenser shroud. Use warm or cold water when rinsing these items. Allow all items to dry thoroughly before reinstalling them.

3. Periodically (at least yearly or bi-yearly): inspect all control components, both electrical and mechanical, as well as the power supply. Use proper testing instruments (voltmeter, ohmmeter, ammeter, wattmeter, etc.) to perform electrical tests. Use an air conditioning or refrigeration thermometer to check room, outdoor and coil operating temperatures. Use a sling psychrometer to measure wet bulb temperatures indoors and outdoors.

4. Inspect the surrounding area (inside and outside) to ensure that the units' clearances have not been compromised or altered.
5. Inspect the sleeve and drain system periodically (at least yearly or bi-yearly) and clean of all obstructions and debris. Clean both areas with an antibacterial and antifungal cleaner. Rinse both items thoroughly with water and ensure that the drain outlets are operating correctly. Check the sealant around the sleeve and reseal areas as needed.
6. Clean the front cover when needed. Use a mild detergent. Wash and rinse with warm water. Allow them to dry thoroughly before reinstalling them in the chassis.

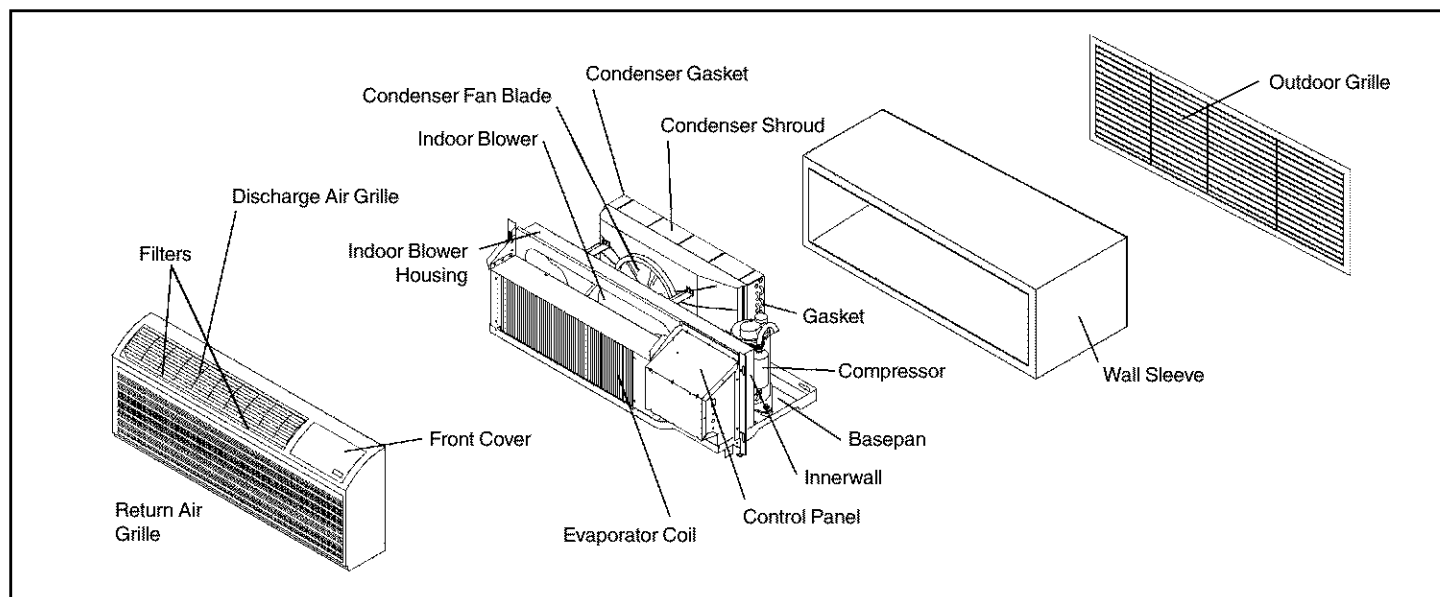

K. Basic Troubleshooting Techniques

Being familiar with the sequence of operation on Standard Controlled Operating Units or the operation of the Remote Thermostat Controlled Units is important. The following questions and answers may help to identify performance problems.

Environmental Effects - Cooling Mode

Is unit sized to room size area and heat load demand?

Room Width x Length x 3.5 (x-factor) equal a "guesstimate" of the number of BTU's required for the area. The number of people in the room, number of electrical devices, solar gains, etc. are all variable items that can affect proper sizing of the unit. Friedrich recommends that you consult with an applications engineer for proper sizing.

Is the outdoor temperature 60°F or below?

The unit is designed for outdoor temperatures above 60°F.

Is the indoor temperature 80°F or above?

Ambient indoor temperatures of 80°F or above will take a longer period of run time to cool down the area. Long run times may indicate that the unit is undersized.

Is indoor humidity high?

This condition will cause the unit to operate longer to remove humidity before noticing any cooling effect.

Has the heat load been increased by additional devices such as computer equipment, or has the room area been increased where the unit is located?

If conditions have changed, the unit may not be able to cool and condition as effectively as previously planned.

Environmental Effects - Heating Mode

Is unit properly sized to room area and heat load demand?

Multiplying the Width x Length x 3.5 ("x-factor") provides a "guesstimate" of the number of BTU's required for the area. The number of people in the room, number of electrical devices, solar gains, etc. are all variable items that can affect proper sizing of the unit. Friedrich recommends that you consult with an applications engineer for proper sizing.

Is the outdoor temperature 70°F or above? - The unit is designed for outdoor temperatures below 70°F.

Is the indoor temperature 60°F or below? Ambient indoor temperatures of 60°F or below will take a longer period of run time to heat the area. Long run times may indicate that the unit is undersized.

Has the room area been increased where the unit is located?

If the area where the unit is located has been increased, the unit may not provide adequate heat.

Insufficient Maintenance and Inspection

Installation errors are the most common cause of poor performance. Please follow installation instructions carefully. If other problems exist, see Maintenance and Inspection Troubleshooting Guide below.

Maintenance and Inspection Troubleshooting Guide

CAUSE	RESULT
System is not serviced or inspected regularly (semiannually or annually).	Can result in premature component failures, poor performance and increased operating costs.
Air filters are not cleaned regularly and become blocked with particles.	May result in poor cooling, icing and water problems as well as component failures and increased operating costs.
Condenser coil not maintained properly (blocked with particles).	May result in poor cooling, component failures and increased costs.
Evaporator coil not maintained properly (blocked with particles).	May result in poor cooling, icing and water problems, and increased operating costs.
Components that show signs of fatigue - not replaced.	May result in multiple service calls, poor performance and increased operating costs.
Condensate drains and drain lines not maintained.	May result in water and odor problems.

Friedrich PTAC Accessories

NEW CONSTRUCTION ACCESSORIES

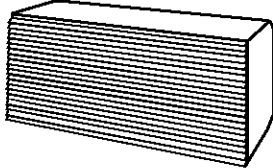
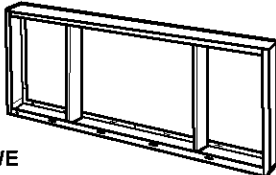
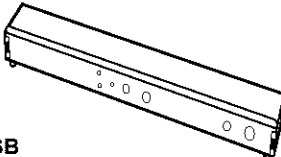
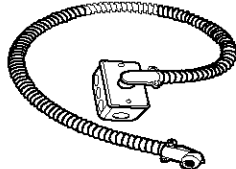
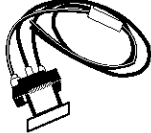
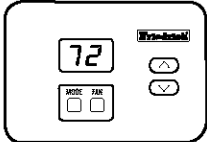
MODEL NUMBER	DESCRIPTION	PHOTO
PXWS	WALL SLEEVE G-90 zinc coated steel is prepared in an eleven-step process, then electrostatically coated with a polyester finish and cured in an oven for exceptional durability. The wall sleeve is insulated for thermal efficiency. 16" High x 42" Wide x 13¼" Deep.	 PXWS
PXGA	GRILLE, standard, stamped aluminium, anodized to resist chalking and oxidation.	 PXDB
PXAA PXDB PXSC	ARCHITECTURAL GRILLS that consist of heavy-gauge 6063-T5 aluminium alloy: Clear, extruded aluminium or dark bronze acrylic enamel <i>Also available in custom colors.</i>	
PXDR10	CONDENSATE DRAIN KIT Attaches to the bottom of the wall sleeve for internal draining of condensate or to the rear wall sleeve flange for external draining. Recommended on all units to remove excess condensate. Packaged in quantities of ten.	
PXWE	DEEP WALL SLEEVE EXTENSION A four inch deep anodized aluminium extension that attaches to the outside of the wall sleeve when the wall is greater than eleven inches thick (9½" when a subbase is used, 10 inches when a lateral duct is used).	 PXWE
PXSB	DECORATIVE SUBBASE Provides unit support for walls less than six inches thick. Includes leveling legs, side filler panels and mounting brackets for electrical accessories. Accepts circuit breaker, power disconnect switch, or conduit kit.	 PXSB
PXCJ	CONDUIT KIT WITH JUNCTION BOX Hard wire conduit kit with junction box for 208/230V and 256V units (subbase not required). Kit includes a means of quick disconnect for easy removal of the chassis. *Required for 265V installations.	 PXCJ
PXDC	DESK CONTROL KIT A field installed kit which allows the unit to be turned on or off from a remote central station via a 24V interface.	 PXDC
RT2	DIGITAL REMOTE THERMOSTAT A Honeywell wall mounted remote thermostat. Requires proper P-Series chassis.	 RT2

Friedrich PTAC Accessories (continued)

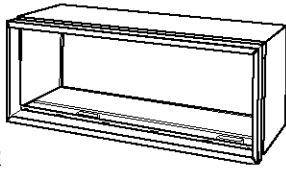
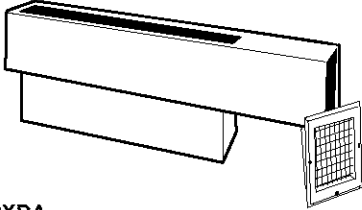
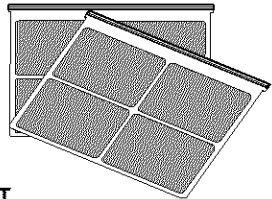
ADDITIONAL ACCESSORIES		
MODEL NUMBER	DESCRIPTION	PHOTO
PXSE	SLEEVE EXTENSION RETROFIT KIT G-90 zinc coated steel, 2.4" sleeve extension attached to the room side of the sleeve to allow for the installation of a P-Series Friedrich PTAC in a T-Series sleeve.	 PXSE
PXDA	LATERAL DUCT ADAPTER Attaches to the PTAC/PTHP unit and provides a transition to direct up to 35% of the total CFM to a secondary room, either left or right of the unit. Kit includes duct plenum with discharge grille and internal baffle, adapter and end cap.	 PXDA
PXDE	LATERAL DUCT EXTENSION A three foot insulated plenum that attaches to the left or right side of the duct adapter. The extension can be cut to length by the installer. Maximum allowable straight extension is fifteen feet.	
PXFT	REPLACEMENT FILTER PACK These are original equipment return air filters. They are reusable and can be cleaned by vacuuming, washing, or blowing out, and are sold in convenient ten packs. (Two filters per chassis)	 PXFT
CHASSIS OPTIONS		
DESIGNATOR	DESCRIPTION	
S	STANDARD UNIT Standard PTAC/PTHP chassis. Can be 230/208V or 265V, electric or heat pump.	
R	REMOTE THERMOSTAT Chassis option necessary for wall mounted thermostat control of the unit.	
C	SEACOAST PROTECTION Additional protection for PTAC/PTHP units in a coastal or corrosive environment. The entire outdoor coil is submerged in a specially formulated enamel coating, then oven-cured for a tough, corrosion-resistant finish.	

FRIEDRICH WALLMASTER® P-SERIES PACKAGED TERMINAL AIR CONDITIONERS LIMITED WARRANTY



FRIEDRICH AIR CONDITIONING CO.
Post Office Box 1540 · San Antonio, Texas 78295-1540
(210) 357-4400 · FAX (210) 357-4480

SAVE THIS CERTIFICATE. It gives you specific rights, you may also have other rights which may vary from state to state and province to province.

In the event that your unit needs servicing, contact your nearest authorized service center. If you do not know the nearest service center, ask the company that installed your unit or contact us - see address and telephone number below.

When requesting service: please have the model and serial number from your unit readily available.

Unless specified otherwise herein, the following applies:

PACKAGED TERMINAL AIR CONDITIONERS AND HEAT PUMPS

LIMITED WARRANTY - FIRST YEAR (Eighteen (18) Months from the original date of purchase or twelve (12) months from installation). Any defect in the unit's material or workmanship will be repaired or replaced free of charge by our authorized service center during the normal working hours; and

LIMITED WARRANTY - SECOND THROUGH FIFTH YEAR (Sixty-six (66) months from the date of purchase) ON THE SEALED REFRIGERATION SYSTEM. Any part of the sealed refrigeration system on the P-series that is defective in material or workmanship will be repaired or replaced free of charge (excluding freight charges) by our authorized service center during normal working hours. The sealed refrigeration system consists of the compressor, metering device, evaporator, condenser, reversing valve, check valve, and the interconnecting tubing.

These warranties apply only while the unit remains at the original site and only to units installed inside the continental United States, Alaska, Hawaii, Puerto Rico and Canada. The warranty applies only if the unit is installed and operated in accordance with the printed instructions and in compliance with applicable local installation and building codes and good trade practices.

For international warranty information, contact the Friedrich Air Conditioning Company - International Division.

Reasonable proof must be presented to establish the original purchase date, otherwise the beginning date of this certificate will be considered to be our shipment date plus sixty days. Replacement parts can be new or remanufactured. Replacement parts and labor are only warranted for any unused portion of the unit's warranty.

We will not be responsible for and the user will pay for:

1. Service calls to:

A) Instruct on unit operation. B) Replace house fuses or correct house wiring. C) Clean or replace air filters. D) Remove the unit from inaccessible locations. E) Correct improper installations.

2. Parts or labor provided by anyone other than an authorized service center.

3. Damage caused by:

A) Accident, abuse, negligence, misuse, riot, fire, flood, or acts of God. B) Operating the unit where there is a corrosive atmosphere containing chlorine, fluorine, or any damaging chemicals (other than in a normal residential environment). C) Unauthorized alteration or repair of the unit, which in turn affects its stability or performance. D) Failing to provide proper maintenance and service. E) Using other than a "Seacoast Protected" unit in a coastal environment. F) Using an incorrect power source. G) Faulty installation or application of the unit.

We shall not be liable for any incidental, consequential, or special damages or expenses in connection with any use or failure of this unit. We have not made and do not make any representation or warranty of fitness for a particular use or purpose and there is no implied condition of fitness for a particular use or purpose. We make no expressed warranties except as stated in this certificate. No one is authorized to change this certificate or to create for us any other obligation or liability in connection with this unit. Any implied warranties shall last for one year after the original purchase date. Some states and provinces do not allow limitations on how long an implied warranty or condition lasts, so the above limitations or exclusions may not apply to you. The provisions of this warranty are in addition to and not a modification of or subtraction from the statutory warranties and other rights and remedies provided by law.

In case of any questions regarding the provisions of this warranty, the English version will govern.

Revised 8/01

Model No. _____	Serial No. _____
Date Purchased: _____	Installation Location: _____
Date Installed: _____	Installed by: _____