

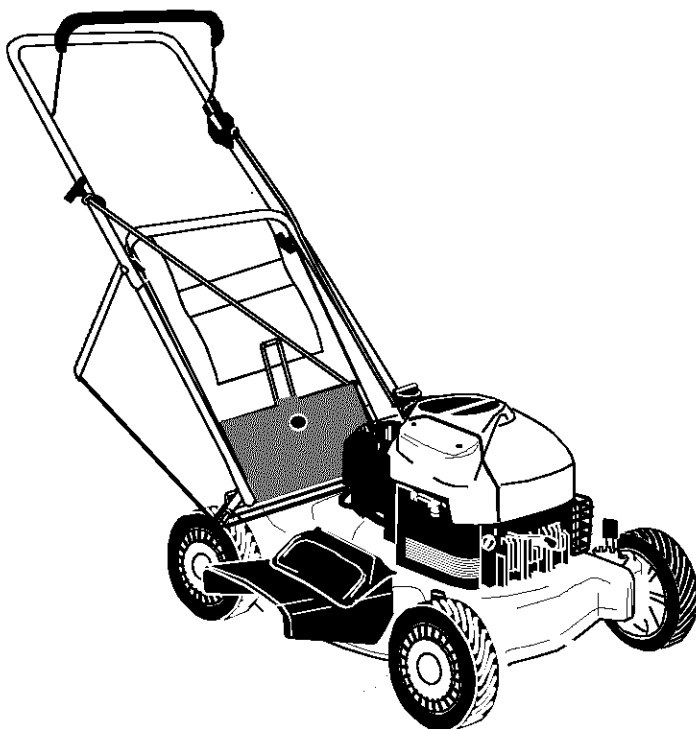

# Operator's Manual



## 21" Rear & Side Discharge Mulching Lawn Mower

Model 436

**IMPORTANT:** Read safety rules and instructions carefully before operating equipment.

**Warning:** This unit is equipped with an internal combustion engine and should not be used on or near any unimproved forest-covered, brush-covered or grass-covered land unless the engine's exhaust system is equipped with a spark arrester meeting applicable local or state laws (if any). If a spark arrester is used, it should be maintained in effective working order by the operator. In the State of California the above is required by law (Section 4442 of the California Public Resources Code). Other states may have similar laws. Federal laws apply on federal lands. A spark arrester for the muffler is available through your nearest engine authorized service dealer or contact the service department, P.O. Box 361131 Cleveland, Ohio 44136-0019.

**TROY-BILT LLC. P.O. BOX 361131 CLEVELAND, OHIO 44136-0019**

# TABLE OF CONTENTS

Content	Page
Important Safe Operation Practices .....	3
Slope Gauge .....	6
Assembling Your Lawn Mower .....	7
Know Your Lawn Mower .....	10
Operating Your Lawn Mower .....	11
Maintaining Your Lawn Mower .....	12
Service .....	13
Making Adjustments .....	14
Off- Season Storage .....	15
Troubleshooting .....	15
Parts List .....	16

## FINDING MODEL NUMBER

This Operator's Manual is an important part of your new Lawn Mower. It will help you assemble, prepare and maintain the unit for best performance. Please read and understand what it says.



**Before you start assembling your new equipment**, please locate the model plate on the equipment and copy the information from it in the space provided below. The information on the model plate is very important if you need help from our Customer Support Department or an authorized dealer.

- You can locate the model number by standing behind the unit in the operating position and looking down at the rear of the deck. A sample model plate is explained below. For future reference, please copy the model number and the serial number of the equipment in the space below.

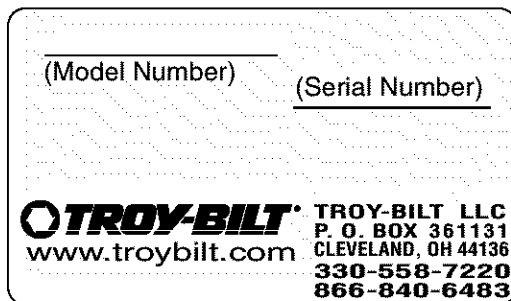

Copy the model number here: \_\_\_\_\_

Copy the serial number here: \_\_\_\_\_

## ENGINE INFORMATION

The engine manufacturer is responsible for all engine-related issues with regards to performance, power-rating, specifications, warranty and service. Please refer to the engine manufacturer's Owner's/Operator's Manual packed separately with your unit for more information.

## CALLING CUSTOMER SUPPORT

If you have difficulty assembling this product or have any questions regarding the controls, operation or maintenance of this unit, please call **1-866-840-6483** or **1-330-558-7220** to reach a Customer Support representative. Please have your unit's model number and serial number ready when you call. See previous section to locate this information. You will be asked to enter the serial number in order to process your call.

For more details about your unit, visit our website at [www.troybilt.com](http://www.troybilt.com)

---

## SECTION 1: IMPORTANT SAFE OPERATION PRACTICES



**WARNING:** This symbol points out important safety instructions which, if not followed, could endanger the personal safety and/or property of yourself and others. Read and follow all instructions in this manual before attempting to operate this machine. Failure to comply with these instructions may result in personal injury. When you see this symbol—HEED ITS WARNING



**WARNING:** This machine was built to be operated according to the rules for safe operation in this manual. As with any type of power equipment, carelessness or error on the part of the operator can result in serious injury. This machine is capable of amputating hands and feet and throwing objects. Failure to observe the following safety instructions could result in serious injury or death.



**WARNING:** Engine exhaust, some of its constituents, and certain vehicle components contain or emit chemicals known to State of California to cause cancer and birth defects or other reproductive harm.

### General Operation

1. Read this operator's manual carefully in its entirety before attempting to assemble this machine. Read, understand, and follow all instructions on the machine and in the manual(s) before operation. Be completely familiar with the controls and the proper use of this machine before operating it. Keep this manual in a safe place for future and regular reference and for ordering replacement parts.
2. This machine is a precision piece of power equipment, not a plaything. Therefore, exercise extreme caution at all times. Your unit has been designed to perform one job: to mow grass. Do not use it for any other purpose.
3. Never allow children under 14 years old to operate this machine. Children 14 years old and over should read and understand the operation instructions and safety rules in this manual and should be trained and supervised by a parent. Only responsible individuals who are familiar with these safe operation rules should use this machine.
4. Thoroughly inspect the area where the equipment is to be used. Remove all stones, sticks, wire, bones, toys and other foreign objects which could be tripped over or picked up and thrown by the blade. Thrown objects can cause serious personal injury. Plan your mowing pattern to avoid discharge of material toward roads, sidewalks, bystanders and the like. Also, avoid discharging material against a wall or obstruction which may cause discharged material to ricochet toward operator.
5. To help avoid blade contact or a thrown object injury, stay in the operator zone behind the handles and keep bystanders, helpers, children and pets at least 75 feet from the machine while it is in operation. Stop machine if anyone enters the area.
6. Always wear safety glasses or safety goggles during operation and while performing an adjustment or repair to protect your eyes. Thrown objects which ricochet can cause serious injury to the eyes.
7. Wear sturdy, rough-soled work shoes and close-fitting slacks and shirts. Shirts and pants that cover the arms and legs and steel-toed shoes are recommended. Never operate this machine in bare feet, sandals, slippery or light weight (e.g. canvas) shoes.
8. Do not put hands or feet near rotating parts or under the cutting deck. Contact with the blade can amputate hands and feet.
9. A missing or damaged discharge cover can cause blade contact or thrown object injuries.
10. Many injuries occur as a result of the mower being pulled over the foot during a fall caused by slipping or tripping. Do not hold on to the mower if you are falling; release the handle immediately.
11. Never pull the mower back toward you while you are walking. If you must back the mower away from a wall or obstruction first look down and behind to avoid tripping and then follow these steps:
  - a. Step back from the mower to fully extend your arms.
  - b. Be sure you are well balanced with sure footing.
  - c. Pull the mower back slowly, no more than half way toward you.
  - d. Repeat these steps as needed.
5. Do not operate the mower while under the influence of alcohol or drugs.
6. Do not engage the self-propelled mechanism on units so equipped while starting engine.
7. The blade control handle is a safety device. Never attempt to bypass its operation. Doing so makes the safety device inoperative and may result in personal injury through contact with the rotating blade. The blade control handle must operate easily in both directions and automatically return to the disengaged position when released.

8. Never operate the mower in wet grass. Always be sure of your footing. A slip and fall can cause serious personal injury. If you feel you are losing your footing, release the blade control handle immediately and the blade will stop rotating within three seconds.
9. Mow in daylight or good artificial light. Walk, never run. Stop the blade when crossing gravel drives, walkways or roads.
10. If the equipment should start to vibrate abnormally, stop the engine and check immediately for the cause. Vibration is generally a warning of trouble.
11. Shut the engine off and wait until the blade comes to a complete stop before removing the grass catcher or unclogging the chute. The cutting blade continues to rotate for a few seconds after the engine is shut off. Never place any part of the body in the blade area until you are sure the blade has stopped rotating.
12. Never operate mower without proper trail shield, discharge cover, grass catcher, blade control handle or other safety protective devices in place and working. Never operate mower with damaged safety devices. Failure to do so, can result in personal injury.
13. Muffler and engine become hot and can cause a burn. Do not touch.
14. Only use parts and accessories made for this machine by the original equipment manufacturer (O.E.M). Failure to do so can cause personal injury.
15. If situations occur which are not covered in this manual, use care and good judgment. Contact your dealer for assistance. Telephone 1-866-840-6483 for the name of your nearest dealer.

## Slope Operation

Slopes are a major factor related to slip and fall accidents which can result in severe injury. Operation on slopes requires extra caution. If you feel uneasy on a slope, do not mow it. Before operating this unit on a slope or hilly area, use the slope gauge on page 6 to measure slopes. If the slope is greater than 15 degrees, do not mow it.

### Do:

1. Mow across the face of slopes; never up and down. Exercise extreme caution when changing direction on slopes.
2. Watch for holes, ruts, rocks, hidden objects, or bumps which can cause you to slip or trip. Tall grass can hide obstacles.
3. Always be sure of your footing. A slip and fall can cause serious personal injury. If you feel you are losing your balance, release the blade control handle immediately, and the blade will stop rotating within 3 seconds.

### Do Not:

1. Do not mow near drop-offs, ditches or embankments, you could lose your footing or balance.
2. Do not mow slopes greater than 15 degrees as shown on the slope gauge.
3. Do not mow on wet grass. Unstable footing could cause slipping.

## Children

Tragic accidents can occur if the operator is not alert to the presence of children. Children are often attracted to the mower and the mowing activity. They do not understand the dangers. Never assume that children will remain where you last saw them.

1. Keep children out of the mowing area and under the watchful care of a responsible adult other than the operator.
2. Be alert and turn mower off if a child enters the area.
3. Before and while moving backwards, look behind and down for small children.
4. Use extreme care when approaching blind corners, doorways, shrubs, trees, or other objects that may obscure your vision of a child who may run into the mower.
5. Keep children away from hot or running engines. They can suffer burns from a hot muffler.
6. Never allow children under 14 years old to operate a power mower. Children 14 years old and over should read and understand the operation instructions and safety rules in this manual and should be trained and supervised by a parent.

## Service

### Safe Handling of Gasoline

1. To avoid personal injury or property damage use extreme care in handling gasoline. Gasoline is extremely flammable and the vapors are explosive. Serious personal injury can occur when gasoline is spilled on yourself or your clothes which can ignite.
2. Wash your skin and change clothes immediately.
3. Use only an approved gasoline container.
4. Never fill containers inside a vehicle or on a truck or trailer bed with a plastic liner. Always place containers on the ground away from your vehicle before filling.
5. If possible, remove gas-powered equipment from the truck or trailer and refuel it on the ground. If this is not possible, then refuel such equipment on a trailer with a portable container, rather than from a gasoline dispenser nozzle.
6. Keep the nozzle in contact with the rim of the fuel tank or container opening at all times until fueling is complete. Do not use a nozzle lock-open device.

7. Extinguish all cigarettes, cigars, pipes and other sources of ignition.
8. Never fuel machine indoors because flammable vapors will accumulate in the area.
9. Never remove gas cap or add fuel while the engine is hot or running. Allow engine to cool at least two minutes before refueling.
10. Never over fill fuel tank. Fill tank to no more than ½ inch below bottom of filler neck to provide space for fuel expansion.
11. Replace gasoline cap and tighten securely.
12. If gasoline is spilled, wipe it off the engine and equipment. Move unit to another area. Wait 5 minutes before starting the engine.
13. Never store the machine or fuel container inside where there is an open flame, spark or pilot light as on a water heater, space heater, furnace, clothes dryer or other gas appliances.
14. To reduce fire hazard, keep mower free of grass, leaves, or other debris build-up. Clean up oil or fuel spillage and remove any fuel soaked debris.
15. Allow a mower to cool at least 5 minutes before storing.

### General Service

1. Never run an engine indoors or in a poorly ventilated area. Engine exhaust contains carbon monoxide, an odorless and deadly gas.
2. Before cleaning, repairing, or inspecting, make certain the blade and all moving parts have stopped. Disconnect the spark plug wire and ground against the engine to prevent unintended starting.
3. Check the blade and engine mounting bolts at frequent intervals for proper tightness. Also, visually inspect blade for damage (e.g., bent, cracked, worn) Replace blade with the original equipment manufacturer's (O.E.M.) blade only, listed in this manual. "Use of parts which do not meet the original equipment specifications may

lead to improper performance and compromise safety!"

4. Mower blades are sharp and can cut. Wrap the blade or wear gloves, and use extra caution when servicing them.
5. Keep all nuts, bolts, and screws tight to be sure the equipment is in safe working condition.
6. Never tamper with safety devices. Check their proper operation regularly.
7. After striking a foreign object, stop the engine, disconnect the spark plug wire and ground against the engine. Thoroughly inspect the mower for any damage. Repair the damage before starting and operating the mower.
8. Never attempt to make a wheel or cutting height adjustment while the engine is running.
9. Grass catcher components, discharge cover, and trail shield are subject to wear and damage which could expose moving parts or allow objects to be thrown. For safety protection, frequently check components and replace immediately with original equipment manufacturer's (O.E.M.) parts only, listed in this manual. "Use of parts which do not meet the original equipment specifications may lead to improper performance and compromise safety!"
10. Do not change the engine governor setting or overspeed the engine. The governor controls the maximum safe operating speed of the engine.
11. Maintain or replace safety and instruction labels, as necessary.
12. Observe proper disposal laws and regulations. Improper disposal of fluids and materials can harm the environment.

### Your Responsibility

- Restrict the use of this power machine to persons who read, understand and follow the warnings and instructions in this manual and on the machine.



USE THIS PAGE AS A GUIDE TO DETERMINE SLOPES WHERE YOU MAY NOT OPERATE SAFELY.

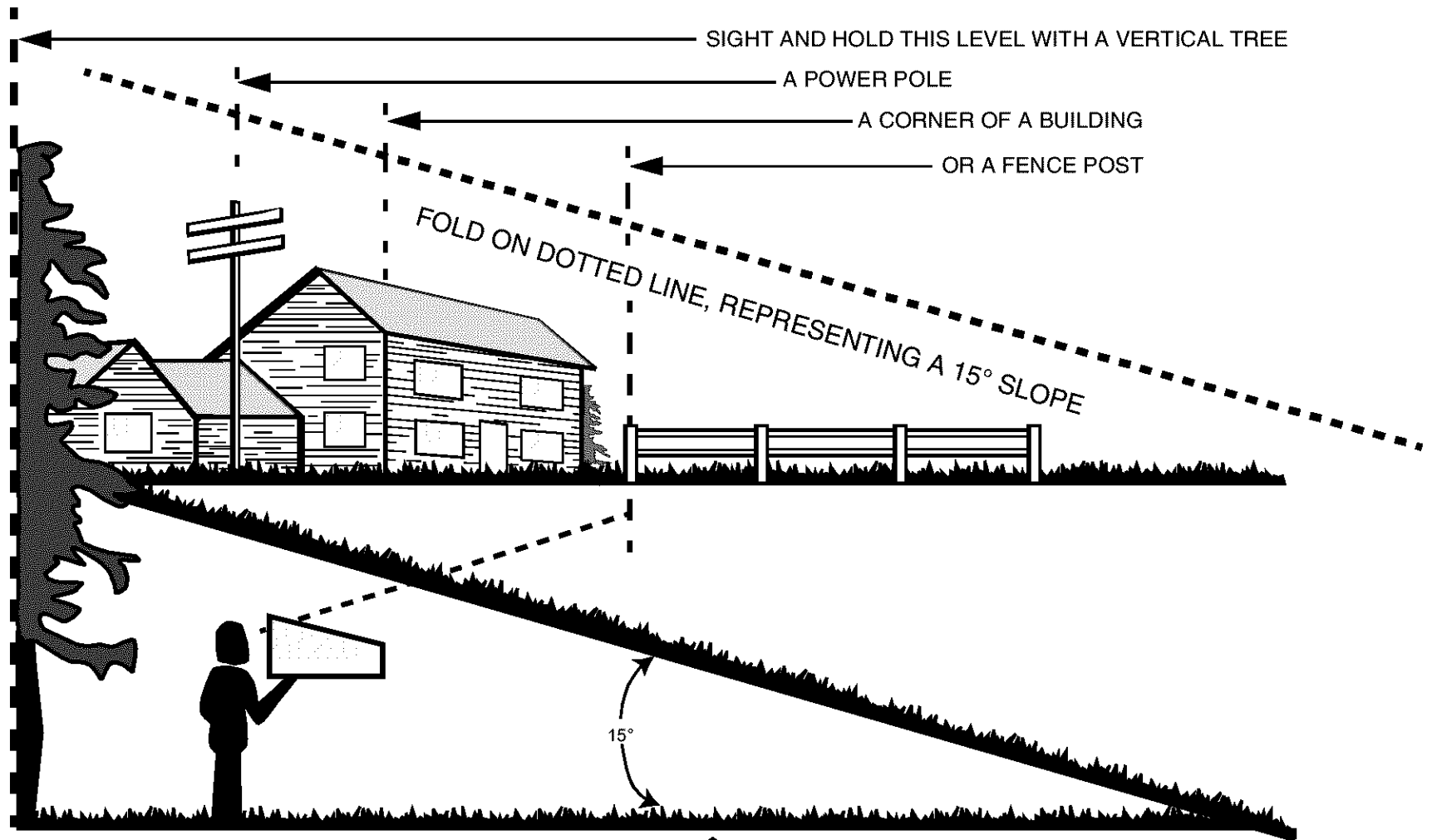

6

**SECTION 2: SLOPE GAUGE**

 **WARNING**

Do not mow on inclines with a slope in excess of 15 degrees (a rise of approximately 2-1/2 feet every 10 feet). A riding mower could overturn and cause serious injury. If operating a walk-behind mower on such a slope, it is extremely difficult to maintain your footing and you could slip, resulting in serious injury.

Operate RIDING mowers up and down slopes, never across the face of slopes.

Operate WALK-BEHIND mowers across the face of slopes, never up and down slopes.

## SECTION 3: ASSEMBLING YOUR LAWN MOWER

### Removing Unit From Carton

- Remove staples, break glue on top flaps or cut tape at carton end and peel top flap to open carton.
- Remove loose parts if included with unit.
- Cut corners and lay carton down flat. Remove packing material.
- Roll or slide unit out of carton. Check carton thoroughly for loose parts.

**NOTE:** Make sure not to crimp cables while removing the loose parts or the entire unit from the carton.

### Tools Required

- Pair of Pliers
- Funnel
- Set of adjustable wrenches

**NOTE:** Reference to right or left hand side of the mower is observed from the operating position.

### Disconnecting Spark Plug

- Before setting up your lawn mower, disconnect the spark plug wire from the spark plug, and ground it to a bolt, retaining post or V-slot on the engine. See Figure 1.

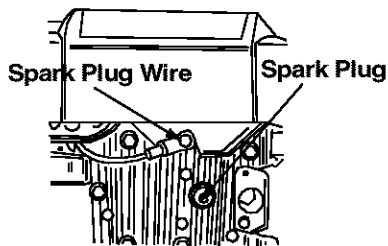

All Engines with Rubber Boot

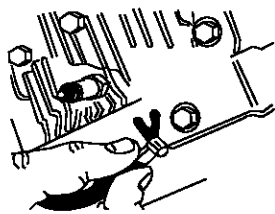

Briggs & Stratton Engines

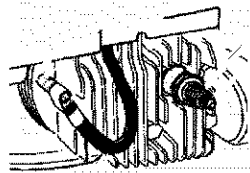

Tecumseh Engines

Figure 1

### Assembling Handle

- For shipping purposes, the grass bag was placed on top of the unit. Remove it from the unit and set it out of the way. See Figure 2 .

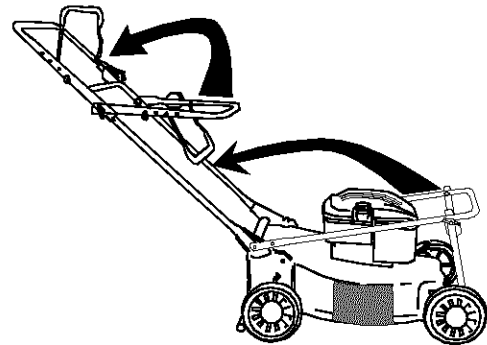

Figure 2

- Raise the lower handle, as shown in Figure 2 , till it snaps into place.
- Raise the upper handle as shown in Figure 2 .
- Tighten the two wing nuts which are already on the handle. See Figure 3 .

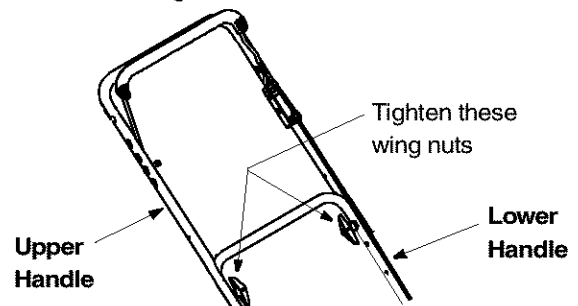

Figure 3

**NOTE:** Make sure to route the cables outside the lower handle. Also do not crimp the cables while lifting the handle up.

- For shipping purposes, the hairpin clip is placed in the outer hole of the weld pin on the lower handle. Remove the hairpin clip from the outer hole of the weld pin.
- Using a pair of pliers, insert the hairpin clip into the inner hole in the weld pin. Repeat on the other side. See Figure 4 .

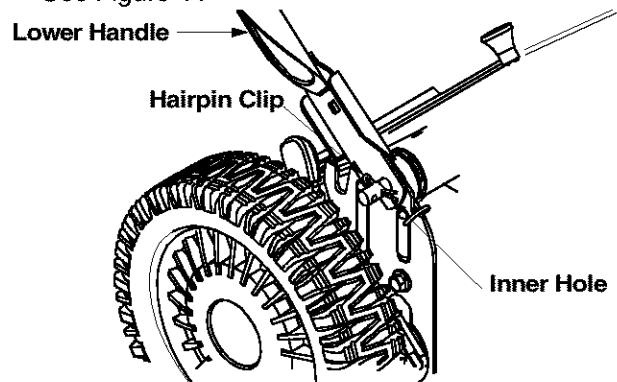

Figure 4

- Insert post of cable ties that are on lower handle into the holes provided on the lower handle. The holes may be on the inside or outside. Pull cable ties tight and cut off the extra. See Figure 5 below.

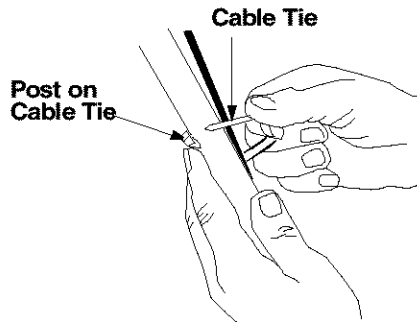

Figure 5

## Attaching Starter Rope

The rope guide is already attached to the right side of the lower handle of your mower. See Figure 6 .

- With the spark plug wire disconnected and grounded, hold the blade control handle against the upper handle, and pull the starter rope up to the rope guide. See Figure 6.
- Slip the rope through the rope guide as shown below. Tighten the wing nut holding the rope guide to the lower handle.

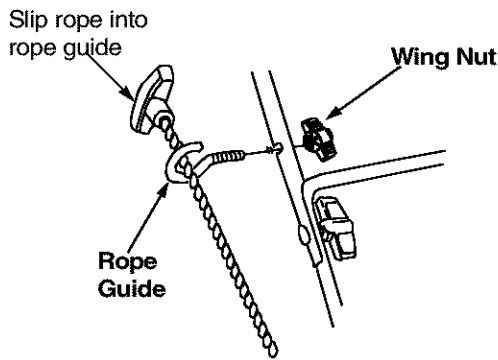

Figure 6

## Grass Catcher Assembly

**NOTE:** Make certain the grass bag is turned right side out before assembling (warning label will be on the outside).

### Parts for Soft Grass Bag

1. Front Frame
2. Rear Frame
3. Bag

### Assembling Soft Grass Bag

- Join the rear frame and front frame assembly as shown in Figure 7 A.

- Place the bag over the frame (black plastic side is the bottom of bag). Slip the openings in the side of the plastic channels on the bag over the hooks on the grass catcher frame.
- Secure bag to frame by working the plastic channels on bag over frame as shown in Figure 7 B. All of the plastic channels except the center top of the bag attach from the outside of bag. The center top of the bag attaches from inside the bag.

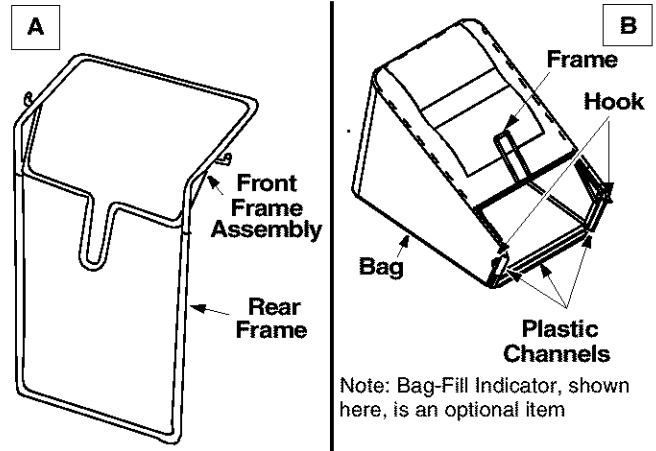

Figure 7

## Attaching Grass Catcher

- If your mower is equipped with a mulching plug, and it is in place on the mower, lift the rear discharge door and remove the rear mulching plug from the mower. See Figure 8 .

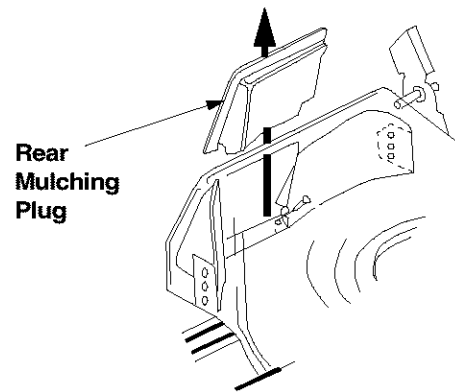

Figure 8

**NOTE:** Make sure that the cables are routed to the outside of the handle when attaching the grass catcher.

- Lift the rear discharge door.
- Place the hooks of the grass catcher into the slots in the handle bracket assemblies on both sides. See Figure 9 . Release the rear discharge door.



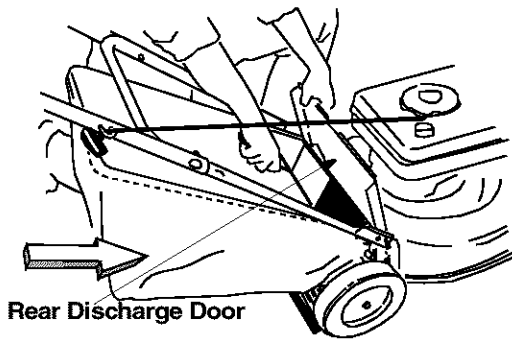

Figure 9



**WARNING:** Never operate the mower unless the hooks on the grass catcher are seated in the slots on the handle bracket assemblies, and the rear discharge door rests firmly against the top of the grass catcher.

### Removing Grass Catcher

- Lift the rear discharge door on the mower.
- Lift the grass catcher up, out of the slots in the handle bracket assemblies.
- Reinstall the plastic rear mulching baffle.
- Release the rear discharge door.

## Converting to Side-Discharge

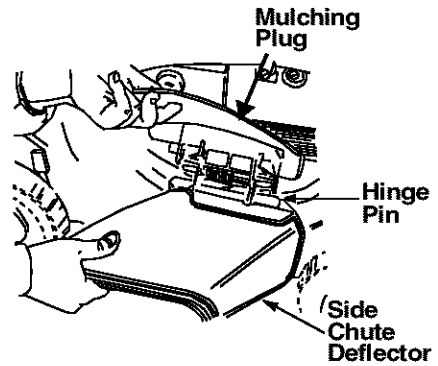

Figure 10

- Your mower has been shipped as a mulcher. To convert it to a side-discharge mower, lift the mulching plug. Slide the two hooks on the side-discharge deflector under the hinge pin on the mulching plug assembly. Lower the mulching plug. See Figure 10 .
- Do not remove the side mulching plug at any time, even when you are not mulching.

## SECTION 4: KNOW YOUR LAWN MOWER

Read this owner's manual and safety rules before operating your lawn mower. Compare the illustrations in Figure 11 with your lawn mower to familiarize yourself with the location of various controls and adjustments.

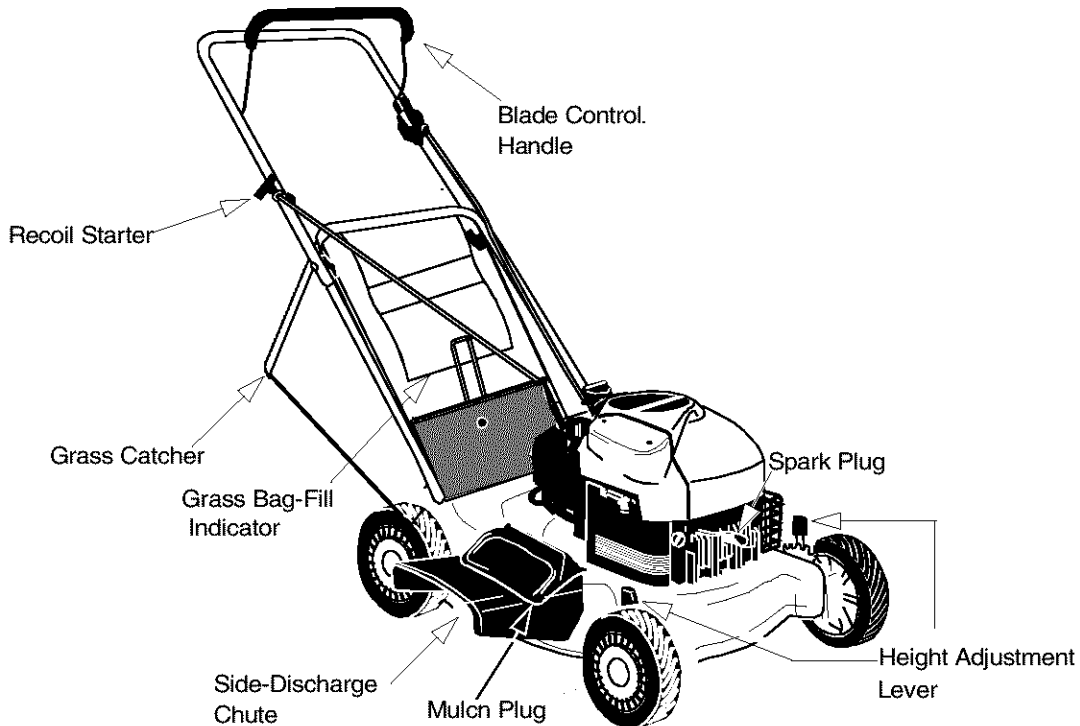

Figure 11

### Blade Control Handle

The blade control handle is located on the upper handle of the mower. The blade control handle must be depressed in order to operate the unit. Release the blade control handle to stop the engine and the blade.



**WARNING:** The blade control handle is a safety device. Never attempt to bypass its operations. The blade will be rotating whenever the engine is running.

### Cutting Height Adjustment Lever

This lever, located at each wheel, lets you adjust cutting height of the grass. Remember to put all four levers at the same height to avoid uneven cut.

### Throttle Control

The engine is equipped with a constant speed throttle for maximum engine and cutting performance.

### Recoil Starter

The recoil starter is attached to the handle. Stand behind the unit and pull the recoil starter to start engine.

### Primer

The primer is used to pump gas into the carburetor. Use it to assist in starting a cold engine, but do not use it when restarting a warm engine after a short shutdown.

### Mulching Plug

Both the mulching baffle and the mulching plug are used only for mulching purposes. Instead of collecting the grass clippings in a grass catcher, some mower models have the option of recirculating the clippings back to the lawn. This is called mulching.

### Grass Bag Fill Indicator

The grass bag is equipped with a bag-fill indicator to add convenience to your work. While the mower is running, air will flow through the bag and into the "sail." If the grass catcher is **empty**, air flows through easily pushing the sail up. If the grass catcher is **full**, air does not flow through it allowing the sail to fall. So the position of the sail acts as a bag-fill indicator signifying when to empty the grass bag.



**WARNING:** Do not operate the mower without the mulching cover, the grass catcher bag, or the discharge chute properly installed.

## SECTION 5: OPERATING YOUR LAWN MOWER

### Before Starting Mower



**WARNING:** Never fill fuel tank indoors, or when engine is running or hot. Do not smoke when filling up the fuel tank.

- Service the engine with gasoline and oil as instructed in the separate engine manual packed with your mower. Read instructions carefully.
- Attach spark plug wire to spark plug. Make certain the metal cap on the end of the spark plug wire (inside the rubber boot) is fastened securely over the metal tip on the spark plug.

### Starting Engine



**WARNING:** Be sure no one other than the operator is standing near the lawn mower while starting engine or operating mower.

**WARNING:** Never run engine indoors or in enclosed, poorly ventilated areas. Engine exhaust contains carbon monoxide, an odorless and deadly gas.

**WARNING:** Keep hands, feet, hair and loose clothing away from any moving parts on engine and lawn mower.

- Push the primer three times. Wait two seconds between each push. In temperatures below 55° F, prime five times. Do not prime to restart a warm engine after a short shutdown.
- Standing behind the mower, depress the blade control handle and hold it against the upper handle.
- Grasp starter handle and pull rope out until engine reaches start of compression cycle (rope will pull slightly harder at this point). Let the rope rewind slowly. Pull rope with a rapid, continuous, full arm stroke. Keeping a firm grip on the starter handle, let the rope rewind slowly.

### Stopping Engine

- Release blade control handle to stop the engine and the blade.
- Disconnect spark plug wire and move away from spark plug to prevent accidental starting.

### Operating Your Lawn Mower

- Once the engine has started, squeeze the blade control handle against the upper handle to run the lawn mower.

- Be sure that the lawn is clear of stones, sticks, wire, or other objects which could damage lawn mower or engine. Such objects could be accidentally thrown by the mower in any direction and cause serious personal injury to the operator and others.
- For best results, **do not** cut wet grass because it tends to stick to the underside of the mower, preventing proper discharge of grass clippings, poor mulching conditions, and could cause you to slip and fall. New grass, thick grass, or wet grass may require a narrower cut.
- For a healthy lawn, always cut off one-third or less of the total length of the grass. Lawn should be trimmed in fall as long as there is growth.



**WARNING:** If you strike a foreign object, stop the engine. Remove spark plug wire from spark plug, thoroughly inspect the mower for any damage. Repair the damage before restarting and operating the mower. Extensive vibration of the mower during operation is an indication of damage.

### Bagging Grass Clippings

- Attach the grass catcher following instructions on page 8 of this manual. Grass clippings will automatically collect in the bag as you run mower.
- Operate mower till the grass bag is full. Refer to page 10 for description of flow indicator.
- Stop the engine completely by releasing the control handle. Make sure that the unit has come to a complete stop.
- Lift discharge door and pull grass bag up and away from the mower to dispose of the grass clippings.

### Using the Mulcher

- For effective mulching, do not cut wet grass because it tends to stick to the underside of the deck, preventing proper mulching of grass clippings. New or thick grass may require a narrower cut. The ground speed should be adjusted to the condition of the lawn. If mowing has been delayed and the grass has been allowed to grow in excess of 4", mulching is not recommended. Mow using the grass bag (if so equipped) to reduce the grass height to 3-1/4" maximum before mulching.

### Adjusting Cutting Height

Refer to height adjustments section of this manual on page 14 for instruction on how to adjust the cutting height and the handle height.

## SECTION 6: MAINTAINING YOUR LAWN MOWER



**WARNING:** Always stop engine and disconnect spark plug wire before performing any maintenance or adjustments on the mower.

**WARNING:** Never tip mower more than 90 degrees in any direction and do not leave it tipped for long. Oil can drain into the upper part of the engine causing a starting problem.

### Cleaning the Lawn Mower

- Clean underside of the mower deck after each use to prevent any build-up of grass. If this debris accumulates, it will cause rust and corrosion.

**NOTE:** We do not recommend the use of pressure washers or garden hose to clean your unit. These may cause damage to electric components, spindles, pulleys, bearings or the engine. The use of water will result in shortened life and reduced serviceability.

- Disconnect spark plug wire. Drain gasoline from the mower, or place a piece of plastic under gas cap.
- Tilt the mower so that the side with the air cleaner is facing up. Hold the mower firmly.
- Scrape and clean the underside of the deck with a suitable tool. Do not spray with water.
- Put mower back on its wheels and remove plastic.

### Engine Maintenance

A list of key maintenance jobs required for good performance by the mower is given below. Follow the engine manual for detailed list and instructions.

- Change engine oil as specified in the engine manual. Check oil level before starting engine every time.
- Service foam filter in the air cleaner as specified in the engine manual. Service air filter more frequently in extremely dusty conditions.
- Clean engine periodically. Remove dirt and debris with a cloth or brush.
- Clean spark plug and reset the gap to .030" at least once a season or every 50 hours of operation.
- Inspect muffler periodically, and replace if necessary. Damaged mufflers or spark arresters can create a **fire hazard**.

**IMPORTANT:** Make sure to avoid muffler and surrounding areas while the mower engine is hot because temperature of these areas of the engine may exceed 150° F.

### Lubrication

(See Figure 12 )

#### Wheels

- Lubricate the wheels and bearings, if so equipped, at least once a season with light oil or engine oil. Also, if the wheels are removed for any reason, lubricate the surface of the axle bolt and the inner surface of the wheel with light oil.

#### Chute Deflector & Rear Discharge Door

- Lubricate the torsion spring and the pivot point on each end of the rear discharge door using a light oil. This will prevent rusting.

#### Engine

- Follow the engine manual instructions and recommended schedule for lubricating engine.

#### Pivot Points

- Lubricate the pivot points on the discharge chute door, blade control handle and the cutting height adjustment lever at least once a season with light oil. The blade control handle must operate freely in both directions. The cutting height adjustment levers should be able to move easily.

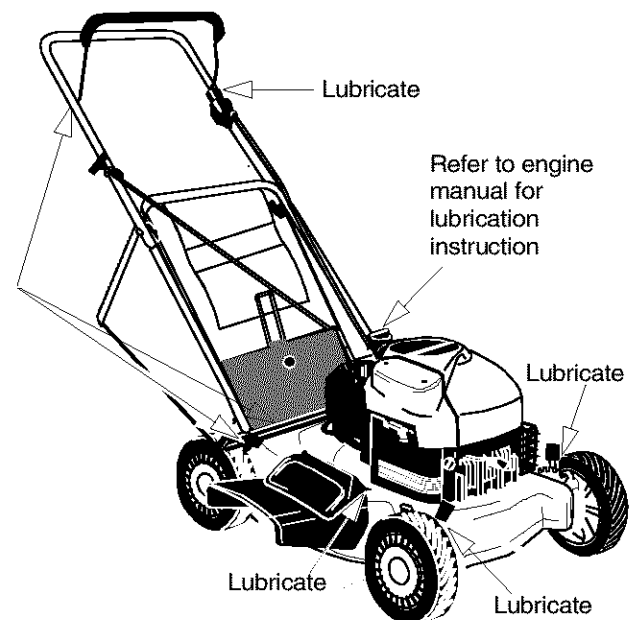

Figure 12

## SECTION 7: SERVICING YOUR MOWER

### Blade Care

Periodically inspect the blade adapter and pulley for cracks, especially if you strike a foreign object. Replace when necessary.



**WARNING:** When removing the cutting blade for sharpening or replacement, protect hands by using heavy gloves or a thick rag to grasp the cutting blade.

- Disconnect spark plug wire from spark plug.
- Turn mower on its side making sure that the air filter and the carburetor are up.
- Remove the bolt and blade support which hold the blade and adapter to the engine crankshaft. See Figure 13. Remove the blade and the adapter from the crankshaft.

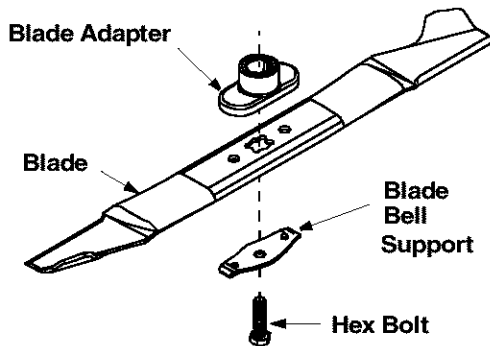

Figure 13

#### To Sharpen Blade:

- The blade can be sharpened with a file or on a grinding wheel. Do not attempt to sharpen the blade while it is still on the mower.
- Follow the original angle of grind as a guide. Make sure that each cutting edge receives an equal amount of grinding to prevent an unbalanced blade.

**NOTE:** An unbalanced blade will cause excessive vibration when rotating at high speeds, may cause damage to the mower and could break causing personal injury.

- The blade can be tested by balancing it on a round shaft screwdriver. See Figure 14. Remove metal from the heavy side until it balances evenly. It is recommended that the blade always be removed from the adapter for the best test of balance.

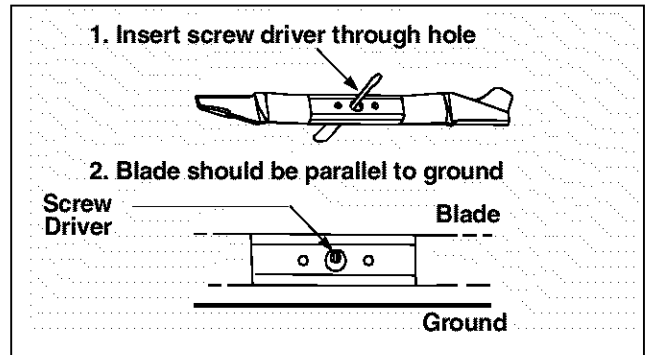

Figure 14

- Before reassembling the blade and the blade adapter to the unit, lubricate the engine crankshaft and the inner surface of the blade adapter with light oil (or engine oil). Also lubricate the bolt holes, bolts and inner surface of the nuts.
- Install the blade adapter on the crankshaft with the “star” away from the engine. Refer to Figure 13. Place the blade with the side marked bottom (or with part number) facing away from the adapter.
- Align the blade bell support over the blade with the tabs in the holes of the blade and insert the hex bolt. Tighten the hex bolt to the torque listed in the “Blade Mounting Torque” section below.

#### Blade Mounting Torque

Center Bolt: 450 in. lbs. min., 600 in. lbs. max.

**IMPORTANT:** To ensure safe operation, all nuts and bolts must be checked periodically for correct tightness.

### Replacing Rear Flap

- To remove rear flap, cut off the flat end of the wire rod which secures it to the deck. See Figure 15.
- Attach the new flap and new rod to deck, bending the ends of the new rod over to secure to deck.

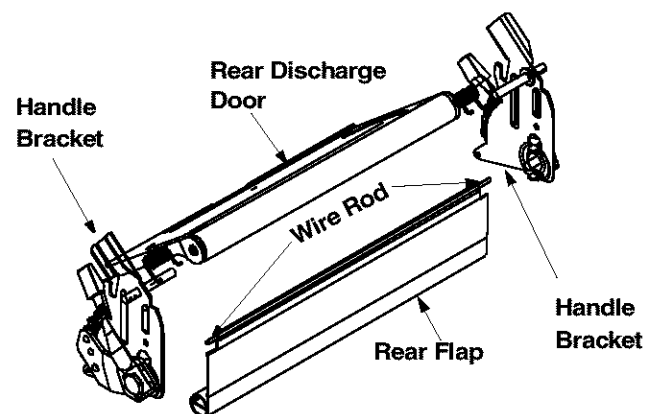

Figure 15

## SECTION 8: MAKING ADJUSTMENTS

### Adjusting Handle Height

Your mower is shipped with the handle in the higher height position. To lower height, proceed as follows.

- Remove the starter rope from the rope guide.
- Remove the upper handle by removing the hand knobs and carriage bolts. Lay upper handle out of the way, being careful not to bend or kink cables.
- Remove the hairpin clips from the weld pins on the handle brackets. Refer to Figure 4. Press out on the legs of the lower handle. Remove lower handle from the mower.
- Turn the lower handle around so the notch on the bottom of the lower handle is facing forward as shown in Figure 16 . Reassemble, placing the bottom holes in the handle over the weld pins in the handle mounting bracket.
- Reassemble the upper handle to the lower handle.
- Insert hairpin clips in the inner holes of the weld pins and attach the starter rope as instructed in the "Assembling Your Lawn Mower" section.

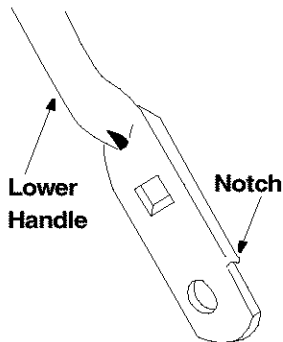

Figure 16

### Adjusting Cutting Height

**IMPORTANT:** All wheels must be placed in the same relative position. For rough or uneven lawns, move the

height adjustment lever to a higher position. This will help stop scalping of the grass.

An adjusting plate and thumb lever at each wheel position provides cutting height adjustment. Each adjusting plate has nine height positions. Height of cut will change when you move the thumb lever from one position to another.

- Simply depress the lever towards the wheel and move the lever assembly to desired position. See Figure 17 .

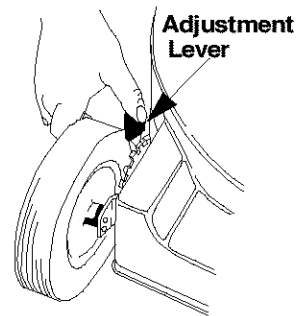

Figure 17

### Adjusting Carburetor

**NOTE:** A dirty air cleaner may cause an engine to run rough too. Make sure that the air cleaner is clean and attached to the carburetor before deciding to adjust the carburetor.



**WARNING:** If any adjustments are made to the engine (e.g. carburetor) while the engine is running, keep clear of all moving parts. Be careful of heated surfaces like the muffler.

To adjust carburetor, please follow the engine manual.

## SECTION 9: OFF-SEASON STORAGE

Prepare your lawn mower for storage at the end of the season or **if the unit will not be used for 30 days** or more. Store the mower in a **clean, dry area**.

### Gasoline

- Do not store gasoline from one season to another. Gasoline, stored more than one month, may affect engine performance.
- Replace your gasoline can if it starts to rust. Rust and/or dirt in the gasoline will cause problems.

### Engine

- Follow recommendations in the accompanying engine manual for off-season storage of the engine.

### Mower

**NOTE:** *If storing the mower in an unventilated or metal storage shed, make sure to rustproof the equipment with a light oil or silicone.*

- Store unit in a clean, dry area. Do not store next to corrosive materials, such as fertilizer or rocksalt.
- Clean underside of the mower according to instructions on page 12 .

**NOTE:** *We do not recommend the use of pressure washers or garden hose to clean your unit. They may cause damage to electric components, spindles, pulleys, bearings or the engine. The use of water will result in shortened life and reduce serviceability.*

- Lubricate the mower as instructed on page 12.
- You can fold your mower's handle for convenience of storage .
- Inspect and replace/sharpen blade, if required. Refer to page 13.

## SECTION 10: TROUBLE-SHOOTING GUIDE

Problem	Possible Cause	Corrective Action
Engine fails to start	<ol style="list-style-type: none"> <li>Blade control handle disengaged</li> <li>Spark plug wire disconnected</li> <li>Fuel tank empty, or stale fuel</li> <li>Blocked fuel line</li> <li>Faulty spark plug</li> <li>Engine flooded</li> </ol>	<ol style="list-style-type: none"> <li>Engage blade control handle</li> <li>Connect wire to spark plug</li> <li>Fill up tank with fresh gasoline</li> <li>Clean fuel line</li> <li>Clean, adjust gap, or replace</li> <li>Wait a few minutes and start again.</li> </ol>
Engine runs erratic	<ol style="list-style-type: none"> <li>Spark plug wire loose</li> <li>Blocked fuel line or stale fuel</li> <li>Vent in gas cap plugged</li> <li>Water or dirt in fuel system</li> <li>Dirty air cleaner</li> </ol>	<ol style="list-style-type: none"> <li>Connect and tighten spark plug wire.</li> <li>Clean fuel line, fill tank with clean, fresh gasoline.</li> <li>Clear vent.</li> <li>Drain fuel tank. Refill with fresh fuel.</li> <li>Clean air cleaner. Refer to engine manual.</li> </ol>
Engine overheats	<ol style="list-style-type: none"> <li>Engine oil level low</li> <li>Air flow restricted</li> </ol>	<ol style="list-style-type: none"> <li>Fill crankcase with proper oil.</li> <li>Clean lawn mower engine.</li> </ol>
Occasional skip at high speed	<ol style="list-style-type: none"> <li>Spark plug gap too close</li> </ol>	<ol style="list-style-type: none"> <li>Adjust gap to .030 inches.</li> </ol>
Idles poorly	<ol style="list-style-type: none"> <li>Spark plug fouled, faulty, or gap too wide</li> <li>Dirty air cleaner</li> </ol>	<ol style="list-style-type: none"> <li>Reset gap or replace spark plug.</li> <li>Clean air cleaner.</li> </ol>
Excessive vibration	<ol style="list-style-type: none"> <li>Cutting blade loose or unbalanced</li> <li>Bent cutting blade</li> <li>Bent engine crankshaft</li> </ol>	<ol style="list-style-type: none"> <li>Tighten blade and adapter, balance blade.</li> <li>Replace blade.</li> <li>Contact your nearest service center</li> </ol>
Fails to mulch grass	<ol style="list-style-type: none"> <li>Wet grass</li> <li>Excessively high grass</li> <li>Dull blade</li> </ol>	<ol style="list-style-type: none"> <li>Wait until grass is dry to cut.</li> <li>Mow once at a high cutting height, then mow again at desired height.</li> <li>Sharpen or replace blade.</li> </ol>
Uneven cut	<ol style="list-style-type: none"> <li>Wheels not in same height position</li> <li>Dull blade</li> </ol>	<ol style="list-style-type: none"> <li>Reposition all wheels at same height.</li> <li>Sharpen or replace blade.</li> </ol>

**NOTE:** *For repairs beyond the minor adjustments listed above, contact your nearest authorized service dealer.*

# SECTION 11: PARTS LIST FOR MODEL 436

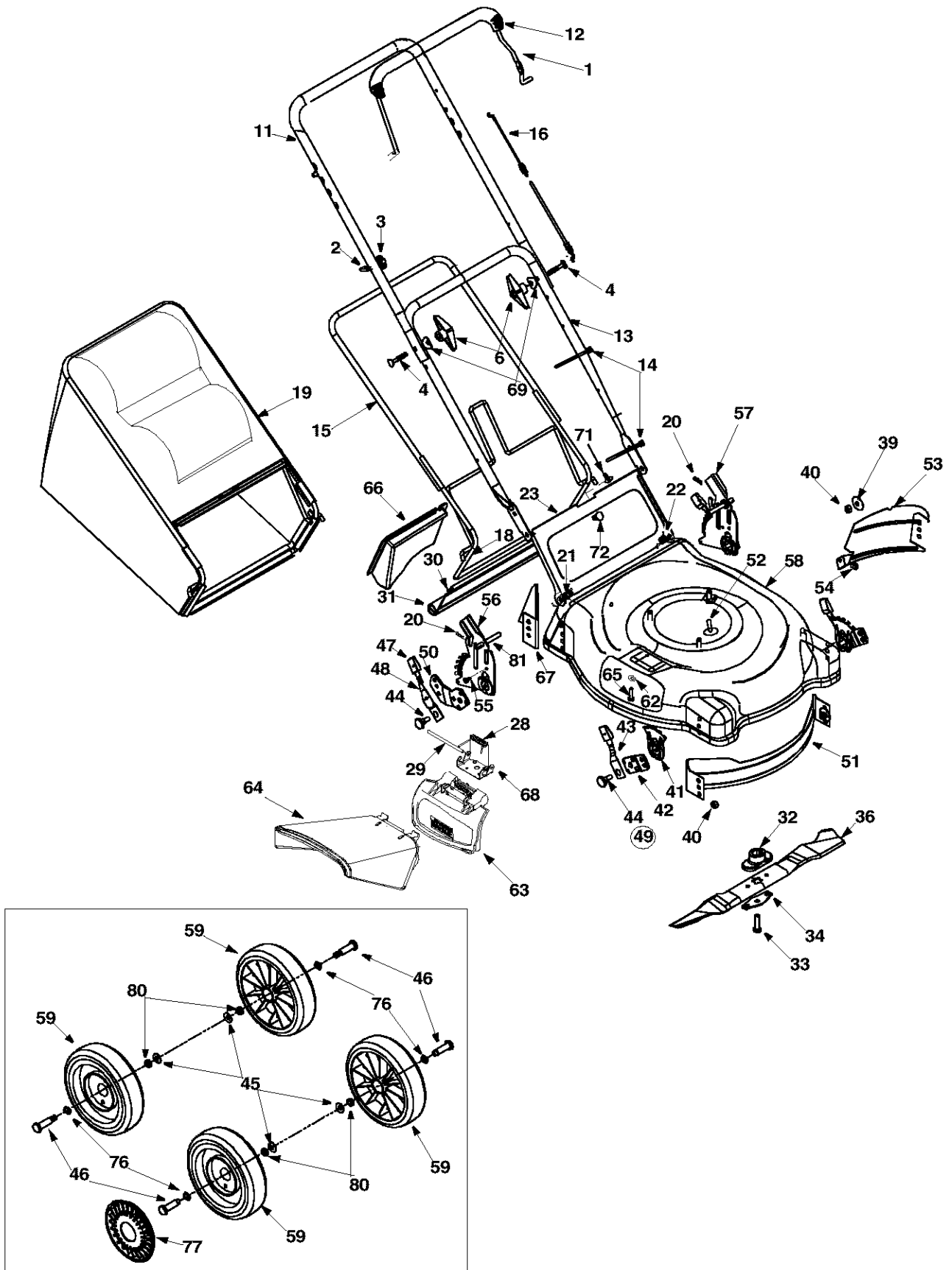



# Model 436

Ref. No	Part No.	Description	Ref. No	Part No.	Description
1	747-1161A	Control Handle	46	738-0213	Axle Bolt
2	710-1205	Rope Guide	47	720-0426	Spring Lever Knob
3	720-0279	Handle Knob 1/4-20 Thd.	48	732-0404	Rear Spring Lever
4	710-1174	Curved Hd. Bolt 5/16-18 x 2"	49	14578	Height Adj. Assy. Comp. - RH
6	720-0284	Hand Knob		14579	Height Adj. Assy. Comp. - LH ‡
11	749-1092A	Upper Handle	50	14765	Pivot Bar R.H.
12	731-2626	Bail Cover	N/I	14766	Pivot Bar L.H.
13	749-0928	Lower Handle	51	782-5002	Front Baffle
14	726-0240	Cable Tie	52	710-0654A	Hex L-Wash.Scr. 3/8-16 x 1"
15	764-0310	Rear Catcher Frame	53	782-5003	Rear Baffle
16	746-1130	Control Cable - 40"	54	710-1017	Torx Mach AB-Tap Scr. 1/4 x .625"
18	764-0311	Front Catcher Frame	55	710-0896	HexIndWash. Scr. 1/4-14: .625
19	664-0176	Grass Bag Assembly: Half Sail	56	682-0516A	Handle Brkt. Ass'y.—RH
20	714-0104	Int. Cotter Pin 5/16" Dia.	57	682-0515A	Handle Brkt. Ass'y.—LH
21	732-0678	Door Spring - R.H.	58	782-0047A	Cutting Deck
22	732-0677	Door Spring - L.H.	59	734-2004A	Wheel
23	782-7000	Rear Discharge Door	62	736-0270	Bell Washer 1/4" I.D.
28	732-0731	Torsion Spring	63	731-1404A	Hinged Mulching Plug
29	747-0710	Hinge Pin	64	731-1409	Chute Deflector: Side Discharge
30	732-0700	Wire Rod	65	710-0599	Hex Hd Self-Tp Scr. 1/4-20 x .5"
31	731-1236	Rear Flap	66	782-5007A	Mulching Baffle Plug
32	753-0588	Blade Adapter (Kit includes 32-34)	67	782-5004	Mulching Baffle - R.R.
	748-0376C	Blade Adapter	68	782-7006	Mounting Bracket
33	710-1044	Hex Bolt 3/8-24 x 1.5" Lg.	69	736-0451	Saddle Washer
34	736-0524A	Blade Bell Support	71	710-0192	Truss Scr. #10-24 x .38" Lg.
36	742-0741	21" Mulching Blade	72	720-0275	Knob
40	712-0431	Flange Nut 3/8-16 Thd.*	76	736-0504	Wave Washer
41	15261A	Height Adj. Plate	77	731-0981A	Hub Cap:Grey
42	15262B	Pivot Bar	80	750-0535	Spacer
43	14832	Front Spring Lever Ass'y. w/Knob	81	710-1248	Weld Pin
44	738-0507B	Shld. Bolt .5" Dia. x .357"	—	735-0639	Spark Plug Boot ‡
45	736-0105	Bell Washer .38" I.D. x .88" O.D.			

‡ Not shown

# Safety & Decorative Labels

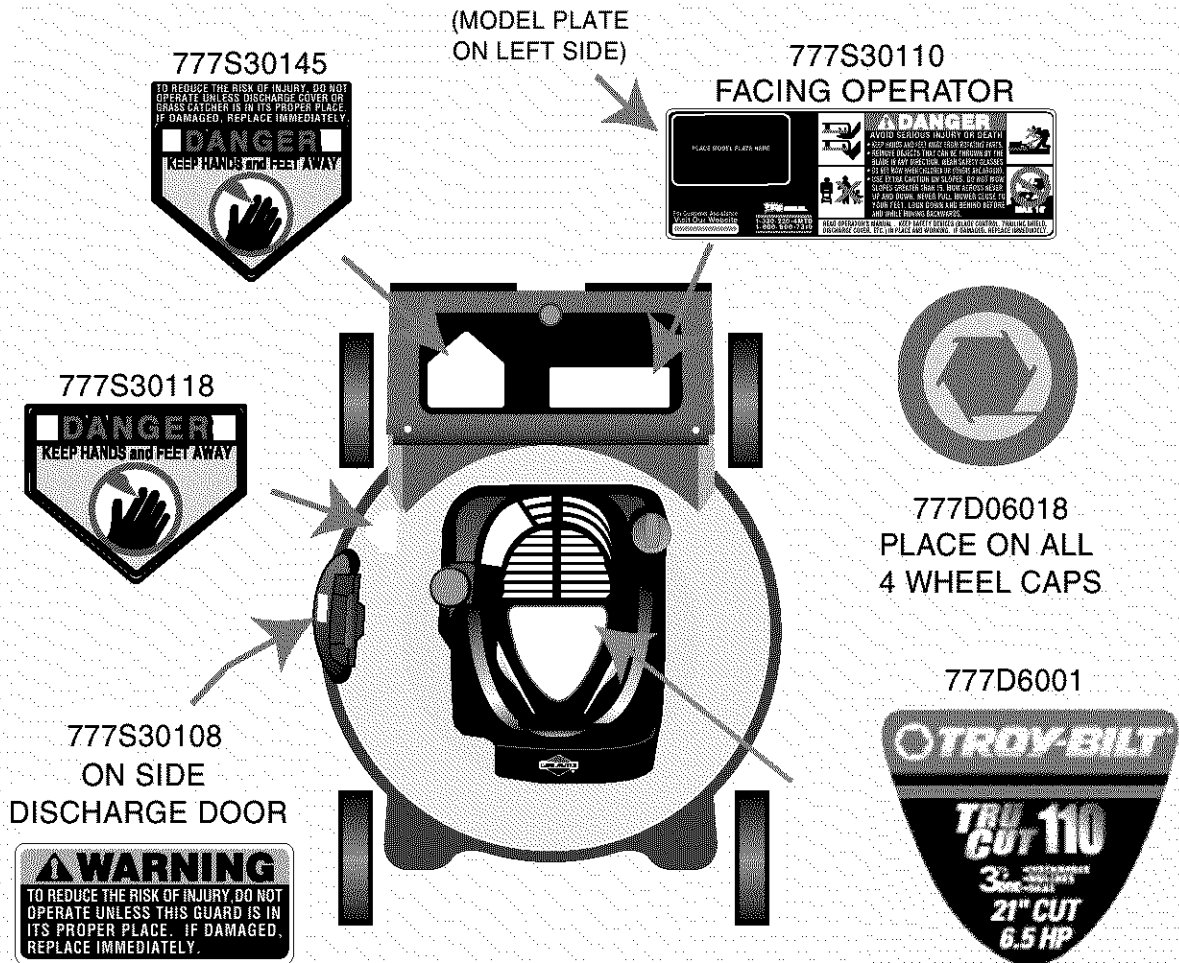



# MANUFACTURER'S LIMITED WARRANTY FOR:



The limited warranty set forth below is given by Troy-Bilt LLC with respect to new merchandise purchased and used in the United States, its possessions and territories.

Troy-Bilt LLC warrants this product against defects for a period of two (2) years commencing on the date of original purchase and will, at its option, repair or replace, free of charge, any part found to be defective in materials or workmanship. This limited warranty shall only apply if this product has been operated and maintained in accordance with the Operator's Manual furnished with the product, and has not been subject to misuse, abuse, commercial use, neglect, accident, improper maintenance, alteration, vandalism, theft, fire, water, or damage because of other peril or natural disaster. Damage resulting from the installation or use of any accessory or attachment not approved by Troy-Bilt LLC for use with the product(s) covered by this manual will void your warranty as to any resulting damage.

Normal wear parts or components thereof are subject to separate terms as follows: All normal wear parts or component failures will be covered on the product for a period of 90 days regardless of cause. After 90 days, but within the two year period, normal wear part failures will be covered ONLY IF caused by defects in materials or workmanship of OTHER component parts. Normal wear parts and components include, but are not limited to: batteries, belts, blades, blade adapters, grass bags, rider deck wheels, seats, snow thrower skid shoes, shave plates, auger spiral rubber, and tires.

**HOW TO OBTAIN SERVICE:** Warranty service is available, WITH PROOF OF PURCHASE, through your local authorized service dealer. To locate the dealer in your area, check your Yellow Pages, or contact Troy-Bilt LLC at P.O. Box 361131, Cleveland, Ohio 44136-0019, or call 1-866-840-6483 or 1-330-558-7220, or log on to our Web site at [www.troybilt.com](http://www.troybilt.com).

This limited warranty does not provide coverage in the following cases:

- a. The engine or component parts thereof. These items carry a separate manufacturer's warranty. Refer to applicable manufacturer's warranty for terms and conditions.
- b. Log splitter pumps, valves, and cylinders have a separate one year warranty.
- c. Routine maintenance items such as lubricants, filters, blade sharpening, tune-ups, brake adjustments, clutch adjustments, deck adjustments, and normal deterioration of the exterior finish due to use or exposure.
- d. Troy-Bilt LLC does not extend any warranty for products sold or exported outside of the United States, its possessions and territories, except those sold through Troy-Bilt LLC's authorized channels of export distribution.
- e. Parts that are not genuine Troy-Bilt parts are not covered by this warranty.
- f. Service completed by someone other than an authorized service dealer is not covered by this warranty.
- g. Transportation charges and service calls are not covered.

**No implied warranty, including any implied warranty of merchantability of fitness for a particular purpose, applies after the applicable period of express written warranty above as to the parts as identified. No other express warranty, whether written or oral, except as mentioned above, given by any person or entity, including a dealer or retailer, with respect to any product, shall bind Troy-Bilt LLC. During the period of the warranty, the exclusive remedy is repair or replacement of the product as set forth above.**

**The provisions as set forth in this warranty provide the sole and exclusive remedy arising from the sale. Troy-Bilt LLC shall not be liable for incidental or consequential loss or damage including, without limitation, expenses incurred for substitute or replacement lawn care services or for rental expenses to temporarily replace a warranted product.**

Some states do not allow the exclusion or limitation of incidental or consequential damages, or limitations on how long an implied warranty lasts, so the above exclusions or limitations may not apply to you.

In no event shall recovery of any kind be greater than the amount of the purchase price of the product sold. **Alteration of safety features of the product shall void this warranty.** You assume the risk and liability for loss, damage, or injury to you and your property and/or to others and their property arising out of the misuse or inability to use the product.

This limited warranty shall not extend to anyone other than the original purchaser or to the person for whom it was purchased as a gift.

**HOW STATE LAW RELATES TO THIS WARRANTY:** This limited warranty gives you specific legal rights, and you may also have other rights which vary from state to state.

**Troy-Bilt LLC, P.O. BOX 361131 CLEVELAND, OHIO 44136-0019; Phone: 1-866-840-6483, 1-330-558-7220**