

Cub Cadet®

Operator's Manual



2-Cycle Trimmer
Model CC 3075

IMPORTANT: READ SAFETY RULES AND INSTRUCTIONS CAREFULLY

Table of Contents

Content	Page
Section 1: Safety	3
Section 2: Know Your Unit	6
Section 3: Assembly	7
Section 4: Oil and Fuel	8
Section 5: Operation	9
Section 6: Maintenance.	12
Section 7: Troubleshooting	18
Section 8: Specifications.	19
Warranty Information	24

To the Owner

Thank you for buying this quality product. This modern outdoor power tool will provide many hours of useful service. You will find it to be a great labor-saving device. This operator's manual provides you with easy-to-understand operating instructions. Before starting or operating this equipment, read the whole manual and follow all the instructions to keep your new outdoor power tool in top operating condition.

All information, illustrations and specifications in this manual are based on the latest product information available at the time of printing. We reserve the right to make changes at any time without notice. Service on this unit both within and after the warranty period should be performed only by a Cub Cadet dealer. **Proof of purchase will be required for warranty service.**

NOTE: For users on U.S. Forest Land and in the states of California, Maine, Oregon and Washington. All U.S. Forest Land and the state of California (Public Resources Codes 4442 and 4443), Oregon and Washington require, by law that certain internal combustion engines operated on forest brush and/or grass-covered areas be equipped with a spark arrestor, maintained in effective working order, or the engine be constructed, equipped and maintained for the prevention of fire. Check with your state or local authorities for regulations pertaining to these requirements. Failure to follow these requirements could subject you to liability or a fine. **This unit is factory equipped with a spark arrestor.** If it requires replacement, **Accessory Part #181696 Spark Arrestor Screen is available by contacting the service department.**

Finding the Model Number

Before you start assembling your new equipment, please locate the model plate on the equipment and copy the information from it in the space provided below. This information is very important if you need help from our Customer Support Department or an authorized dealer.

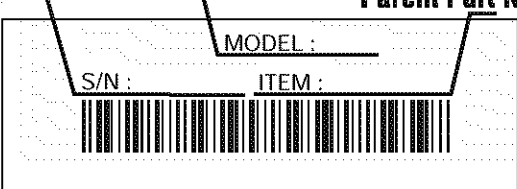
Serial Number	Model Number	Parent Part Number	Copy the model and parent part number here: _____
			

Calling Customer Support

If you have difficulty assembling this product or have any questions regarding the controls, operation or maintenance of this unit, please call the Customer Support Department.



Call **1-877-282-8684** to reach a Customer Support representative. Please have your unit's model number and serial number ready when you call. See the previous section to locate this information.

Copyright© 2003 Cub Cadet LLC
All Rights Reserved

For more details about your unit, visit our website at www.cubcadet.com

Safety

The purpose of safety symbols is to attract your attention to possible dangers. The safety symbols, and their explanations, deserve your careful attention and understanding. The safety warnings do not by themselves eliminate any danger. The instructions or warnings they give are not substitutes for proper accident prevention measures.

SYMBOL	MEANING
--------	---------



SAFETY ALERT SYMBOL: Indicates danger, warning or caution. Attention is required in order to avoid serious personal injury. May be used in conjunction with other symbols or pictographs.

NOTE: Advises you of information or instructions vital to the operation or maintenance of the equipment.

California Proposition 65 Warning

WARNING

THE ENGINE EXHAUST FROM THIS PRODUCT CONTAINS CHEMICALS KNOWN TO THE STATE OF CALIFORNIA TO CAUSE CANCER, BIRTH DEFECTS OR OTHER REPRODUCTIVE HARM.

DANGER

Failure to obey a safety warning will result in serious injury to yourself or to others. Always follow the safety precautions to reduce the risk of fire, electric shock, and personal injury.

WARNING

Failure to obey a safety warning can result in injury to yourself and others. Always follow the safety precautions to reduce the risk of fire, electric shock, and personal injury.

CAUTION

Failure to obey a safety warning may result in property damage or personal injury to yourself or to others. Always follow the safety precautions to reduce the risk of fire, electric shock, and personal injury.

Important Safety Information

READ ALL INSTRUCTIONS

Before Operating

- Read the instructions carefully. Be familiar with the controls and proper use of the unit.
- Do not operate this unit when tired, ill or under the influence of alcohol, drugs or medication.
- Children and teens under the age of 15 must not use the unit, except for teens guided by an adult.
- Inspect the unit before use. Replace damaged parts. Check for fuel leaks. Make sure all fasteners are in place and secure. Replace cutting attachment parts that are cracked, chipped or damaged in any way. Make sure the cutting attachment is properly installed and securely fastened. Be sure the cutting attachment shield is properly attached, and positioned as recommended. Failure to do so can result in personal injury to the operator and bystanders, as well as damage to the unit.
- Be aware of the risk of injury to the head, hands and feet.
- Use only 0.105 inch (2.67 mm) diameter original equipment manufacturer replacement line. Never use metal-reinforced line, wire or rope. These can break off and become dangerous projectiles.
- Clear the area to be cut before each use. Remove all objects such as rocks, broken glass, nails, wire or string. They can be thrown or become entangled in the cutting attachment. Clear the area of children, bystanders, and pets. At a minimum, keep all children, bystanders and pets outside a 50-foot (15 m.) radius; there still may be a risk to bystanders from thrown objects. Bystanders should be encouraged to wear eye protection. If you are approached, stop the engine and cutting attachment immediately.
- Squeeze the throttle control and check that it returns automatically to the idle position. Make all adjustments or repairs before using unit.

Safety (continued)

Safety Warnings for Gas Trimmers

WARNING

Gasoline is highly flammable, and its vapors can explode if ignited. Take the following precautions.

- Store fuel only in containers specifically designed and approved for the storage of such materials.
- Always stop the engine and allow it to cool before filling the fuel tank. Never remove the cap of the fuel tank, or add fuel, when the engine is hot. Never operate the unit without the fuel cap securely in place. Loosen the fuel tank cap slowly to relieve any pressure in the tank.
- Add fuel in a clean, well-ventilated outdoor area where there are no sparks or flames. Slowly remove the fuel cap only after stopping engine. Do not smoke while fueling or mixing fuel. Wipe up any spilled fuel from the unit immediately.
- Avoid creating a source of ignition for spilled fuel. Do not start the engine until fuel vapors dissipate.
- Move the unit at least 30 feet (9.1 m) from the fueling source and site before starting the engine. Do not smoke. Keep sparks and open flames away from the area while adding fuel or operating the unit.

While Operating

- Never start or run the unit inside a closed room or building. Breathing exhaust fumes can kill. Operate this unit only in a well ventilated outdoor area.
- Wear safety glasses or goggles that are marked as meeting ANSI Z87.1-1989 standards. Also wear ear/hearing protection when operating this unit. Wear a face or dust mask if the operation is dusty. Long sleeve shirts are recommended.
- Wear heavy, long pants, boots and gloves. Do not wear loose clothing, jewelry, short pants, sandals or go barefoot. Secure hair above shoulder level.
- The cutting attachment shield must always be in place while operating the unit. Do not operate unit without both trimming lines extended, and the proper line installed. Do not extend the trimming line beyond the length of the shield.
- This unit has a clutch. The cutting attachment remains stationary when the engine is idling. If it does not, have the unit adjusted by an authorized service technician.
- Adjust the D-handle to your size to provide the best grip.
- Be sure the cutting attachment is not in contact with anything before starting the unit.
- Use the unit only in daylight or good artificial light.
- Avoid accidental starting. Be in the starting position whenever pulling the starter rope. The operator and unit must be in a stable position while starting. See *Starting/Stopping Instructions*.

- Use the right tool. Only use this tool for the purpose intended.
- Do not overreach. Always keep proper footing and balance.
- Always hold the unit with both hands when operating. Keep a firm grip on both the front and rear handle or grips.
- Keep hands, face, and feet at a distance from all moving parts. Do not touch or try to stop the cutting attachment when it is rotating.
- Do not touch the engine or muffler. These parts get extremely hot from operation. They remain hot for a short time after you turn off the unit.
- Do not operate the engine faster than the speed needed to cut, trim or edge. Do not run the engine at high speed when you are not cutting.
- Always stop the engine when cutting is delayed or when walking from one cutting location to another.
- If you strike or become entangled with a foreign object, stop the engine immediately and check for damage. Do not operate before repairing damage. Do not operate the unit with loose or damaged parts.
- Stop and switch the engine to off for maintenance, repair, or for changing the cutting attachment or other attachments.

Use only original equipment manufacturer replacement parts and accessories for this unit. These are available from your authorized service dealer. Use of any unauthorized parts or accessories could lead to serious injury to the user, or damage to the unit, and void your warranty.

- Keep unit clean of vegetation and other materials. They may become lodged between the cutting attachment and shield.
- To reduce fire hazard, replace faulty muffler and spark arrestor, keep the engine and muffler free from grass, leaves, excessive grease or carbon build up.

Other Safety Warnings

- Never store the unit, with fuel in the tank, inside a building where fumes may reach an open flame or spark.
- Allow the engine to cool before storing or transporting. Be sure to secure the unit while transporting.
- Store the unit in a dry area, locked up or up high to prevent unauthorized use or damage, out of the reach of children.
- Never douse or squirt the unit with water or any other liquid. Keep handles dry, clean and free from debris. Clean after each use. See the *Cleaning and Storage* instructions.
- Keep these instructions. Refer to them often and use them to instruct other users. If you loan someone this unit, also loan them these instructions.

SAVE THESE INSTRUCTIONS

Safety and International Symbols

This operator's manual describes safety and international symbols and pictographs that may appear on this product. Read the operator's manual for complete safety, assembly, operating and maintenance and repair information.

SYMBOL



MEANING

- **SAFETY ALERT SYMBOL**

Indicates danger, warning, or caution. May be used in conjunction with other symbols or pictographs.

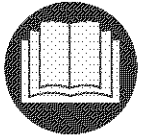

- **WARNING - READ OPERATOR'S MANUAL**

Read the Operator's Manual(s) and follow all warnings and safety instructions. Failure to do so can result in serious injury to the operator and/or bystanders.



- **WEAR EYE AND HEARING PROTECTION**

WARNING: Thrown objects and loud noise can cause severe eye injury and hearing loss. Wear eye protection meeting ANSI Z87.1-1989 standards and ear protection when operating this unit. Use a full face shield when needed.



- **KEEP BYSTANDERS AWAY**

WARNING: Keep all bystanders, especially children and pets, at least 50 feet (15 m.) from the operating area.



- **UNLEADED FUEL**

Always use clean, fresh unleaded fuel.



- **OIL**

Refer to operator's manual for the proper type of oil.

SYMBOL



MEANING

- **THROWN OBJECTS AND ROTATING CUTTER CAN CAUSE SEVERE INJURY**

WARNING: Do not operate without the cutting attachment shield in place. Keep away from the rotating cutting attachment.



- **ON/OFF STOP CONTROL**

ON / START / RUN

- **ON/OFF STOP CONTROL**

OFF or STOP



- **HOT SURFACE WARNING**

Do not touch a hot muffler or cylinder. You may get burned. These parts get extremely hot from operation. When turned off they remain hot for a short time.



- **SHARP BLADE**

WARNING: Sharp blade on cutting attachment shield. To prevent serious injury, do not touch line cutting blade.

Section 2

Know Your Unit

Applications

As a trimmer:

- Cutting grass and light weeds
- Edging
- Decorative trimming around trees, fences, etc.

With the optional brushcutter accessory kit:

- Cutting weeds and light bush of up to 1/2 inch in diameter

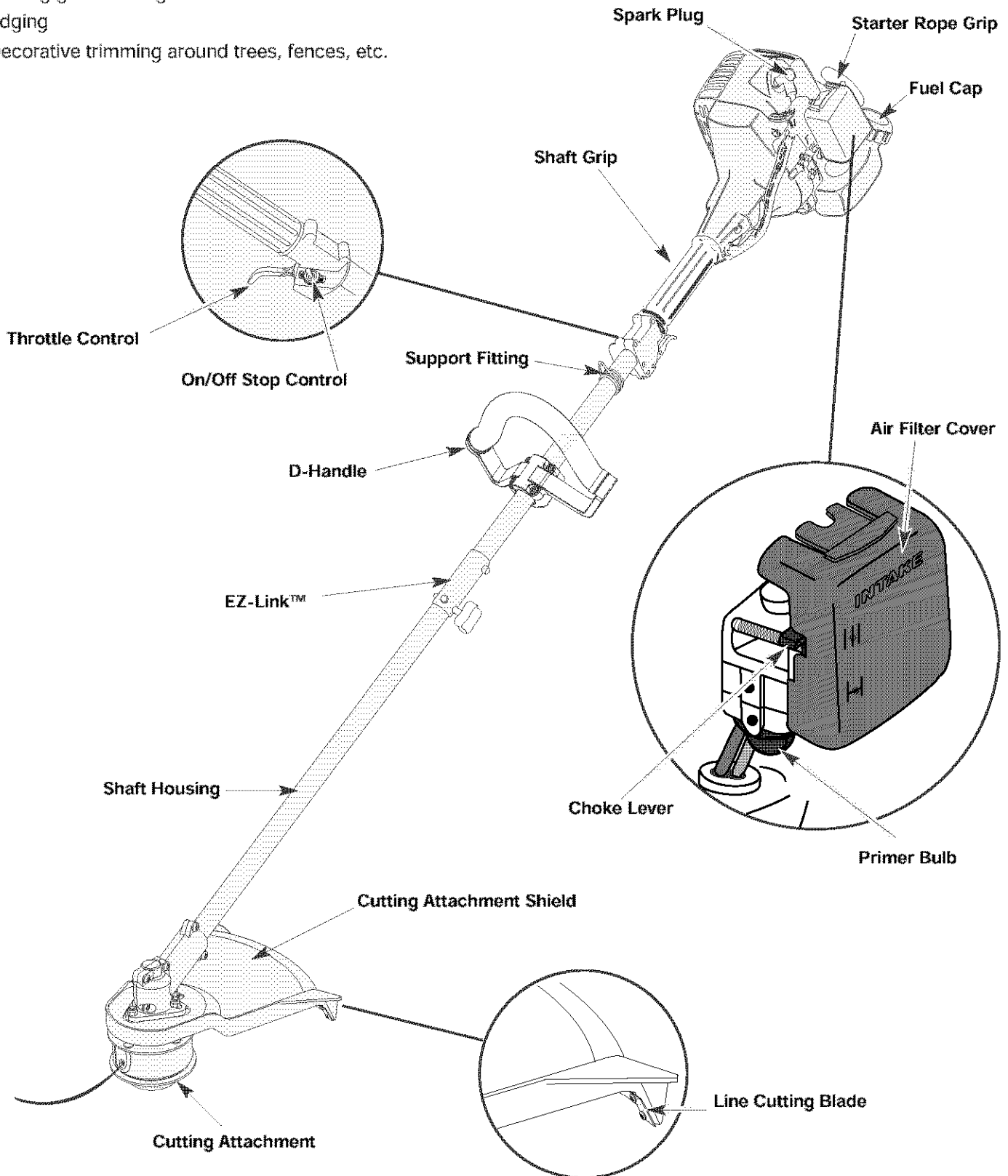



Assembly

Install and Adjust the D-handle

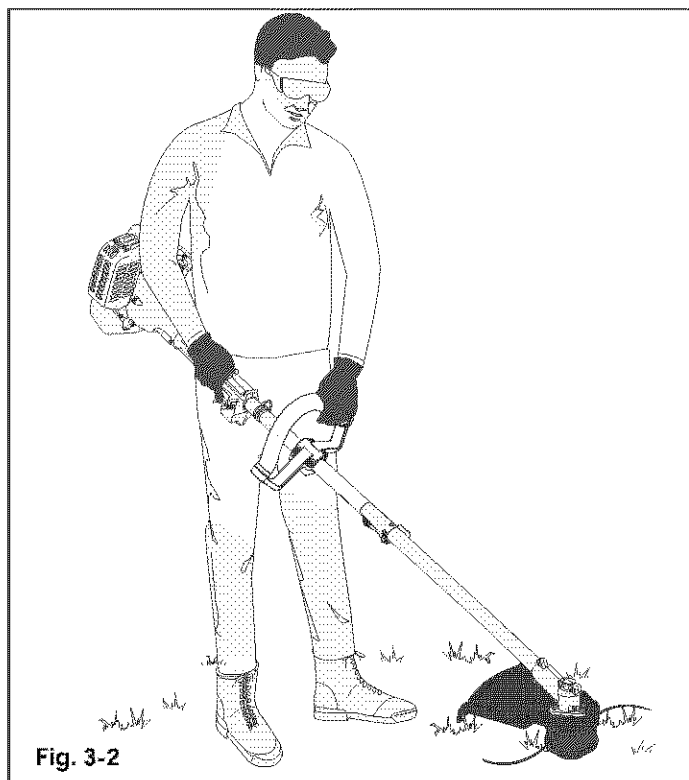
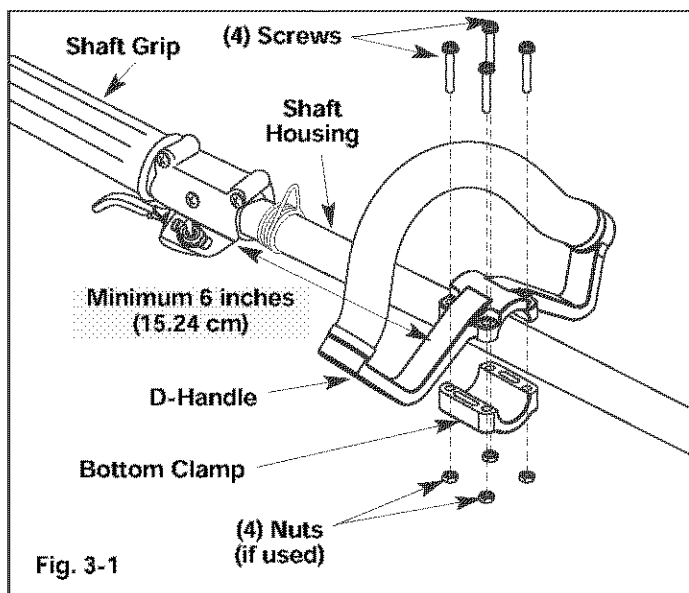
1. Remove the screws and bottom clamp piece that were installed on the D-handle for shipping.
2. Place D-handle over the shaft housing and onto the bottom clamp (Fig. 3-1). Place it a minimum of 6 inches (15.24 cm) from the end of the shaft grip.
3. Start screws with a large Flat-head or T-25 Torx screwdriver. Do not tighten until you make the handle adjustment.
4. If it was pre-installed, loosen the screws on the D-handle just enough to move the D-handle.
5. While holding the unit in the operating position (Fig. 3-2), move the D-handle to the location that provides you the best grip.
6. Tighten the clamp screws evenly, until the D-handle is secure.

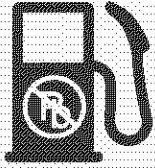

Oil and Fuel

	+	
UNLEADED GAS		2 CYCLE OIL
1 GALLON US (3.8 LITERS)		3.2 FL. OZ. (95 ml)
1 LITER		25 ml

MIXING RATIO - 40:1

Oil and Fuel Mixing Instructions

Old and/or improperly mixed fuel are the main reasons for the unit not running properly. Be sure to use fresh, clean unleaded fuel. Follow the instructions carefully for the proper fuel/oil mixture.

Definition of Blended Fuels

Today's fuels are often a blend of gasoline and oxygenates such as ethanol, methanol, or MTBE (ether). Alcohol-blended fuel absorbs water. As little as 1% water in the fuel can make fuel and oil separate. It forms acids when stored. When using alcohol-blended fuel, use fresh fuel (less than 60 days old).

Using Blended Fuels

If you choose to use a blended fuel, or its use is unavoidable, follow recommended precautions:

- Always use the fresh fuel mix explained in your operator's manual
- Always agitate the fuel mix before fueling the unit
- Drain the tank and run the engine dry before storing the unit

Using Fuel Additives

The bottle of 2-cycle oil that came with your unit contains a fuel additive which will help inhibit corrosion and minimize the formation of gum deposits. It is recommended that you use our 2-cycle oil with this unit.

If unavailable, use a good 2-cycle oil designed for air-cooled engines along with a fuel additive, such as STA-BIL® Gas Stabilizer or an equivalent. Add 0.8 oz. (23 ml.) of fuel additive per gallon of fuel according to the instructions on the container. NEVER add fuel additives directly to the unit's fuel tank.

CAUTION

For proper engine operation and maximum reliability, pay strict attention to the oil and fuel mixing instructions on the 2-cycle oil container. Using improperly mixed fuel can severely damage the engine.

Thoroughly mix the proper ratio of 2-cycle engine oil with unleaded gasoline in a separate fuel can. Use a 40:1 fuel/oil ratio. Do not mix them directly in the engine fuel tank. See the table below for specific gas and oil mixing ratios.

NOTE: One gallon (3.8 liters) of unleaded gasoline mixed with one 3.2 oz. (95 ml) bottle of 2-cycle oil makes a 40:1 fuel/oil ratio.

WARNING

Gasoline is extremely flammable. Ignited Vapors may explode. Always stop the engine and allow it to cool before filling the fuel tank. Do not smoke while filling the tank. Keep sparks and open flames at a distance from the area.

WARNING

Remove fuel cap slowly to avoid injury from fuel spray. Never operate the unit without the fuel cap securely in place.

WARNING

Add fuel in a clean, well ventilated area outdoors. Wipe up any spilled fuel immediately. Avoid creating a source of ignition for spilt fuel. Do not start the engine until fuel vapors dissipate.

NOTE: Dispose of the old fuel/oil mix in accordance to Federal, State and Local regulations.

Operation

! WARNING

Operate this unit only in a well-ventilated outdoor area. Carbon monoxide exhaust fumes can be lethal in a confined area.

! WARNING

Avoid accidental starting. Make sure you are in the starting position when pulling the starter rope (Fig. 5-3). To avoid serious injury, the operator and unit must be in a stable position while starting. Make sure that any add-on item is installed correctly and secure before starting the unit

Starting Instructions

1. Mix gas with oil. Fill fuel tank with fuel/oil mixture. See *Oil and Fuel Mixing Instructions*.
2. Make sure the On/Off Stop Control in the ON (I) position (Fig. 5-1).
3. Fully press and release the primer bulb 10 times, slowly. Some amount of **fuel should be visible in the primer bulb** and fuel lines (Fig. 5-2). If you can't see fuel in the bulb, press and release the bulb as many times as it takes before you can see fuel in it.
4. Place the choke lever in Position 1 (Start) (Fig. 5-2).
5. With the unit in the starting position (Fig. 5-3), squeeze the throttle control to the wide open (full throttle) position. Pull the starter rope briskly 5 times.
6. Place the choke lever in Position 2 (Run).
7. While squeezing the throttle control, pull the starter rope briskly 1 to 3 times to start the engine.
8. Keep the throttle squeezed and allow the engine to warm up for 15 to 30 seconds. The unit is ready for use.

IF... The engine does not start, go back to step 3.

IF... The engine fails to start after a couple attempts, place the choke lever in Position 2 and squeeze the throttle control. Pull the starter rope briskly 3 to 8 times. The engine should start. If not, repeat.

IF WARM... If the engine is already warm, make sure the On/Off Stop control is in the ON position and start the unit with the choke lever in Position 2.

Stopping Instructions

1. Release your hand from the throttle control. Allow the engine to cool down by idling.
2. Put the On/Off Stop Control in the OFF (O) position.

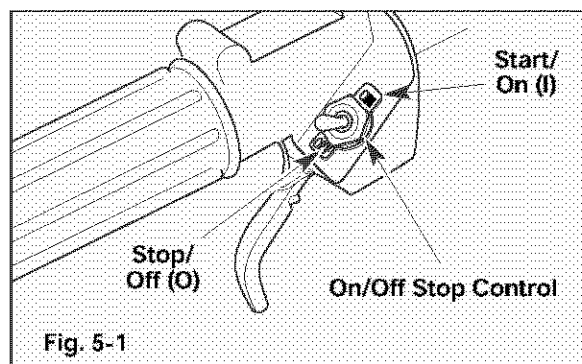

Fig. 5-1

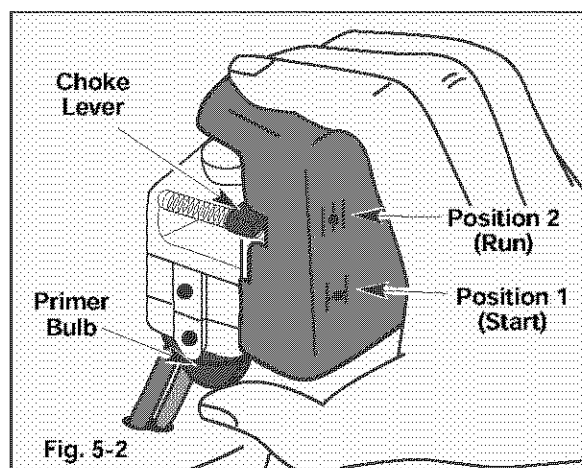

Fig. 5-2

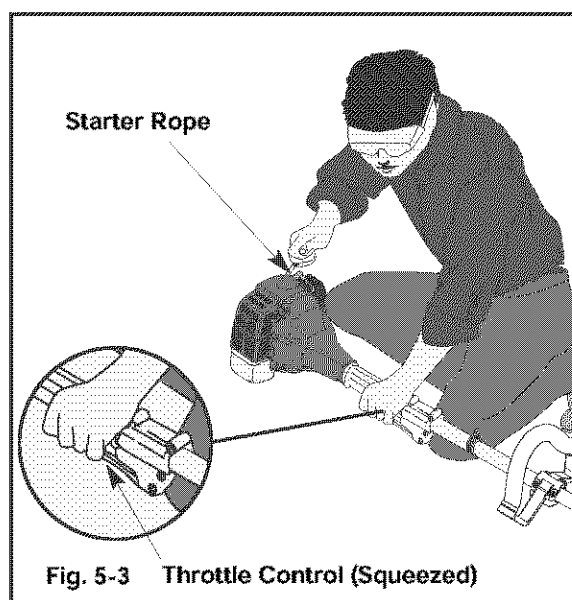
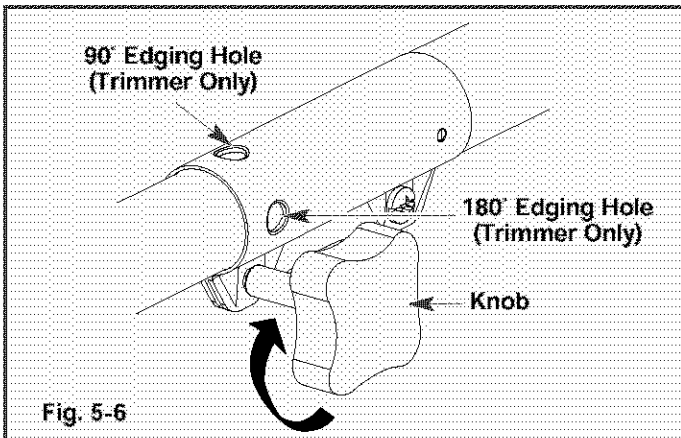
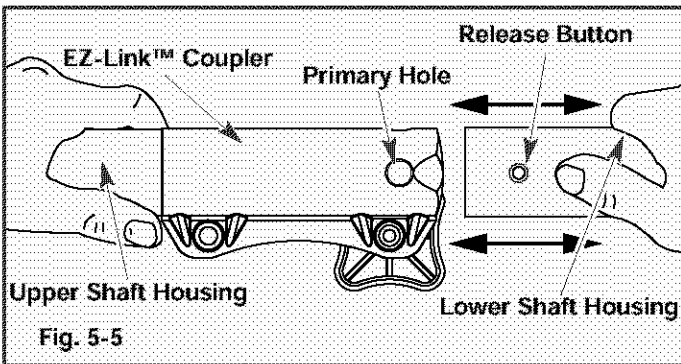
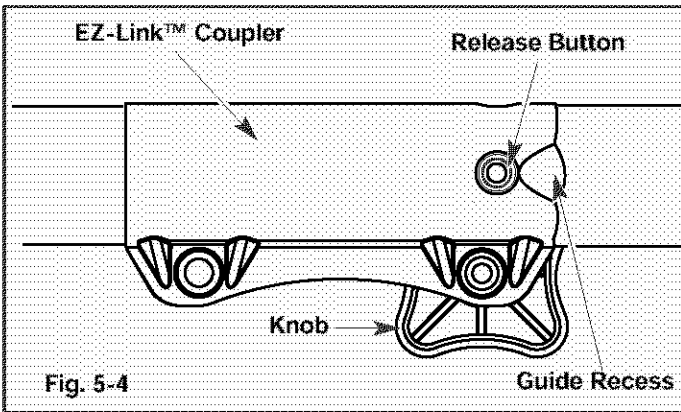

Fig. 5-3 Throttle Control (Squeezed)

Operation (continued)



Operating the EZ-Link™ System

The EZ-Link™ system enables the use of these optional Add-Ons.

Cultivator	TBGC
Edger	TBLE
Hedge Trimmer	TBAH
Straight Shaft Trimmer	TBSS
Turbo Blower	TBTB
Pole Saw	TBPS

! WARNING

Read and understand the operator's manual for each add-on prior to operation.

Removing the Cutting Attachment or Add-Ons

1. Turn the knob counterclockwise to loosen (Fig. 5-4).
2. Press and hold the release button (Fig. 5-4).
3. While firmly holding the upper shaft housing, pull the cutting attachment or add-on straight out of the EZ-Link™ coupler (Fig. 5-5).

Installing the Cutting Attachment or Add-Ons

! WARNING

To avoid serious personal injury and damage to the unit, shut unit off before removing or installing add-ons.

NOTE: To make installing or removing the add-on easier, place the unit on the ground or on a work bench.

1. Turn knob counterclockwise to loosen.
2. While firmly holding the add-on, push it straight into the EZ-Link™ coupler (Fig. 5-5).

NOTE: Aligning the release button with the guide recess will help installation (Fig. 5-4).

3. Turn the knob clockwise to tighten (Fig. 5-6).

! CAUTION

Lock the release button in the primary hole and securely tighten the knob before operating this unit.

! CAUTION

The cutting attachment and add-ons with the EZ-Link™ system are to be used in the primary hole unless stated otherwise in the specific add-ons operator's manual. Using the wrong hole could lead to personal injury, or damage to the unit.

For edging (when using the line head cutting attachment with EZ-Link™ models), lock the release button of the cutting attachment into the **90° edging hole** or the **180° edging hole** (Fig. 5-6).

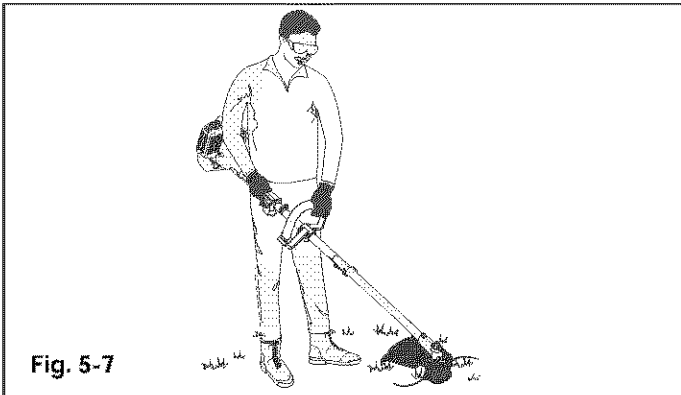

Fig. 5-7

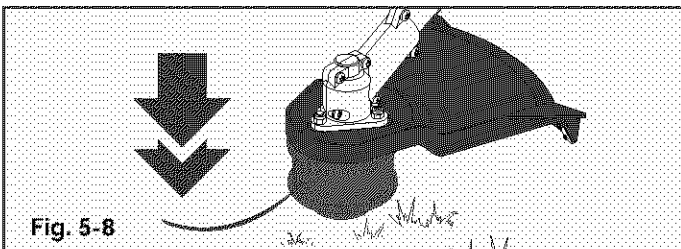

Fig. 5-8

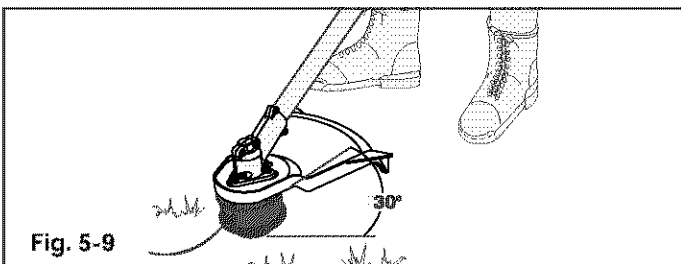

Fig. 5-9

Holding the Trimmer

! WARNING

Always wear eye, hearing, foot and body protection to reduce the risk of injury when operating this unit.

Before operating the unit, stand in the operating position (Fig. 5-7). Check for the following:

- The operator is wearing eye protection and proper clothing
- With a slightly-bent right arm, the operator's hand is holding the shaft grip
- The operator's left arm is straight, the left hand holding the D-handle
- The unit is at waist level
- The cutting attachment is parallel to the ground and easily contacts the grass without the need to bend over

Adjusting Trimming Line Length

The Bump Head cutting attachment allows you to release trimming line without stopping the engine. To release more line, lightly tap the cutting attachment on the ground (Fig. 5-8) while operating the trimmer at high speed.

NOTE: Always keep the trimming line fully extended. Line release becomes more difficult as cutting line becomes shorter.

Each time the head is bumped, about 1 inch (25.4 mm) of trimming line releases. A blade in the cutting attachment shield will cut the line to the proper length if any excess line is released.

For best results, tap the bump knob on bare ground or hard soil. If you attempt a line release in tall grass, the engine may stall. Always keep the trimming line fully extended. Line release becomes more difficult when the cutting line gets shorter.

NOTE: Do not rest the Bump Head on the ground while the unit is running.

! CAUTION

Do not remove or alter the line cutting blade assembly. Excessive line length will make the clutch overheat. This may lead to serious personal injury or damage to the unit.

Some line breakage will occur from:

- Entanglement with foreign matter
- Normal line fatigue
- Attempting to cut thick, stalky weeds
- Forcing the line into objects such as walls or fence posts

Tips for Best Trimming Results

- Keep the cutting attachment parallel to the ground.
- Do not force the cutting attachment. Allow the tip of the line to do the cutting, especially along walls. Cutting with more than the tip will reduce cutting efficiency and may overload the engine.
- Cut grass over 8 inches (200 mm) by working from top to bottom in small increments to avoid premature line wear or engine drag.
- Cut from right to left whenever possible. Cutting to the left improves the unit's cutting efficiency. Clippings are thrown away from the operator.
- Slowly move the trimmer into and out of the cutting area at the desired height. Move either in a forward-backward or side-to-side motion. Cutting shorter lengths produces the best results.
- Trim only when grass and weeds are dry.
- The life of your cutting line is dependent upon:
 - Following the trimming techniques
 - What vegetation is being cut
 - Where vegetation is cut

For example, the line will wear faster when trimming against a foundation wall as opposed to trimming around a tree.

Decorative Trimming

Decorative trimming is accomplished by removing all vegetation around trees, posts, fences and more.

Rotate the whole unit so that the cutting attachment is at a 30° angle to the ground (Fig. 5-9).

Maintenance

Maintenance Schedule

Perform these required maintenance procedures at the frequency stated in the table. These procedures should also be a part of any seasonal tune-up.

NOTE: Some maintenance procedures may require special tools or skills. If you are unsure about these procedures take your unit to any non-road engine repair establishment.

! WARNING

To prevent serious injury, never perform maintenance or repairs with unit running. Always service and repair a cool unit. Disconnect the spark plug wire to ensure that the unit cannot start.

NOTE: Maintenance, replacement or repair of the emission control devices and system may be performed by any non-road engine repair establishment, individual or authorized service dealer.

In order to assure peak performance of your engine, inspection of the engine exhaust port may be necessary after 50 hours of operation. If you notice lost RPM, poor performance or general lack of acceleration, this service may be required. If you feel your engine is in need of this inspection, refer service to any non-road engine repair establishment, individual or authorized service dealer for repair. **DO NOT** attempt to perform this process yourself as engine damage may result from contaminants involved in the cleaning process for the port.

FREQUENCY	MAINTENANCE REQUIRED	REFER TO
Before starting engine	Fill fuel tank with fresh fuel	Page 8
Every 10 hours	Clean and re-oil air filter	Page 15
Every 25 hours	Check and clean spark arrestor Check spark plug condition and gap	Page 15 Page 17
Every 50 hours	Inspect exhaust port and spark arrestor screen for clogging or obstruction to assure maximum performance levels	Page 15

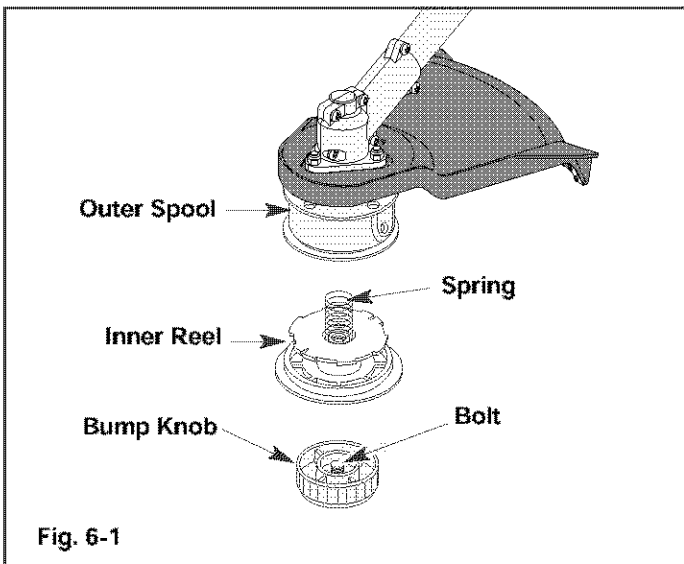

Fig. 6-1

Line Installation

This section covers both SplitLine™ and standard single line installation.

Always use original equipment manufacturer 0.105 in. (2.67 mm) replacement line. Using line other than the specified may make the engine overheat or fail.

! WARNING

Never use metal-reinforced line, wire, chain or rope. These can break off and become dangerous projectiles.

There are two methods to replace the trimming line:

- Wind the inner reel with new line
- Install a prewound inner reel

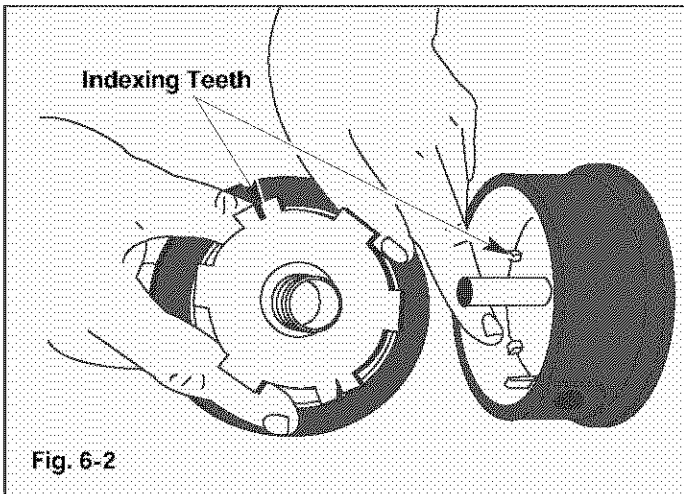

Fig. 6-2

Winding the Existing Inner Reel

1. Hold the outer spool with one hand and unscrew the Bump Knob clockwise (Fig. 6-1). Inspect the bolt inside the Bump Knob to make sure it moves freely. Replace the Bump Knob if damaged.
2. Remove the inner reel from the outer spool (Fig. 6-1).
3. Remove spring from the inner reel (Fig. 6-1).
4. Use a clean cloth to clean the the inner reel, spring, shaft, and inner surface of the outer spool.
5. Check the indexing teeth on the inner reel and outer spool for wear (Fig. 6-2). If necessary, remove burrs or replace the reel and spool.

NOTE: *SplitLine™ can only be used with the inner reel with the slotted holes. Single line can be used on either type of inner reel. Use figure 6-3 to identify the inner reel you have.*

NOTE: *Always use the correct line length when installing trimming line on the unit. The line may not release properly if the line is too long.*

Single Line Installation

Go To Step 8 for *SplitLine™* Installation

6. Take approximately 20 feet (6 m) of new trimming line, loop it into two equal lengths. Insert each end of the line through one of the two holes in the inner reel (Fig. 6-4). Pull the line through the inner reel so that the loop is as small as possible.
7. Wind the lines in tight even layers, onto the reel (Fig. 6-5). Wind the line in the direction indicated on the inner reel. Place your index finger between the two lines to stop the lines from overlapping. Do not overlap the ends of the line. Proceed to step 11.

SplitLine™ Installation

8. Take approximately 10 feet (3 m) of new trimming line. Insert one end of the line through one of the two holes in the inner reel (Fig. 6-6). Pull the line through the inner reel until only about 4 inches is left out.
9. Insert the end of the line into the open hole in the inner reel and pull the line tight to make the loop as small as possible (Fig. 6-6).
10. Before winding, split the line back about 6 inches.
11. Wind the line in tight even layers in the direction indicated on the inner reel.

NOTE: *Failure to wind the line in the direction indicated will cause the cutting attachment to operate incorrectly.*

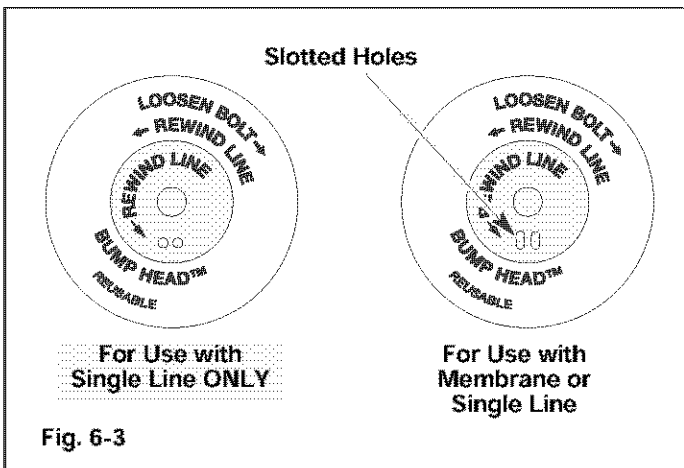

Fig. 6-3

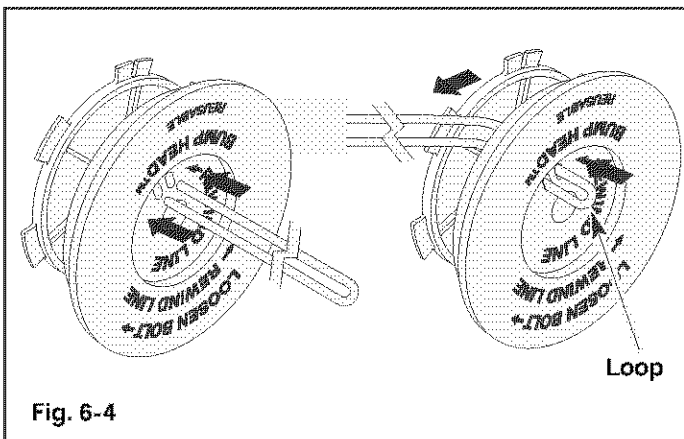
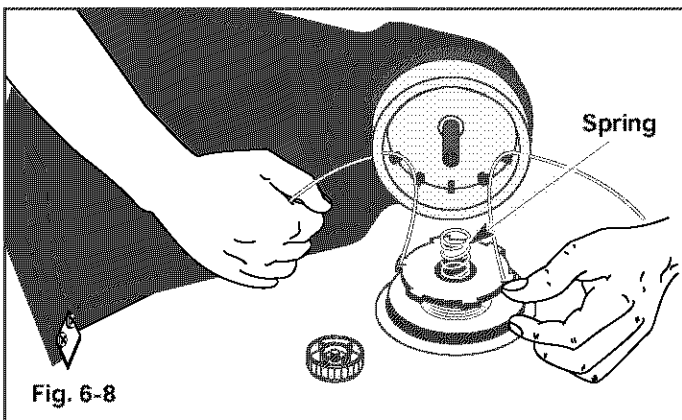
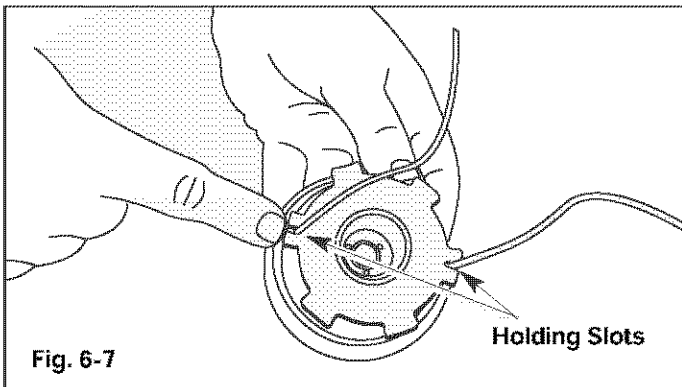
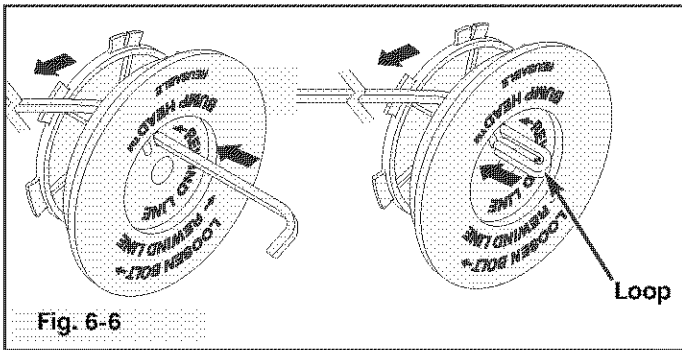
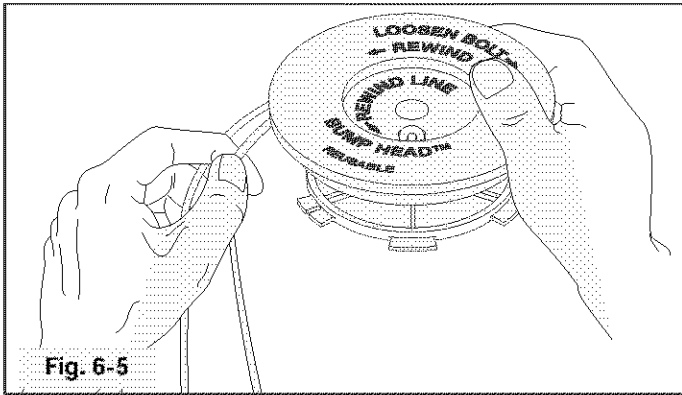

Fig. 6-4

Maintenance (continued)



12. Insert the ends of the line into the two holding slots (Fig. 6-7).
13. Insert the ends of the line through the eyelets in the outer spool and place inner reel with spring inside the outer spool (Fig. 6-8). Push the inner reel and outer spool together. While holding the inner reel and outer spool, grasp the ends and pull firmly to release the line from the holding slots in the reel.

NOTE: The spring must be assembled on the inner reel before reassembling the cutting attachment.

14. Hold the inner reel in place and install the Bump Knob by turning counterclockwise. Tighten securely.

Installing a Pre Wound Reel

1. Hold the outer spool with one hand and unscrew the Bump Knob clockwise (Fig. 6-1). Inspect the bolt inside the Bump Knob to make sure it moves freely. Replace the Bump Knob if damaged.
2. Remove the old inner reel from the outer spool (Fig. 6-1).
3. Remove the spring from the old inner reel (Fig. 6-1).
4. Place the spring in the new inner reel.

NOTE: The spring must be assembled on the inner reel before reassembling the cutting attachment.

5. Insert the ends of the line through the eyelets in the outer spool (Fig. 6-8).
6. Place the new inner reel inside the outer spool. Push the inner reel and outer spool together. While holding the inner reel and outer spool, grasp the ends and pull firmly to release the line in the spool.
7. Hold the inner reel in place and install the Bump Knob by turning counterclockwise. Tighten securely.

Replacement Parts

For replacement parts, refer to the *Accessories / Replacement Parts* section.

Air Filter Maintenance

Cleaning the Air Filter

! WARNING

To avoid serious personal injury, always turn your trimmer off and allow it to cool before you clean or service it.

Clean and re-oil the air filter every 10 hours of operation. It is an important item to maintain. Failure to maintain the air filter will **VOID** the warranty.

1. Remove the carburetor/air filter cover by pushing on the tab on top of the cover (Fig. 6-9).
2. Remove the air filter (Fig. 6-10).
3. Wash the filter in detergent and water. Rinse the filter thoroughly and allow it to dry.
4. Apply enough clean SAE 30 motor oil to lightly coat the filter (Fig. 6-11).
5. Squeeze the filter to spread and remove excess oil (Fig. 6-11).
6. Reinstall the filter (Fig. 6-10) and air filter cover (Fig. 6-9).

NOTE: If the unit is operated without the air filter, you will **VOID** the warranty.

Spark Arrestor Maintenance

! WARNING

To avoid serious personal injury, always turn your trimmer off and allow it to cool before you clean or service it.

1. Turn the powerhead so the back of the engine is facing forward. In this position, the starter rope is to the left (Fig. 6-12).

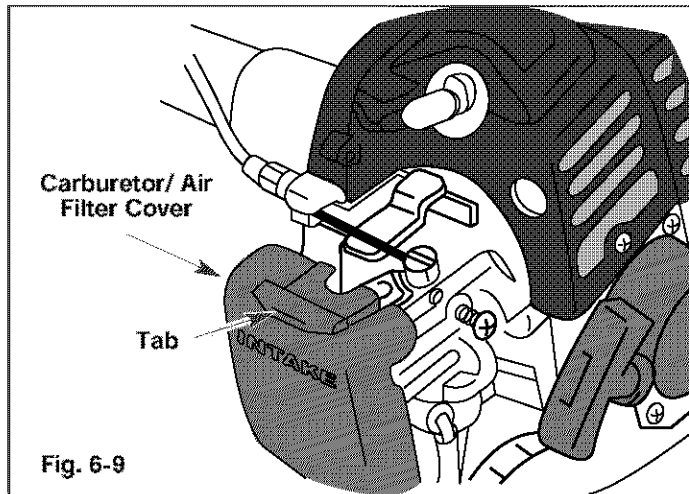

Fig. 6-9

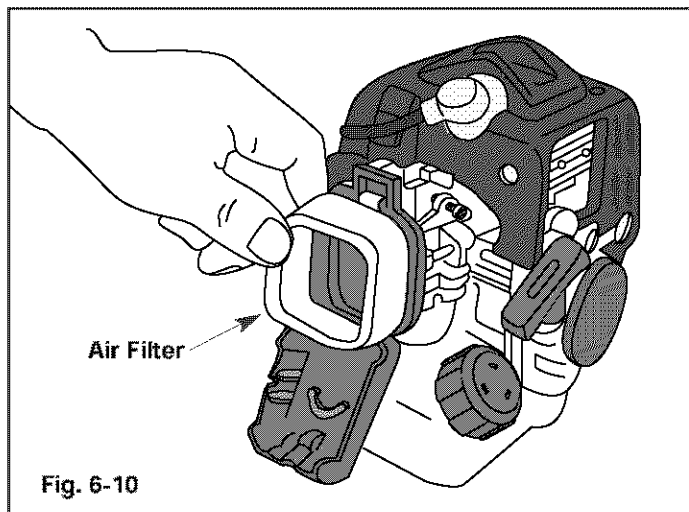

Fig. 6-10

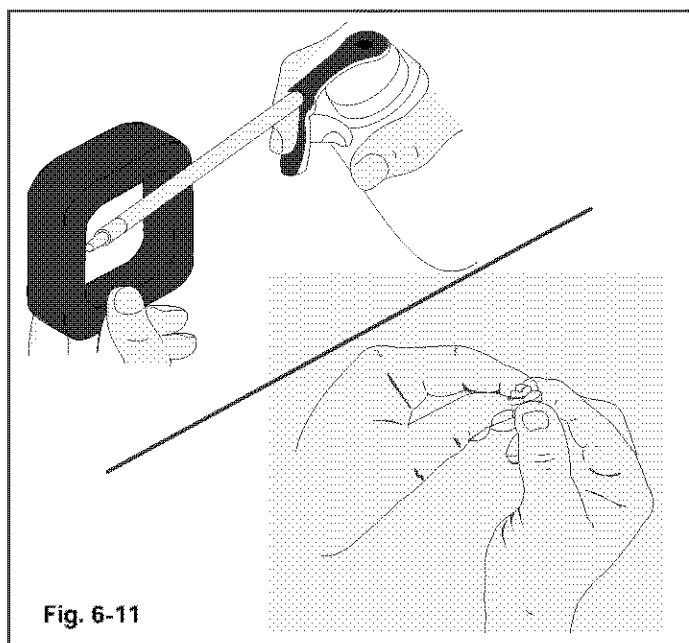

Fig. 6-11

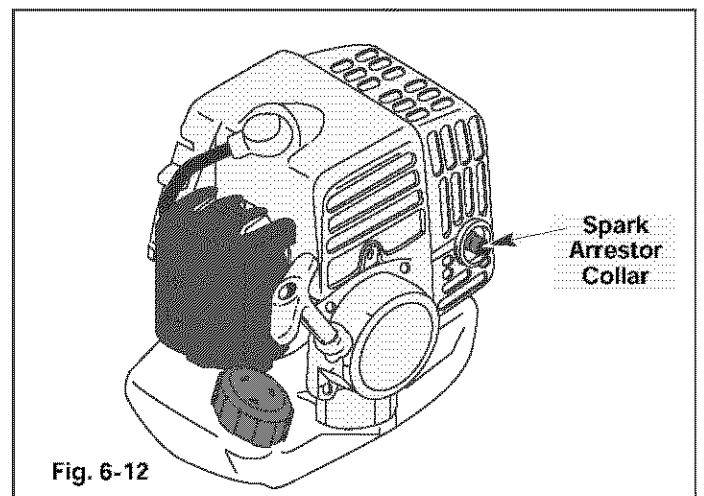

Fig. 6-12

Maintenance (continued)

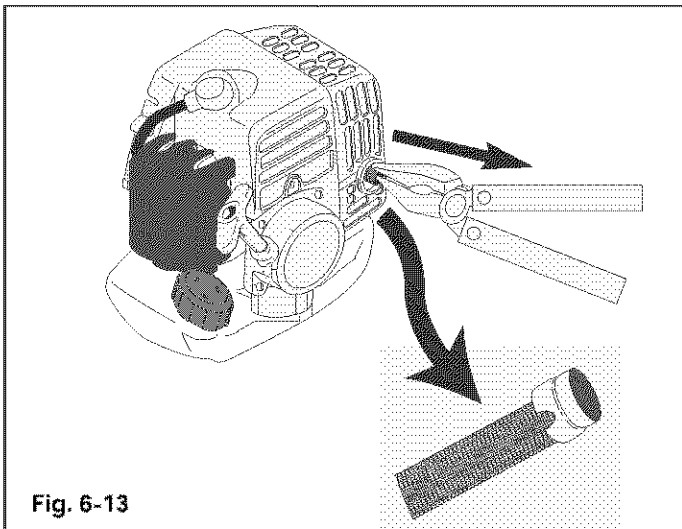

Fig. 6-13

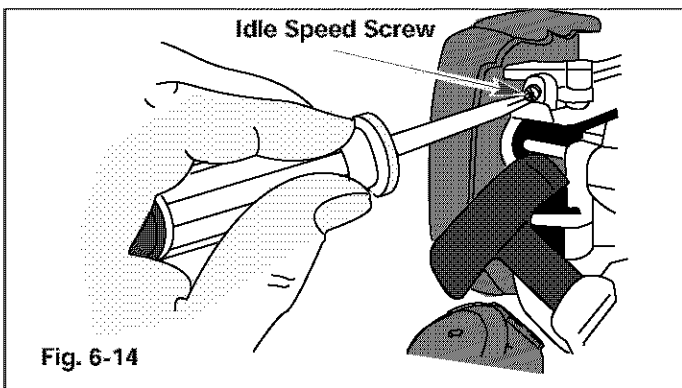

Fig. 6-14

2. Use a needle-nose pliers to grasp the collar of the spark arrester and pull it out of the muffler (Fig. 6-13).

NOTE: Use only a needle-nose pliers. Other pliers or tools may damage the spark arrester.

3. Clean the spark arrester with a wire brush. Replace it if it is damaged or if you are unable to clean it thoroughly.
4. Reinstall spark arrester. Use the needle-nose pliers to gently push the spark arrester back into the muffler until it snaps into place.

Carburetor Adjustment

The idle speed of the engine is adjustable by the screw next to the air filter cover (Fig. 6-14).

NOTE: Careless adjustments can seriously damage your unit. An authorized service dealer should make carburetor adjustments.

Check Fuel Mixture

Old and/or improperly mixed fuel is usually the reason for improper unit performance. Drain and refill the tank with fresh, properly mixed fuel prior to making any adjustments. Refer to *Oil and Fuel Information*.

Clean Air Filter

The condition of the air filter is important to the operation of the unit. A dirty air filter will restrict air flow and change the air/fuel mixture. This is often mistaken for an out of adjustment carburetor. Check the condition of the air filter before adjusting the idle speed screw. Refer to *Air Filter Maintenance*.

Adjust Idle Speed Screw

! WARNING

The cutting attachment may be spinning during idle speed adjustment. Wear protective clothing and observe all safety instructions to prevent serious personal injury.

If, after checking the fuel mixture and cleaning the air filter, the engine still will not idle, adjust the idle speed screw as follows:

1. Start the engine and let it run at a high idle for a minute to warm up.
2. Release the throttle trigger and let the engine idle. If the engine stops, insert a small phillips or flat blade screwdriver into the screw next to the air filter cover (Fig. 6-14). Turn the idle speed screw in, clockwise, 1/8 of a turn at a time (as needed) until the engine idles smoothly.

NOTE: The cutting attachment should not rotate when the engine idles.

3. If the cutting attachment rotates when the engine idles, turn the idle speed screw counterclockwise 1/8 of a turn at a time (as needed), to reduce idle speed.

Checking the fuel mixture, cleaning the air filter, and adjusting the idle speed screw should solve most engine problems. If not and all the following are true:

- The engine will not idle
- The engine hesitates or stalls on acceleration
- There is a loss of engine power

Have the carburetor adjusted by an authorized service dealer.

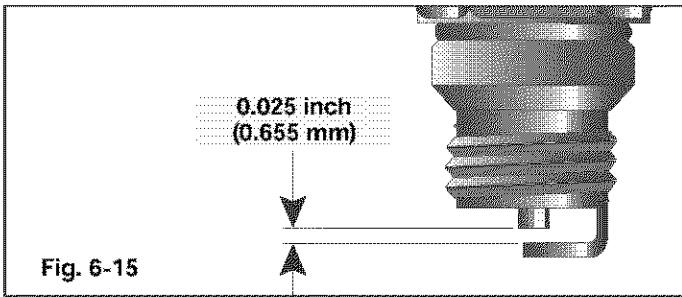

Replacing the Spark Plug

Use a Champion RCJ6Y spark plug (or equivalent). The correct air gap is **0.025 inch (0.655 mm)**. Remove the plug after every 25 hours of operation and check its condition.

1. Stop the engine and allow it to cool. Grasp the plug wire firmly and pull the cap from the spark plug.
2. Clean dirt from around the spark plug. Remove the spark plug from the cylinder head by turning a 5/8 inch socket counterclockwise.
3. Replace cracked, fouled or dirty spark plug. Set the air gap at 0.025 inch (0.655 mm) using a feeler gauge (Fig. 6-15).

CAUTION

Do not sand blast, scrape, or clean electrodes. Grit in the engine could damage the cylinder.

4. Install a correctly-gapped spark plug in the cylinder head. Tighten by turning the 5/8 inch socket clockwise until snug.

If using a torque wrench torque to:

110-120 in.·lb. (12.3-13.5 N·m).

Do not over tighten.

Cleaning

WARNING

To avoid serious personal injury, always turn your trimmer off and allow it to cool before you clean or do any maintenance on it.

Use a small brush to clean off the outside of the unit. Do not use strong detergents. Household cleaners that contain aromatic oils such as pine and lemon, and solvents such as kerosene, can damage plastic housing or handle. Wipe off any moisture with a soft cloth.

Storage

- Never store the unit with fuel in the tank where fumes may reach an open flame or spark.
- Allow the engine to cool before storing.
- Store the unit locked up to prevent unauthorized use or damage.
- Store the unit in a dry, well-ventilated area.
- Store the unit out of the reach of children.

Long Term Storage

If the unit will be stored for an extended time, use the following storage procedure:

1. Drain all fuel from the fuel tank into a container with the same 2-cycle fuel mixture. Do not use fuel that has been stored for more than 60 days. Dispose of the old fuel/oil mix in accordance to Federal, State and Local regulations.
2. Start the engine and allow it to run until it stalls. This ensures that all fuel has been drained from the carburetor.
3. Allow the engine to cool. Remove the spark plug and put 1 oz. (30 ml) of any high quality motor oil or 2-cycle oil into the cylinder. Pull the starter rope slowly to distribute the oil. Reinstall the spark plug.

NOTE: Remove the spark plug and drain all of the oil from the cylinder before attempting to start the trimmer after storage.

4. Thoroughly clean the unit and inspect it for any loose or damaged parts. Repair or replace damaged parts and tighten loose screws, nuts or bolts. The unit is ready for storage.

Transporting

- Allow the engine to cool before transporting.
- Drain fuel from unit.
- Tighten fuel cap before transporting.
- Secure the unit while transporting.

Accessories / Replacement Parts

2-Cycle Oil	180965
Spark Plug	181765
Spark Arrestor	181696
Replacement Line Cartridge	753-1160
Inner Reel Spring	610636
Bump Head Knob Assembly	180814
Brushcutter Accessory Kit	41AM079G100
Fuel Cap	181612
Shoulder Strap	682075

Section 7

Troubleshooting

ENGINE WILL NOT START

CAUSE

On/Off stop control is in the OFF position
Empty fuel tank
Primer bulb wasn't pressed enough
Engine is flooded

Old or improperly mixed fuel
Fouled spark plug
Plugged spark arrestor

ACTION

Turn the on/off stop control to ON
Fill fuel tank with properly mixed fuel
Press primer bulb fully and slowly 10 times
Squeeze the trigger, put lever in Position 2 and pull the starter rope
Drain gas tank and add fresh fuel mixture
Replace or clean the spark plug
Clean or replace spark arrestor

ENGINE WILL NOT IDLE

CAUSE

Air filter is plugged
Old or improperly mixed fuel
Improper carburetor adjustment

ACTION

Replace or clean the air filter
Drain gas tank and add fresh fuel mixture
Adjust according to the *Carburetor Adjustments* section

ENGINE WILL NOT ACCELERATE

CAUSE

Old or improperly mixed fuel
Improper carburetor adjustment
Cutting attachment bound with grass
Dirty air filter
Plugged spark arrestor

ACTION

Drain gas tank and add fresh fuel mixture
Take to an authorized service dealer for an adjustment
Stop the engine and clean the cutting attachment
Clean or replace the air filter
Clean or replace spark arrestor

ENGINE LACKS POWER OR STALLS WHEN CUTTING

CAUSE

Old or improperly mixed fuel
Improper carburetor adjustment
Fouled spark plug
Plugged spark arrestor

ACTION

Drain gas tank and add fresh fuel mixture
Take to an authorized service dealer for an adjustment
Replace or clean the spark plug
Clean or replace spark arrestor

CUTTING ATTACHMENT WILL NOT ADVANCE LINE

CAUSE

Cutting attachment bound with grass
Cutting attachment out of line
Inner reel bound up
Cutting head dirty
Line welded
Line twisted when refilled
Not enough line is exposed

ACTION

Stop the engine and clean cutting attachment
Refill with new line
Replace the inner reel
Clean inner reel and outer spool
Disassemble, remove the welded section and rewind
Disassemble and rewind the line
Push the bump knob and pull out line until 4 inches (102 mm) of line is outside of the cutting attachment

CUTTING LINE ADVANCES UNCONTROLLABLY

CAUSE

Oil, cleaner or lubricant in cutting head

ACTION

Clean and thoroughly dry the cutting head

If further assistance is required, contact your authorized service dealer.

Specifications

ENGINE*

Engine Type.....	Air-Cooled, 2-Cycle
Stroke.....	1.25 in. (31.75 mm)
Displacement.....	1.4 cu in. (25 cc)
Clutch Type.....	Centrifugal
Idle Speed RPM.....	2,400 - 3,600 rpm
Operating RPM.....	7,000+ rpm
Ignition Type.....	Electronic
Ignition Switch.....	Toggle Switch
Spark Plug Gap.....	0.025 in. (0.655 mm)
Lubrication.....	Fuel/Oil Mixture
Fuel/Oil Ratio.....	40:1
Carburetor.....	Diaphragm, All-Position
Starter.....	Auto Rewind
Muffler.....	Baffled with Guard
Throttle.....	Manual Spring Return
Fuel Tank Capacity.....	20 oz. (591 ml)

DRIVE SHAFT & CUTTING ATTACHMENT*

Drive Shaft Housing.....	(EZ-Link) Aluminum Tube
Throttle Control.....	Finger-Tip Trigger
Approximate Unit Weight (No fuel, with cutting attachment, shield and D-handle).....	11 lbs. (5 kg)
Cutting Mechanism.....	Dual String Cutting Head
Line Spool.....	Bump Line Releaser
Line Spool Diameter.....	4 inches (101.6 mm)
Trimming Line Diameter.....	0.105 inches (2.67 mm)
Cutting Path Diameter.....	18 inches (44 cm)

*All specifications are based on the latest product information available at the time of printing. We reserve the right to make changes at any time without notice.

Notes

Notes

Notes

EPA Emission Control Warranty Statement

Your Warranty Rights and Obligations

The Environmental Protection Agency and Cub Cadet LLC (Cub Cadet) are pleased to explain the emission control system warranty on your 2002 and later small off-road engine. New small off-road engines must be designed, built and equipped to meet stringent anti-smog standards. Cub Cadet must warrant the emission control system on your small off-road engine for the periods of time listed below provided there has been no abuse, neglect or improper maintenance of your small off-road engine.

Your emission control system may include parts such as the carburetor or fuel-injected system, the ignition system, and catalytic converter. Also included may be hoses, belts, connectors and other emission-related assemblies.

Where a warrantable condition exists, Cub Cadet will repair your small off-road engine at no cost to you including diagnosis, parts and labor.

The 2002 and later small off-road engines are warranted for two years. If any emission-related part on your engine is defective, the part will be repaired or replaced by Cub Cadet.

Owners Warranty Responsibilities

- As the small off-road engine owner, you are responsible for the performance of the required maintenance listed in your operator's manual. Cub Cadet recommends that you retain all receipts covering maintenance on your small off-road engine, but Cub Cadet cannot deny warranty solely for the lack of receipts or for your failure to ensure the performance of all scheduled maintenance.
- As the small off-road engine owner, you however should be aware that Cub Cadet may deny you warranty coverage if your small off-road engine or a part has failed due to abuse, neglect, improper maintenance or unapproved modifications.
- You are responsible for presenting your small off-road engine to a Cub Cadet Authorized Service Center as soon as a problem exists. The warranty repairs should be completed in a reasonable amount of time, not to exceed 30 days.

If you have any questions regarding your warranty rights and responsibilities, you should call 1-877-282-8684.

Manufacturer's Warranty Coverage

- The warranty period begins on the date the engine or equipment is delivered to the retail purchaser.
- The manufacturer warrants to the initial owner and each subsequent purchaser, that the engine is free from defects in material and workmanship which cause the failure of a warranted part for a period of two years.
- Repair or replacement of warranted part will be performed at no charge to the owner at an Authorized Cub Cadet Service Center. For the nearest location please contact Cub Cadet at: 1-877-282-8684.
- Any warranted part which is not scheduled for replacement, as required maintenance or which is scheduled for only for regular inspection to the effect of "Repair or Replace as Necessary" is warranted for the warranty period. Any warranted part which is scheduled for replacement as required maintenance will be warranted for the period of time up to the first scheduled replacement point for that part.
- The owner will not be charged for diagnostic labor which leads to the determination that a warranted part is defective, if the diagnostic work is performed at an Authorized Cub Cadet Service Center.
- The manufacturer is liable for damages to other engine components caused by the failure of a warranted part still under warranty.
- Failures caused by abuse, neglect or improper maintenance are not covered under warranty.
- The use of add-on or modified parts can be grounds for disallowing a warranty claim. The manufacturer is not liable to cover failures of warranted parts caused by the use of add-on or modified parts.
- In order to file a claim, go to your nearest Authorized Cub Cadet Service Center. Warranty services or repairs will be provided at all Authorized Cub Cadet Service Centers.
- Any manufacturer approved replacement part may be used in the performance of any warranty maintenance or repair of emission related parts and will be provided without charge to the owner. Any replacement part that is equivalent in performance or durability may be used in non-warranty maintenance or repair and will not reduce the warranty obligations of the manufacturer
- The following components are included in the emission related warranty of the engine, air filter, carburetor, primer, fuel lines, fuel pick up/ fuel filter, ignition module, spark plug and muffler.

ENGINE PARTS - MODEL CC3075

2-CYCLE GAS TRIMMER

PPN 41ADC75C010

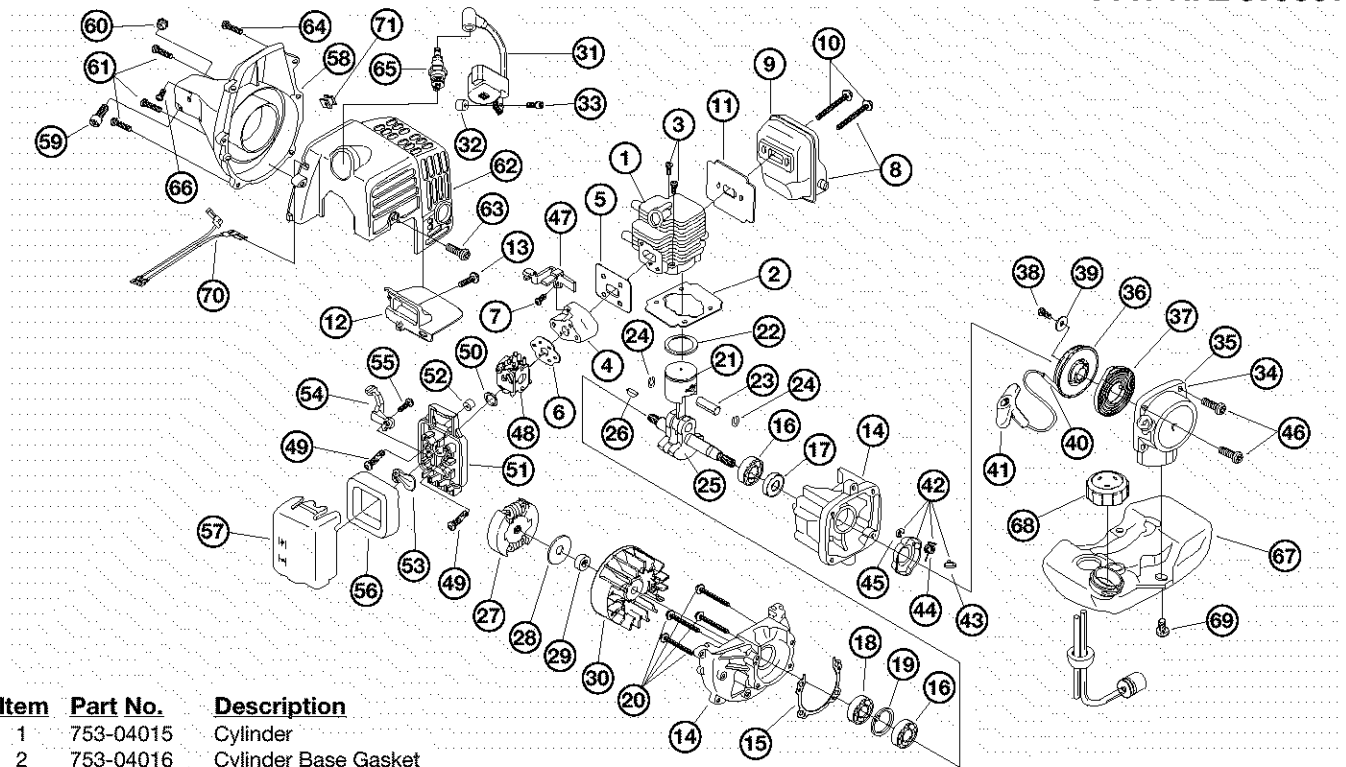

Item	Part No.	Description
1	753-04015	Cylinder
2	753-04016	Cylinder Base Gasket
3	791-181706	Bolt
4	791-181707	Insulator
5	791-181708	Insulator Gasket
6	791-181709	Carburetor Gasket
7	791-181710	Screw and Washer
8	753-1176	Muffler Assembly (includes 9 & 10)
9	753-1177	Muffler
10	791-181713	Screw
11	791-181714	Muffler Gasket
12	791-181715	Muffler Plate
13	791-181716	Screw
14	791-181717	Crankcase Service Assembly (includes 15-20 & 25)
15	791-181718	Crankcase Gasket
16	791-181719	Bearing
17	791-181720	Oil Seal
18	791-181721	Oil Seal
19	791-181722	Snap Ring
20	791-181723	Screw
21	753-04018	Piston
22	791-182014	Ring
23	791-182015	Piston Pin
24	791-181727	Snap Ring
25	753-04019	Crankshaft
26	791-181729	Key
27	791-181730	Clutch
28	791-181074	Clutch Washer
29	791-181731	Spacer
30	791-181732	Flywheel Assembly
31	791-181733	Module Assembly (includes 32 & 33)
32	791-181734	Spacer
33	753-1181	Screw
34	791-181777	Recoil Assembly (includes 35-41)
35	791-181737	Recoil Case
36	791-181738	Recoil Pulley
37	791-181739	Recoil Spring
38	791-181740	Screw
39	791-181741	Washer
40	791-181742	Rope

Item	Part No.	Description
41	791-181079	Pull Handle
42	791-182118	Pulley Assembly (includes 43-45)
43	791-181745	Ratchet
44	791-181746	Spring
45	791-181747	Retaining Ring
46	791-181716	Screw
47	791-181748	Throttle Bracket
48	753-04389	Carburetor (includes Primer Bulb)
49	791-181750	Screw
50	791-181751	O-Ring
51	791-181752	Air Cleaner Assembly (includes 52-57)
52	791-181753	Sleeve
53	791-181754	Choke Plate
54	791-181755	Choke Lever
55	791-181756	Screw
56	791-181757	Air Filter
57	791-181758	Air Cleaner Cover
58	753-1178	Clutch Housing Assembly
59	791-181760	Bolt
60	791-181761	Nut
61	791-181762	Screw
62	753-1179	Engine Cover
63	791-181716	Screw
64	791-181762	Screw
65	791-181765	Spark Plug
66	791-182188	Screw
67	791-181766	Fuel Tank (68-69 includes fuel lines)
68	791-182612	Fuel Cap Assembly
69	791-181768	Screw
70	791-181769	Lead Wire Assembly
71	791-182157	Grommet
*	791-181696	Spark Arrestor
*	791-181701	Primer Bulb
*	791-181702	Carburetor Repair Kit
*	791-181703	Gasket/Diaphragm Repair Kit
*		not shown

BOOM AND TRIMMER PARTS - CC3075

2-CYCLE GAS TRIMMER

PPN 41ADC75C010

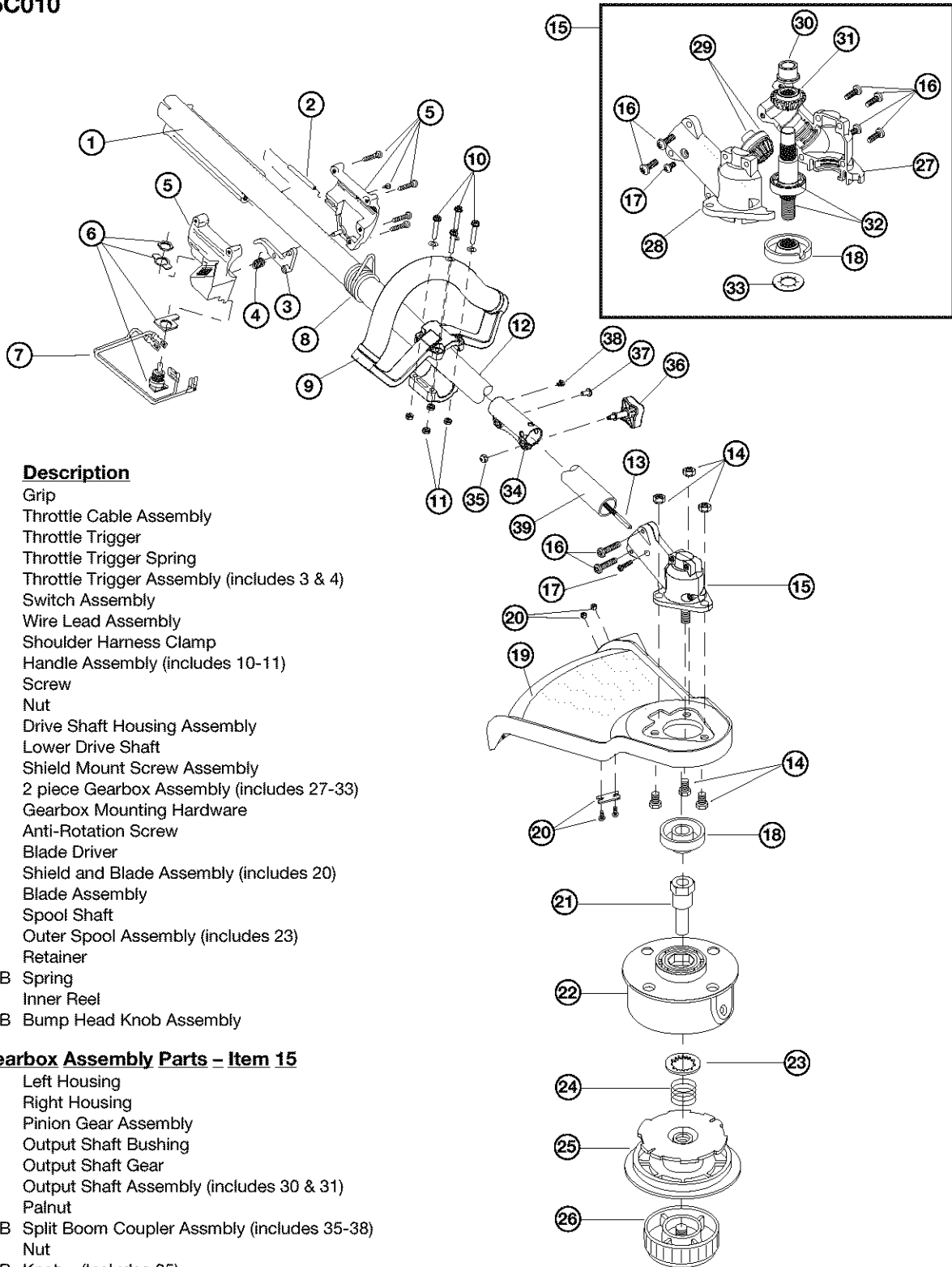

Item	Part No.	Description
1	791-180866	Grip
2	791-181688	Throttle Cable Assembly
3	791-180975	Throttle Trigger
4	791-610314	Throttle Trigger Spring
5	791-181689	Throttle Trigger Assembly (includes 3 & 4)
6	791-180252	Switch Assembly
7	791-181690	Wire Lead Assembly
8	791-610327	Shoulder Harness Clamp
9	753-1151	Handle Assembly (includes 10-11)
10	753-1152	Screw
11	753-1154	Nut
12	753-04503	Drive Shaft Housing Assembly
13	791-181570	Lower Drive Shaft
14	791-182200	Shield Mount Screw Assembly
15	791-182193	2 piece Gearbox Assembly (includes 27-33)
16	791-182195	Gearbox Mounting Hardware
17	791-145569	Anti-Rotation Screw
18	791-182196	Blade Driver
19	753-1158	Shield and Blade Assembly (includes 20)
20	791-682061	Blade Assembly
21	791-612483	Spool Shaft
22	791-683301	Outer Spool Assembly (includes 23)
23	791-612026	Retainer
24	791-610636B	Spring
25	791-147495	Inner Reel
26	791-180814B	Bump Head Knob Assembly
2 Piece Gearbox Assembly Parts - Item 15		
27	791-182191	Left Housing
28	791-182192	Right Housing
29	791-182194	Pinion Gear Assembly
30	791-182199	Output Shaft Bushing
31	791-182198	Output Shaft Gear
32	791-182197	Output Shaft Assembly (includes 30 & 31)
33	753-04348	Palnut
34	791-181616B	Split Boom Coupler Assmby (includes 35-38)
35	791-181886	Nut
36	791-181618B	Knob (Includes 35)

Optional Accessories

- * 753-1160 Reel and Line Assembly
- * 41AM079G100 Brush Cutter Accessory Kit
- * 753-1161 Bump Head Assembly (includes 21-26)
- * 682075B Shoulder Harness

* Items Not Shown

MANUFACTURER'S LIMITED WARRANTY FOR:

Cub Cadet

The limited warranty set forth below is given by Cub Cadet LLC with respect to new merchandise purchased and used in the United States, its possessions and territories.

Cub Cadet LLC warrants this product against defects in material and workmanship for a period of two (2) years commencing on the date of original purchase and will, at its option, repair or replace, free of charge, any part found to be defective in material or workmanship. This limited warranty shall only apply if this product has been operated and maintained in accordance with the Operator's Manual furnished with the product, and has not been subject to misuse, abuse, commercial use, neglect, accident, improper maintenance, alteration, vandalism, theft, fire, water or damage because of other peril or natural disaster. Damage resulting from the installation or use of any accessory or attachment not approved by Cub Cadet LLC for use with the product(s) covered by this manual will void your warranty as to any resulting damage. This warranty is limited to ninety (90) days from the date of original retail purchase for any Cub Cadet product that is used for rental or commercial purposes, or any other income-producing purpose.

HOW TO OBTAIN SERVICE: Warranty service is available, WITH PROOF OF PURCHASE THROUGH YOUR LOCAL AUTHORIZED SERVICE DEALER. To locate the dealer in your area, visit our website at www.cubcadet.com, check for a listing in the Yellow Pages, call **1-877-282-8684** or write to P.O. Box 361131, Cleveland, OH 44136-0019.

This limited warranty does not provide coverage in the following cases:

- A. Tune-ups - Spark Plugs, Carburetor Adjustments, Filters
- B. Wear items - Bump Knobs, Outer Spools, Cutting Line, Inner Reels, Starter Pulley, Starter Ropes, Drive Belts
- C. Cub Cadet LLC does not extend any warranty for products sold or exported outside of the United States of America, its possessions and territories, except those sold through Cub Cadet's authorized channels of export distribution.

Cub Cadet LLC reserves the right to change or improve the design of any Cub Cadet Product without assuming any obligation to modify any product previously manufactured.

No implied warranty, including any implied warranty of merchantability or fitness for a particular purpose, applies after the applicable period of express written warranty above as to the parts as identified. No other express warranty or guaranty, whether written or oral, except as mentioned above, given by any person or entity, including a dealer or retailer, with respect to any product shall bind Cub Cadet LLC. During the period of the Warranty, the exclusive remedy is repair or replacement of the product as set forth above. (Some states do not allow limitations on how long an implied warranty lasts, so the above limitation may not apply to you.)

The provisions as set forth in this Warranty provide the sole and exclusive remedy arising from the sales. Cub Cadet LLC shall not be liable for incidental or consequential loss or damages including, without limitation, expenses incurred for substitute or replacement lawn care services, for transportation or for related expenses, or for rental expenses to temporarily replace a warranted product. (Some states do not allow limitations on how long an implied warranty lasts, so the above limitation may not apply to you.)

In no event shall recovery of any kind be greater than the amount of the purchase price of the product sold. Alteration of the safety features of the product shall void this Warranty. You assume the risk and liability for loss, damage, or injury to you and your property and/or to others and their property arising out of the use or misuse or inability to use the product.

This limited warranty shall not extend to anyone other than the original purchaser, original lessee or the person for whom it was purchased as a gift.

How State Law Relates to this Warranty: This warranty gives you specific legal rights, and you may also have other rights which vary from state to state.

To locate your nearest service dealer dial **1-877-282-8684**.

Cub Cadet LLC

P.O. Box 361131

Cleveland, OH 44136-0019