

Cub Cadet

Operator's Manual

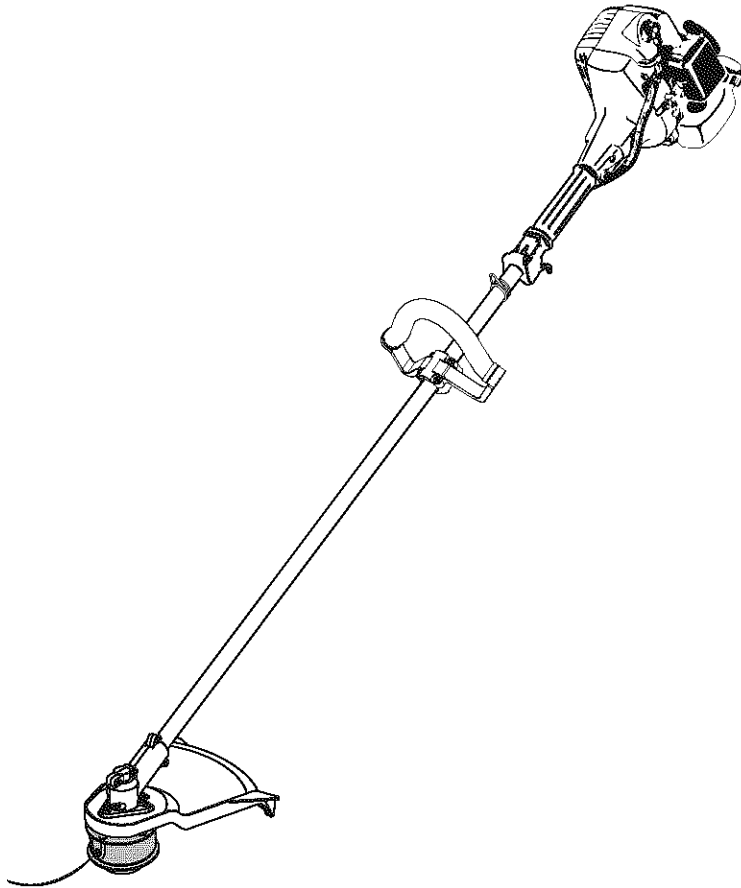

2-Cycle Trimmer
Model CC 3000

IMPORTANT: READ SAFETY RULES AND INSTRUCTIONS CAREFULLY

Warning: For users on U.S. Forest Land and in the states of California, Maine, Oregon and Washington. All U.S. Forest Land and the state of California (Public Resources Codes 4442 and 4443), Oregon and Washington require, by law that certain internal combustion engines operated on forest brush and/or grass-covered areas be equipped with a spark arrestor, maintained in effective working order, or the engine be constructed, equipped and maintained for the prevention of fire. Check with your state or local authorities for regulations pertaining to these requirements. Failure to follow these requirements could subject you to liability or a fine. This unit is factory equipped with a spark arrestor. If it requires replacement, ask your Cub Cadet dealer dealer to install the Accessory Part #791-181696 Spark Arrestor Kit or contact the service department.

Cub Cadet LLC P.O. Box 361131 Cleveland, OH 44136-0019

FORM 769-00023 (11/01) (10700 rev. P00)
Printed in U.S.A.

TABLE OF CONTENTS

Content	Page
Section 1: Safety	3
Section 2: Know Your Unit	7
Section 3: Assembly	8
Section 4: Oil and Fuel	9
Section 5: Operation	10
Section 6: Maintenance	12
Section 7: Troubleshooting	18
Section 8: Specifications	19
Section 9: Warranty	20

TO THE OWNER

Thank you for buying this quality product. This modern outdoor power tool will provide many hours of useful service. You will find it to be a great labor-saving device. This operator's manual provides you with easy-to-understand operating instructions. Before starting or operating this equipment, read the whole manual and follow all the instructions to keep your new outdoor power tool in top operating condition.

All information, illustrations and specifications in this manual are based on the latest product information available at the time of printing. We reserve the right to make changes at any time without notice. Service on this unit both within and after the warranty period should be performed only by a Cub Cadet dealer. Proof of purchase will be required for warranty service.

FINDING MODEL NUMBER

Before you start assembling your new equipment, please locate the model plate on the equipment and copy the information from it in the space provided below. This information is important if you need help from your Cub Cadet dealer.

- You can locate the model number on the shaft housing of the unit next to the On/Off Stop Control Switch. A sample model plate is explained below. For future reference, please copy the model number and the serial number of the equipment in the space below.

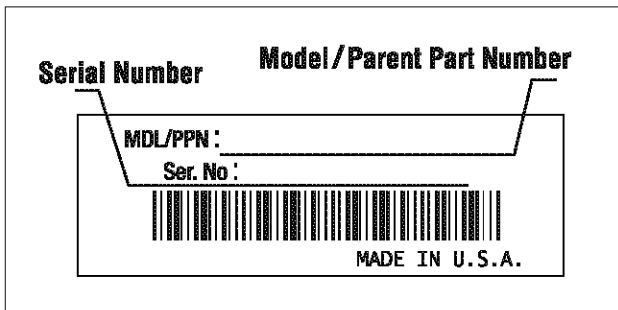

Copy the model / parent part number here: _____

Copy the serial number here: _____

CALLING CUSTOMER SUPPORT

If you have difficulty assembling this product or have any questions regarding the controls, operation or maintenance of this unit, please call the Customer Dealer Referral Line.



Call 1-877-282-8684 to reach the Customer Dealer Referral Line. Please have your unit's model number and serial number ready when you call. See previous section to locate this information.

Copyright© 2001 Cub Cadet LLC
All Rights Reserved

For more details about your unit, visit our website at www.cubcadet.com

Safety

The purpose of safety symbols is to attract your attention to possible dangers. The safety symbols, and their explanations, deserve your careful attention and understanding. The safety warnings do not by themselves eliminate any danger. The instructions or warnings they give are not substitutes for proper accident prevention measures.

SYMBOL MEANING



SAFETY ALERT SYMBOL: Indicates danger, warning, or caution. Attention is required in order to avoid serious personal injury. May be used in conjunction with other symbols or pictographs.

NOTE: *Advises you of information or instructions vital to the operation or maintenance of the equipment.*

! DANGER

Failure to obey a safety warning will result in serious injury to yourself or to others. Always follow the safety precautions to reduce the risk of fire, electric shock, and personal injury.

! WARNING

Failure to obey a safety warning can result in injury to yourself and others. Always follow the safety precautions to reduce the risk of fire, electric shock, and personal injury.

! CAUTION

Failure to obey a safety warning may result in property damage or personal injury to yourself or to others. Always follow the safety precautions to reduce the risk of fire, electric shock, and personal injury.

• IMPORTANT SAFETY INFORMATION •



WARNING: Engine Exhaust, some of its constituents, and certain vehicle components contain or emit chemicals known to State of California to cause cancer and birth defects or other reproductive harm.

READ ALL INSTRUCTIONS

BEFORE OPERATING

- Read the instructions carefully. Be familiar with the controls and proper use of the unit.
- Do not operate this unit when tired, ill, or under the influence of alcohol, drugs, or medication.
- Children and teens under the age of 15 must not use the unit, except for teens guided by an adult.
- Inspect the unit before use. Replace damaged parts. Check for fuel leaks. Make sure all fasteners are in place and secure. Replace cutting attachment parts that are cracked, chipped, or damaged in any way. Make sure the cutting attachment is properly installed and securely fastened. Be sure the cutting attachment shield is properly attached, and positioned as recommended. Failure to do so can result in personal injury to the operator and bystanders, as well as damage to the unit.
- Use only 0.105 inch (2.67 mm) diameter genuine manufacturer's replacement line. Never use metal-reinforced line, wire, chain, or rope, etc. These can break off and become a dangerous projectile.
- Be aware of the risk of injury to the head, hands and feet.

- Clear the area to be cut before each use. Remove all objects such as rocks, broken glass, nails, wire, or string which can be thrown or become entangled in the cutting attachment. Clear the area of children, bystanders, and pets. At a minimum, keep all children, bystanders and pets outside a 50 feet (15 m) radius; there still may be a risk to bystanders from thrown objects. Bystanders should wear eye protection. If you are approached, stop the engine and cutting attachment immediately.
- Squeeze the throttle control and check that it returns automatically to the idle position. Make all adjustments or repairs before using unit.
- Do not attach or operate this unit with any type of brushcutting blade or brushcutting attachment as the unit is currently setup. A brushcutter accessory kit is available by the manufacturer. See **Section 6, Maintenance** for the accessory part number. Use only the manufacturer's accessory kit.

SAFETY WARNINGS FOR GAS TRIMMERS

WARNING: Gasoline is highly flammable, and its vapors can explode if ignited. Take the following precautions:

- Store fuel only in containers specifically designed and approved for the storage of such materials.

Safety (continued)

- Always stop the engine and allow it to cool before filling the fuel tank. Never remove the cap of the fuel tank, or add fuel, when the engine is hot. Never operate the unit without the fuel cap securely in place. Loosen the fuel tank cap slowly to relieve any pressure in the tank.
- Add fuel in a clean, well-ventilated area outdoors where there are no sparks or flames. Slowly remove the fuel cap only after stopping engine. Do not smoke while fueling or mixing fuel. Wipe up any spilled fuel from the unit immediately.
- Avoid creating a source of ignition for spilled fuel. Do not start the engine until fuel vapors dissipate.
- Move the unit at least 30 feet (9.1 m) from the fueling source and site before starting the engine. Do not smoke, keep sparks and open flames from the area while adding fuel or operating the unit.

WHILE OPERATING

- Never start or run the unit inside a closed room or building. Breathing exhaust fumes can kill. Operate this unit only in a well ventilated area outdoors.
- Wear safety glasses or goggles that are marked as meeting ANSI Z87.1 standards, and ear/hearing protection when operating this unit. Wear a face or dust mask if the operation is dusty.
- Wear heavy, long pants, boots, gloves and a long sleeve shirt. Do not wear loose clothing, jewelry, short pants, sandals or go barefoot. Secure hair above shoulder level.
- The cutting attachment shield must always be in place while operating the unit. Do not operate unit without both trimming lines extended, and the proper line installed. Do not extend the trimming line beyond the length of the shield.
- This unit has a clutch. The cutting attachment remains stationary when the engine is idling. If it does not, have the unit adjusted by an authorized service technician.
- Adjust the D-Handle to your size to provide the best grip.
- Be sure the cutting attachment is not in contact with anything before starting the unit.
- Use the unit only in daylight or good artificial light.
- Avoid accidental starting. Be in the starting position whenever pulling the starter rope. The operator and unit must be in a stable position while starting. See **Section 5, Operation**.
- Use the right tool. Only use this tool for the purpose intended.
- Do not overreach. Always keep proper footing and balance.

- Always hold the unit with both hands when operating. Keep a firm grip on both the front and rear handle or grips.
- Keep hands, face, and feet at a distance from all moving parts. Do not touch or try to stop the cutting attachment when it is rotating.
- Do not touch the engine, gear housing or muffler. These parts get extremely hot from operation. When turned off they remain hot for a short time.
- Do not operate the engine faster than the speed needed to cut, trim or edge. Do not run the engine at high speed when not cutting.
- Always stop the engine when cutting is delayed or when walking from one cutting location to another.
- If you strike or become entangled with a foreign object, stop the engine immediately and check for damage. Do not operate before repairing damage. Do not operate the unit with loose or damaged parts.
- Stop and switch the engine to off for maintenance, repair, or for changing the cutting attachment or other attachments.
- Use only genuine manufacturer's replacement parts and accessories for this unit. These are available from your authorized service dealer. Use of any parts or accessories not authorized by the manufacturer could lead to serious injury to the user, or damage to the unit, and void your warranty.
- Keep unit clean of vegetation and other materials. They may become lodged between the cutting attachment and shield.
- To reduce fire hazard, replace faulty muffler and spark arrestor, keep the engine and muffler free from grass, leaves, excessive grease or carbon build up.

OTHER SAFETY WARNINGS

- Never store the unit, with fuel in the tank, inside a building where fumes may reach an open flame or spark.
- Allow the engine to cool before storing or transporting. Be sure to secure the unit while transporting.
- Store the unit in a dry area, locked up or up high to prevent unauthorized use or damage, out of the reach of children.
- Never douse or squirt the unit with water or any other liquid. Keep handles dry, clean and free from debris. Clean after each use, see **Cleaning and Storage** instructions.
- Keep these instructions. Refer to them often and use them to instruct other users. If you loan someone this unit, also loan them these instructions.

SAVE THESE INSTRUCTIONS

SAFETY AND INTERNATIONAL SYMBOLS

This operator's manual describes safety and international symbols and pictographs that may appear on this product. Read the operator's manual for complete safety, assembly, operating and maintenance and repair information.

SYMBOL

MEANING



- **SAFETY ALERT SYMBOL**

Indicates danger, warning, or caution. May be used in conjunction with other symbols or pictographs.



- **WARNING - READ OPERATOR'S MANUAL**

Read the Operator's Manual(s) and follow all warnings and safety instructions. Failure to do so can result in serious injury to the operator and/or bystanders.



- **FOR SERVICE INFORMATION, CALL:**

1 (877) 282-8684



- **WEAR EYE AND HEARING PROTECTION**

WARNING: Thrown objects and loud noise can cause severe eye injury and hearing loss. Wear eye protection meeting ANSI Z87.1 standards and ear protection when operating this unit.



- **KEEP BYSTANDERS AWAY**

WARNING: Keep all bystanders, especially children and pets, at least 50 feet (15 m) from the operating area.



- **PRIMER BULB**

Push primer bulb, fully and slowly, 5 to 7 times.



- **UNLEADED FUEL**

Always use clean, fresh unleaded fuel.



- **OIL**

Refer to operator's manual for the proper type of oil.



- **THROWN OBJECTS AND ROTATING CUTTER CAN CAUSE SEVERE INJURY**

WARNING: Do not operate without the cutting attachment shield in place. Keep away from the rotating cutting attachment.



- **ON/OFF STOP CONTROL**

ON / START / RUN



- **ON/OFF STOP CONTROL**

OFF OR STOP



- **HOT SURFACE WARNING**

Do not touch a hot muffler, gear housing or cylinder. You may get burned. These parts get extremely hot from operation. When turned off they remain hot for a short time.

Safety (continued)

SYMBOL



MEANING

• SHARP BLADE

WARNING: Sharp blade on cutting attachment shield. To prevent serious injury, do not touch line cutting blade.



• CHOKE CONTROL

A • **START** position.
B • **RUN** position.



WARNING: The operation of any power tool can cause foreign objects to be thrown into your eyes. This can lead to severe eye damage. Before commencing power tool operation, always wear safety glasses or goggles that are marked as meeting ANSI Z87.1 standards, and a full face shield when needed.

THE FOLLOWING ARE FOR REFERENCE WHEN THE UNIT IS ASSEMBLED WITH THE MANUFACTURER'S BRUSHCUTTER ACCESSORY KIT



WARNING

Do not attach or operate this unit with any type of brushcutting blade or brushcutting attachment as the unit is currently setup. A brushcutter accessory kit is available by the manufacturer. See Section 6, Maintenance for the accessory part number. Use only the manufacturer's accessory kit. Failure to do so may result in serious personal injury to yourself or others and/or damage to the unit



• BRUSHCUTTERS • Replace dull blade.

Do not sharpen the cutting blade. Sharpening the blade can cause the blade tip to break off while in use. This can result in severe personal injury.



• TRIMMER/BRUSHCUTTER SAFETY

WARNING: Thrown objects and rotating cutter can cause severe injury. Keep bystanders, especially children and pets, at least 50 feet (15 m) away from the cutting area. The cutting attachment shield must be used when using the trimmer cutting attachment.

Know Your Unit

APPLICATIONS

As a trimmer;

- Cutting grass and weeds.
- Edging
- Decorative trimming around trees, fences, etc.

With the optional brushcutter accessory kit;

- Cutting weeds and light bush of up to 1/2 inch in diameter.

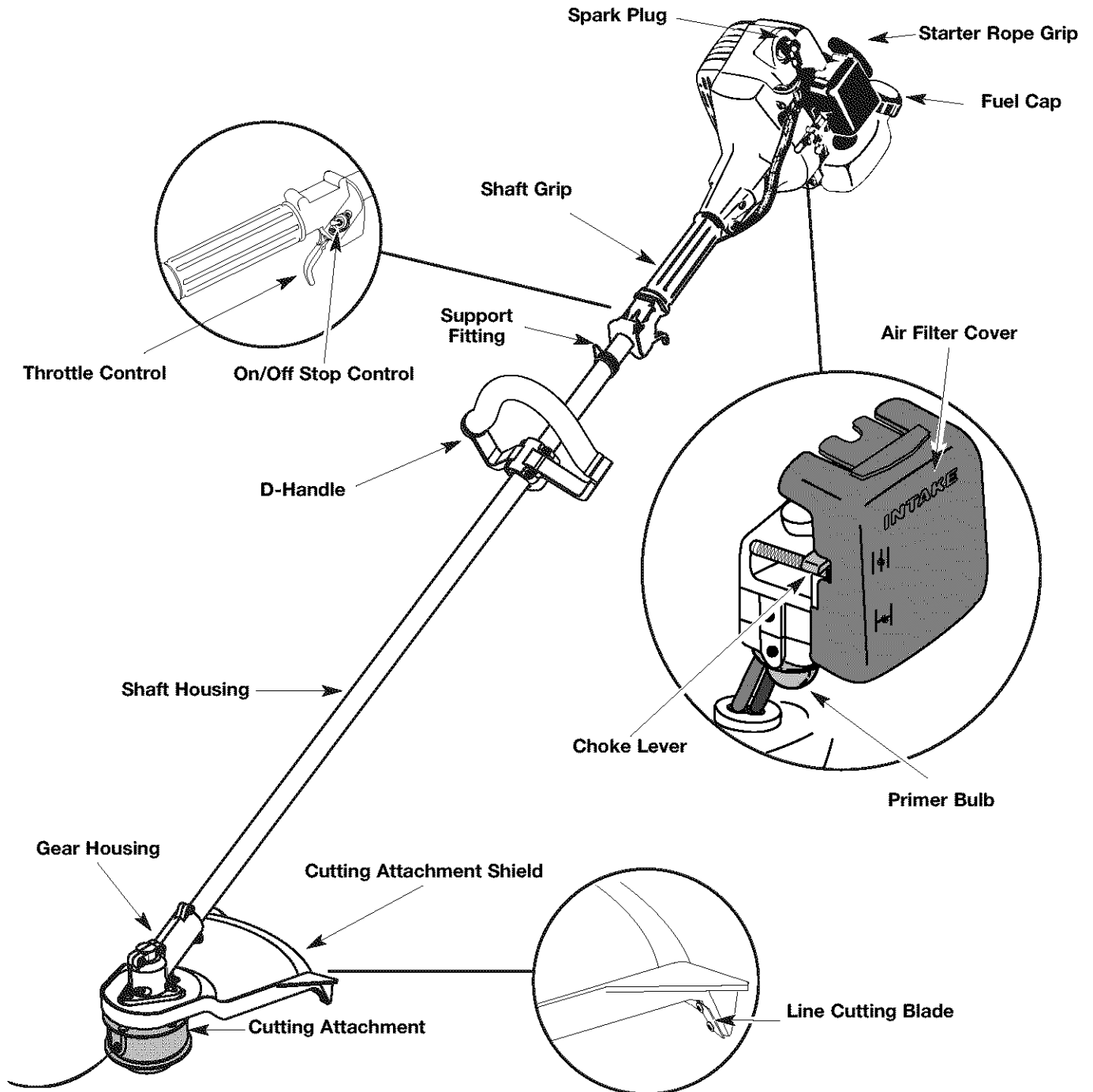

Section 3

Assembly

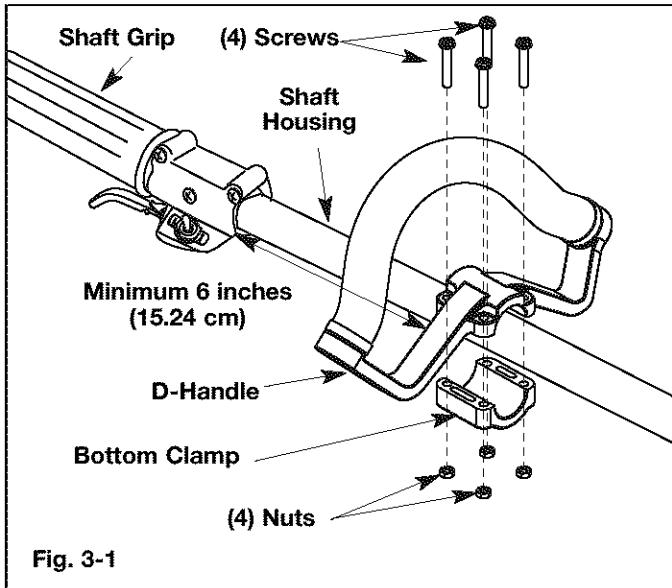

On some units, the D-handle may be preinstalled and only require loosening the screws and adjusting the D-handle to the operator. Go to step 4 for adjusting the D-handle if preinstalled.

INSTALLING AND ADJUSTING THE D-HANDLE

1. Remove the screws, nuts and bottom clamp piece that were installed on the D-handle for shipping.
2. Place D-handle the over the shaft housing and onto the bottom clamp (Fig. 3-1). Place it a minimum of 6 inches (15.24 cm) from the end of the shaft grip.
3. Hold each hex nut in the bottom clamp recess with a finger. Start screws with a screwdriver. Do not tighten until you make the handle adjustment.
4. If it was preinstalled, loosen the screws on the D-handle just enough to move the D-handle.
5. While holding the unit in the operating position (Fig. 3-2), position the D-handle to the location that provides you the best grip.
6. Tighten the clamp screws evenly, until the D-handle is secure.

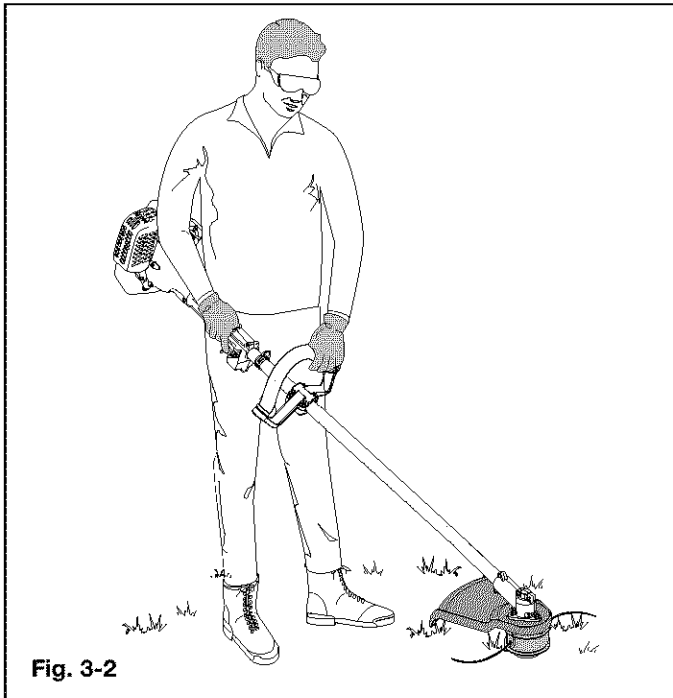

Oil and Fuel

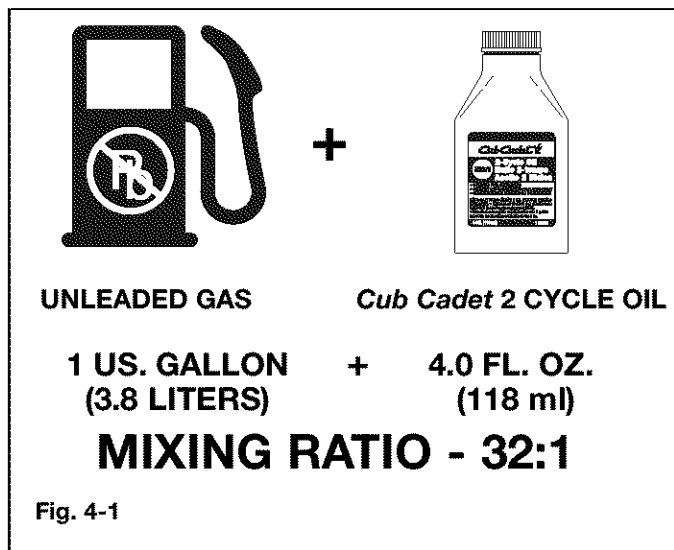

Oil and Gas Mixing Instructions

Old and/or improperly mixed fuel are the main reasons for the unit not running properly. Be sure to use fresh, clean unleaded fuel. Follow the instructions carefully for the proper fuel/oil mixture.

Definition of Blended Fuels

Today's fuels are often a blend of gasoline and oxygenates such as ethanol, methanol or MTBE (ether). Alcohol-blended fuel absorbs water. As little as 1% water in the fuel can make fuel and oil separate. It forms acids when stored. When using alcohol-blended fuel, use fresh fuel (less than 60 days old).

Using Blended Fuels

If you choose to use a blended fuel, or its use is unavoidable, follow recommended precautions.

- Always use fresh fuel mix per your operator's manual.
- Always agitate the fuel mix before fueling the unit.
- Drain the tank and run the engine dry before storing the unit.

Using Fuel Additives

The bottle of Cub Cadet 2-Cycle oil that came with your unit contains a fuel additive which will help inhibit corrosion and minimize the formation of gum deposits. It is recommended that you use only Cub Cadet 2-Cycle oil with this unit.

If unavailable, use a good 2-cycle oil designed for air-cooled engines along with a fuel additive, such as STA-BIL® Gas Stabilizer or an equivalent. Add 0.8 oz. (23 ml) of fuel additive per gallon of fuel according to the instructions on the container. NEVER add fuel additives directly to the unit's fuel tank.

! CAUTION

For proper engine operation and maximum reliability, pay strict attention to the oil and fuel mixing instructions on the 2-cycle oil container. Using improperly mixed fuel can severely damage the engine.

Thoroughly mix the proper ratio of 2-cycle engine oil with unleaded gasoline in a separate fuel can. Use a 32:1 fuel/oil ratio. Do not mix them directly in the engine fuel tank. See Figure 4-1 for specific gas and oil mixing ratios.

NOTE: One gallon (3.8 liters) of unleaded gasoline mixed with one 4 oz. (118 ml) bottle of Cub Cadet 2-CYCLE OIL makes a 32:1 fuel/oil ratio.

! WARNING

Gasoline is extremely flammable. Ignited Vapors may explode. Always stop the engine and allow it to cool before filling the fuel tank. Do not smoke while filling the tank. Keep sparks and open flames at a distance from the area.

! WARNING

Remove fuel cap slowly to avoid injury from fuel spray. Never operate the unit without the fuel cap securely in place.

! WARNING

Add fuel in a clean, well ventilated area outdoors. Wipe up any spilled fuel immediately. Avoid creating a source of ignition for spilt fuel. Do not start the engine until fuel vapors dissipate.

NOTE: Dispose of the old fuel/oil mix in accordance to Federal, State, and Local regulations.

Section 5

Operation

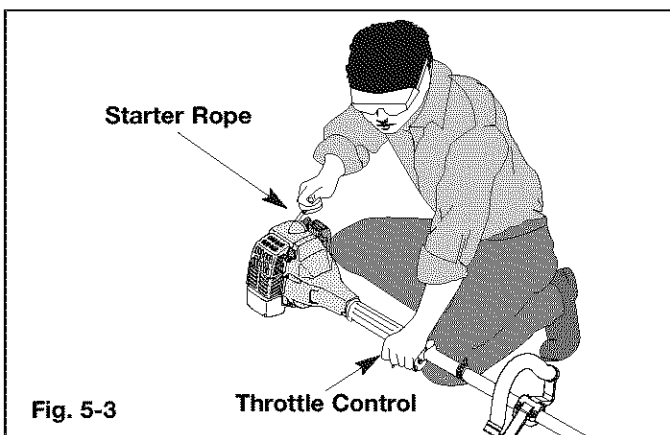
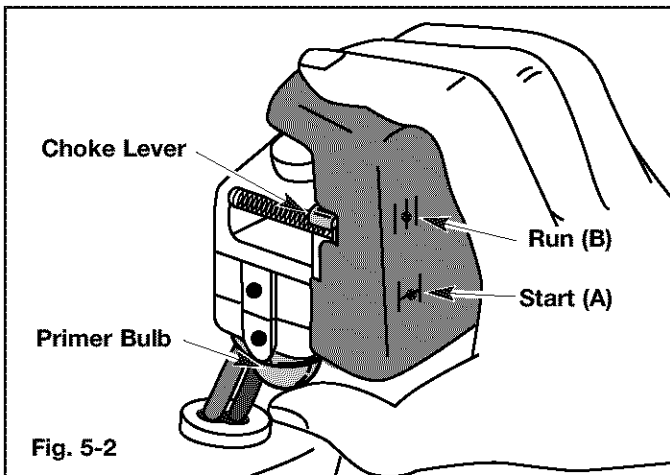
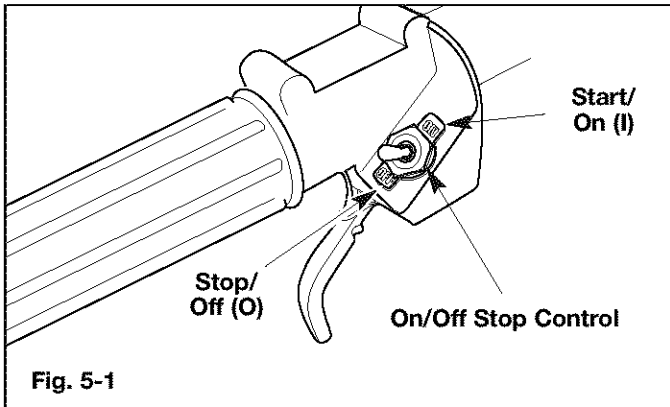

STARTING INSTRUCTIONS

! WARNING

Operate this unit only in a well ventilated area outdoors. Carbon monoxide exhaust fumes can be lethal in a confined area.

! WARNING

Avoid accidental starting. Be in the starting position whenever pulling the starting rope. To avoid serious personal injury, the operator and unit must be in a stable position while starting.

STARTING INSTRUCTIONS

1. Mix gas with oil. Fill fuel tank with fuel/oil mixture. See Section 4, Oil and Fuel.
2. Put the On/Off Stop Control in the **START (I)** position (Fig. 5-1).
3. Fully press and release primer bulb slowly 5 to 7 times. Fuel should be felt and visible in the bulb (Fig. 5-2). If fuel hasn't entered the bulb, press three more times, or until it does.
4. Place the choke lever in the **START (A)** position (Fig. 5-2).
5. With the unit on the ground, squeeze the throttle control and hold. Pull starter rope briskly (Fig. 5-3). Continue pulling until the engine sounds as though it wants to run (normally 2 to 5 pulls).

NOTE: Squeeze the throttle control until the engine has started and warmed up.

6. Place the choke lever in the **RUN (B)** position (Fig. 5-2).
7. Pull starter rope briskly 1 to 3 times to start the engine (Fig. 5-3).
8. If the engine does not start, repeat steps 4 through 7.

NOTE: If the engine floods while trying to start, place the choke lever in the **RUN (B)** position. Squeeze the throttle control. Pull the starter rope briskly. The engine should start within three (3) to eight (8) pulls.

9. Squeeze the throttle control to warm up engine for 5 to 10 seconds. Place the choke lever in the **RUN (B)** position (Fig. 5-2).

NOTE: Choking is unnecessary when starting a warm engine. Put the On/Off Stop Control in the **START (I)** position (Fig. 5-1), and the choke lever in the **RUN (B)** position (Fig. 5-2).

STOPPING INSTRUCTIONS

1. Release your hand from the throttle control (Fig. 5-3). Allow the engine to idle.
2. To stop the engine, put the On/Off Stop Control in the **STOP [O]** position (Fig. 5-1).



Fig. 5-4

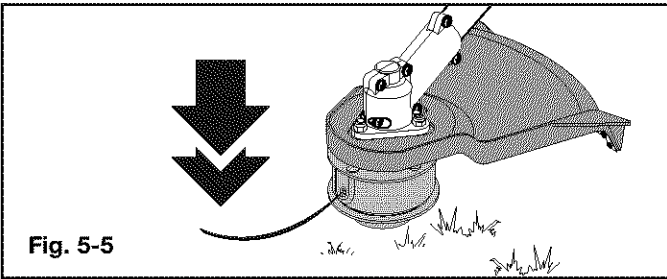

Fig. 5-5

HOLDING THE TRIMMER

! WARNING

Always wear eye, hearing, foot and body protection to reduce the risk of injury when operating this unit.

Before operating the unit, stand in the operating position (Fig. 5-4). Check for the following:

- The operator is wearing eye protection and proper clothing.
- The right arm is slightly bent, and the hand is holding the shaft grip.
- The left arm is straight, and the hand is holding the D-handle.
- The unit is at waist level.
- The cutting attachment is parallel to the ground and easily contacts the vegetation to be cut without the operator having to bend over.

ADJUSTING TRIMMING LINE LENGTH

The Bump Head cutting attachment allows you to release trimming line without stopping the engine. To release more line, lightly tap the cutting attachment on the ground (Fig. 5-5) while operating the trimmer at high speed.

NOTE: Always keep the trimming line fully extended. Line release becomes more difficult as cutting line becomes shorter.

Each time the head is bumped, about 1 inch (25.4 mm) of trimming line is released. A blade in the cutting attachment shield will cut the line to the proper length if excess line is released.

For best results, tap the Bump Head on bare ground or hard soil. If line release is attempted in tall grass, the engine may stall. Always keep the trimming line fully extended. Line release becomes more difficult as the cutting line becomes shorter.

NOTE: Do not rest the Bump Head on the ground while the unit is running .

! CAUTION

Do not remove or alter the line cutting blade assembly. Excessive line length will make the clutch overheated. This may lead to serious personal injury or damage to the unit.

Some line breakage will occur from:

- Entanglement with foreign matter
- Normal line fatigue
- Attempting to cut thick, stalky weeds
- Forcing the line into objects such as walls or fence posts

TIPS FOR BEST TRIMMING RESULTS

- Keep the cutting attachment parallel to the ground.
- Do not force the cutting attachment. Allow the tip of the line to do the cutting, especially along walls. Cutting with more than the tip will reduce cutting efficiency and may overload the engine.
- Cut grass over 8 inches (200 mm) by working from top to bottom in small increments to avoid premature line wear or engine drag.
- Cut from left to right whenever possible. Cutting to the right improves the unit's cutting efficiency. Clippings are thrown away from the operator.
- Slowly move the trimmer into and out of the cutting area at the desired height. Move either in a forward-backward or side-to-side motion. Cutting shorter lengths produces the best results.
- Trim only when grass and weeds are dry.
- The life of your cutting line is dependent upon;
 - Following the previous trimming techniques
 - What vegetation is being cut
 - Where it's being cut

For example, the line will wear faster when trimming against a foundation wall as opposed to trimming around a tree.

Operation (continued)

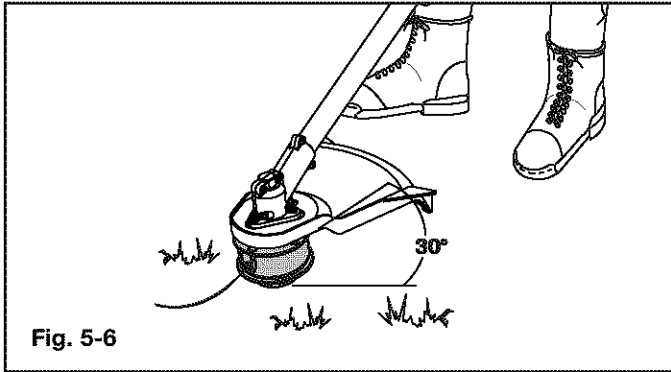

DECORATIVE TRIMMING

Decorative trimming is accomplished by removing all vegetation around trees, posts, fences, etc.

Rotate the whole unit so that the cutting attachment is at a 30° angle to the ground (Fig. 5-6).

Section 6

MAINTENANCE

NOTE: Some maintenance procedures may require special tools or skills. If you are unsure about these procedures take your unit to an authorized service dealer.

MAINTENANCE SCHEDULE

These required maintenance procedures should be performed at the frequency stated in the table. They should also be included as part of any seasonal tune-up.

WARNING

To prevent serious injury, never do maintenance or repairs with unit running. Always do maintenance and repairs on a cool unit. Disconnect spark plug wire to ensure the unit will not start.

WHEN	MAINTENANCE NEEDED	GO TO:
Before Starting Engine	Fill fuel tank with correct oil and fuel mixture.	Page 9
Every 10 Hours	Clean and re-oil air filter.	Page 15
Every 25 Hours	Check spark arrestor and clean Check spark plug condition and gap	Page 15 Page 17

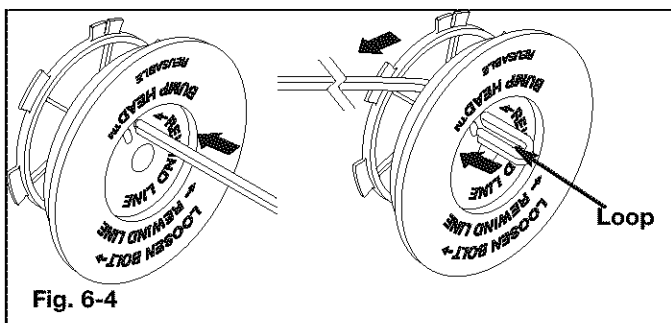
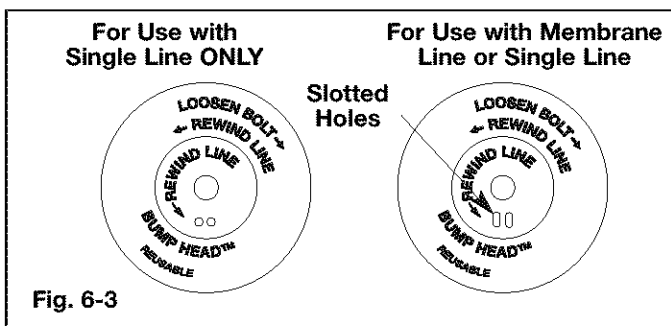
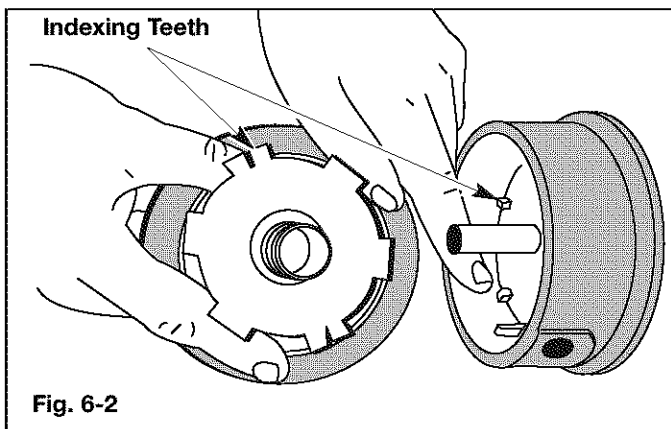
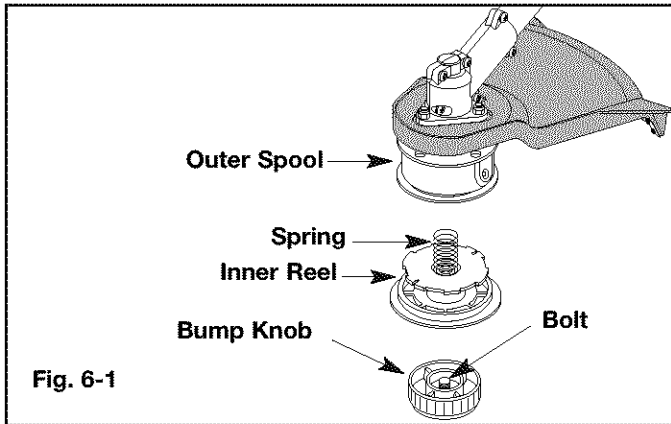

LINE INSTALLATION

This section covers both Membrane line and standard single line installation.

Always use manufacturer's 0.105 inch (2.67 mm) replacement line. Line other than specified may make the engine overheat or fail.

! WARNING

Never use metal-reinforced line, wire, chain, or rope, etc. These can break off and become a dangerous projectile.

There are two methods to replace the trimming line.

- Wind the inner reel with new line
- Install a prewound inner reel

Winding the Existing Inner Reel

1. Hold the outer spool with one hand and unscrew the Bump Knob clockwise (Fig. 6-1). Inspect the bolt inside the Bump Knob to make sure it moves freely. Replace the Bump Knob if damaged.
2. Remove the inner reel from the outer spool (Fig. 6-1).
3. Remove spring from the inner reel (Fig. 6-1).
4. Use a clean cloth to clean the the inner reel, spring, shaft, and inner surface of the outer spool.
5. Check the indexing teeth on the inner reel and outer spool for wear (Fig. 6-2). If necessary, remove burrs or replace the reel and spool.

NOTE: Membrane line can only be used with the inner reel with the slotted holes. Single line can be used on either type of inner reel. Use figure 6-3 to identify the inner reel you have.

NOTE: Always use the correct line length when installing trimming line on the unit. The line may not release properly if the line is too long.

Single Line Installation

Go To Step 8 for Membrane Line Installation

6. Take approximately 30 feet (9.1 m) of new trimming line, loop it into two equal lengths. Insert each end of the line through one of the two holes in the inner reel (Fig. 6-4). Pull the line through the inner reel so that the loop is as small as possible.
7. Wind the lines in tight even layers, onto the reel (Fig. 6-5). Wind the line in the direction indicated on the inner reel. Place your index finger between the two lines to stop the lines from overlapping. Do not overlap the ends of the line. Proceed to step 11.

Maintenance (continued)

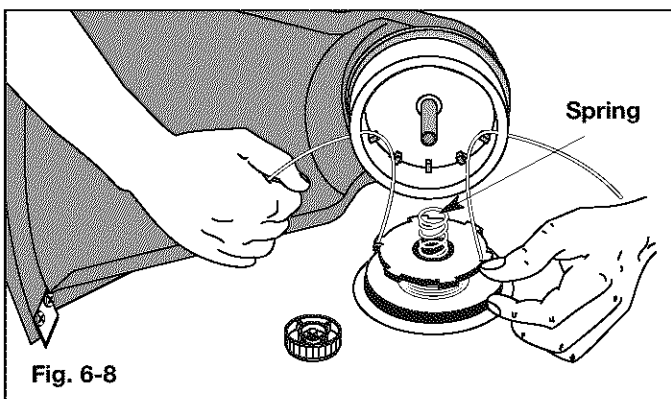
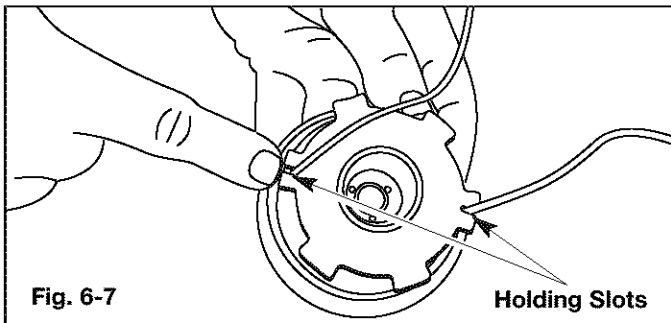
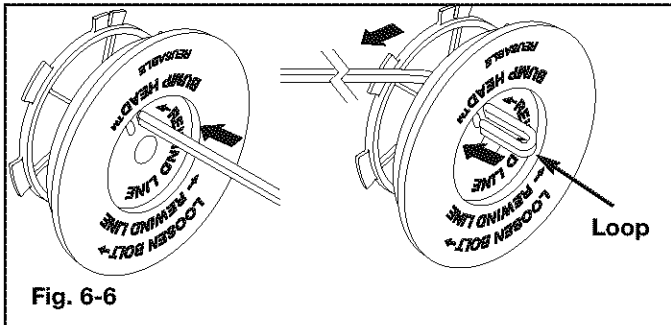
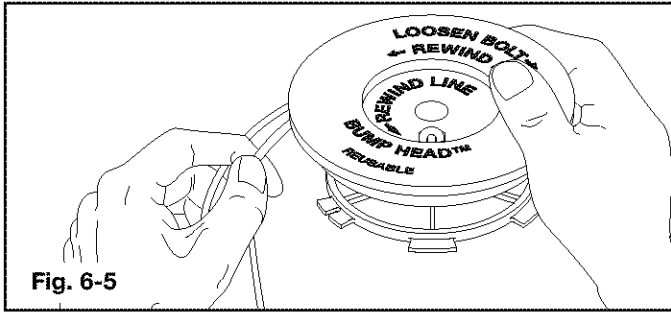

Membrane Line Installation

8. Take approximately 15 feet (4.6 m) of new trimming line. Insert one end of the line through one of the two holes in the inner reel (Fig. 6-6). Pull the line through the inner reel until only about 4 inches is left out.
9. Insert the end of the line into the open hole in the inner reel and pull the line tight to make the loop as small as possible (Fig. 6-6).
10. Before winding, split the line back about 6 inches.
11. Wind the line in tight even layers in the direction indicated on the inner reel.

NOTE: Failure to wind the line in the direction indicated will cause the cutting attachment to operate incorrectly.

12. Insert the ends of the line into the two holding slots (Fig. 6-7).
13. Insert the ends of the line through the eyelets in the outer spool and place inner reel with spring inside the outer spool (Fig. 6-8). Push the inner reel and outer spool together. While holding the inner reel and outer spool, grasp the ends and pull firmly to release the line from the holding slots in the reel.

NOTE: The spring must be assembled on the inner reel before reassembling the cutting attachment.

14. Hold the inner reel in place and install the Bump Knob by turning counterclockwise. Tighten securely.

INSTALLING A PREWOUND REEL

1. Hold the outer spool with one hand and unscrew the Bump Knob clockwise (Fig. 6-1). Inspect the bolt inside the Bump Knob to make sure it moves freely. Replace the Bump Knob if damaged.
2. Remove the old inner reel from the outer spool (Fig. 6-1).
3. Remove the spring from the old inner reel (Fig. 6-1).
4. Place the spring in the new inner reel.

NOTE: The spring must be assembled on the inner reel before reassembling the cutting attachment.

5. Insert the ends of the line through the eyelets in the outer spool (Fig. 6-8).
6. Place the new inner reel inside the outer spool. Push the inner reel and outer spool together. While holding the inner reel and outer spool, grasp the ends and pull firmly to release the line from the holding slots in the spool.
7. Hold the inner reel in place and install the Bump Knob by turning counterclockwise. Tighten securely.

Replacement Parts:

See **Accessories / Replacement Parts** on page 18.

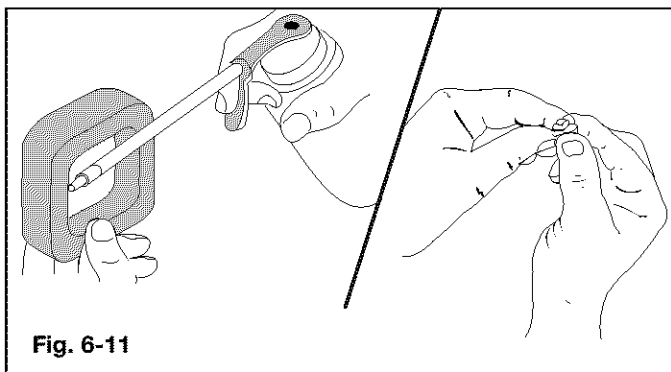
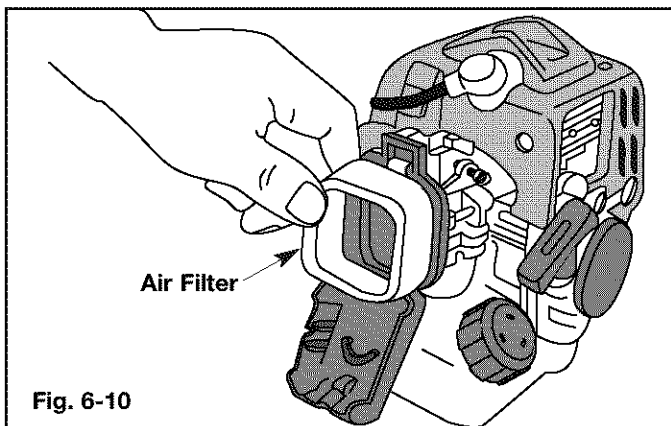
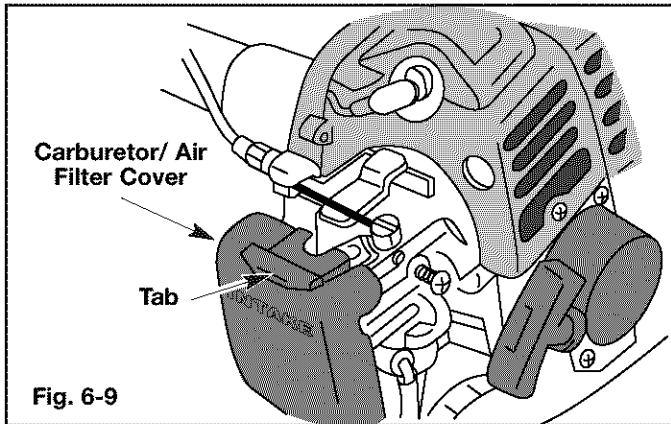

AIR FILTER MAINTENANCE

Cleaning the Air Filter

! WARNING

To avoid serious personal injury, always turn your trimmer off and allow it to cool before you clean or do any maintenance on it.

Clean and re-oil the air filter every 10 hours of operation. It is an important item to maintain. Not maintaining the air filter will **VOID** the warranty.

1. Remove the carburetor/air filter cover by pushing on the tab on top of the cover (Fig. 6-9).
2. Remove the air filter (Fig. 6-10).
3. Wash the filter in detergent and water. Rinse the filter thoroughly and allow it to dry.
4. Apply enough clean SAE 30 motor oil to lightly coat the filter (Fig. 6-11).
5. Squeeze the filter to spread and remove excess oil (Fig. 6-11).
6. Reinstall the filter (Fig. 6-10) and air filter cover (Fig. 6-9).

NOTE: If the unit is operated without the air filter, you will **VOID** the warranty.

SPARK ARRESTOR MAINTENANCE

! WARNING

To avoid serious personal injury, always turn your trimmer off and allow it to cool before you clean or do any maintenance on it.

1. Turn the powerhead so the back of the engine is facing forward. In this position, the starter rope is to the left (Fig. 6-12).

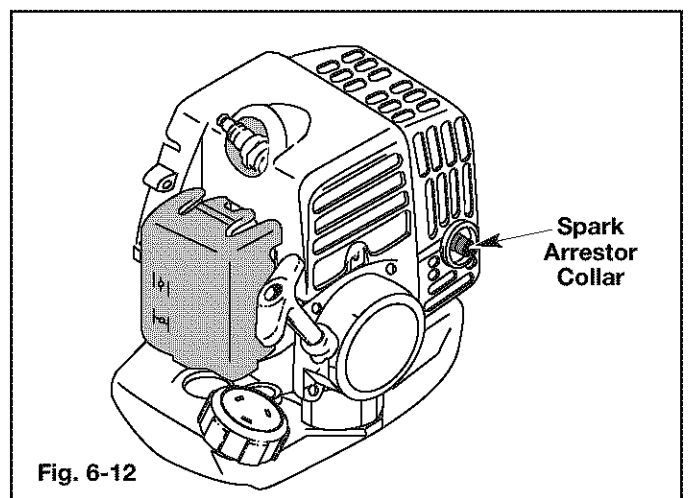

Maintenance (continued)

2. Use a needlenose pliers to grasp the collar of the spark arrestor and pull it out of the muffler (Fig. 6-13).

NOTE: Use only a needlenose pliers. Other pliers or tools may damage the spark arrestor.

3. Clean the spark arrestor with a wire brush. Replace if damaged or unable to clean thoroughly.
4. Reinstall spark arrestor. Use the needlenose pliers to gently push the spark arrestor back into the muffler until it snaps into place.

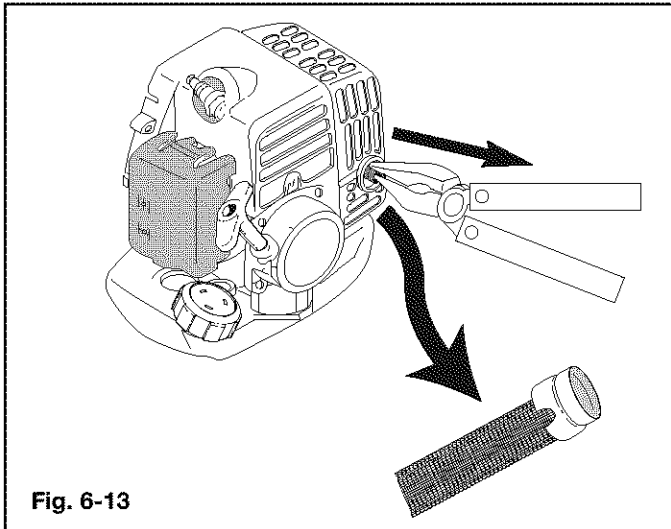

Fig. 6-13

CARBURETOR ADJUSTMENT

The idle speed of the engine is adjustable by the screw next to the air filter cover (Fig 6-14).

NOTE: Careless adjustments can seriously damage your unit. An authorized service dealer should make carburetor adjustments.

Check Fuel Mixture

Old and/or improperly mixed fuel is usually the reason for the unit not running properly. Drain and refill the tank with fresh, properly mixed fuel prior to making any adjustments. See **Section 5, Oil and Fuel**.

Clean Air Filter

The condition of the air filter is important to the operation of the unit. A dirty air filter will restrict air flow and change the air/fuel mixture. This is often mistaken for an out of adjustment carburetor. Check the condition of the air filter before adjusting the idle speed screw. See **Section 6, Maintenance**.

Adjust Idle Speed Screw

! WARNING

The cutting attachment may be spinning during idle speed adjustment. Wear protective clothing and observe all safety instructions to prevent serious personal injury.

If after checking the fuel mixture and cleaning the air filter the engine still will not idle, adjust the idle speed screw as follows.

1. Start the engine and let it run at a high idle for a minute to warm up.
2. Release the throttle trigger and let the engine idle. If the engine stops, insert a small phillips or flat blade screwdriver into the screw next to the air filter cover (Fig. 6-14). Turn the idle speed screw in, clockwise, 1/8 of a turn at a time (as needed) until the engine idles smoothly.

NOTE: The cutting attachment should not rotate when the engine idles.

3. If the cutting attachment rotates when the engine idles, turn the idle speed screw counterclockwise 1/8 of a turn at a time (as needed), to reduce idle speed.

Checking the fuel mixture, cleaning the air filter, and adjusting the idle speed screw should solve most engine problems.

If not and:

- The engine will not idle,
- The engine hesitates or stalls on acceleration,
- There is a loss of engine power,

have the carburetor adjusted by an authorized service dealer.

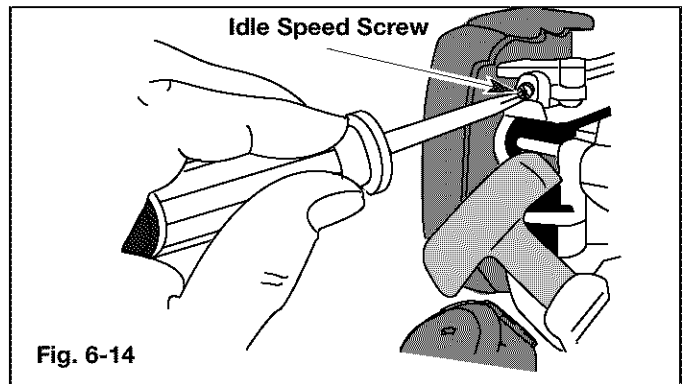

Fig. 6-14

REPLACING THE SPARK PLUG

Use a Champion RCJ6Y spark plug (or equivalent). The correct air gap is **0.025 inch (0.655 mm)**. Remove the plug after every 25 hours of operation and check its condition.

1. Stop the engine and allow it to cool. Grasp the plug wire firmly and pull the cap from the spark plug.
2. Clean dirt from around the spark plug. Remove the spark plug from the cylinder head by turning a 5/8 inch socket counterclockwise.
3. Replace cracked, fouled or dirty spark plug. Set the air gap at 0.025 inch (0.655 mm) using a feeler gauge (Fig. 6-15).

CAUTION

Do not sand blast, scrape, or clean electrodes. Grit in the engine could damage the cylinder.

4. Install a correctly gaped spark plug in the cylinder head. Tighten by turning the 5/8 inch socket clockwise until snug.

If using a torque wrench torque to:
110-120 in.•lb. (12.3-13.5 N•m).

Do not over tighten.

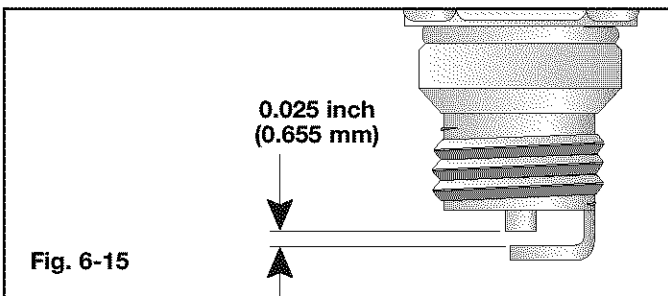

Fig. 6-15

ACCESSORIES/REPLACEMENT PARTS

Spark Plug	791-181765
Spark Arrestor	791-181696
Replacement Line Cartridge	153-1160
Inner Reel Spring	791-610636
Bump Head Knob Assembly	791-180814
Fuel Cap	791-180000
Brushcutter Accessory Kit	41AM079G100
Shoulder Harness	791-682075
Tip-and-Pour 2-Cycle Oil (16 oz.)	791-180965

These replacement parts can be purchased at the retailer from which you bought your trimmer, or your local *Cub Cadet* dealer.

CLEANING

WARNING

To avoid serious personal injury, always turn your trimmer off and allow it to cool before you clean or do any maintenance on it.

Use a small brush to clean off the outside of the unit. Do not use strong detergents. Household cleaners that contain aromatic oils such as pine and lemon, and such as kerosene, can damage plastic housing or handle. Wipe off any moisture with a soft cloth.

STORAGE

- Never store the unit with gasoline in the tank where fumes may reach an open flame or spark.
- Allow the engine to cool before storing.
- Store the unit locked up to prevent unauthorized use or damage.
- Store the unit in a dry, well ventilated area.
- Store the unit out of the reach of children.

LONG TERM STORAGE

If the unit will be stored for an extended time,

1. Drain all fuel from the gas tank into a container. Do not use fuel that has been stored for more than 60 days. Dispose of the old fuel in accordance to Federal, State, and Local regulations.
2. Start the engine and allow it to run until it stalls. This ensures that all gasoline has been drained from the carburetor.
3. Allow the engine to cool. Remove the spark plug and put 1 oz. (30 ml) of high quality motor oil into the cylinder. Pull the starter rope slowly to distribute the oil. Reinstall the spark plug.

NOTE: Remove the spark plug and drain all of the oil from the cylinder before attempting to start the trimmer after storage.

4. Thoroughly clean the unit and inspect for any loose or damaged parts. Repair or replace damaged parts and tighten loose screws, nuts or bolts. The unit is ready for storage.

TRANSPORTING

- Allow the engine to cool before transporting.
- Secure the unit while transporting.
- Drain the gas tank before transporting.
- Tighten gas cap before transporting.

Section 7

Troubleshooting

ENGINE WILL NOT START

CAUSE

On/Off Stop Control is in STOP position
Empty fuel tank
Primer bulb wasn't pressed enough
Engine flooded

Old or improperly mixed fuel
Fouled spark plug
Plugged spark arrestor

ACTION

Turn On/Off Stop Control to START
Fill fuel tank with properly mixed fuel
Press primer bulb fully and slowly 5-7 times
Use starting procedure with choke lever in the RUN position, Pg. 11
Drain gas tank / Add fresh fuel mixture
Replace or clean the spark plug
Clean or replace spark arrestor

ENGINE WILL NOT IDLE

CAUSE

Air Filter is Plugged
Old or improperly mixed fuel
Improper carburetor adjustment

ACTION

Replace or clean the air filter
Drain gas tank / Add fresh fuel mixture
Adjust per instruction Pg. 16

ENGINE WILL NOT ACCELERATE

CAUSE

Old or improperly mixed fuel
Improper carburetor adjustment

Cutting attachment bound with grass
Dirty air filter
Plugged spark arrestor

ACTION

Drain gas tank / Add fresh fuel mixture
Take to an authorized service dealer for carburetor adjustment
Stop the engine and clean the cutting attachment
Clean or replace the air filter
Clean or replace spark arrestor

ENGINE LACKS POWER OR STALLS WHEN CUTTING

CAUSE

Old or improperly mixed fuel
Improper carburetor adjustment

Fouled spark plug
Plugged spark arrestor

ACTION

Drain gas tank / Add fresh fuel mixture
Take to an authorized service dealer for carburetor adjustment
Replace or clean the spark plug
Clean or replace spark arrestor

CUTTING ATTACHMENT WILL NOT ADVANCE LINE

CAUSE

Cutting attachment bound with grass
Cutting attachment out of line
Inner reel bound up
Cutting head dirty
Line welded

Line twisted when refilled
Not enough line is exposed

ACTION

Stop the engine and clean cutting attachment
Refill with new line
Replace the inner reel
Clean inner reel and outer spool
Disassemble, remove the welded section and rewind the line
Disassemble and rewind the line
Push the Bump Knob and pull out line until 4 inches (102 mm) of line is outside of the cutting attachment

Specifications

ENGINE

Engine Type	Air-Cooled, 2-Cycle
Displacement	1.4 cu. in. (25cc)
Clutch Type	Centrifugal
Idle Speed RPM	2,400-3,600 rpm
Operating RPM (Trimmer)	7,000-8,600 rpm
Ignition Type	Electronic
On/Off Stop Control	Toggle Switch
Lubrication	Fuel/Oil Mixture
Fuel/Oil Ratio	32:1
Fuel	Unleaded
Carburetor	Diaphragm, All-Position
Starter	Auto Rewind
Muffler	Baffled with Guard
Throttle	Manual Spring Return
Fuel Tank Capacity	20 oz (591 ml)

DRIVE SHAFT & CUTTING ATTACHMENT

Drive Shaft Housing	Aluminum Tube
Throttle Control	Finger-Tip Trigger
Unit Weight (No Fuel, with D-handle, Cutting attachment shield and Cutting attachment)	11 lbs (4.9 kg)
Cutting Mechanism	Dual String Cutting Head
Line Spool	Bump Line Releaser
Line Spool Diameter	4 inches (101.6 mm)
Trimming Line Diameter	0.105 inches (2.67 mm)
Cutting Path Diameter	18 inches (44.0 cm)

MANUFACTURER'S LIMITED WARRANTY FOR:



The limited warranty set forth below is given by Cub Cadet LLC with respect to new merchandise purchased and used in the United States, its possessions and territories.

Cub Cadet LLC warrants this product against defects in material and workmanship for a period of two (2) years commencing on the date of original purchase and will, at its option, repair or replace, free of charge, any part found to be defective in material or workmanship. This limited warranty shall only apply if this product has been operated and maintained in accordance with the Operator's Manual furnished with the product, and has not been subject to misuse, abuse, commercial use, neglect, accident, improper maintenance, alteration, vandalism, theft, fire, water or damage because of other peril or natural disaster. Damage resulting from the installation or use of any accessory or attachment not approved by Cub Cadet LLC for use with the product(s) covered by this manual will void your warranty as to any resulting damage. This warranty is limited to ninety (90) days from the date of original retail purchase for any Cub Cadet product that is used for rental or commercial purposes, or any other income-producing purpose.

HOW TO OBTAIN SERVICE: Warranty service is available, WITH PROOF OF PURCHASE THROUGH YOUR LOCAL AUTHORIZED SERVICE DEALER. To locate the dealer in your area, visit our website at www.cubcadet.com, check for a listing in the Yellow Pages, call 1 (877) 282-8684 or write to P.O. Box 361131, Cleveland, OH 44136-9722.

This limited warranty does not provide coverage in the following cases:

- A. Tune-ups - Spark Plugs, Carburetor Adjustments, Filters
- B. Wear items - Bump Knobs, Outer Spools, Cutting Line, Inner Reels, Starter Pulley, Starter Ropes, Drive Belts
- C. Cub Cadet LLC does not extend any warranty for products sold or exported outside of the United States of America, its possessions and territories, except those sold through Cub Cadet's authorized channels of export distribution.

Cub Cadet LLC reserves the right to change or improve the design of any Cub Cadet Product without assuming any obligation to modify any product previously manufactured.

No implied warranty, including any implied warranty of merchantability or fitness for a particular purpose, applies after the applicable period of express written warranty above as to the parts as identified. No other express warranty or guaranty, whether written or oral, except as mentioned above, given by any person or entity, including a dealer or retailer, with respect to any product shall bind Cub Cadet LLC During the period of the Warranty, the exclusive remedy is repair or replacement of the product as set forth above. (Some states do not allow limitations on how long an implied warranty lasts, so the above limitation may not apply to you.)

The provisions as set forth in this Warranty provide the sole and exclusive remedy arising from the sales. Cub Cadet LLC shall not be liable for incidental or consequential loss or damages including, without limitation, expenses incurred for substitute or replacement lawn care services, for transportation or for related expenses, or for rental expenses to temporarily replace a warranted product. (Some states do not allow limitations on how long an implied warranty lasts, so the above limitation may not apply to you.)

In no event shall recovery of any kind be greater than the amount of the purchase price of the product sold. Alteration of the safety features of the product shall void this Warranty. You assume the risk and liability for loss, damage, or injury to you and your property and/or to others and their property arising out of the use or misuse or inability to use the product.

This limited warranty shall not extend to anyone other than the original purchaser, original lessee or the person for whom it was purchased as a gift.

How State Law Relates to this Warranty: This warranty gives you specific legal rights, and you may also have other rights which vary from state to state.

To locate your nearest service dealer dial
1 (877) 282-8684

Cub Cadet LLC
P.O. Box 361131
Cleveland, OH 44136-0019