



Operator's Manual



4-Cycle Gasoline
Trimmer / Brushcutter
Model TB490BC

IMPORTANT: READ SAFETY RULES AND INSTRUCTIONS CAREFULLY

NOTE: For users on U.S. Forest Land and in the states of California, Maine, Oregon and Washington. All U.S. Forest Land and the state of California (Public Resources Codes 4442 and 4443), Oregon and Washington require, by law that certain internal combustion engines operated on forest brush and/or grass-covered areas be equipped with a spark arrestor, maintained in effective working order, or the engine be constructed, equipped and maintained for the prevention of fire. Check with your state or local authorities for regulations pertaining to these requirements. Failure to follow these requirements could subject you to liability or a fine. This unit is factory equipped with a spark arrestor. If it requires replacement, **Accessory Part 791-180890 Spark Arrestor Screen** is available by contacting the service department at Troy-Bilt LLC, P.O. Box 361131 Cleveland, Ohio 44136-0019.

TROY-BILT LLC, P.O. BOX 361131, CLEVELAND, OH 44136-0019

P/N 771-10661 (11/01 rev. P00)
PRINTED IN USA

TABLE OF CONTENTS

Content	Page
Calling Customer Support	2
Rules for Safe Operation	3
Know Your Unit	7
Assembly Instructions	8
Oil and Fuel Information	11
Starting/Stopping Instructions	13
Operating Instructions	14
Maintenance and Repair Instructions	17
Accessories and Replacement Parts	24
Cleaning and Storage	25
Troubleshooting Chart	26
Specifications	27
Warranty Information	32

FINDING MODEL NUMBER

This Operator's Manual is an important part of your new Trimmer/Brushcutter. It will help you assemble, prepare and maintain the unit for best performance. Please read and understand what it says.

Before you start assembling your new equipment, please locate the model plate on the equipment and copy the information from it in the space provided below. This information is very important if you need help from our Customer Support Department or an authorized dealer.

- You can locate the model number by looking at the side of the engine housing. A sample model plate is explained below. For future reference, please copy the model number and the serial number of the equipment in the space below

<div style="display: flex; justify-content: space-between;"> Serial Number Model / Parent Part Number </div> <div style="border: 1px solid black; padding: 5px; margin-top: 10px;"> <p>MDL/PPN : _____</p> <p>Ser. No : _____</p> <p style="text-align: center; font-size: small;">MADE IN U.S.A.</p> </div>	<p style="text-align: center;">Copy the model / parent part number here: _____</p> <p style="text-align: center;">Copy the serial number here: _____</p>
--	--

CALLING CUSTOMER SUPPORT

If you have difficulty assembling this product or have any questions regarding the controls, operation or maintenance of this unit, please call the Customer Support Department.



Call **1- (330) 558-7220** or **1- (866) 840-6483** to reach a Customer Support representative. Please have your unit's model number and serial number ready when you call. See previous section to locate this information. You will be asked to enter the serial number in order to process your call .



For more details about your unit, visit our website at www.troybilt.com

RULES FOR SAFE OPERATION

The purpose of safety symbols is to attract your attention to possible dangers. The safety symbols, and their explanations, deserve your careful attention and understanding. The safety warnings do not by themselves eliminate any danger. The instructions or warnings they give are not substitutes for proper accident prevention measures.

SYMBOL	MEANING
	<p>SAFETY ALERT SYMBOL: Indicates danger, warning, or caution. Attention is required in order to avoid serious personal injury. May be used in conjunction with other symbols or pictographs.</p>
<p>NOTE: Advises you of information or instructions vital to the operation or maintenance of the equipment.</p>	

California Proposition 65 Warning:

	<h3>WARNING</h3>	
<p>THE ENGINE EXHAUST FROM THIS PRODUCT CONTAINS CHEMICALS KNOWN TO THE STATE OF CALIFORNIA TO CAUSE CANCER, BIRTH DEFECTS OR OTHER REPRODUCTIVE HARM.</p>		

READ ALL INSTRUCTIONS BEFORE OPERATING

- Read the instructions carefully. Be familiar with the controls and proper use of the unit.
- Do not operate this unit when tired, ill, or under the influence of alcohol, drugs, or medication.
- Children and teens under the age of 15 must not use the unit, except for teens guided by an adult.
- Inspect the unit before use. Replace damaged parts. Check for fuel leaks. Make sure all fasteners are in place and secure. Replace cutting attachment parts that are cracked, chipped, or damaged in any way. Make sure the cutting attachment is properly installed and securely fastened. Be sure the cutting attachment shield is properly attached, and positioned as recommended. Failure to do so can result in personal injury to the operator and bystanders, as well as damage to the unit.
- Use only 0.105 inch (2.667 mm) diameter genuine Troy-Bilt LLC replacement line. Never use metal-reinforced line, wire, or rope, etc. These can break off and become a dangerous projectile.
- Be aware of the risk of injury to the head, hands and feet.
- Clear the area to be cut before each use. Remove all objects such as rocks, broken glass, nails, wire, or string which can be thrown or become entangled in

	<p>DANGER: Failure to obey a safety warning will result in serious injury to yourself or to others. Always follow the safety precautions to reduce the risk of fire, electric shock, and personal injury.</p>
---	--

	<p>WARNING: Failure to obey a safety warning can result in injury to yourself and others. Always follow the safety precautions to reduce the risk of fire, electric shock, and personal injury.</p>
---	--

	<p>CAUTION: Failure to obey a safety warning may result in property damage or personal injury to yourself or to others. Always follow the safety precautions to reduce the risk of fire, electric shock, and personal injury.</p>
---	--

the cutting attachment. Clear the area of children, bystanders, and pets. At a minimum, keep all children, bystanders and pets outside a 50 feet (15 m) radius; there still may be a risk to bystanders from thrown objects. Bystanders should be encouraged to wear eye protection. If you are approached, stop the engine and cutting attachment immediately.

- Squeeze the throttle control and check that it returns automatically to the idle position. Make all adjustments or repairs before using unit.

SAFETY WARNINGS FOR GAS TRIMMERS

WARNING: Gasoline is highly flammable, and its vapors can explode if ignited. Take the following precautions:

- Store fuel only in containers specifically designed and approved for the storage of such materials.
- Always stop the engine and allow it to cool before filling the fuel tank. Never remove the cap of the fuel tank, or add fuel, when the engine is hot. Never operate the unit without the fuel cap securely in place. Loosen the fuel tank cap slowly to relieve any pressure in the tank.
- Add fuel in a clean, well-ventilated area outdoors where there are no sparks or flames. Slowly remove the fuel cap only after stopping engine. Do not smoke while fueling or mixing fuel. Wipe up any spilled fuel from the unit immediately.
- Avoid creating a source of ignition for spilled fuel. Do not start the engine until fuel vapors dissipate.
- Move the unit at least 30 feet (9.1 m) from the fueling source and site before starting the engine. Do not smoke, keep sparks and open flames from the area while adding fuel or operating the unit.

WHILE OPERATING

- Never start or run the unit inside a closed room or building. Breathing exhaust fumes can kill. Operate this unit only in a well ventilated area outdoors.
- Wear safety glasses or goggles that are marked as meeting ANSI Z87.1 standards, and ear/hearing protection when operating this unit. Wear a face or dust mask if the operation is dusty.

RULES FOR SAFE OPERATION

- Wear heavy, long pants, boots, gloves and a long sleeve shirt. Do not wear loose clothing, jewelry, short pants, sandals or go barefoot. Secure hair above shoulder level.
- The cutting attachment shield must always be in place while operating the unit. Do not operate unit without both trimming lines extended, and the proper line installed. Do not extend the trimming line beyond the length of the shield.
- This unit has a clutch. The cutting attachment remains stationary when the engine is idling. If it does not, have the unit adjusted by an authorized service technician.
- Adjust the J-Handle to your size to provide the best grip.
- Be sure the cutting attachment is not in contact with anything before starting the unit.
- Use the unit only in daylight or good artificial light.
- Avoid accidental starting. Be in the starting position whenever pulling the starter rope. The operator and unit must be in a stable position while starting. See Starting/Stopping Instructions.
- Use the right tool. Only use this tool for the purpose intended.
- Do not overreach. Always keep proper footing and balance.
- Always hold the unit with both hands when operating. Keep a firm grip on both the front and rear handle or grips.
- Keep hands, face, and feet at a distance from all moving parts. Do not touch or try to stop the cutting attachment when it is rotating.
- Do not touch the engine, gear housing or muffler. These parts get extremely hot from operation. When turned off they remain hot for a short time.
- Do not operate the engine faster than the speed needed to cut, trim or edge. Do not run the engine at high speed when not cutting.
- Always stop the engine when cutting is delayed or when walking from one cutting location to another.
- If you strike or become entangled with a foreign object, stop the engine immediately and check for damage. Do not operate before repairing damage. Do not operate the unit with loose or damaged parts.
- Stop and switch the engine to off for maintenance, repair, or for changing the cutting attachment or other attachments.
- Use only genuine manufacturer's replacement parts and accessories for this unit. These are available from your authorized service dealer. Use of any non Troy-Bilt LLC parts or accessories could lead to serious injury to the user, or damage to the unit, and void your warranty.
- Keep unit clean of vegetation and other materials. They may become lodged between the cutting attachment and shield.

- To reduce fire hazard, replace faulty muffler and spark arrestor, keep the engine and muffler free from grass, leaves, excessive grease or carbon build up.

WHILE OPERATING WITH CUTTING BLADE

- Read and understand all safety warnings before operating this unit.
 - Always use the shoulder harness when using the brush blade accessory.
 - Keep the J-handle between the operator and cutting attachment or blade at all times.
 - NEVER cut with the cutting blade located over 30 inches (76 cm) or more above the ground level.
 - Blade thrust may occur when the spinning blade contacts an object that it does not immediately cut. Blade thrust can be violent enough to cause the unit and/or operator to be propelled in any direction, and possibly lose control of the unit. Blade thrust can occur without warning if the blade snags, stalls or binds. This is more likely to occur in areas where it is difficult to see the material being cut.
 - For operation with the brush blade, do not cut anything thicker than 1/2 inch or a violent kickback could occur.
 - Do not attempt to touch or stop the blade when it is rotating.
 - A coasting blade can cause injury while it continues to spin after the engine is stopped or the throttle trigger is released. Maintain proper control until the blade has completely stopped rotating.
 - Do not run the unit at high speed when not cutting.
 - If you strike or become entangled with a foreign object, stop the engine immediately and check for damage. Have any damage repaired before attempting further operations. Do not operate unit with a bent, cracked or dull blade. Discard blades that are bent, warped, cracked or broken.
 - Do not sharpen the cutting blade. Sharpening the blade can cause the blade tip to break off while in use. This can result in severe personal injury. Replace the blade.
 - Do not use the cutting blade for edging or as an edger, severe personal injury to yourself or others can occur. Use the cutting blade only for the purpose as described in this manual.
 - Stop the engine IMMEDIATELY if you feel excessive vibration. Vibration is a sign of trouble. Inspect thoroughly for loose nuts, bolts or damage before continuing. Repair or replace affected parts as necessary.
- ## AFTER USE
- Clean cutting blades with a household cleaner to remove any gum buildup. Oil the blade with machine oil to prevent rust.
 - Lock up and store the cutting blade in an appropriate area to protect the blade from unauthorized use or damage.

RULES FOR SAFE OPERATION

OTHER SAFETY WARNINGS

- Never store the unit, with fuel in the tank, inside a building where fumes may reach an open flame or spark.
- Allow the engine to cool before storing or transporting. Be sure to secure the unit while transporting.
- Store the unit in a dry area, locked up or up high to prevent unauthorized use or damage, out of the reach of children.
- Never douse or squirt the unit with water or any other liquid. Keep handles dry, clean and free from debris. Clean after each use, see **Cleaning and Storage** instructions.
- Keep these instructions. Refer to them often and use them to instruct other users. If you loan someone this unit, also loan them these instructions.

SAVE THESE INSTRUCTIONS

SAFETY AND INTERNATIONAL SYMBOLS

This operator's manual describes safety and international symbols and pictographs that may appear on this product. Read the operator's manual for complete safety, assembly, operating and maintenance and repair information.

SYMBOL

MEANING



• SAFETY ALERT SYMBOL

Indicates danger, warning, or caution. May be used in conjunction with other symbols or pictographs.



• WARNING - READ OPERATOR'S MANUAL

Read the Operator's Manual(s) and follow all warnings and safety instructions. Failure to do so can result in serious injury to the operator and/or bystanders.



• FOR SERVICE INFORMATION, CALL:

1-866-840-6483 or
1-330-558-7220



• WEAR EYE AND HEARING PROTECTION

WARNING: Thrown objects and loud noise can cause severe eye injury and hearing loss. Wear eye protection meeting ANSI Z87.1 standards and ear protection when operating this unit.



• KEEP BYSTANDERS AWAY

WARNING: Keep all bystanders, especially children and pets, at least 50 feet (15 m) from the operating area.



• PRIMER BULB

Push primer bulb, fully and slowly, 5 to 7 times.



• UNLEADED FUEL

Always use clean, fresh unleaded fuel.

RULES FOR SAFE OPERATION

SYMBOL

MEANING



- **OIL**

Refer to operator's manual for the proper type of oil.



- **THROWN OBJECTS AND ROTATING CUTTER CAN CAUSE SEVERE INJURY**

WARNING: Do not operate without the cutting attachment shield in place. Keep away from the rotating cutting attachment.



- **ON/OFF STOP CONTROL**

ON / START / RUN



- **ON/OFF STOP CONTROL**

OFF OR STOP



- **HOT SURFACE WARNING**

Do not touch a hot muffler, gear housing or cylinder. You may get burned. These parts get extremely hot from operation. When turned off they remain hot for a short time.



- **SHARP BLADE**

WARNING: Sharp blade on cutting attachment shield. To prevent serious injury, do not touch line cutting blade.



- **CHOKER CONTROL**

A • **FULL** choke position.
B • **PARTIAL** choke position.
C • **RUN** position.



- **BRUSHCUTTERS • Replace dull blade.**

Do not sharpen the cutting blade. Sharpening the blade can cause the blade tip to break off while in use. This can result in severe personal injury.



- **TRIMMER/BRUSHCUTTER SAFETY**

WARNING: Thrown objects and rotating cutter can cause severe injury. Keep bystanders, especially children and pets, at least 50 feet (15 m.) away from the cutting area. The cutting attachment shield must be used when using the trimmer cutting attachment.



WARNING: The operation of any power tool can cause foreign objects to be thrown into your eyes. This can lead to severe eye damage. Before commencing power tool operation, always wear safety glasses or goggles that are marked as meeting ANSI Z87.1 standards, and a full face shield when needed.

RULES FOR SAFE OPERATION

KNOW YOUR UNIT

APPLICATIONS

As a trimmer:

- Cutting grass and light weeds.
- Edging.
- Decorative trimming around trees, fences, etc.

As a brushcutter;

- Cutting weeds and light bush of up to 1/2 inch in diameter.

Other optional accessories may be used with the TB490BC. See list of add-ons on page 14.

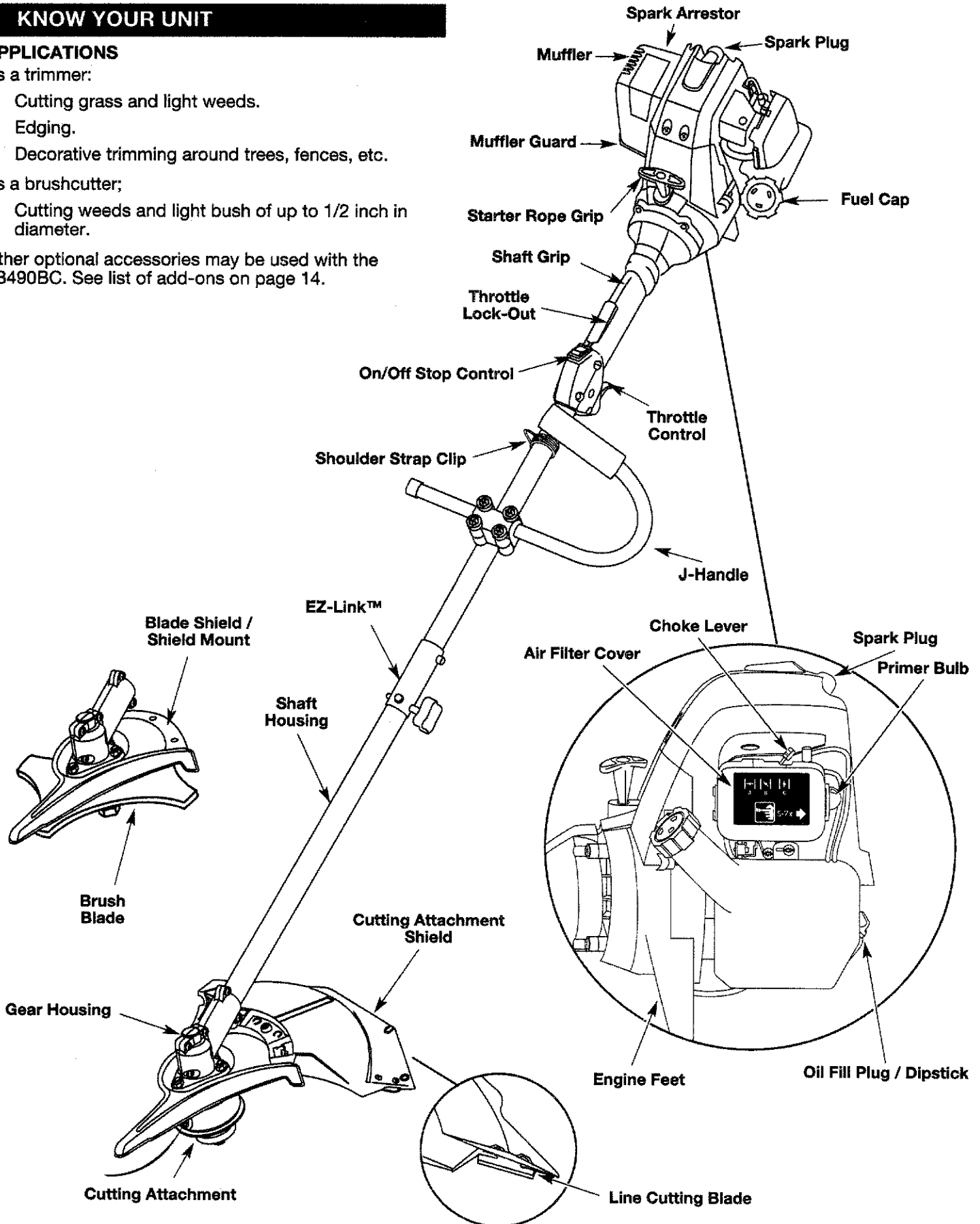

ASSEMBLY INSTRUCTIONS

INSTALLING AND ADJUSTING THE J-HANDLE

1. Place the J-handle between the top and middle clamp pieces (Fig. 1).

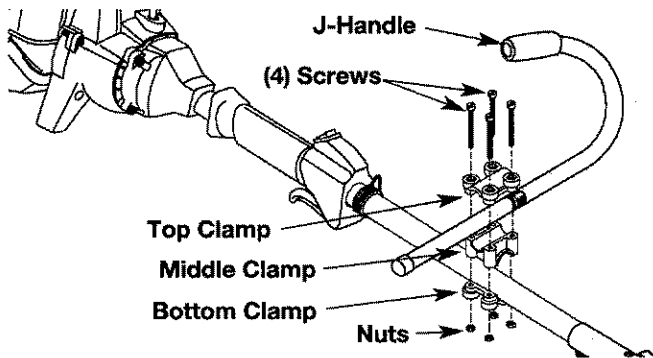

Fig. 1

2. While holding the three pieces together, install the four (4) screws through the top clamp and into middle clamp.

NOTE: The holes in the top and middle clamp will line up only when assembled correctly.

3. Place the clamps and J-handle over the shaft housing and onto the bottom clamp.
4. Hold each hex nut in the bottom clamp recess with a finger. Start screws with a large Phillips screwdriver. Do not tighten until you make the handle adjustment.
5. Slide the J-handle in or out until the arrow/white line on the decal touches the clamp assembly (Fig. 2).

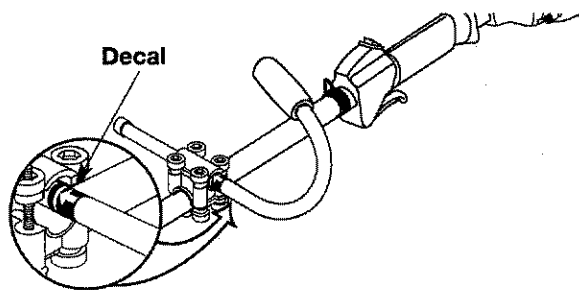

Fig. 2



Fig. 3

6. While holding the unit in the operating position (Fig. 3), position the J-handle to the location that provides you the best grip.
7. Tighten the clamp screws evenly, until the J-handle is secure.

INSTALLING THE HARNESS



WARNING: Always use the shoulder harness when using the cutting blade to avoid serious personal injury.

1. Push the strap through the center of the buckle.
2. Pull the strap over the cross bar and down through the slot in the buckle (Fig. 4).

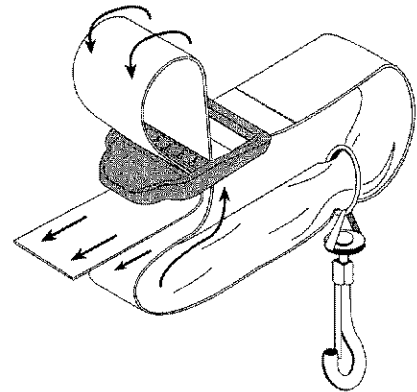

Fig. 4

3. Put the harness on over head and onto shoulder. Snap it on to the support fitting (Fig. 5).

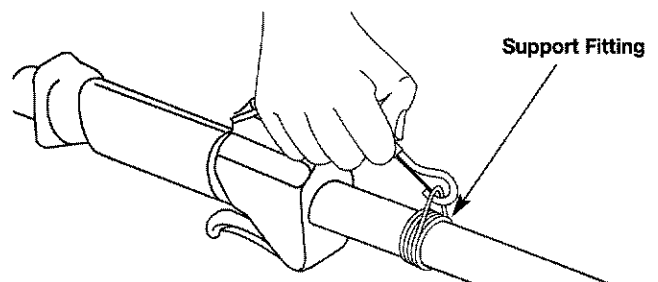

Fig. 5

4. Adjust length to fit the operator's size. Pull tab to lengthen, pull strap to shorten (Fig 6).

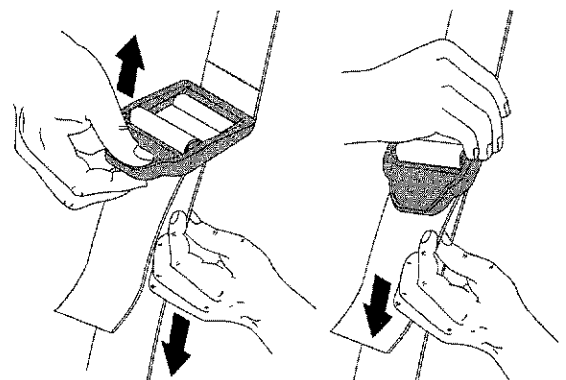

Fig. 6

ASSEMBLY INSTRUCTIONS

REMOVING AND INSTALLING CUTTING ATTACHMENT SHIELD

Remove the cutting attachment shield when using the unit as a brushcutter.



WARNING: The cutting attachment shield should NOT be installed when operating the unit with a blade. Remove the cutting attachment shield before removing or installing the blade.

Remove the cutting attachment shield from the shield mount by removing the three (3) screws with a flat blade screwdriver (Fig. 7). Store parts for future use.

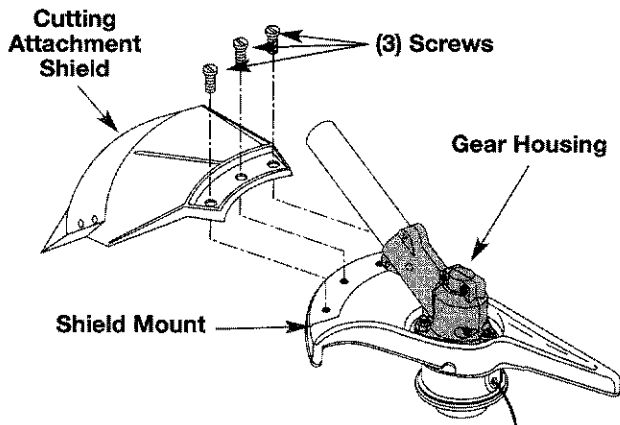

Fig. 7

Install the cutting attachment shield when using the unit as a grass trimmer.



WARNING: To avoid serious personal injury, the cutting attachment shield SHALL be in place at all times while operating the unit as a grass trimmer.

Install the cutting attachment shield on the shield mount by inserting the three (3) screws into the shield mount. Tighten securely with a flat blade screwdriver (Fig. 7).

REMOVE THE CUTTING ATTACHMENT AND INSTALL THE CUTTING BLADE

NOTE: To make removing or installing the cutting blade or cutting attachment easier, place the unit on the ground or on a work bench.

Remove the Cutting Attachment Shield

See Removing and Installing Cutting Attachment Shield.

Remove the Cutting Attachment



WARNING: The gear housing gets hot with use and can result in injury to the operator. When the unit is turned off it remains hot for a short time. Do not touch the gear housing until it has cooled.

1. Align the shaft bushing hole with the locking rod slot and insert the locking rod into the shaft bushing hole (Fig. 8).

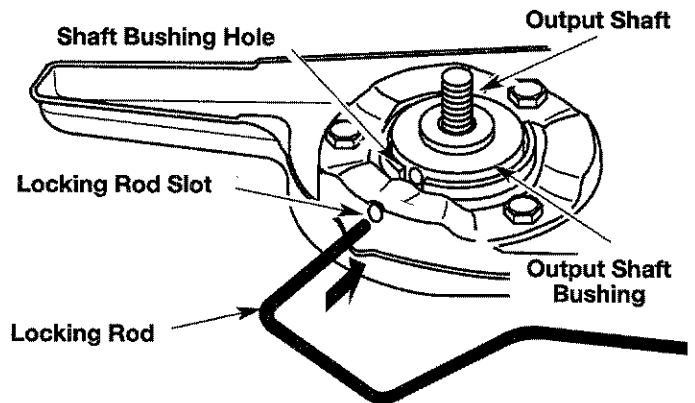

Fig. 8

2. Hold the locking rod in place by grasping it next to the boom of the unit (Fig. 9).
3. While holding the locking rod, remove the cutting attachment by turning it clockwise off of the output shaft (Fig. 10). Store the cutting attachment for future use.

NOTE: The blade retainer under the cutting attachment will be used when installing the cutting blade.

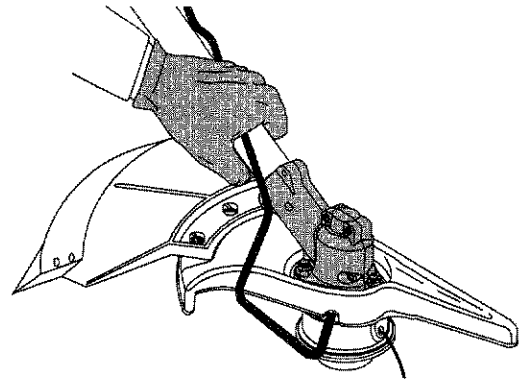

Fig. 9

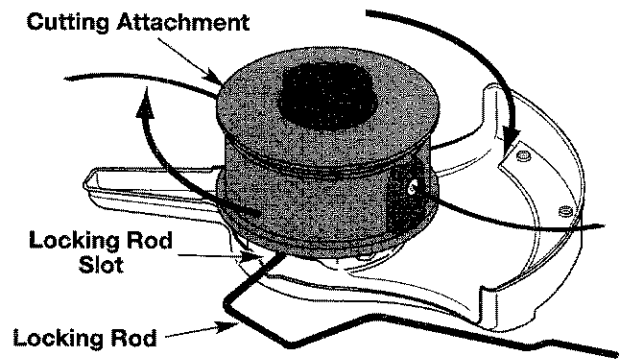

Fig. 10

ASSEMBLY INSTRUCTIONS

Install the Cutting Blade



WARNING: To avoid serious personal injury, always wear gloves while handling or installing the blade.

- Place the cutting blade on the output shaft bushing (Fig. 11).
- Make sure that the cutting blade is centered on the pilot step and sitting flat against the output shaft bushing (Fig. 12).



WARNING: If the cutting blade is off-center, the unit will vibrate, and the blade may fly off, which can cause serious personal injury.

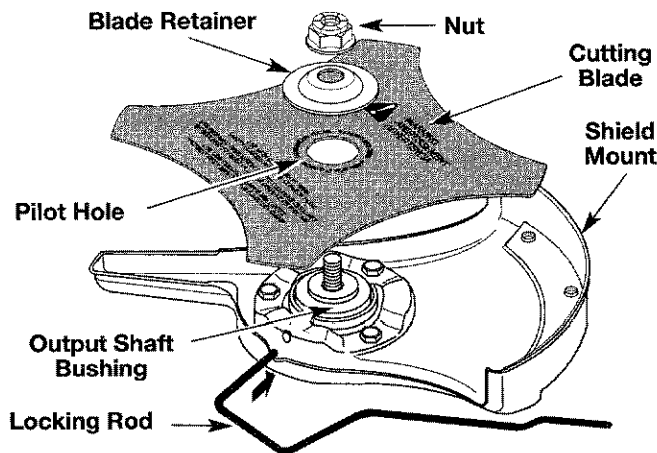

Fig. 11

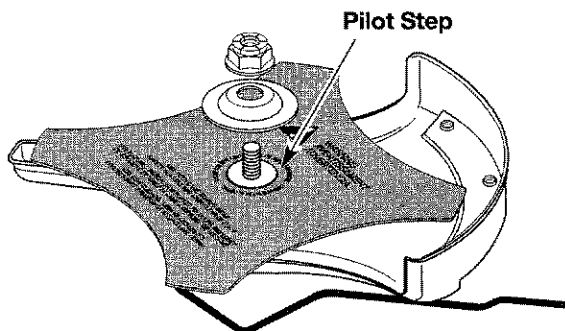

Fig. 12

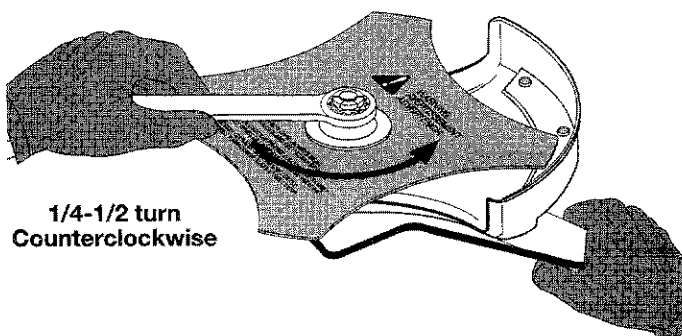

Fig. 13

- Align the shaft bushing hole with the locking rod slot and insert the locking rod into the bushing hole (Fig. 8, Pg. 9).
- Put the blade retainer and nut on the output shaft. Make sure that the blade is installed correctly.
- Tighten nut counterclockwise against the blade while holding the locking rod. (Fig. 13)
 - If using a torque wrench and an 5/8 inch socket tighten to: **325 - 335 in•lb, 27 - 28 ft.•lb, 37 - 38 N•m.**
 - Without a torque wrench, use a 5/8 inch closed-end or socket wrench, turning the nut until the blade retainer is snug against the shaft bushing. Make sure that the blade is installed correctly, then rotate the nut an additional 1/4 to 1/2 turn counterclockwise (Fig. 13).
- Remove the locking rod from the locking rod slot.



WARNING: To avoid serious personal injury or damage to the unit, do not start or operate this unit with the locking rod in the locking rod slot.



WARNING: Do not sharpen the cutting blade. Sharpening the blade can cause the blade tip to break off while in use. This can result in severe personal injury. Replace the blade.

REMOVE THE CUTTING BLADE AND INSTALL THE CUTTING ATTACHMENT

Remove the Cutting Blade



WARNING: To avoid serious personal injury, always wear gloves while handling or installing the blade.

- Align the shaft bushing hole with the locking rod slot and insert the locking rod into the bushing hole (Fig. 8, Pg. 9).
- Hold the locking rod in place by grasping it next to the boom of the unit (Fig. 14).

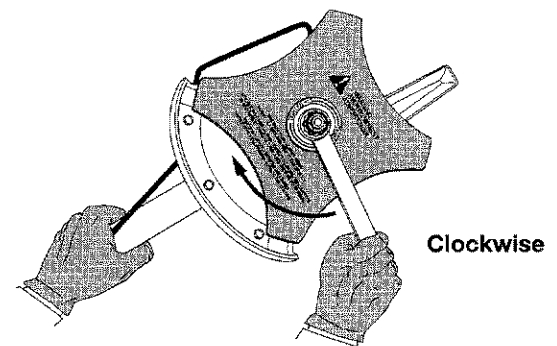

Fig. 14

ASSEMBLY INSTRUCTIONS

3. While holding the locking rod, loosen the nut on the blade by turning it clockwise with a 5/8 inch closed-end or socket wrench (Fig. 14).
4. Remove the nut, blade retainer, and blade. Store the nut and blade together for future use in a secure place. Store out of reach of children.

Install the Cutting Attachment

5. Align the shaft bushing hole with the locking rod slot and insert the locking rod into the shaft bushing hole (Fig. 8, Pg. 9). Place the blade retainer on the output shaft with the flat surface against the output shaft bushing as shown in Fig. 15. Screw the cutting attachment counterclockwise onto the output shaft. Tighten securely.

NOTE: The blade retainer must be installed on the output shaft in the position shown for the cutting attachment to work correctly.

6. Remove the locking rod.
7. Install the cutting attachment shield. See Removing and Installing Cutting Attachment Shield, Pg. 9.

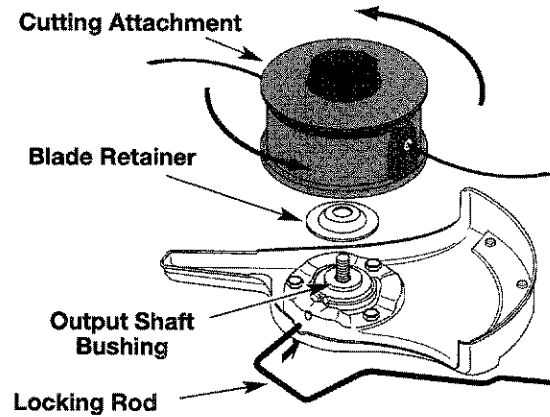

Fig. 15



WARNING: To avoid serious personal injury, the cutting attachment shield **SHALL** be in place at all times while operating the unit as a grass trimmer.

OIL AND FUEL INFORMATION



DANGER: OVERFILLING OIL CRANKCASE MAY CAUSE SERIOUS PERSONAL INJURY! The importance of checking and maintaining the proper oil level in the crank case cannot be overemphasized. Check oil before each use and change as needed. **See Changing the Oil.**

RECOMMENDED OIL TYPE

Using the proper type and weight of oil in the crankcase is extremely important. Check the oil before each use and change the oil regularly. Failure to use the correct oil, or using dirty oil, can cause premature engine wear and failure.

Use a high-quality SAE 30 weight oil of API (American Petroleum Institute) service class SF, SG, SH.

ADDING OIL TO CRANKCASE – INITIAL USE

NOTE: This unit is shipped without being filled with oil. In order to avoid damage to the unit, put oil in the crankcase before attempting to start unit.

Your unit is supplied with one 3.4 fluid oz. (100 ml.) bottle of SAE 30 SF, SG, SH oil (Fig. 16).

NOTE: Save the bottle to measure the correct amount for future oil changes. See **Changing the Oil.**

1. Unscrew the top of the bottle of oil and remove the paper seal covering the opening. Replace top. Cut the tip off the funnel spout (Fig. 16).

2. Place the unit on a flat level surface.
3. Remove the oil plug / dipstick from the crankcase (Fig. 17).

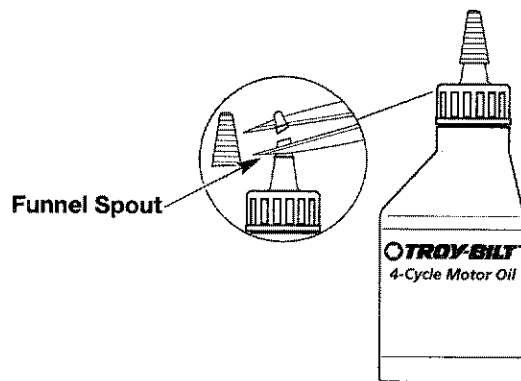

Fig. 16

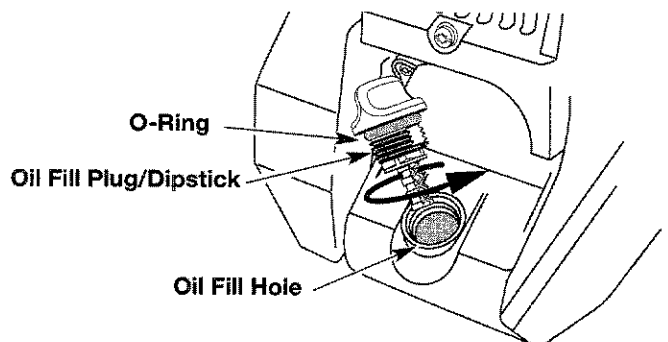

Fig. 17

OIL AND FUEL INFORMATION

4. Pour the entire bottle of oil into the oil fill hole (Fig. 18).

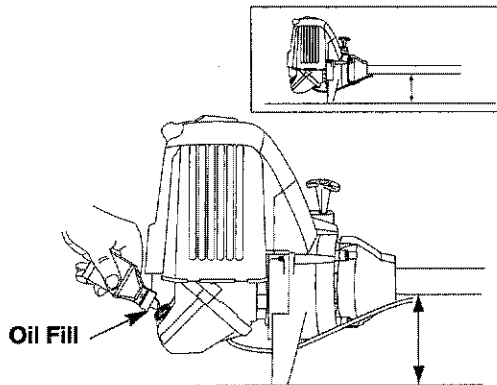

Fig. 18

NOTE: Never add oil to the fuel or fuel tank.

5. Wipe up any oil that may have spilled and reinstall the oil fill plug / dipstick.

RECOMMENDED FUEL TYPE

Old fuel is the primary reason for the unit not running properly. Be sure to use fresh, clean, unleaded Gasoline.



NOTE: This is a four cycle engine. In order to avoid damage to the unit, **do not mix oil with Gasoline.**

Definition of Blended Fuels

Today's fuels are often a blend of gasoline and oxygenates such as ethanol, methanol or MTBE (ether). Alcohol-blended fuel absorbs water. As little as 1% water in the fuel can make fuel and oil separate or form acids when stored. Use fresh fuel (less than 60 days old), when using alcohol-blended fuel.

Using Blended Fuels

If you choose to use a blended fuel, or its use is unavoidable, follow recommended precautions.

- Always use fresh unleaded gasoline
- Use the fuel additive STA-BIL® or an equivalent.
- Drain tank and run the engine dry before storing unit.

Using Fuel Additives

The use of fuel additives, such as STA-BIL® Gas Stabilizer or an equivalent, will inhibit corrosion and minimize the formation of gum deposits. Using a fuel additive can keep fuel from forming harmful deposits in the carburetor for up to six (6) months. Add 0.8 oz. (23 ml.) of fuel additive per gallon of fuel according to the instructions on the container. **NEVER** add fuel additives directly to the unit's gas tank.

FUELING UNIT



WARNING: Gasoline is extremely flammable and its vapors can explode if ignited. To avoid serious personal injury, always stop the engine and allow it to cool before filling the fuel tank. Do not smoke while filling the tank. Keep sparks and open flames away from the area.

1. Remove fuel cap (Fig. 19).



WARNING: Remove fuel cap slowly to avoid injury from gasoline spray.

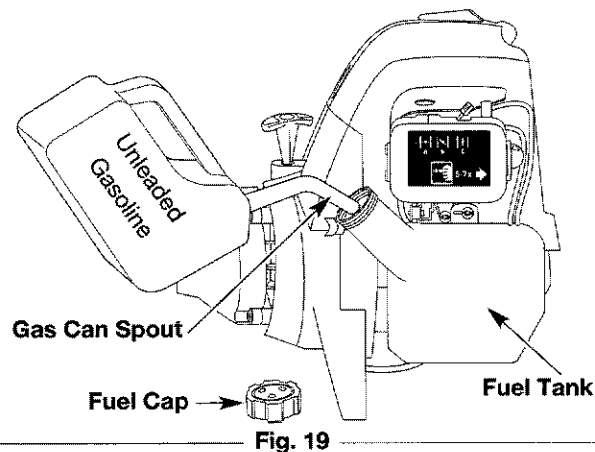

Fig. 19

2. Place spout of gas container into the fill hole on the fuel tank (Fig. 19) and fill tank.



WARNING: Add gasoline in a clean, well ventilated area outdoors. Avoid creating a source of ignition for spilt fuel.

NOTE: Do not overfill tank.

3. Wipe up any gasoline that may have spilled
4. Reinstall the fuel cap.



WARNING: Never operate the unit without the fuel cap securely in place.

5. Move the unit at least 30 ft. (9.1 m) from the fueling source and site before starting the engine.

NOTE: Dispose of the old gasoline in accordance to Federal, State, and Local regulations.

STARTING/STOPPING INSTRUCTIONS

STARTING INSTRUCTIONS

Cold Start - First Start of the Day or Engine Ran Out of Fuel



WARNING: Operate this unit only in a well ventilated area outdoors. Carbon monoxide exhaust fumes can be lethal in a confined area.

1. Check oil level in crankcase. See **Checking the Oil Level** Pg. 19.
2. Fill the fuel tank with fresh, clean, unleaded gasoline (see page 12).
3. Put the Start/Stop Engine Control in the **START (I)** position (Fig. 20).

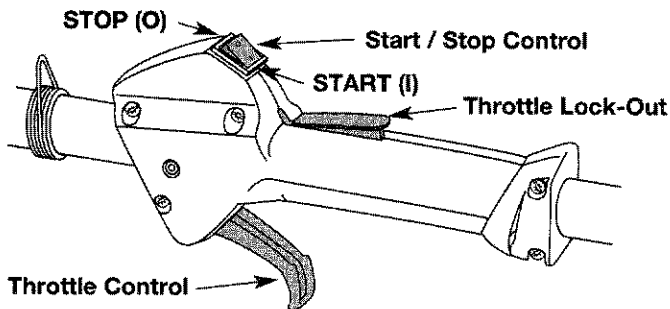

Fig. 20

4. Place the choke lever in the **FULL** choke (A) |←| position (Fig. 21).

NOTE: Slide the choke lever directly above the appropriate symbol on air filter cover decal (Fig. 21).

5. Fully press and release the primer bulb slowly 7 times. Gasoline should be felt and visible in the bulb (Fig. 21). If gasoline has not entered the bulb, press three more times, or until it does.

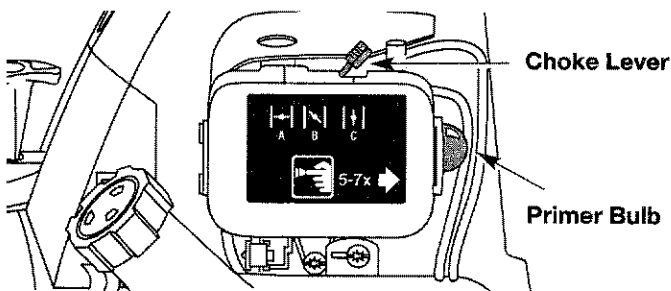

Fig. 21

6. While pressing the throttle lock-out, squeeze the throttle control to the wide open (full throttle) position (Fig. 20).
7. With the unit in the starting position (Fig. 21) pull the starter rope briskly 5 times in the **FULL** choke (A) |←| position. If the engine attempts to run before the fifth pull, proceed to step 8.
8. Move the choke lever to the **PARTIAL** (B) |↘| position (Fig. 21).

NOTE: The engine will not run in the **FULL** choke (A) |←| position.

9. Pull the starter rope 1 to 3 pulls until the engine starts. Run for 15-30 seconds. If the unit fails to start return to step 7.
10. Move the choke lever to the **RUN** (C) |↑| position and run at full throttle for 30 seconds.



WARNING: Avoid accidental starting. Be in the starting position whenever pulling the starting rope. To avoid serious personal injury, the operator and unit must be in a stable position while starting.

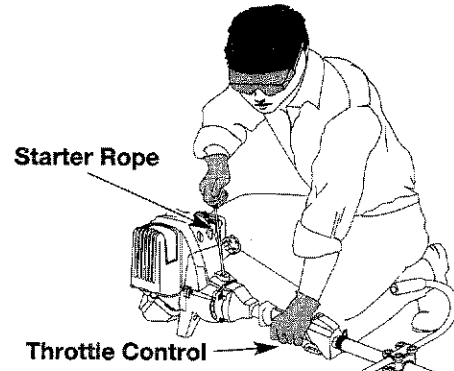

Fig. 22

11. Release the throttle control to the idle position and begin operation.

NOTE: If the engine does not start using these procedures, repeat steps 5 through 11 using **TWO** (2) pulls in the **FULL** choke (A) |←| position.

Engine Re-Start - Warm Engine With Fuel

1. Put the Start/Stop Engine Control in the **START** (I) position (Fig. 20).
2. Move the choke lever to the **PARTIAL** (B) |↘| position (Fig. 21).
3. Fully press and release the primer bulb slowly 7 times. Gasoline should be felt and visible in the bulb (Fig. 21). If gasoline has not entered the bulb, press three more times, or until it does.
4. While pressing the throttle lock-out, squeeze the throttle control to the wide open (full throttle) position (Fig. 20).
5. With the unit in the starting position (Fig. 22), pull the starter rope briskly until the engine starts.
6. When the engine starts, move the choke lever to the **RUN** (C) |↑| position, and run at full throttle for 30 seconds.

NOTE: If the engine does not start using the **Engine Re-start** procedures, revert to the **Cold Start** procedures.

NOTE: 4-stroke engines, like cars, are able to start in the idle position. As an alternate method, you may want to start your unit in the idle position when the unit is warm. With the Start/Stop control in the **START** position, pull the starter rope briskly. When the engine starts, run at full throttle for 30 seconds. If the unit fails to start or dies, revert to the **Engine Re-Start** procedure.

STARTING/STOPPING INSTRUCTIONS

STOPPING INSTRUCTIONS

1. Release your hand from the throttle control (Fig. 22). Allow the engine to idle.
2. To stop the engine, put the Start/Stop Engine Control in the **STOP [O]** position (Fig. 20).

OPERATING INSTRUCTIONS

OPERATING THE EZ-LINK™ SYSTEM

The EZ-Link™ system enables the use of these optional add-ons.

Blower/Vacuum	BV720r
Cultivator	GC720r
Edger	LE720r
Hedge Trimmer	HS720r
Snow Thrower	ST720r
Straight Shaft Trimmer	SS725r
Sweeper/Blower	SB720r
Tree Pruner	TP720r
Turbo Blower	TB720r



WARNING: Read and understand operator's manual for add-on prior to operation.

Removing the Cutting Attachment or Add-Ons:

1. Turn the knob counterclockwise to loosen (Fig. 23).
2. Press and hold the release button (Fig. 23).
3. While firmly holding the upper shaft housing, pull the cutting attachment or add-on straight out of the EZ-Link™ coupler (Fig. 24).

Installing the Cutting Attachment or Add-Ons:



WARNING: To avoid serious personal injury and damage to the unit, shut unit off before removing or installing add-ons.

NOTE: To make installing or removing the add-on easier, place the unit on the ground or on a work bench.

1. Turn knob counterclockwise to loosen (Fig. 23).

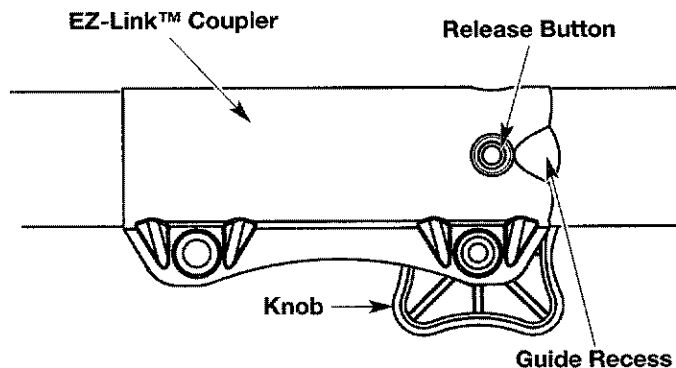

Fig. 23

2. While firmly holding the add-on, push it straight into the EZ-Link™ coupler (Fig. 24).

NOTE: Aligning the release button with the guide recess will help installation (Fig. 23).

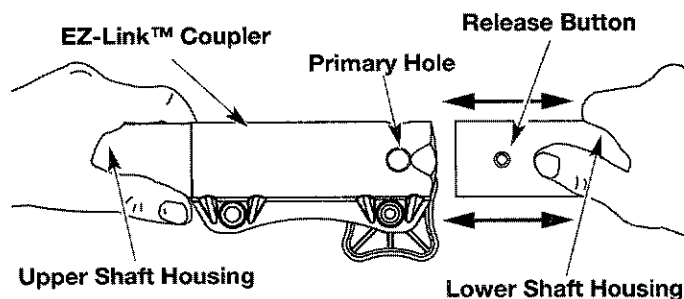

Fig. 24

3. Turn the knob clockwise to tighten (Fig. 25).



CAUTION: Lock the release button in the primary hole and securely tighten the knob before operating this unit.

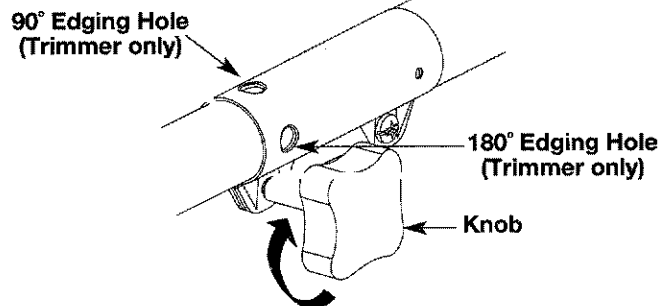

Fig. 25



CAUTION: The cutting attachment and add-ons with the EZ-Link™ system are to be used in the primary hole unless stated otherwise in the specific add-ons operator's manual. Using the wrong hole could lead to personal injury, or damage to the unit.

For edging when using the line head cutting attachment with EZ-Link™ models, lock the release button of the cutting attachment into the **90° edging hole** or the **180° edging hole** (Fig. 25).



WARNING: Do not use the cutting blade for edging or as an edger, severe personal injury to yourself or others can occur.

OPERATING INSTRUCTIONS

HOLDING THE TRIMMER



WARNING: Always wear eye, hearing, foot, body protection and strap to reduce the risk of injury when operating this unit.

Before operating the unit, stand in the operating position (Fig. 26). Check for the following:

- The operator is wearing eye protection and proper clothing.
- The right arm is slightly bent, and the hand is holding the shaft grip.
- The left arm is straight, and the hand is holding the J-handle.
- The unit is at waist level.
- The cutting attachment is parallel to the ground and easily contacts the vegetation to be cut without the operator having to bend over.



Fig. 26

ADJUSTING TRIMMING LINE LENGTH

The Bump Head™ cutting attachment allows you to release trimming line without stopping the engine. To release more line, lightly tap the cutting attachment on the ground (Fig. 27) while operating the trimmer at high speed.

NOTE: Always keep the trimming line fully extended. Line release becomes more difficult as cutting line becomes shorter

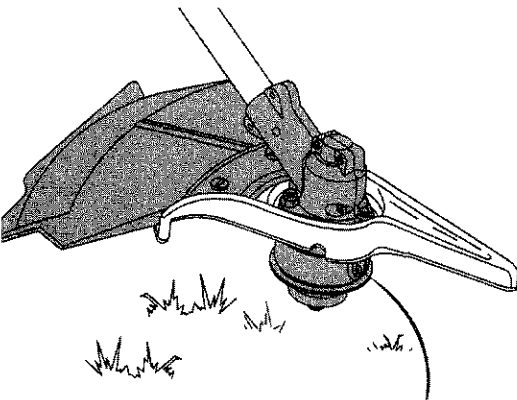

Fig. 27

Each time the head is bumped, about 1 inch (25.4 mm.) of trimming line is released. A blade in the cutting attachment shield will cut the line to the proper length if excess line is released.

For best results, tap the Bump Head™ on bare ground or hard soil. If line release is attempted in tall grass, the engine may stall. Always keep the trimming line fully extended. Line release becomes more difficult as the cutting line becomes shorter.

NOTE: Do not rest the Bump Head™ on the ground while the unit is running .



CAUTION: Do not remove or alter the line cutting blade assembly. Excessive line length will make the clutch overheat. This may lead to serious personal injury or damage to the unit.

Some line breakage will occur from:

- Entanglement with foreign matter
- Normal line fatigue
- Attempting to cut thick, stalky weeds
- Forcing the line into objects such as walls or fence posts

TIPS FOR BEST TRIMMING RESULTS

- Keep the cutting attachment parallel to the ground.
- Do not force the cutting attachment. Allow the tip of the line to do the cutting, especially along walls. Cutting with more than the tip will reduce cutting efficiency and may overload the engine.
- Cut grass over 8 inches (200 mm) by working from top to bottom in small increments to avoid premature line wear or engine drag.
- Cut from left to right whenever possible. Cutting to the right improves the unit's cutting efficiency. Clippings are thrown away from the operator.
- Slowly move the trimmer into and out of the cutting area at the desired height. Move either in a forward-backward or side-to-side motion. Cutting shorter lengths produces the best results.
- Trim only when grass and weeds are dry.
- The life of your cutting line is dependent upon;
 - Following the previous trimming techniques
 - What vegetation is being cut
 - Where it's being cut

For example, the line will wear faster when trimming against a foundation wall as opposed to trimming around a tree.

OPERATING INSTRUCTIONS

DECORATIVE TRIMMING

Decorative trimming is accomplished by removing all vegetation around trees, posts, fences, etc.

Rotate the whole unit so that the cutting attachment is at a 30° angle to the ground (Fig. 28).

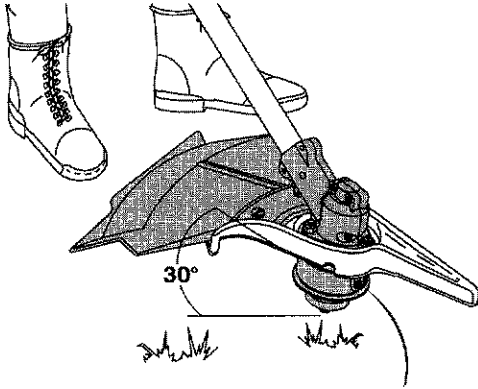

Fig. 28

USING THE CUTTING BLADE



WARNING: Always wear eye, hearing, foot, body protection and the strap to reduce the risk of injury when operating this unit.



WARNING: Do not use the cutting blade for edging or as an edger, severe personal injury to yourself or others can occur.

Before operating the unit with the cutting blade stand in the operating position (Fig. 29).

Cutting Blade Operating Tips:

To establish a rhythmic cutting procedure:

- Plant feet firmly, comfortably apart.
- Bring the engine to full throttle before entering the material to be cut. The blade has maximum cutting power at full throttle and is less likely to bind, stall, or cause blade thrust, which can result in serious personal injury to the operator or others.



WARNING: Blade thrust may occur when the spinning blade contacts an object that it does not immediately cut. Blade thrust can be violent enough to cause the unit and/or operator to be propelled in any direction, and possibly lose control of the unit. Blade thrust can occur without warning if the blade snags, stalls or binds. This is more likely to occur in areas where it is difficult to see the material being cut.

- Cut while swinging the upper part of your body from right to left.
- Always release the throttle trigger and allow the engine to return to idle speed when not cutting.
- When done always unstrap unit from harness before taking harness off.



WARNING: The blade continues to spin after the engine is turned off. The coasting blade can seriously cut you if accidentally touched.

- Swing the unit in the same direction as the blade spins, which increases the cutting action.
- Move forward to the next area to be cut after the return swing and plant feet again.
- The cutting blade is designed with a second cutting edge, which can be used by removing the blade, turning it upside down, and reinstalling it.



WARNING: Do not sharpen the cutting blade. Sharpening the blade can cause the blade tip to break off while in use. This can result in severe personal injury to yourself or others. Replace the blade.

To reduce the chance of material wrapping around the blade, follow these steps:

- Cut at full throttle.
- Swing the unit into material to be cut from your right to your left (Fig. 30).
- Avoid the material just cut as you make the return swing.



WARNING: Do not clear away cut material with the engine running or blade turning. To avoid serious personal injury, turn off engine. Allow the blade to stop before removing materials wrapped around the blade shaft.



Fig. 29

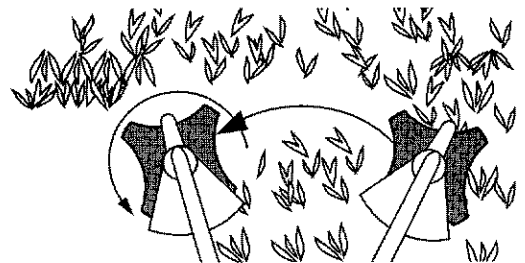

Fig. 30

MAINTENANCE AND REPAIR INSTRUCTIONS

NOTE: Some maintenance procedures may require special tools or skills. If you are unsure about these procedures take your unit to an authorized service dealer.

MAINTENANCE SCHEDULE

These required maintenance procedures should be performed at the frequency stated in the table. They should also be included as part of any seasonal tune-up.

FREQUENCY	MAINTENANCE REQUIRED	REFER TO:
Before Starting Engine	Fill fuel tank with fresh fuel Check oil	Page 12 Page 19
Every 10 Hours	Clean and re-oil air filter.	Page 21
1st Change at 10 Hours Every 25 Hours there after Every 25 Hours	Change oil Change oil Clean Spark Arrestor	Page 19 Page 19 Page 24
10 hours on new engine Every 25 Hours Every 25 Hours	Check rocker arm to valve clearance and adjust as required Check rocker arm to valve clearance and adjust as required Check spark plug condition and gap	Page 23 Page 23 Page 24



WARNING: To prevent serious injury, never do maintenance or repairs with unit running. Always do maintenance and repairs on a cool unit. Disconnect spark plug wire to ensure the unit will not start.

LINE INSTALLATION

This section covers both SplitLine™ and standard single line installation.

Always use genuine Troy-Bilt™ 0.105 in. (2.667 mm) replacement line. Line other than specified may make the engine overheat or fail.



WARNING: Never use metal-reinforced line, wire, chain, or rope, etc. These can break off and become dangerous projectiles.

There are two methods to replace the trimming line.

- Wind the inner reel with new line
- Install a prewound inner reel

Winding the Existing Inner Reel

1. Hold the outer spool with one hand and unscrew the Bump Knob clockwise (Fig. 31). Inspect the bolt inside the bump knob to make sure it moves freely. Replace the bump knob if damaged.
2. Remove the inner reel from the outer spool (Fig. 31).
3. Remove spring from the inner reel (Fig. 31).

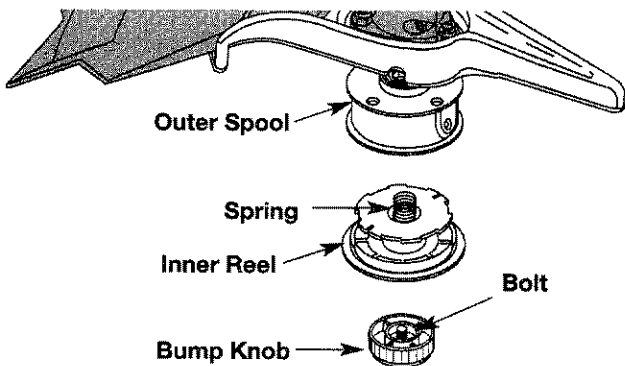

Fig. 31

4. Use a clean cloth to clean the the inner reel, spring, shaft, and inner surface of the outer spool (Fig. 32).
5. Check the indexing teeth on the inner reel and outer spool for wear (Fig. 33). If necessary, remove burrs or replace the reel and spool.

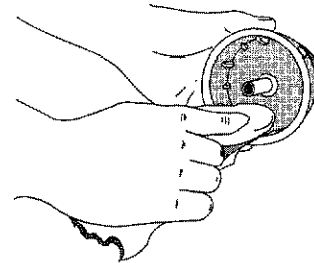

Fig. 32

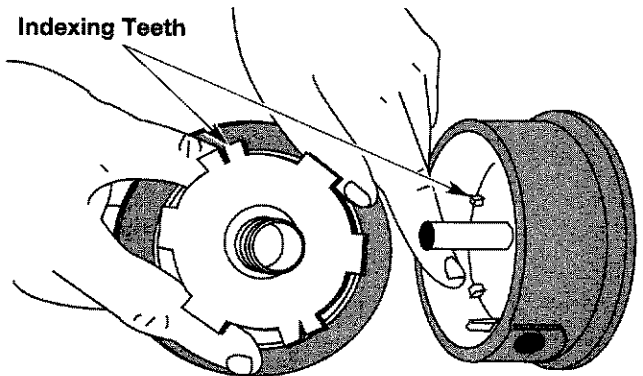

Fig. 33

NOTE: SplitLine™ can only be used with the inner reel with the slotted holes. Single line can be used on either type of inner reel. Use Figure 30 to identify the inner reel you have.

NOTE: Always use the correct line length when installing trimming line on the unit. The line may not release properly if the line is too long.

MAINTENANCE AND REPAIR INSTRUCTIONS

For Use with Single Line ONLY

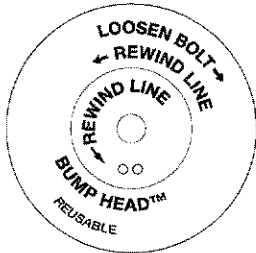

For Use with SplitLine™ or Single Line

Slotted Holes

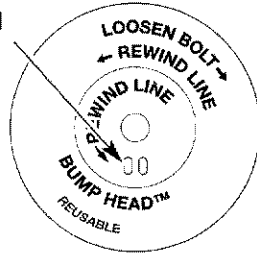

Fig. 34

Single Line Installation

Go To Step 8 for SplitLine™ Installation

- Take approximately 30 feet (9.14 m) of new trimming line, loop it into two equal lengths. Insert each end of the line through one of the two holes in the inner reel (Fig. 35). Pull the line through the inner reel so that the loop is as small as possible.

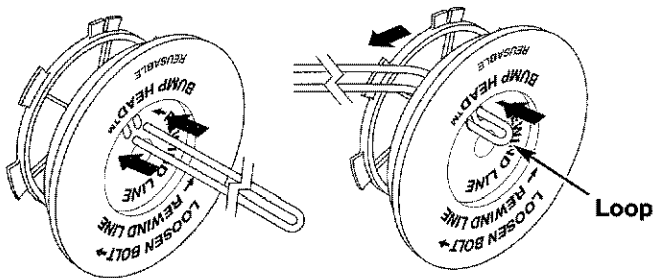

Fig. 35

- Wind the lines in tight even layers, onto the reel (Fig. 36). Wind the line in the direction indicated on the inner reel. Place your index finger between the two lines to stop the lines from overlapping. Do not overlap the ends of the line. Proceed to step 11.

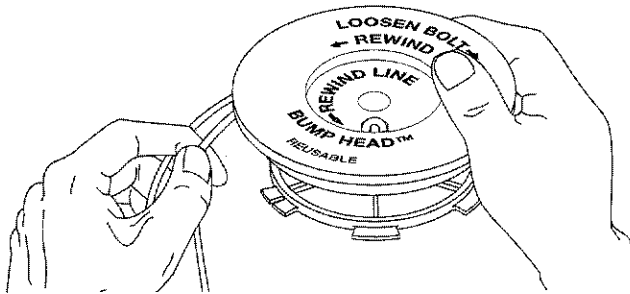

Fig. 36

SplitLine™ Installation

- Take approximately 15 feet (4.57 m) of new trimming line. Insert one end of the line through one of the two holes in the inner reel (Fig. 37). Pull the line through the inner reel until only about 4 inches is left out.
- Insert the end of the line into the open hole in the inner reel and pull the line tight to make the loop as small as possible (Fig. 37).

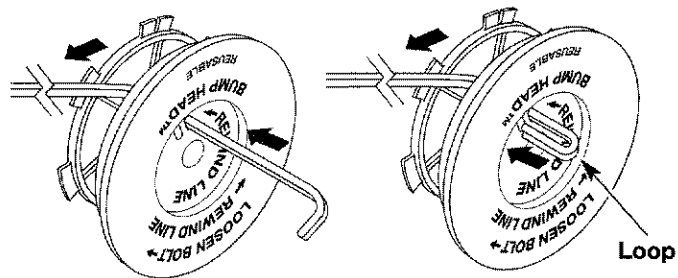

Fig. 37

- Before winding, split the line back about 6 inches.
- Wind the line in tight even layers in the direction indicated on the inner reel.

NOTE: Failure to wind the line in the direction indicated will cause the cutting attachment to operate incorrectly.

- Insert the ends of the line into the two holding slots (Fig. 38).

- Insert the ends of the line through the eyelets in the outer spool and place inner reel with spring inside the outer spool (Fig. 39). Push the inner reel and outer spool together. While holding the inner reel and outer spool, grasp the ends and pull firmly to release the line from the holding slots in the reel.

NOTE: The spring must be assembled on the inner reel before reassembling the cutting attachment.

- Hold the inner reel in place and install the bump knob by turning counterclockwise. Tighten securely.

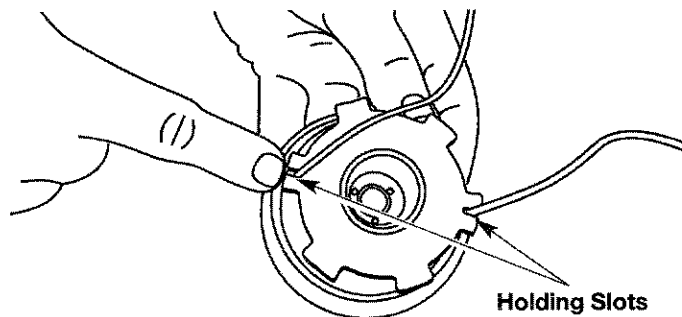

Fig. 38

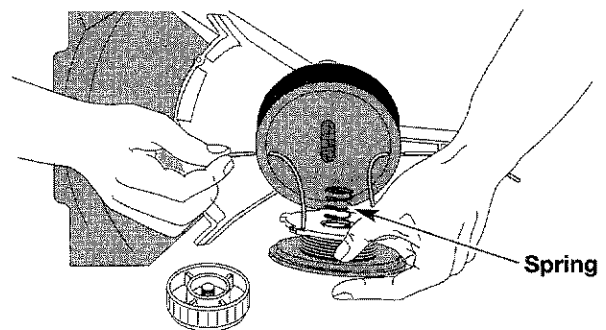

Fig. 39

MAINTENANCE AND REPAIR INSTRUCTIONS

INSTALLING A PREWOUND REEL

1. Hold the outer spool with one hand and unscrew the bump knob clockwise (Fig. 15, Pg. 11). Inspect the bolt inside the bump knob to make sure it moves freely. Replace the bump knob if damaged.
 2. Remove the old inner reel from the outer spool (Fig. 31).
 3. Remove the spring from the old inner reel (Fig. 31).
 4. Place the spring in the new inner reel.
- NOTE:** The spring must be assembled on the inner reel before reassembling the cutting attachment.
5. Insert the ends of the line through the eyelets in the outer spool (Fig. 39, Pg. 18).
 6. Place the new inner reel inside the outer spool. Push the inner reel and outer spool together. While holding the inner reel and outer spool, grasp the ends and pull firmly to release the line from the holding slots in the spool.
 7. Hold the inner reel in place and install the bump knob by turning counterclockwise. Tighten securely.

Replacement Parts:

See Accessories / Replacement Parts.

CHECKING THE OIL LEVEL

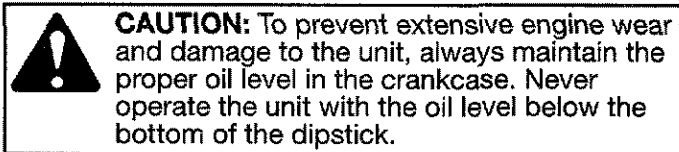

The importance of checking and maintaining the proper oil level in the crankcase cannot be overemphasized. Check oil before each use:

1. Stop engine and allow oil to drain into the crankcase.
2. Place the unit on a flat, level surface to get a proper oil level reading.
3. Keep dirt, grass clippings, etc., out of the engine. Clean the area around the oil fill plug/dipstick before removing it.
4. Remove the oil fill plug/dipstick and wipe off oil. Reinsert it all the way back in.

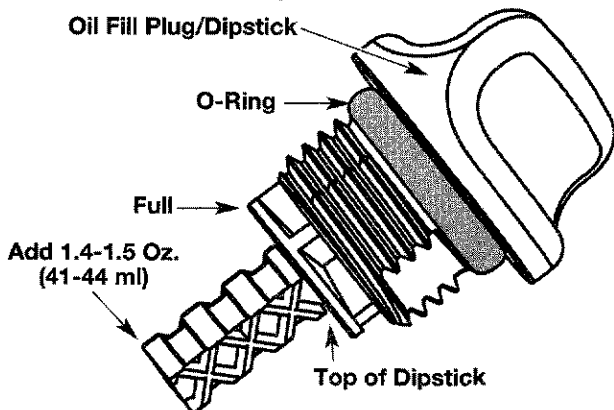

Fig. 40

5. Remove the oil fill plug/dipstick and check oil level. Oil should be up to the top of the dipstick (Fig. 40).
6. If the level is low, add a small amount of oil to the oil fill hole and recheck (Fig. 41). Repeat until the oil level reaches the top of the dipstick.

NOTE: Do not overfill the unit.

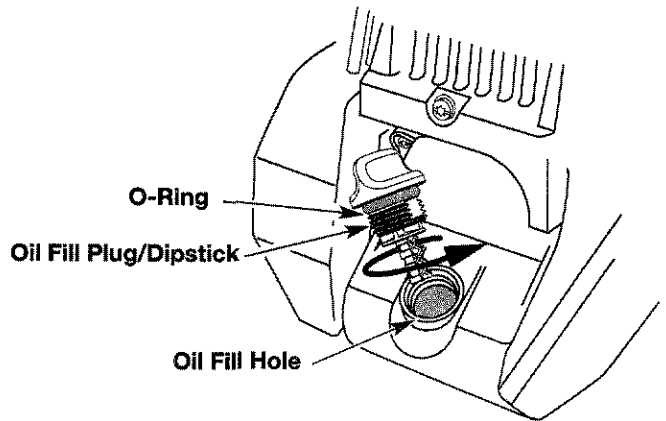

Fig. 41

NOTE: Make sure the O-ring is in place on the oil fill plug/dipstick when checking and changing the oil (Fig. 42).

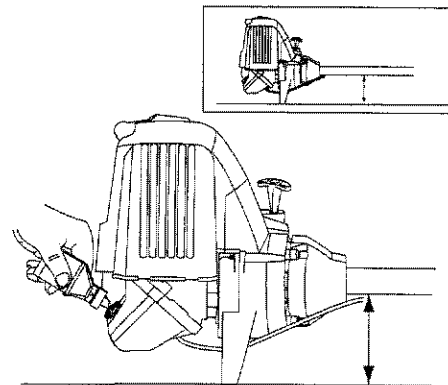
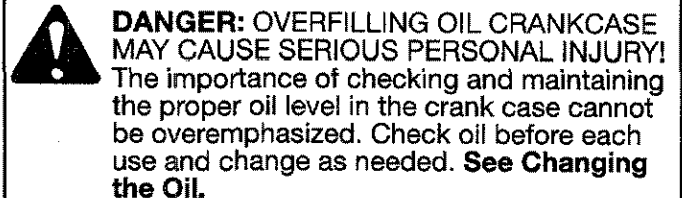

Fig. 42

MAINTENANCE AND REPAIR INSTRUCTIONS

CHANGING THE OIL

For a new engine, change the oil after the first 10 hours of operation. Change the oil while the engine is still warm. The oil will flow freely and carry away more impurities.



CAUTION: Wear gloves to prevent injury when handling the unit.

1. Unplug spark plug boot to eliminate starting
2. Remove the oil fill plug/dipstick.
3. Pour the oil out of the oil fill hole and into a container by tipping the unit to a vertical position (Fig. 43). Allow ample time for complete drainage.

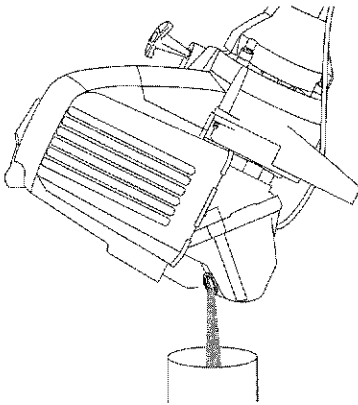

Fig. 43

4. Wipe up any oil residue on the unit and clean up any oil that may have spilled. Dispose of the oil according to Federal, State and local regulations.
5. Refill the crankcase with 3.4 fluid ounce (100 ml) of SAE 30 SF, SG, SH oil.

NOTE: Use the bottle and spout saved from initial use to measure the correct amount. 3.4 ounce (100 ml) is approximately to the top of the label on the bottle (Fig. 44) Check the level with the dipstick. If the level is low, add a small amount of oil and recheck (Fig. 40). Do not overfill.

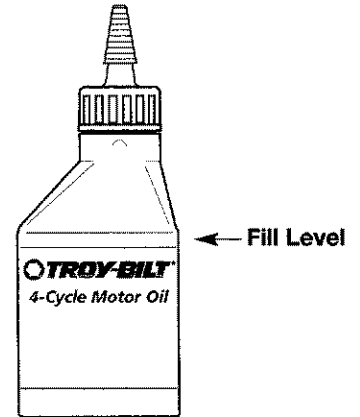

Fig. 44

6. Replace the oil fill plug/dipstick.
7. Reconnect spark plug boot.

MAINTENANCE AND REPAIR INSTRUCTIONS

AIR FILTER MAINTENANCE

Cleaning the Air Filter



WARNING: To avoid serious personal injury, always turn your trimmer off and allow it to cool before you clean or do any maintenance on it.

Clean and re-oil the air filter every 10 hours of operation. It is an important item to maintain. Not maintaining the air filter will **VOID** the warranty.

1. Open the air filter cover. Push the tab on the right side of the cover in, pull the air filter cover out and to the left (Fig. 45).

NOTE: It may be necessary to remove the fuel cap to completely remove the air filter cover

2. Remove the air filter (Fig. 45).

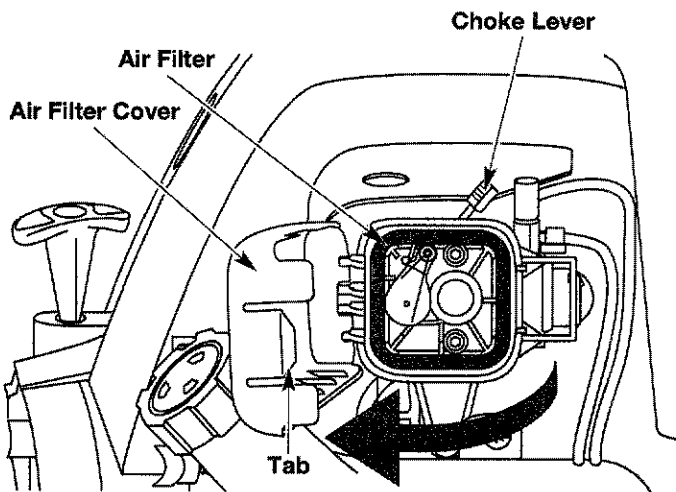

Fig. 45

3. Wash the filter in detergent and water (Fig. 46). Rinse the filter thoroughly and allow it to dry.

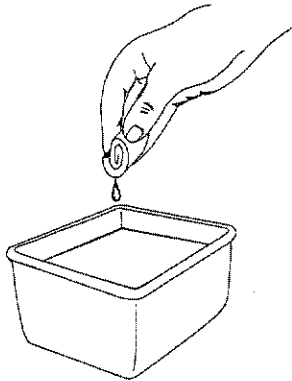

Fig. 46

4. Apply enough clean SAE 30 motor oil to lightly coat the filter (Fig. 47).

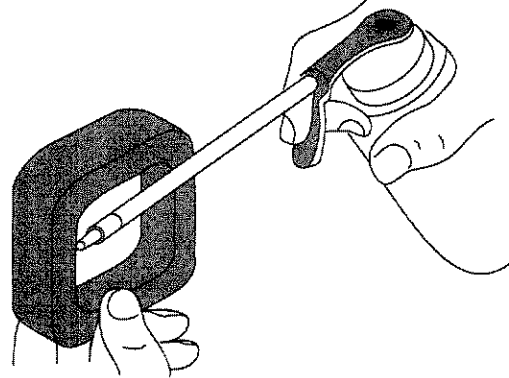

Fig. 47

5. Squeeze the filter to spread and remove excess oil (Fig. 48).

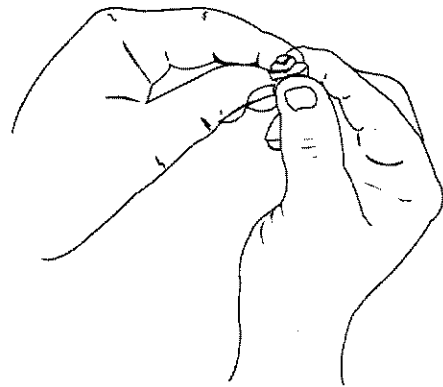

Fig. 48

6. Replace the filter (Fig. 49).

NOTE: If the unit is operated without the air filter, you will **VOID** the warranty.

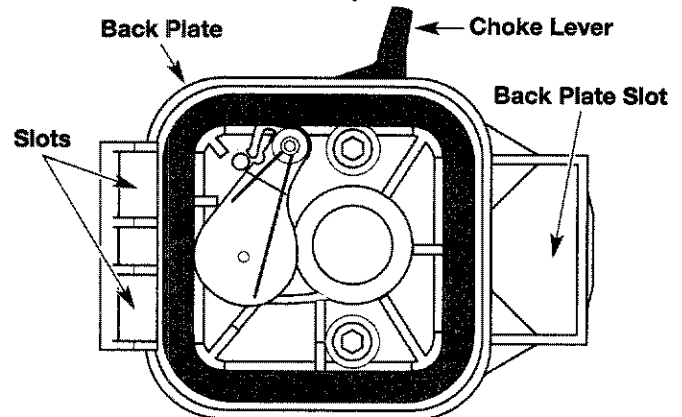

Fig. 49

7. Reinstall the air filter cover. Position the hooks on the left side of the air filter cover into the slots at the left side of the back plate (Fig. 49).

NOTE: It may be necessary to remove the fuel cap to reinstall the air filter cover

8. Swing the cover to the right until the tab on the air filter cover snaps into place in the slot on the back plate (Fig. 49).
9. Replace the fuel cap, if removed.

MAINTENANCE AND REPAIR INSTRUCTIONS

CARBURETOR ADJUSTMENT

The idle speed of the engine is adjustable. An idle adjustment screw is reached through a hole in the top of the engine cover (Fig 50).

NOTE: Careless adjustments can seriously damage your unit. An authorized service dealer should make carburetor adjustments.

Check Fuel

Old fuel is usually the main reason for the unit not running properly. Drain and refill the tank with clean, fresh unleaded fuel prior to doing any adjustments. Refer to **Oil and Fuel Information**.

Clean Air Filter

The condition of the air filter is important to the operation of the unit. A dirty air filter will restrict air flow and change the air/fuel mixture. This is often mistaken for an out of adjustment carburetor. Check the condition of the air filter before adjusting the idle speed screw. Refer to **Air Filter Maintenance**.

Adjust Idle Speed Screw



WARNING: The cutting attachment may be spinning during idle speed adjustment. Wear protective clothing and observe all safety instructions to prevent serious personal injury.

If after checking the fuel and cleaning the air filter the engine still will not idle, adjust the idle speed screw as follows.

1. Start the engine and let it run at a high idle for a minute to warm up.
2. Release the throttle trigger and let the engine idle. If the engine stops, insert a small phillips or flat blade screwdriver into the hole in the engine cover (Fig. 50). Turn the idle speed screw in, clockwise, 1/8 of a turn at a time (as needed) until the engine idles smoothly.

NOTE: The cutting attachment should not rotate when the engine idles.

3. If the cutting attachment rotates when the engine idles, turn the idle speed screw counterclockwise 1/8 of a turn at a time (as needed), to reduce idle speed.

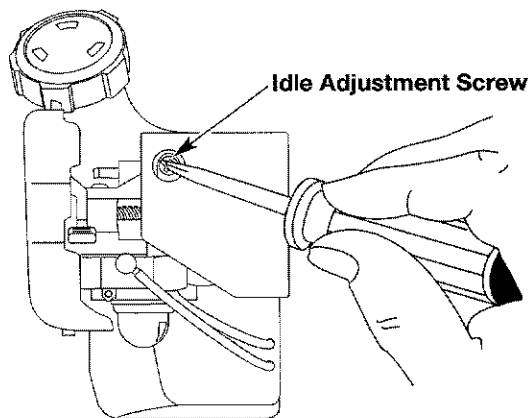

Fig. 50

Checking the fuel, cleaning the air filter, and adjusting the idle speed screw should solve most engine problems.

If not and:

- The engine will not idle,
- The engine hesitates or stalls on acceleration,
- There is a loss of engine power,

have the carburetor adjusted by an authorized service dealer.



WARNING: When the unit is turned off make sure the cutting attachment has stopped before the unit is set down to prevent serious personal injury.

ROCKER ARM CLEARANCE

This requires disassembly of the engine. If you feel unsure or unqualified to perform this, take the unit to an authorized service center.

NOTE: Inspect the valve to rocker arm clearance with a feeler gauge after the first 10 hours of operation and then every 25 hours of operation thereafter.

- The engine must be cold when checking or adjusting the valve clearance.
 - This task should be performed inside, in a clean, dust free area.
1. Remove the muffler cover by pressing down on the corner with a flat blade screwdriver (Fig. 51). Slide the notches on the sides of the muffler cover over the tabs on the engine cover and remove

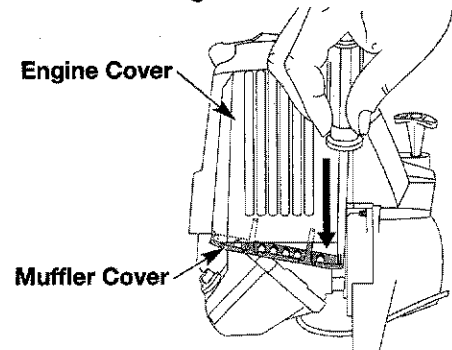

Fig. 51

2. Remove the two (2) screws on top of the engine cover with a flathead or T-20 Torx screwdriver (Fig. 52).

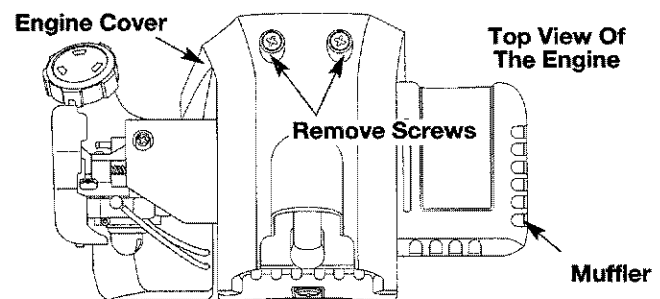

Fig. 52

MAINTENANCE AND REPAIR INSTRUCTIONS

- Remove the screw on back of the engine cover (Fig. 53).

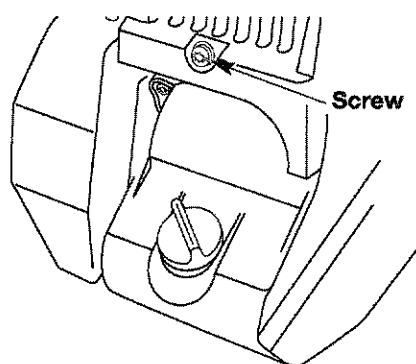

Fig. 53

- Clean dirt from around the spark plug. Remove the spark plug from the cylinder head by turning a 5/8 in. socket counterclockwise.
- Disconnect the spark plug wire.
- Remove the engine cover.
- Clean dirt from around the rocker arm cover. Remove the screw holding the rocker arm cover with a large flat blade screwdriver or Torx T25 bit (Fig. 54). Remove the rocker arm cover and gasket.

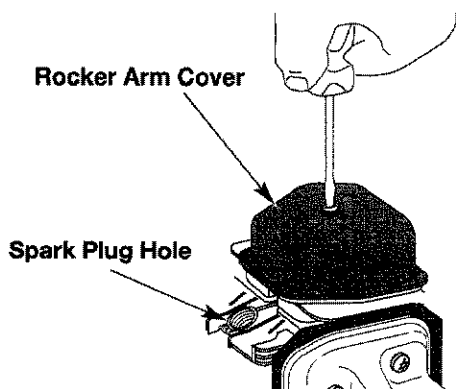

Fig. 54

- Pull the starter rope slowly to bring the piston to the top of its travel, (known as top dead center). Check that:
 - The piston is at the top of its travel while looking in the spark plug hole (Fig. 54).
 - Both rocker arms move freely, and both valves are closed.

If not, repeat this step.

- Slide the feeler gauge between the rocker arm and the valve return spring. Measure the clearance between the valve stem and rocker arm (Fig 55). Do both intake and exhaust valves.

The recommended clearance for both intake and exhaust is .003 - .006 in. (.076 - 0.152 mm). Use a standard automotive .005 in. (0.127 mm) feeler gauge. The feeler gauge should slide between the rocker arm and valve stem with a slight amount of resistance, without binding (Fig. 56).

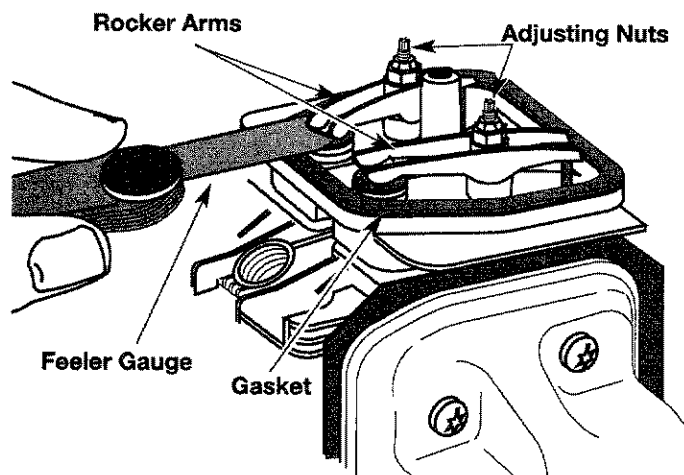

Fig. 55

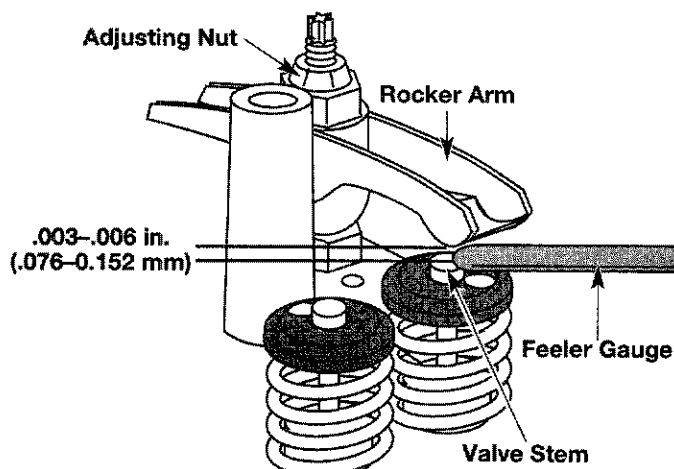

Fig. 56

- If the clearance is not within specification:
 - Turn the adjusting nut using a 5/16 inch (8 mm) wrench or nut driver (Fig. 55).
 - To increase clearance, turn the adjusting nut counterclockwise.
 - To decrease clearance, turn the adjusting nut clockwise.
 - Recheck both clearances, and adjust as necessary.
- Reinstall the rocker arm cover using a new gasket. Torque the screw to 20-30 in•lb (2.2-3.4 N•m).

NOTE: A rocker arm cover gasket, Part # 182099 can be purchased from your local authorized dealer.

- Reinstall the engine cover. Check alignment of the cover before tightening the screws. Tighten screws.
- Replace the muffler cover. Slip the long tabs on the muffler cover into the engine cover. Slide the notches on the side of the muffler cover over the tabs on the engine cover and snap into place (Fig. 51).
- Check the spark plug and reinstall. See **Replacing the Spark Plug**.
- Replace the spark plug wire.

MAINTENANCE AND REPAIR INSTRUCTIONS

REPLACING THE SPARK PLUG

Use only Champion RDZ19H spark plug or equivalent. The correct air gap is 0.025 in. (0.655 mm). Remove the plug after every 25 hours of operation and check its condition.

1. Stop the engine and allow it to cool. Grasp the plug wire firmly and pull the cap from the spark plug.
2. Clean dirt from around the spark plug. Remove the spark plug from the cylinder head by turning counterclockwise using a 5/8 inch deep socket.
3. Replace cracked, fouled or dirty spark plug. Set the air gap at 0.025 in. (0.655 mm) using a feeler gauge (Fig. 57).

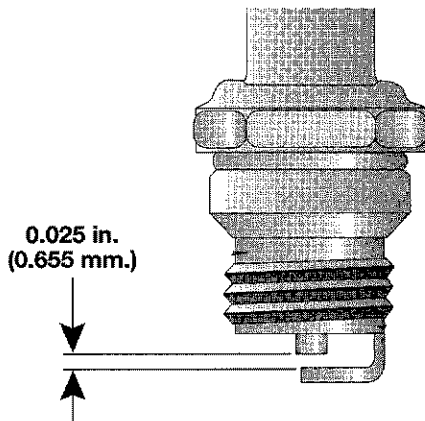

Fig. 57



CAUTION: Do not sand blast, scrape, or clean electrodes. Grit in the engine could damage the cylinder.

4. Install a correctly gaped spark plug in the cylinder head. Tighten by turning the 5/8 inch deep socket clockwise until snug.

If using a torque wrench torque to;
110-120 in.·lb. (12.3-13.5 N·m).
Do not over tighten.

SPARK ARRESTOR MAINTENANCE

1. Remove the muffler cover. See **Rocker Arm Clearance**, Pg. 22.
2. With a flat blade screwdriver or Torx T20 bit, remove the screw attaching the spark arrestor cover to the muffler (Fig. 58).

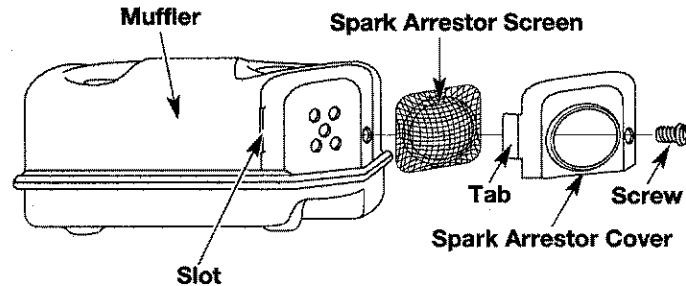

Fig. 58

3. Pull the tab on the spark arrestor cover out of the muffler. Remove the spark arrestor cover.
4. Remove the spark arrestor screen from the spark arrestor cover.
5. Clean the spark arrestor screen with a wire brush, or replace.
6. Reinstall the spark arrestor screen, spark arrestor cover, and screw.

ACCESSORIES/REPLACEMENT PARTS

4-Cycle Oil	753-1249
Oil Fill Plug / Dipstick	791-182378
Spark Plug	791-180852B
Spark Arrestor Screen	791-180890
Replacement Line	0.105in (2.667mm)
Replacement Line Cartridge	753-1160
Inner Reel Spring	791-610636B
Outer Spool	791-683301
Inner Reel	791-147495
Bump Knob™	791-180814B
Fuel Cap	791-181083
Shoulder Harness	791-682075B

These replacement parts can be purchased from your local authorized dealer or by calling 1-330-558-7220 or 1-866-840-6483.

CLEANING AND STORAGE

CLEANING



WARNING: To avoid serious personal injury, always turn your trimmer off and allow it to cool before you clean or do any maintenance on it.

Use a small brush to clean off the outside of the unit. Do not use strong detergents. Household cleaners that contain aromatic oils such as pine and lemon, and such as kerosene, can damage plastic housing or handle. Wipe off any moisture with a soft cloth.

STORAGE

- Never store the unit with gasoline in the tank where fumes may reach an open flame or spark.
- Allow the engine to cool before storing.
- Store the unit locked up to prevent unauthorized use or damage.
- Store the unit in a dry, well ventilated area.
- Store the unit out of the reach of children.

Store the unit in one of three (3) positions:

1. The unit hanging by the cutting attachment end.
2. The unit hanging by the engine.
3. The unit setting upright on the cutting attachment shield and engine feet.

LONG TERM STORAGE

If the unit will be stored for an extended time,

1. Drain all gasoline from the gas tank into a container. Do not use gas that has been stored for more than 60 days. Dispose of the old gasoline in accordance with Federal, State, and Local regulations.
2. Start the engine and allow it to run until it stalls. This ensures that all gasoline has been drained from the carburetor.
3. Allow the engine to cool. Remove the spark plug and put 1 oz. (30 ml) of high quality motor oil into the cylinder. Pull the starter rope slowly to distribute the oil. Reinstall the spark plug.

NOTE: Remove the spark plug and drain all of the oil from the cylinder before attempting to start the trimmer after storage.

4. Change the oil. See **Changing the Oil**. Dispose of the old oil in accordance with Federal, State, and Local regulations.
5. Thoroughly clean the unit and inspect for any loose or damaged parts. Repair or replace damaged parts and tighten loose screws, nuts or bolts. The unit is ready for storage.

TRANSPORTING

- Allow the engine to cool before transporting.
- Secure the unit while transporting.
- Drain the gas tank before transporting.
- Tighten gas cap before transporting.

TROUBLESHOOTING

ENGINE WILL NOT START

CAUSE

Ignition switch is OFF
Empty fuel tank
Primer bulb wasn't pressed enough
Engine flooded

Old Gasoline
Fouled spark plug

ACTION

Turn switch to ON
Fill fuel tank
Press primer bulb fully and slowly 5-7 times
Use starting procedure with choke lever in the RUN position, Pg. 13
Drain fuel tank / Add fresh Gasoline
Replace or clean the spark plug

ENGINE WILL NOT IDLE

CAUSE

Air Filter is Plugged
Old Gasoline
Improper carburetor adjustment

ACTION

Replace or clean the air filter
Drain fuel tank / Add fresh Gasoline
Adjust per instruction Pg. 22

ENGINE WILL NOT ACCELERATE

CAUSE

Old Gasoline
Improper carburetor adjustment

Cutting head bound with grass
Dirty air filter
Clogged Spark Arrestor Screen

ACTION

Drain gas tank / Add fresh Gasoline
Take to an authorized service dealer for carburetor adjustment
Stop the engine and clean the cutting attachment
Clean or replace the air filter
Clean or Replace. See Pg. 24

ENGINE LACKS POWER OR STALLS WHEN CUTTING

CAUSE

Old Gasoline
Improper carburetor adjustment

Clogged Spark Arrestor Screen

ACTION

Drain fuel tank / Add fresh Gasoline
Take to an authorized service dealer for carburetor adjustment
Clean or Replace. See Pg. 24

CUTTING HEAD WILL NOT ADVANCE LINE

CAUSE

Cutting head bound with grass
Cutting head out of line
Inner reel bound up
Cutting head dirty
Line welded

Line twisted when refilled
Not enough line is exposed

ACTION

Stop the engine and clean cutting attachment
Refill with new line
Replace the inner reel
Clean inner reel and outer spool
Disassemble, remove the welded section and rewind the line
Disassemble and rewind the line
Push the Bump Knob and pull out line until 4 inches (102 mm) of line is outside of the cutting attachment

If further assistance is required, contact your authorized service dealer.

SPECIFICATIONS

ENGINE

Engine Type	Air-Cooled, 4-Cycle
Displacement	1.6 cu. in. (26.2 cc)
Clutch Type	Centrifugal
Operating RPM (Trimmer)	7,200-8,300 rpm
Operating RPM (Brushcutter)	7,200-9,800 rpm
Idle Speed RPM	3,000-3,600 rpm
Ignition Type	Electronic
Ignition Switch	Rocker Switch
Valve clearance (intake and exhaust)	.003-.006 in. (.076-.0152 mm)
Spark Plug Gap	0.025 inch (0.655 mm)
Lubrication	SAE 30 Oil
Crankcase Oil Capacity	3.4 oz (100 ml)
Fuel	Unleaded
Carburetor	Diaphragm, All-Position
Starter	Auto Rewind
Muffler	Baffled with Guard
Throttle	Manual Spring Return
Fuel Tank Capacity	20 oz (591 ml)
Fuel Tank	HD Polyethylene

DRIVE SHAFT & CUTTING ATTACHMENT

Drive Shaft Housing	Aluminum Tube (EZ-Link™)
Throttle Control	Finger-Tip Trigger
Unit Weight (No Fuel, with J-handle, Cutting attachment shield and Cutting attachment)	13.5 lbs (6.13 kg)
Cutting Mechanism	4-Tooth Cutting Blade, Dual String Cutting Head
Line Spool	Bump Line Releaser
Line Spool Diameter	4 inches (101.6 mm)
Trimming Line Diameter	0.105 inch (2.66 mm)
Cutting Path Diameter, Cutting Attachment	18 inches (45.7 cm)
Cutting Path Diameter, Cutting Blade	8 Inches (204 mm)
Shoulder Harness	Single Quick-Snap

ENGINE PARTS - MODEL TB490BC

4-CYCLE GAS TRIMMER

(ppn - 41ADT49C063) (Serial Number 011..... and greater)

Part Numbers On Following Page

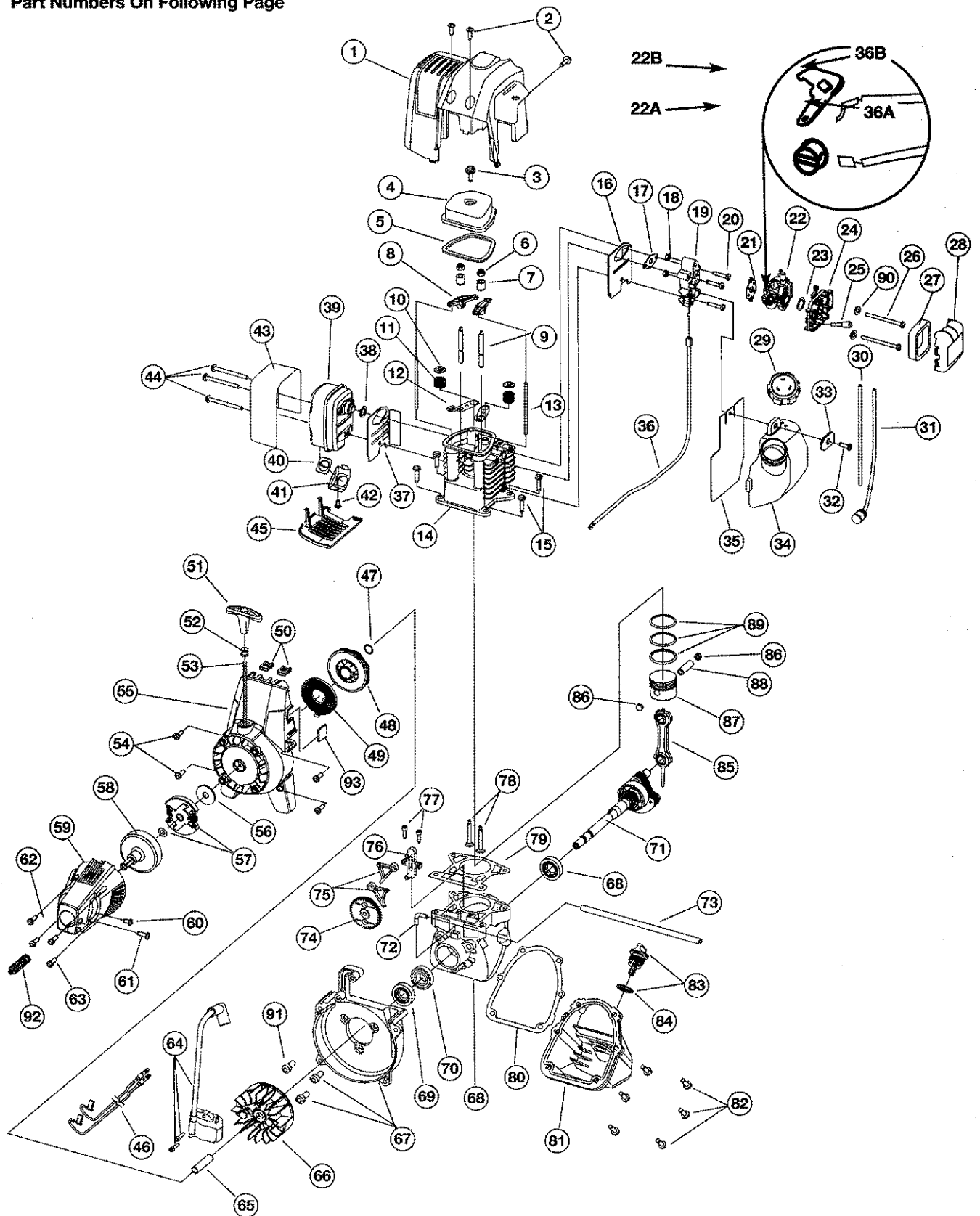

ENGINE PARTS - MODEL TB490BC
4-CYCLE GAS TRIMMER
(ppn - 41ADT49C063) (Serial Number 011..... and greater)

<u>Item</u>	<u>Part No.</u>	<u>Description</u>	<u>Item</u>	<u>Part No.</u>	<u>Description</u>
1	791-182338	Engine Cover	47	791-181247	Painut
2	791-182339	Engine Cover Screws	48	753-1199	Recoil Pulley
3	791-181025	Valve Cover Screw	49	791-613102	Recoil Spring
4	791-182098	Valve Cover	50	791-182366	Nut Clip
5	791-182099	Valve Cover Gasket	51	791-181079	Pull Handle
6	791-182340	Rocker Adjustment Nut	52	791-611061	Rope Guide
7	791-182101	Rocker Arm Pivot	53	791-613103	Rope
8	791-182100	Rocker Arm	54	791-181020	Starter Housing Screw
9	791-182341	Rocker Arm Stud	55	753-1237	Starter Housing Assembly (includes 49-56)
10	791-182103	Valve Spring Retainer	56	791-182368	Clutch Washer
11	791-181038	Valve Spring	57	753-1238	Clutch with Spacer
12	791-182102	Push Rod Guide	58	791-153592	Clutch Drum
13	791-181033	Push Rod	59	753-1239	Clutch Cover
14	791-182700	Cylinder Head (includes 9 & 12)	60	791-145569	Anti-Rotation Screw
15	791-182344	Cylinder Screw	61	753-1240	Screw
16	791-182345	Intake Baffle	62	753-1241	Nut
17	791-182749	Carburetor Mount Gasket	63	791-181345	Clutch Cover Screw
18	791-181034	Nut	64	791-182725	Ignition Module with Screws
19	791-182347	Carburetor Mount (includes 18)	65	791-181065	Spacer
20	791-182348	Carburetor Mount Screw	66	791-181867	Flywheel
21	791-182732	Carburetor Gasket	67	791-182743	Shroud Assembly with Screws
22A	791-182654	Carburetor with Primer	68	753-1244	Crankcase Assembly (includes 69-73)
22B	753-1225	Carburetor with Primer	69	791-610309	Oil Seal
23	791-181751	O-Ring, Carburetor	70	791-182372	Bearing
24	753-1227	Air Filter/Choke Cover Assembly (includes 27 & 28)	71	791-182380	Crankshaft
25	791-182097	Breather Tube	72	791-182375	90° Elbow
26	791-181750	Air Filter Mounting Screw	73	791-182379	Breather Hose
27	791-181757	Air Filter	74	791-181015	Cam Gear
28	753-1228	Air Filter Cover	75	753-1242	Cam Follower Set
29	753-1229	Fuel Cap	76	791-181013	Cam Bracket
30	791-182352	Fuel Return Line	77	791-181012	Cam Bracket Screw
31	791-182353	Fuel Pick-Up Line with Filter	78	791-181040	Valves, Intake and Exhaust
32	791-181080	Screw	79	791-182374	Cylinder Gasket
33	791-182354	Washer	80	791-181018	Oil Pan Gasket
34	753-1230	Fuel Tank Assembly (includes 29-31)	81	791-182377	Oil Pan (includes 80 & 82)
35	791-182356	Fuel Tank Shield	82	791-181020	Oil Pan Screw
36A	753-1234	Throttle Cable	83	791-182378	Dipstick Assembly (includes 84)
36B	753-1231	Throttle Cable	84	791-182290	O-Ring
37	791-182358	Muffler Baffle	85	791-181009	Connecting Rod
38	791-181048	Muffler Gasket	86	791-181008	Wrist Pin Button
39	791-182359	Muffler (includes 40, 42-44)	87	753-1243	Piston
40	791-180890	Spark Arrestor Screen	88	791-181006	Wrist Pin
41	791-181045	Screen Cover	89	791-182295	Piston Ring Set
42	791-181046	Screw	90	791-182409	Washer
43	791-182360	Muffler Shield	91	791-181861	Screw
44	791-182361	Muffler Mounting Screw	92	791-612468	Compression Spring
45	791-182362	Muffler Cover	93	791-182537	Grommet
46	791-182804	Switch Wire Assembly	*	791-180852B	Spark Plug
			*	753-1245	Short Block Assembly (includes 3-7, 68-89)
			*	791-182745	Cylinder Assembly (includes 9, 12, 14 & 79)
			*	791-180142	Starter Pawl Repair Kit
			*	791-182156	Carburetor Repair Kit
			*	753-1248	Gasket Diaphragm Repair Kit
			*		Parts not shown

BOOM AND TRIMMER PARTS - MODEL TB490BC

4-CYCLE GAS TRIMMER

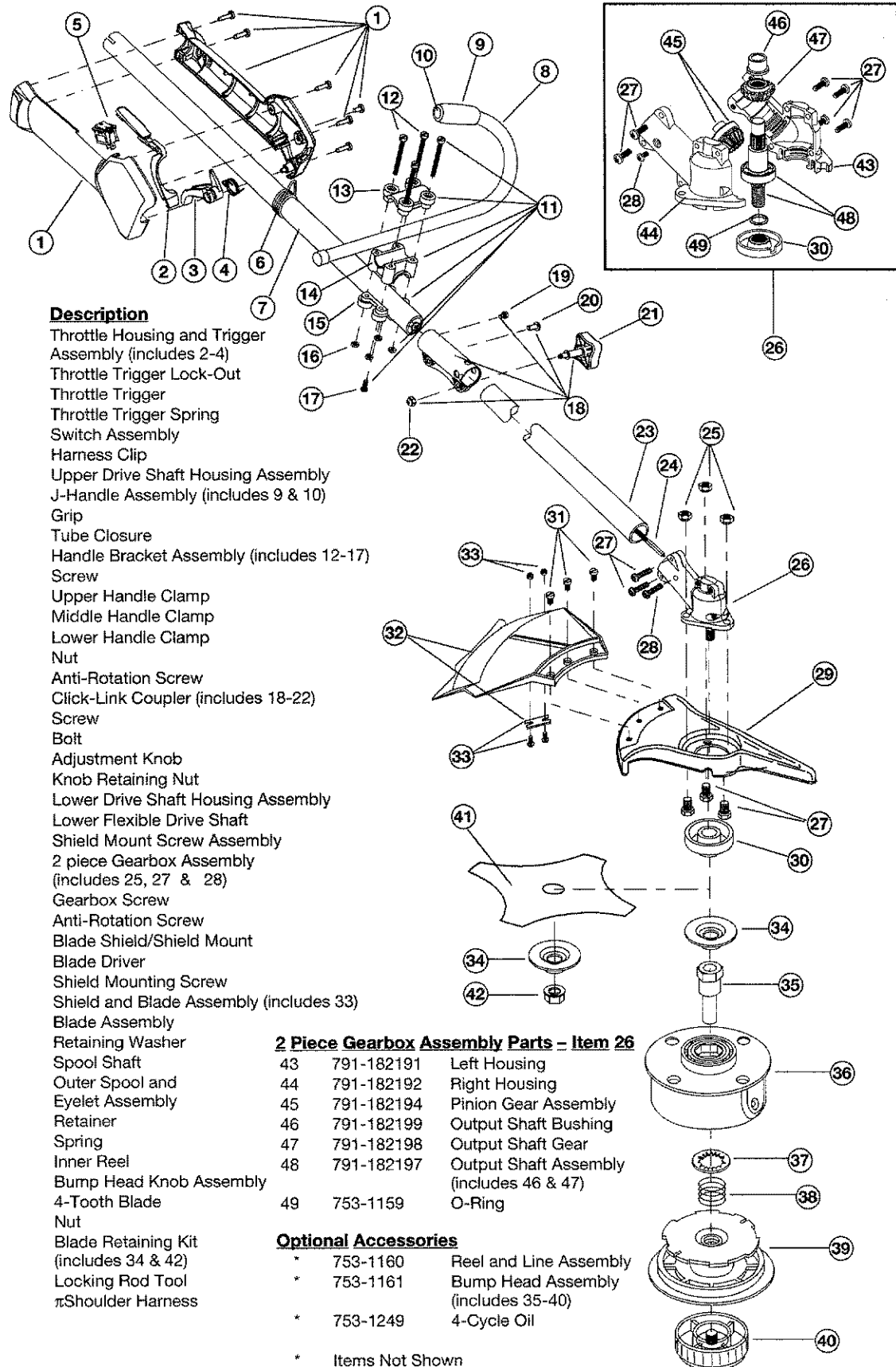

Item	Part No.	Description
1	791-00040	Throttle Housing and Trigger Assembly (includes 2-4)
2	791-00041	Throttle Trigger Lock-Out
3	791-00042	Throttle Trigger
4	791-182690	Throttle Trigger Spring
5	791-182673	Switch Assembly
6	791-610327	Harness Clip
7	753-1247	Upper Drive Shaft Housing Assembly
8	791-181099	J-Handle Assembly (includes 9 & 10)
9	791-612831	Grip
10	791-612021	Tube Closure
11	791-683295	Handle Bracket Assembly (includes 12-17)
12	791-181811	Screw
13	791-181812	Upper Handle Clamp
14	791-181813	Middle Handle Clamp
15	791-181814	Lower Handle Clamp
16	791-181815	Nut
17	791-145569	Anti-Rotation Screw
18	753-1190	Click-Link Coupler (includes 18-22)
19	791-182057	Screw
20	791-181617	Bolt
21	791-181981	Adjustment Knob
22	791-181886	Knob Retaining Nut
23	791-182541	Lower Drive Shaft Housing Assembly
24	791-613300	Lower Flexible Drive Shaft
25	791-182200	Shield Mount Screw Assembly
26	791-182193	2 piece Gearbox Assembly (includes 25, 27 & 28)
27	791-182195	Gearbox Screw
28	791-145569	Anti-Rotation Screw
29	791-147492	Blade Shield/Shield Mount
30	791-182196	Blade Driver
31	791-683304	Shield Mounting Screw
32	753-1191	Shield and Blade Assembly (includes 33)
33	791-682061	Blade Assembly
34	791-147490	Retaining Washer
35	791-612483	Spool Shaft
36	791-683301	Outer Spool and Eyelet Assembly
37	791-612026	Retainer
38	791-610636B	Spring
39	791-147495	Inner Reel
40	791-180814B	Bump Head Knob Assembly
41	791-145873B	4-Tooth Blade
42	791-181699	Nut
*	791-180014B	Blade Retaining Kit (includes 34 & 42)
*	791-613226	Locking Rod Tool
*	791-682075B	Shoulder Harness

2 Piece Gearbox Assembly Parts - Item 26

43	791-182191	Left Housing
44	791-182192	Right Housing
45	791-182194	Pinion Gear Assembly
46	791-182199	Output Shaft Bushing
47	791-182198	Output Shaft Gear
48	791-182197	Output Shaft Assembly (includes 46 & 47)
49	753-1159	O-Ring

Optional Accessories

*	753-1160	Reel and Line Assembly
*	753-1161	Bump Head Assembly (includes 35-40)
*	753-1249	4-Cycle Oil
*	Items Not Shown	

NOTES

MANUFACTURER'S LIMITED WARRANTY FOR:



The limited warranty set forth below is given by Troy-Bilt LLC with respect to new merchandise purchased and used in the United States, its possessions and territories.

Troy-Bilt LLC warrants this product against defects in material and workmanship for a period of two (2) years commencing on the date of original purchase and will, at its option, repair or replace, free of charge, any part found to be defective in material or workmanship. This limited warranty shall only apply if this product has been operated and maintained in accordance with the Operator's Manual furnished with the product, and has not been subject to misuse, abuse, commercial use, neglect, accident, improper maintenance, alteration, vandalism, theft, fire, water or damage because of other peril or natural disaster. Damage resulting from the installation or use of any accessory or attachment not approved by Troy-Bilt LLC for use with the product(s) covered by this manual will void your warranty as to any resulting damage. This warranty is limited to ninety (90) days from the date of original retail purchase for any Troy-Bilt product that is used for rental or commercial purposes, or any other income-producing purpose.

HOW TO OBTAIN SERVICE: Warranty service is available, WITH PROOF OF PURCHASE THROUGH YOUR LOCAL AUTHORIZED SERVICE DEALER. To locate the dealer in your area, visit our website at www.troybilt.com, check for a listing in the Yellow Pages, call 1 (866) 840-6483 or 1 (330) 558-7220 or write to P.O. Box 361131, Cleveland, OH 44136-0019.

This limited warranty does not provide coverage in the following cases:

- A. Tune-ups - Spark Plugs, Carburetor Adjustments, Filters
- B. Wear items - Bump Knobs, Outer Spools, Cutting Line, Inner Reels, Starter Pulley, Starter Ropes, Drive Belts
- C. Troy-Bilt LLC does not extend any warranty for products sold or exported outside of the United States of America, its possessions and territories, except those sold through Troy-Bilt's authorized channels of export distribution.

Troy-Bilt LLC reserves the right to change or improve the design of any Troy-Bilt Product without assuming any obligation to modify any product previously manufactured.

No implied warranty, including any implied warranty of merchantability or fitness for a particular purpose, applies after the applicable period of express written warranty above as to the parts as identified. No other express warranty or guaranty, whether written or oral, except as mentioned above, given by any person or

entity, including a dealer or retailer, with respect to any product shall bind Troy-Bilt LLC During the period of the Warranty, the exclusive remedy is repair or replacement of the product as set forth above. (Some states do not allow limitations on how long an implied warranty lasts, so the above limitation may not apply to you.)

The provisions as set forth in this Warranty provide the sole and exclusive remedy arising from the sales. Troy-Bilt LLC shall not be liable for incidental or consequential loss or damages including, without limitation, expenses incurred for substitute or replacement lawn care services, for transportation or for related expenses, or for rental expenses to temporarily replace a warranted product. (Some states do not allow limitations on how long an implied warranty lasts, so the above limitation may not apply to you.)

In no event shall recovery of any kind be greater than the amount of the purchase price of the product sold. Alteration of the safety features of the product shall void this Warranty. You assume the risk and liability for loss, damage, or injury to you and your property and/or to others and their property arising out of the use or misuse or inability to use the product.

This limited warranty shall not extend to anyone other than the original purchaser, original lessee or the person for whom it was purchased as a gift.

How State Law Relates to this Warranty: This warranty gives you specific legal rights, and you may also have other rights which vary from state to state.

To locate your nearest service dealer dial 1 (877) 282-8684

Troy-Bilt LLC
P.O. Box 361131
Cleveland, OH 44136-0019