

Operator's manual (CARB II)

326P4 326P4

X-SERIES

326P5

X-SERIES

Please read these instructions carefully and make sure you understand them before using the machine.

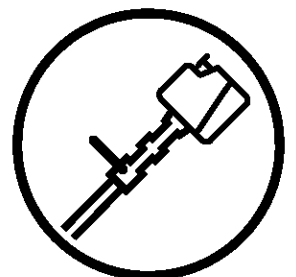

English

SYMBOL EXPLANATION

Symbols



WARNING! This machine can be dangerous. Careless or incorrect use can result in serious or fatal injury to the operator or others.



Read through the Operator's Manual carefully and understand the content before using the machine.



Always use

- A protective helmet where there is a risk of falling objects
- Ear protection
- Approved eye protection



- This product is in accordance with applicable CE directives.

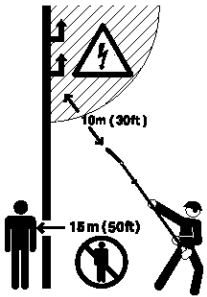

- This machine is not electrically insulated. If the machine touches or comes close to high-voltage power lines it could lead to death or serious injury. Electricity can jump from one point to another by arcing. The higher the voltage, the greater the distance electricity can jump. Electricity can also travel through branches and other objects, especially if they are wet. Always keep a safe distance of at least 10 m (30 ft) between the machine and high-voltage power lines and/or any objects that are touching them. If you need to work closer than this always contact the relevant power company to make sure the power is switched off before you start work.
- This machine has a long reach. Make sure that no people or animals come closer than 15 m (45 ft) when the machine is running.



- Always wear approved protective gloves.



- Use anti-slip and stable boots.

Other symbols/decals on the machine refer to special certification requirements for certain markets.

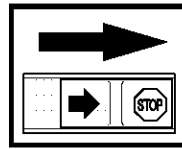

- Checks and/or maintenance should be carried out with the engine switched off, with the stop switch in the STOP position.

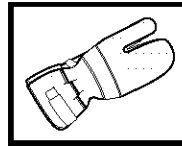

- Always wear approved protective gloves.

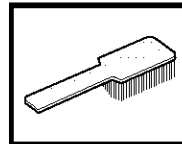

- Regular cleaning required.

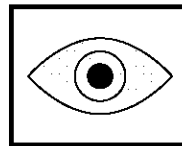

- Ocular control.

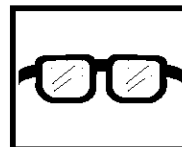

- Approved eye protection must always be used.

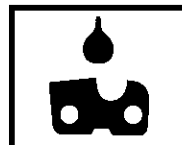

- Chain oil and chain oil flow adjustment

CONTENTS

Husqvarna AB has a policy of continuous product development and therefore reserves the right to modify the design and appearance of products without prior notice.

Maintenance, replacement, or repair of the emission control devices and systems may be performed by any nonroad engine repair establishment or individual.



WARNING!
Under no circumstances may the design of the machine be modified without the permission of the manufacturer. Always use genuine accessories. Non-authorized modifications and/or accessories can result in serious personal injury or the death of the operator or others.

Your warranty does not cover damage or liability caused by the use of non-authorized accessories or replacement parts.



WARNING!
The inside of the muffler with catalytic converter contains chemicals that may cause cancer. Do not contact inside of damaged muffler.

IMPORTANT ENGINE INFORMATION



HUSQVARNA AB HUSKVARNA SWEDEN TWC
THIS ENGINE CONFORMS TO U.S. EPA PH2 AND 2000-2003 CALIFORNIA EMISSION REGULATIONS FOR SMALL OFF-ROAD ENGINES. REFER TO OPERATOR'S MANUAL FOR MAINTENANCE SPECIFICATIONS AND ADJUSTMENTS.
THE AIR INDEX OF THIS ENGINE IS 3

0	2	3	4	5	6	8	10
---	---	---	---	---	---	---	----

THE LOWER THE AIR INDEX, THE LESS POLLUTION
EMISSIONS COMPLIANCE PERIOD: CATEGORY C

This decal certifies that the product has been approved in accordance with American exhaust emissions requirements EPA Ph II and CARB Tier II.

The Emissions Compliance Period referred to on the Emissions Compliance label indicates the numbers of operating hours for which the engine has been shown to meet Federal and California emission requirements.
Category C = 50 hours, B = 125 hours, and A = 300 hours.



WARNING

The engine exhaust from this product contains chemicals known to the State of California to cause cancer, birth defects or other reproductive harm.

List of contents

SYMBOL EXPLANATION

Symbols 2

CONTENTS

List of contents 3

SAFETY INSTRUCTIONS

Personal protective equipment 4

The machine's safety equipment 4

Control, maintenance and service of the machine's safety equipment 6

Specification of blade and chain 7

Sharpening your chain and adjusting raker clearance 8

Tensioning the saw chain 10

Lubricating cutting equipment 10

Checking wear on cutting equipment 11

General safety instructions 12

Safety instructions when using the machine 13

Basic working techniques 14

WHAT IS WHAT?

What is what on the machine? 16

ASSEMBLY

Fitting the cutting head 17

Mounting guide bar and chain 17

Adjusting the harness 17

Filling with oil 17

Assembling and dismantling the two-part shaft (326P5) 18

FUEL HANDLING

Fuel mixture 19

Fuelling 19

START AND STOP

Control before starting 20

Start and stop 20

MAINTENANCE

Carburetor 21

Muffler 23

Cooling system 23

Spark plug 23

Air filter 24

Maintenance schedule 24

TECHNICAL DATA

326P4 25

326P4 25

326P5 25

FEDERAL AND CALIFORNIA EMISSION CONTROL

WARRANTY STATEMENT

Your warranty rights and obligations 27

SAFETY INSTRUCTIONS

Personal protective equipment

IMPORTANT INFORMATION

- If used incorrectly or carelessly this machine can become a dangerous tool that can cause serious or fatal injury to the operator or others. It is extremely important that you read and understand the content of this manual.
- When using the machine, personal protective equipment approved by the appropriate authorities must be used. Personal protective equipment does not eliminate the risk of accidents. However, it can reduce the effects of an injury in the event of an accident. Ask your dealer for help when choosing protective equipment.



WARNING!

Remove your hearing protection as soon as you stop the engine, so that you can hear any noises or warning signals.

GLOVES

Gloves must be worn whenever required, for example when fitting, inspecting or cleaning cutting equipment.

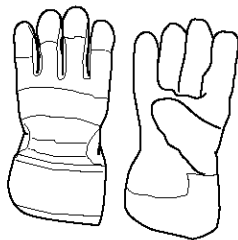

PROTECTIVE HELMET AND VISOR

EAR PROTECTION

Ear protection offering sufficient dampening effect should be used.



EYE PROTECTION

Blows from branches or objects thrown out by the cutting equipment can damage the eyes.

BOOTS

Use anti-slip and stable boots.



CLOTHING

Wear clothes made of a strong fabric and avoid loose clothing that can catch on shrubs and branches. Always wear heavy, long pants. Do not wear jewelry, short pants, sandals or go barefoot. Secure hair so it is above shoulder level.



FIRST AID KIT

The operator must carry a first aid kit.

The machine's safety equipment

This section describes the machine's safety equipment, its function and how checks and maintenance are carried out to ensure that it operates correctly. (See the chapter "What is what" to locate where this equipment is positioned on your machine.)



WARNING!

Never use a machine with defective safety equipment. Follow the control, maintenance and service instructions described in this section.

1. Throttle trigger lock

The throttle trigger lock is designed to prevent the throttle from accidentally being engaged. When the trigger lock (A) is pressed into the handle (= when you hold the handle) the throttle (B) is released. When the grip on the handle is released the throttle and the throttle trigger lock return to their original positions. This takes place via two independent return spring systems. This means that the throttle is automatically locked in its "idling" position.

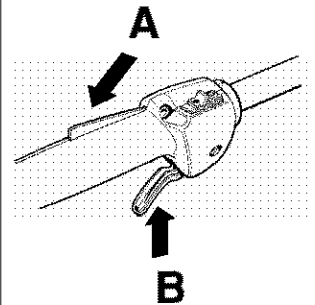

2. Stop switch

The stop switch should be used to stop the engine.

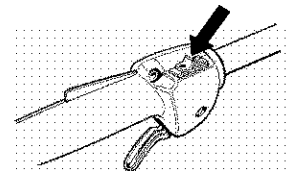

SAFETY INSTRUCTIONS

3. Vibration damping system

Your machine is equipped with a vibration damping system, which is designed to give as vibration-free and comfortable use as possible.

The machine's vibration damping system reduces the transfer of vibrations between the engine unit/cutting equipment and the machine's handle unit.

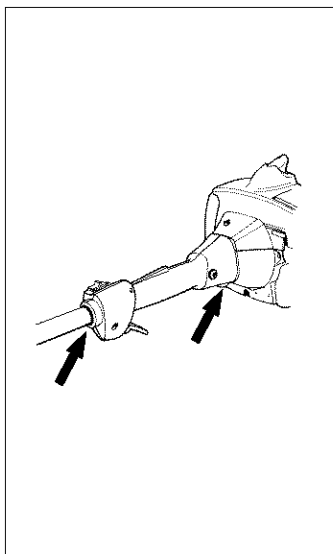

WARNING!

Over exposure to vibrations can result in blood-vessel or nerve injury to persons suffering with blood circulation problems. Seek medical attention if you experience physical symptoms that can be related to over exposure to vibrations. Examples of such symptoms are 'numbness', lack of feeling, 'tickling', 'pricking', 'pain', lack of or a reduction in normal strength, changes in the colour of the skin or its surfaces. These symptoms normally appear in the fingers, hands or wrists.

4. Muffler

The muffler is designed to give the lowest possible noise level and to direct the engine's exhaust fumes away from the operator. Muffler fitted with catalytic converter is also designed to reduce harmful exhaust components.

In countries that have a warm and dry climate the risk of fire is obvious. We have therefore fitted certain mufflers with a spark arrest screen. Make sure that your muffler is fitted with this kind of screen.

It is extremely important that the instructions for checking, maintaining and servicing the muffler are followed. (see the section "Control, maintenance and service of the machine's safety equipment").

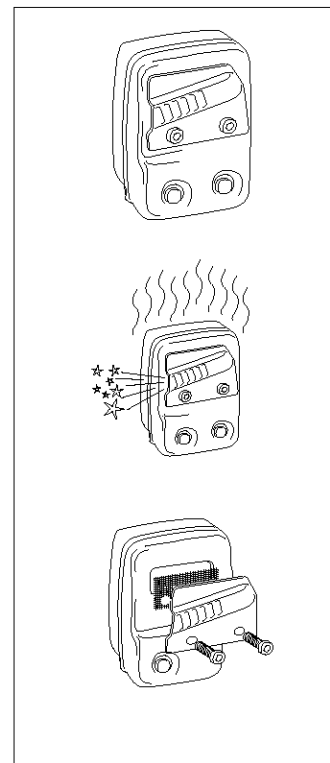

WARNING!

Mufflers fitted with catalytic converters become extremely hot during use and after stopping. This also applies at idling speeds. Contact can result in burns to the skin. Be observant to the risk of fire!



WARNING!

Bear in mind that exhaust fumes:

- contain carbon monoxide, which can cause carbon monoxide poisoning. Therefore never start or run the machine indoors.
- are hot and can contain sparks that can cause fires. Never start the machine indoors or close to inflammable material.

SAFETY INSTRUCTIONS

Inspecting, maintaining and servicing machine safety equipment

IMPORTANT INFORMATION

- All service and repairs to the machine require special training.
- This applies especially to the machine's safety equipment. If the machine does not meet any of the controls listed below you should contact your service workshop.
- The purchase of one of our products guarantees that professional repair and servicing will be carried out on it. If the point of purchase is not one of our servicing dealers, please ask for details of the closest service workshop.

1. Throttle trigger lock

- Check that the throttle is locked in the "idling position" when the throttle trigger lock is in its original position.
- Press in the throttle trigger lock and make sure it returns to its original position when released.
- Ensure that the throttle and throttle trigger lock move easily and that their return spring systems function.
- See section "Start". Start the machine and apply full throttle. Release the throttle and check that the cutting equipment stops and remains at a standstill. If the cutting equipment moves with the throttle in the idling position, then the carburettor's idling setting must be checked. See chapter "Maintenance".

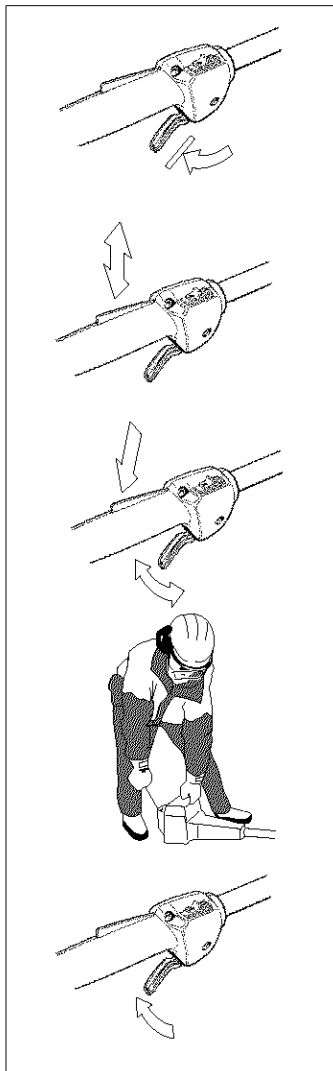

2. Stop switch

- Start the engine and make sure that the engine stops when the stop switch is moved to the stop position.

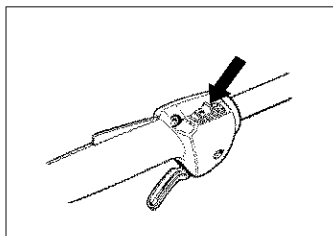

3. Vibration damping system

- Check the vibration damping element regularly for material cracks and distortion.
- Check that the vibration damping element is undamaged and securely attached.

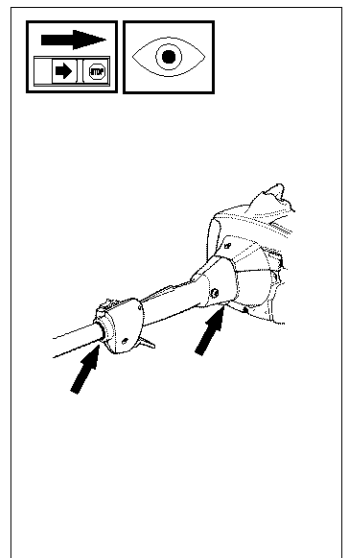

4. Muffler

1. Never use a machine that has a defective muffler.
2. Check regularly that the muffler is secure.
3. If your muffler is fitted with a spark arrest screen then it should be cleaned regularly. A blocked screen leads to the engine overheating with serious damage as a result. Never use a muffler with a defective spark arrest screen.

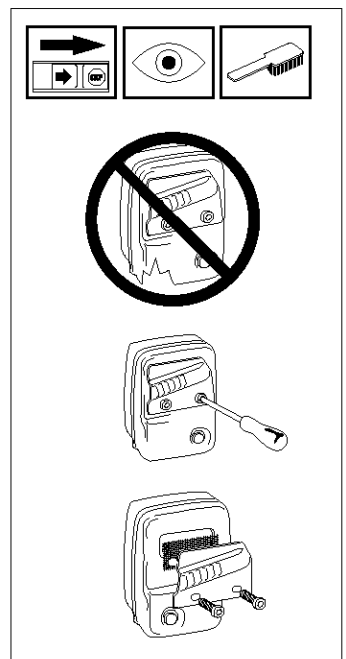

SAFETY INSTRUCTIONS

5. Cutting equipment

This section describes how through correct maintenance and through using the right type of cutting equipment you can:

- Obtain maximum cutting capacity.
- Increase the service life of the cutting equipment.

1 Check the cutting equipment with regard to damage and crack formation. Damaged cutting equipment should always be replaced.

2 Only use cutting equipment recommended by us! See the "Technical data" section.

3 Keep the chain cutting teeth properly sharpened! Follow our instructions and use the recommended file gauge. A damaged or badly sharpened chain increases the risk of accidents.

4 Maintain the correct raker clearance! Follow our instructions and use the recommended raker gauge. Too large a clearance increases the risk of kickback.

5 Keep the chain properly tensioned! If the chain is slack it is more likely to jump off and lead to increased wear on the bar, chain and drive sprocket.

6 Keep cutting equipment well lubricated and properly maintained! A poorly lubricated chain is more likely to break and lead to increased wear on the bar, chain and drive sprocket.

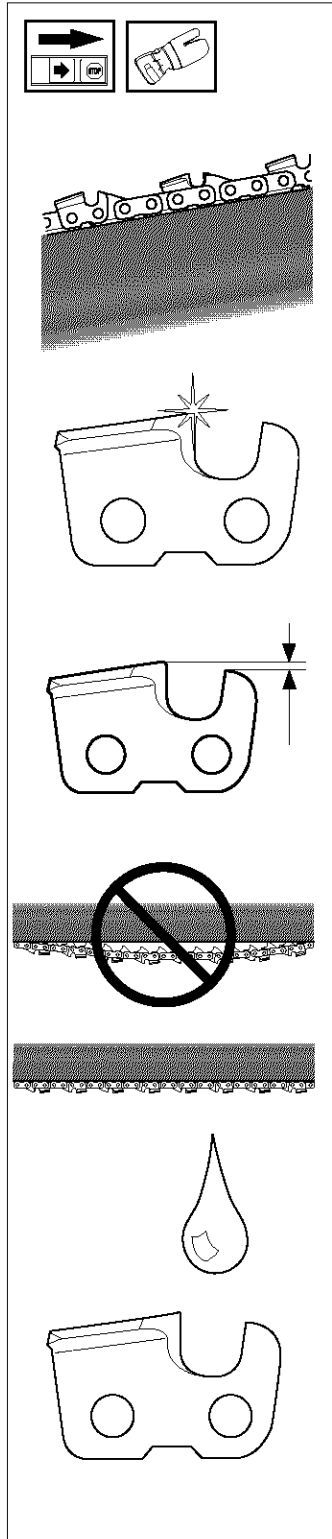

WARNING!
Never use a machine with defective safety equipment. The safety equipment should be maintained as described in this section. If your machine does not meet any of these controls you should contact your service workshop.

WARNING!
Always stop the engine before carrying out any work on the cutting equipment. This will continue to move even after the throttle has been released. Make sure the cutting equipment has stopped completely and disconnect the HT lead from the spark plug before you start work on it.

Specification of blade and chain

When the cutting equipment supplied with your machine becomes worn or damaged, you will need to replace it. Use only the manufacturer approved bar and chain.

Guide bar

- Length (inches/cm)
- Number of teeth on bar tip sprocket (T).
Small number = small tip radius = low-kickback
- Chain pitch (inches)
The spacing between the drive links of the chain must match the spacing of the teeth on the bar tip sprocket and drive sprocket.
- Number of drive links
The number of drive links is determined by the length of the bar, the chain pitch and the number of teeth on the bar tip sprocket.
- Bar groove width (inches/mm)
The groove in the bar must match the width of the chain drive links.
- Saw chain oil hole and hole for chain tensioner

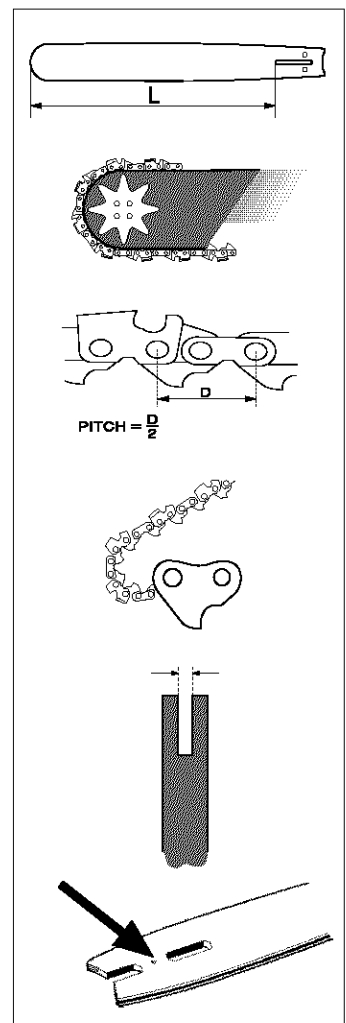

SAFETY INSTRUCTIONS

Saw chain

- Saw chain pitch (inches)
Spacing between drive links.
- Drive link width (mm/
inches).
- Number of drive links.
- Level of kickback reduction
The level of kickback reduction offered by a chain is indicated by its model number.

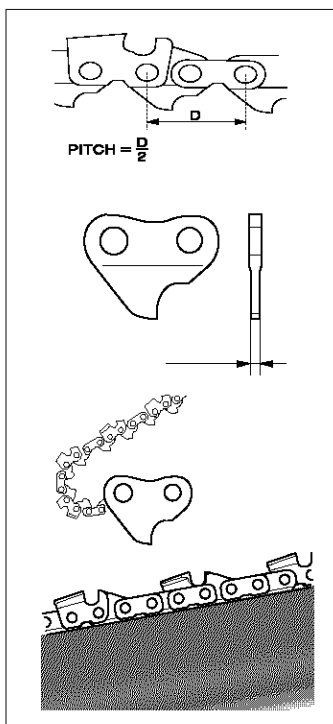

FILE POSITION

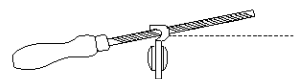

ROUND FILE DIA- METER

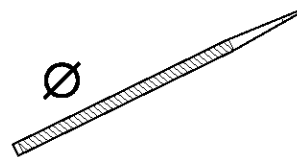

FILE DEPTH

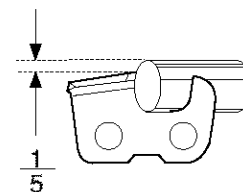

Sharpening your chain and adjusting raker clearance

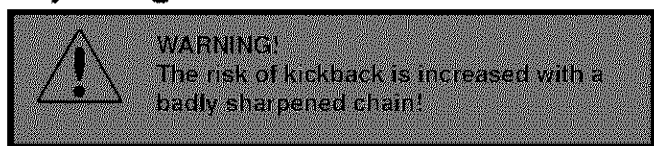

A. General information on sharpening cutting teeth

- Never use a blunt chain. When the chain is blunt you have to exert more pressure to force the bar through the wood and the cuttings will be very small. If the chain is very blunt it will not produce any cuttings at all, just wood powder.
- A sharp chain eats its way through the wood and produces long, thick cuttings.
- The cutting part of the chain is called the CUTTING LINK and this consists of a CUTTING TOOTH (A) and the RAKER LIP (B). The cutting depth is determined by the difference in height between the two.
- When you sharpen a cutting tooth there are five important factors to remember:

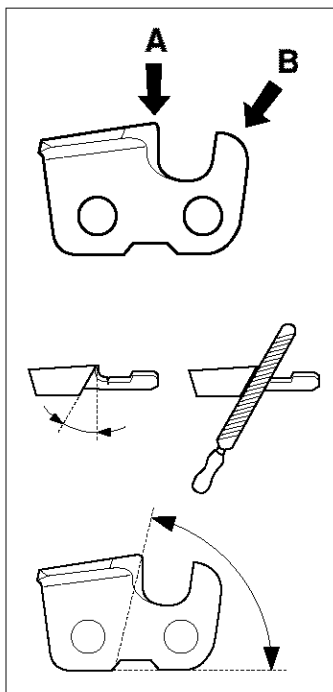

FILING ANGLE

CUTTING ANGLE

It is very difficult to sharpen a chain correctly without the right equipment. We recommend you to use a file gauge. This will help you obtain the maximum kickback reduction and cutting performance from your chain.

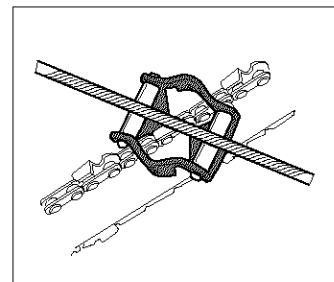

WARNING!
The following faults will increase the risk of kickback considerably.

- FILE ANGLE TOO LARGE
- CUTTING ANGLE TOO SMALL
- FILE DIAMETER TOO SMALL

The image contains three diagrams illustrating the faults. The top diagram shows a file being used to sharpen a cutting tooth with a large filing angle. The middle diagram shows a file being used to sharpen a cutting tooth with a small cutting angle. The bottom diagram shows a round file with a diameter symbol (Ø) indicating the diameter of the file.

SAFETY INSTRUCTIONS

B. Sharpening cutting tooth

To sharpen cutting teeth you will need a **ROUND FILE** and a **FILE GAUGE**.

1. Check that the chain is correctly tensioned. A slack chain is difficult to sharpen correctly.
2. Always file cutting teeth from the inside face, reducing the pressure on the return stroke. File all the teeth on one side first, then turn the machine over and file the teeth on the other side.
3. File all the teeth to the same length. When the length of the cutting teeth is reduced to 4 mm (.16") the chain is worn out and should be replaced.

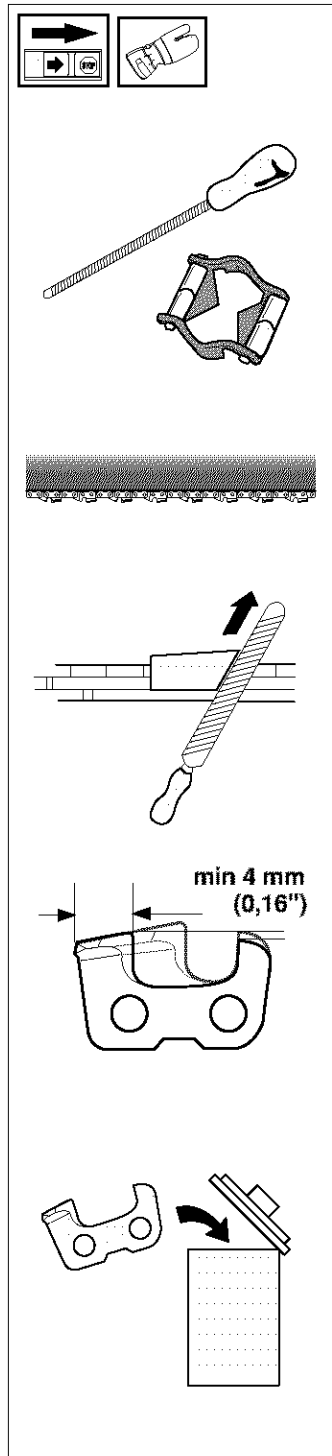

C. General advice on setting raker clearance

- When you sharpen the cutting teeth you reduce the **RAKER CLEARANCE** (cutting depth). To maintain cutting performance you must file back the raker teeth to the recommended height.
- On a low-kickback cutting link the front edge of the raker lip is rounded. It is very important that you maintain this radius or bevel when you adjust the raker clearance.
- We recommend the use of a raker gauge to achieve the correct clearance and bevel on the raker lip.

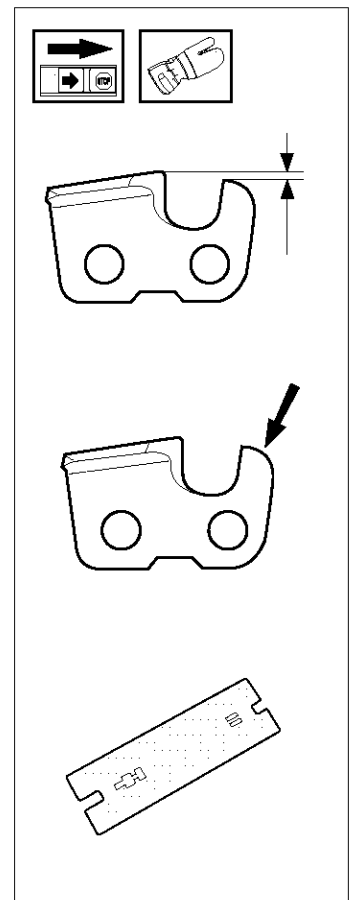

WARNING!

The risk of kickback is increased if the raker clearance is too large!

SAFETY INSTRUCTIONS

D. Adjusting raker clearance

- When correction of the raker clearance is made the teeth must be newly sharpened. We recommend that you adjust the raker clearance every third time you sharpen the chain. **NOTE!** This recommendation assumes that the length of the cutting teeth is not reduced excessively.
- A **FLAT FILE** and an **RAKER CLEARANCE GAUGE** are required to correct the raker clearance.
- Place the gauge over the raker lip.
- Place the file over the part of the lip that protrudes through the gauge and file off the excess. The clearance is correct when you no longer feel any resistance as you draw the file over the gauge.

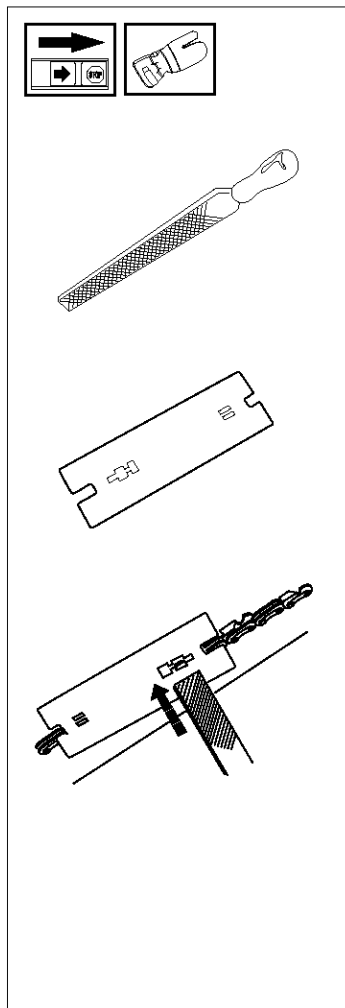

Tensioning the saw chain

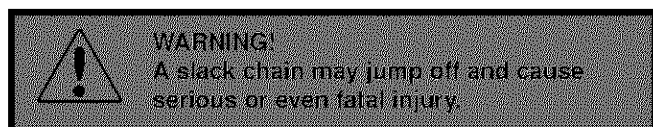

- The more you use a chain the longer it becomes. It is therefore important to adjust the chain regularly to take up the slack.
- Check the chain tension every time you refuel. **NOTE!** A new chain has a running-in period during which you should check and adjust the chain tension more frequently.
- As a rule the chain should be tensioned as tightly as possible, but not so tight that you cannot pull it round freely by hand.

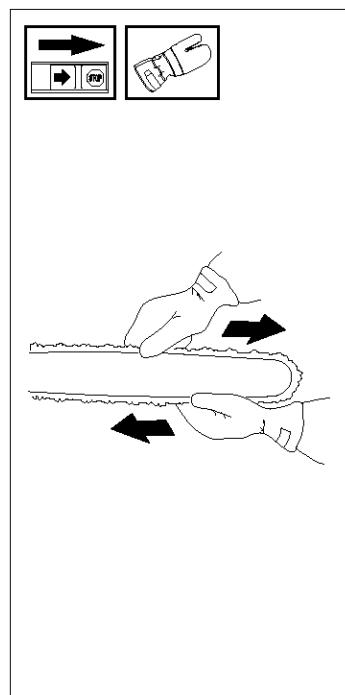

- Undo the bar nut.
- Tension the chain by turning the chain tensioning screw clockwise using the combination spanner. Tighten the chain until it no longer hangs slack beneath the bar.
- Use the combination spanner to tighten the blade nut while lifting the tip of the bar at the same time. Check that you can pull the chain round freely by hand.

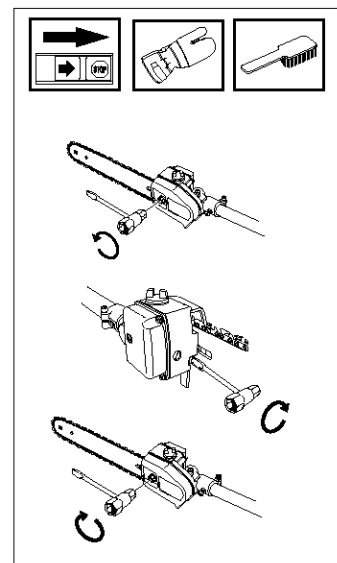

Lubricating cutting equipment

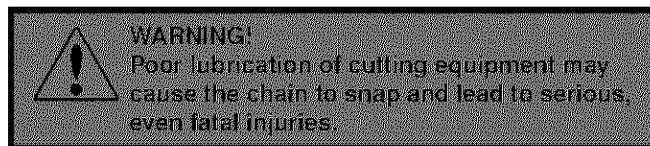

A. Chain oil

- Chainsaw chain oil must demonstrate good adhesion to the chain and also maintain its flow characteristics regardless of whether it is warm summer or cold winter weather.
- As a chainsaw manufacturer we have developed an optimal chain oil which, with its vegetable oil base, is also biodegradable. We recommend the use of our own oil for both maximum chain life and to minimise environmental damage.
- If our own chain oil is not available, standard chain oil is recommended.
- In areas where oil specifically for lubrication of saw chains is unavailable, ordinary EP 90 transmission oil may be used.
- Never use waste oil!**
This is dangerous for yourself, the saw and the environment.

B. Filling with chain oil

The oil pump is preset at the factory to meet most lubrication requirements and a full oil tank will last about half as long as a tank of fuel. You should therefore check the level in the oil tank regularly to avoid damaging the chain and bar by running out of oil.

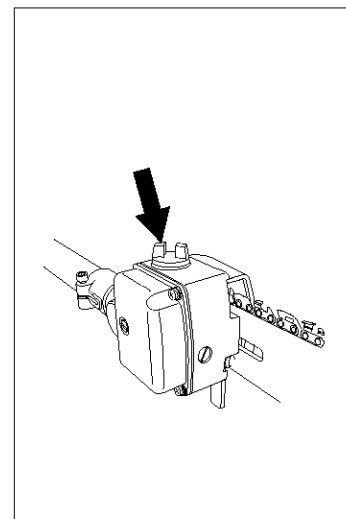

SAFETY INSTRUCTIONS

C. Checking chain lubrication

- Check the chain lubrication each time you refuel.
Aim the tip of the saw at a light coloured surface about 20 cm away. After 1 minute running at 3/4 throttle you should see a distinct line of oil on the light surface.

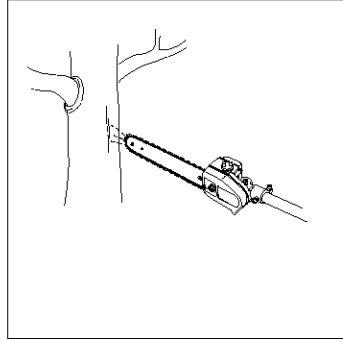

D. Adjusting chain lubrication

- When cutting dry or hard species of wood it may be necessary to increase lubrication. To increase the oil flow, first undo screw (A) then turn the adjuster screw (B) anticlockwise. Re-tighten screw (A). Remember that this will increase the oil consumption and you should therefore check the level in the oil tank more frequently.

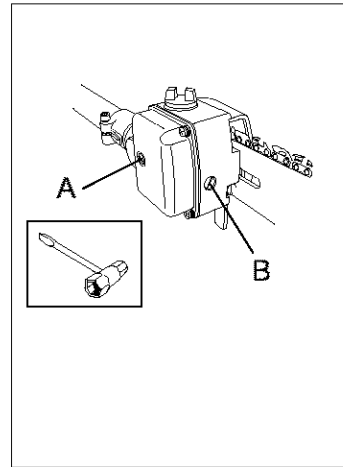

Procedure if the lubrication does not function:

- Check that the oil channel in the bar is not obstructed. Clean if necessary.
Check also that the O-ring is in position and is undamaged.
- Check that the oil channel in the gear housing is clean. Clean if necessary.
- Check that the bar tip sprocket turns freely. If the chain lubrication system is still not working after carrying out the above measures you should contact your service agent.

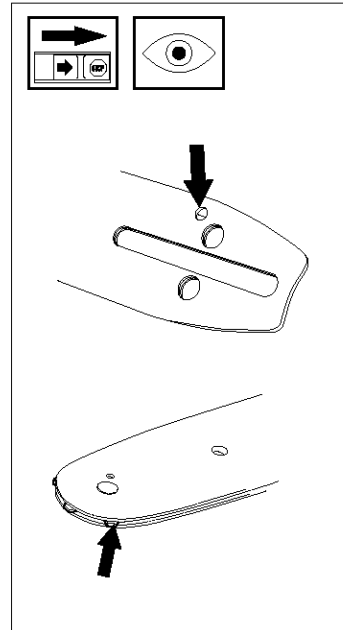

Checking wear on cutting equipment

A. Saw chain

Check the saw chain daily for:

- Visible cracks in rivets and links.
- Whether the chain is stiff.
- Whether rivets and links are badly worn.

Compare the existing chain with a new chain to decide how badly it is worn.

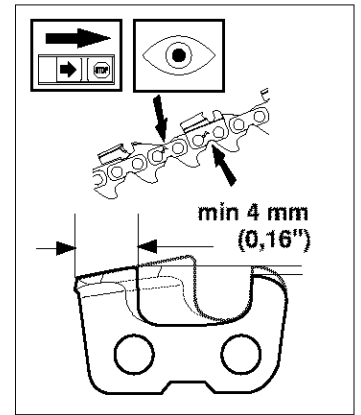

When the length of the cutting teeth has worn down to only 4 mm the chain must be replaced.

B. Chain drive wheel

Check regularly the degree of wear on the drive wheel. Change if it is irregularly worn.

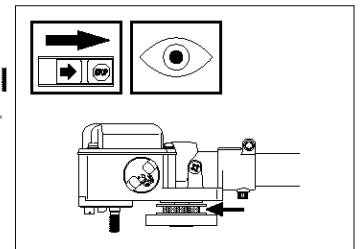

C. Vibration damping system

Check regularly that the vibration damper is free from cracks.

Check regularly the degree of wear on the rubber elements. Change if worn.

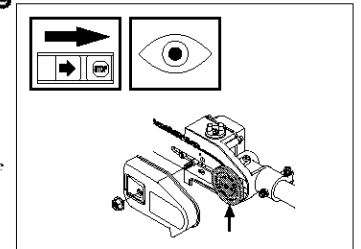

D. Guide bar

Check regularly:

- Whether there are burrs on the edges of the bar. Remove these with a file if necessary.
- Whether the groove in the bar has become badly worn. Replace the bar if necessary.
- Whether the tip of the bar is uneven or badly worn. If a hollow forms on one side of the bar tip this is due to a slack chain.
- To prolong the life of the bar you should turn it over daily.

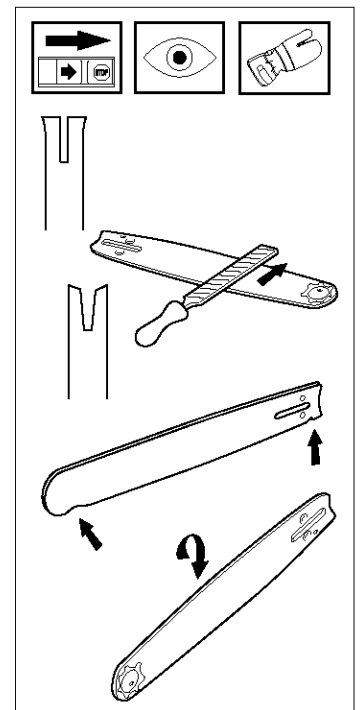

WARNING!
Using faulty cutting equipment may increase the risk of accidents.

SAFETY INSTRUCTIONS

General safety instructions

IMPORTANT INFORMATION

- The machine is only designed for tree pruning.
- The only accessories to be used with the engine unit as a drive source are the cutting units we recommend in the chapter "Technical data".
- Never use the machine if you are tired, if you have consumed alcohol, or if you are taking medicines that can affect your sight, your judgement or the control of your body.
- Use personal protective equipment. See the section "Personal protective equipment".
- Never use a machine that has been modified so that it no longer corresponds with the original design.
- Never use a machine that is faulty. Follow the maintenance, control and service instructions in this Operator's Manual. Some maintenance and service actions should be carried out by trained and qualified specialists. See the chapter "Maintenance".
- All covers and guards must be fitted before starting the machine. Check that the spark plug cap and HT lead are not damaged, otherwise you could get an electric shock.
- The machine operator shall ensure, while working, that no persons or animals come closer than 15 metres (50 feet). When several operators are working in the same area the safety distance should be at least double tree length, however, at least 15 metres (50 feet).



WARNING!
Faulty cutting equipment increases the risk of accidents.

Start



WARNING!
When the engine is started with the choke in either the choke or start throttle positions, the cutting equipment starts to move immediately.

- The complete clutch cover with shaft must be fitted before the machine is started, otherwise the clutch can become loose and cause personal injury.
- Never start the machine indoors. Bear in mind the dangers of inhaling the engine's exhaust fumes.
- Observe your surroundings and make sure that there is no risk of people or animals coming into contact with the cutting equipment.

- Place the machine on the ground, ensure the cutting equipment runs free of twigs and stones. Push the machine body towards the ground using your left

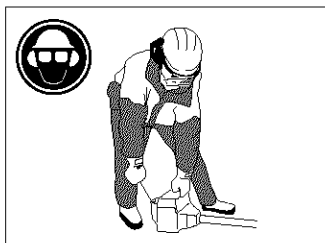

hand. (NOTE! Not with your foot). Grip the starter handle with your right hand and pull the starter cord.

Fuel safety

- Always use a fuel container with an anti-spill valve.
- Never fill the machine while the engine is running. Always stop the engine and let it cool for a few minutes before refuelling.
- Provide good ventilation when filling or mixing fuel (petrol and 2-stroke oil).
- Move the machine at least 3 m from the filling position before starting.
- Never start the machine:
 - a) If you have spilt fuel on it. Wipe up all spillage.
 - b) If you have spilt fuel on yourself or your clothes. Change your clothes.
 - c) If there is a fuel leak. Make regular checks for leakage from the fuel cap and the fuel supply pipes.



Min. 3 m
(10 ft)

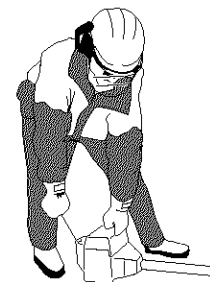

Transport and storage

- Store and transport the machine and fuel so that any leakage or fumes do not risk coming into contact with sparks or naked flames. For example, electric machines, electric motors, electrical switches/power switches, heaters or the like.
- When storing and transporting fuel approved containers intended for this purpose must be used.
- When storing the machine for long periods the fuel tank must be emptied. Contact your local petrol station to find out how to dispose of excess fuel.



WARNING!
Exercise great care when handling fuel and chain oil. Bear in mind the risk of fire, explosions and inhaling fumes.

- If the machine is to be transported on a vehicle, it must be secured to avoid damage or fuel leakage. You should also make sure that the machine cannot injure any person or animal during transport. Observe relevant traffic regulations.
- The transport guard must be fitted during transport and storage.

SAFETY INSTRUCTIONS

Safety instructions when using the machine



WARNING!
The machine can cause serious injury.
Read the safety instructions carefully.
Learn how to use the machine.



WARNING!
Cutting tool. Do not touch the tool
without first switching off the engine.

NOTE! Read the Operator's Manual carefully before using the machine.

Personal protection

- Always wear boots, and the other safety equipment described in the section "Personal protective equipment".
- Always wear working clothes and thick, long trousers.
- Never wear loose fitting clothes or jewellery
- Secure hair so it is above shoulder level.

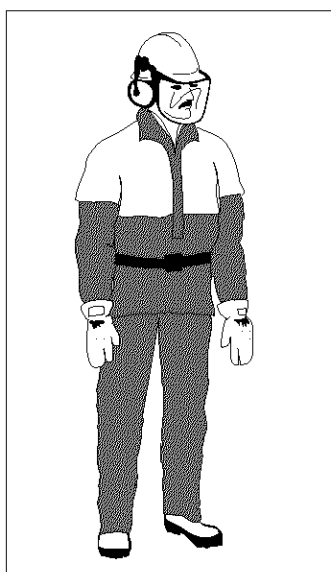

Protective instructions regarding the surroundings

- Never allow children to use the machine.
- Ensure no one comes within 15 metres while working.
- Never allow anyone to use the machine without first being absolutely sure that they understand the contents of the Operator's Manual.
- Never work on a ladder, stool or any other raised position that is not fully secured.

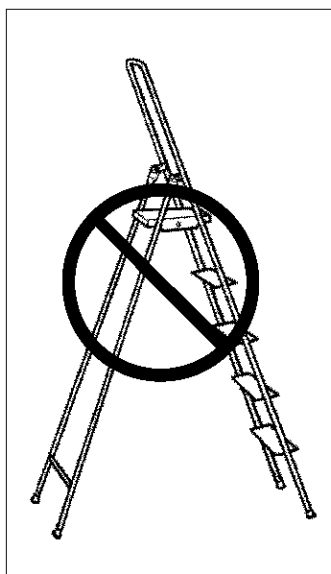

Protective instructions while working

- Always ensure you have a safe and firm working position.
- Always use both hands to hold the machine. Hold the machine on the side of the body.
- Use your right hand to operate the throttle.
- Make sure that your hands and feet cannot come into contact with the cutting equipment when the engine is running.
- When the engine is switched off, keep your hands and feet away from the cutting equipment until it has stopped.
- Watch out for stumps of branches that can be thrown out during cutting.
- Always lay the machine on the ground when you are not using it.



- Check the working area for foreign objects such as electricity cables, insects and animals, etc, and for other objects that could damage the cutting attachment, such as metal items.
- If any object is hit or if vibrations occur stop the machine immediately. Remove the spark plug cable from the spark plug. Check that the machine is not damaged. Repair any damage.
- If anything gets caught up in the cutting equipment while you are working, switch off the engine and wait for it to stop completely before cleaning the cutting equipment. Remove the spark plug cable from the spark plug.

SAFETY INSTRUCTIONS

Protective instructions when work is completed

- The transport guard should always be fitted to the cutting equipment when the machine is not in use.
- Ensure the cutting equipment has stopped and remove the spark plug cable from the spark plug before carrying out clearing, repairs or an inspection.
- Always wear heavy duty gloves when repairing the chain. The cutting equipment is extremely sharp and can easily cause cuts.
- Store the machine out of reach from children.
- Only use original spare parts when carrying out repairs.

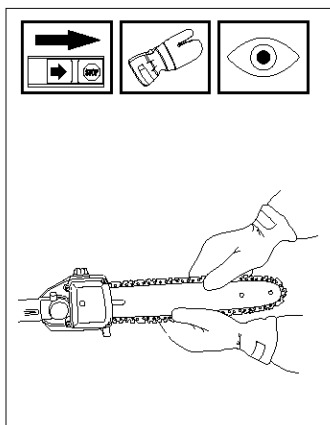

Basic working techniques

- The machine should be held as close to the body as possible to get the best balance.
- Make sure that the tip does not touch the ground.
- Do not rush the work, but work steadily until all the branches have been cut back cleanly.
- Always drop to idling speed after each working operation. Longer periods running at full throttle without loading the engine can lead to serious engine damage.
- Always cut with the engine at full throttle.
- Let the engine drop back to idle between each cut. Long periods at full throttle can cause serious damage to the centrifugal clutch.

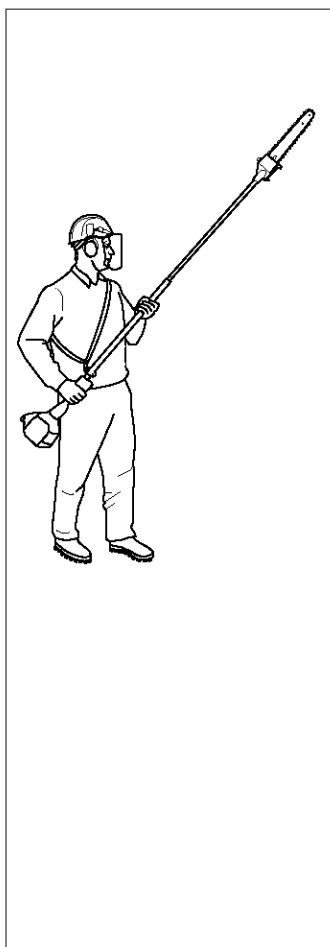

Observe great care when working close to overhead power lines. Falling branches can result in short-circuiting.

WARNING!
Observe the applicable safety regulations for work in the vicinity of overhead power lines.

WARNING!
This machine is not electrically insulated. If the machine touches or comes close to live electricity lines, it could cause death or serious injury. Electricity can jump from one point to another in the form of a high-voltage arc. The higher the voltage, the further the electricity can jump. Electricity can also be conducted by branches and other objects, especially if they are wet. Always keep a distance of at least 10 m (30 ft) between the machine and live electricity lines and or objects that are touching them. If you have to work closer than this, always contact the relevant power company to make sure the power is switched off before you start your work.

WARNING!
This machine has a long reach. Make sure that no people or animals come closer than 15 m (45 ft) when the machine is running.

- Whenever possible position yourself so that you can make the cut at right angles to the branch.
- Do not work with the shaft held straight out in front of you (like a fishing rod). This increases the apparent weight of the cutting equipment.
- Cut large branches in stages to give better control over where they fall.
- Never cut through the swelling at the root of the branch as this will slow down healing and increase the risk of fungal attack.

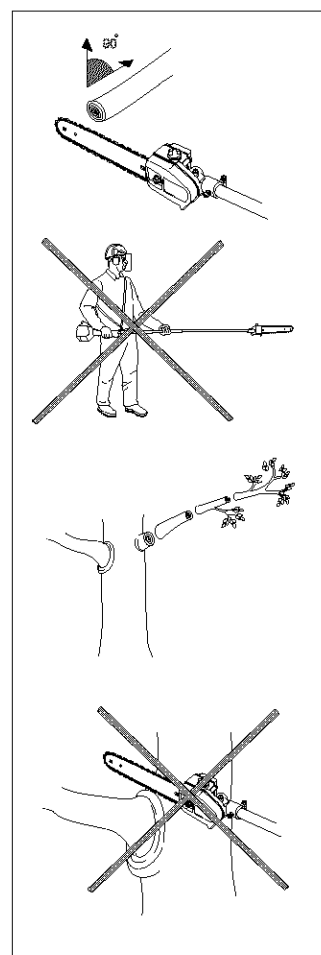

WARNING!
Never stand directly underneath a branch that is being cut, otherwise you may suffer serious or even fatal injury.

SAFETY INSTRUCTIONS

- Use the stop at the base of the bar to provide support during cutting. This will help prevent the cutting equipment from jumping on the branch.
- Make an initial cut on the underside of the branch before cutting through the branch from above. This will prevent tearing of the bark, which could lead to slow healing and cause permanent damage to the tree. The first cut should not be deeper than 1/3 of the branch thickness to prevent jamming. Keep the chain running while you withdraw the cutting equipment from the branch to prevent it jamming.
- Use the harness to support the weight of the machine and make it easier to handle.
- Make sure you have a firm footing and will not be hampered by branches, stones and other trees.

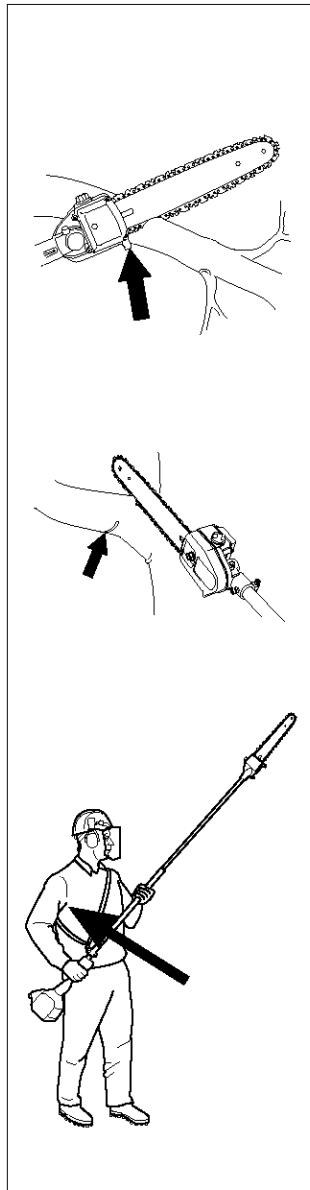

WARNING!
Never use the throttle without having a full view of the cutting equipment.

WHAT IS WHAT?

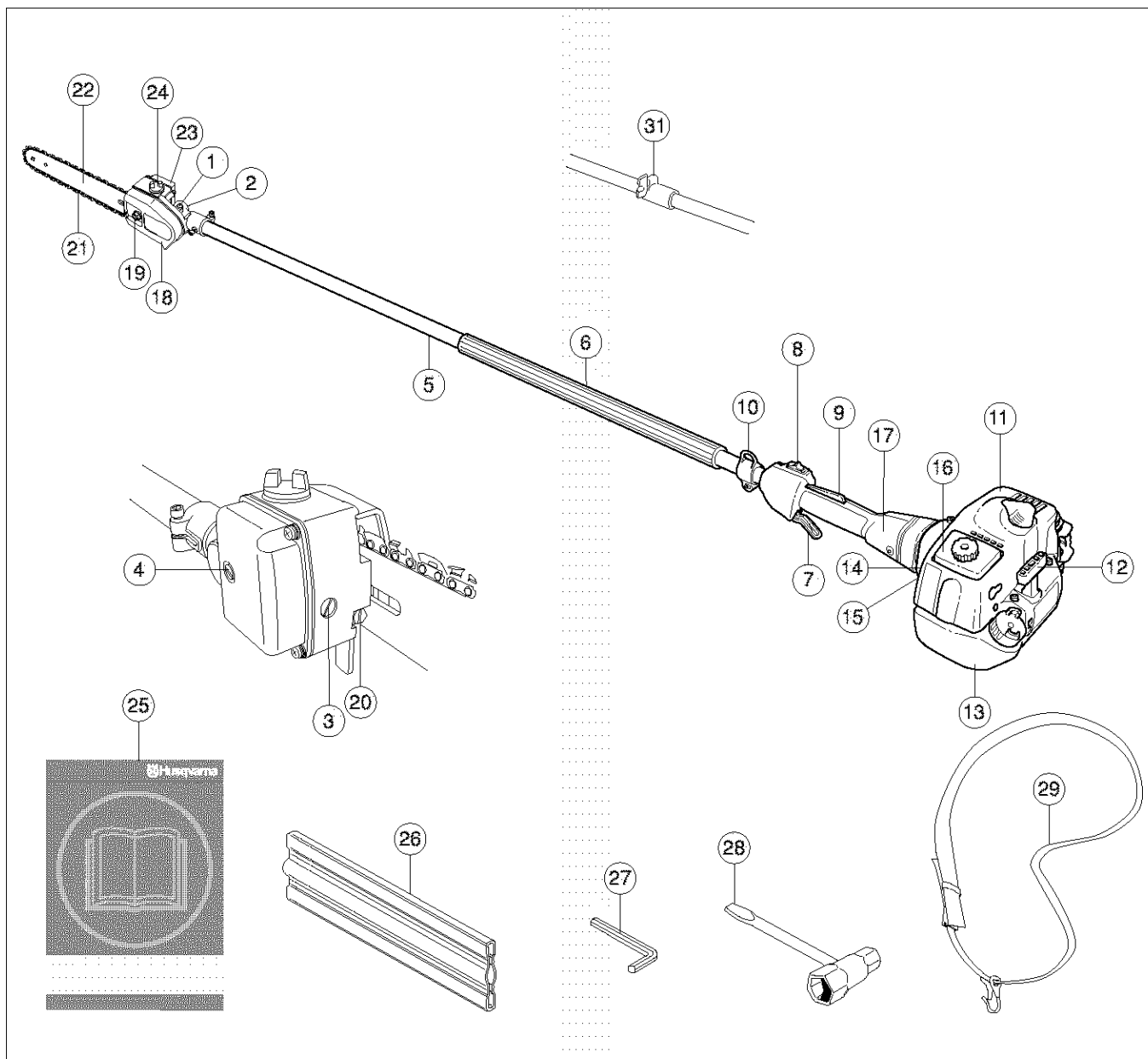

What is what on the machine?

- | | |
|---|--|
| 1. Lubricant filler hole | 17. Clutch cover |
| 2. Bevel gearbox | 18. Chain guard |
| 3. Chain lubrication adjustment screw (B) | 19. Bar nut |
| 4. Chain lubrication locking screw (A) | 20. Chain tensioning screw |
| 5. Shaft | 21. Chain |
| 6. Front handle | 22. Bar |
| 7. Throttle control | 23. Chain oil tank |
| 8. Stop switch | 24. Chain oil filler hole |
| 9. Throttle lock | 25. Operator's manual |
| 10. Hook for harness | 26. Transport guard |
| 11. Cylinder cover | 27. Allen key |
| 12. Starter handle | 28. Combination spanner |
| 13. Fuel tank | 29. Harness |
| 14. Choke control | 31. Shaft coupling (326P5 _{326P5}) |
| 15. Fuel pump | |
| 16. Air filter cover | |

Fitting the cutting head

- Fit the cutting head on the shaft so that the screw (A) is aligned with the hole in the shaft as shown.
- Tighten screw A.
- Tighten screw B.

NOTE! Make sure that the drive shaft inside the shaft engages with the cut-out in the cutting head.

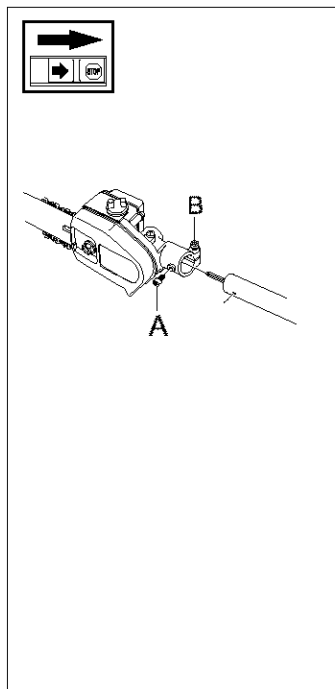

Mounting guide bar and chain

- Unscrew the bar nut and remove the guard.
- Fit the bar over the bar bolt. Place the bar in its rearmost position. Place the chain over the drive sprocket and in the groove on the bar. Begin on the top side of the bar.
- Make sure that the edges on the cutting links are facing forward on the top side of the bar.
- Fit the clutch cover and locate the chain adjuster pin in the hole on the bar. Check that the drive links of the chain fit correctly on the drive sprocket and that the chain is in the groove on the bar. Tighten the bar nut finger tight.
- Tension the chain by using the combination wrench. Turn the chain adjuster screw clockwise. The chain should be tensioned until it fits snugly on the underside of the bar.

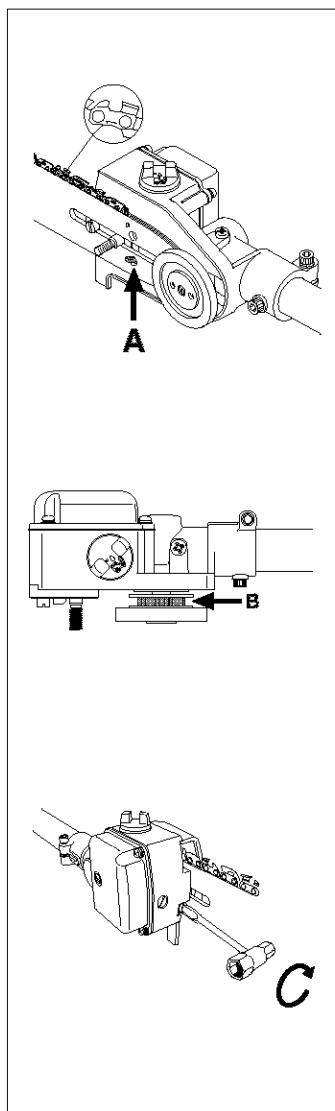

- The chain is correctly tensioned when there is no slack on the underside of the bar, but it can still be turned easily by hand. Hold up the bar tip and tighten the bar nuts with the combination wrench.
- When fitting a new chain, the chain tension has to be checked frequently until the chain is run-in. Check the chain tension regularly. A correctly tensioned chain gives good cutting performance and long lifetime.

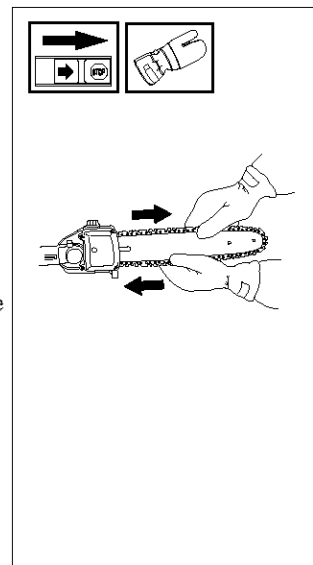

Adjusting the harness

You should always use the harness with the machine to give maximum control and reduce strain on your arms and back.

1. Put on the harness.
2. Hook the machine onto the hook on the harness.
3. Adjust the length of the harness so that the hook is roughly level with your right hip.

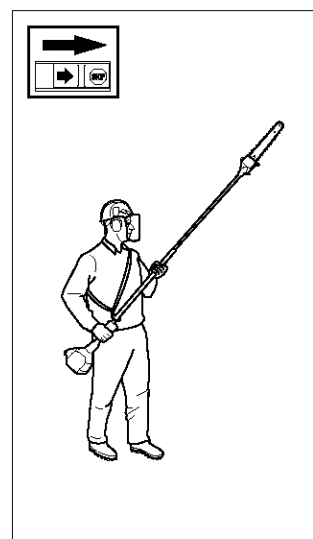

Filling with oil

- Open the cap on top of the cutting head.
- Fill with Husqvarna Chain Oil.
- Refit the cap.

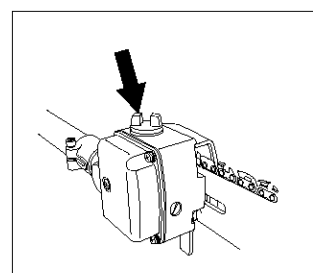

Assembling and dismantling the two-part shaft (326P5)

Assembling:

- Make sure the handle is loose.
- Guide the cut-out on the lower section of the shaft into the coupling's locking plate on the upper section of the shaft. The sections are then locked together.
- Tighten the handle.

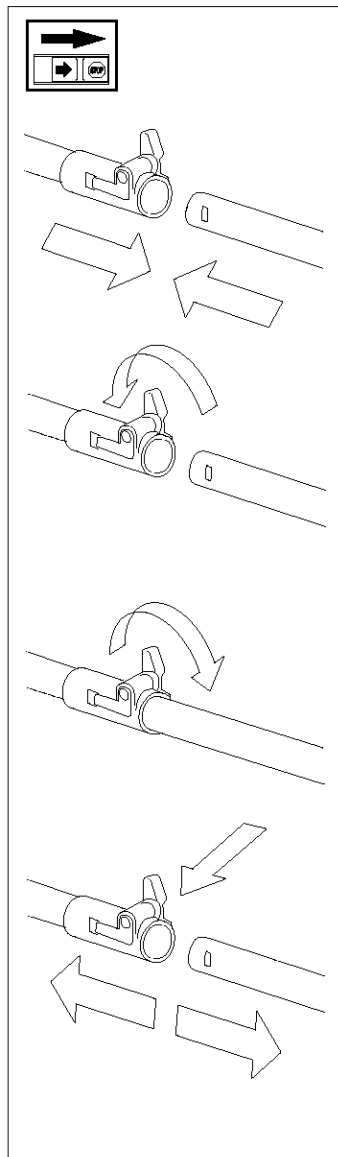

Dismantling

- Undo the handle (at least three turns).
- Press the handle towards the coupling.
- Carefully twist the lower section out of the lock.
- Hold both parts of the shaft and pull out the lower section from the coupling.

FUEL HANDLING

Fuel mixture

NOTE!

The machine is fitted with a two-stroke engine and must always be run on a mixture of gasoline and two-stroke oil. It is important to measure the quantity of oil accurately, to ensure the correct mixture ratio. Small discrepancies in the amount of oil have a great bearing on the proportions of the fuel mixture when mixing small amounts of fuel.

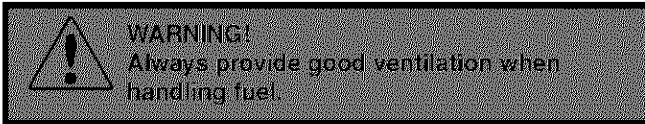

Gasoline

NOTE!

Always use high grade unleaded oil mixed gasoline (minimum 87 RON). Leaded fuel will destroy the catalytic converter and it will no longer serve its purpose.

- This engine is certified to operate on unleaded gasoline.
- The lowest recommended octane rating is 87. If you run the engine on lower octane rating than 87 so-called "knocking" can occur. This leads to an increased engine temperature, which can result in a serious engine breakdown.
- When working at continuous high revs a higher octane rating is recommended.

Two-stroke oil

- For the best results use HUSQVARNA two-stroke oil, which has been specially developed for clearing saws and chain saws. Mixing ratio 1:50 (2%).
- Never use two-stroke oil intended for water cooled outboard motors, so-called outboard motor oil.
- Never use oil intended of four-stroke engines.

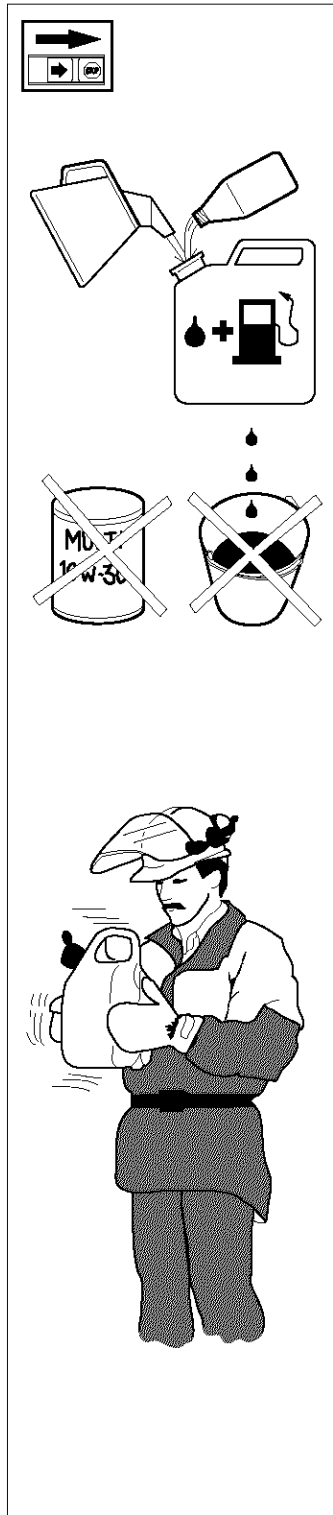

Mixture

- Always mix gasoline and oil in a clean container intended for fuel.
- Always start by filling half the quantity of gasoline required. Then add the entire oil quantity. Mix (shake) the fuel mixture. Fill the remaining quantity of gasoline.
- Mix (shake) the fuel mixture carefully before filling in the machine's fuel tank.
- Do not mix more than max. one month's supply of fuel.
- If the machine is not used for a long period of time, the fuel tank should be emptied and cleaned.
- This engine is certified to operate on unleaded gasoline.

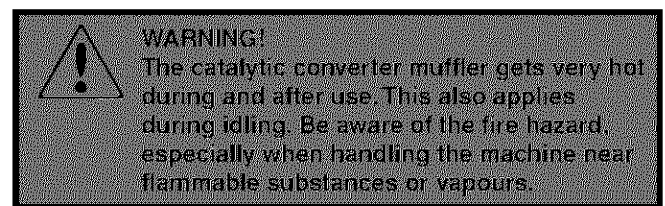

Fuelling

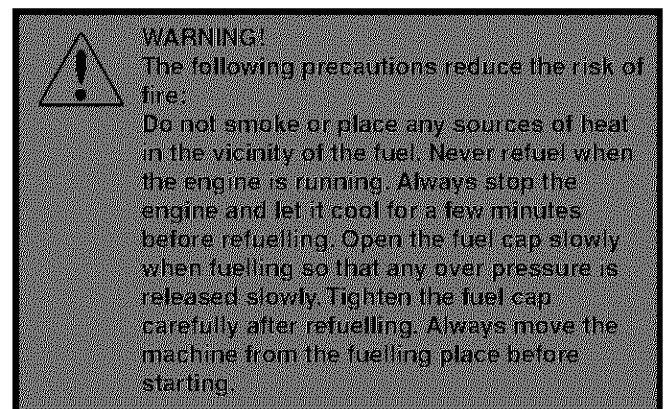

- Clean around the fuel cap. Contamination in the tank can disrupt operations.
- Ensure that the fuel is well mixed by shaking the container before filling the tank.

Gasoline	Oil 2%(1:50)
Lit.	Lit.
5	0,10
10	0,20
15	0,30
20	0,40
US gallon	US fl. oz.
1	2 1/2
2 1/2	6 1/2
5	12 7/8

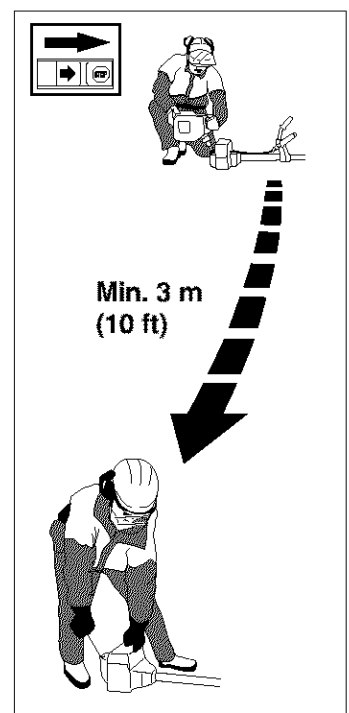

START AND STOP

Control before starting

- Inspect the working area. Remove objects that can be thrown.
- Check the cutting-equipment. Never use blunt, cracked or damaged equipment.
- Check that the machine is in full working order. Check that all nuts and bolts are tightened correctly.
- Make sure the chain is always well lubricated.
- Ensure the cutting equipment always stop when the engine is idling.
- Only use the machine for what it is intended for.
- Ensure that the handle and safety functions are in order. Never use a machine that lacks a part or has been modified outside of the specifications.

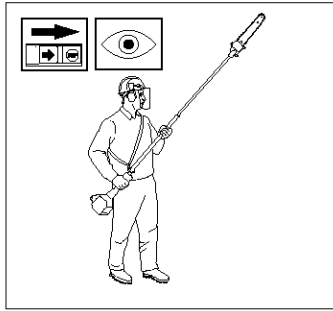

Stop

The engine is stopped by switching off the ignition.

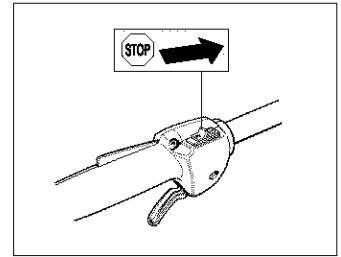

WARNING!

When the engine is started with the choke in the choke or start position the cutting equipment starts to rotate immediately.

Start and stop



WARNING!

The complete clutch cover with shaft must be fitted before the machine is started, otherwise the clutch can become loose and cause personal injury.

Always move the machine from the filling area before starting. Place the machine on a flat surface. Ensure the cutting equipment cannot come into contact with any object. Make sure no unauthorised persons are in the working area, otherwise there is a risk of serious personal injury. The safety distance is 15 metres.

Cold engine

IGNITION:

Set the stop switch to the start position.

CHOKE:

Set the choke control in the choke position.

AIR PURGE:

Press the air purge diaphragm repeatedly until fuel begins to fill the diaphragm. The diaphragm need not be completely filled.

Warm engine

Use the same starting procedure as for the cold engine, but do not set the choke control in the choke position. The start throttle position is obtained by setting the choke control in the choke position and then returning it to its original position.

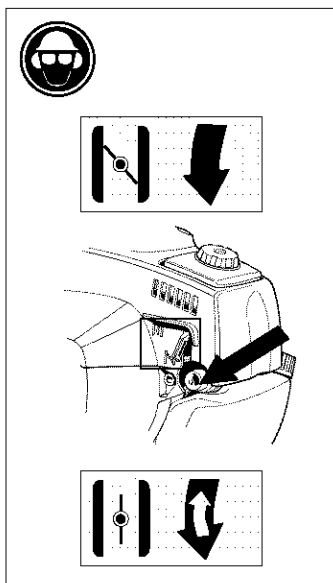

Start

Press the machine body against the ground using your left hand (NOTE! Not your foot). Grip the starter handle, slowly pull out the cord with your right hand until you feel some resistance (the starter pawls grip), now quickly and powerfully pull the cord.

Reset the choke control as soon as the engine fires and repeat until the engine starts. When the engine starts quickly apply full throttle and the start throttle will automatically disengage.

NOTE! Do not pull the starter cord out completely and do not release the starter cord from the fully extended position. This can damage the machine. Also take care to ensure that the cutting attachment is not touching the ground when you start the machine.

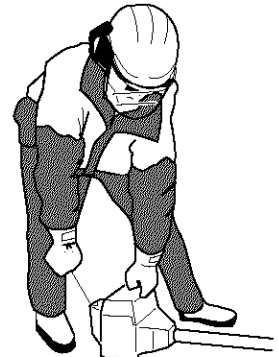

Carburetor

Your Husqvarna product has been designed and manufactured to specifications that reduce harmful emissions. After your unit has been run 8-10 tanks of fuel the engine has broken in. To ensure that your unit is at peak performance and producing the least amount of harmful emissions after break in, have your authorized servicing dealer, who has a revolution counter at his disposal, to adjust your carburetor for optimum operating conditions.



WARNING!

The complete clutch cover with shaft must be fitted before the machine is started, otherwise the clutch can become loose and cause personal injury.

Operation

- The carburetor governs the engine's speed via the throttle. Air/fuel is mixed in the carburetor. The air/fuel mixture is adjustable. To take advantage of the engine's optimal output the adjustment must be correct.
- The setting of the carburetor means that the engine is adapted to local conditions, for example, the climate, altitude, gasoline and the type of 2-stroke oil.
- The carburetor is equipped with three adjustment possibilities:
 - L = Low speed needle
 - H = High speed needle
 - T = Idle speed adjuster screw
- The fuel quantity in relation to the air flow permitted by the throttle opening is adjusted using the L and H-needles. Turning the needles clockwise gives a leaner fuel mixture (less fuel) and turning them anti-clockwise gives a richer fuel mixture (more fuel). A leaner mixture gives high revs while a richer mixture give less revs.
- The T-screw regulates the position of the throttle while the engine is idling. Turning the screw clockwise gives a higher idling speed while turning it anti-clockwise gives a lower idling speed.

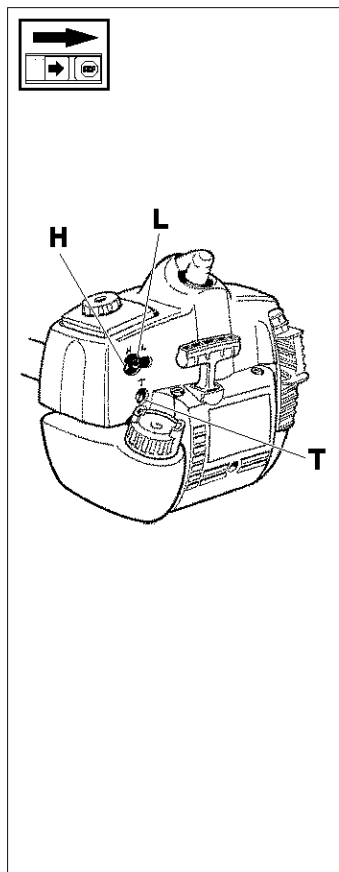

Basic setting

- The carburetor is set to its basic setting when test run at the factory. The basic setting should be kept during the machine's first working hours. Thereafter the carburetor should be finely adjusted. Fine adjustment should be carried out by a skilled technician.

NOTE! If the cutting attachment rotates/moves while the engine is idling the T-screw should be turned anti-clockwise until the cutting attachment stops.

Rec. idling speed: 2 700 rpm.

Recommended max. speed: See "Technical Data".



WARNING!

If the idling speed cannot be adjusted so that the cutting equipment stops, contact your service workshop. Do not use the machine until it has been correctly adjusted or repaired.

Fine adjustment

- When the machine has been "run-in" the carburetor should be finely adjusted. The fine adjustment should be carried out by qualified person. First adjust the L-jet, then the idling screw T and then the H-jet.

Conditions

- Before any adjustments are made the airfilter should be clean and the airfilter cover fitted. Adjusting the carburetor while a dirty airfilter is in use will result in a leaner mixture when the filter is finally cleaned. This can give rise to serious engine damage.
- Carefully turn the L and H needle to the mid point between fully turned in and fully turned out..
- Do not attempt to adjust the needles beyond the stops as damage can occur.
- Now start the machine according to the starting instructions and run it warm for 10 minutes.

NOTE! If the cutting attachment rotates/moves the T screw should be turned anti-clockwise until the cutting attachment stops.

Low speed needle L

Try to find the highest idling speed, turning the low speed needle L clockwise respectively counter-clockwise. When the highest speed has been found, turn the low speed needle L 1/4 turn counter-clockwise.

NOTE! If the cutting-equipment rotates/moves in the idling position, turn the idling speed screw T counter-clockwise until the cutting attachment stops.

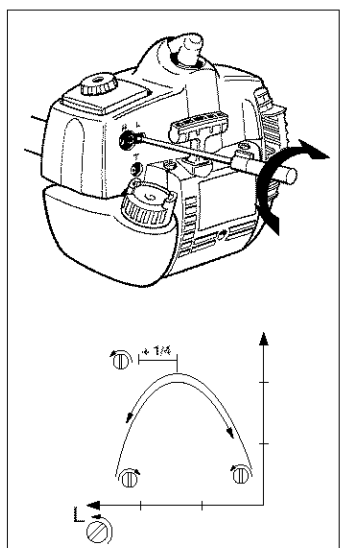

MAINTENANCE

Final setting of the idling speed T

Adjust the idling speed with the screw T, if it is necessary to readjust. First turn the idle speed adjusting screw T clockwise until the cutting equipment starts to rotate/move.

Then turn, counter-clockwise until the cutting equipment stops. A correctly adjusted idle speed setting occurs when the engine runs smoothly in every position. It should also be good margin to the rpm when the cutting equipment starts to rotate/move.

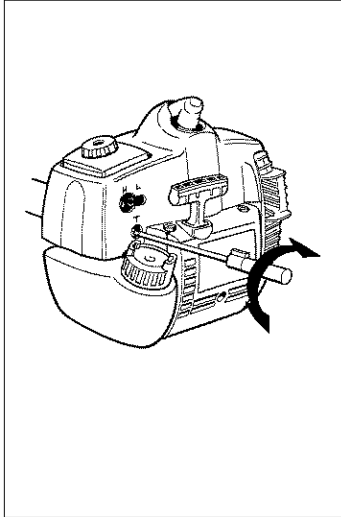

CAUTION! Contact your servicing dealer, if the idle speed setting cannot be adjusted so that the cutting attachment stops. Do not use the machine until it has been properly adjusted or repaired.

High speed needle H

The high speed needle affects the machine's power, speed, temperature and fuel consumption. A too lean adjustment on the high speed needle H (the high speed needle H is screwed in too much) gives a too high speed resulting in engine damage. Do not allow the engine to run at full speed for more than 10 seconds. Apply full throttle and turn the high speed needle H slowly anticlockwise until the engine runs unevenly. The high speed needle H is then turned slowly clockwise a little until the engine runs smoothly. Note the engine should be run unloaded when adjusting the high speed needle. The high speed needle is adjusted correctly when the machine 'splatters' a little .

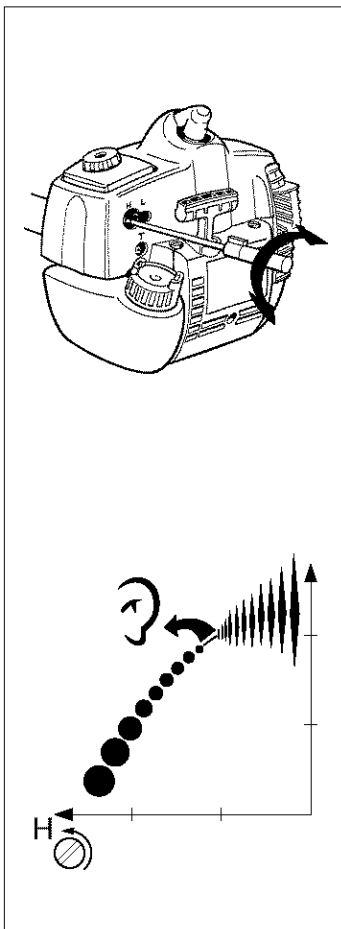

NOTE! For optimum setting of the carburetor, contact a qualified servicing dealer who has a revolution counter at his disposal.

Correctly adjusted carburetor

A correctly adjusted carburetor means that the machine accelerates without hesitation and the machine 4-cycles a little at max speed. Furthermore, the cutting equipment, must not rotate/move at idling. A too lean adjusted low speed needle L may cause starting difficulties and bad acceleration.

A too lean adjusted high speed needle H gives lower power = less capacity, bad acceleration and/or damage to the engine.

A too rich adjustment of the two speed needles L and H gives acceleration problems or too low working speed.

Muffler

NOTE!

Some mufflers are fitted with a catalytic converter. See "Technical data" to see whether your machine is fitted with a catalytic converter.

The muffler is designed to dampen the noise level and to direct the exhaust fumes away from the user. The exhaust fumes are hot and can contain sparks, which can result in fire if the exhaust fumes are directed towards a dry and inflammable material. Some mufflers are equipped with a special spark arrest screen. If your machine is fitted with this type of screen it should be cleaned regularly. This is done using a wire brush. On mufflers without a catalytic converter the screen should be cleaned weekly, or replaced if necessary. On mufflers fitted with a catalytic converter the screen should be checked and cleaned monthly. **If the screen is damaged it should be replaced.** If the screen is frequently blocked, this can be a sign that the function of the catalytic converter is impaired. Contact your dealer to inspect the muffler. A blocked screen will cause the engine to overheat resulting in damage to the cylinder and piston. Also see under "Maintenance".

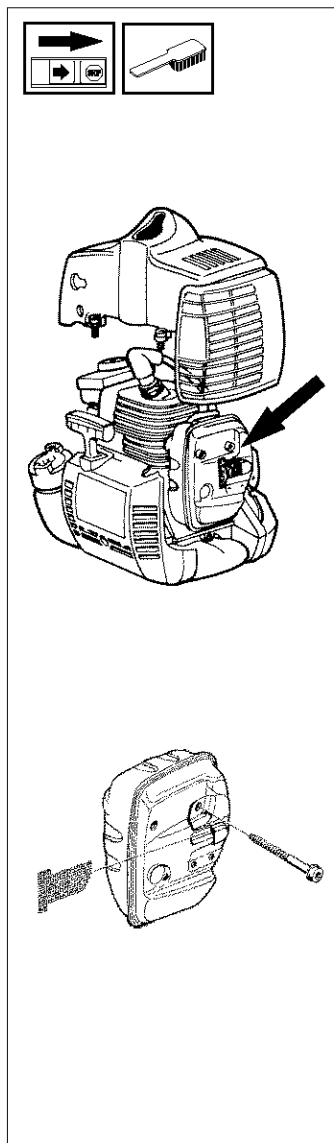

NOTE!

Never use a machine with a defective muffler.

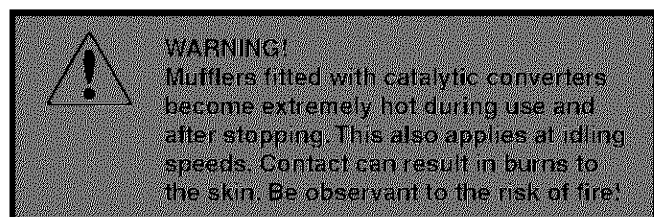

Cooling system

To maintain as low operating temperature as possible the engine is equipped with a cooling system.

The cooling system consists of:

1. An air intake on the starter unit.
2. Cooling fins on the flywheel.
3. Cooling fins on the cylinder
4. Cylinder cover (leads cold air onto the cylinder).

Clean the cooling system using a brush at least once a week, in difficult conditions more often.

A dirty or blocked cooling system leads to the engine overheating resulting in damage to the cylinder and piston.

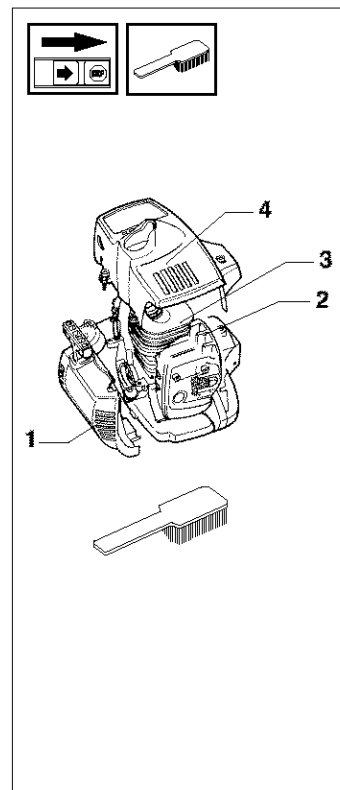

Spark plug

The condition of the spark plug is affected by:

- An incorrect carburetor setting.
- An incorrect fuel mixture (too much or faulty oil).
- A dirty air filter.

These factors cause deposits on the spark plug electrode that may result in malfunction or starting difficulties.

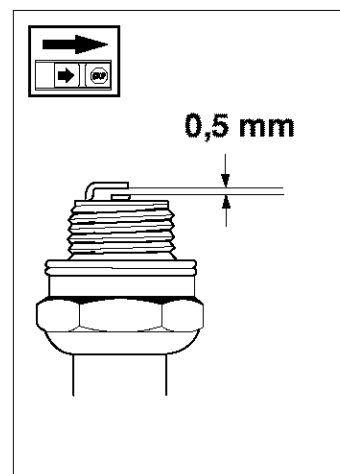

If the machine is low on power, difficult to start or runs poorly while idling always check the spark plug first.

If the spark plug is dirty, clean it and at the same time check that the electrode gap is 0.5 mm. The spark plug should be changed after about one month of operation or earlier if necessary.

NOTE! Always use the recommended type of spark plug. An incorrect spark plug can damage the cylinder/piston.

Air filter

The air filter should be cleaned regularly removing dust and dirt to avoid:

- carburetor malfunction
- starting problems
- reduced engine power
- unnecessary wear to engine parts
- abnormal fuel consumption

Clean the filter after every 25 hours or more regularly if operating conditions are exceptionally dusty.

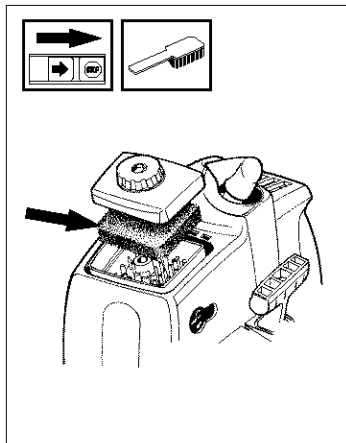

Cleaning the air filter

Dismantle the air filter cover and remove the air filter. Wash in clean, warm soapy water. Ensure that the filter is dry before refitting. An air filter used for a long period of time can never be cleaned completely. Therefore it is necessary to replace the filter from time to time with a new filter. A damaged air filter must always be replaced.

If the machine is used in dusty conditions the air filter should be soaked in oil, see the section on "Oiling the air filter".

Oiling the air filter

Always use HUSQVARNA filter oil, order no. 503 47 73-01. The filter oil contains a solvent to make it spread evenly through the filter. You should therefore avoid skin contact. Put the filter in a plastic bag and then pour the filter oil over it. Knead the plastic bag to distribute the oil. Squeeze the excess oil out of the filter inside the plastic bag and pour off the excess before fitting the filter on the machine. Never use common engine oil. This would drain through the filter quite quickly and collect in the bottom.

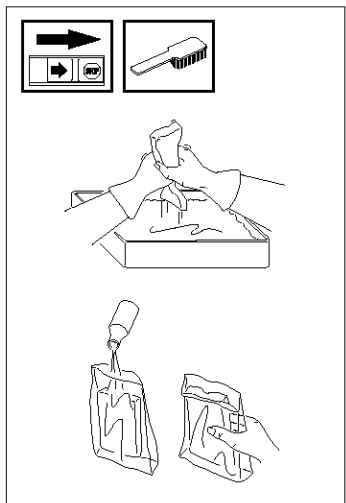

NOTE: Use only HUSQVARNA replacement parts. Use of other brands of replacement parts can cause damage to your unit or injury to the operator or others. Your warranty does not cover damage or liability caused by the use of accessories and/or attachments not specifically recommended by HUSQVARNA.

Maintenance schedule

Below you will find some general maintenance instructions.

Daily maintenance

- Check throttle trigger and throttle trigger lockout function.
- Check stop switch function.
- Check that chain does not rotate at idling.
- Clean the exterior of the machine.
- Check that the harness is undamaged.
- Check that nuts and screws are sufficiently tightened.
- Check for fuel leaks.
- Clean the area under the protective cover.

Weekly maintenance

- Check the starter, especially cord and return spring.
- Clean the carburetor area.
- Clean the exterior of the spark plug.
- Remove it and check the electrode gap.
- Adjust it to 0,5 mm (.020"), or change the spark plug.
- Clean the cooling fins on the cylinder and check that the air intake at the starter is not clogged.
- Clean the air filter.
- Clean or replace the muffler's spark arrest screen (only mufflers without a catalytic converter).
- File off any burrs on the sides of the bar.

Monthly maintenance

- Clean the fuel tank.
- Clean the exterior of the carburetor and the space around it.
- Clean the fan and the space around it.
- Check fuel hose for cracks or other damage. Change if necessary.
- Change fuel filter in fuel tank.
- Check clutch, clutch spring and clutch drum for wear. Change if necessary.
- Check electrical wires and connections.
- Change the spark plug.
- Change the airfilter.
- Check and clean the muffler's spark arrest screen if necessary (only mufflers with a catalytic converter).

TECHNICAL DATA

Technical data	326P4	326P4 _{X-SERIES}	326P5 _{X-SERIES}
Engine			
Cylinder capacity, cu. in/cm ³	1,50/24,5	1,50/24,5	1,50/24,5
Cylinder bore, inch/mm	1,34/34	1,34/34	1,34/34
Stroke length, inch/mm	1,06/27	1,06/27	1,06/27
Recommended max. speed, rpm	12 500	12 500	12 500
Idling speed, rpm	2700	2700	2700
Max. engine output, acc. to ISO 8893	0,9kW/ 9000 rpm	0,9kW/ 9000 rpm	0,9kW/ 9000 rpm
Catalytic converter muffler	Yes	Yes	Yes
Speed-regulated ignition system	Yes	Yes	Yes
Ignition system			
Manufacturer/type of ignition system	Walbro MB	Walbro MB	Walbro MB
Spark plug	Champion RCJ 6Y	Champion RCJ 6Y	Champion RCJ 6Y
Electrode gap, inch/mm	0,02/0,5	0,02/0,5	0,02/0,5
Fuel lubrication system			
Manufacturer/type of carburetor	Zama C1Q	Zama C1Q	Zama C1Q
Fuel tank capacity, US pint/litres	1,06/0,5	1,06/0,5	1,06/0,5
Weight			
Weight without fuel, cutting tool and guard, Lbs/kg	11,9/5,4	11,9/5,4	13,7/6,2
Noise levels			
Equivalent noise pressure level at the user's ear, measured according to EN ISO 11680-1:	94	94	92
Vibration levels			
Vibration levels on the handles, measured according to EN ISO 11680-1, m/s ²			
When idling, left/right handles:	2,2/2,6	2,2/2,6	1,2/1,6
At max. speed, left/right handles:	6,6/7,5	6,6/7,5	8,6/7,6

TECHNICAL DATA

Bar and chain combinations

The following combinations are CE approved.

Length, inches	Bar		Chain
	Pitch, inches	Max. no of teeth on tip sprocket	
10	3/8	7 T	Husqvarna S 36/ Oregon 91 VG
12	3/8	7 T	Husqvarna S 36/ Oregon 91 VG
10	3/8	7 T	Oregon 90 SG
12	3/8	7 T	Oregon 90 SG

Type	Inch	Inch/mm	Inch/mm	Angle	Angle	Angle	Inch/mm	Inch/cm: dl
91 VG	3/8"	0,050"/1,3	5/32" /4,0	85°	30°	0°	0,025"/0,65	10"/25:40 12"/30:45
S 36	3/8"	0,050"/1,3	5/32" /4,0	85°	30°	0°	0,025"/0,65	10"/25:40 12"/30:45
90 SG	3/8"	0,028"/1,1	5/32" /4,0	85°	30°	0°	0,025"/0,65	10"/25:40 12"/30:45



YOUR WARRANTY RIGHTS AND OBLIGATIONS

The EPA (U.S. Environmental Protection Agency), CARB (California Air Resources Board) and Husqvarna Forest & Garden are pleased to explain the emissions control system warranty on your 2001 and later small off-road engine. In U.S., new small off-road engines must be designed, built and equipped to meet the federal or California stringent anti-smog standards. Husqvarna Forest & Garden must warrant the emission control system on your small off-road engine for the periods of time listed below provided there has been no abuse, neglect or improper maintenance of your small off-road engine. Your emission control system includes Parts such as the carburetor and the ignition system. Where a warrantable condition exists, Husqvarna Forest & Garden will repair your small off-road engine at no cost to you including diagnosis, parts and labor.

MANUFACTURER'S WARRANTY COVERAGE

The 2001 and later small off-road engines are warranted for two years. If any emission related part on your engine is defective, the part will be repaired or replaced by Husqvarna Forest & Garden.

OWNER'S WARRANTY RESPONSIBILITIES

As the small off-road engine owner, you are responsible for the performance of the required maintenance listed in your Owner's Manual. Husqvarna Forest & Garden recommends that you retain all receipts covering maintenance on your small off-road engine, but Husqvarna Forest & Garden cannot deny warranty solely for the lack of receipts or for your failure to ensure the performance of all scheduled maintenance. As the small off-road engine owner, you should, however, be aware that Husqvarna Forest & Garden may deny you warranty coverage if your small off-road engine or a part has failed due to abuse, neglect, improper maintenance or unapproved modifications.

You are responsible for presenting your small off-road engine to a Husqvarna Forest & Garden authorized servicing dealer as soon as a problem exists. The warranty repairs should be completed in a reasonable amount of time, not to exceed 30 days.

If you have any questions regarding your warranty rights and responsibilities, you should contact your nearest authorized servicing dealer or call Husqvarna Forest & Garden at 1-800-487-5963.

WARRANTY COMMENCEMENT DATE

The warranty period begins on the date small off-road engine is delivered.

LENGTH OF COVERAGE

Husqvarna Forest & Garden warrants to the initial owner and each subsequent purchaser that the engine is free from defects in materials and workmanship which cause the failure of a warranted part for a period of two years.

WHAT IS COVERED

REPAIR OR REPLACEMENT OF PARTS

Repair or replacement of any warranted part will be performed at no charge to the owner at an approved Husqvarna Forest & Garden servicing dealer.

If you have any questions regarding your warranty rights and responsibilities, you should contact your nearest authorized servicing dealer or call Husqvarna Forest & Garden at 1-800-487-5963.

WARRANTY PERIOD

Any warranted part which is not scheduled for replacement as required maintenance, or which is scheduled only for regular inspection to the effect of "repair or replace as necessary" shall be warranted for 2 years. Any warranted part which is scheduled for replacement as required maintenance shall be warranted for the period of time up to the first scheduled replacement point for that part.

DIAGNOSIS

The owner shall not be charged for diagnostic labor which leads to the determination that a warranted part is defective, if the diagnostic work is performed at an approved Husqvarna Forest & Garden servicing dealer.

CONSEQUENTIAL DAMAGES

Husqvarna Forest & Garden may be liable for damages to other engine components caused by the failure of a warranted part still under warranty.

WHAT IS NOT COVERED

All failures caused by abuse, neglect or improper maintenance are not covered.

ADD -ON OR MODIFIED PARTS

The use of add-on or modified parts can be grounds for disallowing a warranty claim. Husqvarna Forest & Garden is not liable to cover failures of warranted parts caused by the use of add-on or modified parts.

HOW TO FILE A CLAIM

If you have any questions regarding your warranty rights and responsibilities, you should contact your nearest authorized servicing dealer or call Husqvarna Forest & Garden at 1-800-487-5963.

WHERE TO GET WARRANTY SERVICE

Warranty services or repairs shall be provided at all Husqvarna Forest & Garden authorized servicing dealers.

MAINTENANCE, REPLACEMENT AND REPAIR OF EMISSION-RELATED PARTS

Any Husqvarna Forest & Garden approved replacement part used in the performance of any warranty maintenance or repairs on emission-related parts, will be provided without charge to the owner if the part is under warranty.

EMISSION CONTROL WARRANTY PARTS LIST

1. Carburetor and internal parts
2. Intake pipe, airfilter holder and carburetor bolts.
3. Airfilter and fuelfilter covered up to maintenance schedule.
4. Ignition System
 - a) Spark Plug, covered up to maintenance schedule
 - b) Ignition Module
5. Muffler with catalytic converter

MAINTENANCE STATEMENT

The owner is responsible for the performance of all required maintenance, as defined in the operator's manual.

114 00 24-93



2002W19