

Operator's manual (CARB II, EPA II)

326E_X-SERIES

Please read these instructions carefully and make sure you understand them before using the machine.

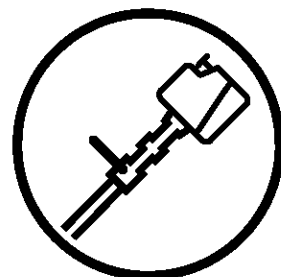

English

EXPLANATION OF SYMBOLS

Symbols



WARNING! The edger can be dangerous!
Careless or incorrect use can result in serious or fatal injury to the operator or others.



Read through the Operator's Manual carefully and understand the content before using the machine.



Always use:

- A protective helmet where there is a risk of falling objects.
- Ear protection
- Approved eye protection



• Max. speed of output axle, rpm



• This product is in accordance with applicable CE directives.



• Beware of thrown objects and ricochets.



• Warning for rotating blade.
Keep hands and feet clear.



• Warning! The blade continues to rotate even after the engine has stopped.

When the engine has stopped, stop the blade from rotating by letting the blade come in contact with the ground.

Indicates the direction of rotation.

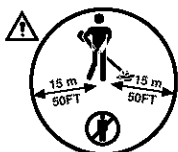

• The operator of the machine must ensure that no persons or animals comes within a 15 metre radius while working.

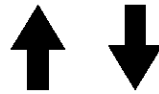

• Arrows which show limits for handle mounting.



• Always wear approved protective gloves.



• Use anti-slip and stable boots.

Other symbols/decals on the machine refer to special certification requirements for certain markets.

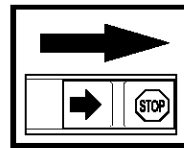

Checks and/or maintenance should be carried out with the engine switched off, with the stop switch in the STOP position.

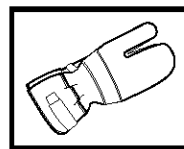

Always wear approved protective gloves.

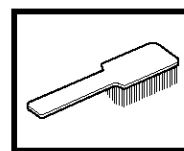

Regular cleaning required.

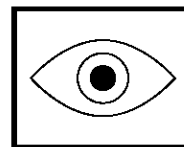

Ocular control.

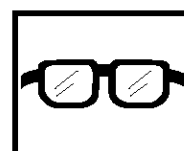

Approved eye protection must always be used.

CONTENTS

Husqvarna AB has a policy of continuous product development and therefore reserves the right to modify the design and appearance of products without prior notice.

Maintenance, replacement, or repair of the emission control devices and systems may be performed by any nonroad engine repair establishment or individual.



WARNING!
Under no circumstances may the design of the machine be modified without the permission of the manufacturer. Always use genuine accessories. Non-authorized modifications and/or accessories can result in serious personal injury or the death of the operator or others.

Your warranty does not cover damage or liability caused by the use of non-authorized accessories or replacement parts.



WARNING!
The inside of the muffler with catalytic converter contains chemicals that may cause cancer. Do not contact inside of damaged muffler.

IMPORTANT ENGINE INFORMATION

 **Husqvarna**

HUSQVARNA AB HUSKVARNA SWEDEN TWG
THIS ENGINE CONFORMS TO U.S. EPA PH2 AND 2000-2003
CALIFORNIA EMISSION REGULATIONS FOR SMALL OFF-
ROAD ENGINES. REFER TO OPERATOR'S MANUAL FOR
MAINTENANCE SPECIFICATIONS AND ADJUSTMENTS.
THE AIR INDEX OF THIS ENGINE IS 3

0	2	3	4	6	8	10
---	---	---	---	---	---	----

THE LOWER THE AIR INDEX, THE LESS POLLUTION
EMISSIONS COMPLIANCE PERIOD: CATEGORY 

This engine label certifies that the product has been approved in accordance with American exhaust emissions requirements EPA Ph II and CARB Tier II.

The Emissions Compliance Period referred to on the Emissions Compliance label indicates the number of operating hours for which the engine has been shown to meet Federal and California emission requirements.

Category C=50 hours, B=125 hours, and A=300 hours.



WARNING

The engine exhaust from this product contains chemicals known to the State of California to cause cancer, birth defects or other reproductive harm.

For customer assistance call: 704-921-7000 or contact us at our website: www.husqvarna.com

List of contents

SYMBOL EXPLANATION

Symbols 2

CONTENTS

List of contents 3

SAFETY INSTRUCTIONS

Personal protective equipment 4

The machine's safety equipment 4

Control, maintenance and service of the machine's safety equipment 6

Cutting equipment 7

General safety instructions 8

General working instructions 10

Basic working techniques 10

WHAT IS WHAT?

What is what on the edger? 12

ASSEMBLY

Assembling the loop handlebar 13

Assembling the angle gear 13

Assembling the blade 13

FUEL HANDLING

Fuel mixture 14

Fuelling 14

START AND STOP

Control before starting 15

Start and stop 15

MAINTENANCE

Carburetor 16

Muffler with catalytic converter 18

Cooling system 18

Spark plug 18

Air filter 19

Angle gear 19

Lubricating the flexible drive axle 19

Adjusting the edger's cutting depth 19

Maintenance schedule 20

TECHNICAL DATA

326E_X-SERIES 21

EMISSION CONTROL WARRANTY

STATEMENT

Your warranty rights and obligations 22

SAFETY INSTRUCTIONS

Personal protective equipment

IMPORTANT INFORMATION

- An edger used incorrectly or carelessly can become a dangerous tool, that can cause serious or fatal injury to the operator or others. It is extremely important that you read and understand the content of this manual.
- When using an edger, personal protective equipment approved by the appropriate authorities must be used. Personal protective equipment does not eliminate the risk of accidents, however, it can reduce the effects of an injury in the event of an accident. Ask your dealer for help when choosing protective equipment.



WARNING!

Remove your hearing protection as soon as you stop the engine, so that you can hear any noises or warning signals.

GLOVES

Gloves should be worn when necessary, e.g., when assembling cutting equipment.

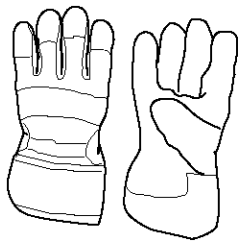

EAR PROTECTION

Ear protection offering sufficient dampening effect should be used.

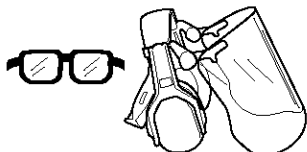

EYE PROTECTION

Blows from branches or objects thrown by the rotating cutting equipment can damage the eyes.



BOOTS

Use anti-slip and stable boots.

CLOTHING

Wear clothes made of a strong fabric and avoid loose clothing that can catch on shrubs and branches. Always wear heavy-duty long pants. Do not wear jewellery, shorts, sandals or go barefoot. Secure hair so it is above shoulder level.

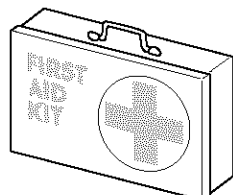

FIRST AID KIT

A first aid kit should be carried by operators of the edger.

The machine's safety equipment

This section describes the machine's safety equipment, its function and how checks and maintenance are carried out to ensure that it operates correctly. (See the chapter "What is what" to locate where this equipment is positioned on your machine.)



WARNING!

Never use a machine with defective safety equipment. Follow the control, maintenance and service instructions described in this section.

1. Throttle trigger lock

The throttle trigger lock is designed to prevent the throttle from accidentally being engaged. When the trigger lock (A) is pressed into the handle (= when you hold the handle) the throttle (B) is released.

When the grip on the handle is released the throttle and the throttle trigger lock return to their original positions. This takes place via two independent return spring systems. This means that the throttle is automatically locked in the "idling" position.

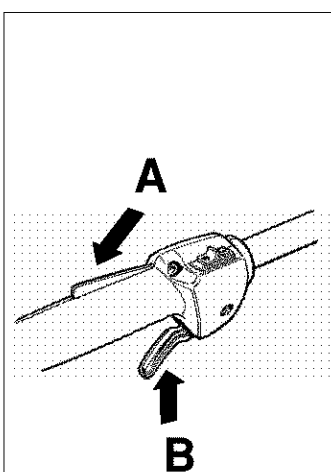

2. Stop switch

The stop switch should be used to stop the engine.

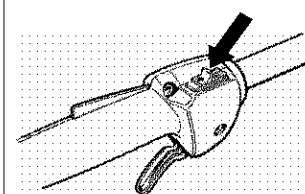

3. Cutting attachment guard

This guard is intended to prevent objects from being thrown towards the operator and to protect the operator from unintentional contact with the cutting attachment.

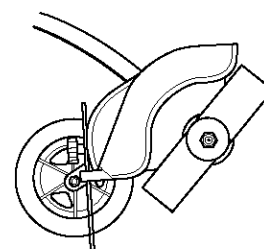

SAFETY INSTRUCTIONS

4. Vibration damping system

Your machine is equipped with a vibration damping system, which is designed to give as vibration-free and comfortable use as possible.

The use of incorrect cutting equipment increases the level of vibration.

The machine's vibration damping system reduces the transfer of vibrations between the engine unit/cutting equipment and the machine's handle unit.

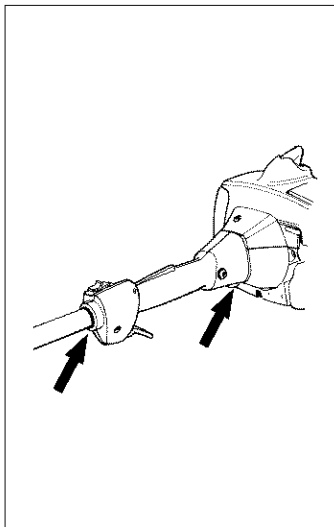

WARNING!

Over exposure to vibrations can result in blood-vessel or nerve injury to persons suffering with blood circulation problems. Seek medical attention if you experience physical symptoms that can be related to over exposure to vibrations. Examples of such symptoms are "numbness", lack of feeling, "tickling", "pricking", "pain", lack of or a reduction in normal strength, changes in the colour of the skin or its surfaces. These symptoms normally appear in the fingers, hands or wrists.

5. Muffler

The muffler is designed to give the lowest possible noise level and to direct the engine's exhaust fumes away from the operator. Mufflers equipped with a catalytic converter are also designed to reduce the hazardous substances in the exhaust fumes.

In countries that have a warm and dry climate the risk of fire is obvious. We have therefore fitted certain mufflers with a spark arrest screen. Make sure that your muffler is fitted with this kind of screen.

It is extremely important that the instructions for checking, maintaining and servicing the muffler are followed. (See the section "Control, maintenance and service of the machine's safety equipment").

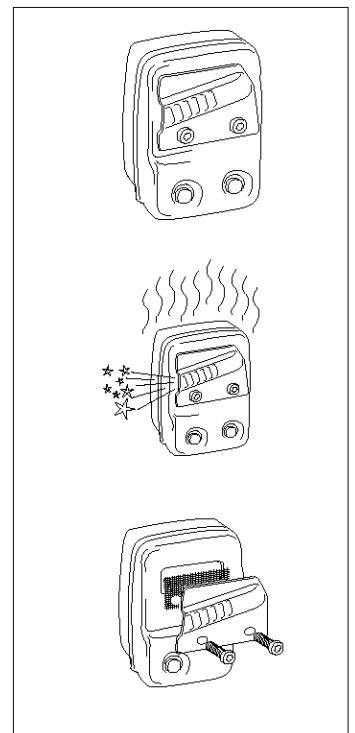

WARNING!

The exhaust fumes from the engine are hot and may contain sparks which can start a fire. Never start the machine indoors or near combustible material!



WARNING!

Mufflers fitted with catalytic converters become extremely hot during use and after stopping. This also applies at idling speeds. Contact can result in burns to the skin. Be observant to the risk of fire!

6. Cutting equipment

The blade is designed and processed to withstand loads that edging of a lawn involves.

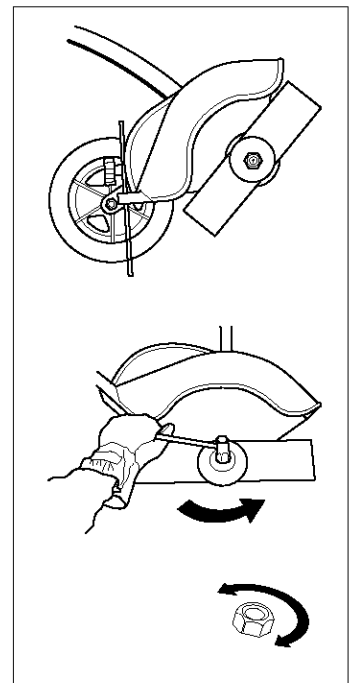

7. Locking nut

The locking nut secures the cutting equipment on the output shaft.

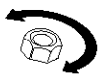

SAFETY INSTRUCTIONS

Control, maintenance and service of the machine's safety equipment

IMPORTANT INFORMATION

- All service and repairs to the machine require special training.
- This applies especially to the machine's safety equipment. If the machine does not meet any of the controls listed below you should contact your service workshop.
- The purchase of one of our products guarantees that professional repair and servicing will be carried out on it. If the point of purchase is not one of our servicing dealers, please ask for details of the closest service workshop.

1. Throttle trigger lock

- Check that the throttle is locked in the "idling position" when the throttle trigger lock is in its original position.
- Press in the throttle trigger lock and make sure it returns to its original position when released.
- Ensure that the throttle and throttle trigger lock move easily and that their return spring systems function.
- See section "Start". Start the machine and apply full throttle. Release the throttle and check that the cutting equipment stops and remains at a standstill. If the cutting equipment rotates with the throttle in the idling position then the carburettor's idling setting must be checked. See chapter "Maintenance".

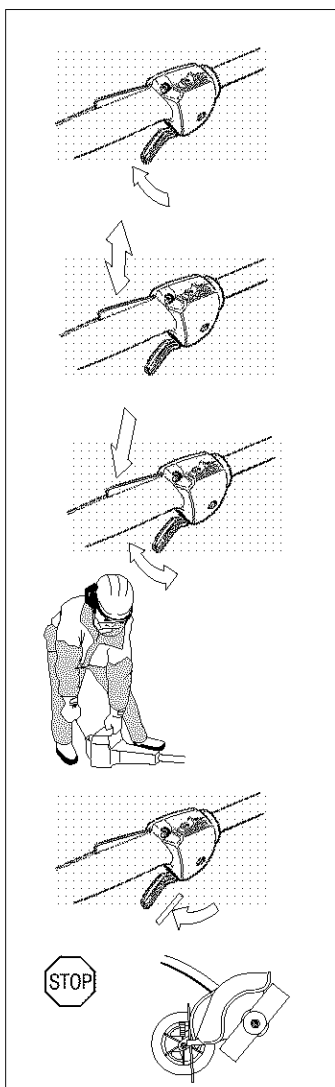

2. Stop switch

- Start the engine and make sure that the engine stops when the stop switch is moved to the stop position.

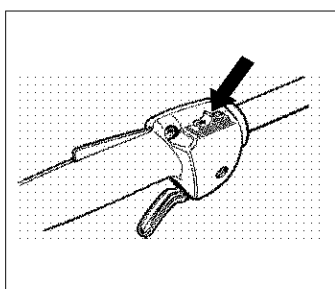

3. Cutting attachment guard

- Ensure that the guard is undamaged and is not cracked.
- Replace the guard if it has been exposed to impact or is cracked.
- Always use the prescribed blade and guard combination, see chapter "Technical data".

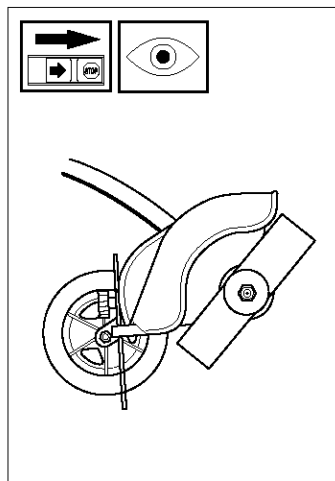

4. Vibration damping system

- Check the vibration damping element regularly for material cracks and distortion.
- Check that the vibration damping element is undamaged and securely attached.

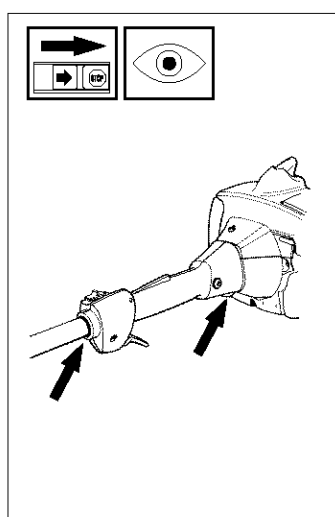

5. Muffler

1. Never use a machine that has a defective muffler.
2. Check regularly that the muffler is secure.
3. If your muffler is fitted with a spark arrest screen then it should be cleaned regularly. A blocked screen leads to the engine overheating with serious damage as a result. Never use a muffler with a defective spark arrest screen.

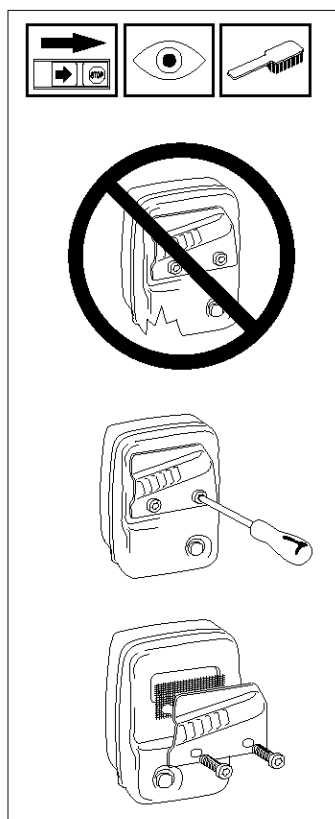

SAFETY INSTRUCTIONS

6. Cutting equipment

The two basic rules:

1. Only use the cutting equipment we recommend! See chapter "Technical data".
2. Check the cutting equipment with regard to damage and crack formation. Damaged cutting equipment should always be replaced.

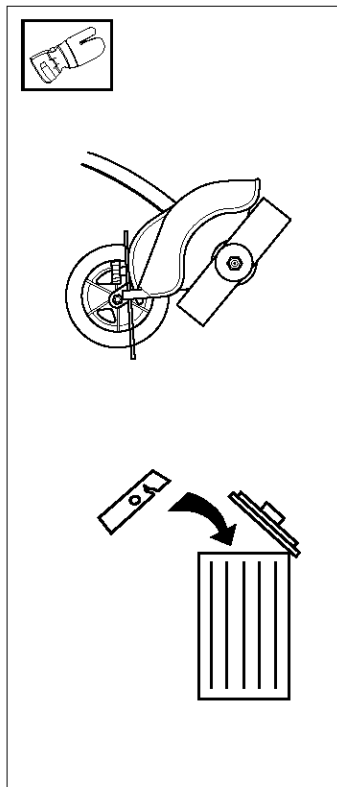

WARNING!
Always stop the engine before starting work on any part of the cutting equipment. This continues to rotate even after the throttle has been released. Ensure that the cutting equipment has stopped completely and remove the cable from the spark plug before you start to work on it.

7. Locking nut

- Protect your hand from injury when assembling, use the blade guard as protection when tightening with a socket spanner. Tighten the nut by turning against the direction of rotation. Loosen the nut by turning in the direction of rotation. (NOTE! the nut has a left-hand thread).
- Tighten the nut using a socket spanner, 35 - 50 Nm (3.5 - 5 kpm).

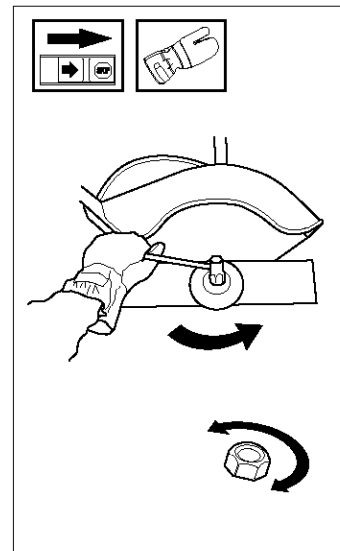

NOTE!

The locking nut's nylon lock must not be so worn that it can be turned by hand. The lock shall hold at least 1.5 Nm. The nut should be replaced after it has been put on approx. 10 times.



WARNING!
Never use a machine with defective safety equipment. The safety equipment should be maintained as described in this section. If your machine does not meet any of these controls you should contact your service workshop.

SAFETY INSTRUCTIONS

General safety instructions

IMPORTANT INFORMATION

- The machine is only designed for cutting the edges of lawns.
- The only accessories to be used with the engine unit as a drive source are the cutting units we recommend in the chapter "Technical data".
- The operator is responsible for accidents and the risk people and property are exposed to.
- Never use the machine if you are tired, if you have consumed alcohol, or if you are taking medicines that can affect your sight, your judgement or the control of your body.
- Do not operate when it's dark.
- Use personal protective equipment. See the section "Personal protective equipment".
- Never use a machine that has been modified so that it no longer corresponds with the original design.
- Never use a machine that is faulty. Follow the maintenance, control and service instructions in this Operator's Manual. Some maintenance and service actions should be carried out by trained and qualified specialists. See the chapter "Maintenance".
- All covers and guards must be fitted before starting the machine. Check that the spark plug cap and HT lead are not damaged, otherwise you could get an electric shock.



WARNING!
Faulty cutting equipment increases the risk of accidents.

Personal protection

- Always wear boots and other equipment described in the section "Personal protective equipment".
- Always wear working clothes and heavy-duty long trousers.
- Never wear loose sitting clothes or jewellery.
- Persons with long hair should, for personal safety, put their hair up.

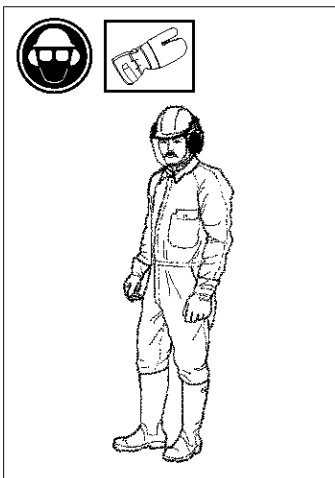

Safety instructions regarding the surroundings

- Never allow children to use the machine.
- Ensure no one comes closer than 15 metres when working.
- Never allow anyone else to use the machine without first ensuring that they have understood the contents of the Operator's Manual.

Safety instructions before starting work

- Inspect the working area. Remove any objects, such as stones, broken glass, nails, steel wire, string, etc. that can be thrown or can wrap around the blade or blade guard.
- Keep others at a safe distance. Children, animals, onlookers and helpers should stand outside of the safety zone of 15 m (50 feet). Stop the machine immediately if any one should approach.
- Check the entire machine before starting work. Replace damaged parts. Check for fuel leakage and that all safety guards and covers are complete and fastened securely. Check all nuts and bolts.



- Check the blade for cracks or any other damage.
- Ensure the blade guard is mounted and not damaged.

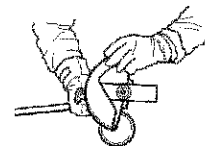
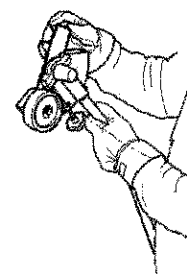

- Check that the blade and blade guard are correctly secured.
- When adjusting the carburettor make sure the blade is held against the ground and that no one is in the immediate vicinity.
- Make sure the blade does not rotate when idling.
- Make sure the handle and safety features are in order. Never use a machine that has parts missing or has been changed in relation to the specification.
- Only use the machine for the purpose it was intended for.

SAFETY INSTRUCTIONS

Start



WARNING!
When the engine starts with the choke lever in the choke or starter throttle position the cutting tool (blade or trimmer) starts to rotate immediately.

- The complete clutch cover with shaft must be fitted before the machine is started, otherwise the clutch can become loose and cause personal injury.
- Never start the machine indoors. Bear in mind the dangers of inhaling the engine's exhaust fumes.
- Observe your surroundings and make sure that there is no risk of people or animals coming into contact with the cutting equipment.
- Place the machine on the ground, make sure the blade is free from branches and stones. Press the machine body against the ground using your left hand (NOTE! Do not use your foot). Grip the starter handle with your right hand and pull the starter cord.

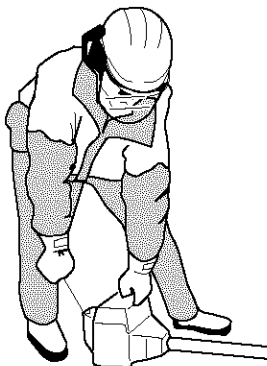

Fuel safety

- Always use a fuel container with an anti-spill valve.
- Never fill the machine while the engine is running. Stop the engine and allow it to cool for a few minutes before refuelling.
- Provide good ventilation when filling or mixing fuel (petrol and 2-stroke oil).
- Move the machine at least 3 m from the filling position before starting.
- Never start the machine:
 - a) If you have spilt fuel on it. Wipe up all spillage.
 - b) If you have spilt fuel on yourself or your clothes. Change your clothes.
 - c) If there is a fuel leak. Make regular checks for leakage from the fuel cap and the fuel supply pipes.

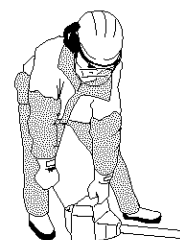
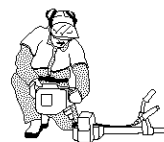

Transport and storage

- Store and transport the machine and fuel so that any leakage or fumes do not risk coming into contact with sparks or naked flames. For example, electric machines, electric motors, electrical switches/power switches, heaters or the like.
- When storing or transporting fuel, approved containers intended for this purpose must be used.
- When storing the machine for long periods the fuel tank must be emptied. Contact your local petrol station to find out how to dispose of excess fuel.
- The engine must be cooling off before storage or packaging.



WARNING!
Exercise great care when handling fuel. Bear in mind the risk of fire, explosions and inhaling fumes.

SAFETY INSTRUCTIONS

General working instructions

IMPORTANT INFORMATION

- This section takes up the basic safety precautions for working with the edger.
- If you encounter a situation where you are uncertain how to proceed you should ask an expert. Contact your dealer or your service workshop.
- Avoid all usage which you consider to be beyond your capability.

Basic safety precautions

1. Observe your surroundings:
 - To ensure that people, animals or other things cannot affect your control of the machine.
 - To ensure that the above mentioned do not come into contact with the cutting equipment or objects that can be thrown by the cutting equipment.
 - **NOTE!** Never use a machine without the possibility of calling for help in the event of an accident.

2. Avoid usage in unfavourable weather conditions. For example, thick fog, heavy rain, strong winds or extreme cold, etc. To work in bad weather conditions is tiring and can create dangerous circumstances, e.g. slippery surfaces.
3. Make sure you can walk and stand safely. Look out for any obstacles with unexpected movement (roots, stones, branches, pits, ditches, etc.). Take great care when working on sloping ground.



4. The engine should be switched off before moving.
5. Never put the machine down with the engine running unless you have good sight of it.

Basic working techniques

Safety instructions while working

- Always ensure you have a safe and firm foothold.
- Always hold the machine with both hands. Hold the machine of the right-hand side your the body.
- Make sure your hands and feet do not come into contact with the blade when the engine is running.
- When the engine is switched off, keep your hands and feet away from the blade until it has stopped.
- Always cut edges at full throttle.



- Always keep the blade close to the ground.
- Always drop to idling speed after each working operation. Longer periods running at full throttle without loading the engine (that is without resistance, which the engine feels from the cutting equipment when trimming) can lead to serious engine damage.
- Be especially careful when pulling the edger towards you during work.
- If heavy vibrations occur, stop the engine. Remove the spark plug cable from the spark plug. Check that the machine is not damaged. Repair any damage.



WARNING!
Sometimes grass and stones can collect in the blade guard and blade. Always stop the engine when cleaning.



WARNING!
Beware of thrown objects. Always wear eye protection. Never lean over the blade guard. Stones rubbish etc. can be thrown up into the eyes resulting in blindness or other serious injury.
Keep unauthorised persons at a distance. Children, animals, onlookers and helpers should be outside the safety zone of 15 meters (50 feet). Stop the machine immediately if anyone approaches.
The bevel gear unit can get hot during use and may remain so for a while afterwards. There is a risk of slight burns if you touch it.

SAFETY INSTRUCTIONS

Safety instructions after completing work

- Ensure the blade has stopped before cleaning, carrying out repairs or an inspection. Remove the spark plug cable from the spark plug.
- Wear heavy-duty gloves when carrying out repairs on the edger.
- Store the machine out of reach of children.
- Only use original spare parts with repair.

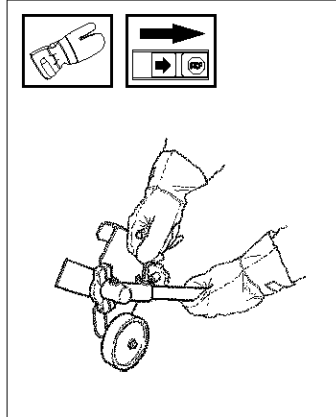

WHAT IS WHAT?

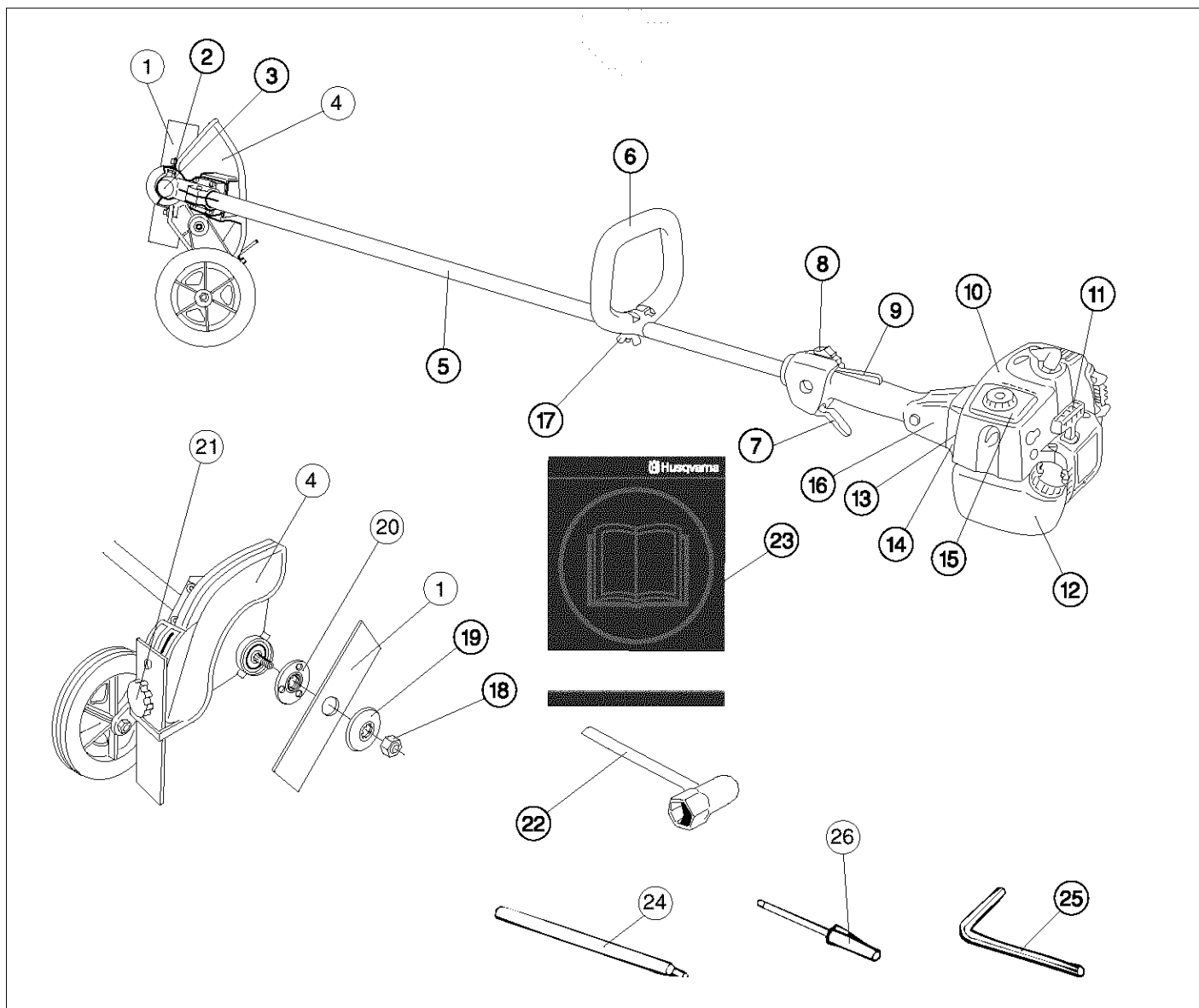

What is what on the edger?

- | | |
|--------------------------|----------------------------|
| 1. Blade | 15. Air filter cover |
| 2. Grease filler cap | 16. Clutch cover |
| 3. Angle gear | 17. Handlebar adjustment |
| 4. Blade guard | 18. Locking nut |
| 5. Shaft | 19. Support flange |
| 6. Loop handlebar | 20. Drive disc |
| 7. Throttle | 21. Locking handle |
| 8. Stop switch | 22. Socket spanner |
| 9. Throttle trigger lock | 23. Operator's Manual |
| 10. Cylinder cover | 24. Locking pin |
| 11. Starter handle | 25. Allen key |
| 12. Fuel tank | 26. Carburetor screwdriver |
| 13. Choke | |
| 14. Air purge | |

ASSEMBLY

Assembling the loop handlebar

- Position the handle on the shaft. Note that the handle must be mounted below the arrow on the shaft.
- Fit the bolt, securing plate and wing nut as shown in the diagram.
- Tighten the wing nut.

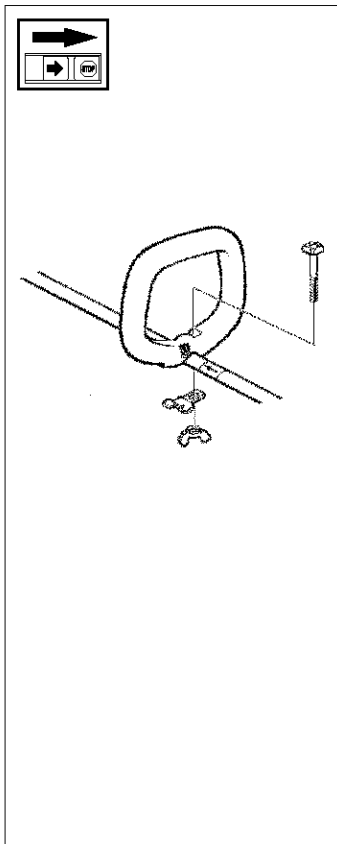

Assembling the blade

Fit the blade as follows:

1. Fit the drive disc (A) on the outgoing shaft. Make sure that the edge that fits in the hole of the blade is facing outward.
2. Block the blade rotation by inserting locking pin in the hole behind the blade guard engaging it in the corresponding hole in the drive disc.
3. Fit the blade (B) on the drive disc.
4. Fit the support flange (C). The support flange must be fitted with its outer edge hard up against the blade.
5. Fit the locknut (D). NOTE! The locknut has left-hand threads. The tightening torque of the locknut is 35 – 50 Nm.
6. Remove the locking pin.

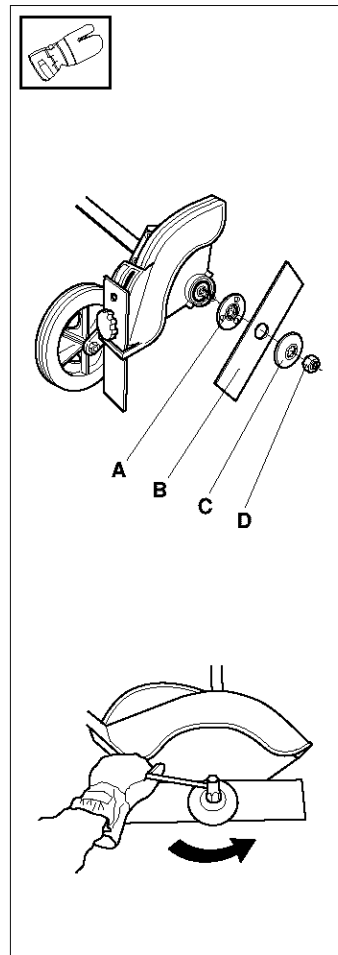

Assembling the angle gear

- Assemble the angle gear back on the supporting tube. Turn the blade so that the drive shaft engages in the angle gear.
- Position the angle gear so that its slot is aligned with the line on the supporting tube.
- Firmly tighten the screw.

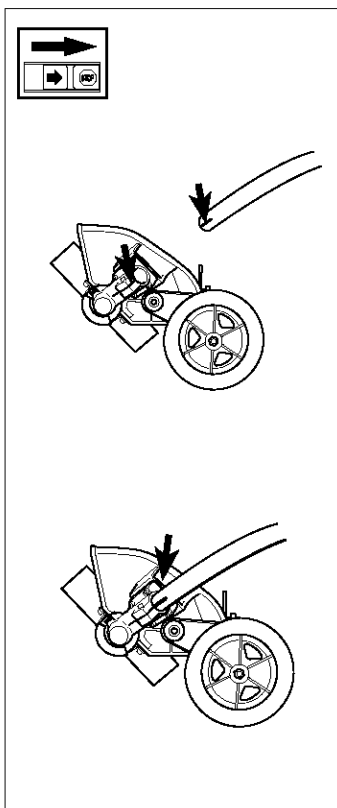

NOTE! Do not forget to remove the locking pin before using the machine.

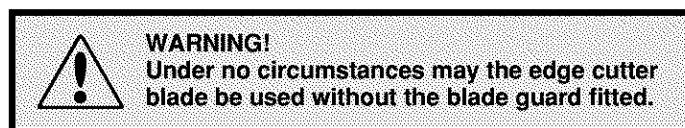

FUEL HANDLING

Fuel mixture

NOTE!

The edger is fitted with two-stroke engines and must always be run on a mixture of gasoline and two-stroke oil. To ensure the correct mixture proportions it is important to measure the quantity of oil accurately. When mixing small amounts of fuel small discrepancies in the amount of oil has a great bearing on the proportions of the fuel mixture.



WARNING!
Always provide good ventilation when handling fuel.

Gasoline

NOTE!

Always use high grade unleaded oil mixed gasoline (minimum 87 RON). Leaded fuel will destroy the catalytic converter and it will no longer serve its purpose.

- This engine is certified to operate on unleaded gasoline.
- The lowest recommended octane rating is 87. If you run the engine on lower octane rating than 87 so-called "knocking" can occur. This leads to an increased engine temperature, which can result in a serious engine breakdown.
- When working at continuous high revs a higher octane rating is recommended.

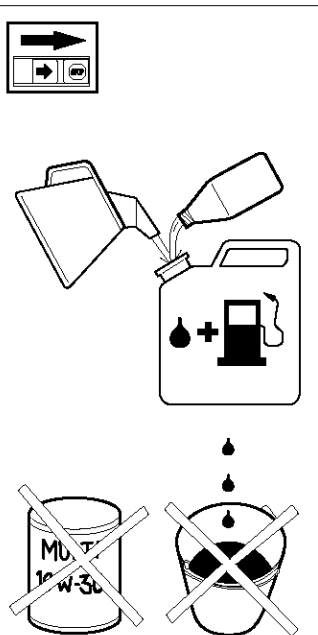

Two-stroke oil

- For the best results use HUSQVARNA two-stroke oil, which has been specially developed for two-stroke engines. Mixing ratio 1:50 (2%).
- Never use two-stroke oil intended for water cooled outboard motors, so-called outboard motor oil.
- Never use oil intended of four-stroke engines.

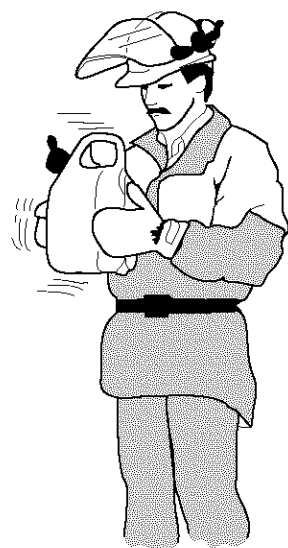

Mixture

- Always mix gasoline and oil in a clean container intended for fuel.
- Always start by filling half the quantity of gasoline required. Then add the entire oil quantity. Mix (shake) the fuel mixture. Fill the remaining quantity of gasoline.
- Mix (shake) the fuel mixture carefully before filling in the machine's fuel tank.
- Do not mix more than max. one month's supply of fuel.
- If the clearing saw is not used for a long period of time, the fuel tank should be emptied and cleaned.
- This engine is certified to operate on unleaded gasoline.



WARNING!
The catalytic converter muffler gets very hot during and after use. This also applies during idling. Be aware of the fire hazard, especially when handling the saw near flammable substances or vapours.

Fuelling



WARNING!
The following precautions reduce the risk of fire:
Do not smoke or place any sources of heat in the vicinity of the fuel. Never refuel when the engine is running. Always stop the engine and let it cool for a few minutes before refuelling. Open the fuel cap slowly when fuelling so that any over pressure is released slowly. Tighten the fuel cap carefully after refuelling. Always move the machine from the fuelling place before starting.

- Clean around the fuel cap. Contamination in the tank can disrupt operations.
- Ensure that the fuel is well mixed by shaking the container before filling the tank.

Gasoline	Oil 2%(1:50)
Lit.	Lit.
5	0,10
10	0,20
15	0,30
20	0,40
US gallon	US fl. oz.
1	2 1/2
2 1/2	6 1/2
5	12 7/8

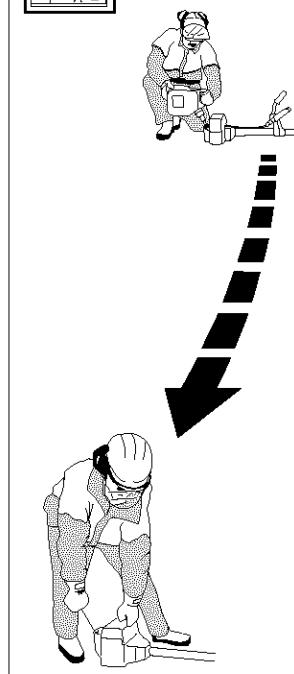

START AND STOP

Control before starting

For reasons of safety follow these recommendations!

- Check that the support flange is not cracked due to fatigue or due to being tightened too much. Replace the support flange if it is cracked.
- Ensure that the nut has not lost its tightening capacity
The nut lock shall have a locking torque of at least 1.5Nm. The nut's tightening torque shall be 35-50 Nm.
- Check that the blade and the blade guard are not damaged or cracked. Replace the blade or blade guard if it has been exposed to impact or if it is cracked.

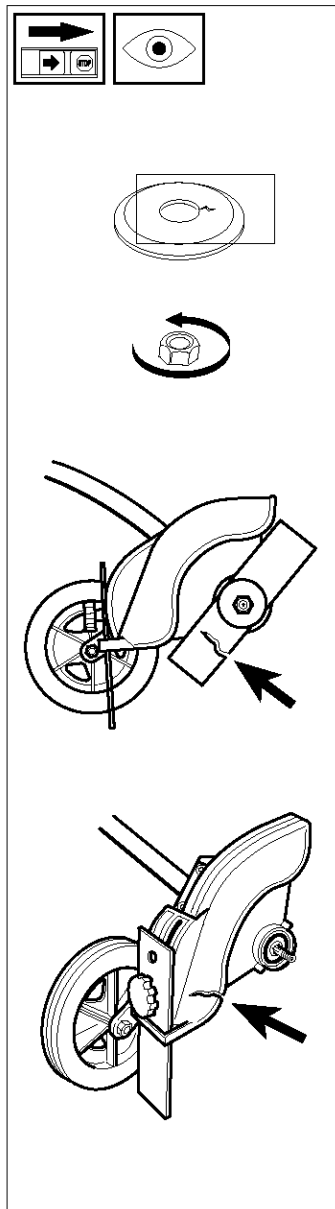

Start and stop



WARNING!
The complete clutch cover with shaft must be fitted before the machine is started, otherwise the clutch can become loose and cause personal injury.

Always move the machine from the filling position before starting. Place the machine on a flat surface. Make sure the blade cannot come into contact with any object. Make sure that no unauthorised persons are in the working area, otherwise there is a risk of serious personal injury. The safety distance is 15 metres.

Cold engine

IGNITION:
Set the stop switch to the start position.

CHOKE:
Set the choke control in the choke position.

AIR PURGE:
Press the air purge diaphragm repeatedly until fuel begins to fill the diaphragm. The diaphragm need not be completely filled.

Warm engine

Use the same starting procedure as for the cold engine, but do not set the choke control in the choke position. The start throttle position is obtained by setting the choke control in the choke position and then returning it to its original position.

Stop

The engine is stopped by switching off the ignition.

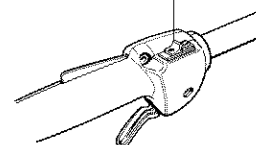
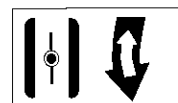
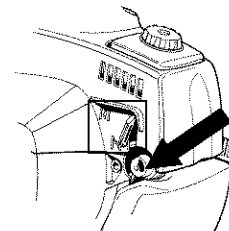
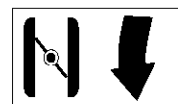

WARNING!
When the engine starts with the choke lever in the choke or starter throttle position the cutting tool (blade or trimmer) starts to rotate immediately.

Start

Press the machine body against the ground using your left hand (NOTE! Not your foot). Grip the starter handle, slowly pull out the cord with your right hand until you feel some resistance (the starter pawls grip), now quickly and powerfully pull the cord. Reset the choke control as soon as the engine fires and repeat until the engine starts. When the engine starts quickly apply full throttle and the start throttle will automatically disengage.

NOTE! Do not pull the starter cord out completely and do not release the starter cord from the fully extended position. This can damage the machine.

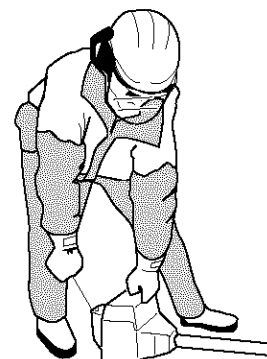

MAINTENANCE

Carburetor

Your Husqvarna product has been designed and manufactured to specifications that reduce harmful emissions.

After your unit has been run 8-10 tanks of fuel the engine has broken in. To ensure that your unit is at peak performance and producing the least amount of harmful emissions after break in, have your authorized servicing dealer, who has a revolution counter at his disposal, to adjust your carburetor for optimum operating conditions.



WARNING!
The complete clutch cover with shaft must be fitted before the machine is started, otherwise the clutch can become loose and cause personal injury.

Operation

- The carburetor governs the engine's speed via the throttle. Air/fuel is mixed in the carburetor. The air/fuel mixture is adjustable. To take advantage of the engine's optimal output the adjustment must be correct.

- The setting of the carburetor means that the engine is adapted to local conditions, for example, the climate, altitude, gasoline and the type of 2-stroke oil.

- The carburetor is equipped with three adjustment possibilities:

L = Low speed needle
H = High speed needle
T = Idle speed adjuster screw

- The fuel quantity in relation to the air flow permitted by the throttle opening is adjusted using the L and H-needles. Turning the needles clockwise gives a leaner fuel mixture (less fuel) and turning them anti-clockwise gives a richer fuel mixture (more fuel). A leaner mixture gives high revs while a richer mixture give less revs.

- The T-screw regulates the position of the throttle while the engine is idling. Turning the screw clockwise gives a higher idling speed while turning it anti-clockwise gives a lower idling speed.

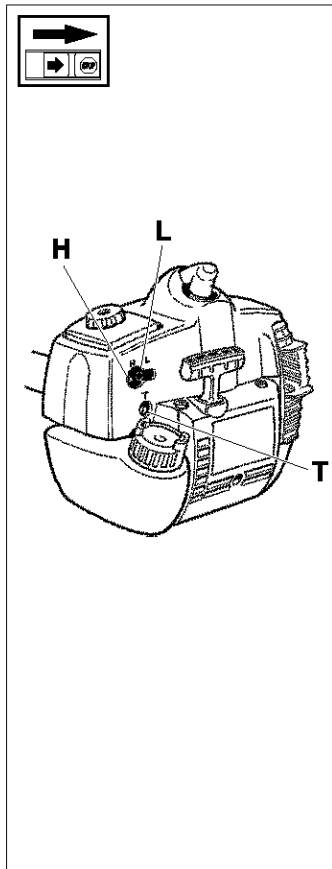

Basic setting

- The carburetor is set to its basic setting when test run at the factory. The basic setting should be kept during the machine's first working hours. Thereafter the carburetor should be finely adjusted. Fine adjustment should be carried out by a skilled technician.

NOTE! If the cutting attachment rotates/moves while the engine is idling the T-screw should be turned anti-clockwise until the cutting attachment stops.

Rec. idling speed: 2700 rpm.

Recommended max. speed: See "Technical data".



WARNING!
If the idling speed cannot be adjusted so that the cutting attachment stops, contact your service workshop. Do not use the machine until it has been correctly adjusted or repaired.

Fine adjustment

- When the machine has been "run-in" the carburetor should be finely adjusted. **The fine adjustment should be carried out by qualified person.** First adjust the L-jet, then the idling screw T and then the H-jet.

Conditions

- Before any adjustments are made the airfilter should be clean and the airfilter cover fitted. Adjusting the carburetor while a dirty airfilter is in use will result in a leaner mixture when the filter is finally cleaned. This can give rise to serious engine damage.
- Carefully turn the L and H needle to the mid point between fully turned in and fully turned out.
- **Do not attempt to adjust the needles beyond the stops as damage can occur.**
- Now start the machine according to the starting instructions and run it warm for 10 minutes.

NOTE! If the cutting attachment rotates/moves the T screw should be turned anti-clockwise until the cutting attachment stops.

Low speed needle L

Try to find the highest idling speed, turning the low speed needle L clockwise respectively counter-clockwise. When the highest speed has been found, turn the low speed needle L 1/4 turn counter-clockwise.

NOTE! If the cutting attachment rotates/moves in the idling position, turn the idling speed screw T counter-clockwise until the cutting attachment stops.

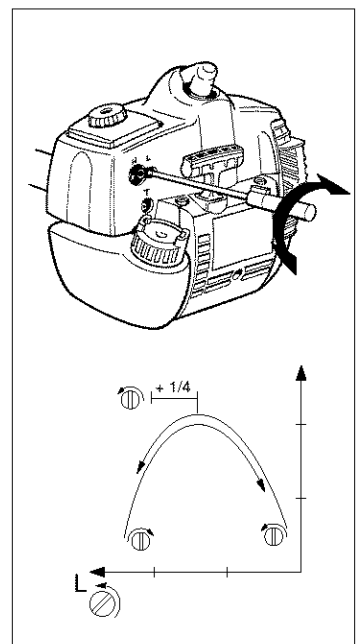

MAINTENANCE

Final setting of the idling speed T

Adjust the idling speed with the screw T, if it is necessary to readjust. First turn the idle speed adjusting screw T clockwise until the cutting attachment starts to rotate/move.

Then turn, counter-clockwise until the cutting attachment stops. A correctly adjusted idle speed setting occurs when the engine runs smoothly in every position. It should also be good margin to the rpm when the cutting attachment starts to rotate/move.

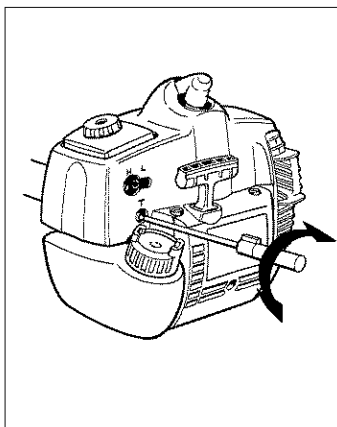

CAUTION! Contact your servicing dealer, if the idle speed setting cannot be adjusted so that the cutting attachment stops. Do not use the machine until it has been properly adjusted or repaired.

High speed needle H

The high speed needle H influences the power, speed, temperature and fuel consumption of the machine. A too lean adjusted high speed needle H (high speed needle H closed too much) gives overrevs and damages the engine. Do not let the machine run at full speed for more than 10 seconds.

Turn the high speed needle very slowly clockwise until engine speed is reduced. Thereafter turn the high speed needle very slowly counter-clockwise and stop when the engine begins to run roughly. Then turn the high speed needle slowly the minimum amount clockwise until the engine runs smoothly.

The high speed needle H is correctly set when the machine "4-cycles" a little. If the machine "whistles" the setting is too lean. If there is too much smoky exhaust gas at the same time as the machine "4-cycles" much, the setting is too rich.

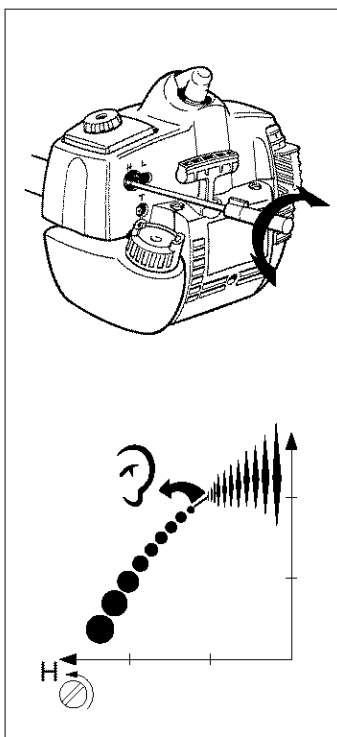

Correctly adjusted carburetor

A correctly adjusted carburetor means that the machine accelerates without hesitation and the machine 4-cycles a little at max speed. Furthermore, the cutting attachment must not rotate/move at idling. A too lean adjusted low speed needle L may cause starting difficulties and bad acceleration.

A too lean adjusted high speed needle H gives lower power = less capacity, bad acceleration and/or damage to the engine. A too rich adjustment of the two speed needles L and H gives acceleration problems or too low working speed.

NOTE! For optimum setting of the carburetor, contact a qualified servicing dealer who has a revolution counter at his disposal.

MAINTENANCE

Muffler with catalytic converter

A muffler fitted with a catalytic converter reduces the extent of the following substances in the exhaust fumes:

- Hydrocarbons (HC). Some hydrocarbons in gasoline and the exhaust are carcinogenic.
- Nitric oxides (NO). Irritating for the breathing air-ways.
- Aldehydes. The most common formaldehyde, is carcinogenic and causes hypersensitiveness.

NOTE! The level of carbon monoxide is not reduced. This is an odourless and extremely poisonous substance. Therefore avoid exposure without good air circulation.

The muffler is also designed to dampen the noise level and to direct the exhaust fumes away from the user. The exhaust fumes are hot and can contain sparks, which can result in fire if the exhaust fumes are directed towards a dry or inflammable material. Some mufflers are fitted with a special spark arrest screen. If your machine is fitted with this type of muffler then the screen should be cleaned at least once a week. This is done using a wire brush. **If the screen is damaged in any way it should be replaced.** If the screen is blocked this will result in engine overheating and damage to the cylinder and piston.

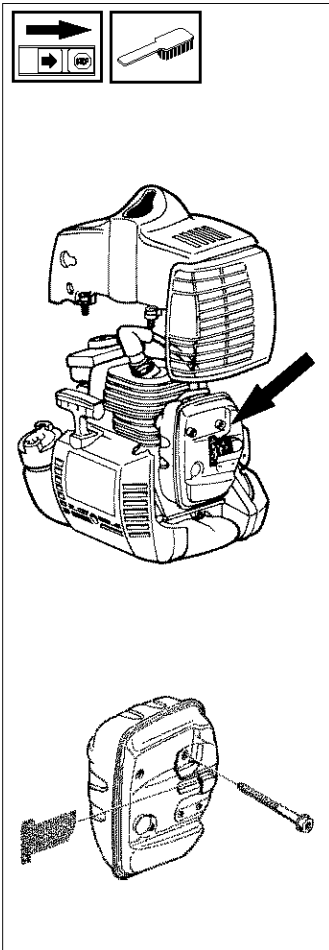

NOTE!

Never use a machine with a defective muffler.

 **WARNING!**
Mufflers fitted with catalytic converters become extremely hot during use and after stopping. This also applies at idling speeds. Contact can result in burns to the skin. Be observant to the risk of fire!

 **WARNING!**
The coating on/in the catalytic element can be hazardous to health if consumed. Wear gloves when carrying out service work on the catalytic converter.

Cooling system

To maintain as low operating temperature as possible the engine is equipped with a cooling system.

The cooling system consists of:

1. An air intake on the starter unit.
2. Cooling fins on the flywheel.
3. Cooling fins on the cylinder
4. Cylinder cover (leads cold air onto the cylinder).

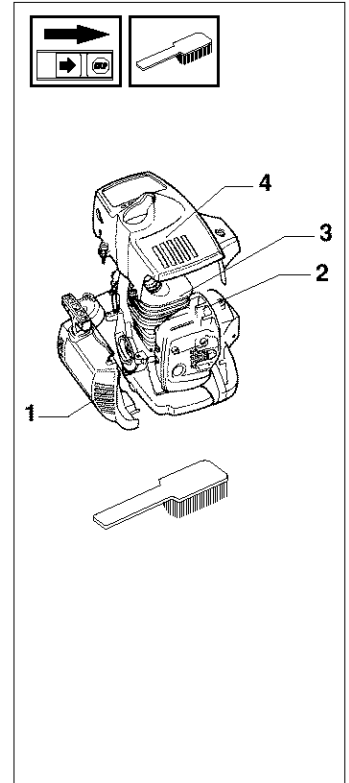

Clean the cooling system using a brush at least once a week, in difficult conditions more often.

A dirty or blocked cooling system leads to the engine overheating resulting in damage to the cylinder and piston.

Spark plug

The condition of the spark plug is affected by:

- An incorrect carburetor setting.
- An incorrect fuel mixture (too much or faulty oil).
- A dirty air filter.

These factors cause deposits on the spark plug electrode that may result in malfunction or starting difficulties.

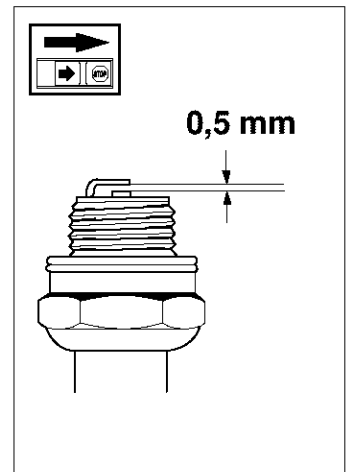

If the machine is low on power, difficult to start or runs poorly while idling always check the spark plug first.

If the spark plug is dirty, clean it and at the same time check that the electrode gap is 0.5 mm. The spark plug should be changed after about one month of operation or earlier if necessary.

NOTE! Always use the recommended type of spark plug. An incorrect spark plug can damage the cylinder/piston.

MAINTENANCE

Air filter

The air filter should be cleaned regularly removing dust and dirt to avoid:

- carburetor malfunction
- starting problems
- reduced engine power
- unnecessary wear to engine parts

Clean the filter after every 25 hours or more regularly if operating conditions are exceptionally dusty.

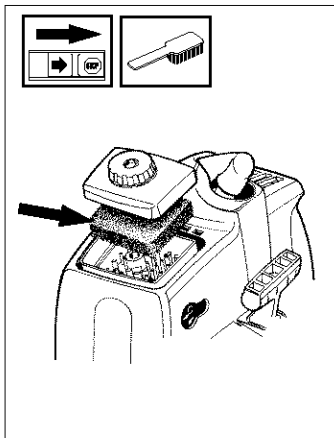

Cleaning the air filter

Dismantle the air filter cover and remove the air filter. Wash in clean, warm soapy water. Ensure that the filter is dry before refitting. An air filter used for a long period of time can never be cleaned completely. Therefore it is necessary to replace the filter from time to time with a new filter. A damaged air filter must always be replaced.

If the machine is used in dusty conditions the air filter should be soaked in oil, see the section on "Oiling the air filter".

Oiling the air filter

Always use HUSQVARNA filter oil, order no. 503 47 73-01. The filter oil contains a solvent to make it spread evenly through the filter. You should therefore avoid skin contact. Put the filter in a plastic bag and pour the filter oil over it. Knead the plastic bag to distribute the oil. Squeeze the excess oil out of the filter inside the plastic bag and pour off the excess before fitting the filter on the machine. Never use common engine oil. This would drain through the filter quite quickly and collect in the bottom.

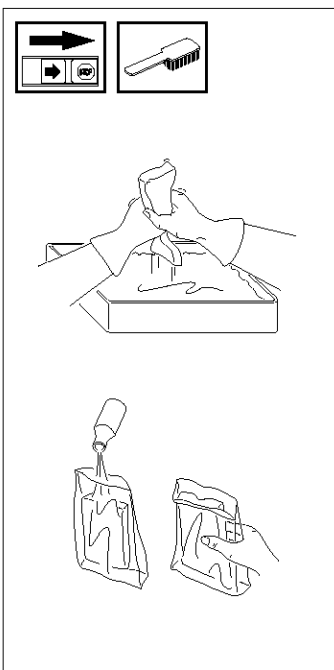

Angle gear

The angle gear is filled with a sufficient quantity of grease at the factory. However, before using the machine you should check that the angle gear is filled to 3/4 with grease. Use HUSQVARNA special grease.

Normally, the grease does not need to be changed except when repairs are carried out.

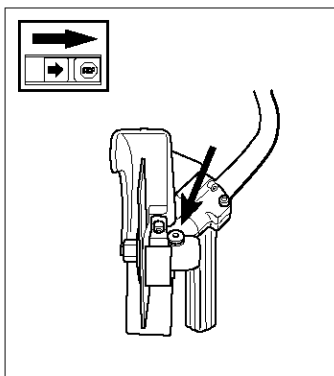

Lubricating the flexible drive axle

Inside the edger's drive shaft is a flexible drive axle. The flexible drive axle should be regularly lubricated after 30 hours of operation. Loosen the two screws on the angle gear and remove it. The flexible drive axle is easily removed from the shaft by taking a firm grip on the axle end. Lubricate the flexible drive axle over its entire length and reinsert it in the shaft. Turn the axle while inserting it so that it correctly engages in the clutch. Replace the angle gear on the drive axle shaft and tighten the two screws.

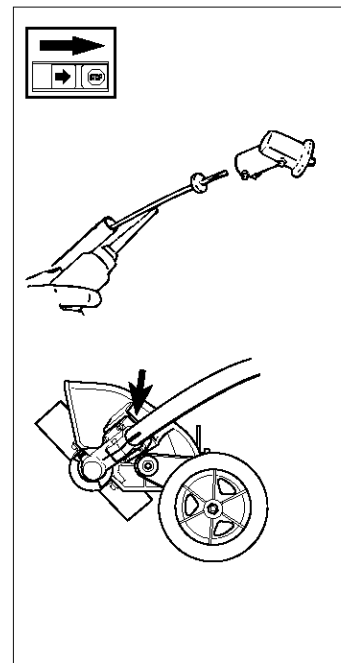

Adjusting the edger's cutting depth

The cutting depth should be adjusted before starting work.

- Loosen the locking handle (A) and rotate the guard by moving the locking handle backwards or forwards. If the locking handle is moved forwards (from the machine) the cutting depth is increased. If the locking handle is moved backwards (towards the machine) the cutting depth is reduced.
- Adjust the cutting depth.
- Lock the locking handle.

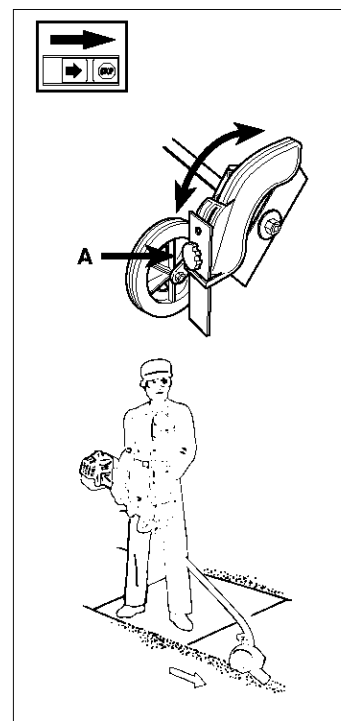

WARNING!

Always bear the machine on the right side of the body. Always wear protective glasses, long trousers and heavy-duty shoes when using the machine. Observe your surroundings, ensure people and animals do not come in the immediate vicinity or can be hit by thrown objects. Apply full throttle before the blade starts to work on the soil.

MAINTENANCE

NOTE: Use only HUSQVARNA replacement parts. Use of other brands of replacement parts can cause damage to your unit or injury to the operator or others. Your warranty does not cover damage or liability caused by the use of accessories and/or attachments not specifically recommended by HUSQVARNA.

Maintenance schedule

Below you will find some general maintenance instructions.

Daily maintenance

- Check throttle trigger and throttle trigger lockout function.
- Check stop switch function.
- Check that blade does not rotate at idling.
- Clean the exterior of the machine.
- Check the guard for damage or cracks.
- Change the guard in case of impacts or cracks.
- Check the blade for cracks and chips or damage. Replace if necessary.
- A non-balanced blade induces heavy vibrations that may damage the machine.
- Check that the locking nut is sufficiently tightened.
- Check that nuts and screws are sufficiently tightened.

Weekly maintenance

- Check the starter, especially cord and return spring.
- Clean the carburetor area.
- Clean the exterior of the spark plug.
- Remove it and check the electrode gap.
- Adjust it to 0,5 mm (.020"), or change the spark plug.
- Clean the cooling fins on the cylinder and check that the air intake at the starter is not clogged.
- Check that the angle gear is filled with grease up to 3/4. Use special grease.
- Clean the air filter.
- Clean the spark arrester screen at muffler. Replace if damaged.
- The flexible drive shaft must be lubricated after every 30 hours in operation or more often.

Monthly maintenance

- Rinse the fuel tank with gasoline.
- Clean the exterior of the carburetor and the space around it.
- Clean the fan and the space around it.
- Check fuel hose for cracks or other damage. Change if necessary.
- Change fuel filter in fuel tank.
- Check clutch, clutch spring and clutch drum for wear. Change if necessary.
- Check electrical wires and connections.
- Change the spark plug.
- Change the airfilter.

TECHNICAL DATA

Technical data

326E_{X-SERIES}

Engine

Displacement, cu. in/cm ³	1,50/24,5
Cylinder bore, inch/mm	1,34/34
Stroke length, inch/mm	1,06/27
Recommended max. speed, rpm	11 000 - 11 700
Idling speed, rpm	2 700
Speed of output shaft, rpm	8 300
Max. engine output, acc. to ISO 8893	0,9 kW/ 8 400 rpm
Catalytic converter muffler	Yes
Speed-regulated ignition system	Yes

Ignition system

Manufacturer/type of ignition system	Walbro MB
Spark plug	Champion RCJ 6Y
Electrode gap, inch/mm	0,02/0,5

Fuel lubrication system

Manufacturer/type of carburetor	Zama C1Q
Fuel tank capacity, US pint/litres	1,06/0,5

Weight

Weight without fuel and cutting tool, Lbs/kg	11,9/5,4
----------------------------------------------	----------

Sound levels

(see note 1)

Equivalent sound pressure levels at the user's ear, measured according to EN ISO 11806 and ISO 11789, dB(A)	94
-------------------------------------------------------------------------------------------------------------	----

Vibration levels

Vibration levels on the handles measured according to EN ISO 11806 and ISO 11789, m/s²

When idling, rear/front handles:	2,0/4,0
At max. speed, rear/front handles:	5,9/7,3

Cutting equipment

Blade	531 00 40-44
Blade guard	503 84 65-01

Note 1: Equivalent sound level is calculated as the time-weighted energy total for sound levels under various working conditions with the following time distribution: 1/2 idle and 1/2 max speed.

EMISSION CONTROL WARRANTY STATEMENT

YOUR WARRANTY RIGHTS AND OBLIGATIONS

The EPA (U.S. Environmental Protection Agency), CARB (California Air Resources Board), Environment Canada and Husqvarna Forest & Garden are pleased to explain the emissions control system warranty on your 2001 and later small off-road engine. In U.S. and Canada, new small off-road engines must be designed, built and equipped to meet the federal and California stringent anti-smog standards. Husqvarna Forest & Garden must warrant the emission control system on your small off-road engine for the periods of time listed below provided there has been no abuse, neglect or improper maintenance of your small off-road engine.

Your emission control system includes Parts such as the carburetor and catalytic convertor the ignition system.

Where a warrantable condition exists, Husqvarna Forest & Garden will repair your small off-road engine at no cost to you including diagnosis, parts and labor.

MANUFACTURER'S WARRANTY COVERAGE

The 2001 and later small off-road engines are warranted for two years. If any emission related part on your engine is defective, the part will be repaired or replaced by Husqvarna Forest & Garden.

OWNER'S WARRANTY RESPONSIBILITIES

As the small off-road engine owner, you are responsible for the performance of the required maintenance listed in your Owner's Manual. Husqvarna Forest & Garden recommends that you retain all receipts covering maintenance on your small off-road engine, but Husqvarna Forest & Garden cannot deny warranty solely for the lack of receipts or for your failure to ensure the performance of all scheduled maintenance.

As the small off-road engine owner, you should, however, be aware that Husqvarna Forest & Garden may deny you warranty coverage if your small off-road engine or a part has failed due to abuse, neglect, improper maintenance or unapproved modifications

You are responsible for presenting your small off-road engine to a Husqvarna Forest & Garden authorized servicing dealer as soon as a problem exists. The warranty repairs should be completed in a reasonable amount of time, not to exceed 30 days.

If you have any questions regarding your warranty rights and responsibilities, you should contact your nearest authorized servicing dealer or call Husqvarna Forest & Garden at 1-800-487-5963.

WARRANTY COMMENCEMENT DATE

The warranty period begins on the date small off-road engine is delivered.

LENGTH OF COVERAGE

Husqvarna Forest & Garden warrants to the initial owner and each subsequent purchaser that the engine is free from defects in materials and workmanship which cause the failure of a warranted part for a period of two years.

WHAT IS COVERED

REPAIR OR REPLACEMENT OF PARTS

Repair or replacement of any warranted part will be performed at no charge to the owner at an approved Husqvarna Forest & Garden servicing dealer.

If you have any questions regarding your warranty rights and responsibilities, you should contact your nearest authorized servicing dealer or call Husqvarna Forest & Garden at 1-800-487-5963.

WARRANTY PERIOD

Any warranted part which is not scheduled for replacement as required maintenance, or which is scheduled only for regular inspection to the effect of "repair or replace as necessary" shall be warranted for 2 years. Any warranted part which is scheduled for replacement as required maintenance shall be warranted for the period of time up to the first scheduled replacement point for that part.

DIAGNOSIS

The owner shall not be charged for diagnostic labor which leads to the determination that a warranted part is defective, if the diagnostic work is performed at an approved Husqvarna Forest & Garden servicing dealer.

CONSEQUENTIAL DAMAGES

Husqvarna Forest & Garden may be liable for damages to other engine components caused by the failure of a warranted part still under warranty.

WHAT IS NOT COVERED

All failures caused by abuse, neglect or improper maintenance are not covered.

ADD -ON OR MODIFIED PARTS

The use of add-on or modified parts can be grounds for disallowing a warranty claim. Husqvarna Forest & Garden is not liable to cover failures of warranted parts caused by the use of add-on or modified parts.

HOW TO FILE A CLAIM

If you have any questions regarding your warranty rights and responsibilities, you should contact your nearest authorized servicing dealer or call Husqvarna Forest & Garden at 1-800-487-5963.

WHERE TO GET WARRANTY SERVICE

Warranty services or repairs shall be provided at all Husqvarna Forest & Garden authorized servicing dealers.

MAINTENANCE, REPLACEMENT AND REPAIR OF EMISSION-RELATED PARTS

Any Husqvarna Forest & Garden approved replacement part used in the performance of any warranty maintenance or repairs on emission-related parts, will be provided without charge to the owner if the part is under warranty.

EMISSION CONTROL WARRANTY PARTS LIST

1. Carburetor and internal parts
2. Intake pipe, airfilter holder and carburetor bolts.
3. Airfilter and fuelfilter covered up to maintenance schedule.
4. Ignition System
 - a) Spark Plug, covered up to maintenance schedule
 - b) Ignition Module
5. Muffler with catalytic converter

MAINTENANCE STATEMENT

The owner is responsible for the performance of all required maintenance, as defined in the operator's manual.



NOTES

114 00 67-93



2002W11