

Cub Cadet

OPERATOR'S MANUAL

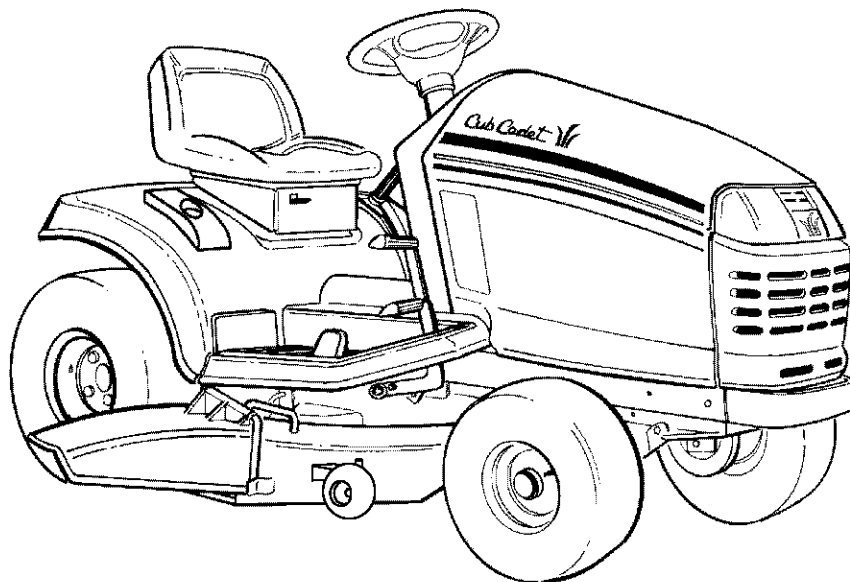

SERIES 2000 TRACTOR Model Number LT 2180

IMPORTANT: READ SAFETY RULES AND INSTRUCTIONS CAREFULLY

Warning: This unit is equipped with an internal combustion engine and should not be used on or near any unimproved forest-covered, brush-covered or grass-covered land unless the engine's exhaust system is equipped with a spark arrester meeting applicable local or state laws (if any). If a spark arrester is used, it should be maintained in effective working order by the operator. In the State of California the above is required by law (Section 4442 of the California Public Resources Code). Other states may have similar laws. Federal laws apply on federal lands. A spark arrester for the muffler is available through your nearest engine authorized service dealer or contact the service department, P.O. Box 361131 Cleveland, Ohio 44136-0019.

CUB CADET LLC P.O. BOX 361131 CLEVELAND, OHIO 44136-0019 [www.cubcadet.com]

**Briggs & Stratton Corporation (B&S), the California Air Resources Board (CARB)
and the United States Environmental Protection Agency (U.S. EPA)
Emission Control Systems Warranty Statement(Owner's Defect Warranty Rights and Obligations)**

EMISSION CONTROL WARRANTY COVERAGE IS APPLICABLE TO CERTIFIED ENGINES PURCHASED IN CALIFORNIA IN 1995 AND THEREAFTER, WHICH ARE USED IN CALIFORNIA, AND TO CERTIFIED MODEL YEAR 1997 AND LATER ENGINES WHICH ARE PURCHASED AND USED ELSEWHERE IN THE UNITED STATES (AND AFTER JANUARY 1, 2001 IN CANADA).

California and United States Emission Control Defects Warranty Statement

The California Air Resources Board (CARB), the U.S. Environmental Protection Agency (EPA), and Briggs & Stratton are pleased to explain the Emission Control Systems Warranty on your model year 2002 and later small off-road engine (SORE). In California, new small off-road engines must be designed, built and equipped to meet the State's stringent anti-smog standards. Elsewhere in the United States, new non-road, spark-ignition engines certified for model year 1997 and later must meet similar standards set forth by the U.S. EPA. B&S must warrant the emission control system on your engine for the periods of time listed below, provided there has been no abuse, neglect or improper maintenance of your small off-road engine.

Your emission control system includes parts such as the carburetor, air cleaner, ignition system, muffler and catalytic converter. Also included may be connectors and other emission related assemblies.

Where a warrantable condition exists, Briggs & Stratton will repair your small off-road engine at no cost to you, including diagnosis, parts and labor.

Briggs & Stratton Emission Control Defects Warranty Coverage

Small off-road engines are warranted relative to emission control parts defects for a period of two years, subject to provisions set forth below. If any covered part on your engine is defective, the part will be repaired or replaced Briggs & Stratton.

Owner's Warranty Responsibilities

As the small off-road engine owner, you are responsible for the performance of the required maintenance listed in the Operator's Manual. Briggs & Stratton recommends that you retain all your receipts covering maintenance on your small off-road engine, but Briggs & Stratton cannot deny warranty solely for the lack of receipts or for your failure to ensure the performance of all scheduled maintenance.

As the small off-road engine owner, you should however be aware that Briggs & Stratton may deny you warranty coverage if your small off-road engine or a part has failed due to abuse, neglect, improper maintenance or unapproved modifications.

You are responsible for presenting your small off-road engine to an authorized Briggs & Stratton service dealer as soon as a problem exists. The undisputed warranty repairs should be completed in a reasonable amount of time, not to exceed 30 days.

If you have any questions regarding your warranty rights and responsibilities, you should contact a B&S service representative at 1-414-259-5652.

The emission warranty is a defects warranty. Defects are judged on normal engine performance. The warranty is not related to an in-use emission test.

Briggs & Stratton Emission Control Defects Warranty Provisions

The following are specific provisions relative to your Emission Control Defects Warranty Coverage. It is in addition to the B&S engine warranty for non-regulated engines.

1. Warranted Parts — Coverage under this warranty extends only to the parts listed below (the emission control systems parts) to the extent these parts were present on the engine purchased.
 - a. Fuel Metering System
 - Cold start enrichment system
 - Carburetor and internal parts
 - Fuel pump
 - b. Air Induction System
 - Air cleaner
 - Intake manifold
 - c. Ignition System
 - Spark plug(s)
 - Magneto ignition system
 - d. Catalyst System
 - Catalytic converter
 - Exhaust manifold
 - Air injection system, Pulse valve
 - e. Miscellaneous Items
 - Vacuum, temperature, position, time sensitive valves and switches
 - Connectors and assemblies
2. Length of Coverage — Briggs & Stratton warrants to the initial owner and each subsequent purchaser that the Warranted Parts shall be free from defects in materials and workmanship which caused the failure of the Warranted Parts for a period of two years from the date the engine is delivered to a retail purchaser.
3. No Charge — Repair or replacement of any Warranted Part will be performed at no charge to the owner, including diagnostic labor which leads to the determination that a Warranted Part is defective, if the diagnostic work is performed at an authorized Briggs & Stratton service dealer. For emission warranty service contact your nearest authorized Briggs & Stratton service dealer as listed in the "Yellow Pages" under "Engines, Gasoline," "Gasoline Engines," "Lawn Mowers," or similar category.
4. Claims and Coverage Exclusions — Warranty claims shall be filed in accordance with the provisions of the B&S Engine Warranty Policy. Warranty coverage shall be excluded for failures of Warranted Parts which are not original Briggs & Stratton parts or because of abuse, neglect or improper maintenance as set forth in the B&S Engine Warranty Policy. Briggs & Stratton is not liable to cover failures of Warranted Parts caused by the use of add-on, non-original, or modified parts.
5. Maintenance — Any Warranted Part which is not scheduled for replacement as required maintenance or which is scheduled only for regular inspection to the effect of "repair or replace as necessary" shall be warranted as to defects for the warranty period. Any Warranted Part which is scheduled for replacement as required maintenance shall be warranted as to defects only for the period of time up to the first scheduled replacement for that part. Any replacement part that is equivalent in performance and durability may be used in the performance of any maintenance or repairs. The owner is responsible for the performance of all required maintenance, as defined in the Operator's Manual.
6. Consequential Coverage — Coverage hereunder shall extend to the failure of any engine components caused by the failure of any Warranted Part still under warranty.

CONTENTS

Section	Page	Section	Page
Emission Control Systems Warranty ...	2	VI Off-Season Storage	45
Tractor and Deck Preparation.....	3	VII Mowing.....	46
Safe Operation Practices	4	Optional Equipment and Accessories .	47
Product Graphics	7	Maintenance Chart.....	48
To The Owner	8	Trouble Shooting.....	49
Calling Service Information	8	Lubrication Table	51
Recording Model & Serial Number	8	Lubrication Guide.....	52
I Controls and Indicators	9	Slope Gauge	55
II Operation	14	Specifications.....	57
III Adjustments	18	Warranty — Commercial Use	58
IV Maintenance	23	Warranty — Residential Use	59
V Mower Deck.....	33	Maintenance Parts Chart	60

TRACTOR AND DECK PREPARATION

1. ATTACHING THE CHUTE DEFLECTOR

For shipping purposes, the mulching plug has been installed in the mower deck. The mulching plug must be removed to install the chute deflector assembly.



WARNING

Do not operate the mower deck, even with the mulching plug installed, unless the chute deflector has been properly installed.

1. Remove the wing nut and carriage bolt securing the mulching plug to the deck and withdraw the plug from the discharge opening of the deck.

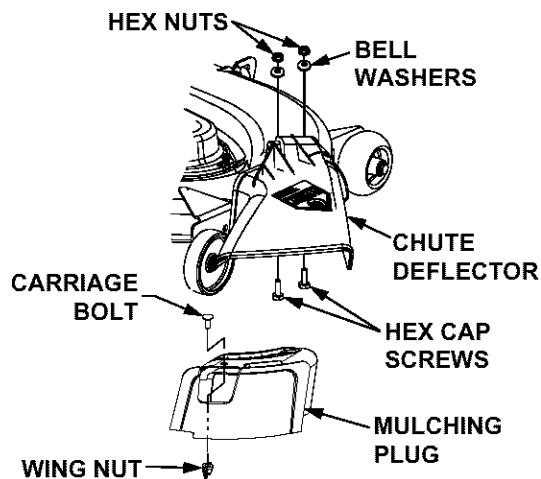

2. Remove the two hex nuts and bell washers from the hex cap screws installed in the deck at the chute opening.

3. Position the deflector assembly to align the holes of its hinge bracket with the two hex cap screws and slide the hinge bracket onto the screws. Secure with the two bell washers and hex nuts.

NOTE: The crowned (rounded) surface of the washers go toward the hex nuts.

4. Refer to **SECTION V-MOWER DECK** when re-installing the mulching plug.

2. CONNECT THE BATTERY



WARNING

Battery posts, terminals and related accessories contain lead and lead compounds. **Wash hands after handling.**

The tractor is shipped with an activated sealed battery. The positive battery cable is factory connected. The negative cable must be connected.

Note: Make sure the ignition switch is in the "OFF" position before attaching the battery cables.

1. Pull the protective cap off the negative terminal of the battery, and remove the hex cap screw and nut from the free end of the negative battery cable.
2. Connect the negative battery cable (heavy black) and ground wire (green) to negative terminal (—) of the battery using the hex cap screw and nut.
3. Slide the black terminal cover over the negative terminal of the battery.



WARNING

- The engine exhaust, some of its constituents, and certain vehicle components contain or emit chemicals known to the State of California to cause cancer, birth defects or other reproductive harm.
- This unit is equipped with an internal combustion engine and should not be used on or near any unimproved forest-covered, brush-covered, or grass-covered land unless the engine's exhaust system is equipped with a spark arrester meeting applicable local or state laws (if any). If a spark arrester is used, it should be maintained in effective working order by the operator.
- In the State of California, the above is required by law (Section 4442 of the California Public Resources Code). Other States may have similar laws. Federal laws apply to federal lands. A spark arrester muffler is available at your nearest engine authorized service center.

IMPORTANT

SAFE OPERATION PRACTICES



THIS SYMBOL POINTS OUT IMPORTANT SAFETY INSTRUCTIONS WHICH, IF NOT FOLLOWED, COULD ENDANGER THE PERSONAL SAFETY AND/OR PROPERTY OF YOURSELF AND OTHERS. READ AND FOLLOW ALL INSTRUCTIONS IN THIS MANUAL BEFORE ATTEMPTING TO OPERATE YOUR UNIT. FAILURE TO COMPLY WITH THESE INSTRUCTIONS MAY RESULT IN PERSONAL INJURY. WHEN YOU SEE THIS SYMBOL—  **HEED ITS WARNING.**



DANGER

Your lawn mower was built to be operated according to the rules for safe operation in this manual. As with any type of power equipment, carelessness or error on the part of the operator can result in injury. This lawn mower is capable of amputating hands and feet or throwing objects. Failure to observe the following safety instructions could result in serious injury or death.



I. GENERAL OPERATION

1. Read, understand and follow all instructions in the manual and on the machine before starting. Keep this manual in a safe place for future and regular reference.
2. Only allow responsible individuals familiar with the instructions to operate the machine. Know the controls and how to stop the machine quickly.
3. Do not put hands or feet under the cutting deck or near rotating parts.
4. Clear the area of objects such as rocks, toys, wire, etc. which could be picked up and thrown by the blades. A small object may have been overlooked and could be accidentally thrown by the mower in any direction and cause injury to you or a bystander. To help avoid a thrown objects injury, keep children, animals, bystanders and helpers at least 75 feet from the mower while it is in operation. Always wear safety glasses with side shields or safety goggles during operation or while performing an adjustment or repair, to protect eyes from foreign objects. Stop the blades when crossing gravel drives, walks or roads.
5. Be sure the area is clear of other people before mowing. Stop machine if anyone enters the area.
6. Never carry passengers.
7. Disengage the blades before shifting into reverse and backing up. Always look down and behind before and while backing.
8. Be aware of the mower and attachment discharge direction and do not point it at anyone. Do not operate the mower without either the entire grass catcher or the chute guard in place.
9. Slow down before turning. Operate the machine smoothly. Avoid erratic operation and excessive speed.
10. Never leave a running machine unattended. Always turn off the blades, place the transmission in neutral, set the parking brake, stop the engine and remove key before dismounting.
11. Turn off blades when not mowing.
12. Stop the engine and wait until the blades come to a complete stop before (a) removing the grass catcher or unclogging chute, or (b) making any repairs, adjusting or removing any grass or debris.

13. Mow only in daylight or good artificial light.
14. Do not operate the machine while under the influence of alcohol or drugs.
15. Watch for traffic when operating near or crossing roadways.
16. Use extra care when loading or unloading the machine into a trailer or truck. This unit should not be driven up or down a ramp onto a trailer or truck under power, because the unit could tip over causing serious personal injury. The unit must be pushed manually on a ramp to load or unload properly.
17. Never make a cutting height adjustment while the engine is running if the operator must dismount to do so.
18. Wear sturdy, rough-soled work shoes and close-fitting slacks and shirts. Do not wear loose fitting clothes or jewelry. They can be caught in moving parts. Never operate a unit in bare feet, sandals or sneakers.
19. Check overhead clearance carefully before driving under power lines, wires, bridges or low hanging tree branches, before entering or leaving buildings, or in any other situation where the operator may be struck or pulled from the unit, which could result in serious injury.
20. Disengage all attachment clutches, thoroughly depress the brake pedal and shift into neutral before attempting to start the engine.
21. Your mower is designed to cut normal residential grass of a height no more than 10". Do not attempt to mow through unusually tall, dry grass (e.g. pasture) or piles of dry leaves. Debris may build up on the mower deck or contact the engine exhaust presenting a potential fire hazard.
22. Use only accessories approved for this machine by *Cub Cadet*. Read, understand and follow all instructions provided with the approved accessory.

II. SLOPE OPERATION

Slopes are a major factor related to loss of control and tip-over accidents, which can result in severe injury or death. **All** slopes require extra caution. If you cannot back up the slope or if you feel uneasy on it, do not mow it.

For your safety, use the slope gauge included as part of this manual to measure slopes before operating this unit on a sloped or hilly area. If the slope is greater than 15° as shown on the slope gauge, do not operate this unit on that area or serious injury could result.

DO:

Mow up and down slopes, not across.

Remove obstacles such as rocks, limbs, etc.

Watch for holes, ruts or bumps. Uneven terrain could overturn the machine. **Tall grass can hide obstacles.**

Use slow speed. Choose a low enough gear so that you will not have to stop or shift while on the slope. Always keep the machine in gear when going down slopes to take advantage of engine braking action.

Follow the manufacturer's recommendations for wheel weights or counterweights to improve stability.

Use extra care with grass catchers or other attachments. These can change the stability of the machine.

Keep all movement on the slopes **slow** and **gradual**. Do not make sudden changes in speed or direction. Rapid engagement or braking could cause the front of the machine to lift and rapidly flip over backwards, which could cause serious injury.

Avoid starting or stopping on a slope. If the tires lose traction, disengage the blades and proceed slowly **straight** down the slope.

DO NOT:

Do not turn on slopes unless necessary; then, turn slowly and gradually downhill, if possible.

Do not mow near drop-offs, ditches or embankments. The mower could suddenly turn over if a wheel is over the edge of a cliff or ditch, or if an edge caves in.

Do not mow on wet grass. Reduced traction could cause sliding.

Do not try to stabilize the machine by putting your foot on the ground.

Do not use the grass catcher on steep slopes.

III. CHILDREN

Tragic accidents can occur if the operator is not alert to the presence of children. Children are often attracted to the machine and the mowing activity. **Never** assume that children will remain where you last saw them.

1. Keep children out of the mowing area and in watchful care of an adult other than the operator.
2. Be alert and turn the machine off if children enter the area.
3. Before and when backing up, look behind and **down** for small children.
4. Never carry children, even with the blades off. Children may fall off and be seriously injured or may interfere with safe machine operation.

5. Never allow children under 14 years old to operate the machine. Children 14 years and over should only operate the machine under close parental supervision and proper instruction.
6. Use extra care when approaching blind corners, shrubs, trees or other objects that may obscure your vision of a child or other hazard.
7. Remove the key when the machine is left unattended to prevent unauthorized operation.



IV. SERVICE

1. Use extreme care in handling gasoline and other fuels. They are extremely flammable and the vapors are explosive.
 - a. Use only an approved container.
 - b. Never remove fuel cap or add fuel with the engine running. Allow the engine to cool at least two minutes before refueling.
 - c. Replace the fuel cap securely and wipe off any spilled fuel before starting the engine as it may cause a fire or explosion.
 - d. Extinguish all cigarettes, cigars, pipes and other sources of ignition.
 - e. Never refuel the machine indoors because fuel vapors will accumulate in the area.
 - f. Never store the fuel container or machine inside where there is an open flame or spark, such as a gas hot water heater, space heater or furnace.
2. Never run a machine inside a closed area.
3. To reduce fire hazard, keep the machine free of grass, leaves or other debris build-up. Clean up oil or fuel spillage. Allow the machine to cool at least 5 minutes before storing.
4. Before cleaning, repairing or inspecting, make certain the blade and all moving parts have stopped. Disconnect the spark plug wire, and keep the wire away from the spark plug to prevent accidental starting.
5. Check the blade and engine mounting bolts at frequent intervals for proper tightness. Also visually inspect blades for damage (e.g., excessive wear, bent, cracked). Replace with blades which meet original equipment specifications.
6. Keep all nuts, bolts and screws tight to be sure the equipment is in safe working condition.
7. Never tamper with safety devices. Check their proper operation regularly. Use all guards as instructed in this manual.
8. After striking a foreign object, stop the engine, remove the wire from the spark plug and thoroughly inspect the mower for any damage. Repair the damage before restarting and operating the mower.
9. Grass catcher components are subject to wear, damage and deterioration, which could expose moving parts or allow objects to be thrown. For your safety protection, frequently check the components and replace with manufacturer's recommended parts when necessary.
10. Mower blades are sharp and can cut. Wrap the blades or wear gloves, and use extra caution when servicing blades.
11. Check brake operation frequently. Adjust and service as required.
12. Muffler, engine and belt guards become hot during operation and can cause a burn. Allow to cool down before touching.
13. Do not change the engine governor settings or overspeed the engine. Excessive engine speeds are dangerous.
14. Observe proper disposal laws and regulations. Improper disposal of fluids and materials can harm the environment and the ecology.
 - a. Prior to disposal, contact your local Environmental Protection Agency to determine the proper method for disposing of the waste. Recycling centers are established to properly dispose of materials in an environmentally safe fashion.
 - b. Use proper containers when draining fluids. Do not use food or beverage containers that may mislead someone into drinking from them. Properly dispose of the containers immediately following the draining of fluids.
 - c. DO NOT pour oil or other fluids into the ground, down a drain or into a stream, pond, lake, or other body of water. Observe Environmental Protection Agency regulations when disposing of oil, fuel, coolant, brake fluid, filters, batteries, tires and other harmful waste.
15. We do not recommend the use of a pressure washer or garden hose to clean your unit. They may cause damage to electrical components; spindles; pulleys; bearings; or the engine. The use of water will result in shortened life and reduce serviceability.



WARNING - YOUR RESPONSIBILITY: Restrict the use of this power machine to persons who read, understand and follow the warnings and instructions in this manual and on the machine.

PRODUCT GRAPHICS

Keep product safety graphics (decals) clean. Replace any safety graphic that is damaged, destroyed, miss-

ing, painted over or can no longer be read. Replacement safety graphics are available through your dealer.

STARTING INSTRUCTIONS

1. BE FAMILIAR WITH CONTROLS BEFORE STARTING ENGINE AND OPERATING.
2. SET CHOKE, MOVE THROTTLE TO MID POSITION AND DEPRESS BRAKE PEDAL.
3. TURN KEY TO THE START POSITION.
4. AFTER ENGINE STARTS OPEN CHOKE.

STOPPING INSTRUCTIONS

1. DISENGAGE PTO AND SET PARKING BRAKE.
2. MOVE THROTTLE CONTROL TO MID POSITION AND TURN KEY OFF.

WARNING

- AVOID SERIOUS INJURY OR DEATH.
- READ OPERATORS MANUAL AND ALL WARNING LABELS BEFORE USING MACHINE.
- GO UP AND DOWN SLOPES, NOT ACROSS.
- AVOID SUDDEN TURNS.
- DO NOT OPERATE UNIT WHERE IT COULD SLIP OR TIP.
- IF MACHINE STOPS GOING UPHILL, STOP PTO AND BACK DOWN HILL SLOWLY.
- DO NOT MOW WHEN CHILDREN OR OTHERS ARE AROUND.
- NEVER CARRY CHILDREN.
- LOOK DOWN AND BEHIND BEFORE AND WHILE BACKING.
- KEEP SAFETY DEVICES (GUARDS, SHIELDS, AND SWITCHES) IN PLACE AND WORKING.
- REMOVE OBJECTS THAT COULD BE THROWN BY THE BLADES.
- KNOW LOCATION AND FUNCTION OF ALL CONTROLS.
- BE SURE THE BLADES AND THE ENGINE ARE STOPPED BEFORE PLACING HANDS OR FEET NEAR BLADES.
- BEFORE LEAVING OPERATOR'S POSITION, DISENGAGE PTO, ENGAGE BRAKE LOCK, SHUT OFF ENGINE AND REMOVE KEY.

GENERAL SAFETY INSTRUCTIONS WARNING – LOCATED ON RIGHT SIDE OF RUNNING BOARD

DANGER

AVOID SERIOUS INJURY OR DEATH

- KEEP HANDS AND FEET AWAY FROM ROTATING PARTS.
- REMOVE OBJECTS THAT CAN BE THROWN BY THE BLADE IN ANY DIRECTION. WEAR SAFETY GLASSES.
- DO NOT MOW WHEN CHILDREN OR OTHERS ARE AROUND. NEVER CARRY CHILDREN.
- USE EXTRA CAUTION ON SLOPES. DO NOT MOW SLOPES GREATER THAN 15° MOW UP AND DOWN. NOT ACROSS. AVOID SUDDEN TURNS, USE LOW GEAR.

MAX 15°

READ OPERATOR'S MANUAL. KEEP SAFETY DEVICES WORKING.

SAFETY GRAPHIC – LOCATED ON LEFT SIDE OF MOWER DECK

DANGER

KEEP HANDS AND FEET AWAY. DO NOT OPERATE MOWER UNLESS CHUTE DEFLECTOR OR ENTIRE GRASS CATCHER IS IN ITS PROPER PLACE.

ASSEMBLE CHUTE DEFLECTOR TO THIS UNIT BEFORE OPERATING.

DEFLECTOR and SAFETY GRAPHIC – LOCATED ON RIGHT SIDE OF DECK

TO REDUCE THE RISK OF INJURY, DO NOT OPERATE MOWER UNLESS DISCHARGE CHUTE COVER OR GRASS CATCHER IS IN ITS PROPER PLACE.

DANGER

KEEP HANDS and FEET AWAY

HANDS AND FEET SAFETY GRAPHIC – LOCATED ON DEFLECTOR CHUTE

CAUTION

- UNDER SPRING TENSION
- HOLD LEVER SECURELY
- REFER TO OPERATOR'S MANUAL

SAFETY GRAPHIC – LOCATED ON LEFT SIDE OF DECK

TO THE OWNER

This Operator's Manual is an important part of your new tractor. The information contained in this manual has been prepared in detail to help you better understand the features, correct operation, adjustments, and maintenance of your tractor. The performance and dependability of this tractor rely greatly on the manner in which it is operated and maintained. Therefore, it is recommended that all operators of the tractor carefully read this manual and fully understand its operation. Also keep the manual available for reference to ensure proper operation, and that maintenance procedures are performed as scheduled to assure the tractor's optimal mechanical condition.

NOTE: All references to *LEFT*, *RIGHT*, *FRONT*, and *REAR*, unless specifically stated otherwise, indicate that relative position on the tractor when facing forward while seated in the operator's seat.

CAUTION: DO NOT tow your Model LT 2180 tractor. Towing may damage the transmission. Place the tractor on a LEVEL SURFACE before pulling the transmission release lever to the disengaged position.

Your local authorized *Cub Cadet* dealer is interested in the performance you receive from your tractor, and with the maintenance needed to ensure the satisfactory operation of your tractor. The dealer has trained service personnel familiar with the latest servicing information, is equipped with the latest tools, and has a complete line of genuine *Cub Cadet* service parts which assure proper fit and high quality.

CALLING SERVICE INFORMATION

The engine manufacturer is responsible for all engine-related issues with regards to performance, power-rating, and specifications.

If you have difficulties with the tractor and/or equipment; have any questions regarding the operation or maintenance of this equipment; or desire additional information not found in this manual, contact your nearest authorized *Cub Cadet* dealer. If you need assistance in locating a dealer in your area, contact the Customer Dealer Referral Line by calling:

1-877-282-8684

Or you may contact Cub Cadet via the internet by logging on to our Web Site at:

www.cubcadet.com

To obtain top performance and assure economical operation, the tractor should be inspected by your authorized dealer periodically or at least once a year, depending on its hours of use. Before calling your dealer, make sure that you have your model number(s) and manufacturing date available for the dealer.

RECORDING MODEL AND SERIAL NUMBER INFORMATION

Product identification plates are provided for major components of your tractor. The numbers on these plates are important if your tractor should require dealer service, or if you need additional information on your tractor. Prior to using your tractor for the first time, record the numbers from the identification plates in the appropriate spaces provided below.

The chassis model plate, showing the factory model number and Mfg. Date (See Figure 1) can be found on the underside of the seat mounting base. Pivot the seat forward to locate the decal.

The engine serial number decal (See Figure 2) is located on the engine blower housing.

Hood Model _____ Factory Model No. _____ Mfg. Date _____

Delivery Date _____ Engine Model/Type _____ Code. _____

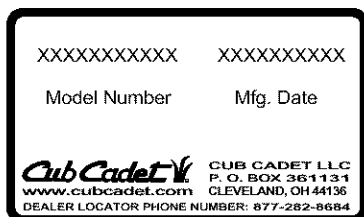

Figure 1

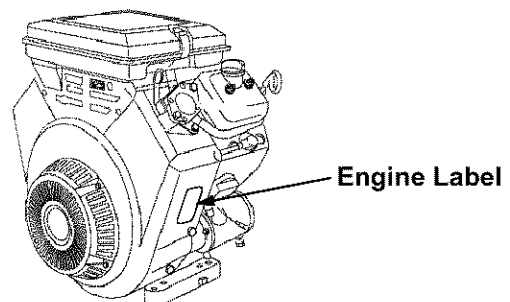
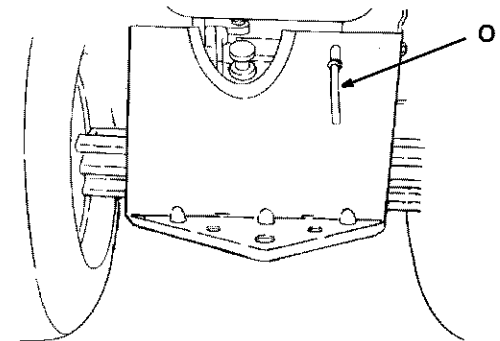
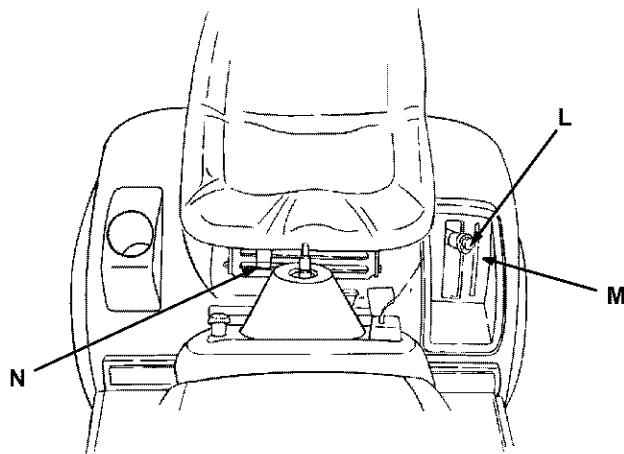
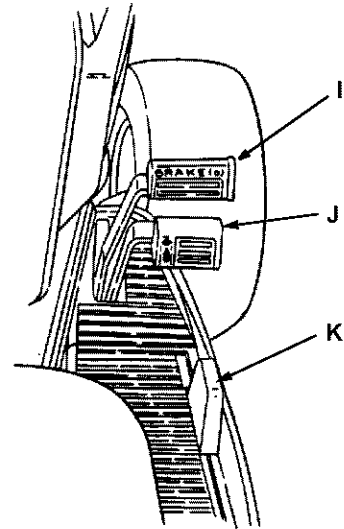
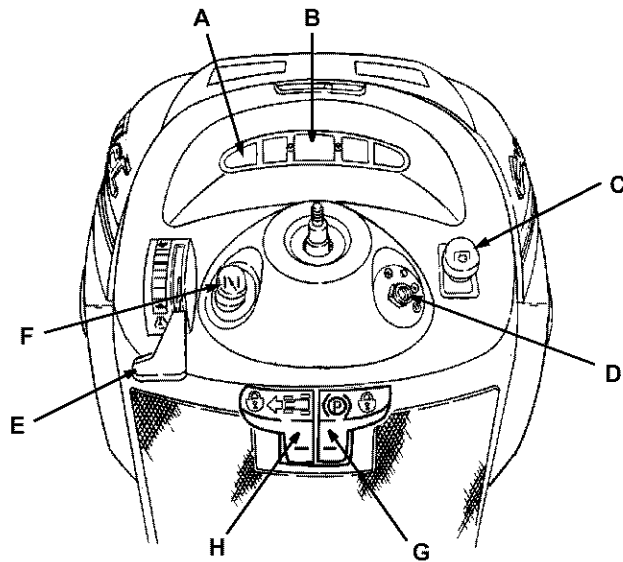

Figure 2

SECTION I. CONTROLS AND INDICATORS

Your Cub Cadet Tractor has been safety engineered. This section gives a brief description of the function and location of the various controls and indicators.

Thoroughly acquaint yourself with all the controls and indicators before attempting to start or operate the tractor.



- A. Low Oil Indicator
- B. Hour Meter
- C. Power Take-Off (PTO) Control Switch
- D. Ignition/Light Switch
- E. Throttle Control Lever
- F. Choke Control
- G. Brake Pedal Lock
- H. Cruise Control Lever

- I. Brake Pedal
- J. Forward Control Pedal
- K. Reverse Control Pedal
- L. Lift Handle
- M. Lift Height Indicator
- N. Seat Adjustment Lever
- O. Transmission Release Lever
- P. Fuses (Not Shown)
- Q. Safety Interlock Switches (Not Shown)

Figure 3

A. LOW OIL INDICATOR

This indicator will illuminate when the engine oil level is low. If this indicator illuminates, stop the tractor immediately and check the engine oil level. If the oil level is within the operating range, but the light remains on, contact your *Cub Cadet* dealer.



CAUTION

Operating the tractor with low oil level or pressure could result in severe engine damage.

B. HOUR METER

The hour meter operates whenever the ignition key is in the "ON" position. Record the actual hours of tractor operation to ensure all maintenance procedures are completed according to the schedule in this manual.

C. POWER TAKE-OFF (PTO) CONTROL SWITCH

The power take-off control switch operates the front electric PTO clutch. Pull the switch knob to engage ("RUN"), or push the knob to disengage ("OFF") the PTO clutch.

D. IGNITION/LIGHT SWITCH



WARNING

To prevent accidental starting and/or battery discharge, remove the key from the ignition switch when the tractor is not in use.

The combination lights and ignition switch is a four position switch. (See Figure 4)

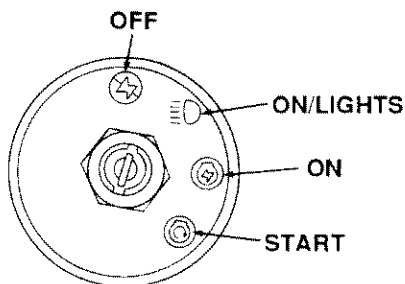

Figure 4

E. THROTTLE CONTROL LEVER

This lever controls the speed of the engine. When set in a given position, the control cable will maintain a uniform engine speed.



NOTE

When using power take-off operated equipment, best performance is achieved with the throttle lever in the "FAST" position.



This symbol shows slow position.



This symbol shows fast position.

F. CHOKE CONTROL

The choke control is operated manually. Pull the knob out to choke the engine; push the knob in to open the choke.

G. BRAKE PEDAL LOCK



WARNING

The hydrostatic transmission will not hold the tractor on a hill. Normal internal leakage in the transmission will allow the tractor to roll downhill. To avoid an accident and/or possible injury, engage the brake pedal lock.

The brake lock lever, located in the center of the dash panel below the steering wheel, is identified with the (P) symbol. Always engage the brake pedal lock when dismantling the tractor. To engage the brake pedal lock, depress the brake pedal and push down on the brake pedal lock lever. Hold the lever down while releasing the brake pedal. The lever should lock in the down position.

H. CRUISE CONTROL LEVER

The cruise control lever, located in the center of the dash panel below the steering wheel, is identified with the symbol. This lever can be used to maintain a desired "foot free" **forward speed** in areas where constant speed changes are not required. Refer to **Section II- OPERATION** for instructions on how to use this feature.

I. BRAKE PEDAL

The brake pedal is located at the front of the right running board above the forward control pedal. Press down to stop the tractor and disengage the cruise control. The brake pedal must be fully depressed to activate the safety interlock switch when starting the tractor.

J. FORWARD CONTROL PEDAL

The forward control pedal is located at the front of the right running board below the brake pedal. Slowly press down on the pedal to start moving forward. The forward ground speed of the tractor is directly affected by the distance the pedal is depressed.

K. REVERSE CONTROL PEDAL



WARNING

Check behind the tractor to be sure the area is clear of people, pets or obstacles. Use a slower speed to maintain control of the tractor when traveling in reverse.

The reverse control pedal is located in the right front running board rearward of the the brake and forward control pedals. Press the pedal downward to move in reverse.

L. LIFT HANDLE

The lift handle is located in the left fender and is used to raise and lower equipment used with the tractor. The equipment can be set in any of six positions by depressing the top button on the handle, moving the handle to the desired position, then releasing the button. It may be necessary to push or pull slightly on the handle to depress the button. There is a lift assist spring which reduces the effort needed to lift attachments. To adjust spring tension refer to **ADJUSTMENTS** in Section III.

M. LIFT HEIGHT INDICATOR

The lift height indicator is located in the left fender and indicates the height of the deck attachment when installed.

N. SEAT ADJUSTMENT LEVER

The seat adjustment lever (see Figure 5) is used to move the seat forward or rearward into one of five positions. See **ADJUSTING THE SEAT** in Section III.

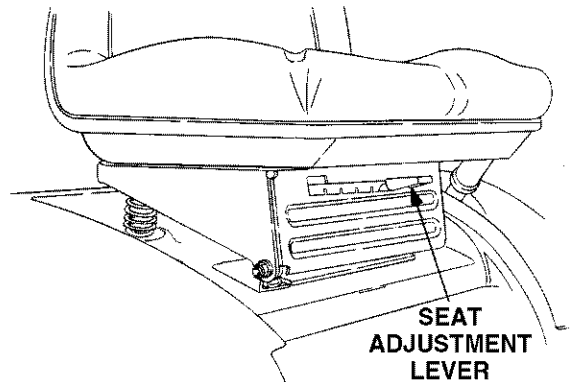

Figure 5

O. TRANSMISSION RELEASE LEVER

The transmission release lever is located at the back of the tractor in the rear drawbar. This lever disconnects the hydro transmission pump from the rear axle to allow the unit to be pushed a short distance by hand.

To disengage the transmission, pull back on the lever until its locking flange is visible outside the drawbar, then lift the lever up into the slot and release. To re-engage the transmission, pull back on the lever, drop out of the slot and release.

P. FUSES

The fuses are located under the hood between the indicator lamps and the hour meter (see Figure 6). Fuses are installed to protect the tractor's electrical circuitry and components from damage caused by excessive amperage.

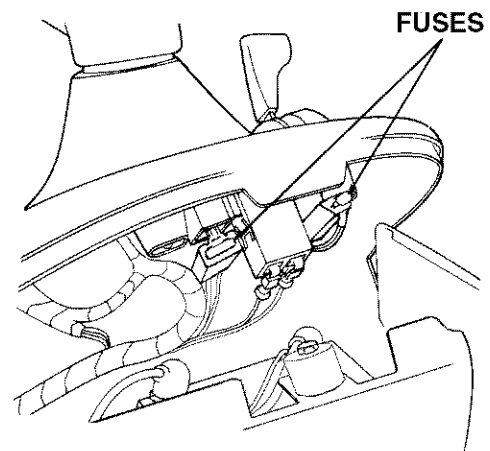

Figure 6

Q. SAFETY INTERLOCK SWITCHES

This tractor is equipped with a safety interlock system for the protection of the operator. If the interlock system should ever malfunction, do not operate the tractor. Contact your authorized *Cub Cadet* Dealer. The safety interlock system prevents the engine from cranking or starting unless the brake pedal is fully depressed, and the PTO switch is in the "OFF" position.

The safety interlock system will automatically shut off the engine if the operator leaves the seat before engaging the brake lock.

The safety interlock system will automatically shut off the engine if the operator leaves the seat with the PTO in the "RUN" position, regardless of whether the brake lock is engaged. The PTO switch must be moved to the "OFF" position to restart the engine.

The safety interlock system will automatically shut off the PTO if the *reverse control pedal* is depressed with the PTO in the "RUN" position. To re-engage the PTO, release the reverse control pedal, move the PTO switch to the "OFF" position, then again pull the switch to the "RUN" position.

FUEL TANK

The fuel tank is located under the rear fender. The filler cap is in the center/rear of the fender (see Figure 7).

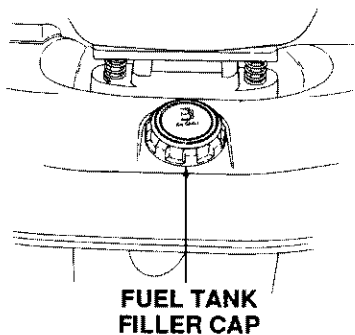

Figure 7

HOOD AND SIDE PANELS

The tractor hood is arranged to swing up and forward for easy access to the engine compartment (see Figure 8). Whenever engine maintenance is required, the side panels can be removed.



WARNING

If the engine has been recently run, the engine, muffler and surrounding metal surfaces will be hot and can cause burns to the skin. Allow the tractor to cool and use caution when removing the side panels.

To remove either the right or left side panel, refer to Figure 8 and proceed as follows:

1. Engage the brake lock and raise the hood.
2. Loosen, but do not remove, the rear wing nut and upper front wing nut.
3. Grasp the side panel just behind the grille and pull outward to release the side panel from the tapered bushings on the grille.
4. Slide the side panel forward and out of the groove in the dash panel.

To install either the right or left side panel, refer to Figure 8 and proceed as follows:

1. Slide the rear of panel into the groove in the dash panel.
2. Position the notch of the rear side panel tab on the threads of the bulkhead rod, between the bulkhead and wing nut.
3. Press the slots of the front side panel flange onto the tapered retainers, between the retainers and the grille.
4. Tighten the rear and upper front wing nuts and close the hood.

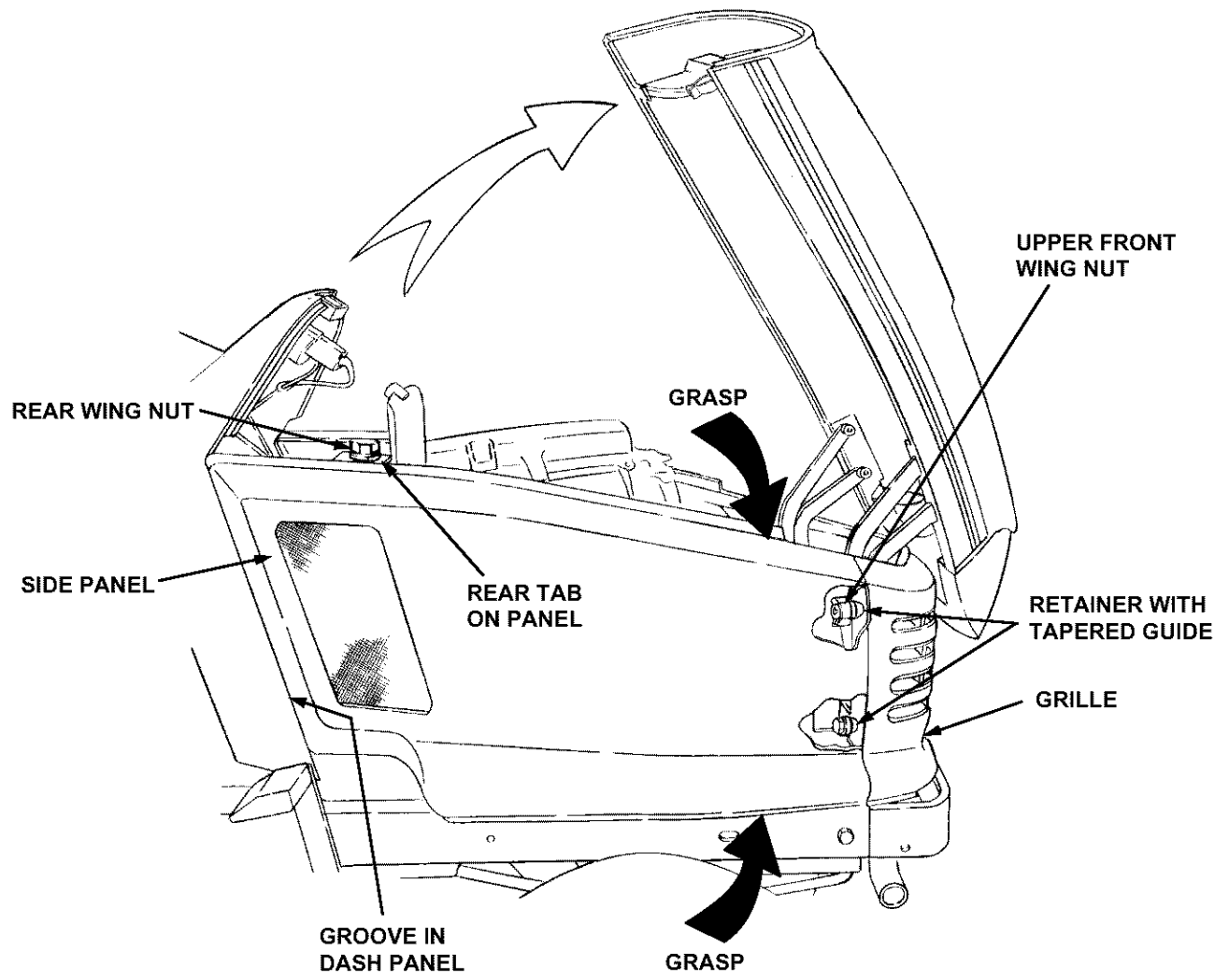

Figure 8

SECTION II. OPERATION



WARNING

Receive Instruction - Read the operator's manual. Learn to operate this machine SAFELY. Don't risk INJURY or DEATH.

1. Before starting the engine or beginning operation, be familiar with the controls. The operator must be seated, the PTO switch in the "OFF" position and the brake pedal fully depressed.
2. Keep all shields in place. Keep away from moving parts.
3. NO RIDERS! Keep all people and pets a safe distance away. Look behind to both sides before backing up.
4. DO NOT direct the mower discharge at people.
5. Avoid slopes. Tractors can be rolled over.
6. Before leaving the operator's seat: Shut off the PTO, engage the brake pedal lock, shut off the engine and remove the ignition key. Wait for all movement to stop before servicing or cleaning.
7. Do not fill the fuel tank when the engine is running or while the engine is hot. Tighten the fuel cap securely.

BEFORE OPERATING YOUR TRACTOR

1. Before you operate the tractor, study this manual carefully. It has been prepared to help you operate and maintain your tractor with utmost efficiency.
2. Familiarize yourself with the operations of all the instruments and controls.
3. This engine is certified to operate on unleaded gasoline. Fill the fuel tank with only clean, fresh, unleaded gasoline with a minimum of 85 octane. Do not mix oil with gasoline. Purchase fuel in a quantity that can be used within 30 days to assure fuel freshness.

In countries other than the U.S.A., leaded gasoline may be used if it is commercially available and unleaded is not available.

NOTE: *Some fuels, called oxygenated or reformulated gasolines, are gasoline blended with alcohols or ethers. Excessive amounts of these blends can damage the fuel system or cause performance problems. Do not use gasoline which contains Methanol. If any undesirable operating symptoms occur, use gasoline with a lower percentage of alcohol or ether.*

4. Check the engine and transmission oil levels.
5. Clean the air cleaner element if necessary.

6. Check the tire inflation pressures.
7. Adjust the seat for operator's maximum comfort, visibility and for maintaining complete control of the tractor.
8. Remove the side panels and clean any accumulated grass and debris from the engine air inlet screen. Also clean the dash air intake screen, grille and side panels to ensure adequate cooling.
9. Refer to the various sections of the Owner's Manual for additional information.

STARTING THE ENGINE



WARNING

For personal safety, the operator must be sitting in the tractor seat when starting the engine.



WARNING

This unit is equipped with a safety interlock system designed for the protection of the operator. Do not operate the tractor if any part of the interlock system is malfunctioning. Periodically check the functions of the interlock system for proper operation as described below:

- The safety interlock system prevents the engine from cranking or starting unless the brake pedal is fully depressed and the PTO clutch engagement switch is in the "OFF" position.
- The safety interlock system will automatically shut off the engine if the operator leaves the seat before engaging the brake pedal lock.
- The safety interlock system will automatically disengage the PTO if the reverse control pedal is pressed down with the PTO in the "RUN" position. To re-engage the PTO, release the reverse control pedal, move the PTO switch into the "OFF" position and then engage the PTO while seated.
- The safety interlock system will automatically shut off the tractor engine if the operator leaves the seat with the PTO in the "RUN" position.

1. Operator must be sitting in the tractor seat.
2. Pull choke control knob to full choke position. Less choking may be necessary due to variations in temperature, grade of fuel, etc. Little or no choking will be needed when the engine is warm.
3. Move the throttle lever to the "FAST" position.
4. Place the PTO switch in the "OFF" position.
5. Fully depress the brake pedal.
6. Turn the ignition key clockwise to the "START" position and release it as soon as the engine starts; however, do not crank the engine continuously for more than 5 seconds at a time. If the engine does not start within this time, turn the key "OFF" and wait a minute to allow the engine's starter motor to cool, then try again.
7. After the engine starts, slowly release the brake pedal. As the engine warms up, gradually push the choke control knob all the way in. Do not use the choke to enrich the fuel mixture, except as necessary to start the engine.

 **NOTE**

This engine is designed to give maximum performance and service life if operated with the choke fully open and the throttle in the "FAST" position. To open the choke fully requires an engine warmup period of several seconds to several minutes, depending on the outdoor temperature.

After starting the engine, push in the choke control until the engine begins to run smoothly. As the engine warms and begins to run roughly, continue to push in the choke control as necessary to keep the engine running smoothly until the choke is fully depressed. Operating equipment during engine warmup is not recommended.

STOPPING THE ENGINE

 **CAUTION**

Remove the key from the ignition switch to prevent accidental starting or battery discharge if the equipment is left unattended.

Place the PTO switch in the "OFF" position. Move the throttle control lever between the "MID" and "FAST" positions. Wait a moment to allow the engine speed to stabilize, then turn the ignition key to the "OFF" position. Remove the key from the ignition switch.

TRACTOR BREAK-IN PROCEDURE

 **CAUTION**

Never operate a new engine immediately under full load. Break it in carefully as shown in the table below.

Period	Engine Throttle Control Lever Position			Load
	1/2	3/4	Full	
1st hour		X		None
2nd hour	X		X	Light drawbar load or Mowing with tractor at slow groundspeed
3rd through 12th hour		X	X	Medium drawbar load or Normal mowing

COLD WEATHER STARTING

 **WARNING**

Engine exhaust gases are dangerous. Do not run the engine in a confined area such as a storage building any longer than is necessary. Immediately move the tractor outdoors.

 **WARNING**

For personal safety, the operator must be sitting in the tractor seat before starting the tractor.

When starting the engine at temperatures near or below freezing, ensure the correct viscosity motor oil is used in the engine and the battery is fully charged. Start the engine as follows:

1. Pull the choke all the way out to full choke position.
2. Move the throttle control lever to the "FAST" position.
3. Place the PTO switch in the "OFF" position.
4. Fully depress the brake pedal.

5. Turn the ignition key to the "START" position and hold until the engine starts; however, do not crank the engine continuously for more than 5 seconds at a time. Once the engine starts, gradually adjust the choke as needed to keep the engine running until warmed up, then push the choke control all the way in.

NOTE

If the engine fails to start after several attempts, the engine may become flooded. If this happens, wait a minute to allow the starter motor to cool. Move the throttle control to the "SLOW" position, push the choke in all the way and momentarily crank the engine to help clear the cylinders. With the throttle control in the "SLOW" position and the choke all the way in, turn the ignition key to the "START" position while slowly pulling the choke out to a position that will allow the engine to start. Gradually adjust the choke as needed to keep the engine running until warmed up, then push the choke control all the way in.

DRIVING THE TRACTOR

CAUTION

Avoid sudden starts, excessive speed and sudden stops.

CAUTION

Do not leave the seat of the tractor without disengaging the PTO, depressing the brake pedal and engaging the brake pedal lock. If leaving the tractor unattended, also turn the ignition key off and remove the key.

NOTE

When using power take-off operated equipment, best performance is achieved with the throttle lever in the "FAST" position.

1. Depress the brake pedal to release the brake pedal lock and let the pedal up. Move the throttle lever to the position where the engine operates best for the load to be handled.
2. Driving with forward or reverse pedals.

CAUTION

Do not use the forward or reverse control pedals to change the direction of travel when the tractor is in motion. Use the brake pedal to bring the tractor to a stop before depressing either the forward or reverse control pedal.

- a. To move forward, slowly depress the forward control pedal until the desired speed is achieved.
 - b. To move in reverse, check that the area behind is clear then fully depress the reverse control pedal.
3. Using the cruise control lever.

NOTE

The cruise control feature can only be operated in the forward direction.

- a. Slowly depress the forward control pedal until the desired speed is achieved.
- b. Lightly push the cruise control lever downward as far as possible and hold in this position.
- c. While continuing to hold the cruise lever down, lift your foot from the forward control pedal (you should feel the cruise latch engage).
- d. If properly engaged, the cruise lever and forward control pedal should lock in the down position, and the tractor will maintain the same forward speed.
- e. Disengage the cruise control using one of the following methods:
 - Depress the brake pedal to disengage the cruise control and stop the tractor.
 - Lightly depress the forward control pedal.
 - Lift the cruise control lever upward.

NOTE

Although not recommended, depressing the reverse pedal will also disengage the cruise control.

- f. To change to the reverse direction when operating with cruise control, depress the brake pedal to disengage the cruise control and stop the tractor; then depress the reverse control pedal.

DRIVING ON SLOPES

Refer to the SLOPE GAUGE on page 55 to help determine slopes where you may not operate safely.



WARNING

Do not mow on inclines with a slope in excess of 15 degrees (a rise of approximately 2-1/2 feet every 10 feet). The tractor could overturn and cause serious injury.



WARNING

Operate the tractor up and down slopes, never across slopes. Always drive up or down the face of a slope. Do not drive so that the tractor may tip over sideways.

Before operating the tractor on any slope, walk the slope to look for possible hazards such as rocks, mounds, ruts, stumps or other surface irregularities which could cause the tractor to be upset.

Back the tractor with implement up the steepest portion of each slope you intend to work. If the tractor cannot negotiate the slope in reverse, the slope is too steep to be worked.

Avoid turns when driving on a slope. If a turn must be made, turn **down** the slope. Turning up a slope greatly increases the chance of a roll over.

Avoid stopping when driving up a slope. If it is necessary to stop while driving up a slope, start up smoothly and carefully to reduce the possibility of flipping the tractor over backward.

STOPPING THE TRACTOR



CAUTION

Always engage the brake pedal lock, push the PTO switch to the "OFF" position, lower the equipment and shut off the engine before dismounting. Never try to start the engine while standing on the ground.

Fully depress the brake pedal to bring the tractor to a complete stop (and disengage the cruise control), engage the brake pedal lock, disengage the PTO, turn the ignition switch to "OFF" and remove the key from the switch before dismounting.

OPERATING THE POWER TAKE-OFF (PTO) CLUTCH

Before operating the new clutch under load (mowing grass, etc.), perform the following break-in procedure:

1. Start and run the engine a few minutes to warm up.
2. With the mowing deck, snow thrower, etc. installed and the engine running at approximately 50% throttle, engage and disengage the clutch at ten second intervals (ten seconds ON-ten seconds OFF) five times. The engine choke may have to be pulled out slightly to accomplish this.
3. Increase the engine speed to 75% throttle and again engage and disengage the PTO clutch at ten second intervals five times.
4. Make certain the PTO is disengaged and stop the engine.

Operate the PTO clutch as follows:

1. Move the throttle control lever to approximately the mid throttle position.
2. Pull the PTO switch to the "RUN" position.
3. Advance the throttle lever to the operating speed (full engine speed).
4. The operator must remain in the tractor seat at all times. If the operator should leave the seat without turning off the power take-off switch, the tractor's engine will shut off.
5. The PTO clutch cannot be operated when the tractor is driving in the reverse direction. The PTO switch must in the "OFF" position when the reverse control pedal is depressed, or the PTO clutch will automatically disengage. To re-engage the PTO clutch, release the reverse control pedal, move the PTO switch to the "OFF" position, then again pull the switch to the "RUN" position.

DRAWBAR

Drawbar type equipment must be hitched to the tractor only at the hitch hole in the drawbar (See Figure 9).

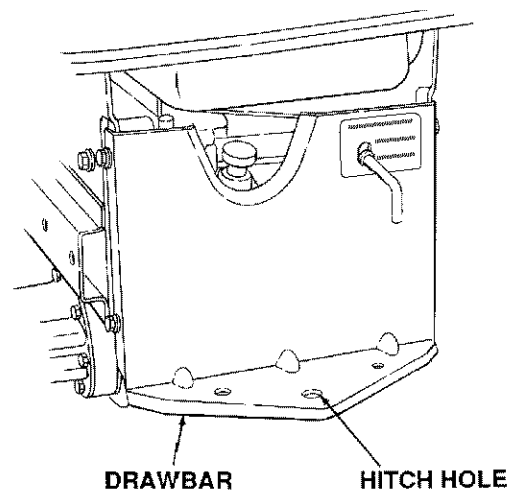

Figure 9

SECTION III. ADJUSTMENTS

This section contains adjustment information for the Model LT 2180 tractor. Adjustment information for the 42-inch deck is located in Section V – Mower Deck beginning on page 33.

ADJUSTING THE SEAT



WARNING

Do not adjust the seat when the tractor is moving. Adjusting the seat while the tractor is moving could cause the operator to lose control of the tractor.

Before starting the tractor, adjust the seat forward or rearward to the most comfortable driving position. To reposition the seat, move the seat adjustment lever (see Figure 10) upward and slide the seat forward or rearward. Release the adjustment lever when the seat is comfortably positioned. Gently rock the seat forward or rearward to be sure the seat is locked in place.

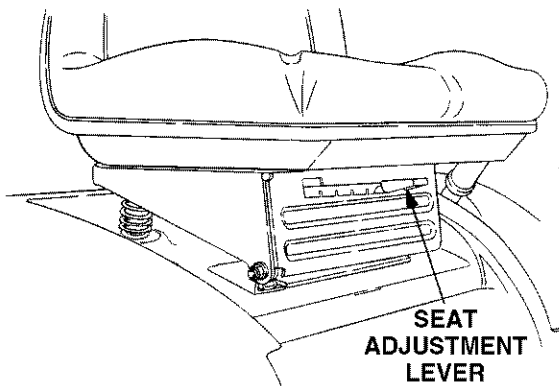

Figure 10

ADJUSTING THE BRAKES

During normal operation of this tractor, the brakes are subject to wear and will need periodic examination and adjustment.

To check the brake adjustment, position the tractor on a firm and level surface. Stop the tractor engine and remove the ignition key. Pull and lock the transmission release lever in the “TRANSMISSION RELEASED” position. Perform the following checks:

1. Engage the brake pedal lock. If the tractor can be pushed forward or rearward, the braking force must be increased.
2. Release the brake pedal lock. If the tractor cannot be pushed forward or rearward, the braking force must be decreased.

To adjust the braking force, refer to Figure 11 and proceed as follows:

1. Place the tractor on a level surface with the brake pedal lock disengaged. Stop the tractor engine and remove the ignition key.
2. While working from the underside of the tractor, facing the threaded end of the rod:
 - Remove the internal cotter pin from the brake rod adjustment ferrule and disconnect the ferrule from the brake cam.
 - Loosen the hex jam nut from against the ferrule.

To increase the braking force—

Turn the ferrule clockwise (inward) one full turn at a time until the ferrule can be inserted into the brake cam while applying a **minimal tension** on the spring.

To decrease the braking force—

Turn the ferrule counterclockwise (outward) one full turn at a time until the ferrule can be inserted into the brake cam while applying a **minimal tension** on the spring.

3. Turn the ferrule counterclockwise (outward) one full turn to release the slight spring tension. Tighten the jam nut against the ferrule, then insert the ferrule into the brake cam and secure with the internal cotter pin.

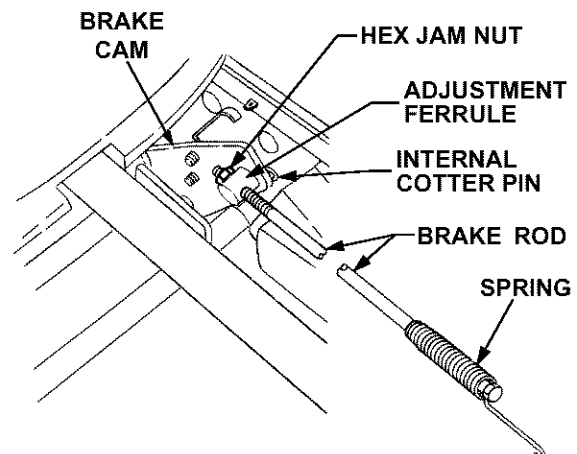

Figure 11. Viewed from top (fender off).

Recheck the brake adjustment to ensure proper brake operation before operating the tractor. If brake rod adjustment does not correct the problem, see your authorized *Cub Cadet* dealer.

WHEEL ALIGNMENT

The front wheels should toe-in approximately 1/8 to 1/4 inch, as measured across dimensions A and B shown in Figure 12.

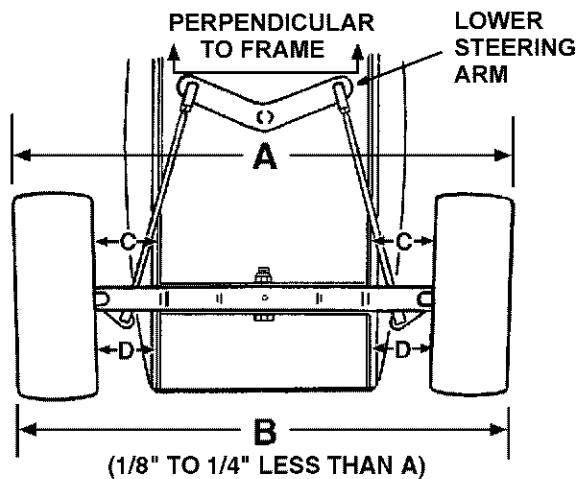

Figure 12. Viewed from beneath the tractor.

FRONT WHEEL ADJUSTMENT



WARNING

Place the tractor on a firm and level surface.

To adjust the toe-in, proceed as follows:

1. Check the lower steering arm to ensure it is perpendicular to the tractor frame (See Figure 12).
2. Place a mark at the same spot on both front wheels; preferably the inner bead flange of the wheel rims.
3. Rotate the wheels to position the marks at the front *horizontal* diameter of the wheels, then measure the distance between the marks and the bottom edges of the tractor frame channels (See measurement D in Figure 12). These two measurements should be equal.
4. While holding the steering arms to prevent the steering knuckles from moving, rotate the marks to the rear *horizontal* diameter. Measure the distance between the marks and the frame (See measurement C in Figure 12). Measurement D should be approximately 1/16 to 1/8 inch less than measurement C on each side of the tractor.

5. Disconnect the front ball joints from the steering arms by removing the hex lock nuts (Refer to Figure 13). Manually move each wheel to achieve the required toe-in *and* equal D measurements.
6. Loosen the jam nuts from the ball joints (See Figure 13).

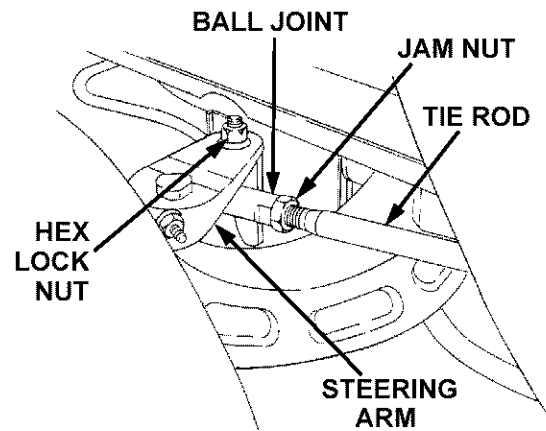

Figure 13

7. Making sure not to move the lower steering arm or either wheel, turn the ball joint in or out on each tie rod as necessary to align with the hole in each steering arm.
8. Reinstall the ball joints in the steering arms and secure with the hex lock nuts. Tighten the jam nuts against the ball joints.

PIVOT BAR ADJUSTMENT



CAUTION

The tractor should be checked every 50 hours of operation for play between the frame axle channel and the pivot axle.

Check and adjust the pivot axle as follows:

1. Raise the front of the tractor and set it on jack stands, so the front wheels are suspended above the ground.



CAUTION

For safety, block the rear wheels to prevent the tractor from rolling and tipping or sliding the jack stands.

- Pivot the ends of the axle up and down to check for binding. If the axle is binding, loosen the lock nuts (See Figure 14) until binding is eliminated.

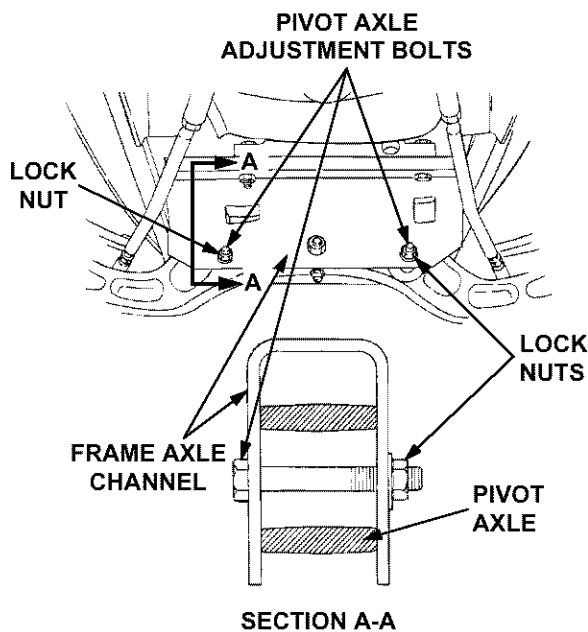

Figure 14

- Grasping the ends of the pivot axle, attempt to move each end of the axle forward and rearward to check for side play between the axle and frame channel. If play is present, gradually tighten the lock nuts until play is minimized.
- Repeat steps 2 and 3 until minimum play without binding is achieved.
- Raise the front of the tractor, remove the jack stands, and lower the tractor to the ground. Remove the blocks from the rear wheels.

HYDROSTATIC NEUTRAL ADJUSTMENT

The following adjustments will be necessary if the tractor creeps forward or rearward when neither the forward nor reverse pedals are depressed.

Checking the Transmission Neutral Setting

To check and adjust the transmission neutral setting, proceed as follows:

- Drive the tractor for approximately 5-10 minutes to warm up the transmission, then stop the engine and engage the parking brake.

WARNING

Place the tractor on a firm and level surface and chock the front wheels before raising the rear wheels from the ground. Use jack stands to support the rear of the tractor when raised.

- Raise the rear of the tractor, so that the rear tires are at least one inch above the surface, and set it on jack stands. Make certain the jack stands are positioned to balance the tractor and prevent tipping.

WARNING

The operator presence safety circuit will stop the engine if the seat is empty when the brake pedal is released. If an assistant is seated when adjusting the neutral setting, use extreme caution to prevent the tractor from tipping or rolling. Similar precautions should be taken with any other method of over-riding the safety circuit, such as placing a weight in the seat. Never operate the tractor with the safety circuit disabled.

- Carefully start the tractor engine and release the parking brake. Observe both rear wheels for rotation in either direction.
- If wheel rotation is observed, adjust the neutral setting as follows:
 - Disconnect the rear control rod from the control arm by removing the hairpin cotter from the pivot sleeve (Refer to Figure 15).
 - If wheel rotation stops when the rod is disconnected, check and readjust the control rod per the instructions below.
 - If wheel rotation continues, loosen the locknut securing the hex cap screw and centering spacer to the neutral bracket (See Figure 15).
 - If the rotation is in the *forward* direction, slide the centering spacer rearward until the wheels just begin to rotate in the *reverse* direction. Then slowly slide the spacer slightly forward until wheel rotation stops.
 - If the rotation is in the *reverse* direction, slowly slide the centering spacer slightly forward until rotation stops.
 - Carefully tighten the hex cap screw and locknut, making certain the centering spacer does not move.
 - Stop the engine and **engage the parking brake**.

1. Front Control Rod
2. Rear Control Rod
3. Hex Tap Screw
4. Pivot Sleeve
5. Neutral Arm
6. Control Arm
7. Hex Cap Screw
8. Centering Spacer
9. Neutral Bracket
10. Hairpin Cotter
(Not Shown)

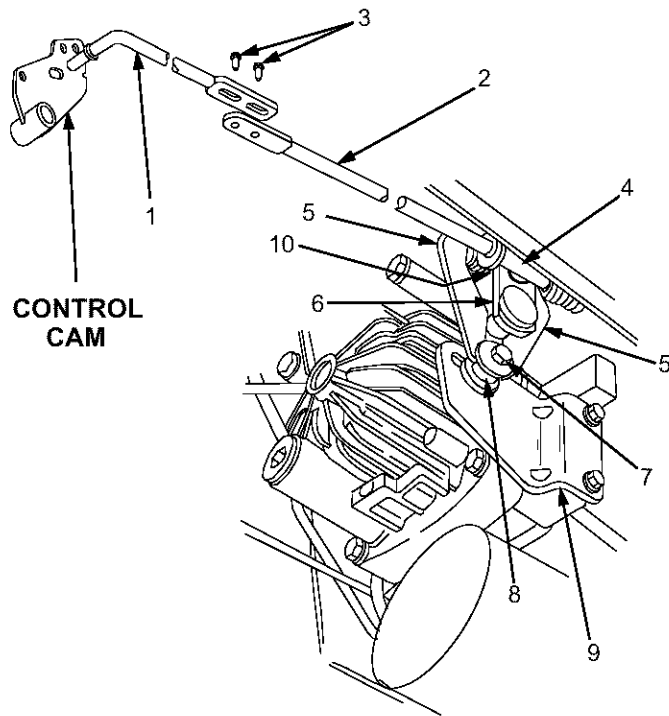

Figure 15.

Adjusting the Control Rod

After completing the previous steps (1 thru 4) for checking neutral setting, adjust the control rod (See Figure 15) as follows:

➔ NOTE

The brake pedal lock **MUST** be engaged to properly adjust the control rod.

1. Loosen, but do not remove, the hex tap screws that fasten the front and rear control rods together.
2. While making certain to not move the front control rod, control cam or control arm (See Figure 15), slide the rear control rod in the direction necessary to directly align the pin of the pivot sleeve with the lower hole of the control arm.
3. Insert the pivot sleeve pin into the control arm and secure with the hairpin cotter, then tighten the hex tap screws. Make sure to maintain the adjusted position of the control rods when tightening the screws.
4. Raise the rear of the tractor, remove the jack stands and lower the tractor.

ADJUSTING LIFT ASSIST SPRING TENSION

The effort required to operate the implement lift handle can be varied by loosening or tightening the lift assist spring adjusting bolt (See Figure 16). The bolt can be accessed from the rear of the tractor, inside the left rear wheel. Turning the adjusting bolt clockwise will decrease the manual effort required for lifting attachments; turning counterclockwise will increase the effort needed to lift the attachment.

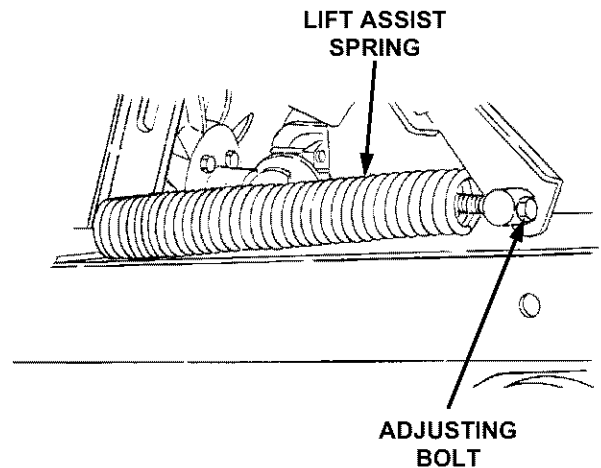

Figure 16

CARBURETOR ADJUSTMENTS



WARNING

When making adjustments to the carburetor while the engine is running, disengage the PTO clutch and engage the brake pedal lock. Keep clear of all moving parts and be careful of all hot surfaces. Carbon monoxide fumes can be fatal! Do not make any adjustments to the carburetor in a confined area such as a storage building. Move the tractor outside into the open air.

The carburetor on the engine is low emission. The high idle is set at the factory and cannot be adjusted. The carburetor is equipped with an idle speed adjustment screw, and an idle mixture valve that has an adjustment limiter which allows some adjustment.

If the engine does not operate properly and the problem appears to be fuel system related, check the following areas before adjusting the carburetor: Refer to **MAINTENANCE** section.

- Check for fuel in fuel tank
- Check fuel cap vent for blockage
- Check fuel line for pinched or obstructed areas
- Check for fuel filter blockage
- Check for a clogged air filter

If, however, the engine is hard-starting or runs roughly or stalls at low idle speed, it may be necessary to adjust or service the carburetor. Minor carburetor adjustment may also be needed to compensate for differences in fuel, temperature or altitude.

The air filter element and cover plate must be assembled to the carburetor when running the engine.



NOTE

Carburetor adjustments should be made only after the engine has warmed up.

Adjust the carburetor idle fuel mixture as follows:

1. Start the engine and warm up approximately 5 minutes before adjusting.

2. With the engine running, place the throttle control in the "SLOW" position.
3. Rotate the carburetor throttle lever against the idle speed screw and hold it (See Figure 17).
4. Turn the idle speed screw to obtain 1300 to 1500 RPM.
5. While still holding the carburetor throttle lever against the idle speed screw, turn the idle mixture valve screw (with limiter cap) midway between limits.

Readjust the idle speed to 1200 RPM. Release the carburetor throttle lever. Move the throttle control to the "FAST" position. The engine should accelerate smoothly. If it does not, readjust the idle mixture valve slightly counterclockwise. **DO NOT** remove the limiter cap. **DO NOT** force beyond the limit.

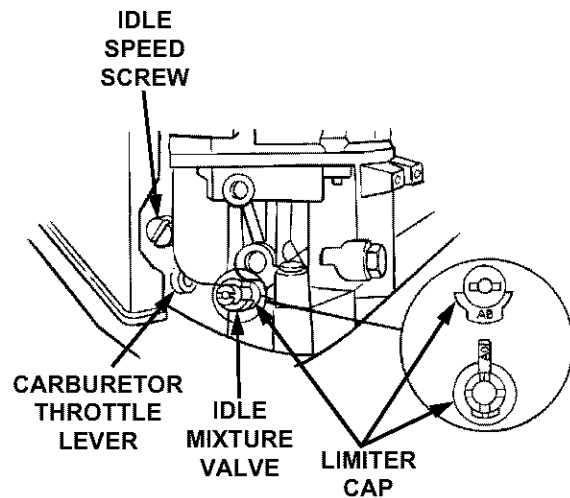

Figure 17



NOTE

Engines operated at approximately 3000 to 5000 feet (900 to 1500 meters) above sea level may require a high altitude carburetor main jet. If erratic performance is observed, contact your Authorized Engine Dealer for a high altitude main jet.

Control Adjustments

To adjust the choke control, remove the air cleaner. Move the choke control to the full choke position. The carburetor choke should be completely closed (See Figure 18). If not, loosen the casing clamp screw.

Move the casing, wire and engine choke lever in the direction shown until the choke is completely closed. Tighten the casing clamp screw and replace the air cleaner.

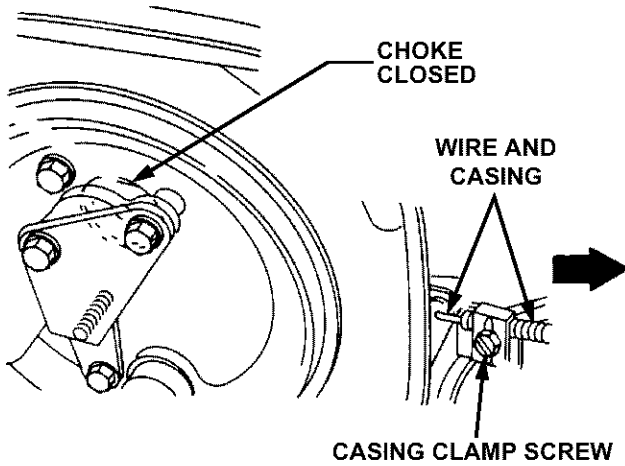

Figure 18

To adjust the throttle control, remove the air cleaner. Move the the throttle control to the "FAST" position. The swivel should be against the throttle stop (See Figure 19). If not, loosen the casing clamp screw. Move the casing and wire in the direction shown by the arrow until the swivel is against the throttle stop. Tighten the casing clamp screw and replace the air cleaner.

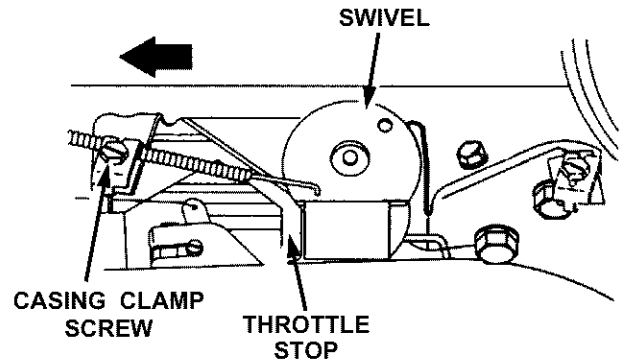

Figure 19

The adjustable governor control was set at the factory. If adjustment is required, consult your Authorized *Cub Cadet* Service Dealer.

SECTION IV. MAINTENANCE

ENGINE OIL

The engine oil must be drained and replaced with new oil after the first 5 to 8 hours of engine operation and then after every 50 hours of operation.

To aid starting, the selection of crankcase lubricating oils should be based on the lowest anticipated temperatures until the next scheduled oil change.

Use high quality detergent Engine Oil meeting API Service Classification SG, SH, SJ or higher.

For oil change intervals of 50 hours, use the following oil viscosity chart to determine the correct oil to use in the engine.

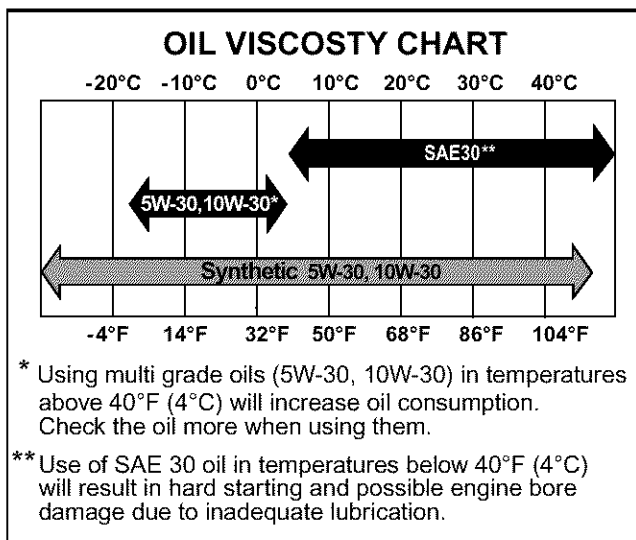

Regularly check the oil level of the engine crankcase to see that it is filled to the correct level. Always keep the oil level up to the "FULL" mark on the dipstick. When checking the oil level, the engine should be cold, the dipstick must be withdrawn and wiped clean, then pushed fully into the tube before being withdrawn for a true reading.

CHECKING THE OIL LEVEL

Before each use, the oil level of the engine crankcase should be checked to see that it is filled to the correct level. Close monitoring of the oil level during the first 10 hours of operation of the engine is especially important. Before checking the oil level, clean the area around the oil level dipstick to prevent debris from entering the crankcase. Always keep the oil level up to the "FULL" mark on the dipstick (See Figure 20). When checking the oil level, the engine must be cold, the dipstick must be withdrawn and wiped clean, then pushed fully into the tube before being withdrawn for a true reading.

NOTE

Check the oil level only while the engine is stopped and the tractor is level.

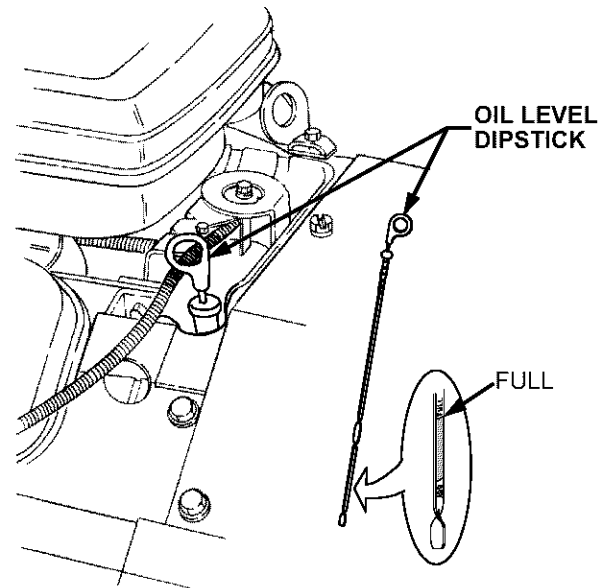

Figure 20



CAUTION

The dipstick must be inserted securely in the dipstick tube when the engine is operating. Severe engine damage could result from failure to do so.

ADDING OIL



CAUTION

Never overfill the engine crankcase. The engine may overheat and/or damage may result if the crankcase is below the "LOW" mark or over the "FULL" mark on the dipstick. For best results, fill to the "FULL" mark on the dipstick as opposed to adding a given quantity of oil. Always check the level on the dipstick before adding more oil.

Refer to the **LUBRICATION TABLE** for information regarding the proper type of oil to add to the crankcase.

1. Place the tractor on a level surface and engage the brake pedal lock. Stop the tractor engine and remove the ignition key.

- Clean the area around the oil filler cap to prevent debris from entering the crankcase. See Figure 21.

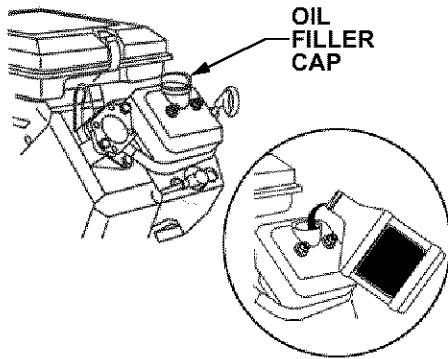

Figure 21

- Unscrew the oil filler cap from the right valve cover and **SLOWLY** pour in oil (See Figure 21). Fill the crankcase until the oil level reaches the “FULL” mark on the dipstick (Refer to Figure 20).
- Reinstall the oil filler cap by screwing it securely into the valve cover.



CAUTION

The oil filler cap **must be tightened securely into the valve cover at all times** when the engine is operating. Severe engine damage could result from failure to do so.

DRAINING OIL AND REPLACING OIL FILTER

The engine oil should be changed after the first 5 to 8 hours of operation. Then oil should be changed after every 50 hours of operation.



WARNING

If the tractor has recently been operated, the engine and surrounding areas may be hot. Use caution not to burn yourself when removing the side panels, draining the oil from the crankcase, and changing the oil filter.



NOTE

The oil filter should be changed at every oil change interval. The filters can be obtained through your *Cub Cadet* dealer under part number BS-492932.

Refer to the **MAINTENANCE CHART** and the **LUBRICATION TABLE** for information regarding the frequency of required oil changes and the quantity and type of oil needed.

The oil filter is located behind the left side panel and is mounted on the engine (See Figure 22).

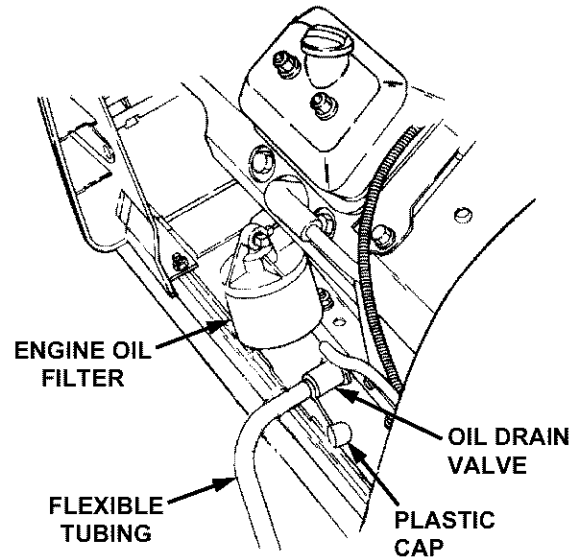

Figure 22

Run the engine for a few minutes to allow the oil in the crankcase to warm up. Warm oil will flow more freely and carry away more of the engine sediment which may have settled at the bottom of the crankcase. Use care to avoid burns from hot oil. While the engine oil is warm, proceed as follows:



NOTE

A 12 inch length of flexible tubing is supplied in the owner's manual package and should be used to drain the engine oil.

- Place the tractor on a level surface and engage the brake pedal lock. Stop the tractor engine and remove the ignition key.
- Clean around the base of the oil filter, the oil filler cap, and the dipstick tube to prevent debris from entering the crankcase.
- Unseat the plastic dust cap from the engine oil drain valve. To prevent loss of the cap, do not remove the cap's retaining ring from the drain valve (Refer to Figure 22). Remove the dipstick.
- Attach the flexible tubing (supplied in owner's manual package) to the drain valve. Place an appropriate container below the open end of the tubing to collect the old oil.

5. To open the drain valve, push it slightly inward and turn it counterclockwise until it stops, then pull it outward. Allow the old oil to completely drain from the engine crankcase into the container below.
6. Remove the filter by turning it counterclockwise using an automotive type filter wrench to loosen.
7. Push the drain valve inward, turn clockwise until it stops and then release it to close the valve.
8. Remove the flexible tubing from the drain valve. Clean the tubing and store in a safe place for future use.
9. Clean the drain valve and push the plastic dust cap onto the valve.
10. Apply a light coating of clean oil on the gasket of the new oil filter. Thread the filter on by hand until the gasket contacts the oil filter adapter, then tighten the filter an additional 1/2 to 3/4 turn.

Refer to **FILLING THE CRANKCASE** and to the **LUBRICATION TABLE** then refill the crankcase with the quantity and type of oil specified.

FILLING THE CRANKCASE



Never overfill the engine crankcase. The engine may overheat and/or damage may result if the crankcase is below the "LOW" mark or over the "FULL" mark on the dipstick. For best results, fill to the "FULL" mark on the dipstick as opposed to adding a given quantity of oil. Always check the level on the dipstick before adding more oil.

Refer to the **LUBRICATION TABLE** for information regarding the oil capacity and the proper type of oil to pour into the crankcase.

1. Place the tractor on a level surface and engage the brake pedal lock. Stop the tractor engine and remove the ignition key.
2. Clean the area around the oil filler cap and the dipstick to prevent debris from entering the crankcase.
3. Remove the oil filler cap from the valve cover and **SLOWLY** pour in oil. The oil capacity is approximately 1-1/2 quarts. Fill the crankcase until the oil level reaches the "FULL" mark on the dipstick (Refer to Figure 20).

4. Securely screw the oil filler cap into the valve cover and the dipstick into the tube.



The oil fill cap and dipstick **must be tightened securely when the engine is operating**. Severe engine damage could result from failure to do so.

5. Start the tractor engine and allow it to run for 30 seconds, then stop the engine and remove the ignition key.
6. Check the oil level and add oil if necessary. **do not overfill the engine crankcase**.
7. Check the oil filter and drain valve for leaks.

CHECKING TRANSMISSION OIL LEVEL



Check the oil level only while the engine is stopped and the tractor is level.

Check the oil level of the transmission case before each use to see that it is filled to the correct level. Before checking the transmission oil level, clean the area around the oil fill plug/dipstick to prevent debris from entering the transmission case. Always keep the oil level between the "FULL" and the "ADD" marks on the dipstick (See Figure 23). When checking the oil level, the dipstick must be withdrawn and wiped clean, then inserted all the way before being withdrawn for a true reading.

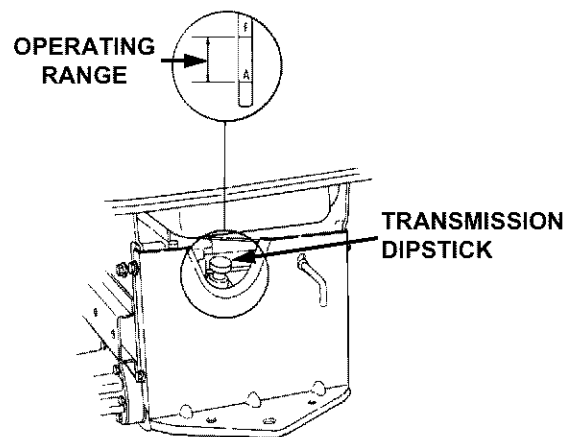

Figure 23

ADDING TRANSMISSION OIL



CAUTION

Never overfill the transmission case. Damage or leakage may result if the oil level in the transmission case is below the "ADD" mark or over the "FULL" mark of the dipstick. For best results, fill to the "FULL" mark on the dipstick as opposed to adding a given quantity of oil. Always check the level on the dipstick before adding more oil.

Refer to the **LUBRICATION TABLE** for information regarding the proper type of oil to add to the transmission case.

1. Place the tractor on a level surface and engage the brake pedal lock. Stop the tractor engine and remove the ignition key.
2. Clean the area around the oil fill plug/dipstick to prevent debris from entering the transmission case.
3. Remove the oil fill plug/dipstick from the oil fill port and SLOWLY pour oil into the oil fill port. Fill the transmission case until the oil level reaches the "FULL" mark on the dipstick (Refer to Figure 23).
4. Reinstall the oil fill plug/dipstick securely into the oil fill port.



CAUTION

The oil fill plug/dipstick **must be installed securely into the fill port at all times when the engine is operating.**

HYDROSTATIC DRIVE OIL FILTER



CAUTION

Never overfill the transmission case. Damage or leakage may result if the oil level in the transmission case is below the "ADD" mark or over the "FULL" mark of the dipstick. For best results, fill to the "FULL" mark on the dipstick as opposed to adding a given quantity of oil. Always check the level on the dipstick before adding more oil.

Refer to the **MAINTENANCE CHART** for information regarding the frequency of the hydrostatic transmission oil filter replacement. The filter can be obtained through your *Cub Cadet* dealer under the part number 923-3014.

Refer to the **LUBRICATION TABLE** for information regarding the oil capacity and the proper type of oil to pour into the transmission case.

1. Place the tractor on a level surface and engage the brake pedal lock. Stop the tractor engine and remove the ignition key.
2. Clean the area around the transmission drain plug to prevent debris from entering the transmission case. Remove the drain plug and allow the transmission oil to drain into a clean container having a capacity of more than 7 quarts. Reinstall the drain plug (Refer to Figure 24).

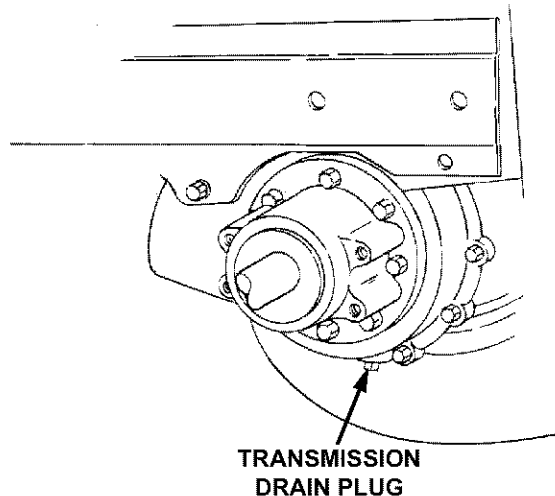

Figure 24



CAUTION

If the transmission oil is to be re-used, cover the container holding the drained oil to prevent contamination. Contaminated transmission oil can damage the hydro transmission.

3. Clean around the base of the transmission oil filter and remove the filter by turning it counterclockwise (Refer to Figure 25).

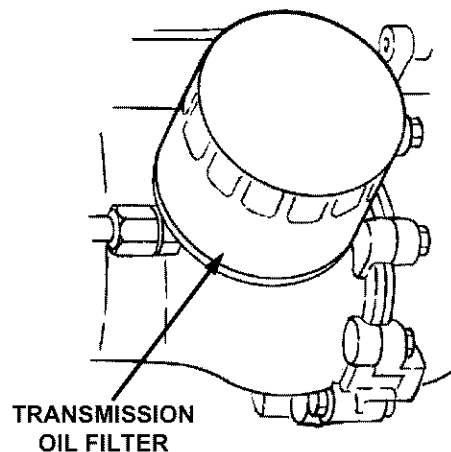

Figure 25

4. Apply a light coating of clean transmission oil to the gasket of the new filter. Install the filter by turning it clockwise, by hand, until the gasket contacts the filter base on the transmission housing; then tighten the filter an additional 1/2 turn.
5. Clean the area around the transmission oil fill plug/dipstick to prevent debris from entering the transmission case.
6. Remove the oil fill plug/dipstick from the oil fill port and SLOWLY pour oil into the oil fill port. Fill the transmission case until the oil level reaches the "FULL" mark on the dipstick (Refer to Figure 22).
7. Reinstall the oil fill plug/dipstick securely into the oil fill port.
8. Start the engine and allow it to run for a few minutes. Shut the engine off, then check for leaks and re-check the oil level in the transmission case.



CAUTION

The oil fill plug/dipstick **must be installed securely into the fill port at all times when the engine is operating.**

AIR CLEANER

Check the air cleaner daily or before starting the engine. Check for loose or damaged components and check the condition of the filter element. Remove any buildup of dirt and debris in the air cleaner housing.



NOTE

Operating the engine with loose or damaged air cleaner components will allow unfiltered air into the carburetor, causing extensive wear and eventual failure of the engine.

Servicing the Precleaner

Wash the foam precleaner after every 25 hours of operation (more often under extremely dusty or dirty conditions).

1. Unhook the clips on both sides of the air cleaner cover and remove the air cleaner cover (See Figure 26).
2. Remove the foam precleaner by sliding it up off the paper element (See Figure 26).
3. Wash the precleaner in warm water with detergent. Rinse the precleaner thoroughly until all traces of the detergent are eliminated. Squeeze out (do not wring) excess water in a dry cloth. Allow the precleaner to air dry.

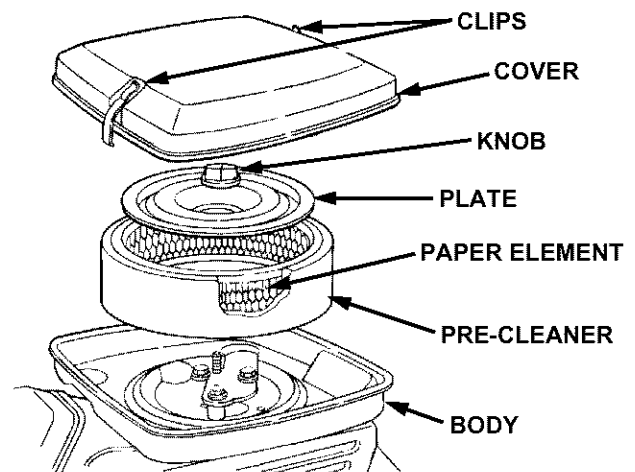

Figure 26. Air Cleaner Assembly.

4. Reinstall the foam precleaner over the paper element.
5. Reinstall the air cleaner cover and reattach the cover clips to both sides of the air cleaner body.

Servicing the Paper Element

Every 100 hours of operation (more often under extremely dusty or dirty conditions), inspect the paper element. Replace the element as necessary.

1. Unhook the clips on both sides of the air cleaner cover and remove the air cleaner cover (See Figure 26).
2. Remove the foam precleaner by sliding it up off the paper element (See Figure 26).
3. Remove the knob and element cover plate, then carefully lift out the paper air filter element to prevent debris from entering the carburetor.
4. Do not wash the paper element or use pressurized air, as this will damage the element. Replace a dirty, bent or damaged element. Handle new elements carefully; do not use if the sealing surfaces are bent or damaged.
5. When servicing the air cleaner, check the air cleaner body. Make sure it is secured and not bent or damaged. Also check the element cover plate for damage or improper fit. Replace all damaged air cleaner components.
6. Reinstall the paper element, foam precleaner, cover plate and knob. Reinstall the air cleaner cover and reattach the cover clips to both sides of the air cleaner body.

Properly cleaned and installed air cleaner elements significantly contribute to prolonging engine life.

CLEANING ENGINE

This tractor has an air-cooled engine. Air must be able to circulate freely around the engine through the flywheel screen, through the cooling shrouds and over the fins of the cylinder head and cylinder block (See Figure 27). Keep these areas free of accumulated dirt and debris to keep the engine from overheating and possibly causing extensive engine damage. Regularly clean the inside of the side panels, dash intake screen and grille to ensure adequate cooling. If debris has accumulated inside the cooling shrouds, the blower housing and cooling shrouds should be removed and the cooling fins cleaned.

NOTE

This machine is designed to cool properly with the side panels in place. Operating without the panels could cause premature accumulation of dirt and debris on the engine, resulting in inadequate cooling.

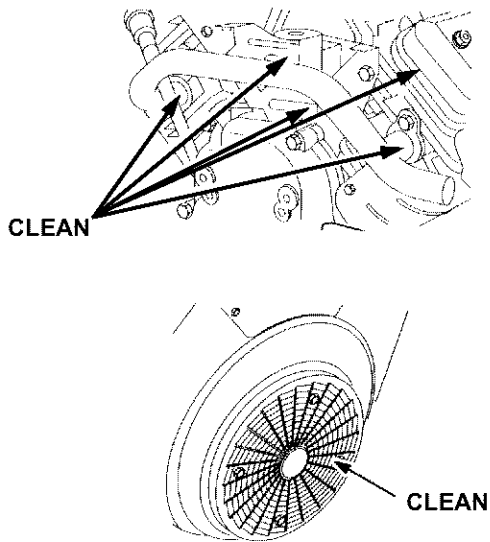

Figure 27

To assure smooth operation, keep the governor linkage, springs and controls free of debris (See Figure 28).

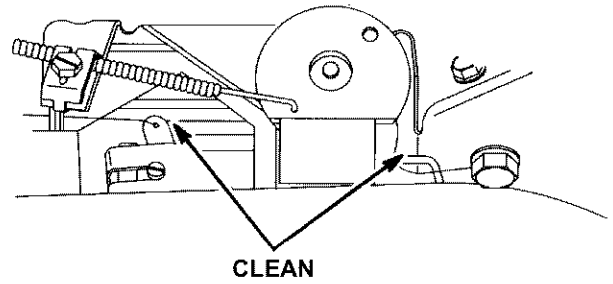

Figure 28



CAUTION

Keep the muffler area clean. Before running the engine, clean the muffler area to remove all combustible debris. Inspect the muffler area often when mowing during the Fall season

SPARK PLUG



WARNING

To avoid possible injury, be sure the engine is off and has cooled before making any adjustments or repairs.



NOTE

Remove all dirt from around the spark plug before removing. Always use a spark plug wrench to remove the spark plugs

Check the spark plug gap and clean the plug yearly. Replace a worn plug with a new plug. Set the spark plug gap at .030 inch (See Figure 29). Tighten the plug to 10-15 ft-lbs. See your authorized dealer for the correct replacement plug.

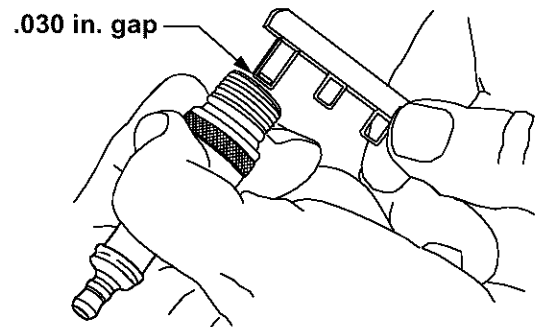

Figure 29

FUEL FILTER



WARNING

Do not replace the fuel filter when engine is hot.

The engine is equipped with an inline fuel filter. Visually inspect the filter periodically for a build-up of residue inside the filter body, and for a dirty element which can be indicated by discoloration. Replace the fuel filter when dirty.

HEADLIGHTS

Refer to **SPECIFICATIONS** when replacement of a headlight bulb is necessary.



WARNING

Allow the engine and surrounding surfaces to cool before changing the headlight bulbs.

Replace headlight bulbs as follows: (See Figure 30)

1. Unplug the wire harness leads from the headlight socket terminals. *Note which wire connects to each terminal before disconnecting.*
2. Rotate the socket assembly as follows to remove from the reflector housing:
 - Left headlight — approximately 1/4 turn counterclockwise.
 - Right headlight — approximately 1/4 turn clockwise.
3. Push the bulb inward and turn counterclockwise to remove from the socket.

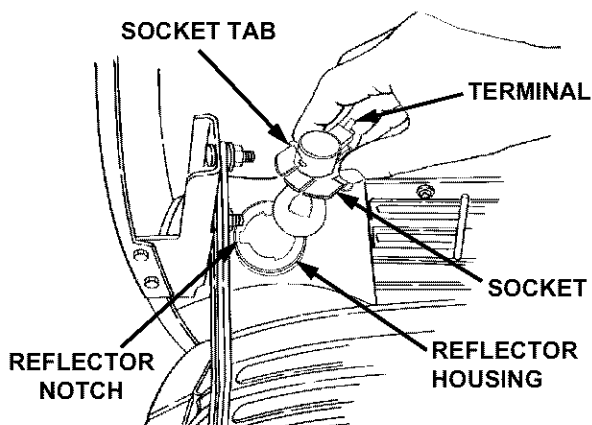

Figure 30

4. Align a locking post of the bulb base with the notch in the socket, then push the bulb inward and turn clockwise to lock

5. With the terminals pointing upward, align the tab of the socket with the notch of the reflector. Push the socket inward and turn as follows to lock:
 - Left headlight — approximately 1/4 turn clockwise.
 - Right headlight — approximately 1/4 turn counterclockwise.
6. Connect the wire harness leads to the appropriate socket terminals.

FUSES

Always use the same capacity fuse for replacement. Refer to **SPECIFICATIONS**. If the electrical system does not function, check the fuses.

To replace a fuse, pull the old fuse from the fuse holder and install the new fuse.

GENERAL BATTERY INFORMATION



WARNING

- a. Battery posts, terminals and related accessories contain lead and lead compounds. **Wash Hands after handling.**
- b. Should battery acid accidentally splatter into the eyes or onto the skin, rinse the affected area immediately with clean cold water. If there is any further discomfort, seek prompt medical attention.
- c. If acid spills on clothing, first dilute it with clean water, then neutralize with a solution of ammonia/water or baking soda/water.
- d. NEVER connect (or disconnect) battery charger clips to the battery while the charger is turned on, as it can cause sparks.
- e. Keep all sources of ignition (cigarettes, matches, lighters) away from the battery. The hydrogen gas generated during charging can be combustible.
- f. As a further precaution, only charge the battery in a well ventilated area.

ALWAYS SHIELD EYES AND PROTECT SKIN AND CLOTHING WHEN WORKING NEAR BATTERIES.



DANGER

Batteries contain sulfuric acid and may emit explosive gases. use extreme caution when handling batteries. Keep batteries out of the reach of children.

MAINTENANCE OF BATTERY

The tractor is shipped with a wet battery — the battery acid has already been added and the battery sealed. Although the battery is maintenance free, the following care should be taken when handling the battery and to assure its proper life cycle.

1. Spray the terminals and exposed wire with a battery terminal sealer, or coat the terminals with a thin coat of grease or petroleum jelly, to protect against corrosion.
2. Always keep the battery cables and terminals clean and free of corrosion.
3. Always keep the terminal covers in place over the battery terminals.
4. Avoid tipping. Even a sealed battery will leak electrolyte when tipped.

STORAGE OF THE BATTERY

1. When storing the tractor for extended periods, disconnect the negative battery cable. It is not necessary to remove the battery.
2. All batteries discharge during storage. Keep the exterior of the battery clean, especially the top. A dirty battery will discharge more rapidly.
3. The battery must be stored with a full charge. A discharged battery can freeze sooner than a charged battery. A fully charged battery will store longer in cold temperatures than hot.
4. Recharge the battery before returning to service. Although the tractor may start, the engine charging system may not fully recharge the battery.

COMMON CAUSES FOR BATTERY FAILURE

1. Overcharging
2. Undercharging
3. Loose and/or corroded connections
4. Excessive loads
5. Freezing of electrolyte

* These causes do not constitute warranty in the event of a battery failure.

BATTERY REMOVAL OR INSTALLATION



WARNING

Battery posts, terminals and related accessories contain lead and lead compounds. **Wash Hands after handling.**

When removing the battery, disconnect the battery cables in the following order to avoid arcing and the resulting sparks:

Battery Removal:

1. Disconnect the Negative cable.
2. Disconnect the Positive cable.

Battery Installation:

1. Connect the Positive cable.
2. Connect the Negative cable.

To replace the battery, proceed as follows:

1. Remove the negative cable from the negative terminal of the battery, then remove the positive cable from the positive terminal.
2. Remove the wing nut securing the LH mounting rod to the mounting tab on the left side of the bulkhead (See Figure 31). Pull the rod downward from the bulkhead tab.

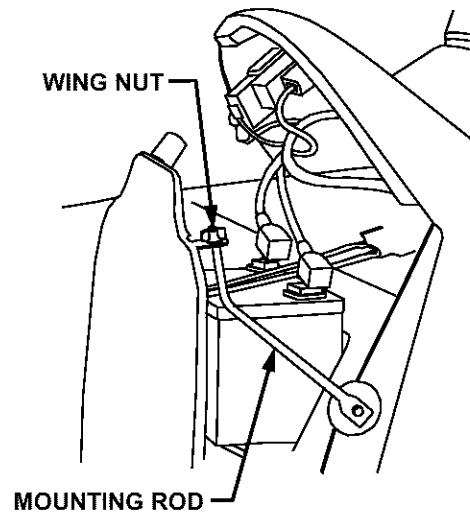

Figure 31

3. Rotate the mounting rod fully upward toward the dash panel to provide clearance for battery removal (See Figure 32).

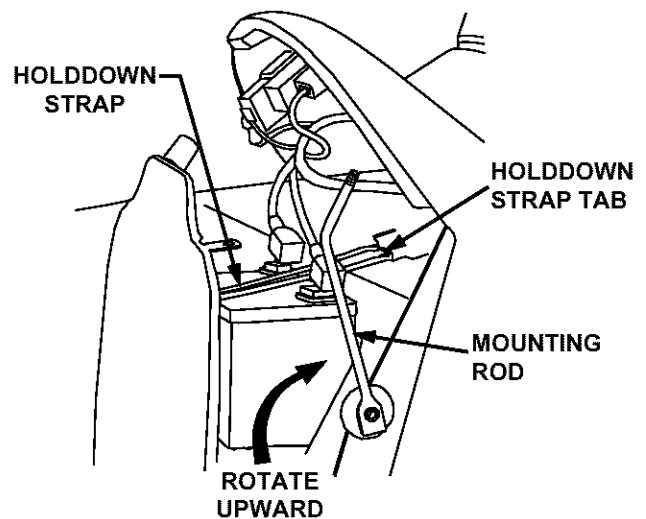

Figure 32

4. Pull downward on the bottom of the battery holddown strap to release it from the tab beneath the battery tray.

5. Loosen the hose clamp and pull the drain tube from the battery.
6. Lift the battery upward and remove from the left side of the tractor.
7. Install the new battery from the left side of the tractor and lower into the battery tray.
8. Install the drain tube onto the battery and secure with the hose clamp.
9. After making sure the holddown is securely looped around the tab on top of the pedestal, stretch the battery holddown strap downward across the front of the battery and loop around the tab below the battery tray.
10. Rotate the mounting rod downward and insert through the bottom of the hole in the bulkhead mounting tab (Refer to Figure 31).
11. Install the wing nut onto the mounting rod, but do not tighten until after the side panels are installed.
12. Connect the positive cable to the positive terminal of the battery, then connect the negative cable to the negative terminal.

CHARGING THE BATTERY

Test and, if necessary, recharge the battery after the tractor has been stored for a period of time.

- A voltmeter or load tester should read 12.6 volts (DC) or higher across the battery terminals.
- Charge the battery with a 12-volt battery charger at a **MAXIMUM** rate of 10 amps.

Voltmeter Reading	State of Charge	Charging Time
12.7	100%	Full Charge
12.4	75%	90 Min.
12.2	50%	180 Min.
12.0	25%	280 Min.

JUMP STARTING



WARNING

Failure to use this jump starting procedure could cause sparking, which could result in an explosion of either battery.

1. Attach the first jumper cable from the positive terminal of the good battery to the positive terminal of the dead battery.

2. Attach the second jumper cable from the negative terminal of the good battery to the **FRAME OF THE UNIT WITH THE DEAD BATTERY.**

TIRES

Keep the pneumatic tires properly inflated. Over-inflation will cause operator discomfort. Under-inflation will cause short tire life.

Improperly inflated tires will also affect the leveling of the mower deck and quality of cut.

Inflate the front and rear tires as shown in the following table:

Tire Size	Pounds per Square Inch
Front Tires 15 x 6-6	14
Rear Tires 20 x 9-8	10

Always ensure that the tire valve caps are in place and tightened securely to prevent loss of air and to protect the valve core and stem.

Do not overload the tractor tires by mounting equipment on the tractor which exceeds the load capacity of the size of the tires on the tractor.

MOUNTING TIRES ON THE RIM



WARNING

Do not mount a tire unless you have the proper equipment. Do not inflate the tire above the recommended pressure. Do not stand over the tire assembly when inflating. Accidental over inflation could cause an explosive separation of the tire and rim, which could result in serious injury or death.

After mounting a new or old tire on the rim, inflate it to 20 pounds (maximum) pressure to seat the tire bead on the rim flange. Then deflate the tire to the correct operating pressure.



NOTE

After the first 10 hours of operation, check and retorque the rear wheel lug nuts (both sides) to 35 ft-lbs to make sure they are seated in the rim and are properly tightened.

SECTION V. MOWER DECK

This section contains adjustment, removal, installation, and maintenance information for the 42-inch mower deck. Instructions for installation and removal of the optional mulching plug are located at the end of this section.

A. DECK LEVELING ADJUSTMENTS

In order to achieve even cutting, the mower deck must be properly leveled. This leveling procedure will result in the left and right blades having corresponding front cutting-edge-to-ground measurements within 1/16 inch of each other. Also, the right and the left blades will each have a 1/8 to 1/4 inch downward tilt toward the front of the tractor. To level the mower deck, proceed as follows:



WARNING

Before making any adjustments, place the PTO switch in the "OFF" position, engage the brake pedal lock, turn the ignition key to the "OFF" position, remove the key from the switch and remove the spark plug wire to avoid accidental starting and injury.



WARNING

When adjusting the mower deck, be careful not to cut yourself on the sharp blades.



NOTE

If the mower deck is not level, the mower will not cut your lawn evenly.



NOTE

Check the tires for proper inflation before making a leveling adjustment. To level the deck, the tractor and deck **MUST** be placed on a hard, level surface during adjustment.

SIDE-TO-SIDE LEVELING ADJUSTMENT

1. Position the tractor and mower deck on a hard, level surface.
2. Open the tractor hood and disconnect the spark plug wire.
3. The mower deck front and rear gauge wheels should be installed in their uppermost position in the deck brackets to prevent contact with the hard, level surface below. Refer to **GAUGE WHEEL ADJUSTMENT**.
4. Raise the tractor implement lift handle to its highest setting.
5. Position the mower blades so that the ends of each blade face the right and left sides of the tractor (See Figure 33).

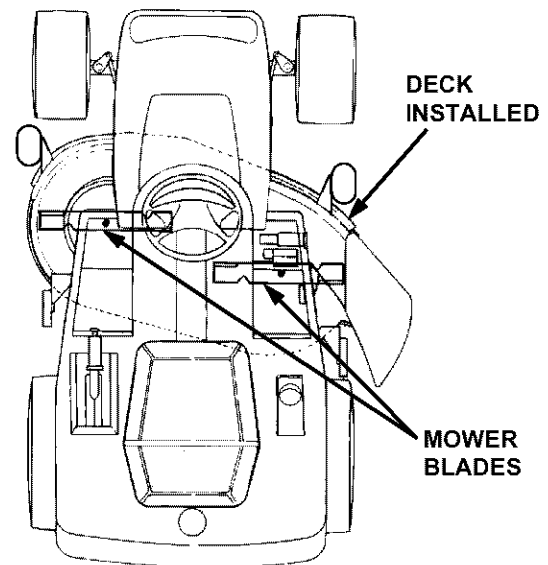
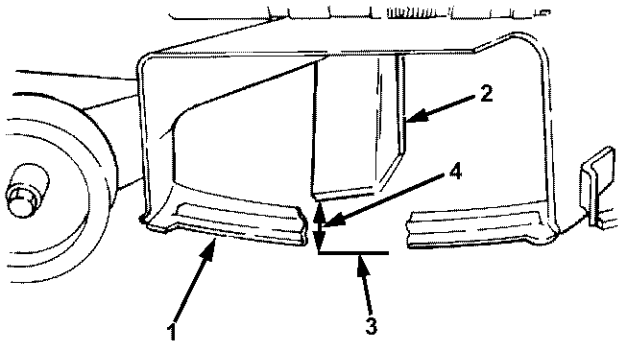

Figure 33

6. Referring to Figure 34, measure and record the distance from the hard, level surface to the outermost cutting edge of the right blade. Repeat this step for the left blade. If the two blade heights are not within 1/16 inch, proceed to steps 7, 8 and 9. If the two blade heights are within 1/16 inch, proceed to **FRONT TO BACK LEVELING ADJUSTMENT**.



1. Finger guard
2. Blade
3. Hard Level Surface
4. Measure This Distance

Figure 34

7. Lower the deck onto the hard, level surface.
8. Side-to-side leveling is obtained utilizing the adjustment ferrule and right hand hanger bracket (See Figure 35).

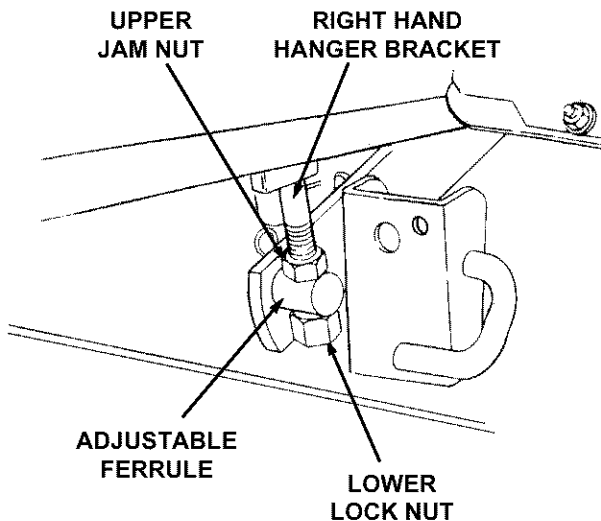

Figure 35

9. Loosen the upper jam nut on the hanger bracket and turn away from the adjustment ferrule. Turn the lower lock nut upward (tighten) on the threads of the hanger bracket to raise the right side of the mower deck. Turn the lock nut down (loosen) on the threads to lower the right side of the mower deck (Refer to Figure 35).
10. Raise the lift handle to the highest position and recheck the blade measurements described in step 6. If the blade measurements are not within 1/16 inch, repeat steps 7, 8 and 9.
11. Tighten the upper jam nut against the adjustment ferrule after side-to-side leveling is completed.

FRONT TO BACK LEVELING ADJUSTMENT

1. Raise the deck to its highest position.
2. Position the mower blades so the ends of each blade point to the front and the rear of the tractor (See Figure 36).

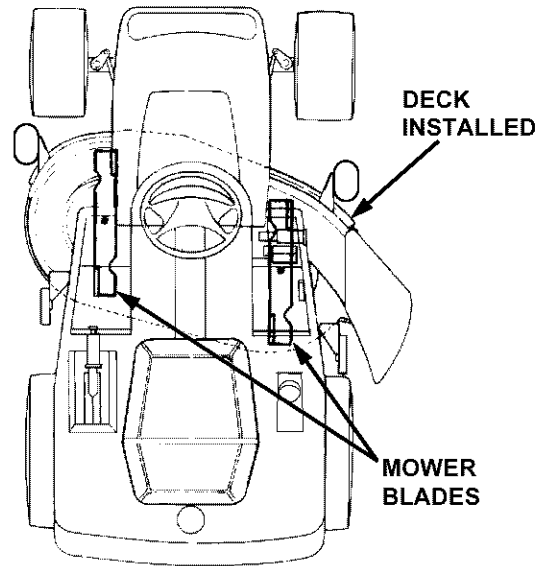

Figure 36

- Initially adjust the front lift rod to allow 5/8 inch of thread to protrude beyond both lock nuts of the front lift rod/bracket assembly (Refer to Figure 37).

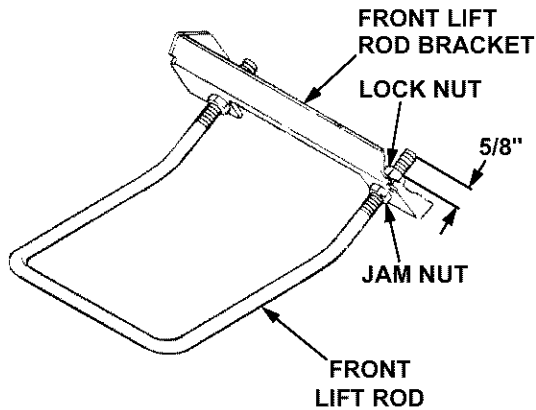

Figure 37

- Refer to Figure 38. Measure and record the distance from the front cutting edge to the ground (measurement A), and from the rear cutting edge to the ground (measurement B), for each of the blades. The front edge of each blade (measurement A) should be lower than its back edge (measurement B) by 1/8 to 1/4 inch.
- Lower the deck onto the hard, level surface.
- To adjust the downward tilt of the blades, adjustment of the front lift rod is required. Refer to Figure 37 and proceed as follows:
 - Loosen the rear jam nuts on the front lift rod. From the front of the tractor, turn the front lock nuts clockwise to raise the front of the mower deck, or counter-clockwise to lower the front of the mower deck.
- Raise the deck to the highest position. Recheck the blade measurements described in step 4. If the resultant measurements are not correct, repeat steps 5, 6 and 7 until the proper measurements are obtained.

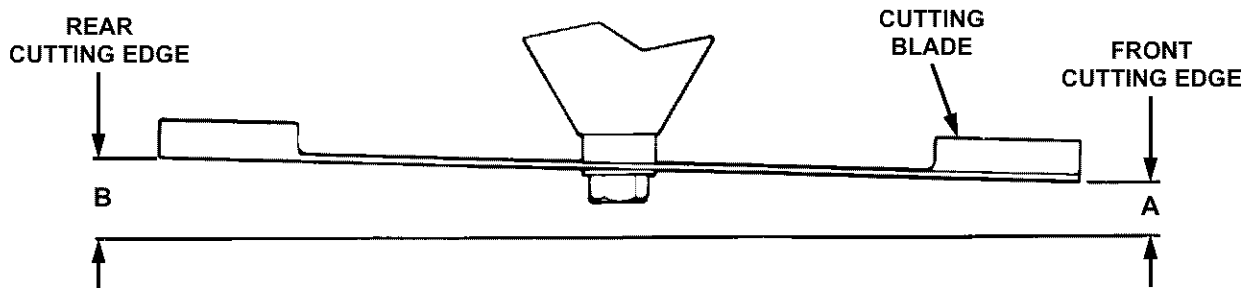

Figure 38

NOTE

The front lift rod must be against the back of both slots in the deck front roller bracket. If one side of the rod is not against the back of the slot after attaining the correct front pitch to the deck, tighten the front lock nut on that side until the rod just contacts the back of the slot.

- Tighten the rear jam nuts after adjustment is completed.
- Connect the spark plug wire.

GAUGE WHEEL ADJUSTMENT

WARNING

Before making any adjustments, place the PTO switch in the "OFF" position, engage the brake pedal lock, turn the ignition key to the "OFF" position, remove the key from the switch and remove the spark plug wire to avoid accidental starting and injury.

WARNING

When adjusting the mower deck, be careful not to cut yourself on the sharp blades.

NOTE

Gauge wheel adjustment should be performed only AFTER the mower deck has been properly leveled.

NOTE

Gauge wheels are intended to prevent scalping of the lawn, and are not meant to be used to set the cutting height. Do not run the deck on the gauge wheels.

To adjust the height of the gauge wheels, place the tractor on a firm and level surface. Refer to Figure 39, and proceed as follows:

1. Place the tractor implement lift handle in the normally desired mowing height setting, then check the gauge wheels for contact or excessive clearance with the surface below.
2. If the wheels contact the surface adjust as follows:
 - a. Raise the implement lift handle to its highest setting.
 - b. Remove the rear gauge wheels by removing the lock nuts, shoulder screws, and flat washers. Remove the lock nuts, shoulder screws, and bell washers fastening the front ball wheels to the deck gauge wheel brackets.
 - c. Again place the tractor implement lift handle in the normally desired mowing height setting.

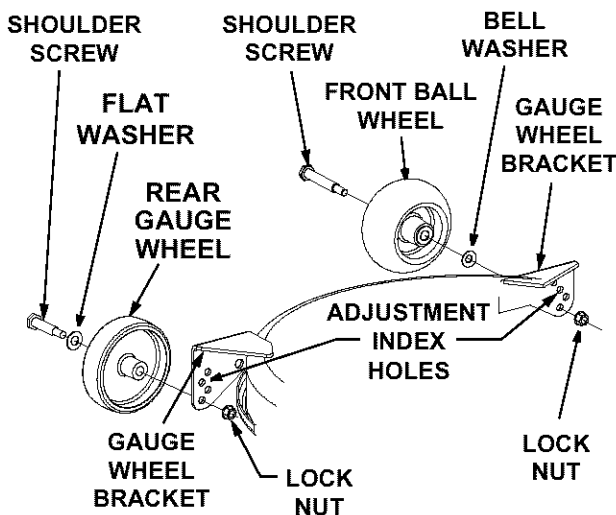

Figure 39

- d. Insert the shoulder screw and flat washer with the rear gauge wheel into the adjustment index hole that provides approximately 1/2"

clearance between the wheel and level surface. Secure with the lock nut.

- e. Note the position of the index hole used; then install the other rear gauge wheel and the front ball wheels into the corresponding index hole of the other gauge wheel brackets.

NOTE

The crowned (rounded) surface of the front ball washers should be against the shoulder of the shoulder screw, between the front ball wheel and deck gauge wheel bracket.

3. If the gauge wheels have excessive clearance with the surface below, lower the wheels to the index hole that provides the approximate 1/2" clearance as described above.

NOTE

All gauge wheels should be installed in the same relative adjustment index hole location in each of the gauge wheel brackets.

CUTTING HEIGHT ADJUSTMENT

The mower can be set in multiple positions. Proceed as follows:

NOTE

If multiple positions are used while mowing, it may be necessary to adjust the gauge wheels for each setting to prevent scalping.

1. Pull the tractor implement lift handle up slightly and depress the button on the top of the lift handle.
2. Raise or lower the lift handle to obtain the desired mower deck cutting height.
3. Release the button when the desired mower position is obtained.

NOTE

To return the mower deck to a specific position, note the position of the lift lever indicator before raising or lowering the mower deck.

B. REMOVAL AND INSTALLATION OF DECK ASSEMBLY

REMOVAL OF DECK



WARNING

Before removing the mower deck, place the PTO switch in the "OFF" position, engage the brake pedal lock, turn the ignition key to the "OFF" position and remove the key from the switch. Disconnect the spark plug wire for additional safety.

1. Position the tractor and mower deck on a firm, level surface.



WARNING

When handling the mower deck, be careful not to cut yourself on the sharp blades. The deck idler arm lever is spring loaded. Release it slowly.

2. Lower the tractor implement lift handle to its lowest setting (adjust gauge wheels if necessary). Disengage the deck idler arm lever from its stop bracket and release the spring tension by rotating the lever out and rearward (See Figure 40).

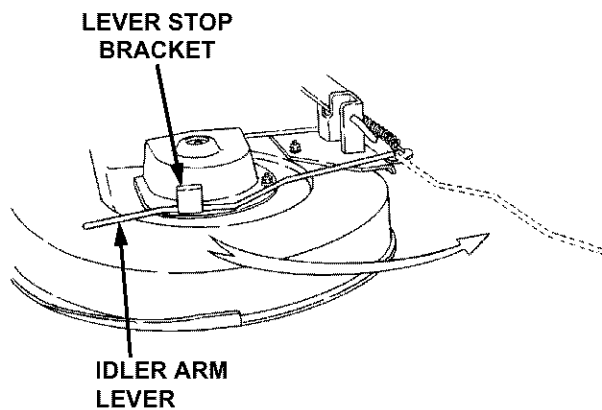

Figure 40

3. Remove the rearward end of the PTO belt from the upper pulley of the deck center double-pulley (Refer to Figure 41). Engage the deck idler arm lever back into its stop bracket (Refer to Figure 42).

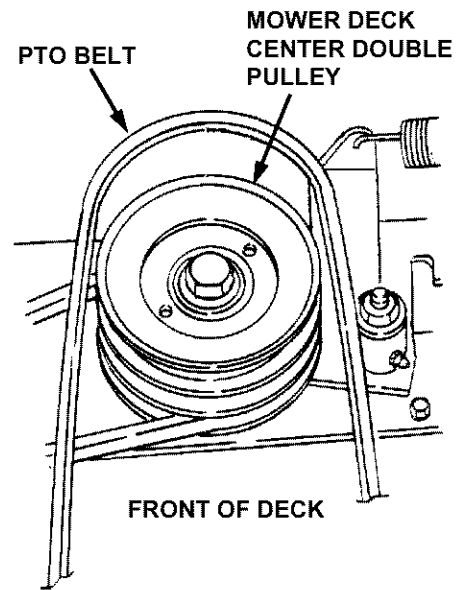

Figure 41

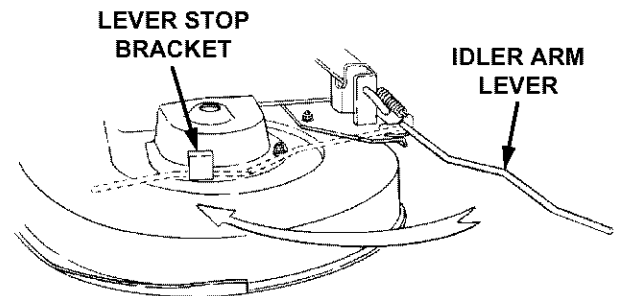

Figure 42

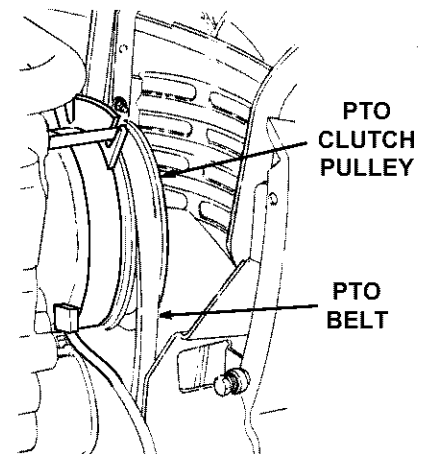

Figure 43



WARNING

The exhaust system is **HOT**. To avoid personal injury, allow the engine and exhaust system to cool before proceeding with the following PTO belt removal instructions.

4. Open the tractor hood and remove the forward end of the PTO belt from the PTO clutch pulley on the front of the engine (Refer to Figure 43).
5. Pass the PTO belt downward, inside the tractor frame, until the belt is below the two tractor front lower pulleys and pull the belt clear of the tractor (See Figure 44).

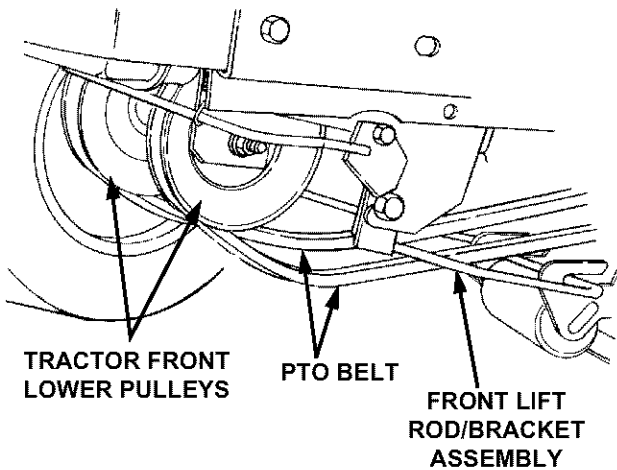

Figure 44

6. Pull the deck support pins outward, turn downward and release so both spring-loaded pins are held in the disengaged position against the outer surface of the deck brackets (See Figure 45).

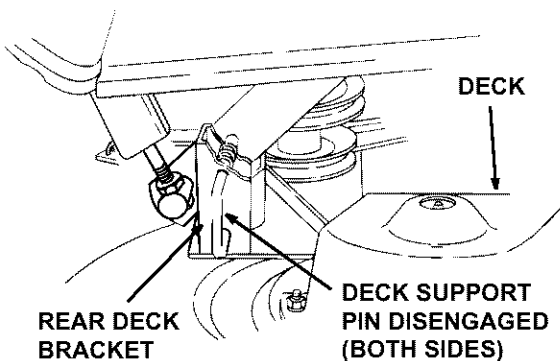

Figure 45

7. Raise the tractor implement lift handle to its highest setting, Slide the mower deck forward, so the front lift rod rests to the rear of, and free of, the front roller bracket slots of the deck (See Figure 46).

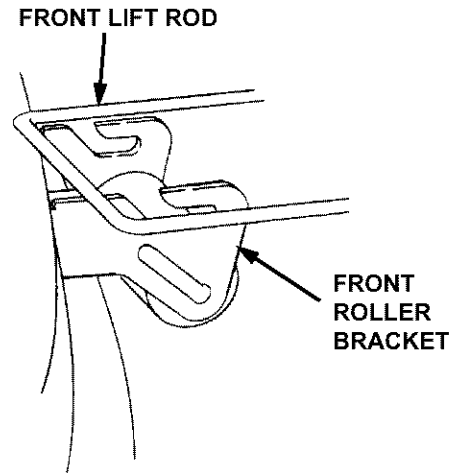

Figure 46

8. Raise the front lift rod upward and slide the mower deck rearward. Lower the front lift rod so it rests on the front roller bracket of the deck, forward of the slots (See Figure 47).

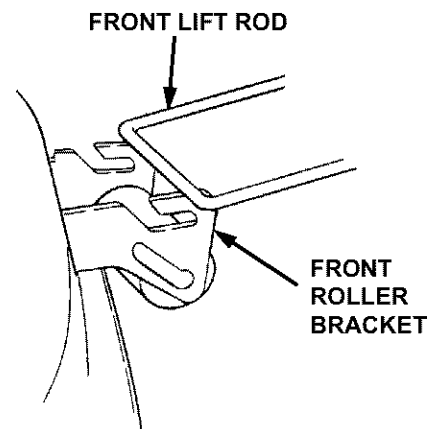

Figure 47

9. From the front of the tractor, push downward and hold the tractor quick-attach rod. Pull the front lift rod/bracket assembly forward to release the shoulder bolts on each side of the bracket from the left and right tractor latch receivers. Release the tractor quick-attach rod (Refer to Figure 48).

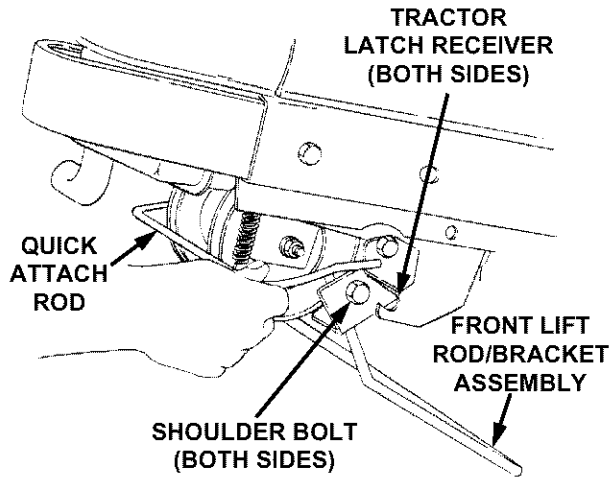

Figure 48

CAUTION

To avoid possible equipment damage, make sure that the tractor implement lift handle is raised to its highest setting before sliding the deck out from under the tractor.

10. With the tractor implement lift handle raised to its highest setting, slide the deck to the right and out from under the tractor (See Figure 49).

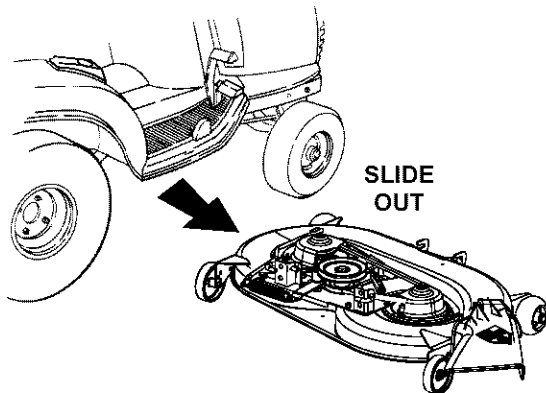

Figure 49

11. Connect the spark plug wire.

INSTALLATION OF DECK

WARNING

Before performing the mower deck installation, place the PTO switch in the "OFF" position, engage the brake pedal lock, turn the ignition key to the "OFF" position and remove the key from the switch. Disconnect the spark plug wire for additional safety.

WARNING

When handling the mower deck, be careful not to cut yourself on the sharp blades.

1. Position the tractor and mower deck on a firm, level surface.

CAUTION

To avoid possible equipment damage, make sure that the tractor implement lift handle is raised to its highest setting before sliding the deck under the tractor.

2. Refer to Figure 50 and position the deck on the right side of the tractor with the front of the deck facing toward the front of the tractor. Raise the tractor implement lift handle to its highest setting and slide the deck under the tractor.

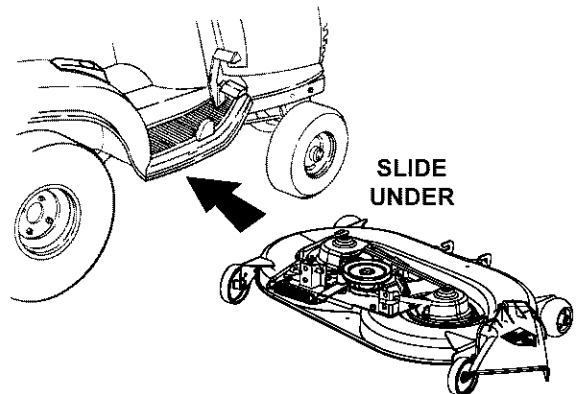

Figure 50

3. Make sure the slot in both rear deck brackets aligns with the implement lift links on each side of the tractor (See Figure 51).

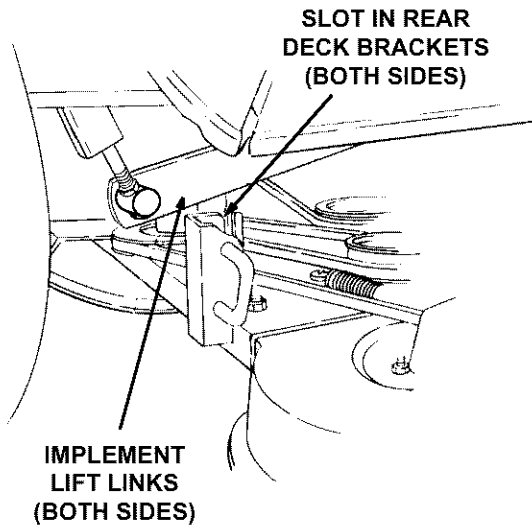

Figure 51

4. Refer to Figure 52 to ensure the correct orientation of the front lift rod/bracket assembly [form (bend) in sides of rod point downward]. From the front of the tractor, push downward and hold the tractor quick-attach rod. Slide the shoulder bolts on each side of the front lift rod/bracket assembly fully into the left and right tractor latch receivers. Release the tractor quick-attach rod to capture the front lift rod/bracket assembly in the tractor latch receivers (Refer to Figure 53).

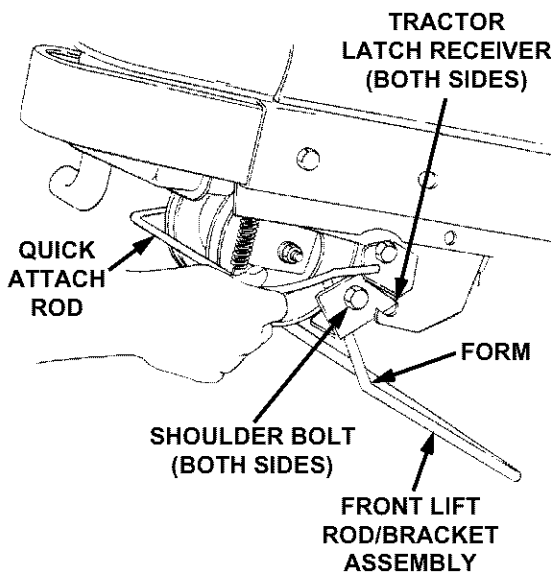

Figure 52

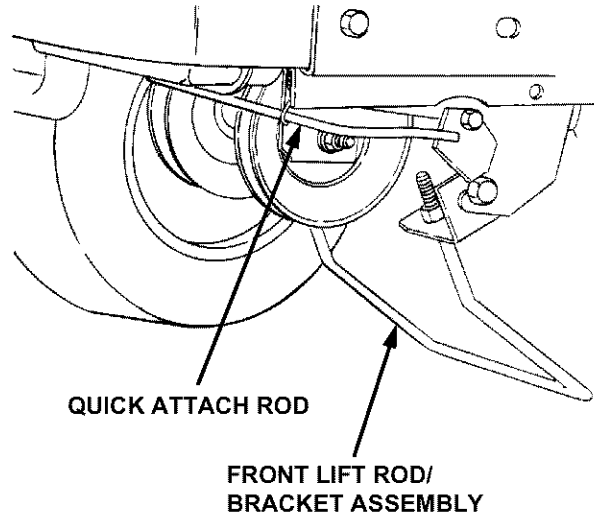

Figure 53

5. While holding the front lift rod up, slide the mower deck forward until the rod aligns with both front roller bracket slots. Lower the lift rod into the front roller bracket slots and slide the deck rearward to engage the lift rod fully forward in the slots of the deck front roller bracket (See Figure 54).

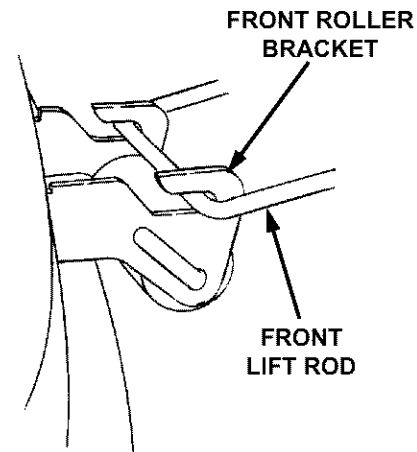

Figure 54

6. If not already done, pull the deck support pins outward, turn downward and release so both spring-loaded pins are held in the disengaged position against the outer surface of the deck brackets (Refer to Figure 55).

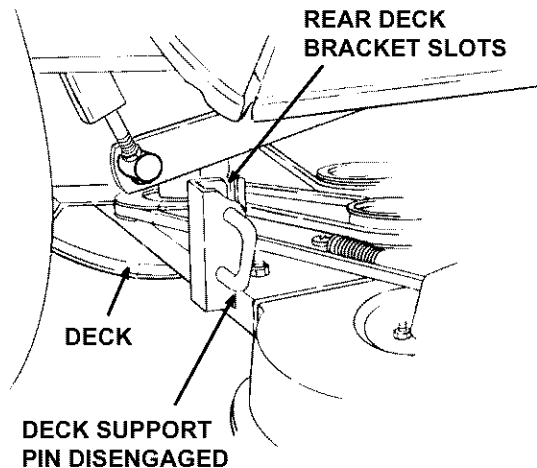

Figure 55

7. Carefully guide the tractor implement lift links (left and right) into the rear deck bracket slots (left and right) as the tractor implement lift handle is lowered to its lowest setting (Refer to Figure 56).
8. Pull both deck support pins outward and rotate rearward to disengage the outer surface of the rear deck brackets. Release the pins, making certain each deck support pin passes through the inner hole of the rear deck bracket. The spring tension will push the pins inward and, if aligned, through the hole in each implement lift link (See Figure 56).

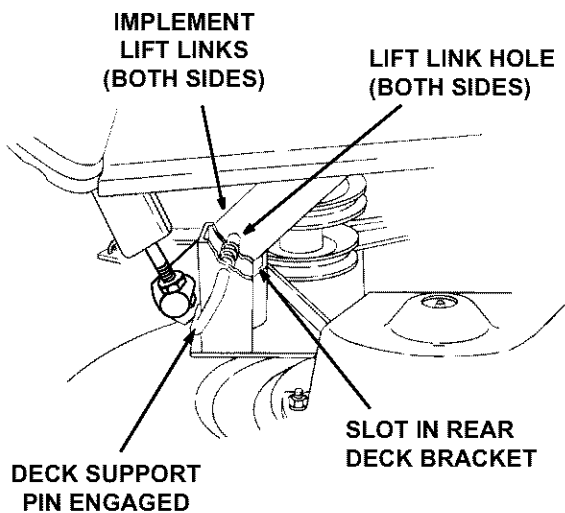

Figure 56

NOTE

It may be necessary to lift each side of the deck and maneuver it slightly to align the support pins with the holes of the lift links. Make certain the support pins are fully extended through the lift links to prevent the mower deck from disengaging the lift links while mowing.

WARNING

The deck idler arm lever is spring loaded. Release it slowly.

9. Disengage the deck idler arm lever from its stop bracket and release the spring tension by rotating the lever out and rearward (See Figure 57).

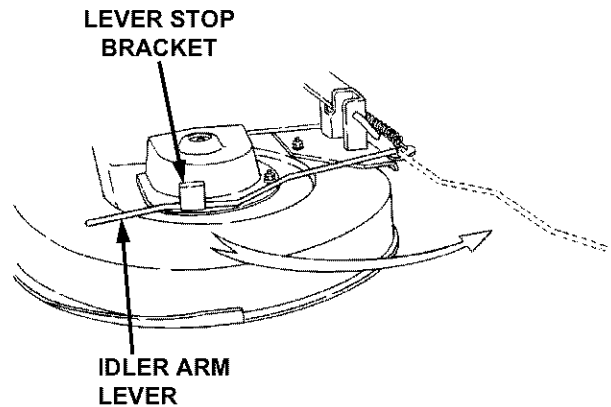

Figure 57

WARNING

The exhaust system is **HOT**. To avoid personal injury, allow the engine and exhaust system to cool before proceeding with the following PTO belt installation instructions.

10. Open the tractor hood and install the forward end of the PTO belt onto the PTO clutch pulley on the front of the engine. Ensure that the narrow side of the PTO belt engages the groove of the pulley (Refer to Figure 58).

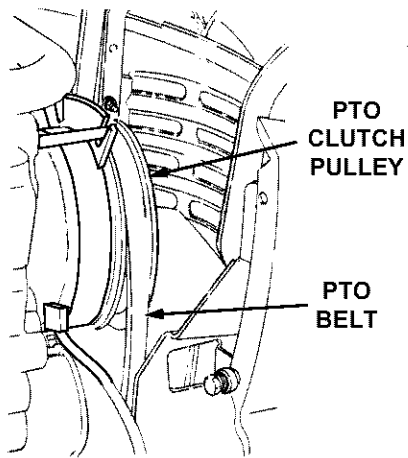

Figure 58

11. Pass the PTO belt downward, inside the tractor frame, until the belt is below the two tractor front lower pulleys. Twist the two sides of the PTO belt 1/4 turn inward to engage the narrow sides of the belt into the grooves of the two tractor front-lower pulleys (See Figure 59).

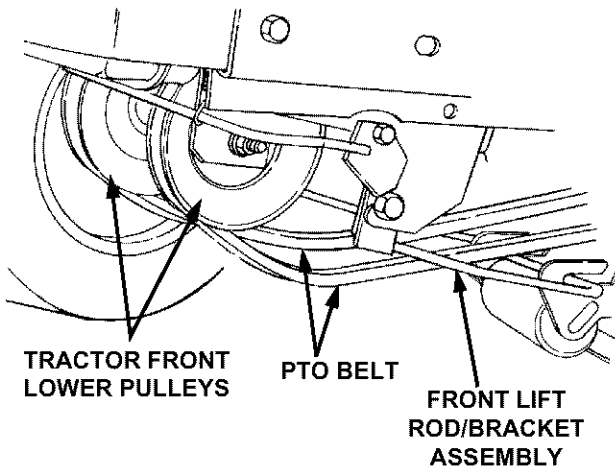

Figure 59

12. From the front of the tractor, push the PTO belt through the front lift rod, then to the center of the deck. Ensure that the forward end of the belt remains positioned inside the front lower pulleys.
13. Install the rearward end of the PTO belt on the upper pulley of the deck center double-pulley (Refer to Figure 60). Ensure that the narrow side of the belt engages the groove of the upper pulley.

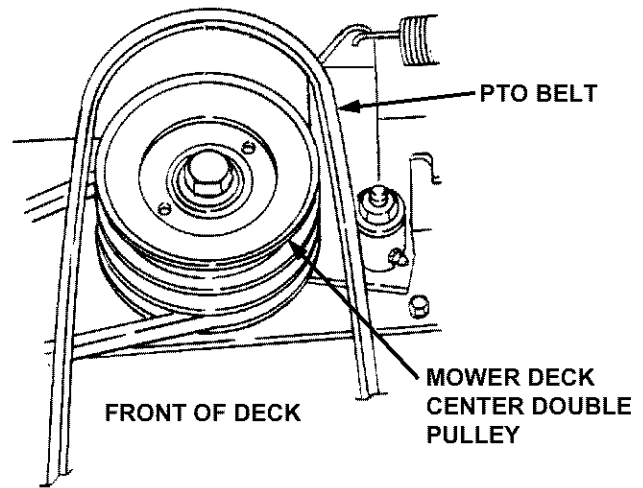

Figure 60

14. While holding the belt in position, rotate and engage the deck idler arm lever into its stop bracket to provide tension on the PTO belt (See Figure 61).

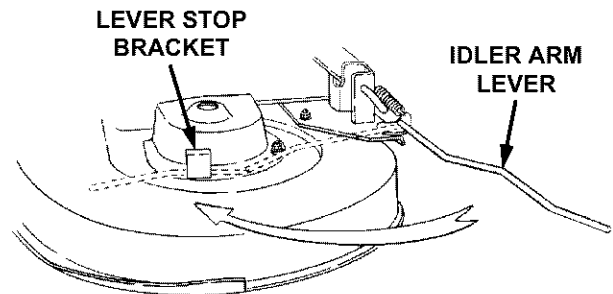

Figure 61

15. Connect the spark plug wire.

C. MAINTENANCE

CLEANING AND BLADE CARE



WARNING

Before performing any maintenance, place the PTO switch in the "OFF" position, engage the brake pedal lock, turn the ignition key to the "OFF" position and remove the key from the switch to avoid accidental starting and injury.



WARNING

When servicing the mower deck, be careful not to cut yourself on the sharpened blades.

Clean the underside of the mower deck at the end of the mowing season or when buildup of cut material on the underside is noticed. Also remove the belt covers and remove any accumulated grass clippings.

If using the mulching option, clean the underside of the deck frequently. A buildup of grass clippings will prevent proper mulching.

The cutting blades must be kept sharp at all times.



NOTE

Sharpen the cutting and mulching edges of the blades evenly so that the blades remain balanced and the same angle of sharpness is maintained. If the cutting edge of a blade has been sharpened to within 5/8 inch of the wind wing radius (See Figure 62), it is recommended that new blades be installed. New blades are available at your authorized dealer.

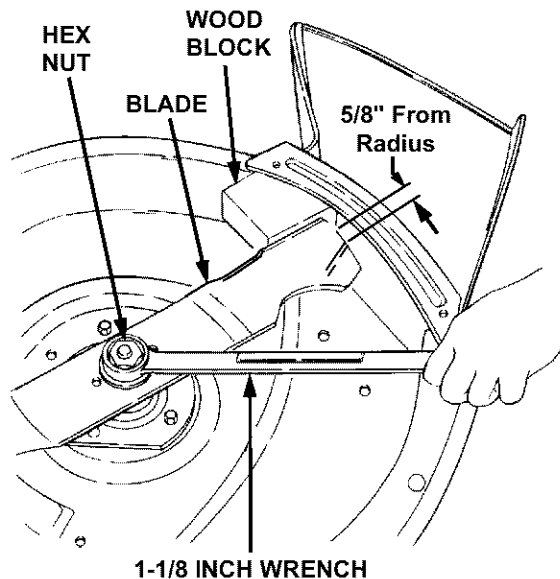

Figure 62

When removing the blades, use a 1-1/8 inch wrench to hold the hex head of the spindle bolt when loosening the hex nut securing the blade. A block of wood may be placed between the deck housing and the cutting edge of the blade to assist in removal of the hex nut securing the blade (Refer to Figure 62).

After replacing the blades, apply grease to the exposed threads at the bottom of the spindle bolts to prevent rust buildup.

When replacing the blades, be sure they are installed so that the wind wings are pointing upward toward the top of the deck housing. Tighten the nuts to 90 to 110 ft-lbs. (122 to 149 N-m).

LUBRICATION

NOTE: We do not recommend the use of a pressure washer or garden hose to clean your unit. They may cause damage to electrical components; spindles; pulleys; bearings; or the engine. The use of water will result in shortened life and reduce serviceability.

After every 10 hours of operation and/or before putting the deck into winter storage, lubricate the spindle assemblies and the spindle belt idler arm with 251H EP grease or an equivalent No. 2 multipurpose lithium grease. Excess grease will be expelled from the inverted upper seals of the spindle assemblies. Listen for the muffled crackling noise of grease being expelled through the seal to indicate the spindle assembly is fully greased. Refer to Figure 63.

Every 50 hours, or twice yearly, lubricate the double pulley with 251H EP grease or an equivalent No. 2 multipurpose lithium grease. Do not over lubricate. Refer to Figure 63.

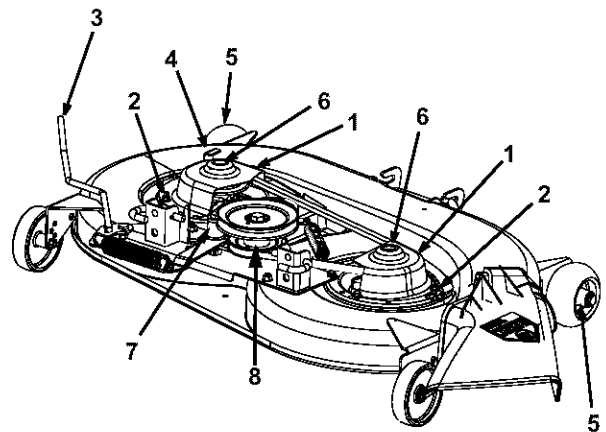

- | | |
|-----------------------|-------------------------------------|
| 1. Spindle Belt Cover | 6. Spindle Assembly Grease Fittings |
| 2. Flange Lock Nuts | 7. Idler Arm Grease Fitting |
| 3. Idler Arm Lever | 8. Double Pulley |
| 4. Stop Bracket | |
| 5. Front Ball Wheels | |

Figure 63

SPINDLE DRIVE BELT REPLACEMENT

In order to replace the spindle drive belt, refer to Figure 63 and Figure 64 and proceed as follows:

1. Remove the hardware that secures the spindle belt covers to the deck.
2. Remove the spindle belt covers to expose the belt.
3. Disengage the idler arm lever from its stop bracket and rotate the lever to the outside of the deck to release the spring tension.
4. Pull the flat idler pulley away from the backside of the belt and remove the old drive belt.
5. Install a new belt around the spindle pulleys and bottom pulley of the center double pulley; then position the flat idler pulley against the backside of the belt so that the belt is tensioned. Refer to Figure 64 for the proper routing of the belt.
6. Reinstall the spindle belt covers.
7. Engage the idler arm lever into its stop bracket.

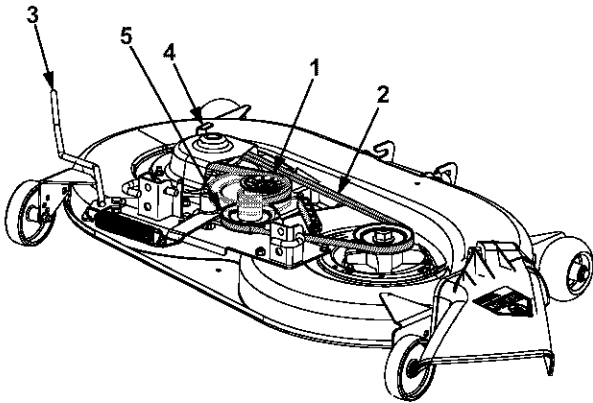

- | | |
|-----------------------|-------------------------|
| 1. Idler Pulley | 4. Stop Bracket |
| 2. Spindle Drive Belt | 5. Center Double Pulley |
| 3. Idler Arm Lever | |

Figure 64

D. INSTALLATION OF MULCHING PLUG



WARNING

Before installing the mulching plug, place the PTO switch in the "OFF" position, engage the brake pedal lock, turn the ignition key to the "OFF" position and remove the key from the switch to avoid accidental starting and injury.

1. If the mower deck has been used, clean any buildup of grass clippings from the discharge opening of the deck.
2. Lift the chute deflector upward and insert the mulching plug into the discharge opening of the deck (Refer to Figure 65).
3. Position the mulching plug so that its top hole aligns with the hole in the top of the deck housing. Install the carriage bolt through both surfaces and secure with the wing nut (See Figure 65).
4. To remove the mulching plug; remove the wing nut and carriage bolt, then withdraw the plug from the discharge opening. Insert the carriage bolt through the mulching plug and install the wing nut onto the bolt to prevent their loss.

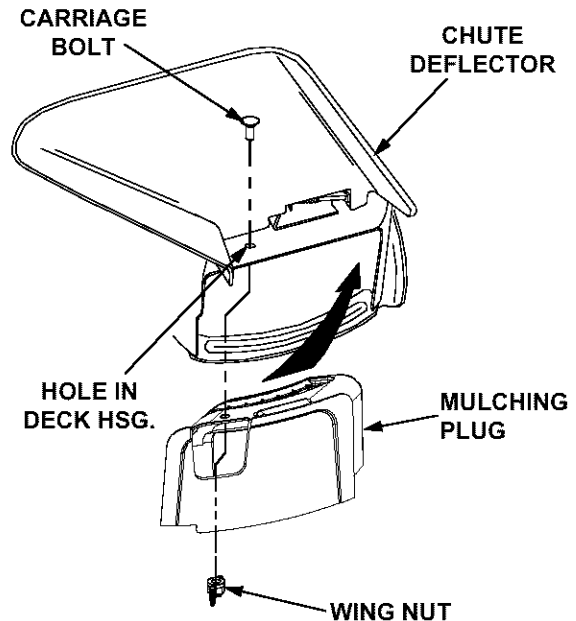

Figure 65

SECTION VI. OFF-SEASON STORAGE

If the machine is to be inoperative for a period longer than 30 days, the following procedures are recommended:



WARNING

Never store the tractor with fuel in the tank indoors or in poorly ventilated enclosures, where fuel fumes may reach an open flame, spark or pilot light as on a furnace, water heater, clothes dryer, etc.



CAUTION

Fuel left in the fuel tank during warm weather deteriorates and will cause serious starting problems.

To prevent gum deposits from forming inside the engine's carburetor and causing possible malfunction of the engine, the fuel system must be either completely emptied, or the gasoline must be treated with a stabilizer to prevent deterioration.

1. If using a fuel stabilizer:
 - a. Read the product manufacturer's instructions and recommendations.
 - b. Add to clean, fresh gasoline the correct amount of stabilizer for the capacity of the fuel system.
 - c. Fill the fuel tank with treated fuel and run the engine for 2-3 minutes to get stabilized fuel into the carburetor.

2. If emptying the fuel system:



WARNING

Do not drain fuel when the engine is hot. Allow the engine adequate time to cool. Drain fuel into an approved container outdoors, away from open flame.

- a. Drain any large volume of fuel from the tank by disconnecting the fuel line from the in-line fuel filter near the engine.
 - b. Reconnect the fuel line and run the engine until it starts to falter, then use the choke to keep the engine running until all fuel in the carburetor has been exhausted.
 - c. Again disconnect the fuel line and drain any remaining gasoline from the system.
3. Remove the spark plug and pour one (1) ounce of engine oil through the spark plug hole into the cylinder. Crank the engine several times to distribute the oil. Replace the spark plug.
 4. Clean the engine and the entire tractor thoroughly.

NOTE: *We do not recommend the use of a pressure washer or garden hose to clean your unit. They may cause damage to electrical components; spindles; pulleys; bearings; or the engine. The use of water will result in shortened life and reduce serviceability.*

5. Lubricate all lubrication points.
6. Follow the battery storage instructions on page 31.
7. Protect the tires and seat from sunlight. Regularly check the tires to maintain proper inflation.

SECTION VII. MOWING

MOWING



WARNING

To avoid possible injury, do not allow anyone in the area opposite the discharge chute while mowing. Although the area has been supposedly cleared of foreign objects, small objects may be picked up and discharged by the mower.



WARNING

Never direct the discharge of material toward bystanders or allow anyone near the machine while in operation.

For best results it is recommended that the first two laps should be cut with the discharge thrown towards the center. After the first two laps, reverse the direction to throw the discharge to the outside for the balance of cutting. This will give a better appearance to the lawn.

Do not cut the grass too short, as the mower will tend to scalp the grass. Short grass invites weed growth and yellows quickly in dry weather.

Mowing should be done with the engine at full throttle. Do not mow at high ground speed.

During certain times of the year and under some conditions, the mower may leave streaks of uncut grass.

Streaking may occur when attempting to mow heavy weeds and tall grass. Under these conditions it may be necessary to go back over the cut area a second time to get a clean cut.

The following practices will help eliminate streaking:

1. Mow the area more often so the grass doesn't get too tall and heavy.
2. Operate the tractor at full throttle and slower forward speeds.
3. Keep the blades sharp and replace the blades when worn.
4. Follow the mowing pattern shown in Figure 66.

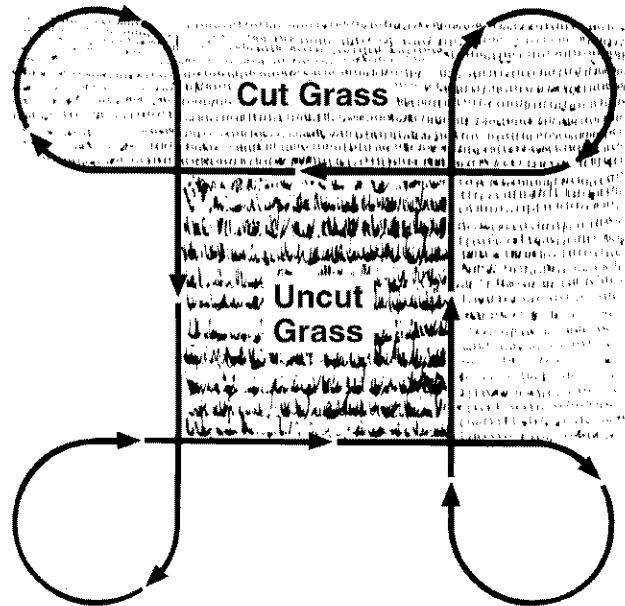

Figure 66

MOWING WITH MULCHING OPTION

1. **Do not cut wet grass.** For effective mulching do not cut wet grass. Wet grass sticks to the underside of the deck prevention proper mulching and dispersal of grass clippings.
2. **Cut no more than 1/3 the length of the grass.** When mulching long grass, it may be necessary to mow twice, lowering the deck another 1/3 of the length for the second cut, and perhaps cutting in a different pattern. Overlap the cut on each pass to help clean up any heavy clippings left on the lawn.
3. **Use a slow ground speed.** Adjust ground speed so clippings can be evenly dispersed into the lawn. When cutting heavy grass, it may be necessary to use a slower ground speed in order to get a well mulched cut.
4. **Always operate the tractor at full throttle.** To obtain the best cut and do the most effective job of mulching, the engine should be run at full throttle.
5. **Clean underside of deck.** Be certain to clean the underside of the deck often to avoid a buildup of grass clippings, which will prevent proper mulching.

OPTIONAL EQUIPMENT AND ACCESSORIES

When you purchased your tractor, you probably had it completely equipped for your particular needs at the time. However, later you may wish to obtain optional equipment or accessories. These items and other allied equipment can be purchased from, and installed by, your authorized *Cub Cadet* dealer.

The tractor is used for so many different types of work, and because it is called on to operate under so many different conditions, a variety of equipment is available to adapt it to the requirements of the user. **Refer to the attachment guide for a complete description of equipment and required components that can be utilized with your tractor.**

MAINTENANCE CHART

Operation to be performed	Before each use	10 hours or once a month	Every 25 hours	30 hours or three times a season	50 hours or twice a season	100 hours or yearly	Before storage
Clean grille, engine air inlet screen, dash intake screen and side panels screens		More often under dirty conditions X					
Check engine oil level	X						
Fill fuel tank	X						
Change engine oil & oil filter	After first 5-8 hours				More often under dirty conditions X		
Check transmission oil level	X						
Replace transmission oil filter		After first 10 hours X			After first 50 hours X	Every 100 hours thereafter X	
Clean air precleaner			X				
Check battery terminals and case		X					
Grease front axle pivot bolt		X					
Grease steering knuckles		X					
Retorque rear wheel lug nuts		After first 10 hours					
Clean cooling fins & external surfaces						X	
Service air cleaner paper cartridge						X More often under dirty conditions	
Check spark plugs						X	X
Grease steering arm housing				X			X
Grease front wheel bearings				X			X
Drain fuel							X
Pivot bar adjustment bolts					X		
Deck spindles		X					X
Spindle belt idler arm		X					X
Deck front gauge wheels					X		X
Lubricate all foot and lift control pivot points		X					X

NOTE

Maintenance information for optional equipment may be found in the manual which is included with that specific piece of equipment.

TROUBLE SHOOTING

Possible Cause

Possible Remedy

HARD TO START

No gasoline in fuel tank or carburetor	Fill the tank with gasoline. Check the fuel line, carburetor and fuel filter.
Fuel line or carburetor clogged.....	Clean the fuel line and carburetor with a commercial carburetor cleaner.
Fuel filter plugged.....	Replace.
Water in gasoline.....	Drain the fuel tank and carburetor. Use new fuel and dry the spark plugs.
Choked improperly. Flooded engine	Follow the starting instructions.
Defective ignition or loose wiring.....	Check the wiring, spark plugs or fuse.
Defective battery	Check and service. Refer to “ BATTERY. ”
Spark plug dirty or improper gap	Clean, adjust the gap to .030-inch or replace the plug.

ENGINE OPERATES IRREGULARLY OR KNOCKS

Engine incorrectly timed	*
Spark plug dirty; wrong gap or wrong type.....	Clean, reset the gap or replace.
Poor or weak spark	Check the spark plugs and wiring.
Carburetor setting incorrect.....	Adjust. Refer to “ ADJUSTMENTS. ”
Poor grade fuel or water in fuel	Drain and use a good grade of clean fuel.
Engine overheating	Refer to “ MAINTENANCE. ”
Engine valves at fault	*
Engine smokes.....	Adjust the carburetor.*
Oil level rises due to gasoline in crankcase	*
Air filter becomes oil and fuel soaked.....	*
Engine leaks oil	*
Misfiring	*
Other engine problems.....	*
Excessive oil in air cleaner	Be sure that oil dipstick is fully seated and oil fill cap is securely tightened in valve cover.

PTO CLUTCH WILL NOT ENGAGE

Low or zero voltage.....	Check battery. Charge or replace. Check charging system. Check for worn or broken wiring or connections. Check clutch coil resistance. Check switch.
Rotor/armature air gap too large	Rotor/armature worn. Replace PTO clutch.

* See your authorized dealer.

TROUBLE SHOOTING

Possible Cause	Possible Remedy
LACK OF POWER	
Air cleaner clogged	Service the air cleaner element. Refer to “ MAINTENANCE. ”
Engine overload	Reduce the load.
Engine overheated	Make sure the air intake screen, shrouding, engine fins, side panels, dash intake screen and grille are free of accumulated dirt and debris. Refer to “ MAINTENANCE. ”
Fuel tank air vent clogged	Remove obstruction from the vent in the fuel tank cap.
Air leakage between carburetor and engine	Remove air cleaner. Tighten the carburetor and manifold mounting nuts. Replace any damaged parts as indicated in “ MAINTENANCE. ”
Incorrect timing or faulty ignition	*
Brake dragging	Adjust the brake. Refer to “ ADJUSTMENTS. ”
Insufficient cooling air — dirt or debris clogging the: air intake screen • shrouds • cooling fins • side panels • dash intake screen • or grille	Keep the air intake area, side panels, grille, dash intake screen and cooling fins clean; refer to “ MAINTENANCE. ”
Oil level incorrect	Engine oil level must not be over the “ FULL ” mark or below the “ LOW ” mark on dipstick. Refer to “ MAINTENANCE. ”

* See your authorized dealer.

LUBRICATION TABLE

Point of Lubrication	Check at Hours	Change at Hours	Capacity	Anticipated Air Temperature		
				Above +40°F	0° to 40°F	-20°F to 100°+
Engine crankcase	Check before each use	50	Approx. 3 pints	Cub Cadet Engine Oil SAE 30	Cub Cadet Engine Oil SAE5W30 or 10W30	Synthetic Engine Oil SAE 5W30 or 10W30
Hydro drive unit and transmission case with filter	Check before each use	Add as needed	Approx. 6 qts	Cub Cadet Drive System Fluid Plus NOTE: <i>Cub Cadet</i> Drive System Fluid Plus is specially formulated for this application. If any other oil is used <i>Cub Cadet</i> will not be responsible for substandard performance. Failures due to use of improper fluid are not covered by warranty. For maximum protection, use <i>Cub Cadet</i> Drive System Fluid.Plus		
Steering knuckles and front axle pivot bolt	10			Use 251H EP grease or equivalent No. 2 multi-purpose lithium grease and apply two strokes (minimum) or sufficient grease to flush out old grease and dirt.		
Front wheel bearings	30			Two strokes (minimum) of the lubricator using 251H EP grease or equivalent No. 2 multi-purpose lithium grease.		
Steering arm housing	30			Two strokes (minimum) of the lubricator using 251H EP grease or equivalent No. 2 multi-purpose lithium grease.		
Deck spindles	10			Two strokes (minimum) of the lubricator using 251H EP grease or equivalent No. 2 multi-purpose lithium grease.		
Spindle belt idler arm	10			Two strokes (minimum) of the lubricator using 251H EP grease or equivalent No. 2 multi-purpose lithium grease.		
Deck front gauge wheels	50			Use 251H EP grease or equivalent No. 2 multi-purpose lithium grease.		
Foot and lift control pivot points	10			Use a liberal amount of high grade lubricating oil.		

LUBRICATION GUIDE



WARNING

The service life and reliability of any machine depends upon the care it is given. Proper lubrication is a very important part of that care. This lubrication schedule reflects the minimal requirements to maintain the equipment. More frequent inspections and maintenance is preferable.

NOTE: *We do not recommend the use of a pressure washer or garden hose to clean your unit. They may cause damage to electrical components; spindles; pulleys; bearings; or the engine. The use of water will result in shortened life and reduce serviceability.*

Using the lubrication illustration as a guide, make certain that all lubrication fittings are installed and functioning.

Be sure all fittings are free from dirt and paint so the lubricant is certain to enter the bearing.

Using a pressure lubricating gun, always force the lubricant through the full length of each bearing until it emerges at the end, carrying with it the worn lubricant and any dirt that may have entered the bearing.

Miscellaneous working parts not provided with lubrication fittings should be oiled regularly with a good grade of lubricating oil.

Always lubricate the tractor thoroughly before taking it to a remote location for a prolonged period of time.

Lubricant is cheap. Use plenty of it. Worn parts can be expensive to replace.

Keep your supply of lubricating oil and grease stored in clean containers, and covered to protect from dust and dirt.

Keep the lubricating gun nozzle clean and wipe dirt from the grease fittings before lubricating.

The symbols in the illustrations indicate the method of application and the hourly intervals to apply the lubricant.



Use a pressure lubricating gun and apply 251H EP grease (or equivalent No. 2 multi-purpose lithium grease) sufficient to flush out the old grease and dirt. Lubricate at the hourly intervals indicated on the symbols.



Dipstick, use to check engine and transmission oil before each use.

LUBRICATION GUIDE

—Before Each Use

1. Engine filler cap and dipstick
Check the oil (with the engine stopped) and add sufficient new oil to bring it to the “FULL” mark on the dipstick. Do not overfill. Do not operate the engine if the oil level is below the “LOW” mark on the dipstick.
2. Transmission oil level and fill port
Check the oil with the engine stopped. Keep the lubricant up to the “FULL” mark on the dipstick.

NOTE: The transmission oil level and fill port services the following:

1. Rear axle
2. Hydrostatic transmission

—After Every 10 Hours of Operation

3. Steering knuckles (2) (both sides)
Use 251H EP grease or an equivalent No. 2 multi-purpose lithium grease and apply sufficient grease to flush out old grease and dirt.
4. Transmission oil filter
NOTE: After the first 10 hours only, remove the transmission oil filter and replace with a new filter. Refer to “**MAINTENANCE.**” Change the transmission oil filter after 50 hours and every 100 hours of operation thereafter.
5. Front axle pivot bolt
Use 251H EP grease or an equivalent No. 2 multi-purpose lithium grease and apply sufficient grease to flush out old grease and dirt.
6. Foot and lift control pivot points
Use a liberal amount of high grade lubricating oil.
7. Deck spindles
Use 251H EP grease or an equivalent No. 2 multi-purpose lithium grease and apply 2 strokes (minimum) or sufficient grease to flush out old grease and dirt.
8. Spindle belt idler arm
Use 251H EP grease or an equivalent No. 2 multi-purpose lithium grease and apply 2 strokes (minimum) or sufficient grease to flush out old grease and dirt.

—After Every 30 Hours of Operation

9. Front wheel bearings
Two or three strokes minimum of the lubricator using 251H EP grease or an equivalent No. 2 multi-purpose lithium grease.
10. Steering arm housing
Every 30 hours or three times a season, use 251H EP grease or an equivalent No. 2 multi-purpose lithium grease. Apply two strokes with lubricator.

—After Every 50 Hours of Operation

11. Transmission oil filter
NOTE: After the first 50 hours only, remove the transmission oil filter and replace with a new filter. Refer to “**MAINTENANCE.**” Change the transmission oil filter every 100 hours of operation thereafter.
12. Engine oil drain valve and oil filter
While the engine oil is warm, open the drain valve and remove the oil filter, and drain all of the oil from the crankcase. Close the drain valve. Refer to “**MAINTENANCE,**” “**FILLING THE CRANKCASE**” and “**OIL FILTER**” for proper oil filling procedure. Refer to “**LUBRICATION TABLE**” for the proper quantity and viscosity to use.
13. Deck front gauge wheels
Use 251H EP grease or an equivalent No. 2 multi-purpose lithium grease and apply sufficient grease to flush out old grease and dirt.

—After Every 100 Hours of Operation

14. Transmission oil filter
Change the transmission oil filter and replace with a new filter. Refer to “**MAINTENANCE.**”



Lubrication information for optional equipment may be found in the manual which is included with the specific piece of optional equipment.

LUBRICATION GUIDE

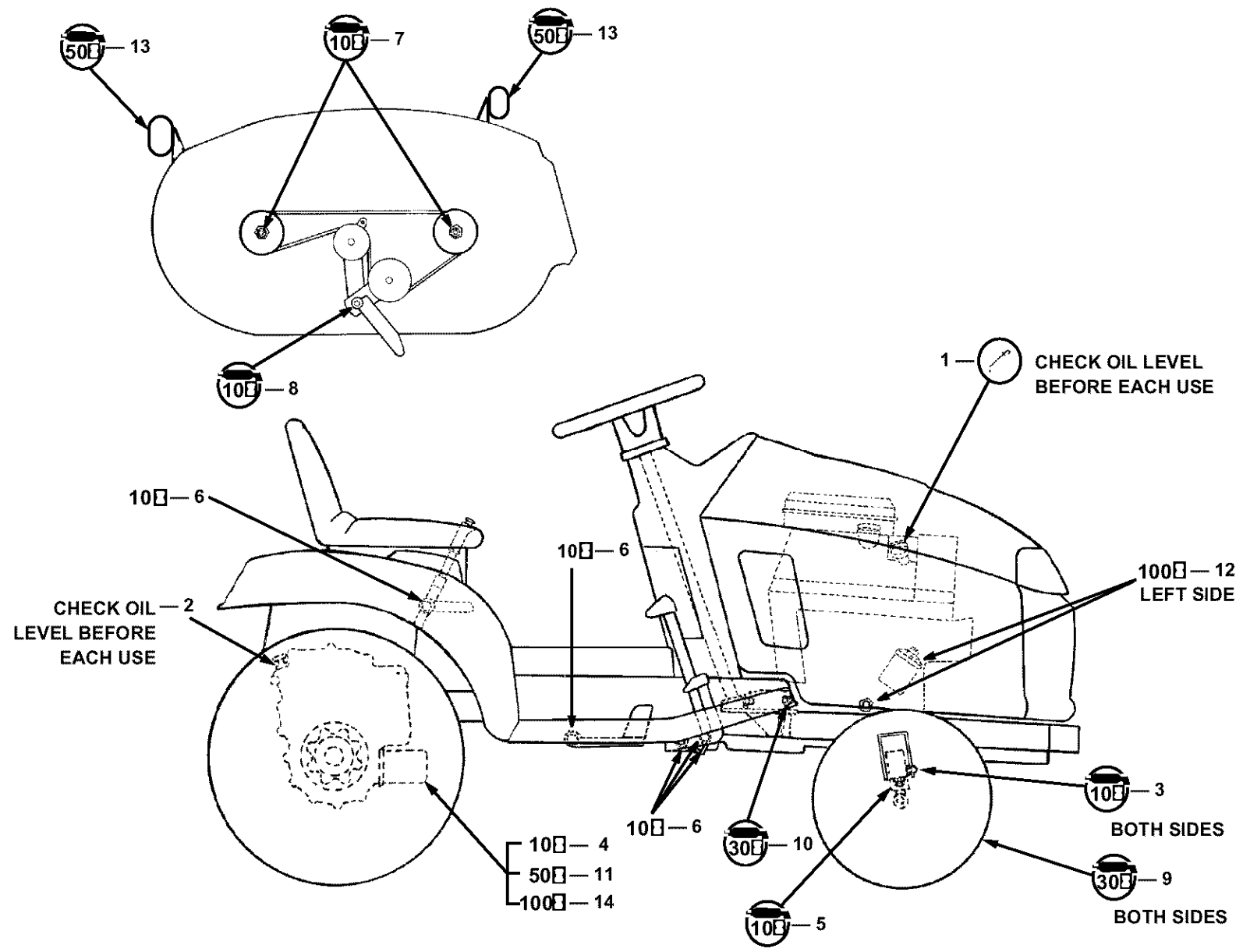

USE THIS PAGE AS A GUIDE TO DETERMINE SLOPES WHERE YOU MAY NOT OPERATE SAFELY.

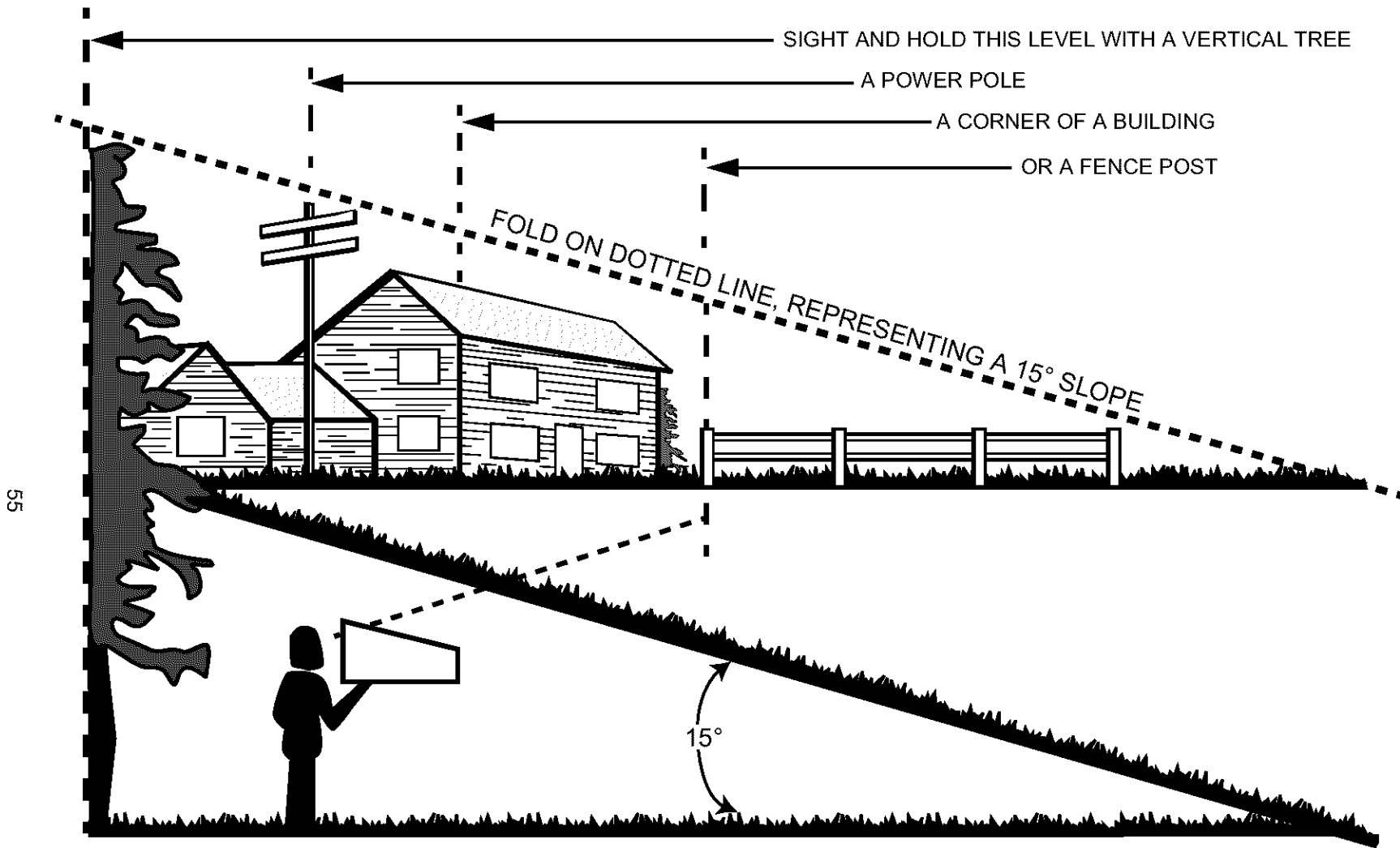

(Keep this sheet in a safe place for future reference.)

SLOPE GAUGE



WARNING

Do not mow on inclines with a slope in excess of 15 degrees (a rise of approximately 2-1/2 feet every 10 feet). A riding mower could overturn and cause serious injury. If operating a walk-behind mower on such a slope, it is extremely difficult to maintain your footing and you could slip, resulting in serious injury. Operate RIDING mowers up and down slopes, never across the face of slopes. Operate WALK-BEHIND mowers across the face of slopes, never up and down slopes.

SPECIFICATIONS

	LT 2180
CAPACITIES	
Fuel Tank	2-1/8 gallons
Crankcase (approximately)	3 pints (48 oz.)
Transmission Case (approximately)	6 quarts
HYDROSTATIC DRIVE	
Speed: Forward	0 to 6 mph
Reverse	0 to 3 mph
ENGINE	
Make and Model	B & S Vanguard
Horsepower	18.0 HP
Cylinders	2
Bore	2.83 in.
Stroke	2.76 in.
Displacement (cubic inches)	34.7
Engine Speed (governed)	
Low Speed	1200 RPM
High Speed	
(no load)	3600 RPM
(full load)	3350 RPM
Valve Clearance (engine cold)	
Intake004-.006 in.
Exhaust004-.006 in.
Ignition	Battery
Spark Plug Gap (Cub Cadet No. 759-3336)030 in.
ELECTRICAL SYSTEM	
System Voltage	12 volt neg. ground
Battery	725-1706
Alternator	15 amp regulated
Fuse (auto type)	25 amp
Head Lamp Bulb	725-0963
BRAKES	Internal expanding
TIRE SIZES	
Front	15 x 6-6
Rear	20 x 9-8
DIMENSIONS	
Tread:	
Front with 15 x 6-6 tires	30.00 in.
Rear with 20 x 9-8 tires	27.50 in.
Wheelbase	47.00 in.
Length, over all	72.00 in.
Width, over all (w/ mower deck - chute up)	51.00 in.
Height, over all (to top of steering wheel)	42.00 in.
Ground Clearance	6.00 in.
Turning Radius	26.50 in.

Specifications are subject to change without notice.

CUB CADET CORPORATION MANUFACTURER'S ONE YEAR LIMITED WARRANTY (COMMERCIAL USE)

The limited warranty set forth below is given by CUB CADET LLC ("CUB CADET") with respect to new merchandise purchased and used in the United States, its possessions and territories.

CUB CADET warrants this product against defects in material and workmanship for a period of **one (1) year** for commercial users, commencing on the date of original purchase and will, at its option, repair or replace, free of charge, any part found to be defective in material or workmanship. This limited warranty shall only apply if this product has been operated and maintained in accordance with the Operator's Manual furnished with the product, and has not been subject to misuse, abuse, neglect, accident, improper maintenance, alteration, vandalism, theft, fire, water or damage because of other peril or natural disaster. Damage resulting from the installation or use of any part, accessory or attachment not approved by Cub Cadet for use with the product(s) covered by this manual will void your warranty as to any resulting damage.

Batteries and belts are subject to separate terms as follows:

- a. Batteries have a one-year prorated limited warranty with 100% replacement during the first three months. After three months, the battery replacement credit is based on the months remaining in the twelve (12) month period dating back to the original date of sale. Any replacement battery will be warranted only for the remainder of the original warranty period.
- b. All belts are covered by a one (1) year limited warranty against defects in material and workmanship.

HOW TO OBTAIN SERVICE: Warranty service is available, WITH PROOF OF PURCHASE, THROUGH YOUR LOCAL AUTHORIZED CUB CADET DEALER. To locate the dealer in your area, please check for a listing in the Yellow Pages or contact Cub Cadet LLC at P.O. Box 361131, Cleveland, Ohio 44136-0019, or call 1-877-282-8684, or log on to our Web site at www.cubcadet.com.

This limited warranty does not provide coverage in the following cases:

- a. Routine maintenance items such as lubricants, filters, tune-ups, or adjustments such as brake adjustments, or clutch adjustments; and normal deterioration of the exterior finish due to use or exposure.
- b. Normal wear parts or components, including batteries, belts, seats and tires.

- c. CUB CADET does not extend any warranty for products sold or exported outside of the United States of America, its possessions and territories, except those sold through CUB CADET'S authorized channels of export distribution.
- d. Replacement parts that are not genuine Cub Cadet parts.
- e. Service completed by someone other than an authorized service dealer.

No implied warranty, including any implied warranty of merchantability or fitness for a particular purpose, applies after the applicable period of express written warranty above. No other express warranty or guaranty, whether written or oral, except as mentioned above, given by any person or entity, including the dealer, with respect to any product shall bind CUB CADET. During the period of the Warranty, the exclusive remedy is repair or replacement of the product as set forth above. (Some states do not allow limitations on how long an implied warranty lasts, so the above limitation may not apply to you.)

The provisions as set forth in this Warranty provide the sole and exclusive remedy arising from the sale. CUB CADET shall not be liable for incidental or consequential loss or damages including, without limitation, to any claim for loss of profits, loss of savings or revenue, loss of the use of the equipment or any associated equipment, facilities or service, downtime, the claims or costs of third parties including customers, and injury to property, and further including expenses incurred for substitute or replacement lawn care services, for transportation or for related expenses, or for rental expenses to temporarily replace a warranted product. (Some states do not allow the exclusion or limitation of incidental or consequential damages, so the above exclusion may not apply to you.)

In no event shall recovery of any kind be greater than the amount of the purchase price of the product sold. Alteration of the safety features of the product shall void this Warranty. You assume the risk and liability for loss, damage, or injury to you and your property and/or to others and their property arising out of the use or misuse or inability to use the product.

This limited warranty shall not extend to anyone other than the original purchaser or original lessee.

How State Law Relates to this Warranty: This limited warranty gives you specific legal rights, and you may also have other rights which vary from state to state.

IMPORTANT: Owner must present Original Proof of Purchase to obtain warranty coverage.
Cub Cadet LLC, P.O. BOX 361131 CLEVELAND, OHIO 44136-0019; Phone: 1-877-282-8684

CUB CADET CORPORATION MANUFACTURER'S LIMITED WARRANTY (RESIDENTIAL USE)

The limited warranty set forth below is given by CUB CADET CORPORATION ("CUB CADET") with respect to new merchandise purchased and used in the United States, its possessions and territories.

CUB CADET warrants this product against defects in material and workmanship for a period of two (2) years for residential users, (one (1) year for commercial users), commencing on the date of original purchase and will, at its option, repair or replace, free of charge, any part found to be defective in material or workmanship. This limited warranty shall only apply if this product has been operated and maintained in accordance with the Operator's Manual furnished with the product, and has not been subject to misuse, abuse, neglect, accident, improper maintenance, alteration, vandalism, theft, fire, water or damage because of other peril or natural disaster. Damage resulting from installation or use of any part, accessory, or attachment not approved by Cub Cadet for use with the product(s) covered by this manual will void your warranty as to any resulting damage.

Batteries and belts are subject to separate terms as follows:

- a. Batteries have a one-year prorated limited warranty with 100% replacement during the first three months. After three months, the battery replacement credit is based on the months remaining in the twelve (12) month period dating back to the original date of sale. Any replacement battery will be warranted only for the remainder of the original warranty period.
- b. All belts are covered by a one (1) year limited warranty against defects in material and workmanship.

3 Year Limited Warranty - PTO Clutch

CUB CADET warrants the power take off (PTO) clutch and mounting hardware against defects in material and workmanship for a period of three (3) years for Series 2000 products for residential users, commencing on the date of original purchase or lease and CUB CADET will, at its option, repair or replace, free of charge, any PTO clutch or mounting hardware found to be defective in material or workmanship provided this product has been operated and maintained as set forth above.

5 Year/500 Hour Limited Warranty

CUB CADET warrants the frame, front cast iron pivot axle and drive shaft on Series 2000 and 3000 models against defects in material and workmanship for a period of five (5) years or 500 hours, whichever occurs first, for residential users, commencing on the date of original purchase or lease and CUB CADET will, at its option, repair or replace, free of charge, any part found to be defective in material or workmanship provided this product has been operated and maintained as set forth above. In addition to any other reason set forth herein, CUB CADET may deny warranty coverage if the hour meter, or any part thereof, is altered, modified, disconnected or otherwise tampered with.

HOW TO OBTAIN SERVICE: Warranty service is available, WITH PROOF OF PURCHASE, THROUGH YOUR LOCAL AUTHORIZED CUB CADET DEALER. To locate the dealer in your area, please check for a listing in the Yellow Pages or contact Cub Cadet LLC at P.O. Box 361131, Cleveland, Ohio 44136-0019, or call 1-877-282-8684, or log on to our Web site at www.cubcadet.com.

This limited warranty does not provide coverage in the following cases:

- a. Routine maintenance items such as lubricants, filters, blade sharpening, tune-ups, brake adjustments, clutch adjustments, deck adjustments, and normal deterioration of the exterior finish due to use or exposure.
- b. CUB CADET does not extend any warranty for products sold or exported outside of the United States of America, its possessions and territories, except those sold through CUB CADET's authorized channels of export distribution.
- c. Replacement parts that are not genuine Cub Cadet parts.
- d. Service completed by someone other than an authorized service dealer.
- e. Transportation charges and service calls.

No implied warranty, including any implied warranty of merchantability or fitness for a particular purpose, applies after the applicable period of express written warranty above as to the parts as identified. No other express warranty, whether written or oral, except as mentioned above, given by any person or entity, including the dealer, with respect to any product, shall bind CUB CADET. During the period of the warranty, the exclusive remedy is repair or replacement of the product as set forth above.

The provisions as set forth in this Warranty provide the sole and exclusive remedy arising from the sales. CUB CADET shall not be liable for incidental or consequential loss or damages including, without limitation, expenses incurred for substitute or replacement lawn care services or for rental expenses to temporarily replace a warranted product.

Some states do not allow the exclusion or limitation of incidental or consequential damages, or limitations on how long an implied warranty lasts, so the above exclusions or limitations may not apply to you.

In no event shall recovery of any kind be greater than the amount of the purchase price of the product sold. **Alteration of the safety features of the product shall void this Warranty.** You assume the risk and liability for loss, damage, or injury to you and your property and/or to others and their property arising out of the use or misuse or inability to use the product.







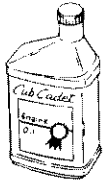
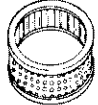

This limited warranty shall not extend to anyone other than the original purchaser or to the person for whom it was purchased as a gift.

How State Law Relates to this Warranty: This limited warranty gives you specific legal rights, and you may also have other rights which vary from state to state.

IMPORTANT: Owner must present Original Proof of Purchase to obtain warranty coverage.

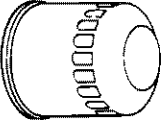
Cub Cadet LLC, P.O. BOX 361131 CLEVELAND, OHIO 44136-0019; Phone: 1-877-282-8684

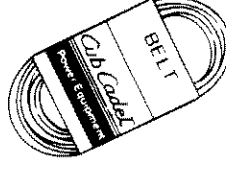
MAINTENANCE PARTS CHART

MODEL LT 2180		SERIES 2000 18 HP VANGUARD	
ENGINE OIL 	Engine Oil Requirements approx. . . 3 pints Cub Cadet engine oil Ambient temperature viscosity (Grade SG,SH,SJ or Higher) Above +40°F SAE 30 0° to +40°F SAE 5W30 or 10W30 -20° to 100°+F Synthetic SAE 5W30 or 10W30		Part No. 737-3029 737-3030A (10W30)
AIR FILTER   CARTRIDGE FOAM PRE-CLEANER	Air Filter Requirements Clean air filter per instructions in your Operator's Manual under Maintenance - Air cleaner.		Part No. Cartridge BS-394018 Foam Pre-cleaner BS-272490
ENGINE OIL FILTER 	Engine Oil Filter Requirements Change every 50 hours		Part No. BS-492932
SPARK PLUG 	Gap Requirements .030 inch gap		Part No. 759-3336
TRANSMISSION OIL FILTER 	Oil Filter Requirements) Change every 100 hours		Part No. 923-3014
TRANSMISSION OIL 	Transmission Oil Requirements approx. . . 6 qts Check before each use <div style="display: flex; justify-content: space-around;"> 1 quart 737-3120 </div> <div style="display: flex; justify-content: space-around;"> 1 gallon 737-3121 </div>		Part No. 737-3120 737-3121
BELTS 	Deck Blade Belt		Tractor to Deck Belt
	Model	Part No.	Model
	42" Deck	954-3073	42" Deck
			Part No.
			754-04041
BLADES 	Mower Deck Blade		Part No.
	42" Deck 3 in 1 Blade		759-3830 (2)