

OPERATOR'S MANUAL



Transmatic Garden Tractor

Models

820 Thru 828

840 Thru 848

IMPORTANT: Read safety rules and instructions carefully before operating equipment.

Warning: This unit is equipped with an internal combustion engine and should not be used on or near any unimproved forest-covered, brush-covered or grass-covered land unless the engine's exhaust system is equipped with a spark arrester meeting applicable local or state laws (if any). If a spark arrester is used, it should be maintained in effective working order by the operator. In the State of California the above is required by law (Section 4442 of the California Public Resources Code). Other states may have similar laws. Federal laws apply on federal lands. A spark arrester for the muffler is available through your nearest engine authorized service dealer or contact the service department, P.O. Box 361131 Cleveland, Ohio 44136-0019.

MTD LLC, P.O. BOX 361131 CLEVELAND, OHIO 44136-0019

PRINTED IN U.S.A.

FORM NO. 770-10119C
(12/2001)

TABLE OF CONTENTS

Content	Page
Important Safe Operation Practices	3
Slope Gauge	6
Hardware Pack.....	7
Unpacking	8
Assembling Your Garden Tractor	8
Know Your Garden Tractor.....	15
Operating Your Garden Tractor.....	17
Making Adjustments	19
Maintaining Your Garden Tractor	22
Off-Season Storage	24
Optional Equipment.....	25
Troubleshooting	26

FINDING MODEL NUMBER

This Operator's Manual is an important part of your new Garden Tractor. It will help you assemble, prepare and maintain the unit for best performance. Please read and understand what it says.



Before you start assembling your new equipment, please locate the model plate on the equipment and copy the information from it in the space provided below. The information on the model plate is very important if you need help from our Customer Support Department or an authorized dealer.

- You can locate the model number by pivoting the seat forward and looking under the seat at the seat pivot bracket. A sample model plate is explained below. For future reference, please copy the model number and the serial number of the equipment in the space below.

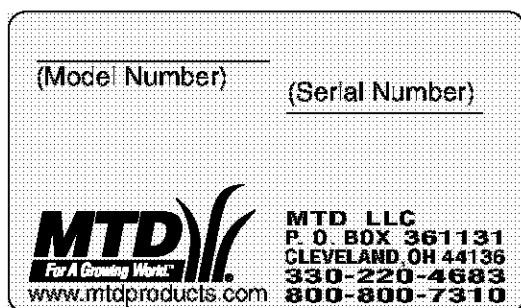

Copy the model number here: _____

Copy the serial number here: _____

ENGINE INFORMATION

The engine manufacturer is responsible for all engine-related issues with regards to performance, power-rating, specifications, warranty and service. Please refer to the engine manufacturer's Owner's/Operator's Manual packed separately with your unit for more information.

CALLING CUSTOMER SUPPORT

If you have difficulty assembling this product or have any questions regarding the controls, operation or maintenance of this unit, please call the Customer Support Department.



Call 1- (330) 220-4MTD (4683) or 1- (800)-800-7310 to reach a Customer Support representative. Please have your unit's model number and serial number ready when you call. See previous section to locate this information. You will be asked to enter the serial number in order to process your call .

For more details about your unit, visit our website at www.mtdproducts.com

SECTION 1: IMPORTANT SAFE OPERATION PRACTICES



WARNING: This symbol points out important safety instructions which, if not followed, could endanger the personal safety and/or property of yourself and others. read and follow all instructions in this manual before attempting to operate your lawn mower. failure to comply with these instructions may result in personal injury. When you see this symbol, heed its warning.



WARNING: The Engine Exhaust from this product contains chemicals known to the State of California to cause cancer, birth defects or other reproductive harm.

DANGER: Your lawn mower was built to be operated according to the rules for safe operation in this manual. As with any type of power equipment, carelessness or error on the part of the operator can result in serious injury. This lawn mower is capable of amputating hands and feet and throwing objects. Failure to observe the following safety instructions could result in serious injury or death.

General Operation

- Read, understand, and follow all instructions in the operator's manual and on the machine before starting. Keep this manual in a safe place for future and regular reference and for ordering replacement parts.
- Only allow responsible individuals familiar with the instructions to operate the machine. Know controls and how to stop the machine quickly.
- Do not put hands or feet under cutting deck or near rotating parts.
- Clear the area of objects such as rocks, toys, wire, etc., which could be picked up and thrown by the blade. A small object may have been overlooked and could be accidentally thrown by the mower in any direction and cause injury to you or a bystander. To help avoid a thrown objects injury, keep children, bystanders and helpers at least 75 feet from the mower while it is in operation. Always wear safety glasses or safety goggles during operation or while performing an adjustment or repair, to protect eyes from foreign objects. Stop the blade(s) when crossing gravel drives, walks or roads.
- Be sure the area is clear of other people before mowing. Stop machine if anyone enters the area.
- Never carry passengers.
- Disengage blade(s) before shifting into reverse and backing up. Always look down and behind before and while backing.
- Be aware of the mower and attachment discharge direction and do not point it at anyone. Do not operate the mower without either the entire grass catcher or the chute guard in place.
- Slow down before turning. Operate the machine smoothly. Avoid erratic operation and excessive speed.
- Never leave a running machine unattended. Always turn off blade(s), place transmission in neutral, set park brake, stop engine and remove key before dismounting.
- Turn off blade(s) when not mowing.
- Stop engine and wait until blade(s) comes to a complete stop before (a) removing grass catcher or unclogging chute, or (b) making any repairs, adjusting or removing any grass or debris.
- Mow only in daylight or good artificial light.
- Do not operate the machine while under the influence of alcohol or drugs.
- Watch for traffic when operating near or crossing roadways.
- Use extra care when loading or unloading the machine into a trailer or truck. This unit should not be driven up or down a ramp onto a trailer or truck under power, because the unit could tip over, causing serious personal injury. The unit must be pushed manually on a ramp to load or unload properly.
- Never make a cutting height adjustment while engine is running if operator must dismount to do so.
- Wear sturdy, rough-soled work shoes and close-fitting slacks and shirts. Do not wear loose fitting clothes or jewelry. They can be caught in moving parts. Never operate a unit in bare feet, sandals, or sneakers.
- Check overhead clearance carefully before driving under power lines, wires, bridges or low hanging tree branches, before entering or leaving buildings, or in any other situation where the operator may be struck or pulled from the unit, which could result in serious injury.
- Disengage all attachment clutches, thoroughly depress the brake pedal, and shift into neutral before attempting to start engine.
- Your mower is designed to cut normal residential grass of a height no more than 10". Do not attempt to mow through unusually tall, dry grass (e.g., pasture) or piles of dry leaves. Debris may build up

on the mower deck or contact the engine exhaust presenting a potential fire hazard.

Slope Operation

Slopes are a major factor related to loss of control and tip-over accidents which can result in severe injury or death. All slopes require extra caution. If you cannot back up the slope or if you feel uneasy on it, do not mow it.

For your safety, use the slope gauge included as part of this manual to measure slopes before operating this unit on a sloped or hilly area. If the slope is greater than 15° as shown on the slope gauge, do not operate this unit on that area or serious injury could result.

Do:

- Mow up and down slopes, not across.
- Remove obstacles such as rocks, limbs, etc.
- Watch for holes, ruts or bumps. Uneven terrain could overturn the machine. Tall grass can hide obstacles.
- Use slow speed. Choose a low enough gear so that you will not have to stop or shift while on the slope. Always keep machine in gear when going down slopes to take advantage of engine braking action.
- Follow the manufacturer's recommendations for wheel weights or counterweights to improve stability.
- Use extra care with grass catchers or other attachments. These can change the stability of the machine.
- Keep all movement on the slopes slow and gradual. Do not make sudden changes in speed or direction. Rapid engagement or braking could cause the front of the machine to lift and rapidly flip over backwards which could cause serious injury.
- Avoid starting or stopping on a slope. If tires lose traction, disengage the blade(s) and proceed slowly straight down the slope.

Do Not:

- Do not turn on slopes unless necessary; then, turn slowly and gradually downhill, if possible.
- Do not mow near drop-offs, ditches or embankments. The mower could suddenly turn over if a wheel is over the edge of a cliff or ditch, or if an edge caves in.
- Do not mow on wet grass. Reduced traction could cause sliding.
- Do not try to stabilize the machine by putting your foot on the ground.
- Do not use grass catcher on steep slopes.

Children

Tragic accidents can occur if the operator is not alert to the presence of children. Children are often attracted to the machine and the mowing activity. Never assume

that children will remain where you last saw them.

- Keep children out of the mowing area and in watchful care of an adult other than the operator.
- Be alert and turn machine off if children enter the area.
- Before and when backing, look behind and down for small children.
- Never carry children, even with the blades off. They may fall off and be seriously injured or interfere with the safe machine operation.
- Never allow children under 14 years old to operate the machine. Children 14 years and over should only operate machine under close parental supervision and proper instruction.
- Use extra care when approaching blind corners, shrubs, trees or other objects that may obscure your vision of a child or other hazard.
- Remove key when machine is unattended to prevent unauthorized operation.

Service

- Use extreme care in handling gasoline and other fuels. They are extremely flammable and the vapors are explosive.
- Use only an approved container.
- Never remove fuel cap or add fuel with the engine running. Allow engine to cool at least two minutes before refueling.
- Replace fuel cap securely and wipe off any spilled fuel before starting the engine as it may cause a fire or explosion.
- Extinguish all cigarettes, cigars, pipes and other sources of ignition.
- Never refuel the machine indoors because fuel vapors will accumulate in the area.
- Never store the fuel container or machine inside where there is an open flame or spark, such as a gas hot water heater, space heater or furnace.
- Never run a machine inside a closed area.
- To reduce fire hazard, keep the machine free of grass, leaves or other debris build-up. Clean up oil or fuel spillage. Allow machine to cool at least 5 minutes before storing.
- Before cleaning, repairing or inspecting, make certain the blade and all moving parts have stopped. Disconnect the spark plug wire, and keep the wire away from the spark plug to prevent accidental starting.
- We do not recommend the use of pressure washers or garden hose to clean your unit. They may cause damage to electric components, spindles, pulleys, bearings or the engine. The use of water will result in shortened life and reduce serviceability.
- Check the blade and engine mounting bolts at frequent intervals for proper tightness. Also,

visually inspect blade for damage (e.g., excessive wear, bent, cracked). Replace with blade which meets original equipment specifications.

- Keep all nuts, bolts and screws tight to be sure the equipment is in safe working condition.
- Never tamper with safety devices. Check their proper operation regularly. Use all guards as instructed in this manual.
- After striking a foreign object, stop the engine, remove the wire from the spark plug and thoroughly inspect the mower for any damage. Repair the damage before restarting and operating the mower.
- Grass catcher components are subject to wear, damage and deterioration, which could expose moving parts or allow objects to be thrown. For your safety protection, frequently check components and replace with manufacturer's recommended parts when necessary.
- Mower blades are sharp and can cut. Wrap the blade(s) or wear gloves and use extra caution when servicing blade(s).
- Check brake operation frequently. Adjust and service as required.
- Muffler, engine and belt guards become hot during operation and can cause a burn. Allow to cool down before touching.

- Do not change the engine governor settings or overspeed the engine. Excessive engine speeds are dangerous.
- Observe proper disposal laws and regulations. Improper disposal of fluids and materials can harm the environment and the ecology.
- Prior to disposal, determine the proper method to dispose of waste from your local Environmental Protection Agency. Recycling centers are established to properly dispose of materials in an environmentally safe fashion.
- Use proper containers when draining fluids. Do not use food or beverage containers that may mislead someone into drinking from them. Properly dispose of the containers immediately following the draining of fluids.
- DO NOT pour oil or other fluids into the ground, down a drain or into a stream, pond, lake or other body of water. Observe Environmental Protection Agency regulations when disposing of oil, fuel, coolant, brake fluid, filters, batteries, tires and other harmful waste.

Your Responsibility

- Restrict the use of this power machine to persons who read, understand and follow the warnings and instructions in this manual and on the machine.

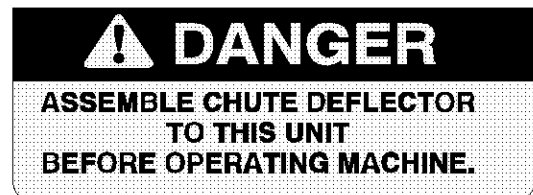
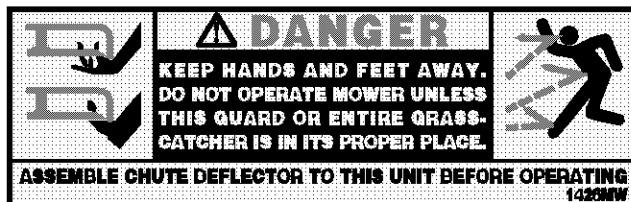

USE THIS PAGE AS A GUIDE TO DETERMINE SLOPES WHERE YOU MAY NOT OPERATE SAFELY.

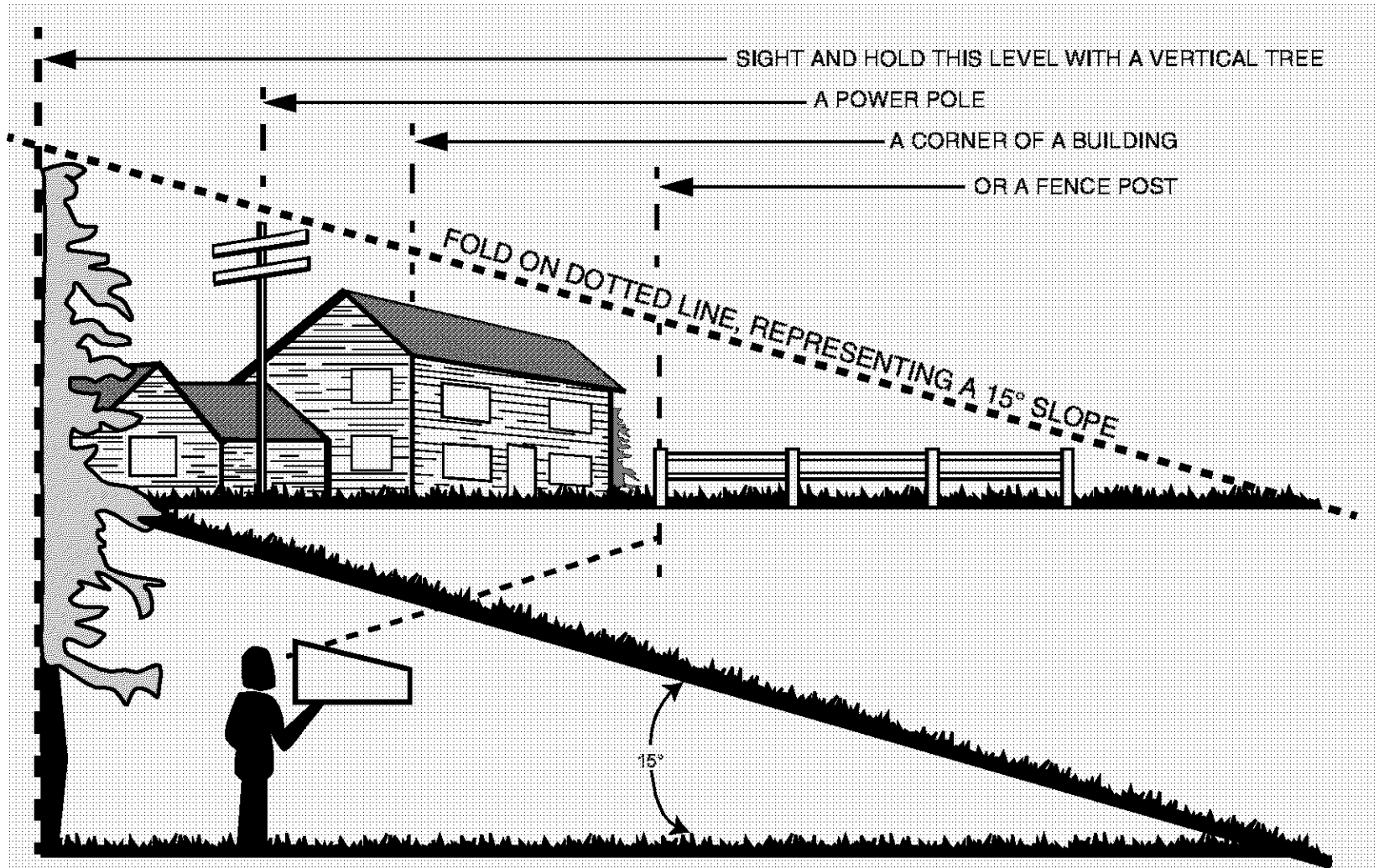

SECTION 2: SLOPE GAUGE



WARNING

Do not mow on inclines with a slope in excess of 15 degrees (a rise of approximately 2-1/2 feet every 10 feet). A riding mower could overturn and cause serious injury. If operating a walk-behind mower on such a slope, it is extremely difficult to maintain your footing and you could slip, resulting in serious injury.

Operate RIDING mowers up and down slopes, never across the face of slopes.

Operate WALK-BEHIND mowers across the face of slopes, never up and down slopes.

SECTION 3: HARDWARE PACK

NOTE: Hardware pack may contain extra items which are not used on your unit. Part numbers are shown in parentheses.

A ATTACHING THE DECK LINKS

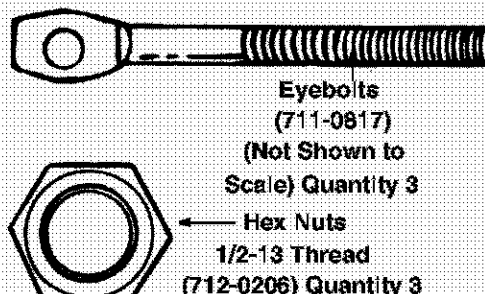

Eyebolts
(711-0817)
(Not Shown to Scale) Quantity 3

Hex Nuts
1/2-13 Thread
(712-0206) Quantity 3

B ATTACHING THE CUTTING DECK

NOTE: This hardware may be assembled to the deck

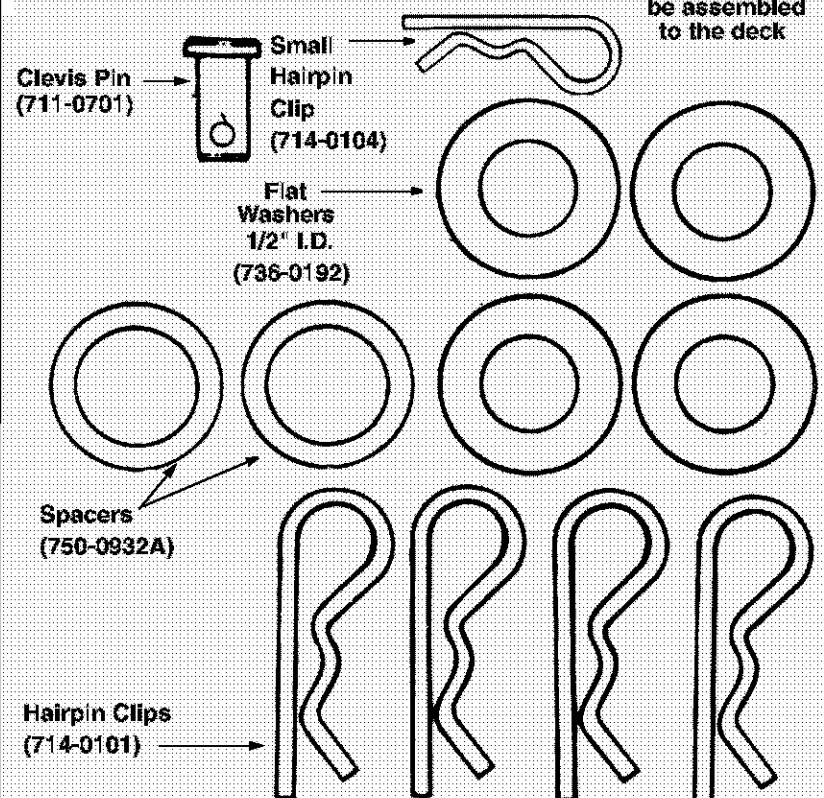

Clevis Pin (711-0701)

Small Hairpin Clip (714-0104)

Flat Washers 1/2" I.D. (736-0192)

Spacers (750-0932A)

Hairpin Clips (714-0101)

C ATTACHING THE DECK WHEELS (if not already attached)

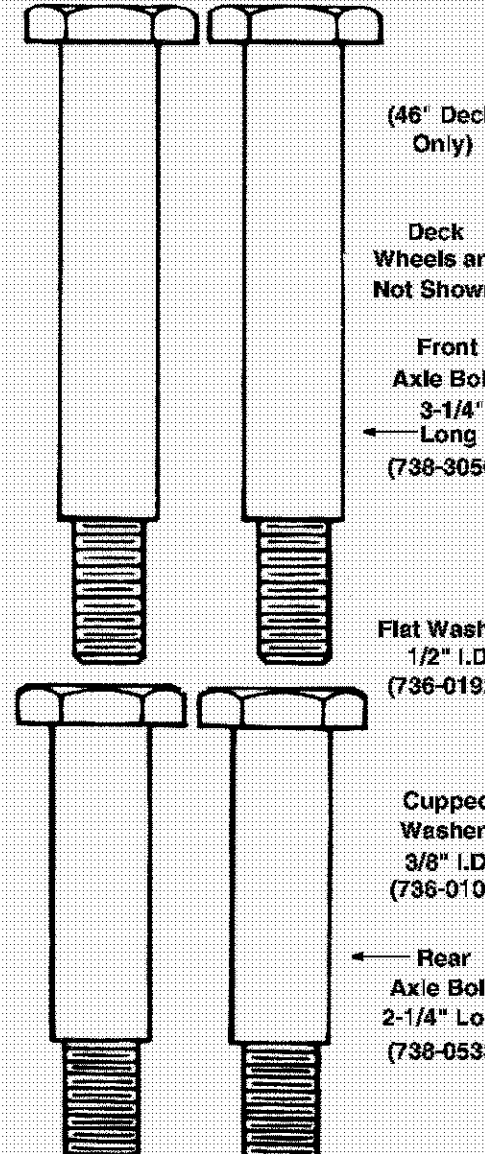

(46" Deck Only)

Deck Wheels are Not Shown

Front Axle Bolts 3-1/4" Long (738-3056)

Rear Axle Bolts 2-1/4" Long (738-0533)

Flat Washers 1/2" I.D. (736-0192)

Cupped Washers 3/8" I.D. (736-0105)

Lock Washers 3/8" I.D. (736-0169)

Hex Nuts 3/8-16 Thread (712-0798)

SECTION 4: ASSEMBLING YOUR GARDEN TRACTOR

Unpacking

- Remove all screws and staples from top of crate using a 1/4" hex head socket or a screw driver.
- To remove ends, grasp top board on the end, and pull towards you in a downward motion. (A hammer may help). Set panel aside to avoid tire punctures.
- Repeat procedure for each side of the crate.
- Remove and discard plastic bag which covers unit.
- Loose parts (operator's manual, steering wheel, battery fluid, chute deflector, etc.) are on the seat or in a box and wrapped in plastic. Carefully cut and remove the plastic wrap. Remove loose parts from the seat and save.
- Remove deck from beneath the tractor. Make sure that parking brake is released and unit is in neutral.

NOTE: See the controls section of this manual for location of the parking brake release and the shift lever.

- Push unit off the skid.
- Lay out the contents of the hardware pack on the illustration on page 7 for identification.

IMPORTANT: After assembly, service engine with gasoline, and check oil level as instructed in the engine manual packed separately with your unit.

NOTE: Reference to right or left hand side of the unit is observed from the driver's seat, facing forward.

Tools Required

1. 1/4" socket wrench or flat blade screwdriver
2. 1/2" wrench or socket wrench for models with square steering wheel cap
3. 9/16" wrench or socket wrench
4. Two 7/16" wrenches or socket wrenches

Setting up the Battery



WARNING: Always shield eyes, protect skin and clothing when working near batteries. Handle battery acid with great care as contact with it can burn and blister the skin. Follow the steps below to ensure safe handling.

- a. Wear protective clothing (goggles, rubber gloves and apron) to work with battery.
- b. Should battery acid accidentally splatter into the eyes or onto the face, rinse the affected area immediately with clean cold water. A list of antidotes are given below. If there is any further discomfort, seek medical attention.

Antidote: EXTERNAL—Flush with water.

INTERNAL—Drink large quantities of water

or milk. Follow with milk of magnesia, beaten eggs or vegetable oil. If discomfort persists, call physician immediately.

EYES: Flush with cool water for at least 15 minutes, then get prompt medical attention.

- c. If acid spills on clothing, first dilute it with clean water, then neutralize with a solution of ammonia/ water or baking soda/water.
- d. Since battery acid is corrosive, do not pour it into any sink or drain. Before discarding empty electrolyte containers, rinse them with a neutralizing solution.
- e. NEVER connect or disconnect charger clips to battery while the charger is turned on as it can cause sparks.
- f. Keep all lighted materials (cigarettes, matches, lighters) away from the battery as the hydrogen gas generated during charging can be combustible.
- g. As a further precaution, only charge the battery in a well-ventilated area.



WARNING: Keep battery away from children. Do not activate battery (fill with battery acid) until battery is actually placed in service. Be certain to read previous battery warnings before activating the battery.

Identifying Battery Type

- Compare the battery in your lawn tractor (located under the seat) with Figure 1. Type "A" batteries are activated and are ready to use. Type "B" batteries must be filled with battery fluid (acid) and charged before they are put into service. Follow pertinent instructions.

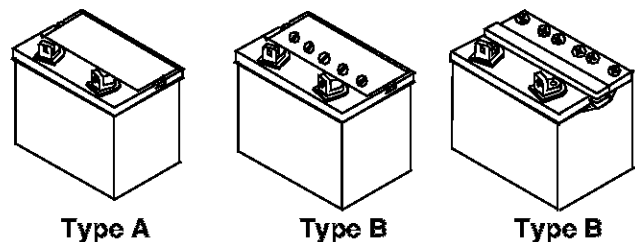

Figure 1

Charging the Battery

Type A Battery

NOTE: If the battery on your tractor is of the A type, it is already activated and is ready to use. Skip the following section of assembly and proceed to Attaching Steering Wheel. You will, however, need to install the battery on the tractor later on in the assembly.

Type B Battery

- Lift the hood of the tractor and locate the battery. See Figure 2. Remove the wing nuts from the hold-down rods on two sides of the battery. Disconnect the positive cable from the positive terminal. Save the hardware for reassembly.

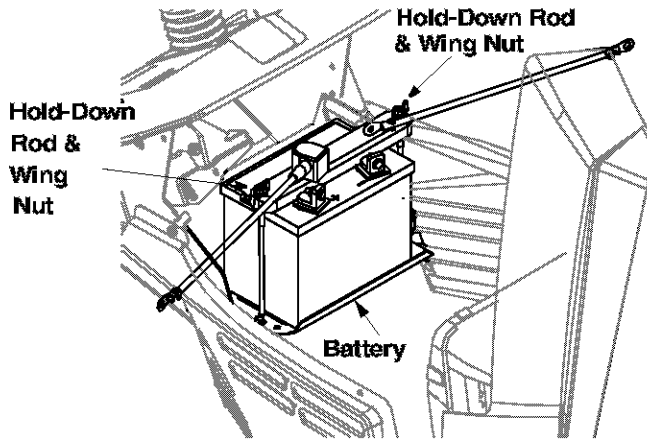

Figure 2

- Remove the battery from the tractor, paying attention to how the battery is placed on the unit, and how the drain tube is routed.
- Activate the battery as instructed in the "Quick Start" brochure included with the battery fluid. **Read instructions carefully.**

NOTE: You can continue assembling the tractor while battery is standing for 30 minutes (after filling with acid), and later while the battery is being charged.

IMPORTANT: To obtain maximum life from the battery, it must be charged prior to initial use.

- Charge battery after the 30-minute standing period following the chart below.

Battery Part Number	Charging Duration	Amperes
725-1705D	1 Hour	2-3
725-1707D	1 Hour	6
725-0453G	1 Hour	6
725-1750	1 Hour	6
725-1706	1 Hour	6

NOTE: If you charge the battery at a lower AMP rate, use a hydrometer to make sure the battery is completely charged. The hydrometer should read 1.260 minimum at an electrolyte temperature of 60-110°F. Do not charge at more than 6 amps.

Attaching Steering Wheel

- The hardware for attaching the steering wheel has been packed inside the steering wheel. Carefully pry off the steering wheel cap and remove hardware for assembly.

- Remove the steering bellow from the lift lever on the right hand side of tractor. Place steering bellow over the steering shaft extending through the dash. See Figure 3.

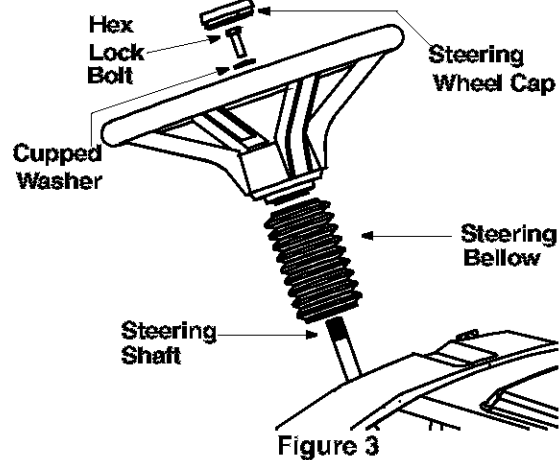

Figure 3

NOTE: If the openings on each end of the steering bellow are of two sizes, the smaller end goes down against the dash of the tractor.

- Keeping the wheels of the tractor pointing straight forward, place the steering wheel over the steering shaft. Place the washer with the cupped side down over the steering shaft. Secure with hex lock bolt. See Figure 3.

NOTE: If the steering wheel cap is square, you **must** use a socket wrench.

- Place the steering wheel cap over the center of the steering wheel and adjust to secure.

Attaching the Seat

One of two types of seats are used on these garden tractor models: a manual adjustment seat and a quick adjustment seat. See Figure 4 and Figure 5 to identify which seat is on your unit. Follow instructions pertaining to your garden tractor model only.

Manual Adjustment Seat

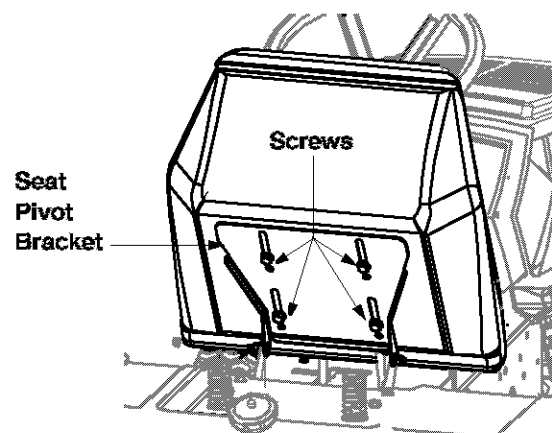

Figure 4

- Remove the four screws which secure the seat to the seat pivot bracket.

NOTE: If the seat was shipped in a box, remove four screws from the bottom of the seat and place the seat in position against the seat pivot bracket.

- Turn the seat around and place in position against the seat pivot bracket, lining up the slotted holes in the pivot bracket with the holes in the seat. Select desired position for the seat, and secure with the four screws. See Figure 4.

Quick Adjustment Seat

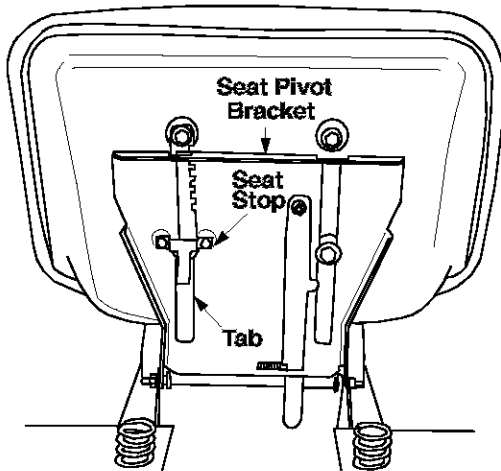

Figure 5

- Pull out tab on seat stop and hold open while sliding seat out of seat pivot bracket. See Figure 5.
- Turn the seat around and line up plastic seat spacers with the slots in seat pivot bracket.
- Slide seat in until front seat spacer engages the seat stop. See Figure 6. To adjust the seat refer to the adjustment section in this manual.

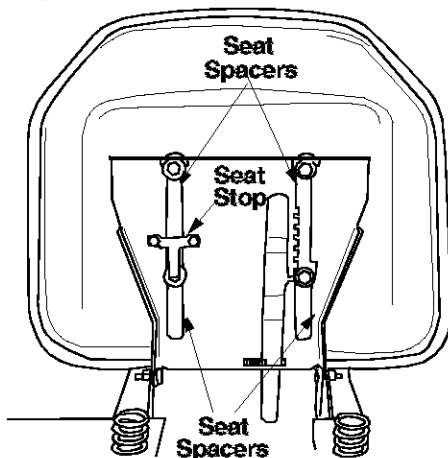

Figure 6

NOTE: If the seat was shipped in a box, line up plastic seat spacers with the slots in seat pivot bracket and slide seat in until front seat spacer engages seat stop.



WARNING: Quick adjustment seat only: Before operating tractor, stand behind the seat and pull back on it to make sure the seat is engaged in the seat stop.

Attaching Deck Links

(Hardware A)

The three adjustable deck links have been shipped unassembled. Attach as follows.

- Start 1/2" hex nuts on eyebolts until nuts are flushed with ends of eyebolts. See Figure 7.
- Insert eyebolts and hex nuts into the adjustable lift links located under the tractor. See Figure 7.
- Thread eyebolts into the lift links and hex nuts. The left rear link should be adjusted so the eyebolt hangs about 3-1/2 inches below the lift link. The two front links should be adjusted so the eyebolts hang about 2-1/8 inches below the lift links. See Figure 7.

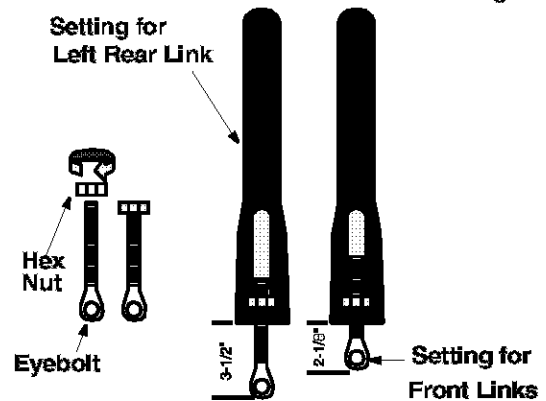

Figure 7

Attaching the Deck

(Hardware B)

NOTE: An assistant may be helpful for this job.

- Working beneath the tractor, remove the hairpin clip securing the round belt guard to the idler. See Figure 8. Remove the two hex bolts which act as belt keepers by the engine pulley.

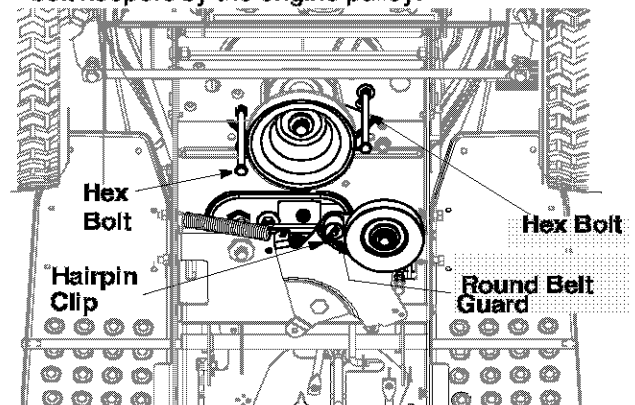

Figure 8

- Move the tractor lift handle all the way back to the fully raised position. Turn the tractor steering wheel all the way to the right.
- **50" Decks:** Remove the roller assembly from the rear of the deck and set aside.
- The two deck stabilizers and the diagonal brace which are attached to the front of the deck are folded back over the deck for shipping purposes. Unfold them at this time. See Figure 9.
- Slide the deck under the tractor from the left side. You may need to angle the deck slightly to get the braces past the front wheel.

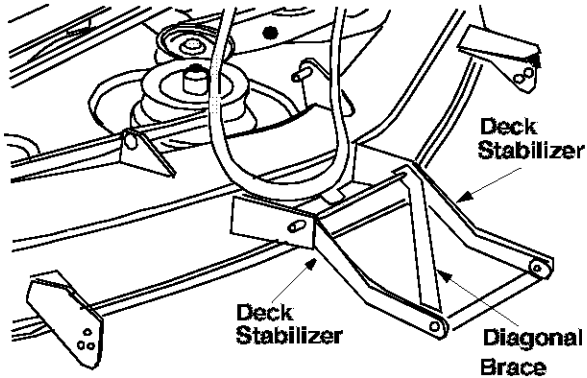

Figure 9

NOTE: When attaching the cross bar, reference to the right or left hand side is observed facing front of the tractor, rather than from the operating position.

- Standing in front of the tractor, remove the hairpin clips from the cross bar. See Figure 10.
- Slide the cross bar to the left until the right side is free. Drop bar down and slide to the right until cross bar is removed from the tractor. See Figure 10.

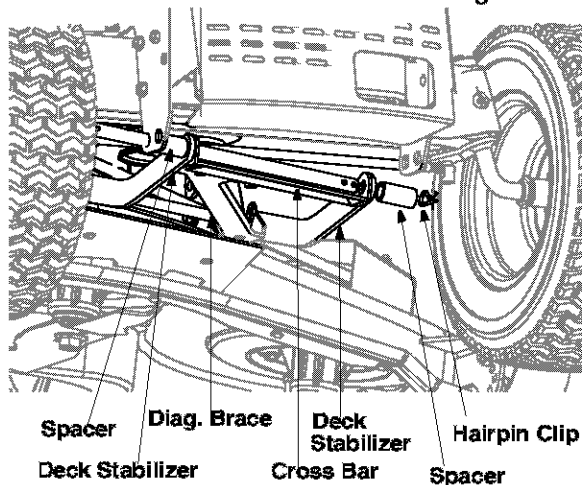

Figure 10

- Insert cross bar through the two deck stabilizers and the diagonal brace. See Figure 11A.
- Place a spacer on the left end of the cross bar. Pull the bar to the right until the spacer is flushed with the end of the bar as shown in Figure 11B. Lift

assembly and slide the cross bar into one of the holes on the left side of frame. Secure with hairpin clip removed earlier.

46" Deck: Use the rear set of holes.

50" Deck: Use the forward set of holes.

- Place a spacer on the right end of the cross bar. See Figure 11C.
- Pull the bar to the left until the spacer is flushed with the end of the bar. Slide the cross bar into the hole on the right side of frame. Secure with hairpin clip. Refer to Figure 10.
- Move the lift lever forward to the lowest position.

NOTE: It may be necessary to pull down on the lift links to obtain the lowest position.

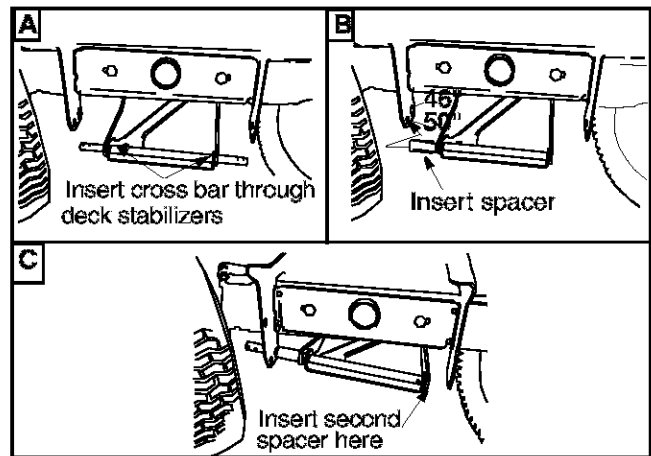

Figure 11

- Lift up on the edge of the deck and attach the left front deck hanger to the deck using a flat washer and hairpin clip. Make sure deck hanger goes through the center of V-Belt. See Figure 12.

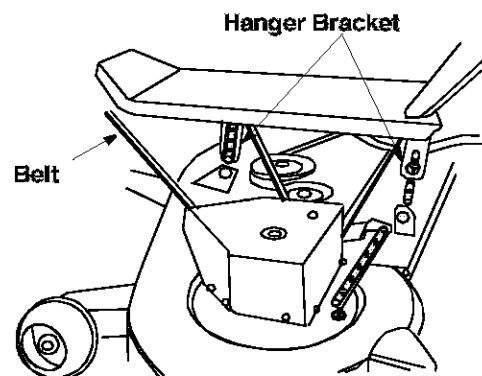

Figure 12

- Attach the right front hanger to the deck using a flat washer and hairpin clip.
- Move lift lever back to the fully raised position.
- **50" Deck only:** Remove the clevis pins and hairpin clips from the roller assembly. Slide the roller assembly between the rear wheels and the deck.

Insert the deck roller brackets up through the brackets provided on the rear of the deck. It may be necessary to rotate the deck roller brackets 360° to clear the roll pin stop. Attach with clevis pins and hairpin clips just removed, using the lowest hole location on each side of the deck. See Figure 13.

- Move the lift lever forward to the lowest position.
- Attach the two rear lift links with flat washers and hairpin clips.
- Place deck belt around the engine pulley. Make certain the deck belt is seated in the deck pulley.

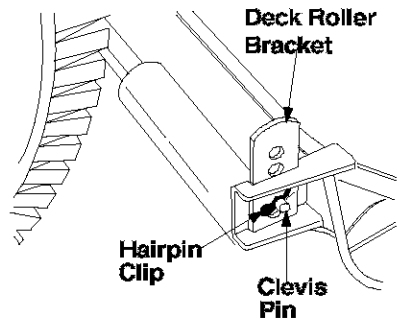

Figure 13

- Push the idler bracket to the left and slip the belt around the idler pulley. Replace the round belt guard by the idler pulley (hex side down). Secure with hairpin clip.
- Replace the hex bolts (belt keepers) by the engine pulley. Refer to Figure 8.
- Check all belt guards for clearance. The belt guards must be between 1/16" and 1/8" away from the belt when the PTO lever is in the engaged position (be sure to disengage the PTO lever after checking).
- Secure the brake release cable to the tractor idler bracket with clevis pin and small hairpin clip, using the hole in the idler bracket as shown in Figure 14.

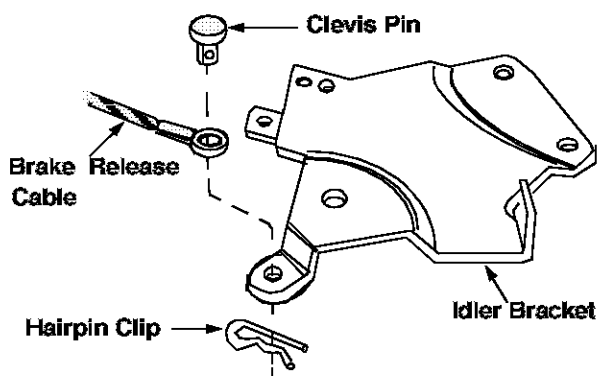

Figure 14

Attaching Chute Deflector



WARNING: Do not operate the tractor unless the chute deflector has been properly installed.

- **50" Deck only:** Remove the bolts, nuts and cupped washers which are attached to the deck next to the chute opening. Place the chute deflector in position as shown in Figure 15. (For 46" decks, please refer to Figure 16.) Secure with hardware removed earlier.

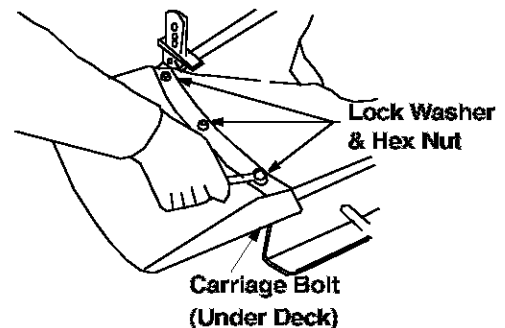

Figure 15

Attaching Deck Wheels

(Hardware C)

46" Deck

If the deck wheels are not already attached, attach the wheels to the deck as follows. All wheels must be placed in the same relative position.

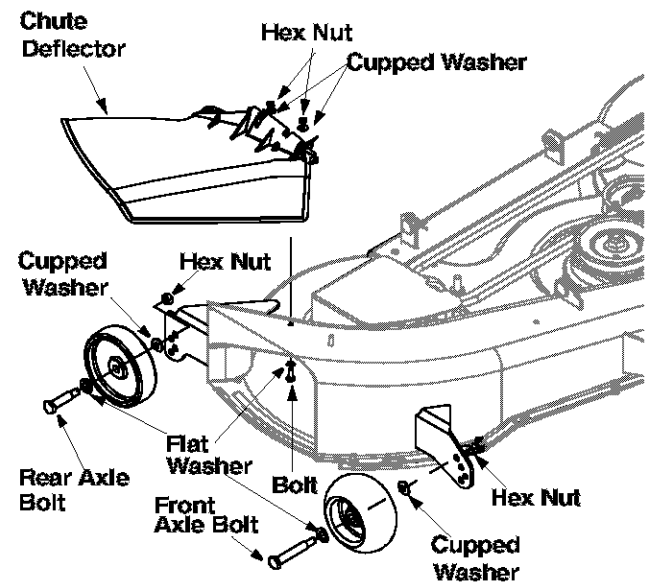

Figure 16

Front Wheels: Front axle bolts are the longer bolts. Front deck wheels have a rounded surface.

Rear Wheels: Rear axle bolts are the shorter bolts. Rear deck wheels are flatter.

- Place flat washer on the axle bolt, then the deck wheel and cupped washer (crowned side of washer goes against the wheel). See Figure 16.
- Secure to deck with hex nut. Tighten securely. Assemble remaining wheels in same manner.

Tire Pressure

The tires on your tractor may be over-inflated for shipping purposes. Reduce the tire pressure before operating the unit. Check the sidewall of the tires for proper inflation pressure.



WARNING: Maximum tire pressure under any circumstances is 30 p.s.i. Equal tire pressure should be maintained on all tires.

Leveling the Deck

After attaching the deck to the tractor, make sure it is adjusted properly.

- Check tire pressure of all four tires. See sidewall of tire for recommended inflation pressure.
- Make certain all deck wheels or both ends of the deck roller are mounted in same relative hole locations. Place the tractor on a level surface.
- **46" Deck:** Lower the deck until it reaches the ground. All four deck wheels should reach the ground at the same time.
- Place the deck approximately 1" above the ground. The distance from the bottom edge of the deck to the ground must be same on both sides of the deck.

Adjusting Deck Links

If adjustment is necessary, adjust the deck links on the left side of the deck as follows.

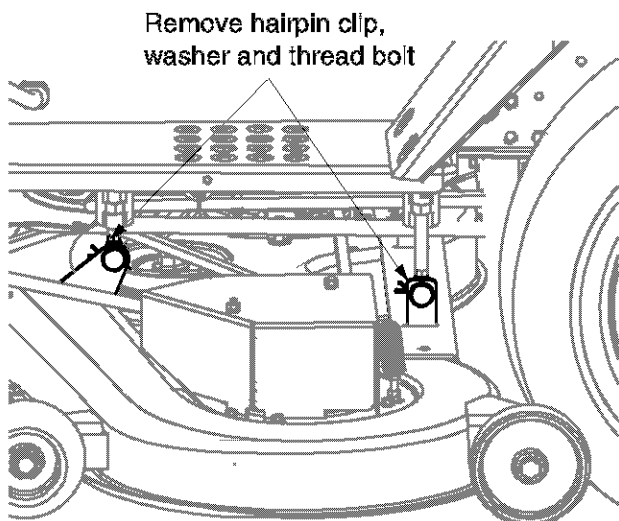

Figure 17

- Make certain the PTO is disengaged. Remove hairpin clip and washer from the weld bolt. See Figure 17. Thread eyebolt up or down the link as necessary, and reassemble.
- Make sure that the front of the deck is 1/4" to 3/8" lower than the rear of the deck. If it is not, adjust the two front links to obtain this distance.

Installing the Battery

Type A Battery

NOTE: If battery is put into service after date shown on top of battery, charge for minimum 1 hour at 6 amps.

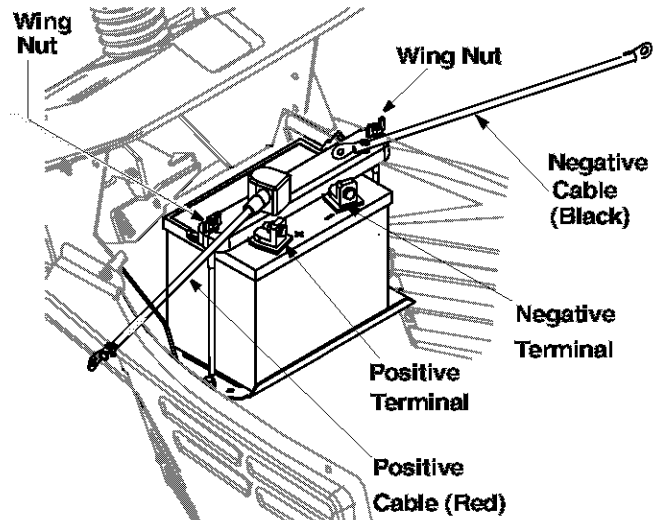

Figure 18

- Lift the hood of the tractor. Remove wing nuts from the hold-down rods securing battery cover to the battery.
- Remove plastic cover from the negative terminal.
- Remove the hex bolt and nut from the negative (black) cable. Attach negative cable to the negative terminal with this bolt and nut. See Figure 18.
- Place battery cover over battery and secure with wing nuts removed earlier.

NOTE: It may be necessary to pull up on the hold-down rods in order to start the wing nuts

Type B Battery

NOTE: The positive battery terminal is marked Pos. (+). The negative battery terminal is marked Neg. (-).

- Place the battery on the battery plate with the terminals toward the front of the tractor.
- Attach the positive cable (heavy red wire) to the positive battery terminal (+) with hex bolt and hex nut. See Figure 18. Slide the rubber boot over the positive terminal.
- Remove hex bolt and nut from the negative cable. Attach the negative cable (heavy black wire) to the negative battery terminal (-) with the bolt and nut.
- Place the battery cover in position over the hold-down rods. Secure with wing nuts. See Figure 18.

NOTE: It may be necessary to pull up on the hold-down rods in order to start the wing nuts.

- Route the battery drain tube (if equipped) over to the left side of the tractor. Loosen the self-tapping

screw which secures the mounting clamp. See Figure 19. Slip the end of the drain tube into the mounting clamp. Tighten the self-tapping screw to secure the clamp. Do not overtighten which could collapse the drain tube.

NOTE: *The vented battery allows any gases or liquid from the battery to be drained onto the ground.*

- Trim end of drain tube if more than 1 inch extends below the frame.

Final Assembly

- Make certain all nuts and bolts are tightened securely.

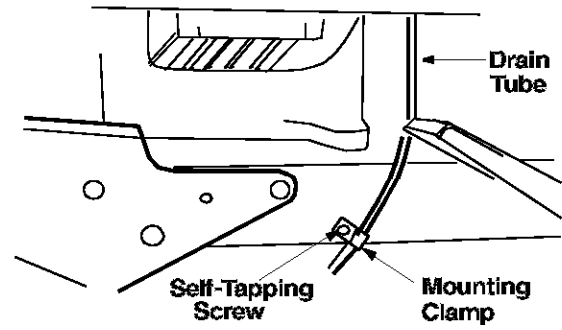

Figure 19

SECTION 5: KNOW YOUR GARDEN TRACTOR

This section is meant to acquaint you with the various types of controls and switches available on these tractors. Please read this section carefully and know your tractor well before operating. As with any power equipment, it is extremely important to ensure proper and safe operation of the tractor by following the instructions closely. Note that this manual covers various models and many controls, listed here, may be optional items.

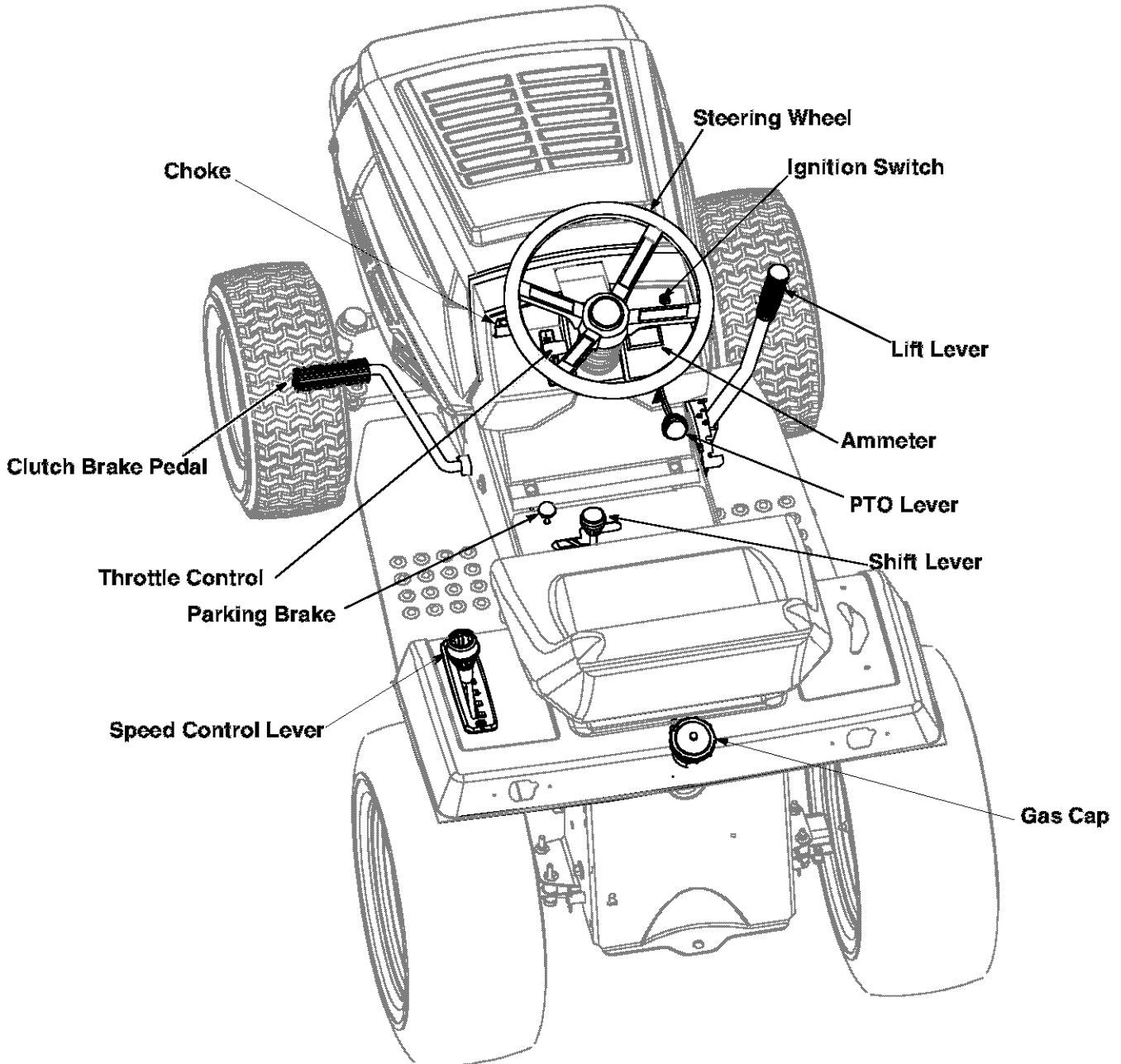

Figure 20

Ignition Key

The ignition key switch is located on the dashboard. To start the engine, turn the key clockwise to the START position. Once the engine has cranked, put the key in the ON position. To stop the engine, turn the key to the OFF position. To prevent accidental starting, **remove key** from the tractor when the tractor is not in use.

Ignition/Light Switch

The lights are controlled by the ignition switch. With the tractor running, turn the key counter-clockwise to the **LIGHTS ON** position.

Throttle Control

The throttle control is located on the left side of the dashboard and is used to regulate engine speed. The

throttle has to be set at FAST position to start the engine. Same position has to be maintained while operating any attachment (such as the mowing deck, snow thrower or rotary tiller) that uses the tractor engine as a source of power .

Choke Control

The choke control is located on the dashboard and is operated manually. Details about choke operation are included in the engine manual.

Ammeter (If equipped)

The ammeter registers the rate of battery charge or discharge. The ammeter will register on the discharging side when starting the engine. It should register on the charging side when the engine is running in the FAST position until the battery is completely charged. With a fully charged battery or with the engine idling, the ammeter will not show a charge.

Clutch-Brake Pedal

The clutch-brake pedal is located on left side of tractor.

- To disengage the clutch only, depress the clutch-brake pedal part way.
- To engage the disc brake as well, depress the pedal fully.

NOTE: *The clutch-brake pedal must be depressed to start the engine.*

Lift Lever

The five-position lift lever is used to change the operating position of the attachments.

- To operate, pull the lever towards you.
- To release, move the lever to the right and forward.

Power Take-Off (PTO) Lever

The PTO lever is located on the right side of the dashboard. The PTO lever is used to engage and disengage the power to the attachments.

- To engage the PTO, lift the lever slowly and lock it into the notch.

IMPORTANT: The PTO lever **must** be in the disengaged position (down) when starting the engine, when shifting into reverse and if the operator leaves the seat.

Shift Lever

The shift lever is located in the center of the console and has four positions: HIGH, LOW, NEUTRAL and REVERSE.

- Depress the clutch-brake pedal and slide the shift lever to the desired position.

NOTE: *The clutch-brake pedal must be depressed and the tractor must not be moving when shifting gears. Do not force the shift lever. If necessary, release the clutch-brake pedal slightly to line up the shifting collar in the transmission. Then try to shift gears.*

Parking Brake

The parking brake is located in front of the shift lever as shown in Figure 20 .

- To set the parking brake, depress the clutch-brake pedal and pull up the parking brake knob. It will stay in the raised position. To release the parking brake, depress and release the clutch-brake pedal.

NOTE: *The parking brake must be set if the operator leaves the seat with the engine running.*

Speed Control Lever

The speed control lever is located on the left fender. It allows you to regulate the ground speed of the garden tractor.

- To select ground speed, depress clutch pedal. Push speed control lever outward and move backward to slow garden tractor, move forward to increase speed. When desired speed has been reached, release lever. Whenever clutch is engaged, the tractor will automatically go to the pre-set speed.

SECTION 6: OPERATING YOUR GARDEN TRACTOR

Maintaining Safety



WARNING: As with any type of power equipment, carelessness or error on the part of the operator can result in serious injury. Read and follow the instructions in this manual very carefully. Avoid serious injury or death by mishandling the equipment.

Do:

- Go up and down slopes, not across; avoid sudden turns.
- If machine stops while going uphill, stop blade(s) and come back downhill slowly.
- Look down and behind before and while backing.
- Keep safety devices (guards, shields, and switches) in place and working.
- Remove objects that could be thrown by the blade(s).
- Know location and function of all controls. Refer to earlier section on page 15.
- Be sure blade(s) and engine are stopped before placing hands or feet near blade(s).
- Before leaving operator's position, disengage blade(s), place the shift lever in neutral, engage brake lock, shut engine off and remove key.

Do Not:

- Do not operate the unit where it could slip or tip.
- Do not mow when children or others are around.
- Never carry children on the tractor, even with the blades off.

Gas and Oil Fill-Up

- Check oil level and add if necessary.

IMPORTANT: Your tractor is shipped with oil in the engine; however, you must check the engine oil level before operating. Be careful not to overfill.

- Service the engine with gasoline as instructed in the separate engine manual packed with your tractor. Read instructions carefully.
- The fuel tank is located under the seat. The filler neck is behind the seat. Fill up with the required amount of gasoline. However, do not overfill.



WARNING: Never fill fuel tank indoors, with engine running or while engine is hot.

Starting Engine

IMPORTANT: This unit is equipped with a **safety interlock system** for your protection. The safety

interlock system is to prevent the engine from cranking or starting unless the clutch-brake pedal is depressed and the PTO lever is in the disengaged position. In addition, the PTO lever must be in the disengaged position when the unit is put into reverse or the engine will shut off. If the operator leaves the seat with the PTO lever engaged and/or without setting the parking brake, the engine will automatically shut off.



WARNING: Do not operate the tractor if the interlock system is malfunctioning because it is a safety device designed for your protection.

- Place the PTO lever in the disengaged (down) position.
- Depress the clutch-brake pedal and set the parking brake.
- Place the shift lever in the NEUTRAL position.
- Set the throttle control in the FAST position.
- Pull out the choke control (a warm engine may not require choking).
- Turn ignition key to the right to START position. After the engine starts, release the key. It will return to the ON position.
- Slowly push in the choke as the engine warms up.

Stopping Engine

- Turn ignition key to the left to the OFF position. Remove the key to prevent accidental starting.

IMPORTANT: If the tractor strikes a foreign object, stop the engine. Remove wire from spark plug, thoroughly inspect the unit for any damage, and repair the damage before restarting and operating the equipment.

Stopping Tractor

- Depress the clutch brake pedal, and pull on the parking brake knob. Remember that it takes a few seconds more for the moving parts of the tractor to come to a complete stop after the parking brake has been activated. Remove the key after the tractor is completely parked.

Setting Cutting Height

- Select the position for the tractor lift lever at the desired cutting height. Then move the wheels on the deck so that the wheels are 1/4 to 1/2 inch above the ground.

NOTE: To obtain uniform cut, the deck is designed to be suspended from the tractor at the desired cutting height. The deck wheels or the deck roller should be just off the ground for a smooth cut.

Operating Tractor

- Start the engine as instructed previously.
- Move throttle control to full throttle to prevent strain on the engine and to operate attachments.
- Place the shift lever in one of the two forward positions (LOW or HIGH), or in REVERSE. Place the speed control lever in desired position. Use LOW speed position when operating the tractor for the first time.



WARNING: Look to the rear of the tractor and check for obstructions before backing up.

- Depress the clutch-brake pedal to release the parking brake and put unit into motion.
- Depress the clutch-brake pedal to stop the unit.
- The cutting blades (or other attachment) may be engaged while the tractor is moving or standing still.

NOTE: Do *not* engage the cutting blades abruptly as the sudden belt tension on the pulley may cause the engine to stall.



WARNING: Keep hands and feet away from the discharge opening, the blades or any part of the deck.

NOTE: There will be little difference between the highest two speeds until after the belts have settled into the pulleys after the break-in period.

- Change oil in the engine crankcase after the first five hours of operation.
- Be sure that the lawn is clear of stones, sticks, wire, or other objects which could damage tractor or engine. For best results, do not mow when the lawn is too wet.

NOTE: By shutting off the engine before disembarking, you will also avoid the possibility of "browning" the grass. (The "browning" is caused when grass is exposed to hot exhaust gases from a running engine.)



WARNING: Before leaving the operator's position for any reason, disengage the blades, place the shift lever in neutral, engage the parking brake, shut engine off and remove key.

If unit stalls with speed control in sixth or seventh speed, or if the unit will not operate with speed control lever in the first or second speed position, follow instructions below:

- Place shift lever in NEUTRAL.
- Restart engine.
- Place speed control lever in highest speed position.
- Release clutch-brake pedal fully.
- Depress clutch-brake pedal.
- Place speed control lever in desired position.
- Place shift lever in one of the forward positions (HIGH or LOW) or REVERSE, and follow normal operating procedures.

High-Low Transmission Ranges

HIGH range position is for normal load conditions, such as mowing or transporting.

LOW range position is for high load conditions requiring more torque, such as tilling, snow removing or hauling heavy loads.

Grass Collector

Grass Collector Model OEM-190-083 is available as optional equipment for tractors with 46" mowing decks.



NOTE: The mower should not be operated without the entire grass catcher or chute deflector in place.

NOTE: Under normal usage, grass bag material is subject to wear, and should be checked periodically. Use only factory authorized replacement bag.

SECTION 7: MAKING ADJUSTMENTS



WARNING: Disconnect the spark plug wire(s) and ground against the engine before performing any adjustments, repairs or maintenance.

Leveling the Deck

The sides of the deck should be the same distance from the ground. The front of the deck should be 1/4" to 3/8" lower than the rear of the deck. If adjustment is required, refer to "Leveling the Deck" instructions in Assembly section of this manual.

Speed Control Adjustment

(See Figure 21)

NOTE: There will be little difference between the highest two speeds until after the belts have gone through a break-in period and have settled into the pulleys.

If speed control adjustment is needed, adjust the speed control links as follows. (A 3/4" shim or suitable spacer is required.)

- Start the engine. Place the shift lever in neutral position. Place the speed control lever in highest speed position.
- Release the clutch-brake pedal completely, then slowly depress the pedal all the way (to park position). Hold the pedal in this position.
- Turn the engine off.
- After engine stops completely, release the clutch-brake pedal.
- Remove the transmission cover by removing the parking brake knob, shift knob and two truss machine screws.
- Disconnect the rear speed control link from the variable speed torque bracket by removing the cotter pin and flat washer.

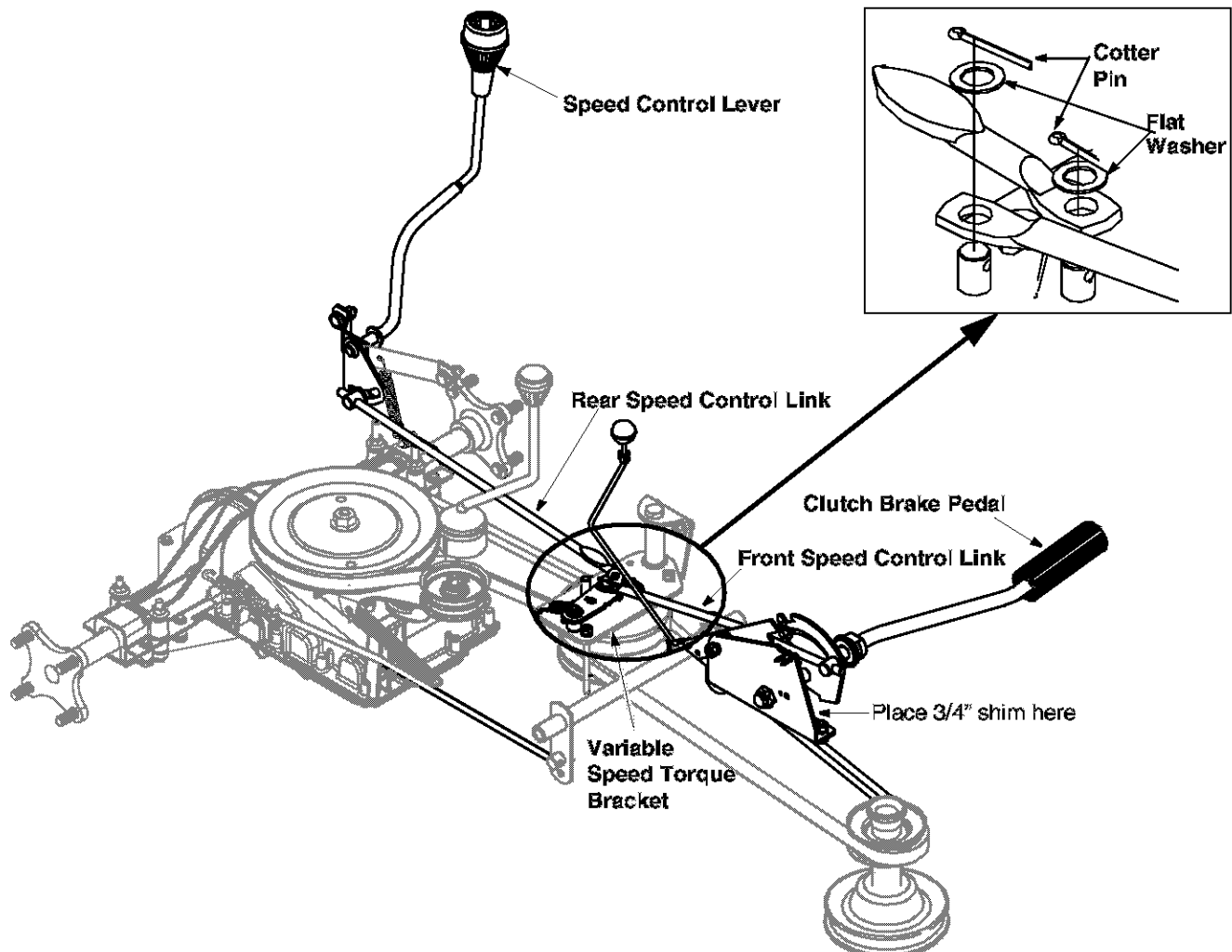

Figure 21

- **Models 820-829 only:** Place the speed control lever in the first position.
- **Models 840-849 only:** Place the speed control lever in the second position.
- Disconnect the front speed control link from the variable speed torque bracket by removing the cotter pin and flat washer.
- Place a 3/4" shim or other suitable object under the point on the bracket on the clutch-brake pedal as shown in Figure 21 .
- Thread the front speed control link in or out of the ferrule until the hole in the link lines up with the pin on the variable speed torque bracket. Secure with the flat washer and cotter pin removed earlier.
- Push the rear speed control link backward using light pressure, and hold it in this position as you thread it into or out of the ferrule until the hole in the link lines up with the pin on the variable speed torque bracket.
- **Models 820-829 only:** Turn the link three more times making it longer.
- Move the speed control lever toward the right so that the hole in rear speed control link fits over the pin on the variable speed torque bracket. Secure with the flat washer and cotter pin removed earlier.
- Remove the 3/4" shim from beneath the bracket on the clutch-brake pedal.

Quick Adjustment Seat

- To adjust the position of the seat, move the seat adjustment lever (located under the seat) to the left and slide the seat forward or backwards. See Figure 22. Make sure seat is locked into one of the six adjustment positions before operating the garden tractor.

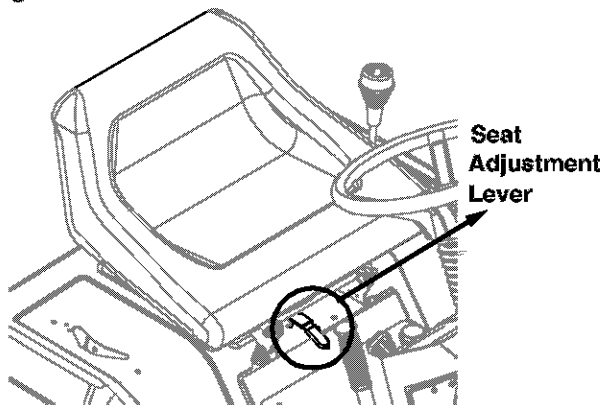

Figure 22

Manual Adjustment Seat

- To adjust the position of the seat, loosen the four screws on the bottom of the seat. Refer to Figure 4. Slide the seat forward or backward as desired. Retighten the four screws.

Steering Wheel

If the tractor turns tighter in one direction compared to the other, the steering drag link must be adjusted. To adjust the drag link follow these steps. See Figure 23.

- Loosen hex jam nut, called out in Figure 23 , at the rear of the ball joint.
- Loosen and remove hex nut.
- Lift the threaded portion of the ball joint out of the steering arm. Save the hardware used to hold ball joint to steering arm.
- Set the front wheels facing straight ahead.
- Turn the steering wheel to the right or the left to match the alignment holes in the steering brace and the steering gear.
- Once aligned, drop a nail through the steering brace and steering gear alignment holes.
- Adjust the ball joint in or out on the drag link until the threaded portion of the ball joint slips through the hole in the steering arm. Make sure the lock washer is in position between the ball joint and the steering arm.
- Tighten hex jam nut against the ball joint.
- Reattach the ball joint to the steering arm with hex nut. (Finger tighten only at this time.)
- Turn the steering wheel fully to the left and the right to make sure that the drag link does not touch any part of the tractor frame. If the drag link does touch the tractor frame, start at step 1 and redo the adjustment. Tighten hex nut.
- Remove the nail used to align the steering gear.

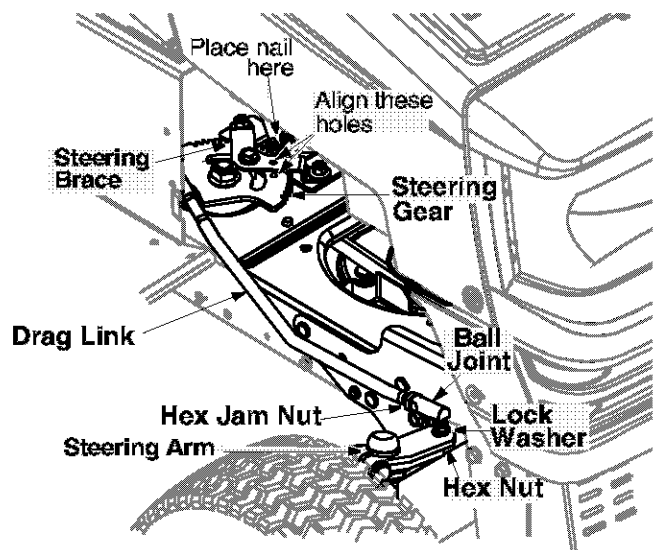

Figure 23

Brake

The brake is located on the right side of the transaxle. During normal operation, the brake is subject to wear and will require periodic examination and adjustment. To see if brake needs adjusting, proceed as follows.



WARNING: Do not adjust the brake while the engine is running. Be sure to block the wheels of the tractor before making the brake adjustment.

- Set the parking brake by depressing the clutch-brake pedal and pulling up the parking brake knob.
- Working on the right side of the tractor, try inserting a piece of paper through the coils of the brake spring. See Figure 24.
- If the paper **can** be inserted through the coils of the brake spring, the brake is properly adjusted.
- If the paper **cannot** be inserted, tighten hex lock nut until the paper goes through the coils.
- Release parking brake and place the tractor in neutral. Depress clutch-brake pedal and try rolling the tractor. The tractor should not move. If the tractor moves, repeat above steps until proper brake adjustment is reached.

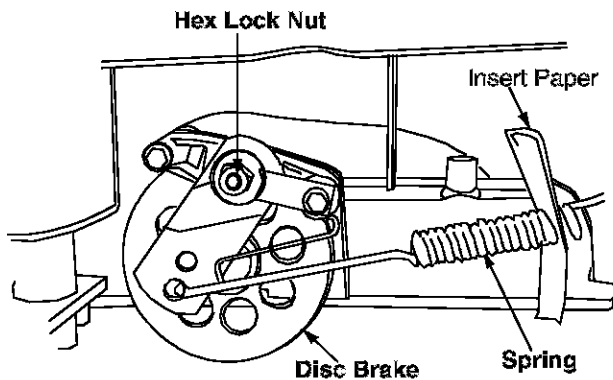
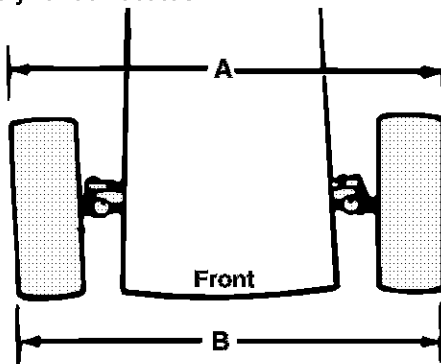

Figure 24

Wheel

The caster (forward slant of the king pin) and the camber (tilt of the wheels out at the top) require no adjustment. Automotive steering principles have been used to determine the caster and camber on the tractor. The front wheels should toe-in between 1/16-5/16 inch. Dimension "B" should be approximately 1/16-5/16" less than Dimension "A." See Figure 26. Adjust the tie rod assembly for correct toe-in.



(1/16" - 5/16" Less Than A)

Figure 25

Some units have adjustable tie rods so the toe-in can be adjusted. To adjust the toe-in on these units, follow these steps.

- Remove hairpin clip and washer, and drop the end of the tie rod from the axle bracket. See Figure 25.
- Loosen the hex jam nut on tie rod.
- To increase Dimension "B," screw the tie rod into the tie rod end. To decrease Dimension "B," unscrew the tie rod from the tie rod end.
- Reassemble tie rod. Check dimensions. Readjust if necessary.

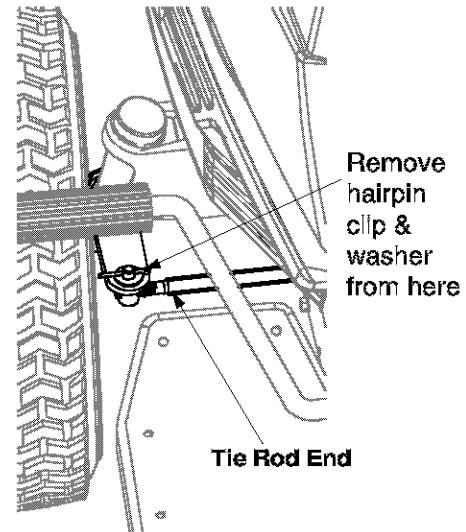

Figure 26

Carburetor



WARNING: If any adjustments are made to the engine while the engine is running (e.g. carburetor), disengage all clutches and blades. Keep clear of all moving parts. Be careful of heated surfaces and muffler.

Minor carburetor adjustments may be required to compensate for differences in fuel, temperature, altitude and load. Refer to the engine manual for carburetor adjustment information.

NOTE: A dirty air cleaner will cause an engine to run rough. Be certain air cleaner is clean and attached to the carburetor before adjusting carburetor.

SECTION 8: MAINTAINING YOUR GARDEN TRACTOR



WARNING: Disconnect the spark plug wire(s) and ground against the engine before performing any adjustments, repairs or maintenance.

Lubrication

Steering Gears

Lubricate teeth of steering gears with automotive multi-purpose grease after every 25 hours of operation or once a season. Refer to Figure 23.

Steering Shaft

Lubricate steering shaft at least once a season with light oil.

Transaxle

The transaxle is lubricated and sealed at the factory and does not require checking. If disassembled for any reason, lubricate with 32 oz. of Shell Darina grease, part number 737-0148 (10 oz. tube).

Linkage

Once a season lubricate all the pivot points on the clutch, brake and lift linkage with SAE 30 engine oil.

Wheels

Some models have front wheels with grease fittings. Lubricate at least once a season with automotive multi-purpose grease.

Pivot Points

Lubricate all pivot points with light oil at least once a season.

Ball Joints

The ball joints and drag link ends are permanently lubricated and do not need any further lubrication.

Blade Spindles

The blade spindles on the cutting deck are permanently lubricated and do not need any further lubrication.

Engine Maintenance

Refer to engine manual for maintenance instructions. A list of general recommendations is given below.

- Maintain **engine oil** as instructed in the engine manual. Read and follow instructions carefully.
- Service **air cleaner** every 25 hours under normal conditions. Clean every few hours under extremely dusty condition. To service air cleaner, refer to the engine manual.
- The **spark plugs** should be cleaned and the gap reset once a season. Spark plug replacement is recommended at the start of each mowing season; check engine manual for correct plug type and gap specifications.

Cutting Blades



WARNING: Protect hands by using heavy gloves or a rag to grasp the cutting blades.

The blades may be removed for sharpening or replacement as follows:

- Remove the hex flange nut that holds the blade to the blade spindle. See Figure 27.

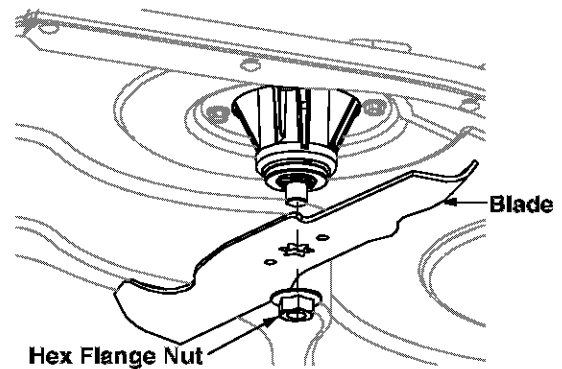

Figure 27

- When sharpening the blades, follow the original angle of grind as a guide. It is extremely important that each cutting edge be ground equally to prevent an unbalanced blade. An unbalanced blade will cause excessive vibration when rotating at high speeds, may cause damage to the tractor and could break, causing personal injury.
- The blade can be tested for balance by balancing it on a round shaft screwdriver. Remove metal from the heavy side until it balances evenly.
- When replacing the blade, be sure to install the blade with the side of the blade marked "Bottom" (or with part number) facing the ground when the tractor is in the operating position.

Torque Specifications

Blade: Hex Fl. Nut 840 in. lb. min., 1080 in. lb. max.

Blade Spindle Screws: If disassembled for any reason, tighten the blade spindle screws to between 200 and 275 inch pounds.

Battery Care

Type "A" Battery

Type "A" batteries are sealed and maintenance-free.

Type "B" Battery

- Check fluid level inside each cell of the battery every two weeks and before and after charging. Always maintain level just below the split rings.

- Add only distilled water. Never add additional acid or any other chemicals to the battery after initial activation.

NOTE: If you have operated the tractor for a long period, check the fluid level of the battery as it can overheat and lose fluid.

Charging Battery

The engine is equipped with an alternator which charges the battery while the tractor is running. Under normal conditions, the battery only needs to be charged before, during and after off-season storage. Follow the instructions under "Off-Season Storage."

- To charge the battery, follow the chart below.

Battery Part Number	Charging Duration	Amperes
725-1705D	1 Hour	2-3
725-1707D	1 Hour	6
725-0453G	1 Hour	6
725-1750	1 Hour	6
725-1706	1 Hour	6

Removing / Re-Installing Battery



WARNING: When removing or installing the battery, follow these instructions to prevent the screwdriver from shorting against the frame.

- **Removing the Battery:** Disconnect negative cable first, then positive cable.
- **Installing the Battery:** Connect positive cable first, then negative cable.

Jump Starting

- First, connect end of one jumper cable to the positive terminal of the good battery, then the other end to the positive terminal of the dead battery.
- Connect the other jumper cable to the negative terminal of the good battery, then to the frame of the unit with the dead battery.



WARNING: Failure to follow these instructions in the correct order could cause sparking, and the gas in either battery could explode.

Clean the Battery

Clean the battery by removing it from the unit and washing with a baking soda and water solution. If necessary, scrape the battery terminals with a wire brush to remove deposits. Coat terminals and exposed wiring with grease or petroleum jelly to prevent corrosion.

Battery Failures

Common causes for battery failure are: initial activation not done correctly, lack of water, adding chemicals other than water after initial activation, undercharging, overcharging, corroded connections, freezing. **These failures do not constitute warranty work.**

Tires

- Maximum tire pressure under any circumstance is 30 p.s.i. Equal tire pressure should be maintained on all tires. Check tire sidewalls for manufacturer's recommendation on tire inflation.
- When installing a tire to the rim, make sure that the rim is clean and free of rust. Lubricate both the tire and the rim generously. Never inflate beyond manufacturer's recommendation.



WARNING: Excessive pressure (over 30 p.s.i.) when seating beads may cause tire/rim assembly to burst with force sufficient to cause serious injury.

Cleaning Engine & Deck

- Any fuel or oil spilled on the machine should be wiped off promptly. Grass, leaves, and other dirt must not be allowed to accumulate around the cooling fins of the engine or on any part of the machine. Clean the underside of the deck after each mowing.

NOTE: We do not recommend the use of pressure washers or garden hose to clean your unit. They may cause damage to electric components, spindles, pulleys, bearings or the engine. The use of water will result in shortened life and reduce serviceability.

Fuel Filter

- Your unit is equipped with a replaceable in-line fuel filter. Replace filter whenever contamination or discoloration is noticed. Order replacement filter through an authorized engine service dealer.

Belt Replacement

Deck Belt

- Remove the deck from the tractor following instructions on pages 10-12 in reverse order.

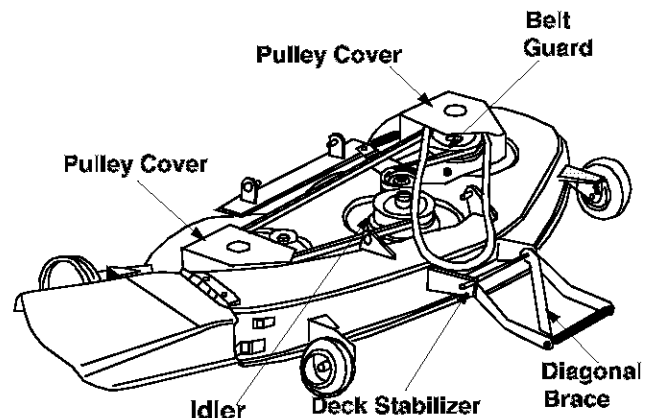

Figure 28

- Remove the left hand pulley cover by unhooking the spring and removing five self-tapping screws. See Figure 28.
- Remove the first drive belt.
- Remove the right hand pulley cover by removing three self-tapping screws.
- Pivot the spring-loaded idler and lift the belt. Remove the belt from around the three deck pulleys.
- Reassemble new belts in reverse order.

Front Drive Belt

- Depress the clutch pedal and set parking brake.
- Remove the deck from the tractor.

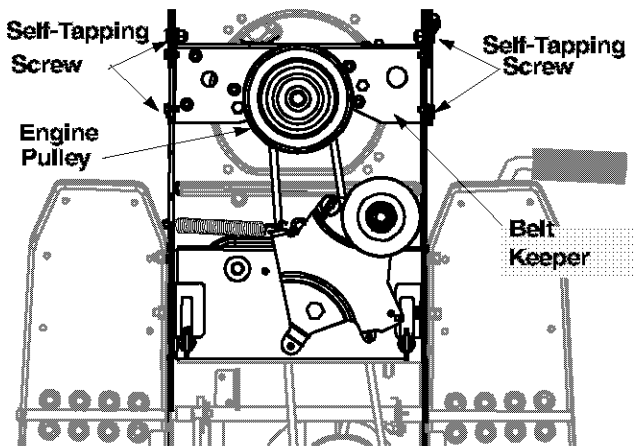

Figure 29

- Raise and block the front wheels of the tractor.
- Remove the four self-tapping screws which hold the belt keeper assembly to the frame at the engine pulley. Push the belt keeper assembly forward and out of the way. See Figure 29.

- Remove the two pins which act as belt keepers by the variable speed pulley. For the location of the variable speed pulley, see Figure 30.
- Roll the belt off the variable speed pulley, then remove from the engine pulley.
- Reassemble the new belt.

Rear Drive Belt

- First remove the front drive belt as instructed in the previous section.
- Disconnect the spring which secures the idler pulley to the frame. See Figure 30.
- Remove the transmission cover by unscrewing the two knobs and removing two machine screws.
- Roll the belt over the top of the transmission pulley. Remove belt from the variable speed pulley.
- Reassemble the new belt.

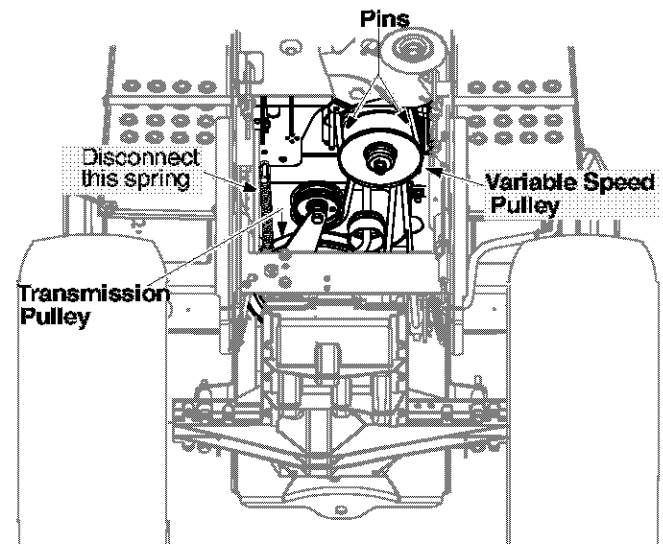

Figure 30

SECTION 9: OFF-SEASON STORAGE

If the machine is to be inoperative for a period longer than 30 days, prepare for storage as follows.

- Clean the engine and the entire unit thoroughly.

NOTE: We do not recommend the use of pressure washers or garden hose to clean your unit. They may cause damage to electric components, spindles, pulleys, bearings or the engine. The use of water will result in shortened life and reduce serviceability.

- Lubricate all lubrication points. Wipe the entire machine with an oiled rag to protect the surfaces.
- Refer to the engine manual for correct engine storage instructions. The engine must be completely drained of fuel and a fuel stabilizer used to prevent gum deposits from forming on essential carburetor parts, fuel lines and fuel tanks.

- Charge the battery fully. Remember that the battery loses some of its charge each day when the unit is not used. NEVER store battery without a full charge. Recharge battery before returning to service or every two months, whichever occurs first.
- When storing unit for extended periods, disconnect battery cables. Removing battery from unit is recommended.
- Store unit in a clean, dry area. Do not store next to corrosive materials, such as fertilizer.

NOTE: When storing any type of power equipment in an unventilated or metal storage shed, care should be taken to rustproof the equipment. Using a light oil or silicone, coat the equipment, especially any chains, springs, bearings and cables.

SECTION 10: OPTIONAL EQUIPMENT

At the time of manufacture of tractor, the following optional equipment is available.

Description	Model No.
• Grass Collector For 46" Deck	• OEM-190-083
• Mulching Kit For 46" Deck	• OEM-190-118
• 45" Two Stage Snow Thrower	• OEM-190-624
• 48" Dozer Blade	• OEM-190-840
• 42" Rear Dozer Blade**	• OEM-190-804
• Agricultural Traction Tires	• OEM-190-865
• Tire Chains—23 x 9.5	• OEM-190-964
• 100 lb. Wheel Weights	• OEM-190-784
• Front Bumper Kit	• OEM-190-226
• Sleeve Hitch Kit	• OEM-190-929
• 28" PTO Driven Rear Mounted Tiller	• OEM-190-757
• 38" 8 HP Rear Mounted Tiller	• OEM-190-758
• Electric Lift Kit	• OEM-190-749
• 10" Moldboard Plow**	• OEM-190-978
• Single Disc Harrow**	• OEM-190-980
• Row Crop Cultivator**	• OEM-190-984
• Gang Reel (Set of three)*	• 45-0195
• 38" Lawn Sweeper*	• 45-0222
• Heavy Duty Lawn Roller*	• 45-0179
• Heavy Duty Dump Cart*	• 45-0171
• Tine De-Thatcher*	• 45-0186

* Available through your local dealer or from Agri-Fab Inc.,
303 W. Raymond Street, Sullivan, Illinois 61951

**Sleeve Hitch Required (OEM-190-929)

SECTION 11: TROUBLE SHOOTING

Trouble	Possible Cause(s)	Corrective Action
Engine will not crank	<ol style="list-style-type: none"> 1. Safety switch button not depressed. 2. Battery installed incorrectly. 3. Battery is dead or weak. 4. Blown fuse or circuit breaker. 5. Engine ground wire loose. 	<ol style="list-style-type: none"> 1. There are two switches in the starting circuit of your unit: the clutch pedal switch and the deck lift lever switch. Make certain the actuator is fully depressing the buttons on each switch. 2. The battery must be installed with negative terminal attached to black ground wire. Negative terminal is identified at the post by "NEG", "N" or "-". The positive terminal, identified by "POS", "P" or "+", must be attached to the big red wire which goes to the solenoid. All batteries are to be fully charged before installing. Refer to "Quick Start" battery guide that came with the operator's manual. 3. Check fluid level in battery. If fluid is low, fill to just below split rings with water. Charge with 6 AMP charger until the battery is fully charged. 4. Refer to the illustrated parts list for fuse box location. Replace fuse with automotive type fuse. Fuses seldom fail without a reason. The problem must be corrected. Check for loose connections in the fuse holder. Replace fuse holder if necessary. A dead short may be in the cranking or charging circuit where the insulation may have rubbed through and exposed the bare wire. Replace the wire or repair with electrician's tape if the wire strands have not been damaged. Note: Look for a wire pinched between body panels, burned by the exhaust pipe or muffler or rubbed against a moving part. 5. Engine should have a black ground wire running from engine to frame or mounting bolt.
Engine cranks but will not start	<ol style="list-style-type: none"> 1. Throttle or choke not in starting position 2. No fuel to the carburetor 3. Fuel line or in-line fuel filter plugged 4. Spark plug lead disconnected 5. Faulty spark plug 6. Dirty air cleaner 	<ol style="list-style-type: none"> 1. Check operator's manual for correct position for throttle control and choke for starting. 2. Gasoline tank empty. Fill tank. 3. Remove and clean fuel line. Replace filter if necessary. 4. Connect lead. Hold spark plug lead away from engine block about 1/8". Crank engine. There should be a spark. If not, have engine repaired at authorized engine service dealer. 5. To test, remove spark plug. Attach spark plug lead to spark plug. Ground the spark plug body against the engine block. Crank the engine. The spark plug should fire at the electrode. Replace if it does not. 6. Refer to the engine manual.
Engine smokes	<ol style="list-style-type: none"> 1. Engine oil has been overfilled. 2. Dipstick not seated and/or broken. 3. Engine loses crankcase vacuum. 	<ol style="list-style-type: none"> 1. Check oil level. 2. Re-insert dipstick properly. Replace defective part if needed. 3. Engine breather defective. Replace following engine manual.
Excessive vibration	<ol style="list-style-type: none"> 1. Loose bolt or part. 2. Bent or damaged blade. 	<ol style="list-style-type: none"> 1. Stop engine immediately. Check all pulleys, blade adapters, keys and bolts for tightness and spindle damage. Tighten or replace any damaged parts. 2. Replace blade following instruction in this manual.
Mower will not discharge grass or leaves uncut strips	<ol style="list-style-type: none"> 1. Engine speed low. 2. Speed selection. 3. Cutting height set too low. 4. Blades short or dull. 	<ol style="list-style-type: none"> 1. Throttle must be set at full throttle. 2. Use lower ground speed. 3. Raise deck. 4. Sharpen or replace blades (uncut strip problem only).

YOUR NOTES

Date	Comments

MANUFACTURER'S LIMITED WARRANTY FOR:



The limited warranty set forth below is given by MTD LLC with respect to new merchandise purchased and used in the United States, its possessions and territories.

MTD LLC warrants this product against defects for a period of two (2) years commencing on the date of original purchase and will, at its option, repair or replace, free of charge, any part found to be defective in materials or workmanship. This limited warranty shall only apply if this product has been operated and maintained in accordance with the Operator's Manual furnished with the product, and has not been subject to misuse, abuse, commercial use, neglect, accident, improper maintenance, alteration, vandalism, theft, fire, water, or damage because of other peril or natural disaster. Damage resulting from the installation or use of any accessory or attachment not approved by MTD LLC for use with the product(s) covered by this manual will void your warranty as to any resulting damage.

Normal wear parts or components thereof are subject to separate terms as follows: All normal wear parts or component failures will be covered on the product for a period of 90 days regardless of cause. After 90 days, but within the two year period, normal wear part failures will be covered ONLY IF caused by defects in materials or workmanship of OTHER component parts. Normal wear parts and components include, but are not limited to: batteries, belts, blades, blade adapters, grass bags, rider deck wheels, seats, snow thrower skid shoes, shave plates, auger spiral rubber, and tires.

HOW TO OBTAIN SERVICE: Warranty service is available, WITH PROOF OF PURCHASE, through your local authorized service dealer. To locate the dealer in your area, check your Yellow Pages, or contact MTD LLC at P.O. Box 361131, Cleveland, Ohio 44136-0019, or call 1-800-800-7310 or 1-330-220-4683 or log on to our Web site at www.mtdproducts.com.

This limited warranty does not provide coverage in the following cases:

- a. The engine or component parts thereof. These items carry a separate manufacturer's warranty. Refer to applicable manufacturer's warranty for terms and condition.
- b. Log splitter pumps, valves, and cylinders have a separate one year warranty.
- c. Routine maintenance items such as lubricants, filters, blade sharpening, tune-ups, brake adjustments, clutch adjustments, deck adjustments, and normal deterioration of the exterior finish due to use or exposure.

- d. MTD LLC does not extend any warranty for products sold or exported outside of the United States, its possessions and territories, except those sold through MTD LLC's authorized channels of export distribution.
- e. Parts that are not genuine MTD parts are not covered by this warranty.
- f. Service completed by someone other than an authorized service dealer is not covered by this warranty.
- g. Transportation charges and service calls are not covered.

No implied warranty, including any implied warranty of merchantability of fitness for a particular purpose, applies after the applicable period of express written warranty above as to the parts as identified. No other express warranty, whether written or oral, except as mentioned above, given by any person or entity, including a dealer or retailer, with respect to any product, shall bind MTD LLC. During the period of the warranty, the exclusive remedy is repair or replacement of the product as set forth above.

The provisions as set forth in this warranty provide the sole and exclusive remedy arising from the sale. MTD LLC shall not be liable for incidental or consequential loss or damage including, without limitation, expenses incurred for substitute or replacement lawn care services or for rental expenses to temporarily replace a warranted product.

Some states do not allow the exclusion or limitation of incidental or consequential damages, or limitations on how long an implied warranty lasts, so the above exclusions or limitations may not apply to you.

In no event shall recovery of any kind be greater than the amount of the purchase price of the product sold. **Alteration of safety features of the product shall void this warranty.** You assume the risk and liability for loss, damage, or injury to you and your property and/or to others and their property arising out of the misuse or inability to use the product.

This limited warranty shall not extend to anyone other than the original purchaser or to the person for whom it was purchased as a gift.

HOW STATE LAW RELATES TO THIS WARRANTY: This limited warranty gives you specific legal rights, and you may also have other rights which vary from state to state.