

OPERATOR'S MANUAL

**Model Series
060**

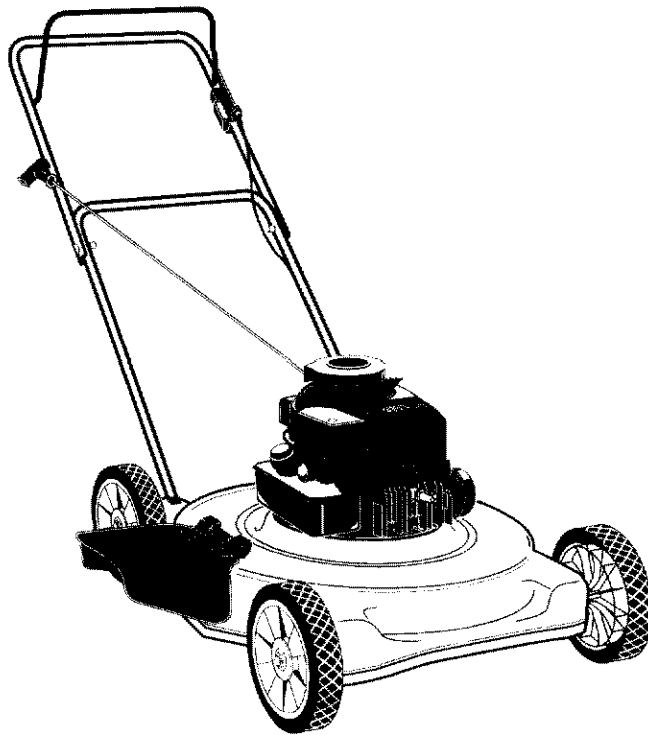

IMPORTANT: READ SAFETY RULES AND INSTRUCTIONS CAREFULLY

Warning: This unit is equipped with an internal combustion engine and should not be used on or near any unimproved forest-covered, brush-covered or grass-covered land unless the engine's exhaust system is equipped with a spark arrester meeting applicable local or state laws (if any). If a spark arrester is used, it should be maintained in effective working order by the operator. In the State of California the above is required by law (Section 4442 of the California Public Resources Code). Other states may have similar laws. Federal laws apply on federal lands. A spark arrester for the muffler is available through your nearest engine authorized service dealer or contact the service department, P.O. Box 368022 Cleveland, Ohio 44136-9722.

MTD PRODUCTS INC. P.O. BOX 368022 CLEVELAND, OHIO 44136-9722

SECTION 1: FINDING YOUR MODEL NUMBER

This Operator's Manual is an important part of your new walk behind. It will help you assemble, prepare and maintain your walk behind. Please read and understand what it says.

Before you start to prepare your walk behind for its first use, please locate the model plate and copy the information from it in this Operator's Manual. The information on the model plate is very important if you need help from your dealer or the MTD customer support department.

- Every walk behind has a model plate. You can locate it by standing behind the unit in the operating position and looking down at the rear of the deck. See Figure 1.

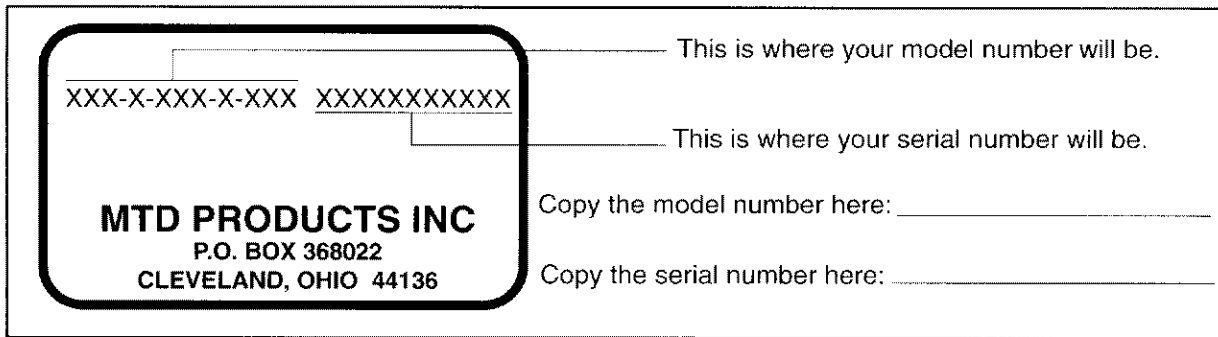

Figure 1

SECTION 2: CALLING CUSTOMER SUPPORT

- **LOCATE YOUR MODEL NUMBER AND SERIAL NUMBER** — Record this information in the space provided. To find your unit's specific model number and serial number, see SECTION 1: FINDING YOUR MODEL NUMBER.
- If you are having difficulty assembling this product or if you have any questions regarding the controls, operation or maintenance of this unit, please call the Customer Support Department.
- Customer Support can be reached by dialing: **1- (330) 220-4MTD (4683)**
or
1- (800)-800-7310
- Please have your model number and serial number ready when you call.
- Although both numbers are important, you will be asked to enter only your **serial** number before your call can be processed.

SECTION 3: IMPORTANT SAFE OPERATION PRACTICES



WARNING: THIS SYMBOL POINTS OUT IMPORTANT SAFETY INSTRUCTIONS WHICH, IF NOT FOLLOWED, COULD ENDANGER THE PERSONAL SAFETY AND/OR PROPERTY OF YOURSELF AND OTHERS. READ AND FOLLOW ALL INSTRUCTIONS IN THIS MANUAL BEFORE ATTEMPTING TO OPERATE YOUR LAWN MOWER. FAILURE TO COMPLY WITH THESE INSTRUCTIONS MAY RESULT IN PERSONAL INJURY. WHEN YOU SEE THIS SYMBOL, HEED ITS WARNING.



WARNING: The Engine Exhaust from this product contains chemicals known to the State of California to cause cancer, birth defects or other reproductive harm.



DANGER: Your lawn mower was built to be operated according to the rules for safe operation in this manual. As with any type of power equipment, carelessness or error on the part of the operator can result in serious injury. This lawn mower is capable of amputating hands and feet and throwing objects. Failure to observe the following safety instructions could result in serious injury or death.

1. GENERAL OPERATION

- Read this operator's manual carefully in its entirety before attempting to assemble this machine. Read, understand, and follow all instructions on the machine and in the manual(s) before operation. Be completely familiar with the controls and the proper use of this machine before operating it. Keep this manual in a safe place for future and regular reference and for ordering replacement parts.
- Your rotary mower is a precision piece of power equipment, not a plaything. Therefore, exercise extreme caution at all times. Your unit has been designed to perform one job: to mow grass. Do not use it for any other purpose.
- Never allow children under 14 years old to operate a power mower. Children 14 years old and over should only operate mower under close parental supervision. Only responsible individuals who are familiar with these rules of safe operation should be allowed to use your mower.
- Keep the area of operation clear of all persons, particularly small children and pets. Stop engine when they are in the vicinity of your mower to help prevent blade contact or thrown object injury. Although the area of operation should be completely cleared of foreign objects, an object may have been overlooked and could be accidentally thrown by the mower in any direction and cause serious personal injury to the operator or any others allowed in the area.
- Wear sturdy, rough-soled work shoes and close-fitting slacks and shirts. Shirts and pants that cover the arms and legs and steel-toed shoes are recommended. Do not wear loose fitting clothes or jewelry. They can be caught in moving parts. Never operate a unit in bare feet, sandals, slippery or light weight (e.g. canvas) shoes.
- Always wear safety glasses or safety goggles during operation or while performing an adjustment or repair, to protect eyes from foreign objects that may be thrown from the machine in any direction.
- Thoroughly inspect the area where the equipment is to be used. Remove all stones, sticks, wire, bones, toys and other foreign objects which could be picked up and thrown by the mower in any direction and cause serious personal injury to the operator or any others allowed in the area. Plan your mowing pattern to avoid discharge of material toward roads, sidewalks, bystanders and the like. To help avoid a thrown objects injury, keep children, bystanders and helpers at least 75 feet from the mower while it is in operation.
- Do not put hands or feet near or under rotating parts. Keep clear of discharge opening at all times as the rotating blade can cause injury.
- Many injuries occur as a result of the mower being pulled over the foot during a fall. Do not hang on to the mower if you are falling; release the handle immediately.
- Never pull the mower toward you while you are walking. If you must back the mower away from a wall or obstruction first look down and behind, and then follow these steps:
 - Step back from the mower to fully extend your arms.
 - Be sure you are well balanced with sure footing.
 - Pull the mower back slowly, no more than half way toward you.
 - Repeat these steps as needed.
- Do not operate the mower while under the influence of alcohol or drugs.

- Do not engage the self-propelled mechanism on units so equipped while starting engine.
- The blade control handle is a safety device. Never attempt to bypass its operation. Doing so makes the safety device inoperative and may result in personal injury through contact with the rotating blade. The blade control handle must operate easily in both directions and automatically return to the disengaged position when released.
- Never operate the mower in wet grass. Always be sure of your footing. A slip and fall can cause serious personal injury. Keep a firm hold on the handle and walk, never run. If you feel you are losing your footing, **RELEASE THE BLADE CONTROL HANDLE IMMEDIATELY** and the blade will stop rotating within three seconds.
- Mow only in daylight or good artificial light.
- Stop the blade when crossing gravel drives, walks or roads.
- If the equipment should start to vibrate abnormally, stop the engine and check immediately for the cause. Vibration is generally a warning of trouble.
- Shut the engine off and wait until the blade comes to a complete stop before removing the grass catcher or unclogging the chute. The cutting blade continues to rotate for a few seconds after the engine is shut off. Never place any part of the body in the blade area until you are sure the blade has stopped rotating.
- Never operate mower without proper guards, grass catcher, plates or other safety protective devices in place.
- Muffler and engine become hot and can cause a burn. Do not touch.
- Only use accessories approved for this machine by the manufacturer. Read, understand, and follow all instructions provided with the approved accessory.
- If situations occur which are not covered in this manual, use care and good judgment. Contact your dealer for assistance. Telephone 1-800-800-7310 for the name of your nearest dealer.

2. SLOPE OPERATION

For your safety, use the slope gauge included as part of this manual to measure slopes before operating this unit on a sloped or hilly area. If the slope is greater than 15 degrees as shown on the slope gauge, do not operate this unit on that area or serious injury could result.

DO:

- Mow across the face of slopes; never up and down. Exercise extreme caution when changing direction on slopes.
- Watch for holes, ruts, hidden objects, or bumps. Tall grass can hide obstacles.

- Always be sure of your footing. A slip and fall can cause serious personal injury. If you feel you are losing your balance release the blade control handle immediately and the blade will stop in less than 3 seconds.

DO NOT:

- Do not mow near drop-offs, ditches or embankments. The operator could lose footing or balance.
- Do not mow slopes greater than 15 degrees as shown on the slope gauge.
- Do not mow on wet grass. Reduced footing could cause slipping.

3. CHILDREN

Tragic accidents can occur if the operator is not alert to the presence of children. Children are often attracted to the mower and the mowing activity. Never assume that children will remain where you last saw them.

- Keep children out of the mowing area and under the watchful care of a responsible adult other than the operator.
- Be alert and turn mower off if a child enters the area.
- Before and while moving backwards, look behind and down for small children or other objects.
- Never allow children under age 14 to operate the mower. Children 14 years of age and above should read and understand the operation instructions and safety rules in this manual.
- Use extreme care when approaching blind corners, shrubs, trees, or other objects that may obscure your vision of a child or hazard.

4. SERVICE

- Use extreme care in handling gasoline and other fuels. They are extremely flammable and the vapors are explosive.
- Use only an approved gasoline container.
- Never remove gas cap or add fuel while the engine is running. Allow engine to cool at least two minutes before refueling.
- Replace gasoline cap securely and wipe off any spilled gasoline before starting the engine as it may cause a fire or explosion.
- Extinguish all cigarettes, cigars, pipes and other sources of ignition.
- Never refuel machine indoors because flammable vapors will accumulate in the area.
- Never store the machine or fuel container inside where there is an open flame or spark such as a gas water heater, space heater, or furnace.
- Never run an engine inside a closed area.

- To reduce fire hazard, keep mower free of grass, leaves, or other debris build-up. Clean up oil or fuel spillage. Allow mower to cool at least 5 minutes before storing.
- Before cleaning, repairing, or inspecting, make certain the blade and all moving parts have stopped. Disconnect the spark plug wire, and keep the wire away from the spark plug to prevent accidental starting.
- Check the blade and engine mounting bolts at frequent intervals for proper tightness. Also, visually inspect blade for damage (e.g., bent, cracked or worn). Replace with blade which meets original equipment specifications listed in this manual.
- Keep all nuts, bolts, and screws tight to be sure the equipment is in safe working condition.
- Never tamper with safety devices. Check their proper operation regularly.
- After striking a foreign object, stop the engine, remove the wire from the spark plug, and thoroughly inspect the mower for any damage. Repair the damage before starting and operating the mower.
- Never attempt to make a wheel or cutting height adjustment while the engine is running.
- Grass catcher components are subject to wear, damage and deterioration, which could expose moving parts or allow objects to be thrown. For safety protection, frequently check components and replace with manufacturer's recommended parts, when necessary.
- Mower blades are sharp and can cut. Wrap the blade(s) or wear gloves, and use extra caution when servicing them.
- Do not change the engine governor setting or overspeed the engine. Excessive engine speeds are dangerous.



WARNING - YOUR RESPONSIBILITY: Restrict the use of this power machine to persons who read, understand and follow the warnings and instructions in this manual and on the machine.



Figure 2 Safety Labels Found On Lawn Mower

USE THIS PAGE AS A GUIDE TO DETERMINE SLOPES WHERE YOU MAY NOT OPERATE SAFELY.

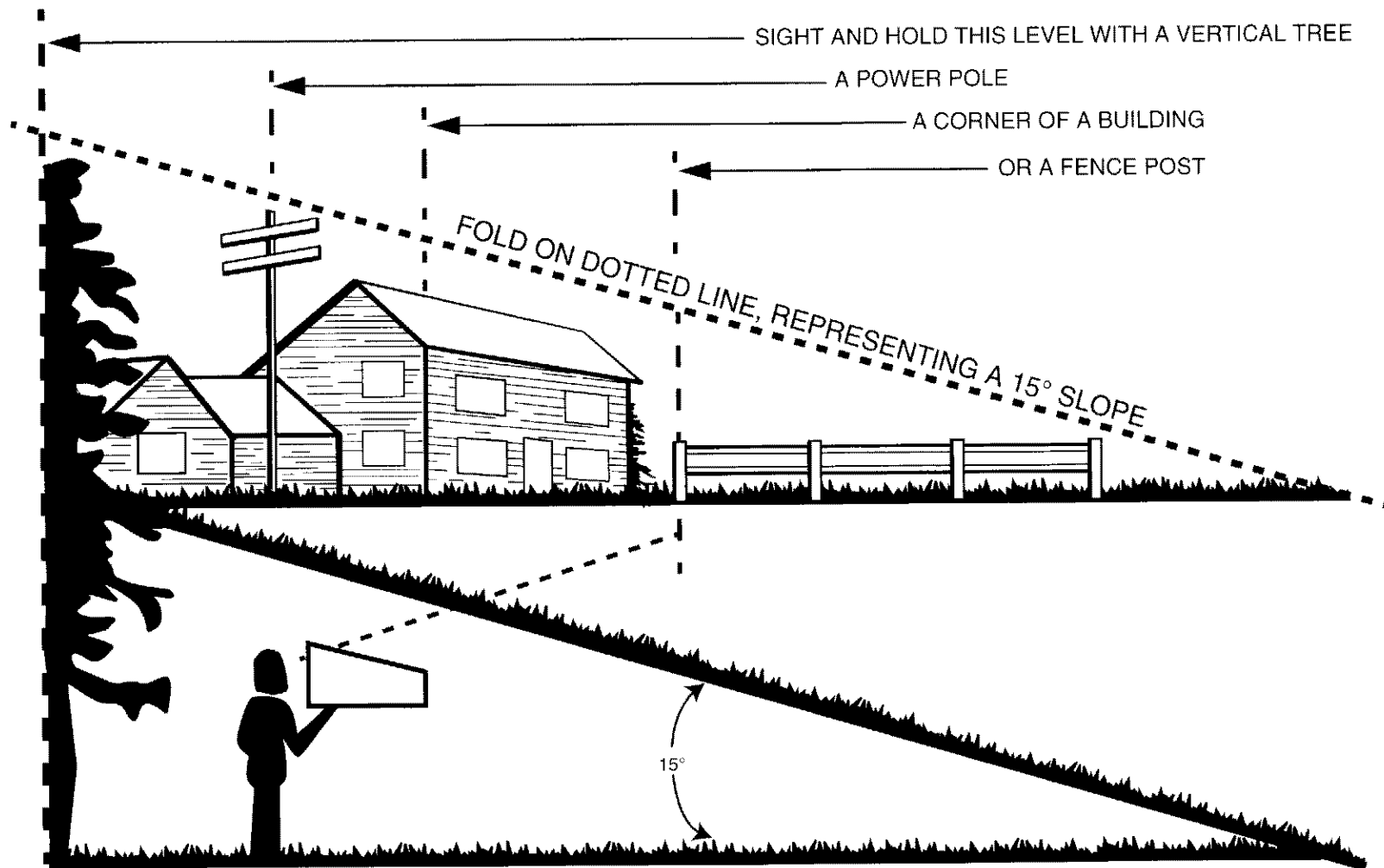

SECTION 4: SLOPE GAUGE



WARNING

Do not mow on inclines with a slope in excess of 15 degrees (a rise of approximately 2-1/2 feet every 10 feet). A riding mower could overturn and cause serious injury. If operating a walk-behind mower on such a slope, it is extremely difficult to maintain your footing and you could slip, resulting in serious injury.

Operate RIDING mowers up and down slopes, never across the face of slopes.

Operate WALK-BEHIND mowers across the face of slopes, never up and down slopes.

SECTION 5: CONTENTS OF HARDWARE PACK

Remove this sheet from your operator's manual and lay the hardware on the illustration for identification purposes. After Assembly, keep the Slope Gauge which is on the reverse side of this sheet for future use.
 (Hardware pack may contain extra items which are not used on your unit. Part numbers are shown in parentheses.)

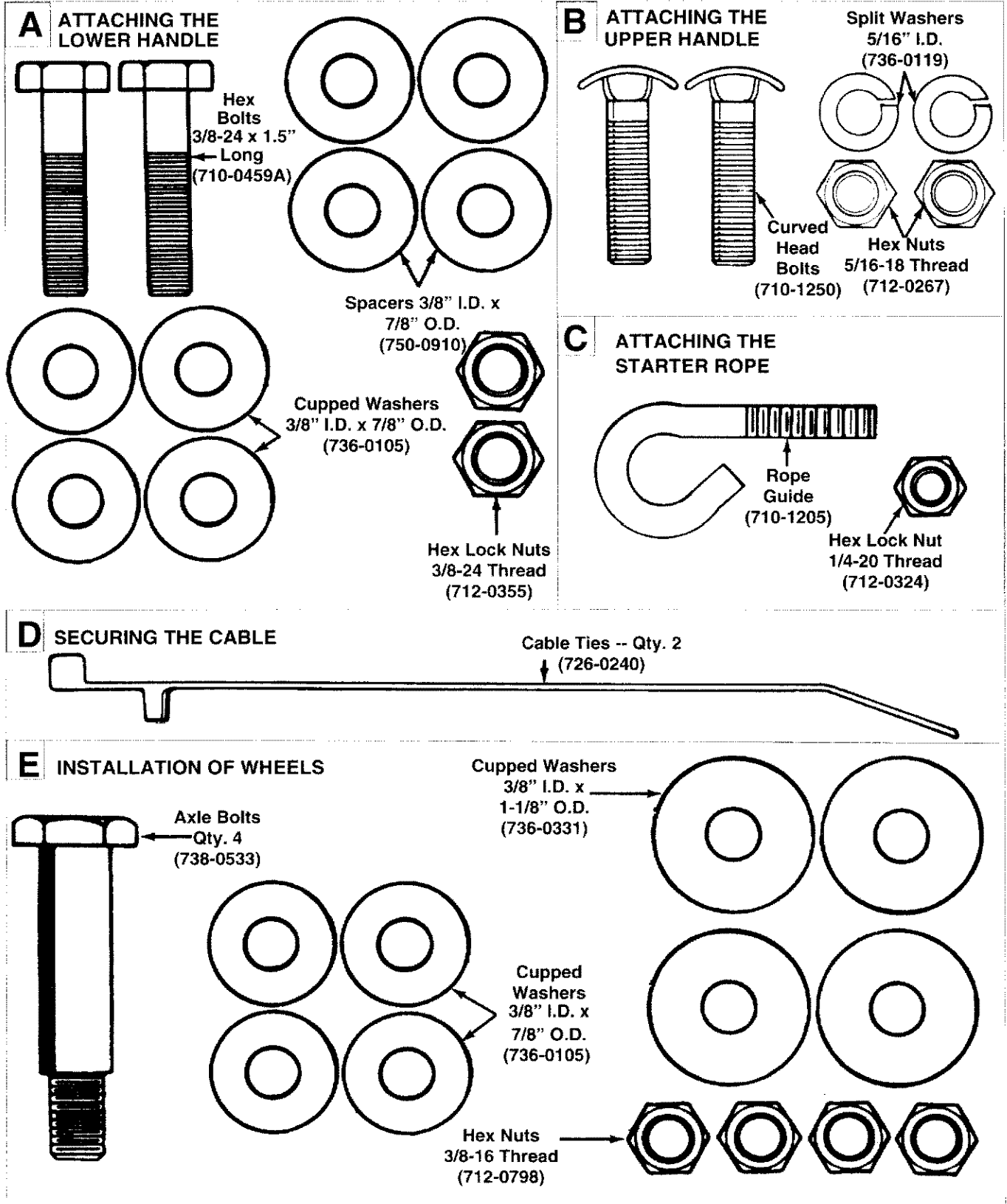

SECTION 6: UNPACKING TO REMOVE UNIT FROM CARTON

- Remove staples, break glue on top flaps, or cut tape at carton end and peel along top flap to open.
- Remove loose parts if included with unit (i.e., operator's manual, etc.).
- Cut along dotted lines and lay carton down flat.
- Remove packing material.
- Slide unit out of carton. Check carton thoroughly for loose parts.

TOOLS REQUIRED FOR ASSEMBLY

- (1) 1/2" Wrench
- (2) 9/16" Wrenches
- (1) Phillips Screwdriver
- (1) 3/4" or Adjustable Wrench
- (Two 6" Adjustable Wrenches may be used instead of the above.)

DISCONNECT SPARK PLUG WIRE

Before setting up your lawn mower, disconnect the spark plug wire from the spark plug, and ground it against the engine. See Figure 3.

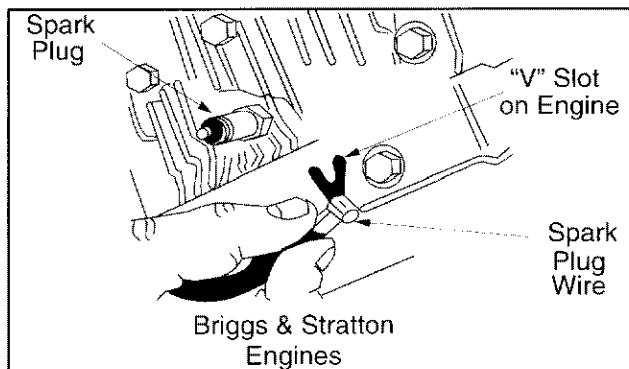

Figure 3

SECTION 7: ASSEMBLY INSTRUCTIONS

IMPORTANT: This unit is shipped WITHOUT GASOLINE or OIL. After assembly, service engine with gasoline and oil as instructed in the separate engine manual packed with your unit.

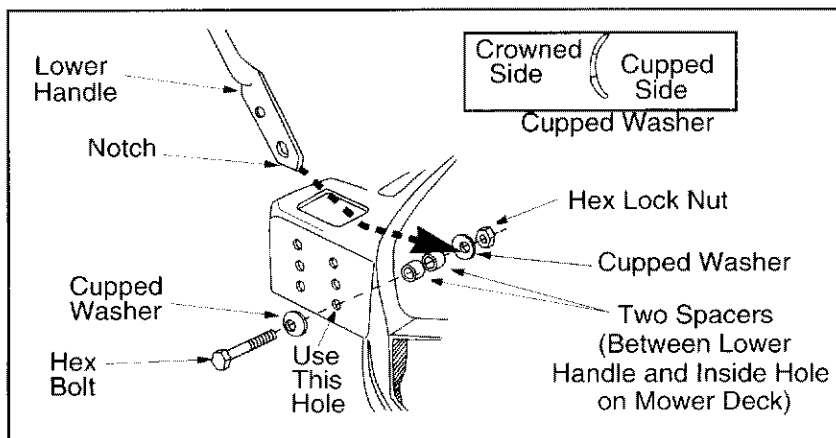

Figure 4

ATTACHING THE LOWER HANDLE (Hardware A)

- Raise the rear of the deck and block securely.
- Place one cupped washer on each hex bolt 1-1/2" long (crowned side of washer goes against the head of the hex bolt).
- Insert the ends of the lower handle through the slots in the rear of the deck.

NOTE: It is helpful to have another person hold the handle in position as you continue.

- Place **two** spacers between the bottom hole in lower handle and **bottom inside hole** of the deck. See Figure 4. Use a screwdriver to pry the handle away from the deck if necessary.
- Using a screwdriver, line up the bottom inside hole in the deck, the spacers and the bottom hole in the handle, then insert hex bolt as shown from the outside of the deck.
- Secure with cupped washer (cupped side against the handle) and hex lock nut. Do not tighten at this time.
- Repeat steps 4 through 6 to attach the other side of the handle.
- Tighten both hex bolts and nuts securely.

ATTACHING THE UPPER HANDLE (Hardware B)

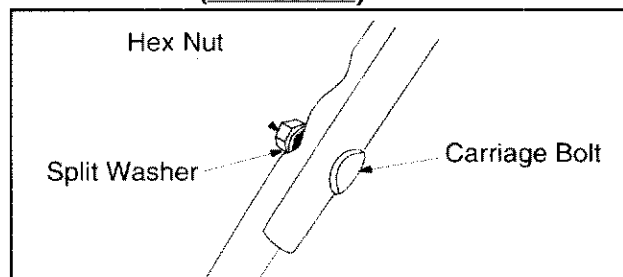

Figure 5

- Place the upper handle in position over the lower handle. The hole in the side of the blade control handle (attached to the upper handle) must be on the **left** side.
- Secure the upper handle to lower handle using the carriage bolts, split washers and hex nuts as shown in Figure 5. The head of the carriage bolts go on the outside of the handle.

ATTACHING THE CONTROL BOX

One end of the brake cable is attached to the engine. The other end is attached to the control box. Attach the control box to the upper handle as follows.

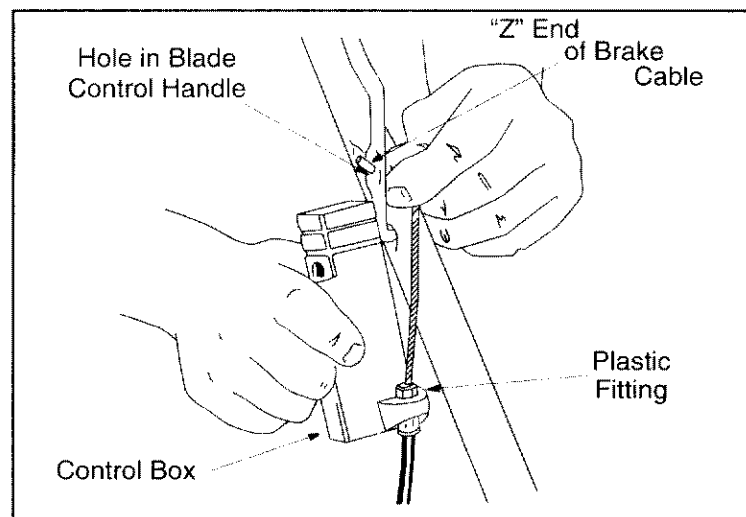

Figure 6

NOTE: If the control handle is disassembled from the upper handle for any reason, assemble the control handle by inserting the ends into the holes on each side of the upper handle. The hole in the control handle must be on the left side of the upper handle, and control handle must touch the upper handle when engaged (squeezed against the upper handle).

- Remove the truss machine screw and hex lock nut from the middle of the control box using a phillips screwdriver. Place your finger over the hex lock nut to hold it inside the control box so you can unscrew the truss machine screw.
- Make certain the blade control handle is on **top** of the upper handle.
- Route the control box (with cable attached) under the lower handle.
- Holding the control box near the left side of the upper handle (control box must be inside the handle), hook the “Z” end of the brake cable into the control handle from the **outside** to the **inside**. See Figure 6 and Figure 7.

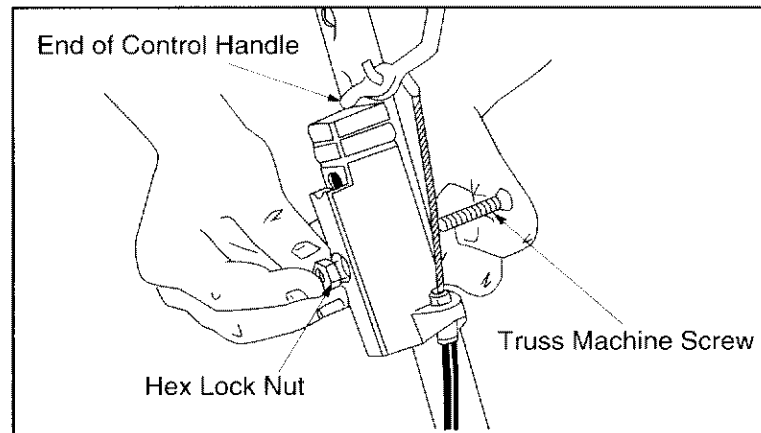

Figure 7

- Place the control box on the upper handle just below (touching) the end of the control handle as shown in Figure 7. Secure with hardware removed in step one by placing hex lock nut into the indent on the inside of the control box. Screw the truss machine screw into the hex lock nut.

SECURING THE CABLE (Hardware D)

Secure the cable to the left side of the handle as follows.



WARNING: When attaching the control cable, the cable must be routed to avoid contact with all sharp edges and hot surfaces to prevent damage to the cable.

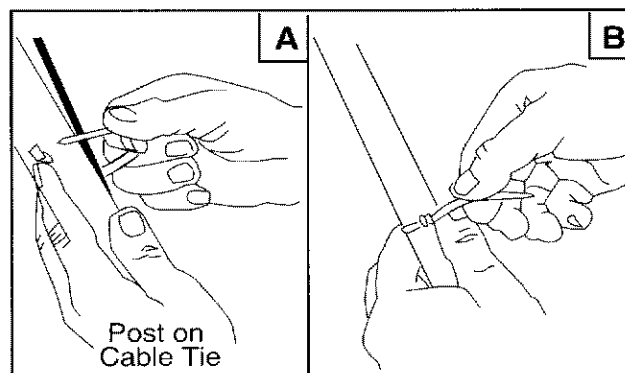

Figure 8

- Insert posts on cable ties into holes provided on the handle. There is one on the upper handle and two on the lower handle. See Figure 8A.
- Secure the cable with the cable ties. Trim excess ends of cable ties. See Figure 8B.

INSTALLATION OF WHEELS (Hardware E)

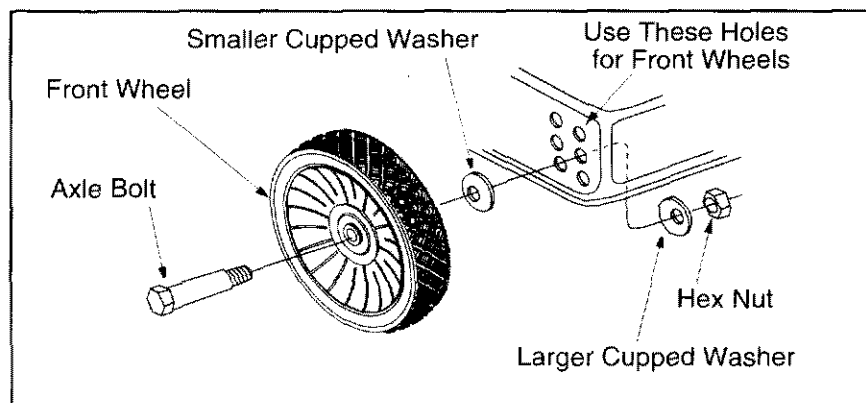

Figure 9

The three holes provide three cutting heights for your mower. Use the same hole location for all four wheels when assembling. If wheels are to be assembled in the lowest cutting position (highest hole in the deck), refer to the note below.

If your mower has two sets of holes (see Figure 9), the front wheels must be assembled in one of the three holes nearest the front of the deck. The rear wheels must be assembled in one of the three holes nearest the rear of the deck. To assemble the wheels: (See Figure 9).

- Block up the mower securely.
- Place axle bolt through wheel. (Hub side of wheel must face deck.)
- Place one smaller cupped washer on axle bolt, with the cupped side of washer toward the deck (away from wheel).

NOTE: If the lowest cutting position (highest hole in the deck) is used, it is necessary to place the larger washer on the outside of the deck and the smaller washer on the inside.

- Secure wheel to deck with one larger cupped washer on the inside of the deck (cupped side against the deck) and hex nut. Tighten securely.
- Assemble the other wheels in the same manner. Remove the blocks.

ATTACHING THE STARTER ROPE (Hardware C)

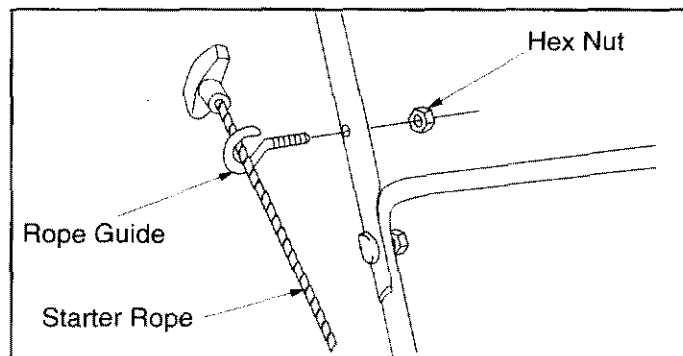

Figure 10

- The starter rope is inside the top of the engine. With the spark plug wire disconnected and grounded, depress the blade control handle and pull the rope out of the engine.
- Place the rope guide around the starter rope, so the opening in the rope guide is toward the front of the mower as shown. Insert the rope guide into the right side of the handle, and secure with hex lock nut. See Figure 10.

FINAL ASSEMBLY OF MOWER

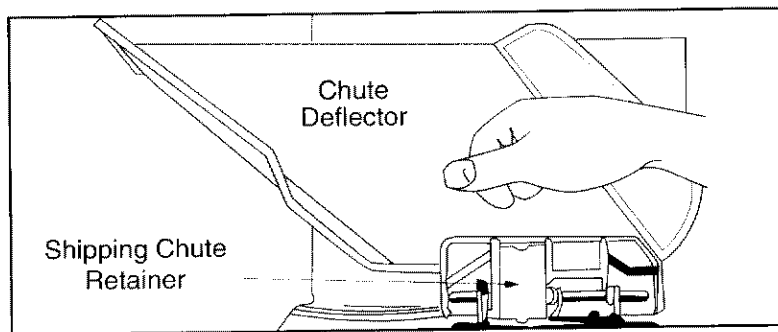

Figure 11

- The chute deflector on your mower is held in an upright position by a retainer for shipping purposes only. This shipping retainer must be removed and discarded before the mower is put into operation. See Figure 11. To remove the shipping chute retainer, move the spring-loaded chute toward the engine by pushing above the retainer. Remove the retainer and carefully lower the chute into operating position. Tighten bolts securely.

SECTION 8: CONTROLS

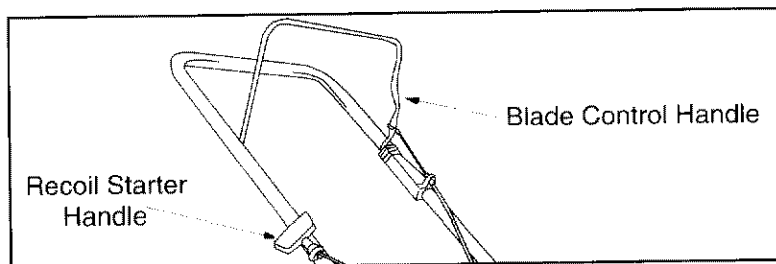

Figure 12

RECOIL STARTER

The recoil starter is attached to the handle. Stand behind the unit and pull the recoil starter to start the unit.

PRIMER

The primer is used to pump gas into the carburetor. Use it to start a cold engine, but do not use it to restart a warm engine after short shutdown. Refer to engine manual for illustration.

BLADE CONTROL HANDLE



WARNING: This control mechanism is a safety device. Never attempt to bypass its operations.

The blade control handle is located on the upper handle of the mower. The blade control handle must be depressed in order to operate the unit. Release the blade control handle to stop the engine and the blade.

OPTIONAL THROTTLE CONTROLS

The throttle control is used to regulate engine speed. Your unit may be equipped with one of three throttle controls. Follow the instructions which pertain to your unit.

- The throttle control is located on the left side of the upper handle.
- The throttle control is located on the engine.
- The engine has a constant speed throttle which is set at full throttle for maximum performance.



WARNING: The throttle control cannot be used to stop the engine. If your throttle control is located on the engine, do not adjust the throttle control with the engine running.

SECTION 9: OPERATION

Keep hands and feet away from the chute area on cutting deck. See Figure 2, Warning Label.



The operation of any lawn mower can result in foreign objects being thrown into the eyes, which can result in severe eye damage. Always wear safety glasses or eye shields. We recommend wide vision safety mask for over spectacles or standard safety glasses.

GAS AND OIL FILL-UP

Service the engine with gasoline and oil as instructed in the separate engine manual packed with your mower. Read instructions carefully.



WARNING: Never fill fuel tank indoors, with engine running or until the engine has been allowed to cool for at least two minutes after running.

STARTING ENGINE



WARNING: Be sure no one other than the operator is standing near the lawn mower while starting engine or operating mower.

Never run engine indoors or in enclosed, poorly ventilated areas. Engine exhaust contains carbon monoxide, an odorless and deadly gas.

Keep hands, feet, hair and loose clothing away from any moving parts on engine and lawn mower.

- Attach spark plug wire to spark plug. Make certain the metal cap on the end of the spark plug wire is fastened securely over the metal tip on the spark plug.
- Move throttle control to FAST position.
- Push primer three times. Wait about two seconds between each push. In cold weather around 55° F or below, prime five times. Do not prime to restart a warm engine after a short shutdown.
- Grasp starter handle and pull rope out slowly until engine reaches the start of compression cycle (rope will pull slightly harder at this point). Let the rope rewind slowly. Pull rope with a rapid, continuous, full arm stroke. Keeping a firm grip on the starter handle, let the rope return to the starter slowly.

STOPPING ENGINE

- Release blade control handle to stop the engine and the blade.
- Disconnect spark plug wire and move away from spark plug to prevent accidental starting.

USING YOUR ROTARY MOWER

Be sure that lawn is clear of stones, sticks, wire, or other objects which could damage lawn mower or engine. Such objects could be accidently thrown by the mower in any direction and cause serious personal injury to the operator and others.

For best results, do not cut wet grass because it tends to stick to the underside of the mower, preventing proper discharge of grass clippings, and could cause you to slip and fall. New grass or thick grass may require a narrower cut.

For a healthy lawn, never cut off more than one-third of the total length of the grass. Lawn should be cut in the fall as long as there is growth.



WARNING: If you strike a foreign object, stop the engine. Remove wire from spark plug, thoroughly inspect the mower for any damage, and repair the damage before restarting and operating the mower. Extensive vibration of the mower during operation is an indication of damage. The unit should be promptly inspected and repaired.

SECTION 10: ADJUSTMENTS



WARNING: Do not at any time make any adjustment to lawn mower without first stopping the engine and disconnecting spark plug wire.

CUTTING HEIGHT ADJUSTMENT

Adjustment may be made by removing and moving axle bolts to desired position. Cutting heights will be raised as axle bolts are moved to a lower hole and lowered as axle bolts are moved to a higher hole in the deck. All axle bolts must be mounted in the same relative position. Cupped washers must be assembled so that the cupped side of the washers are against the deck. Refer to Figure 9.

CARBURETOR ADJUSTMENTS



WARNING: If any adjustments are made to the engine while the engine is running (e.g. carburetor), keep clear of all moving parts. Be careful of heated surfaces and muffler.

Refer to the separate engine manual packed with your mower for carburetor adjustment information.

NOTE: A dirty air cleaner will cause an engine to run rough. Be certain air cleaner is clean and attached to the carburetor before adjusting the carburetor.

SECTION 11: LUBRICATION



WARNING: Always stop engine and disconnect spark plug wire before cleaning, lubricating or doing any kind of work on lawn mower.

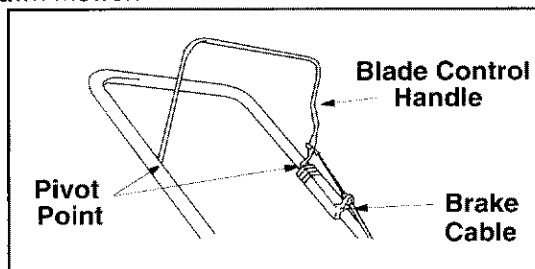

Figure 13

BLADE CONTROL

Lubricate the pivot points on the blade control handle and the brake cable at least once a season with light oil. See Figure 13. The blade control must operate freely in both directions.

CHUTE DEFLECTOR

The torsion spring and pivot point should be lubricated periodically with light oil to prevent any rust or binding. Deflector must work freely.

WHEELS

The wheels require no lubrication. However, if the wheels are removed for any reason, lubricate the surface of the axle bolt and the inner surface of the wheel with light oil. Engine oil may also be used.

ENGINE

Follow engine manual for lubrication instructions.

SECTION 12: MAINTENANCE



WARNING: Be sure to disconnect and ground the spark plug wire before performing any repairs or maintenance.

NOTE: When tipping the unit, empty the fuel tank and keep engine air filter side up.

TROUBLE SHOOTING

Refer to page 17 of this manual for trouble shooting information.

CUTTING BLADE

When removing the cutting blade for sharpening or replacement, protect hands by using heavy gloves or a thick rag to grasp the cutting blade. Remove the bolt and blade support which hold the blade and adapter to the engine crankshaft. Remove the blade and adapter from the crankshaft.

When sharpening the blade, follow the original angle of grind as a guide. It is **extremely important** that each cutting edge receives an equal amount of grinding to prevent an unbalanced blade. An unbalanced blade will cause excessive vibration when rotating at high speeds, and may cause damage to the mower or cause personal injury.

The blade can be tested by balancing it on a round shaft screwdriver. Remove metal from the heavy side until it balances evenly. It is recommended that the blade always be removed from the adapter for the best test of balance.

Before reassembling the blade and the blade adapter to the unit, lubricate the engine crankshaft and the inner surface of the blade adapter with light oil (or engine oil).

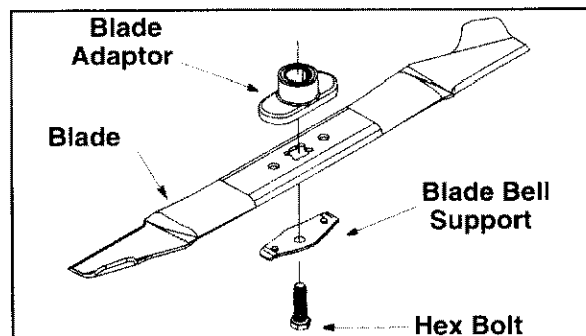

Figure 14

Install the blade adaptor on the crankshaft with the “star” away from the engine. Refer to Figure 14. Place the blade with the side marked bottom (or with part number) facing away from the adapter. Align the blade bell support over the blade with the tabs in the holes of the blade and insert the hex bolt. Tighten the hex bolt to the torque listed in the “Blade Mounting Torque” section below.

Blade Mounting Torque

Center Bolt: 450 in. lbs. min., 600 in. lbs. max.

To ensure safe operation of your unit, **all** nuts and bolts must be checked periodically for correct tightness.

DECK

The underside of the mower deck should be cleaned after each use to prevent a buildup of debris. If this debris is allowed to accumulate, it will invite rust and corrosion, and may cause an uneven discharge of grass clippings at the next cutting.

The deck may be cleaned by tilting the mower and scraping clean with a suitable tool (make certain the spark plug wire is disconnected).

ENGINE

Refer to the separate engine manual for engine maintenance instructions.

Maintain **engine oil** as instructed in the separate engine manual packed with your unit. Follow instructions carefully.

Service **air cleaner** every 25 hours under normal conditions. Clean every few hours under extremely dusty conditions. Poor engine performance and flooding usually indicates that the air cleaner should be serviced. To service the air cleaner, refer to the separate engine manual packed with your unit.

The **spark plug** should be cleaned and the gap reset once a season. Spark plug replacement is recommended at the start of each mowing season; check engine manual for correct plug type and gap specifications.

Clean the engine regularly with a cloth or brush. Keep the top of the engine clean to permit proper air circulation which is essential to cooling the engine. Be certain to remove all debris from muffler area.

SECTION 13: OFF-SEASON STORAGE

The following steps should be taken to prepare lawn mower for storage.

1. Clean and lubricate mower thoroughly as described in the lubrication instructions.
2. Refer to engine manual for correct engine storage instructions.
3. Coat mower's cutting blade with chassis grease to prevent rusting.
4. Store mower in a dry, clean area. Do not store next to corrosive materials, such as fertilizer.

NOTE: When storing any type of power equipment in a poorly ventilated or metal storage shed, care should be taken to rust-proof the equipment. Using a light oil or silicone, coat the equipment, especially cables and all moving parts.

SECTION 14: TROUBLE SHOOTING GUIDE

Trouble	Possible Cause(s)	Corrective Actions
Engine fails to start	Blade control handle disengaged. Spark plug wire disconnected. Dirty air cleaner. Primer button not depressed. Throttle control lever not in correct starting position (if so equipped). Fuel tank empty or stale fuel. Blocked fuel line (if so equipped). Faulty spark plug. Engine flooded.	Engage blade control handle. Connect wire to spark plug. Refer to the engine manual packed with your unit. Refer to the engine manual packed with your unit. Move throttle lever to FAST or START position. Fill tank with clean fresh gasoline. Fuel will not last over thirty days unless a fuel stabilizer is used. Clean fuel line. Clean, adjust gap or replace. Crank engine w/ throttle (if equipped) in SLOW position.
Engine runs erratic	Unit running in START position. Spark plug wire loose. Blocked fuel line (if so equipped) or stale fuel. Vent in gas cap plugged. Water or dirt in fuel system. Dirty air cleaner. Carburetor out of adjustment.	Move throttle lever (if equipped) to FAST position. Connect and tighten spark plug wire. Check spark plug for fouling. Clean fuel line; fill tank with clean, fresh gasoline. Fuel will not last over thirty days unless a fuel stabilizer is added. Clean vent or threads or replace. Drain fuel tank. Refill with fresh fuel. Refer to the engine manual packed with your unit. Refer to the engine manual packed with your unit.
Engine overheats	Engine oil level low. Dirty air cleaner. Air flow restricted. Carburetor not adjusted properly.	Fill crankcase with proper oil. Refer to the engine manual packed with your unit. Stop engine and disconnect spark plug wire. Remove blower housing and clean. Refer to the engine manual packed with your unit or see an authorized service dealer.*
Occasional skip (hesitates) at high speed	Spark plug gap too close. Carburetor idle mixture adjustment improperly set.	Adjust gap to .030". Refer to the engine manual packed with your unit.
Idles poorly	Spark plug fouled, faulty or gap too wide. Carburetor improperly adjusted. Dirty air cleaner.	Reset gap to .030" or replace spark plug. Refer to the engine manual packed with your unit. Refer to the engine manual packed with your unit.
Excessive vibration	Cutting blade loose or unbalanced. Bent cutting blade.	Tighten blade and adapter. Balance blade. See an authorized service dealer.
Uneven cut	Wheels not positioned correctly. Dull blade.	Place all four wheels in same height position. Sharpen or replace blade.

Note: For repairs beyond the minor adjustments above, contact your local authorized service dealer.

Model Series 060

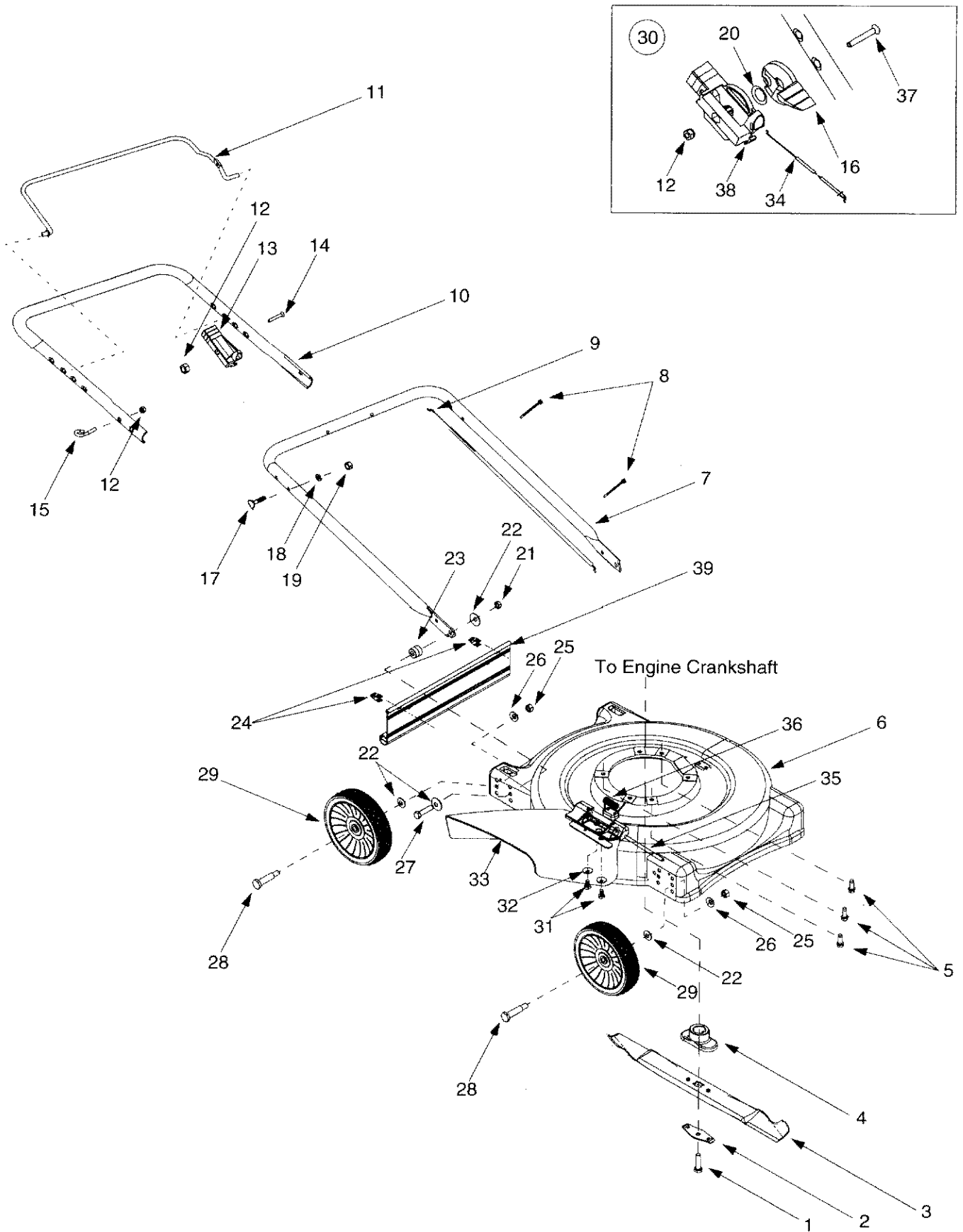

Model Series 060

REF. NO.	PART NO.	DESCRIPTION	REF. NO.	PART NO.	DESCRIPTION
1	710-1044	Hex Bolt 3/8-24 x 1.5" Lg.	21	712-0355	Hex L-Nut 3/8-24 Thd.
2	736-0524A	Support, Bell-Blade	22	736-0105	Bell Washer .380 ID x .88"
3	742-0642	22" Blade, Std.	23	750-0910	Spacer .391" I.D. x .375" Lg.
4	748-0376C	Adaptor, Blade	24	17098	Hinge Clip
5	710-0654A	Screw: TTSeams, 3/8 - 16 x 1"	25	712-0798	Hex Nut 3/8 - 16
6	682-0086	Deck Assy, 22" Side Discharge	26	736-0331	Bell Washer .39 I.D. x 1.13
7	749-0928	Lower Handle	27	710-0459A	Hex Bolt 3/8 -24 x 1.5
8	726-0240	Cable Tie	28	738-0533	Axle Bolt
9	746-0550	Control Cable-39"	29	734-1780	Wheel Assy
10	749-0538C	Upper Handle	30	811-00185	Throttle Box Complete (Optional)
11	747-0824	Control Handle	31	710-0599	Hex Self-Tap Scr. 1/4-20 x .5"
12	712-0324	Hex L-Nut 1/4-20 Thd.	32	736-0270	Bell-Wash. 1/4" I.D.
13	746-0883	Control Cable Box	33	746-1034	Chute Deflector Ass'y 731-1034
14	710-1270	Oval C-Sunk Scr.	34	746-0842	Throttle Cable, 51"(Optional)
15	710-1205	Rope Guide	35	747-0710	Hinge Pin
16	746-0876	Throttle Lever (Optional)	36	732-0593	Torsion Spring
17	710-1250	Curved Carr. Bolt 5/16-18 x 1"	37	710-0605	Oval C-Sunk Scr. (Optional)
18	736-0119	L-Wash. 5/16" I.D.	38	646-0875	Throttle Body (Optional)
19	712-0267	Hex Nut 5/16-18 Thd.	39	731-1029	Rear Trail Sheild
20	736-0501	Spring Washer (Optional)			

MANUFACTURER'S LIMITED WARRANTY

For TWO YEARS from the date of retail purchase within the United States of America, its possessions and territories, the manufacturer will, at its option, repair or replace, for the original purchaser, free of charge, any part or parts found to be defective in material or workmanship. This warranty covers units which have been operated and maintained in accordance with the operating instructions furnished with the unit, and which have not been subject to misuse, abuse, commercial use, neglect, accident, improper maintenance or alteration.

Normal wear parts or components thereof are subject to separate terms as noted below in the "No Fault Ninety Day Consumer Warranty" clause.

All normal wear part failures will be covered on this product for a period of 90 days regardless of cause. After 90 days, but within the two year period, normal wear parts failures will be covered ONLY IF caused by defects in material or workmanship of OTHER component parts. Normal wear parts are defined as batteries*, belts, blades, blade adapters, grass bags, rider deck wheels, seats, snow thrower skid shoes, shave plates and tires.

How to obtain service: Warranty service is available, with proof of purchase, through your local authorized service dealer. To locate the dealer in your area, please check the yellow pages or contact the Customer Service Department of the manufacturer, P. O. Box 368022, Cleveland, Ohio 44136-9722. Phone 1-330-273-4683. The return of a complete unit will not be accepted by the factory unless prior written permission has been extended by the service department of the manufacturer.

Transportation charges: Transportation charges for the movement of any power equipment unit or attachment are the responsibility of the purchaser.

Units exported out of the United States: The manufacturer does not extend any warranty for products sold or exported outside of the United

States of America, its possessions and territories, except those sold through the manufacturer's authorized channels of export distribution.

Other Warranties:

1. The engine or component parts thereof carry separate warranties from their manufacturers. Please refer to the applicable manufacturer's warranty on these items.
2. *Batteries are covered by a 90-day replacement warranty.
3. Log splitter pumps, valves and cylinders or component parts thereof are covered by a one year warranty.
4. All other warranties, express or implied, including any implied warranty of merchantability or fitness for a particular purpose, are hereby expressly disclaimed in their entirety.
5. The provisions as set forth in this warranty provide the sole and exclusive remedy of the manufacturer's obligations arising from the sales of its products. The manufacturer will not be liable for incidental or consequential loss or damage.

How state law relates to this warranty: This limited warranty gives you specific legal rights, and you may also have other rights which vary from state to state. Certain disclaimers are not allowed in some states and therefore they may not apply to you under all circumstances.

NOTE: This warranty does not cover routine maintenance items such as lubricants, filters, blade sharpening and tune-ups, or adjustments such as brake adjustments, clutch adjustments or deck adjustments. Nor does this warranty cover normal deterioration of the exterior finish due to use or exposure.