

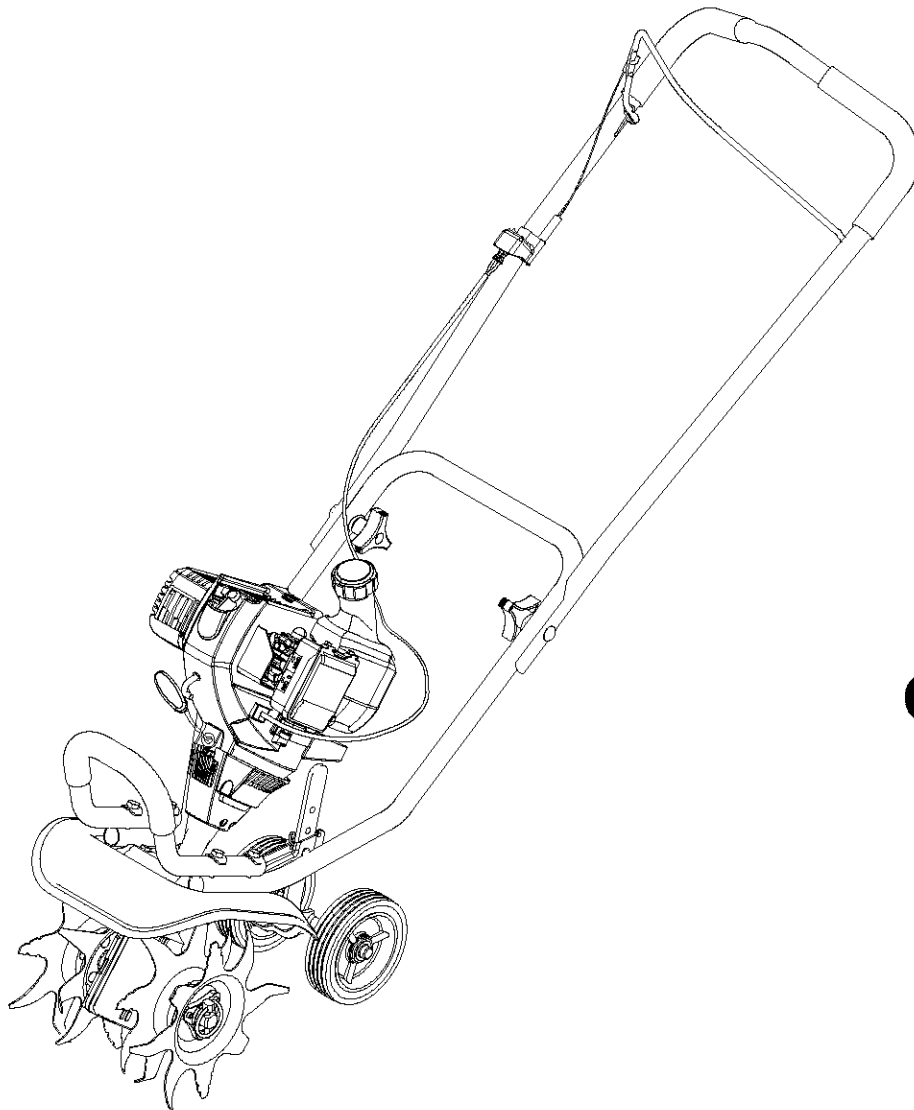

Operator's Manual



**4-Cycle
Gasoline
Cultivator**

IMPORTANT: READ SAFETY RULES AND INSTRUCTIONS CAREFULLY

P/N 769-00874 (10/03)
PRINTED IN USA

INTRODUCTION

THANK YOU

Thank you for buying this quality product. This modern outdoor power tool will provide many hours of useful service. You will find it to be a great labor-saving device. This operator's manual provides you with easy-to-understand operating instructions. Read the whole manual and follow all the instructions to keep your new outdoor power tool in top operating condition.

PRODUCT REFERENCES, ILLUSTRATIONS AND SPECIFICATIONS

All information, illustrations, and specifications in this manual are based on the latest product information available at the time of printing. We reserve the right to make changes at any time without notice.

Copyright© 2003 MTD SOUTHWEST INC, All Rights Reserved.

SERVICE INFORMATION

Service on this unit both within and after the warranty period should be performed only by an authorized and approved service dealer.

For service call **1-800-520-5520** to obtain a list of authorized service dealers near you. For more details about your unit, visit our website at www.troybilt.com.

DO NOT RETURN THE UNIT TO THE RETAILER. PROOF OF PURCHASE WILL BE REQUIRED FOR WARRANTY SERVICE.

Before beginning, locate the unit's model plate. It lists the model and serial numbers of your unit. Refer to the sample plate below and copy the information for future reference.

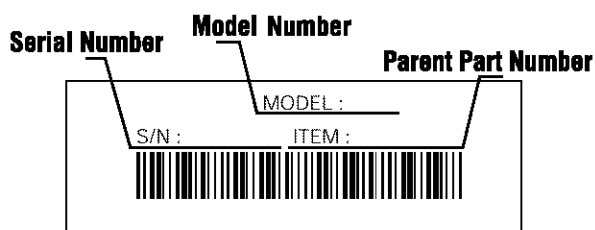

Copy the model and parent part number here: _____

Copy the serial number here: _____

Make sure you carefully read and understand this manual before starting or operating this equipment.

THIS PRODUCT IS COVERED BY ONE OR MORE U.S. PATENTS. OTHER PATENTS PENDING.

TABLE OF CONTENTS

Service Information	2
Rules for Safe Operation	3
Know Your Unit	6
Assembly Instructions	7
Oil and Fuel Information	8
Starting/Stopping Instructions	10
Operating Instructions	11
Maintenance and Repair Instructions	12
Cleaning and Storage	18
Troubleshooting Chart	19
Specifications	20
Warranty Information	22
Parts List	Inside Back Cover

SPARK ARRESTOR NOTE

NOTE: For users on U.S. Forest Land and in the states of California, Maine, Oregon and Washington. All U.S. Forest Land and the state of California (Public Resources Codes 4442 and 4443), Oregon and Washington require, by law that certain internal combustion engines operated on forest brush and/or grass-covered areas be equipped with a spark arrestor, maintained in effective working order, or the engine be constructed, equipped and maintained for the prevention of fire. Check with your state or local authorities for regulations pertaining to these requirements. Failure to follow these requirements could subject you to liability or a fine. **This unit is factory equipped with a spark arrestor.** If it requires replacement, ask your LOCAL SERVICE DEALER to install the **Accessory Part #180890 Spark Arrestor Kit.**

CALIFORNIA PROPOSITION 65 WARNING

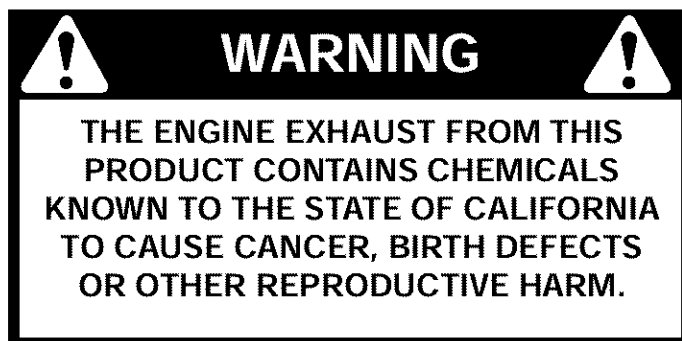

RULES FOR SAFE OPERATION

The purpose of safety symbols is to attract your attention to possible dangers. The safety symbols, and their explanations, deserve your careful attention and understanding. The safety warnings do not by themselves eliminate any danger. The instructions or warnings they give are not substitutes for proper accident prevention measures.

SYMBOL	MEANING
--------	---------



SAFETY ALERT: Indicates danger, warning or caution. Attention is required in order to avoid serious personal injury. May be used in conjunction with other symbols or pictographs.

NOTE: Advises you of information or instructions vital to the operation or maintenance of the equipment.

Read the Operator's Manual(s) and follow all warnings and safety instructions.

Failure to do so can result in serious injury to the operator and/or bystanders.

FOR QUESTIONS, CALL 1-800-520-5520.

SYMBOL	MEANING
--------	---------



DANGER: Failure to obey a safety warning will result in serious injury to yourself or to others. Always follow the safety precautions to reduce the risk of fire, electric shock and personal injury.



WARNING: Failure to obey a safety warning can result in injury to yourself and others. Always follow the safety precautions to reduce the risk of fire, electric shock and personal injury.



CAUTION: Failure to obey a safety warning may result in property damage or personal injury to yourself or to others. Always follow the safety precautions to reduce the risk of fire, electric shock and personal injury.

• IMPORTANT SAFETY INSTRUCTIONS •

READ ALL INSTRUCTIONS BEFORE OPERATING



WARNING: When using the unit, you must follow the safety rules. Please read these instructions before operating the unit in order to ensure the safety of the operator and any bystanders. Please keep these instructions for later use.

- Read the instructions carefully. Be familiar with the controls and proper use of the unit.
- Do not operate this unit when tired, ill, or under the influence of alcohol, drugs, or medication.
- Children and teens under the age of 15 must not use the unit, except for teens guided by an adult.
- All guards and safety attachments must be installed properly before operating the unit.
- Inspect the unit before use. Replace damaged parts. Check for fuel leaks. Make sure all fasteners are in place and secure. Replace parts that are cracked, chipped, or damaged in any way. Do not operate the unit with loose or damaged parts.

- Carefully inspect the area before starting the unit. Remove all debris and hard or sharp objects such as glass, wire, etc.
- Be aware of the risk of injury to the head, hands and feet.
- Clear the area of children, bystanders, and pets. At a minimum, keep all children, bystanders, and pets outside a 50 feet (15 m.) radius; there still may be a risk to bystanders from thrown objects. Bystanders should be encouraged to wear eye protection. If you are approached, stop the unit immediately.
- Squeeze the throttle control and check that it returns automatically to the idle position. Make all adjustments or repairs before using unit.

SAFETY WARNINGS FOR GAS UNITS



WARNING: Gasoline is highly flammable, and its vapors can explode if ignited. Take the following precautions:

- Store fuel only in containers specifically designed and approved for the storage of such materials.
- Avoid creating a source of ignition for spilled fuel. Do not start the engine until fuel vapors dissipate.

RULES FOR SAFE OPERATION

- Always stop the engine and allow it to cool before filling the fuel tank. Never remove the cap of the fuel tank, or add fuel, when the engine is hot. Never operate the unit without the fuel cap securely in place. Loosen the fuel tank cap slowly to relieve any pressure in the tank.
- Add fuel in a clean, well-ventilated outdoor area where there are no sparks or flames. Slowly remove the fuel cap only after stopping engine. Do not smoke while fueling or mixing fuel. Wipe up any spilled fuel from the unit immediately. Always wipe unit dry before using.
- Move the unit at least 30 feet (9.1 m) from the fueling source and site before starting the engine. Do not smoke or allow sparks and open flames near the area while adding fuel or operating the unit.

WHILE OPERATING

- Never start or run the unit inside a closed room or building. Breathing exhaust fumes can kill. Operate this unit only in a well ventilated outdoor area.
- Wear safety glasses or goggles that are marked as meeting ANSI Z87.1-1989 standards. Also wear ear/hearing protection when operating this unit. Wear a face or dust mask if the operation is dusty. Long sleeve shirts are recommended.
- Wear heavy, long pants, boots and gloves. Do not wear loose clothing, jewelry, short pants, sandals or go barefoot. Secure hair above shoulder level.
- This unit has a clutch. The tines remains stationary when the engine is idling. If it does not, have the unit adjusted by an authorized service technician.
- Be sure the tines are not in contact with anything before starting the unit.
- Use the unit only in daylight or good artificial light.
- Avoid accidental starting. The operator and unit must be in a stable position while starting. See *Starting/Stopping Instructions*.
- Use the right tool. Only use this tool for the purpose intended.
- Use extreme caution when reversing or pulling the unit towards you.
- Do not overreach. Always keep proper footing and balance. Take extra care when working on steep slopes or inclines.
- Always hold the unit with both hands when operating. Keep a firm grip on the grips.
- Keep hands, face, and feet at a distance from all moving parts. Do not touch or try to stop the tines when they are rotating.

- Do not touch the engine or muffler. These parts get extremely hot from operation. They remain hot for a short time after you turn off the unit.
- Do not operate the engine faster than the speed needed to cultivate. Do not run the engine at high speed when you are not cultivating.
- Always stop the engine when cultivating is delayed or when walking from one cultivating location to another.
- If you strike or become entangled with a foreign object, stop the engine immediately and check for damage. Do not operate before repairing damage. Do not operate the unit with loose or damaged parts.
- Stop and switch the engine to off for maintenance, repair, or to install or remove the tines.

Use only original equipment manufacturer replacement parts and accessories for this unit. These are available from your authorized service dealer. Use of any unauthorized parts or accessories could lead to serious injury to the user, or damage to the unit, and void your warranty.

- Keep unit clean of vegetation and other materials. They may become lodged between the tines and guard.
- To reduce fire hazard, replace faulty muffler and spark arrestor, keep the engine and muffler free from grass, leaves, excessive grease or carbon build up.

OTHER SAFETY WARNINGS

- Never store the unit, with fuel in the tank, inside a building where fumes may reach an open flame or spark.
- Allow the engine to cool before storing or transporting. Be sure to secure the unit while transporting.
- Store the unit in a dry area, locked up or up high to prevent unauthorized use or damage, out of the reach of children.
- Never douse or squirt the unit with water or any other liquid. Keep handles dry, clean and free from debris. Clean after each use. See the *Cleaning and Storage* instructions.
- Keep these instructions. Refer to them often and use them to instruct other users. If you loan someone this unit, also loan them these instructions.

SAVE THESE INSTRUCTIONS

RULES FOR SAFE OPERATION

SAFETY AND INTERNATIONAL SYMBOLS

This operator's manual describes safety and international symbols and pictographs that may appear on this product. Read the operator's manual for complete safety, assembly, operating and maintenance and repair information.

SYMBOL

MEANING



• SAFETY ALERT SYMBOL

Indicates danger, warning, or caution. May be used in conjunction with other symbols or pictographs.



• WARNING - READ OPERATOR'S MANUAL

Read the Operator's Manual(s) and follow all warnings and safety instructions. Failure to do so can result in serious injury to the operator and/or bystanders.



• WEAR EYE AND HEARING PROTECTION

WARNING: Thrown objects and loud noise can cause severe eye injury and hearing loss. Wear eye protection meeting ANSI Z87.1-1989 standards and ear protection when operating this unit. Use a full face shield when needed.



• KEEP BYSTANDERS AWAY

WARNING: Keep all bystanders, especially children and pets, at least 50 feet (15 m.) from the operating area.



• UNLEADED FUEL

Always use clean, fresh unleaded fuel.



• OIL

Refer to operator's manual for the proper type of oil.

SYMBOL

MEANING



• THROWN OBJECTS AND ROTATING CUTTER CAN CAUSE SEVERE INJURY

WARNING: Do not operate without the proper guards in place. Keep away from the rotating tines.



• ON/OFF STOP CONTROL

ON / START / RUN



• ON/OFF STOP CONTROL

OFF or STOP



• HOT SURFACE WARNING

Do not touch a hot muffler or cylinder. You may get burned. These parts get extremely hot from operation. When turned off they remain hot for a short time.



• GARDEN CULTIVATORS - ROTATING TINES CAN CAUSE SEVERE INJURY

WARNING: Stop the engine and allow the tines to stop before installing or removing tines, or before cleaning or performing any maintenance. Keep hands and feet away from rotating tines.

KNOW YOUR UNIT

APPLICATION

Use this unit for cultivating sod and light to medium soil.
Also for cultivating in garden areas, around trees, etc.

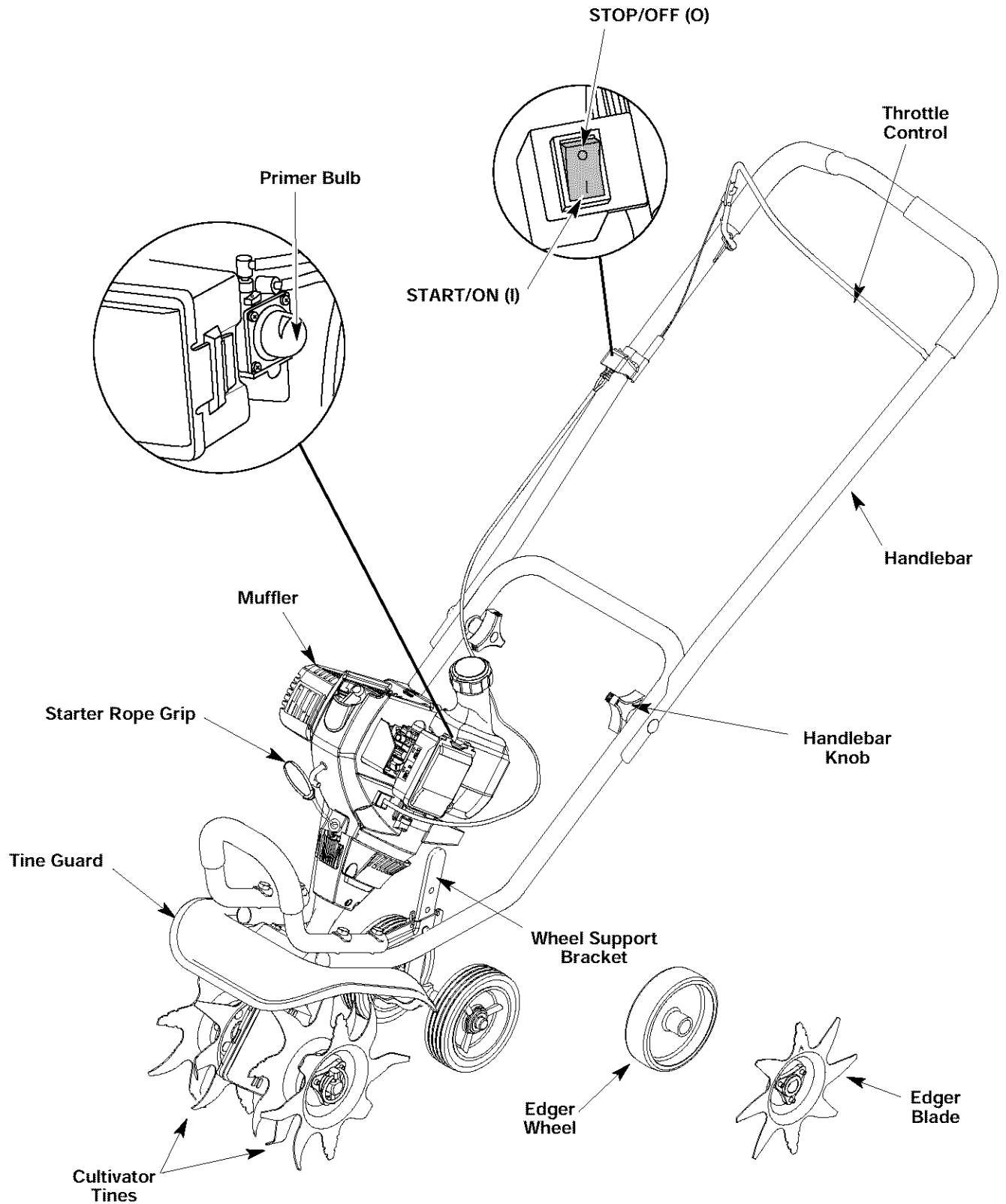

ASSEMBLY INSTRUCTIONS

NOTE: This unit is shipped without gasoline or oil. In order to avoid damage to the unit, refer to *Oil and Fuel Information* to put oil and gas in the crankcase before attempting to start it.

NOTE: Before setting up your cultivator / edger, disconnect the spark plug wire from the spark plug and ground to a stud on the engine.

POSITIONING THE HANDLEBARS

1. Loosen the two knobs on the inside of the handlebars (Fig. 1).
2. With the unit upright, swing the handlebars up into the operating position (Fig. 1).

NOTE: Take care not to pinch the throttle cable or switch wires when positioning the handlebar.

3. Tighten the knobs to secure the handlebars in place.

NOTE: Do not over-tighten the knobs.

ADJUSTING THE HANDLEBAR HEIGHT

1. Remove the knobs and mounting bolts and reinstall them through either the top or bottom holes in the handlebar assembly (Fig. 2) in order to adjust the height of the handlebars.
2. Be sure to tighten the knobs to secure the handlebars in place.

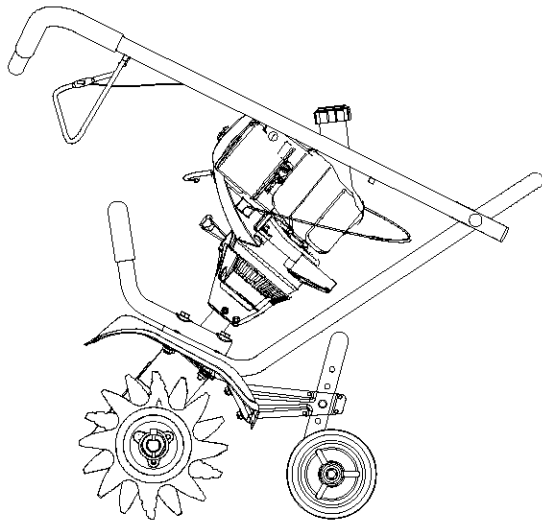

Fig. 1

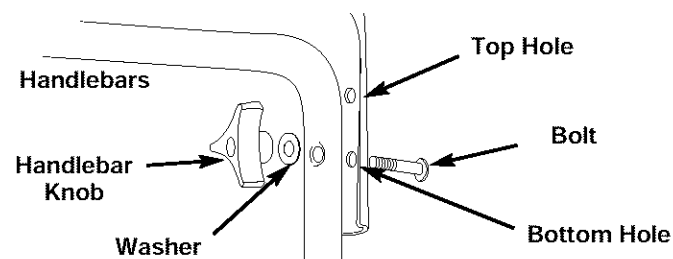

Fig. 2

ADJUSTING TINE DEPTH

To adjust the wheel support bracket proceed as follows:

1. Stop the engine and disconnect the spark plug to avoid accidental starting.
2. Remove cotter pin from the clevis pin and slide pin out of tailpiece bracket (Fig. 3).
3. Slide the wheel support bracket up or down in the tailpiece, aligning the holes to the desired height.
4. Place the clevis pin through the hole and secure with a cotter pin.

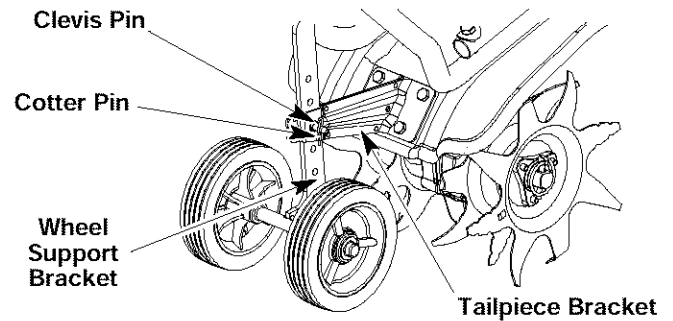

Fig. 3

ATTACHING THE EDGER WHEEL AND BLADE

To convert the cultivator to an edger proceed as follows:

1. Push the On/Off switch to Off (O) position to stop engine and tines and disconnect spark plug to avoid accidental starting.

NOTE: It may be necessary to lay the cultivator / edger back in a horizontal position on a flat level surface with the upper handle touching the ground.

2. Remove the click pin from each end of the tine shaft and slide the tines off the shaft.
3. Slide the edger wheel, with the hub facing inward, onto the right side of the tine shaft and secure with the click pin in the inside hole (Fig. 4).
4. Slide the edger blade with the hub facing out onto the left side of tine shaft and secure with the click pin in the inside hole (Fig. 4).
5. Guide the edger blade along a flower bed, sidewalk, or driveway with the edger wheel along the outside edge. Use the edger guide line to line up edger blade.

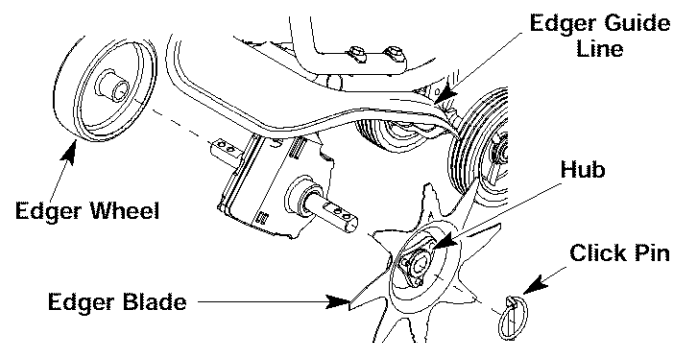



Fig. 4

OIL AND FUEL INFORMATION

	<p>WARNING: OVERFILLING OIL CRANKCASE MAY CAUSE SERIOUS PERSONAL INJURY. Check and maintain the proper oil level in the crank case; it is important and cannot be overemphasized. Check the oil before each use and change it as needed. See <i>Changing the Oil</i>.</p>
--	--

RECOMMENDED OIL TYPE

 Using the proper type and weight of oil in the crankcase is extremely important. Check the oil before each use and change the oil regularly. Using incorrect or dirty oil can cause premature engine wear and failure.

Use a high-quality SAE 30 weight oil of API (American Petroleum Institute) service class SF, SG, SH.

ADDING OIL TO CRANKCASE: INITIAL USE

NOTE: This unit is shipped without oil. In order to avoid damage to the unit, put oil in the crankcase before attempting to start unit.

Your unit is supplied with one 3.4 fluid oz. (100 ml.) bottle of SAE 30 SF, SG, SH oil (Fig. 5).

NOTE: Save the bottle to measure the correct amount for future oil changes. See *Changing the Oil*.

NOTE: Your new 4-Cycle cultivator is shipped for operation in conditions above 40°F (4°C). For cold weather operation, where temperatures plummet below 40°F (4°C), use a high-quality SAE 10W30 weight oil of API (American Petroleum Institute) service class SF, SG, SH.

1. Unscrew the oil bottle top and remove the paper seal covering the opening. Replace the top and cut the tip off the funnel spout (Fig. 5).
2. Place the unit on a flat level surface with the cultivator in a horizontal position (Fig. 6).
3. Remove the oil plug / dipstick from the crankcase (Fig. 7).
4. Pour the entire bottle of oil into the oil fill hole (Fig. 8).

NOTE: Never add oil to the fuel or fuel tank.

5. Remove the tag from oil fill plug / dipstick.
6. Wipe up any oil that may have spilled and reinstall the oil fill plug / dipstick.

The importance of checking and maintaining the proper oil level in the crankcase cannot be overemphasized. Check oil before each use and change as specified in the *Maintenance Schedule*.

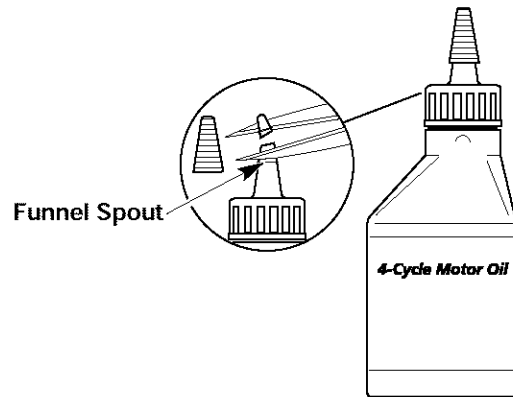

Fig. 5

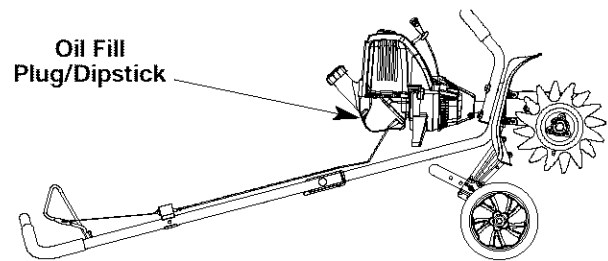

Fig. 6

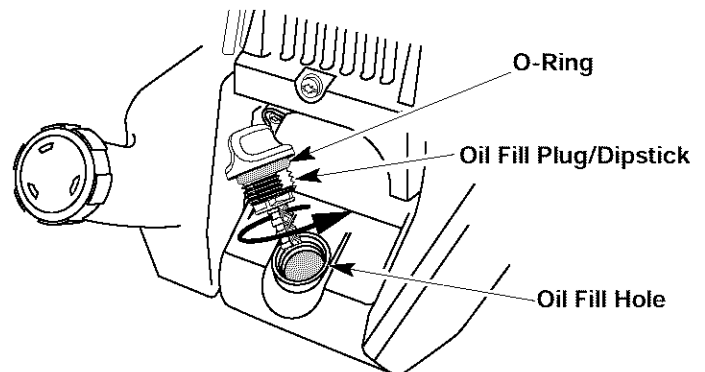

Fig. 7

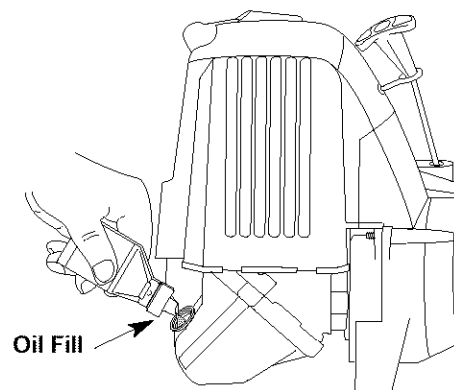

Fig. 8

OIL AND FUEL INFORMATION

RECOMMENDED FUEL TYPE



Old fuel is the primary reason for improper unit performance. Be sure to use fresh, clean, unleaded gasoline.

NOTE: This is a four cycle engine. In order to avoid damage to the unit, **do not mix oil with gasoline.**

Definition of Blended Fuels

Today's fuels are often a blend of gasoline and oxygenates such as ethanol, methanol or MTBE (ether). Alcohol-blended fuel absorbs water. As little as 1% water in the fuel can make fuel form acids when stored. When using alcohol-blended fuel, use fresh fuel that is less than 60 days old.

Using Blended Fuels

If you choose to use a blended fuel, or if its use is unavoidable, follow recommended precautions:

- Always use fresh unleaded gasoline
- Use the fuel additive STA-BIL® or an equivalent
- Drain tank and run the engine dry before storing unit

Using Fuel Additives

The use of fuel additives, such as STA-BIL® Gas Stabilizer or an equivalent, will inhibit corrosion and minimize the formation of gum deposits. Using a fuel additive can keep fuel from forming harmful deposits in the carburetor for up to six (6) months. Add 0.8 oz. (23 ml.) of fuel additive per gallon of fuel according to the instructions on the container. NEVER add fuel additives directly to the unit's gas tank.

FUELING THE UNIT

1. Remove fuel cap. Remove the tag from the fuel tank neck.

NOTE: Fill or add fuel to the tank only when the cultivator is in a horizontal position (Fig. 9).

2. Place spout of gas container into the fill hole on the fuel tank and fill tank.

NOTE: Do not overfill tank.

3. Wipe up any gasoline that may have spilled.
4. Reinstall the fuel cap.
5. Move the unit at least 30 ft. (9.1 m) from the fueling source and site before starting the engine.

NOTE: Dispose of the old gasoline in accordance to Federal, State and Local regulations.

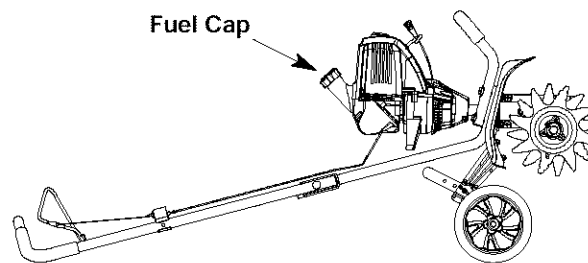

Fig. 9



WARNING: Gasoline is extremely flammable. Ignited Vapors may explode. Always stop the engine and allow it to cool before filling the fuel tank. Do not smoke while filling the tank. Keep sparks and open flames at a distance from the area.



WARNING: Remove fuel cap slowly to avoid injury from fuel spray. Never operate the unit without the fuel cap securely in place.



WARNING: Add fuel in a clean, well ventilated outdoor area. Wipe up any spilled fuel immediately. Avoid creating a source of ignition for spilt fuel. Do not start the engine until fuel vapors dissipate.

STARTING/STOPPING INSTRUCTIONS



WARNING: Operate this unit only in a well-ventilated outdoor area. Carbon monoxide exhaust fumes can be lethal in a confined area.



WARNING: Avoid accidental starting. Make sure you are in the starting position when pulling the starter rope (Fig. 12). To avoid serious injury, the operator and unit must be in a stable position while starting.

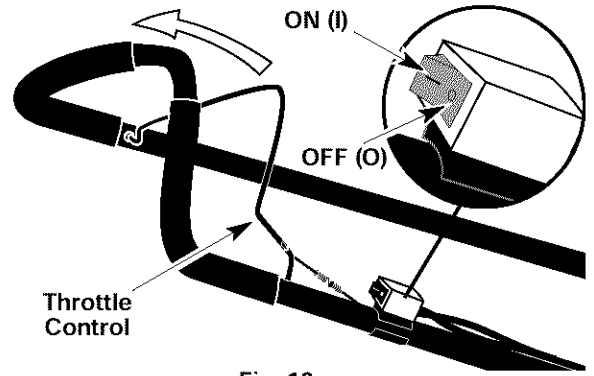

Fig. 10

STARTING INSTRUCTIONS

1. Check the oil level in the crankcase. Refer to *Checking the Oil Level*.
2. Fill the fuel tank with fresh, clean unleaded gasoline. Refer to *Fueling the Unit*.

NOTE: There is no need to turn the unit on. The On/Off Stop Control is in the ON (I) position at all times (Fig. 10).

IF COLD... For cold weather conditions (below 40°F), flip the Cold Weather Start Lever (Fig. 13) to the start/close position and continue to step 4. **DO NOT** flip this lever down if the temperature is above 40°F.

3. Fully press and release the primer bulb 10 times, slowly. Some amount of **fuel should be visible in the primer bulb** and fuel lines (Fig. 11). If you can't see fuel in the bulb, press and release the bulb as many times as it takes before you can see fuel in it.

4. Hold the handlebar with one hand and grab the starter rope with your other hand. Use your foot to hold down the cultivator (Fig. 12).

NOTE: Tilt the unit back slightly to bring the tines off the ground when starting.

5. With the unit in the starting position, **do not squeeze the throttle control** (Fig. 12). Pull the starter rope out a short distance, until you feel some resistance. This is usually around 2-4 inches. Then pull the rope smoothly and briskly. Repeat this 5 times.

IF COLD... For cold weather conditions (below 40°F), flip the Cold Weather Start Lever back to the run/open position.

6. When the engine starts, squeeze the throttle control to warm up the engine for 15 to 30 seconds. In cold weather, let the engine warm up for 30 to 60 seconds.

IF... The engine does not start, go back to step 3.

IF... The engine stops while you are squeezing the throttle, go back to step 4.

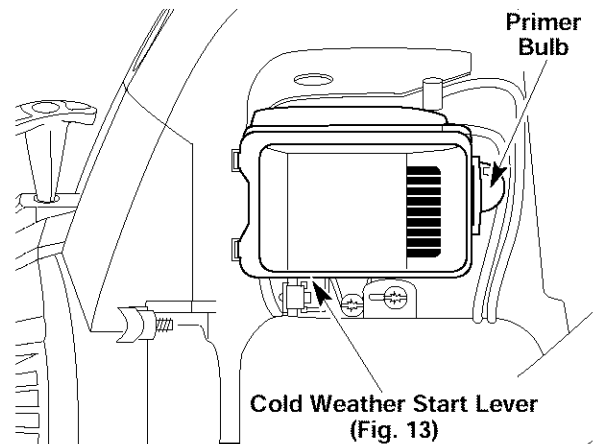

Fig. 11

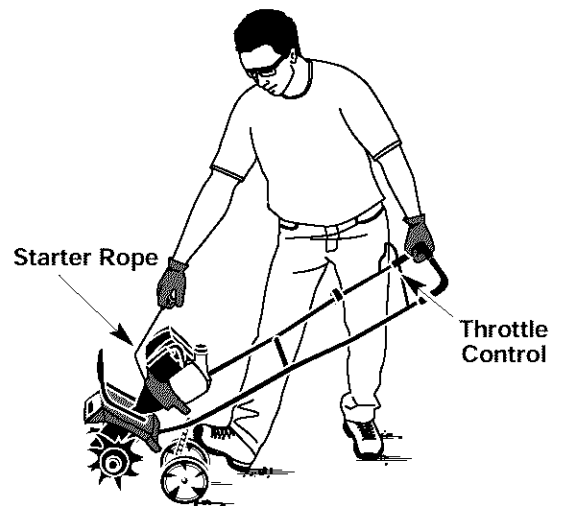

Fig. 12

STOPPING INSTRUCTIONS

1. Release your hand from the throttle control. Allow the engine to cool down by idling.
2. Put the On/Off Stop Control in the OFF (O) position.

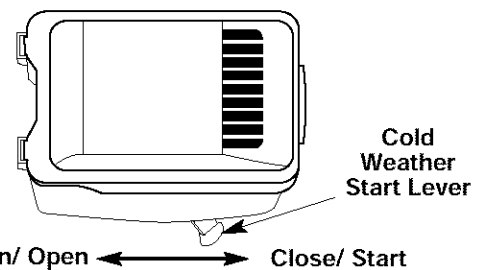

Fig. 13

OPERATING INSTRUCTIONS

OPERATING TIPS

	WARNING: Dress properly to reduce the risk of injury when operating this unit. Do not wear loose clothing or jewelry. Wear eye and ear/hearing protection. Wear heavy long pants, boots and gloves. Do not wear short pants, sandals or operate barefoot.
---	--

1. Move the cultivator to the work area prior to starting the engine. Transport the cultivator by pushing it on wheels or carrying it by the handle center tube.

	WARNING: To prevent serious personal injury, never pick-up or carry the unit while the engine is running.
---	--

2. Start the unit by following the *Starting Instructions*.
3. With the engine running and the tines off the ground, depress the throttle control to increase the engine speed.
4. While holding the upper handle with both hands, slowly lower the cultivator until the tines make contact with the ground (Fig. 14).
5. As cultivating action begins, tilt the cultivator up slightly using the handle so that the tines can penetrate the ground.
6. Once the ground has been broken, continue at a moderate pace until you are familiar with the controls and the handling of the cultivator.
7. If the tines are digging too deep or not deep enough, adjust the wheel bracket as described in *Adjusting Tine Depth*.



	WARNING: To prevent serious personal injury, use extreme caution when reversing or pulling the unit towards you.
---	---



Fig. 14

TRANSPORTING THE UNIT

	WARNING: To prevent serious personal injury, always stop the engine when operation is delayed or when transporting the unit from one location to another
--	---

1. Stop the engine.
2. Tilt the unit back until the tines clear the ground.
3. Push or pull the unit to the next location to be cultivated.

MAINTENANCE AND REPAIR INSTRUCTIONS

MAINTENANCE SCHEDULE

Perform these required maintenance procedures at the frequency stated in the table. These procedures should also be a part of any seasonal tune-up.

NOTE: Some maintenance procedures may require special tools or skills. If you are unsure about these procedures take your unit to any non-road engine repair establishment, individual or authorized service dealer.

NOTE: Maintenance, replacement, or repair of the emission control devices and system may be performed by any non-road engine repair establishment, individual or authorized service dealer.

	WARNING: To prevent serious injury, never perform maintenance or repairs with unit running. Always service and repair a cool unit. Disconnect the spark plug wire to ensure that the unit cannot start.
---	--

FREQUENCY	MAINTENANCE REQUIRED	REFER TO
Before starting engine	Fill fuel tank with fresh fuel Check oil	Page 9 Page 13
Every 10 hours	Clean and re-oil air filter	Page 14
First change at 10 hours Every 25 hours thereafter Every 25 hours	Change oil Change oil Clean spark arrestor	Page 13 Page 13 Page 17
10 hours on new engine Every 25 hours Every 25 hours	Check rocker arm to valve clearance and adjust Check rocker arm to valve clearance and adjust Check spark plug condition and gap	Page 15 Page 15 Page 17

TINE REMOVAL AND REPLACEMENT

All 4 tines should be replaced at the same time because they will wear evenly through normal use. Work on one side at a time.

	WARNING: To prevent serious personal injury, always wear heavy gloves when handling the tines.
---	---

1. Stop the unit and disconnect the spark plug wire.
- NOTE:** It may be necessary to lay the cultivator back in a horizontal position on a flat level surface with the upper handle touching the ground.
2. Remove the click pin from each end of the tine shaft. Slide the tines off of the shaft (Fig. 15).
 3. Clean and oil the shaft.
 4. Slide on the new tines with the hubs facing out. The four tines are marked with the letters "A" and "B."

5. Place one "A" tine and one "B" tine onto the shaft.
6. Secure the new tines to the shaft with click pins. It may be necessary to wash the dirt off the tines and shaft for ease of removal.

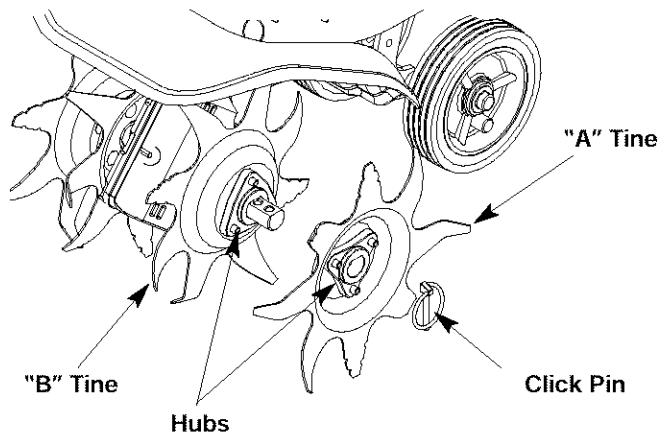
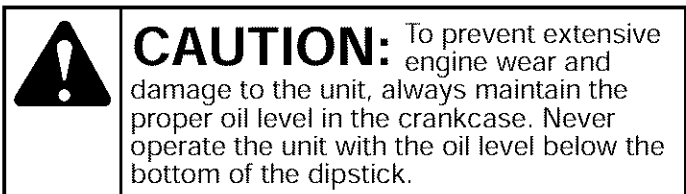

Fig. 15

MAINTENANCE AND REPAIR INSTRUCTIONS

CHECKING THE OIL LEVEL



The importance of checking and maintaining the proper oil level in the crankcase cannot be overemphasized. Check oil before each use:

1. Stop the engine and allow oil to drain into the crankcase.
2. Place the unit on a flat, level surface to get a proper oil level reading.
3. Keep dirt, grass clippings and other debris out of the engine. Clean the area around the oil fill plug/dipstick before removing it.
4. Remove the oil fill plug/dipstick and wipe off oil. Reinsert it all the way back in.
5. Remove the oil fill plug/dipstick and check the oil level. Oil should be up to the top of the dipstick (Fig. 16).

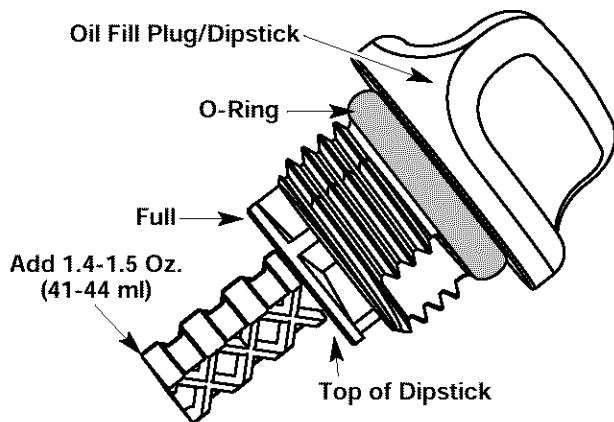

Fig. 16

6. If the level is low, add a small amount of oil to the oil fill hole and recheck (Fig. 17). Repeat this procedure until the oil level reaches the top of the dipstick.

NOTE: Do not overfill the unit.

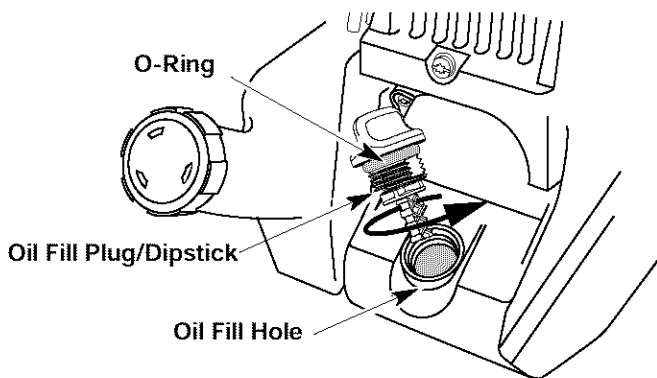

Fig. 17

NOTE: Make sure the O-ring is in place on the oil fill plug/dipstick when checking and changing the oil (Fig. 17).

CHANGING THE OIL

For a new engine, change the oil after the first 10 hours of operation. Change the oil while the engine is still warm. The oil will flow freely and carry away more impurities.



1. Unplug spark plug boot to prevent accidental starting.
2. Remove the oil fill plug/dipstick.
3. Pour the oil out of the oil fill hole and into a container by tipping the unit to a vertical position (Fig. 18). Allow ample time for complete drainage.

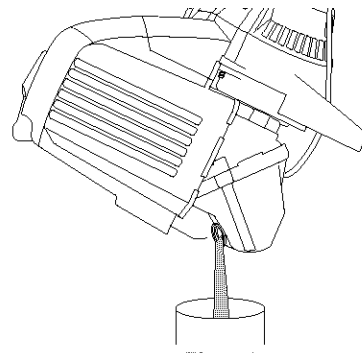

4. Wipe up any oil residue on the unit and clean up any oil that may have spilled. Dispose of the oil according to Federal, State and local regulations.
5. Refill the crankcase with 3.4 fluid ounce (100 ml) of SAE 30 SF, SG, SH oil.

NOTE: Use the bottle and spout saved from initial use to measure the correct amount of oil. The top of the label on the bottle measures approximately 3.4 ounces (100 ml). Check the level with the dipstick. If the level is low, add a small amount of oil and recheck. Do not overfill (Fig. 19).

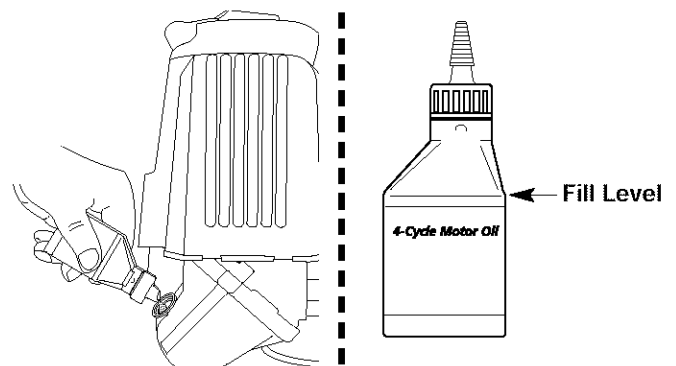

Fig. 19

6. Replace the oil fill plug/dipstick.
7. Reconnect the spark plug boot.

MAINTENANCE AND REPAIR INSTRUCTIONS

AIR FILTER MAINTENANCE

Cleaning the Air Filter

Clean and re-oil the air filter every 10 hours of operation. It is an important item to maintain. Failure to maintain the air filter will **VOID** the warranty.

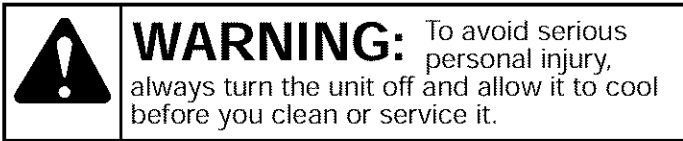

1. Open the air filter cover. Push the tab on the left side of the cover in, swing the air filter cover out and off the air filter housing (Fig. 20).
2. Remove the air filter and the screen that sits behind it (Fig. 20).

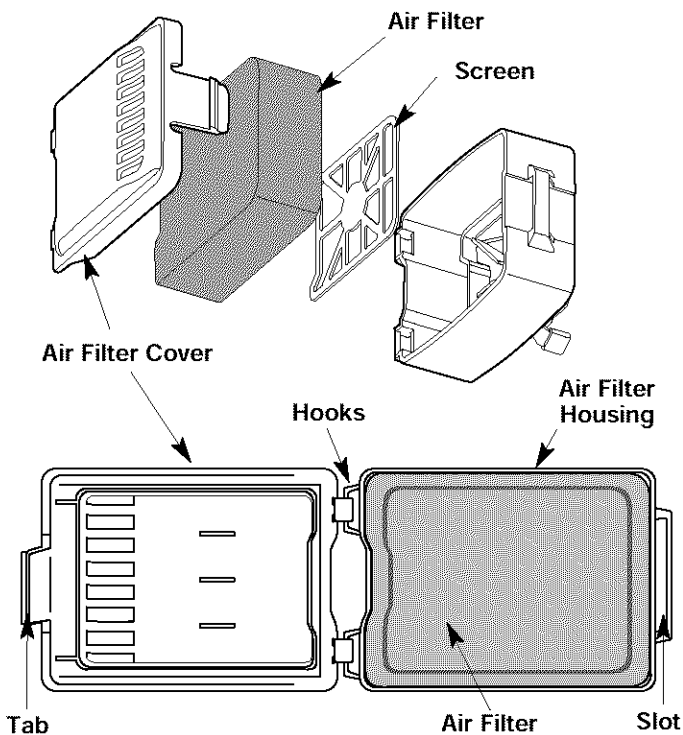

Fig. 20

3. Wash the filter in detergent and water (Fig. 21). Rinse the filter thoroughly and allow it to dry.

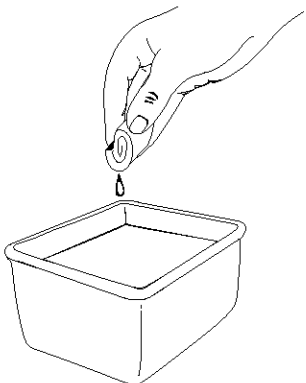

Fig. 21

4. Apply enough clean SAE 30 motor oil to lightly coat the filter (Fig. 22).

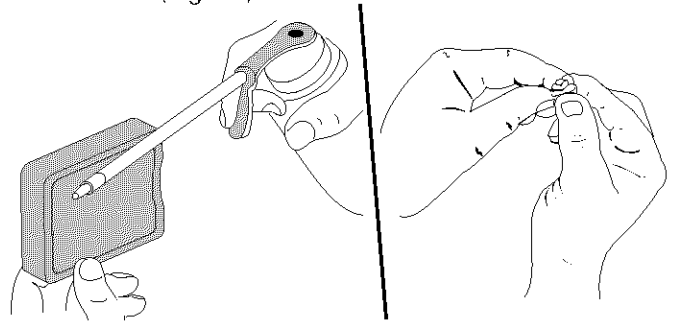

Fig. 22

5. Squeeze the filter to spread and remove excess oil (Fig. 22).
6. Replace the filter and screen (Fig. 20).

NOTE: If the unit is operated without the air filter, you will **VOID** the warranty.

7. Reinstall the air filter cover. Position the hooks on the left side of the air filter cover into the slots at the left side of the air filter housing.
8. Swing the cover to the right until the tab on the air filter cover snaps into place in the slot on the right side of the air filter housing (Fig. 20).

CARBURETOR ADJUSTMENT

The idle speed of the engine is adjustable. An idle adjustment screw is reached through a hole in the top of the engine cover (Fig. 23).

NOTE: Careless adjustments can seriously damage your unit. An authorized service dealer should make carburetor adjustments.

Check Fuel

Old fuel is usually the reason for improper unit performance. Drain and refill the tank with fresh fuel prior to making any adjustments. Refer to *Oil and Fuel Information*.

Clean Air Filter

The condition of the air filter is important to the operation of the unit. A dirty air filter will restrict air flow. This is often mistaken for an out of adjustment carburetor. Check the condition of the air filter before adjusting the idle speed screw. Refer to *Air Filter Maintenance*.

MAINTENANCE AND REPAIR INSTRUCTIONS

Adjust Idle Speed Screw



If, after checking the fuel and cleaning the air filter, the engine still will not idle, adjust the idle speed screw as follows:

1. Start the engine and let it run at a high idle for a minute to warm up. Refer to *Starting/Stopping Instructions*.

NOTE: Ensure the tines are not in contact with the ground when adjusting the idle.

2. Release the throttle trigger and let the engine idle. If the engine stops, insert a small phillips or flat blade screwdriver into the hole in the air filter/muffler cover (Fig. 23). Turn the idle speed screw in, **clockwise**, 1/8 of a turn at a time (as needed) until the engine idles smoothly.

NOTE: The tines should not rotate when the engine idles.

3. If the tines rotate when the engine idles, turn the idle speed screw **counterclockwise** 1/8 of a turn at a time (as needed), to reduce idle speed.

Checking the fuel, cleaning the air filter, and adjusting the idle speed should solve most engine problems. If not and all of the following are true:

- the engine will not idle
- the engine hesitates or stalls on acceleration
- there is a loss of engine power

Have the carburetor adjusted by an authorized service dealer.

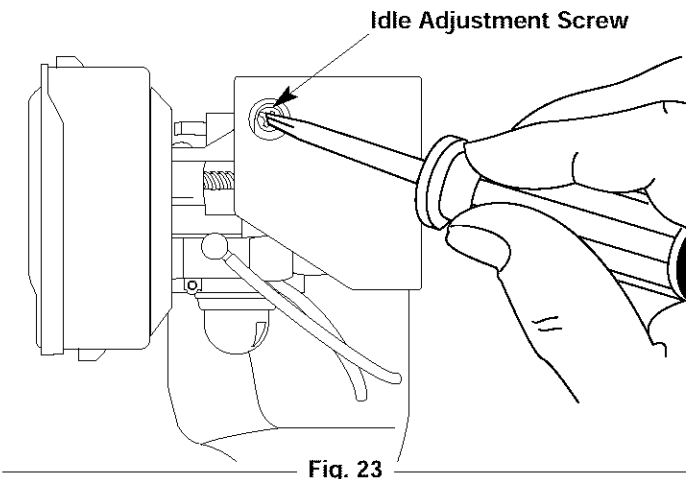

ROCKER ARM CLEARANCE

This requires disassembly of the engine. If you feel unsure or unqualified to perform this, take the unit to an authorized service center.

NOTE: Inspect the valve to rocker arm clearance with a feeler gauge after the first 10 hours of operation and then every 25 hours of operation thereafter.

- The engine must be cold when checking or adjusting the valve clearance.
- This task should be performed inside, in a clean, dust free area.

To adjust the rocker arm clearance:

1. Remove the two (2) screws on top of the engine cover with a Flat-head or T-25 Torx screwdriver (Fig. 24).

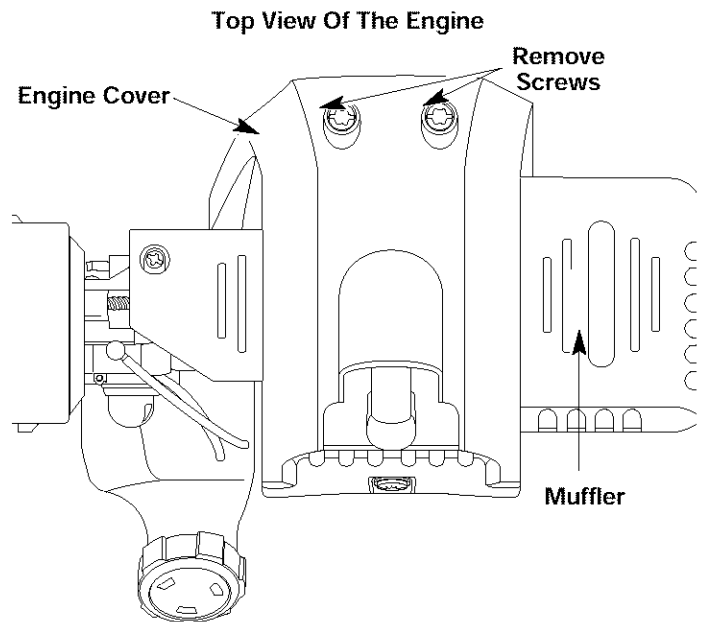

2. Remove the screw behind the engine cover (Fig. 25).

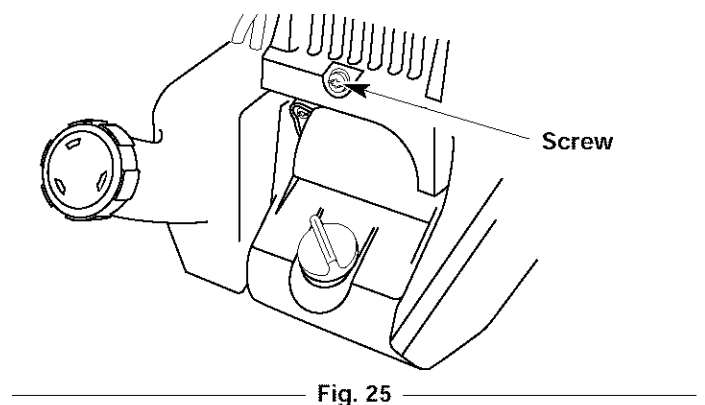

MAINTENANCE AND REPAIR INSTRUCTIONS

3. Disconnect the spark plug wire.
4. Clean dirt from around the spark plug. Remove the spark plug from the cylinder head by turning a 5/8 in. socket counterclockwise.
5. Remove the engine cover.

NOTE: To ease engine cover removal, pull the starter rope out a little to give some slack.

6. Clean dirt from around the rocker arm cover. Remove the screw holding the rocker arm cover with a large flat blade screwdriver or Torx T-25 bit (Fig. 26). Remove the rocker arm cover and gasket.

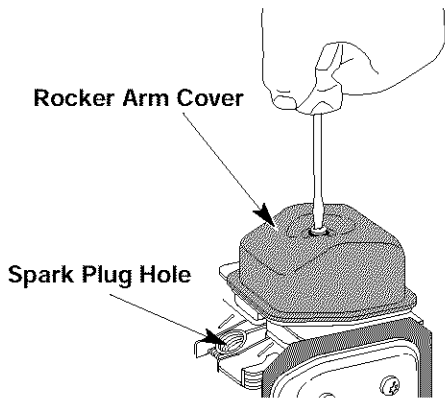

Fig. 26

7. Pull the starter rope slowly to bring the piston to the top of its travel, (known as top dead center). Check that:
 - The piston is at the top of its travel while looking in the spark plug hole (Fig. 26).
 - Both rocker arms move freely, both valves are closed
 If these statements are not true, repeat this step.
8. Slide the feeler gauge between the rocker arm and the valve return spring. Measure the clearance between the valve stem and rocker arm (Fig. 27 & 28). Measure both the intake and exhaust valves.

The recommended clearance for the intake is .003 – .006 in. (.076 – 0.152 mm). The recommended clearance for the exhaust is .013 – .016 in. (.330 – 0.406 mm).

Use a standard automotive feeler gauge at .005 and .015 in. (0.127 and 0.381 mm). The feeler gauge should slide between the rocker arm and valve stem with a slight amount of resistance, without binding. Figure 27 shows how to measure the intake clearance, while Figure 28 shows the exhaust clearance.

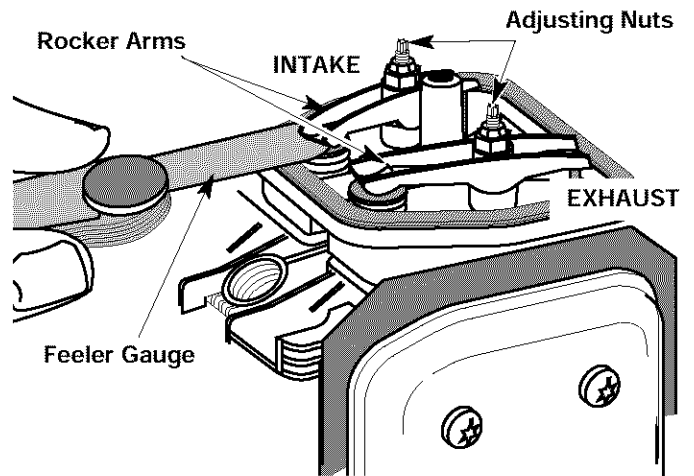

Fig. 27

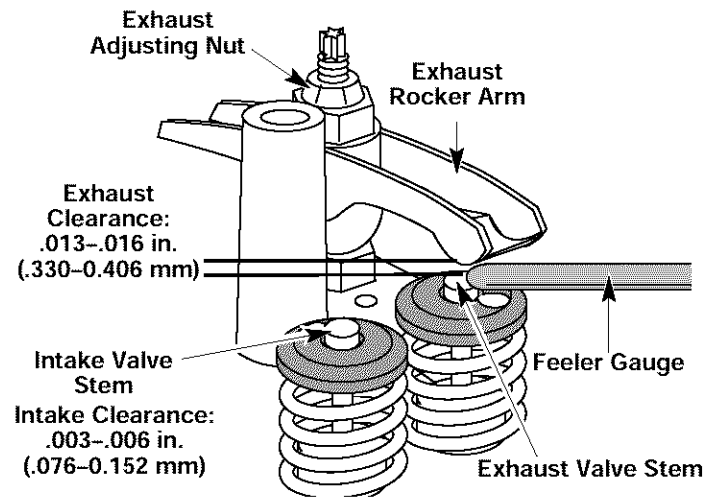

Fig. 28

9. If the clearance is not within specification:
 - a. Turn the adjusting nut using a 5/16 inch (8 mm) wrench or nut driver (Fig. 28).
 - To increase clearance, turn the adjusting nut counterclockwise.
 - To decrease clearance, turn the adjusting nut clockwise.
 - b. Recheck both clearances, and adjust as necessary.
10. Reinstall the rocker arm cover using a new gasket. Torque the screw to 20–30 in·lb (2.2–3.4 N·m).
11. Reinstall the engine cover. Check alignment of the cover before tightening the screws. Tighten screws.
12. Check the spark plug and reinstall. See *Replacing the Spark Plug*.
13. Replace the spark plug wire.

MAINTENANCE AND REPAIR INSTRUCTIONS

REPLACING THE SPARK PLUG

Use a replacement part number 180852 spark plug. The correct air gap is 0.025 in. (0.655 mm.). Remove the plug after every 25 hours of operation and check its condition.

1. Stop the engine and allow it to cool. Grasp the plug wire firmly and pull the cap from the spark plug.
2. Clean dirt from around the spark plug. Remove the spark plug from the cylinder head by turning a 5/8 in. socket counterclockwise.
3. Replace cracked, fouled or dirty spark plug. Set the air gap at 0.025 in. (0.655 mm.) using a feeler gauge (Fig. 29).

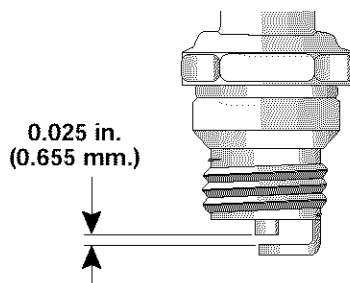

Fig. 29

	<p>WARNING: Do not sand blast, scrape or clean electrodes. Grit in the engine could damage the cylinder.</p>
--	---

4. Install a correctly-gapped spark plug in the cylinder head. Turn the 5/8 in. socket clockwise until snug.

If using a torque wrench torque to:
110-120 in.·lb. (12.3-13.5 N·m)

Do not over tighten.

SPARK ARRESTOR MAINTENANCE

1. Remove the muffler cover. See *Rocker Arm Clearance*.
2. With a flat blade screwdriver or Torx T-20 bit, remove the screw attaching the spark arrestor cover to the muffler (Fig. 30).

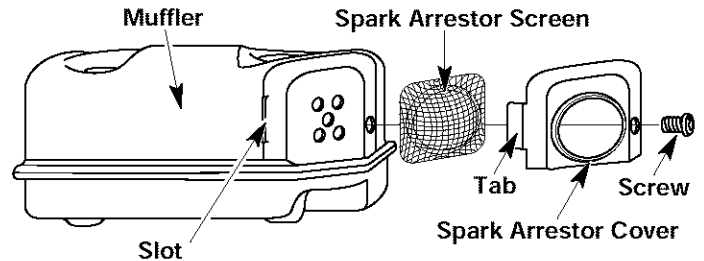

Fig. 30

3. Pull the tab on the spark arrestor cover out of the muffler. Remove the spark arrestor cover.
4. Remove the spark arrestor screen from the spark arrestor cover.
5. Clean the spark arrestor screen with a wire brush or replace it.
6. Reinstall the spark arrestor screen, spark arrestor cover and screw.

MAINTENANCE AND REPAIR INSTRUCTIONS

CLEANING THE UNIT



WARNING: To avoid serious personal injury, always turn the unit off and allow it to cool before you clean or perform any maintenance on it.

- Use a small brush to clean off the outside of the unit and to keep the air vents free of obstructions.
- Do not use strong detergents or petroleum based cleaners, such as kerosene. Some household cleaners contain aromatic oils such as pine and lemon that can damage the plastic housings or handles. Wipe off any moisture with a soft cloth.

STORAGE

- Never store the unit with fuel in the tank where fumes may reach an open flame or spark.
- Allow the engine to cool before storing.
- Store the unit in a locked up area to prevent unauthorized use or damage.
- Store the unit in a dry, well-ventilated area. Do not store next to corrosive material like fertilizer.
- Store the unit out of the reach of children.

LONG TERM STORAGE

If the unit will be stored for an extended time:

1. Drain all gasoline from the gas tank into a container. Do not use gas that has been stored for more than 60 days. Dispose of the old gasoline in accordance with Federal, State and Local regulations.

2. Start the engine and allow it to run until it stalls. This ensures that all gasoline has been drained from the carburetor.
3. Allow the engine to cool. Remove the spark plug and put 1 oz. (30 ml) of high quality motor oil into the cylinder. Pull the starter rope slowly to distribute the oil. Reinstall the spark plug.

NOTE: Remove the spark plug and drain all of the oil from the cylinder before attempting to start the unit after storage.

4. Change the oil, referring to the *Changing the Oil* section. Dispose of the old oil in accordance with Federal, State and Local regulations.
5. Thoroughly clean the unit and inspect for any loose or damaged parts. Repair or replace damaged parts and tighten loose screws, nuts or bolts.
6. To take up less storage area, loosen the handlebar knobs and fold the handlebar down. The unit is ready for storage.

TRANSPORTING

- Allow the engine to cool before transporting.
- Secure the unit while transporting.
- Drain the fuel tank before transporting.
- Tighten fuel cap before transporting.

TROUBLESHOOTING

ENGINE WILL NOT START

CAUSE

Empty fuel tank
Primer bulb wasn't pressed enough
Old fuel
Fouled spark plug
Plugged spark arrestor

When it is above 40°F outside, & the Cold Weather Start Lever is incorrectly in the CLOSED position

When it is below 40°F outside, & the Cold Weather Start Lever is incorrectly in the OPEN position

ACTION

Fill fuel tank with new fuel
Press primer bulb fully and slowly 10 times
Drain gas tank and add fresh fuel
Replace or clean the spark plug
Clean or replace spark arrestor

Flip the Cold Weather Start Lever to OPEN

Flip the Cold Weather Start Lever to CLOSED and follow the *Starting Instructions*

ENGINE WILL NOT IDLE

CAUSE

Air filter is plugged
Old fuel
Improper carburetor adjustment

ACTION

Replace or clean the air filter
Drain gas tank and add fresh fuel
Adjust carburetor

ENGINE WILL NOT ACCELERATE

CAUSE

Old fuel
Improper carburetor adjustment
Tines bound with grass
Dirty air filter
Plugged spark arrestor

ACTION

Drain gas tank and add fresh fuel
Take to an authorized service dealer for adjustment
Stop the engine and clean the tines
Clean or replace the air filter
Clean or replace spark arrestor

If further assistance is required, contact your authorized service dealer.

SPECIFICATIONS

ENGINE*

Engine Type.....	Air-Cooled, 4-Cycle
Displacement.....	1.6 cu. in. (26.2 cc)
Idle Speed RPM	3,200-3,600 rpm
Operating RPM.....	7,200-8,800 rpm
Clutch Type	Centrifugal
Ignition Type.....	Electronic
On/Off Stop Control.....	Rocker Switch
Valve clearance (intake)003-.006 in. (.076-.152 mm)
Valve clearance (exhaust)013-.016 in. (.330-.406 mm)
Spark Plug Gap	0.025 inch (0.655 mm)
Lubrication	SAE 30 Oil
Crankcase Oil Capacity	3.4 oz (100 ml)
Fuel	Unleaded
Carburetor	Diaphragm, All-Position
Starter	Auto Rewind
Muffler	Baffled with Guard
Throttle.....	Spring Return
Fuel Tank Capacity.....	15 oz (444 ml)

CULTIVATOR*

Cultivating Path Width (Maximum)	9 inches (22.86 cm)
Cultivating Depth (Maximum)	6 inches (15.24 cm)
Approximate Weight (no fuel)	25 lb. (11.5 kg)

*All specifications are based on the latest product information available at the time of printing. We reserve the right to make changes at any time without notice.

California / EPA Emission Control Warranty Statement

Your Warranty Rights and Obligations

The California Air Resources Board, EPA (Environmental Protection Agency), and Troy-Bilt LLC are pleased to explain the emission Control System Warranty on your 2000 and later small off-road engine. In California and the 49 states, new small off-road engines must be designed, built and equipped to meet the state's stringent anti-smog standards. Troy-Bilt must warrant the emission control system on your small off-road engine for the periods of time listed below provided there has been no abuse, neglect or improper maintenance of your small off-road engine.

Your Emission control system may include parts such as the carburetor or fuel-injection system, the ignition system, and catalytic converter. Also included may be hoses, belts, connectors and other emission-related assemblies.

Where a warrantable condition exists, Troy-Bilt will repair your small off-road engine at no cost to you including diagnosis, parts and labor.

The 2000 and later small off-road engines are warranted for two years. If any emission-related part on your engine is defective, the part will be repaired or replaced by Sears.

Owner's Warranty Responsibilities

- As the small off-road engine owner, you are responsible for the performance of the required maintenance listed in your operator's manual. Troy-Bilt recommends that you retain all receipts covering maintenance on your small off-road engine, but Troy-Bilt cannot deny warranty solely for the lack of receipts or for your failure to ensure the performance of all scheduled maintenance.
- As the small off-road engine owner, you should however be aware that Troy-Bilt may deny you warranty coverage if your small off-road engine or a part has failed due to abuse, neglect, improper maintenance or unapproved modifications.
- You are responsible for presenting your small off-road engine to a Troy-Bilt authorized service center as soon as problem exists. The warranty repairs should be completed in a reasonable amount of time, not to exceed 30 days.

If you have any questions regarding your warranty rights and responsibilities, you should call 1-800-520-5520.

Manufacturer's Warranty Coverage

- The warranty period begins on the date the engine or equipment is delivered to the retail purchaser.
- The manufacturer warrants to the initial owner and each subsequent purchaser, that the engine is free from defects in material and workmanship which cause the failure of a warranted part for a period of two years.
- Repair and replacement of warranted part will be performed at no charge to the owner at an authorized Troy-Bilt service center. For the nearest location please contact Troy-Bilt at: 1-800-520-5520.
- Any warranted part which is not scheduled for replacement, as required maintenance or which is scheduled only for regular inspection to the effect of "Repair or Replace as Necessary" is warranted for the period. Any warranted part which is scheduled for replacement as required maintenance will be warranted for the period of time up to the first scheduled replacement point for that part.
- The owner will not be charged for diagnostic labor which leads to the determination that a warranted part is defective. If the diagnostic work is performed at an authorized Troy-Bilt Service Center.
- The manufacturer is liable for damages to other engine components caused by the failure of a warranted part still under warranty.
- Failures caused by abuse, neglect or improper maintenance are not covered under warranty.
- The use of add-on or modified parts can be grounds for disallowing a warranty claim. The manufacturer is not liable to cover failures of warranted parts caused by the use of add-on or modified parts.
- In order to file a claim, go to your nearest authorized Troy-Bilt Service Center. Warranty service or repairs will be provided at all authorized Troy-Bilt Service Centers.
- Any manufacturer approved replacement part may be used in the performance of any warranty maintenance or repair of emission related parts and will be provided without charge to the owner. Any replacement part that is equivalent in performance or durability may be used in non-warranty maintenance or repair and will not reduce the warranty obligations of the manufacturer.
- The following components are included in the emission related warranty of the engine, air filter, carburetor, primer, fuel lines, fuel pick up/fuel filter, ignition module, spark plug and muffler.

PARTS LIST

ENGINE PARTS - MODEL TB144 4-CYCLE GAS CULTIVATOR

Part Numbers On Following Page

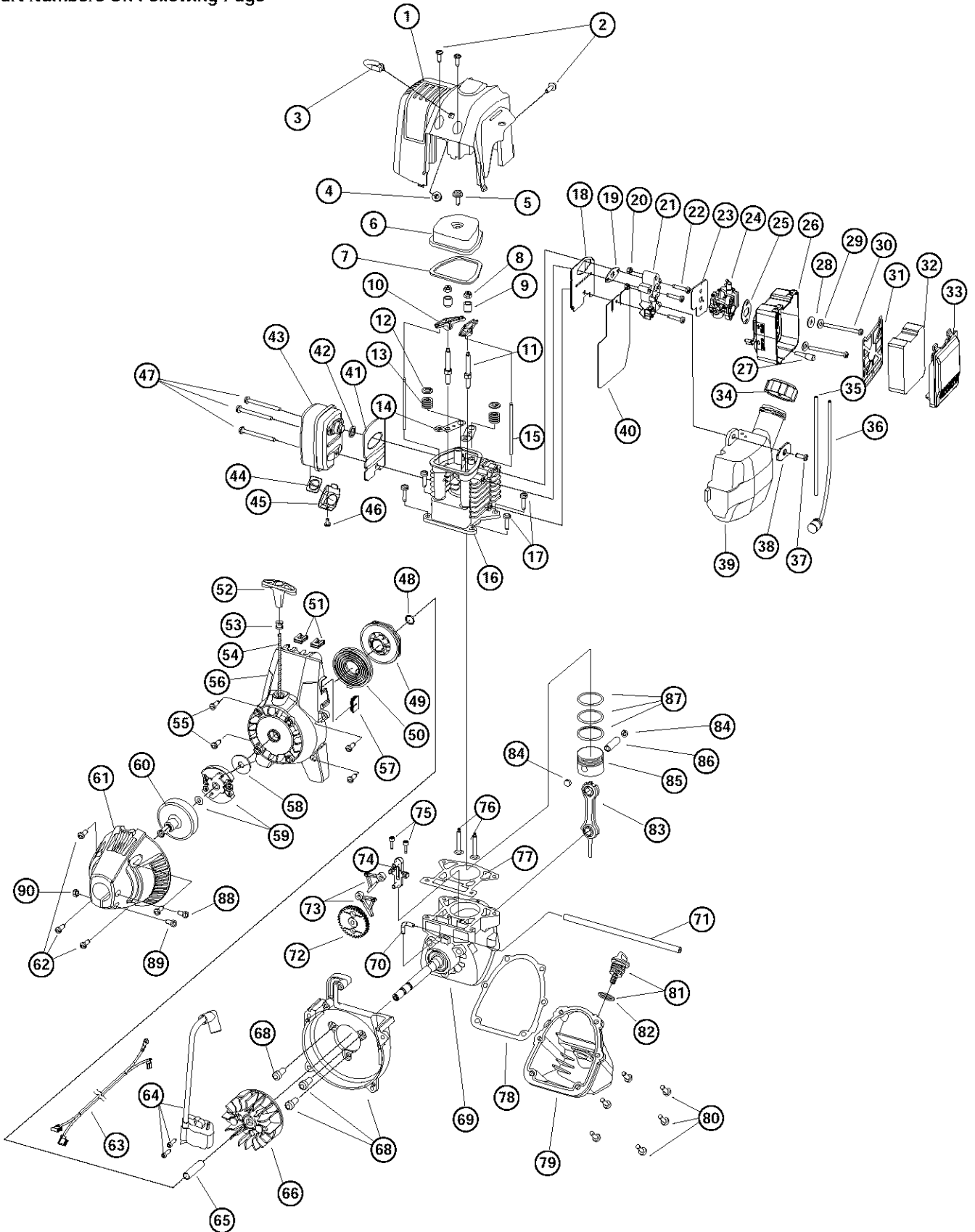

PARTS LIST

ENGINE PARTS - MODEL TB144 4-CYCLE GAS CULTIVATOR

<u>Item</u>	<u>Part No.</u>	<u>Description</u>	<u>Item</u>	<u>Part No.</u>	<u>Description</u>
1	753-04028	Engine Cover	48	753-04288	Palnut
2	791-182339	Engine Cover Screws	49	753-1199	Recoil Pulley
3	791-182651	Starter Rope Eyelet	50	753-04286	Recoil Spring
4	791-182652	Eyelet Nut	51	791-182366	Nut Clip
5	791-181025	Valve Cover Screw	52	791-181079	Pull Handle
6	791-182098	Valve Cover	53	791-611061	Rope Guide
7	791-182099	Valve Cover Gasket	54	791-613103	Rope
8	791-182340	Rocker Adjustment Nut	55	791-181020	Starter Housing Screw
9	791-182101	Rocker Arm Pivot	56	791-182662	Starter Housing Assembly (includes 48-55)
10	791-182100	Rocker Arm	57	791-182537	Wire Grommet
11	791-182341	Rocker Arm Stud	58	791-182368	Clutch Washer
12	791-182103	Valve Spring Retainer	59	753-1238	Clutch with Washer
13	791-181038	Valve Spring	60	791-153592	Clutch Drum
14	791-182102	Push Rod Guide	61	753-1239	Clutch Cover
15	791-181033	Push Rod	62	791-181345	Clutch Cover Screw
16	791-182745	Cylinder Assembly (includes 11-14)	63	753-04039	Lead Wire
17	791-182344	Cylinder Screw	64	753-04040	Ignition Module with Screws
18	792-182345	Intake Baffle	65	791-181065	Spacer
19	791-182749	Carburetor Mount Gasket	66	791-182736	Flywheel
20	791-181034	Nut	67	791-181861	Screw
21	753-04029	Carburetor Mount (includes 20)	68	791-182743	Shroud Assembly with Screws (includes 67)
22	791-182348	Carburetor Mount Screw	69	791-182376	Crankcase Assembly (includes 70 & 71)
23	791-182732	Carburetor Gasket	70	791-182375	90° Elbow
24	753-04296	Carburetor with Primer	71	791-182379	Breather Hose
25	753-04030	Air Filter Gasket	72	791-181015	Cam Gear
26	753-04492	Air Filter Cover Assembly (includes 27, 28, 31-33)	73	753-1242	Cam Follower
27	791-182097	Breather Tube Assembly	74	791-181013	Cam Bracket
28	791-181000	Grommet Washer	75	791-181012	Cam Bracket Screw
29	791-182409	Washer	76	791-181040	Valves, Intake and Exhaust
30	753-04031	Air Filter Mounting Screw	77	791-182374	Cylinder Gasket
31	791-182657	Air Filter Plate	78	791-181018	Oil Pan Gasket
32	791-182658	Air Filter	79	791-182377	Oil Pan (includes 78 & 80)
33	791-182659	Air Filter Cover	80	791-181020	Oil Pan Screw
34	753-1229	Fuel Cap	81	753-04041	Dipstick Assembly (includes 82)
35	791-182352	Fuel Return Line	82	791-182290	O-Ring
36	791-182353	Fuel Pick-Up Line with Filter	83	791-181009	Connecting Rod
37	791-181080	Screw	84	791-181008	Wrist Pin Button
38	753-04035	Washer	85	753-1243	Piston
39	791-182660	Fuel Tank Assembly (includes 34-36)	86	791-181006	Wrist Pin
40	791-182356	Fuel Tank Shield	87	791-181005	Piston Ring Set
41	753-1232	Muffler Baffle	88	791-145569	Anit-Rotation Screw
42	791-181048	Muffler Gasket	89	753-1240	Screw
43	753-0436	Muffler (includes 42, 44-46)	90	753-1241	Nut
44	791-180890	Spark Arrestor Screen	*	791-180852	Spark Plug
45	791-181045	Screen Cover	*	753-04087	Short Block Assembly (includes 5-17, 69-87)
46	791-181046	Screw	*	791-180142	Starter Pawl Repair Kit
47	791-182361	Muffler Mounting Screw	*	753-04014	Carburetor Repair Kit
			*	753-1248	Gasket/Diaphragm Repair Kit
			*		Parts not shown

PARTS LIST

BOOM AND CULTIVATOR PARTS - MODEL TB144 4-CYCLE GAS CULTIVATOR

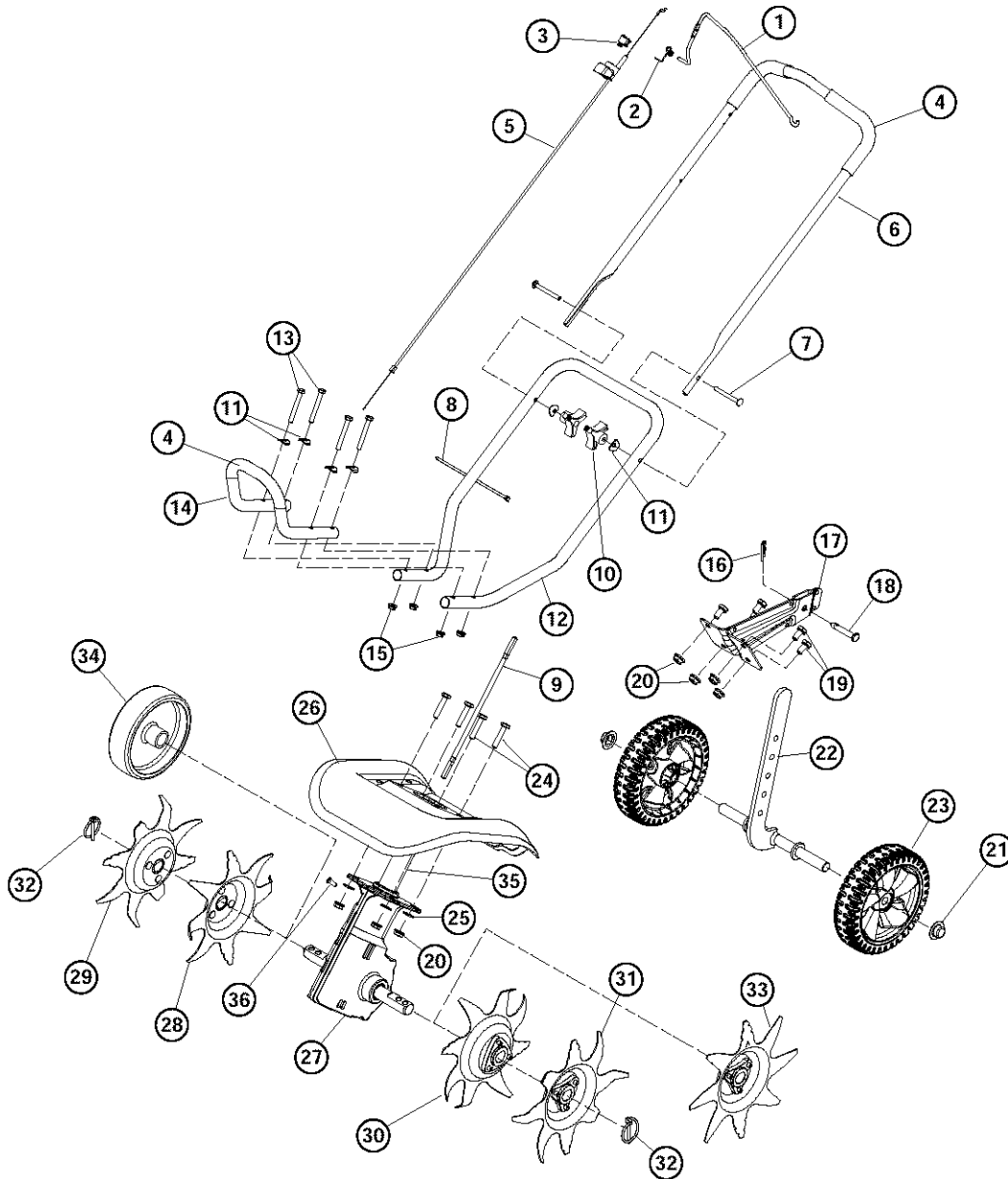

Item	Part No.	Description	Item	Part No.	Description
1	753-04042	Trottle Control	19	753-04060	Cap Screw
2	753-04043	Torsion Spring	20	753-04061	Lock Nut
3	791-182405	On/Off Switch	21	753-04062	Cap Push
4	753-04044	Foam Grip	22	753-04063	Wheel Support Bracket Assembly
5	753-04496	Throttle Cable	23	753-04501	Wheel
6	753-04498	Upper Handle	24	753-04065	Cap Screw
7	791-182899	Bolt	25	791-182678	Washer
8	753-04049	Cable Tie	26	753-04502	Tine Shield
9	753-04499	Flex Shaft	27	753-04075	Gear Box Assembly
10	753-182677	Knob	28	753-04074	Inner Tine (right side)
11	753-04052	Shoulder Washer	29	753-04073	Outer Tine (right side)
12	753-04053	Lower Handle	30	753-04072	Inner Tine (left side)
13	753-04054	Screw	31	753-04071	Outer Tine (left side)
14	753-04055	Front Handle	32	753-04070	Click Pin
15	753-04056	Lock Nut	33	753-04069	Edger Tine
16	753-04057	Cotter Pin	34	753-04068	Edger Wheel
17	753-04058	Tailpiece Bracket Assembly	35	753-04076	Drive Shaft Housing
18	753-04059	Clevis Pin	36	753-04077	Anti Rotation Screw

MANUFACTURER'S LIMITED WARRANTY FOR:



The limited warranty set forth below is given by Troy-Bilt LLC with respect to new merchandise purchased and used in the United States, its possessions and territories.

Troy-Bilt LLC warrants this product against defects in material and workmanship for a period of two (2) years commencing on the date of original purchase and will, at its option, repair or replace, free of charge, any part found to be defective in material or workmanship. This limited warranty shall only apply if this product has been operated and maintained in accordance with the Operator's Manual furnished with the product, and has not been subject to misuse, abuse, commercial use, neglect, accident, improper maintenance, alteration, vandalism, theft, fire, water or damage because of other peril or natural disaster. Damage resulting from the installation or use of any accessory or attachment not approved by Troy-Bilt LLC for use with the product(s) covered by this manual will void your warranty as to any resulting damage. This warranty is limited to ninety (90) days from the date of original retail purchase for any Troy-Bilt product that is used for rental or commercial purposes, or any other income-producing purpose.

HOW TO OBTAIN SERVICE: Warranty service is available, WITH PROOF OF PURCHASE THROUGH YOUR LOCAL AUTHORIZED SERVICE DEALER. To locate the dealer in your area, visit our website at www.troybilt.com, check for a listing in the Yellow Pages, call **1-800-520-5520** or write to P.O. Box 361131, Cleveland, OH 44136-0019.

This limited warranty does not provide coverage in the following cases:

- A. Tune-ups - Spark Plugs, Carburetor Adjustments, Filters
- B. Wear items - Bump Knobs, Outer Spools, Cutting Line, Inner Reels, Starter Pulley, Starter Ropes, Drive Belts
- C. Troy-Bilt LLC does not extend any warranty for products sold or exported outside of the United States of America, its possessions and territories, except those sold through Troy-Bilt's authorized channels of export distribution.

Troy-Bilt LLC reserves the right to change or improve the design of any Troy-Bilt Product without assuming any obligation to modify any product previously manufactured.

No implied warranty, including any implied warranty of merchantability or fitness for a particular purpose, applies after the applicable period of express written warranty above as to the parts as identified. No other express warranty or guaranty, whether written or oral, except as mentioned above, given by any person or entity, including a dealer or retailer, with respect to any product shall bind Troy-Bilt LLC. During the period of the Warranty, the exclusive remedy is repair or replacement of the product as set forth above. (Some states do not allow limitations on how long an implied warranty lasts, so the above limitation may not apply to you.)

The provisions as set forth in this Warranty provide the sole and exclusive remedy arising from the sales. Troy-Bilt LLC shall not be liable for incidental or consequential loss or damages including, without limitation, expenses incurred for substitute or replacement lawn care services, for transportation or for related expenses, or for rental expenses to temporarily replace a warranted product. (Some states do not allow limitations on how long an implied warranty lasts, so the above limitation may not apply to you.)

In no event shall recovery of any kind be greater than the amount of the purchase price of the product sold. Alteration of the safety features of the product shall void this Warranty. You assume the risk and liability for loss, damage, or injury to you and your property and/or to others and their property arising out of the use or misuse or inability to use the product.

This limited warranty shall not extend to anyone other than the original purchaser, original lessee or the person for whom it was purchased as a gift.

How State Law Relates to this Warranty: This warranty gives you specific legal rights, and you may also have other rights which vary from state to state.

To locate your nearest service dealer dial **1-800-520-5520**.

Troy-Bilt LLC

P.O. Box 361131

Cleveland, OH 44136-0019