

Cub Cadet®

Operator's Manual

Series 1500

Hydrostatic Lawn Tractor

Models 1525
1527

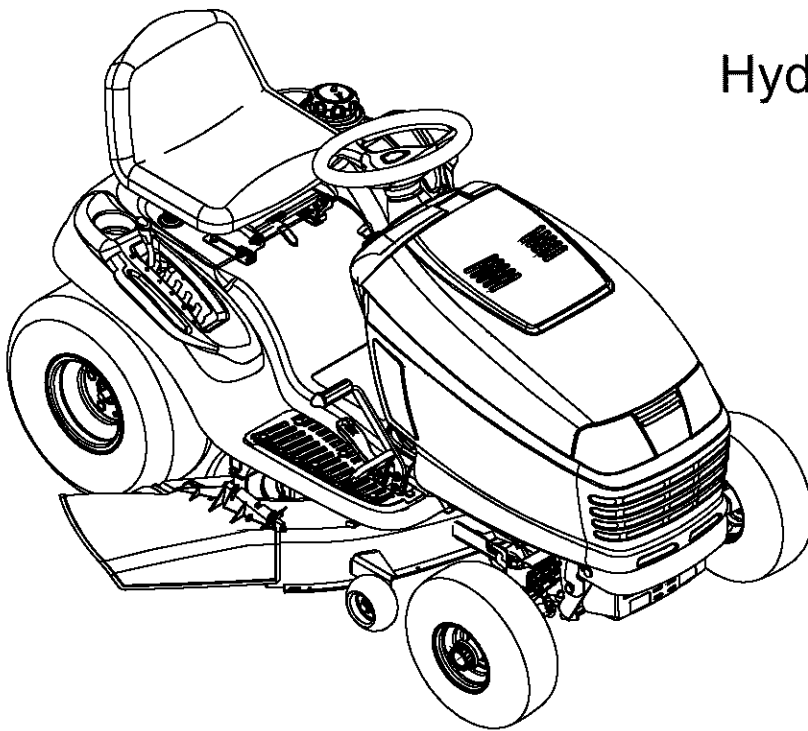

IMPORTANT: READ SAFETY RULES AND INSTRUCTIONS CAREFULLY

Warning: This unit is equipped with an internal combustion engine and should not be used on or near any unimproved forest-covered, brush-covered or grass-covered land unless the engine's exhaust system is equipped with a spark arrester meeting applicable local or state laws (if any). If a spark arrester is used, it should be maintained in effective working order by the operator. In the State of California the above is required by law (Section 4442 of the California Public Resources Code). Other states may have similar laws. Federal laws apply on federal lands. A spark arrester for the muffler is available through your Cub Cadet dealer or contact the service department, P.O. Box 361131 Cleveland, Ohio 44136-0019.

CUB CADET LLC, P.O. BOX 361131 CLEVELAND, OHIO 44136-0019

PRINTED IN U.S.A.

FORM NO. 769-00580

11/02

TABLE OF CONTENTS

Content	Page
Important Safe Operation Practices	3
Slope Gauge	7
Tractor Set-up	8
Know Your Lawn Tractor	9
Operating Your Lawn Tractor	12
Making Adjustments	16
Maintaining Your Lawn Tractor.....	19
Service	24
Off-Season Storage	29
Maintenance Chart.....	29
Troubleshooting	30
Specifications	31
Attachments & Accessories.....	32
Warranty Information.....	33

FINDING MODEL NUMBER

This Operator's Manual is an important part of your new lawn tractor. It will help you assemble, prepare and maintain the unit for best performance. Please read and understand what it says.



Before you start assembling your new equipment, please locate the model plate on the equipment and copy the information from it in the space provided below. The information on the model plate is very important if you need help from your *Cub Cadet* dealer.

- You can locate the model number by looking beneath the seat. A sample model plate is explained below. For future reference, please copy the model number and the serial number of the equipment in the space below.

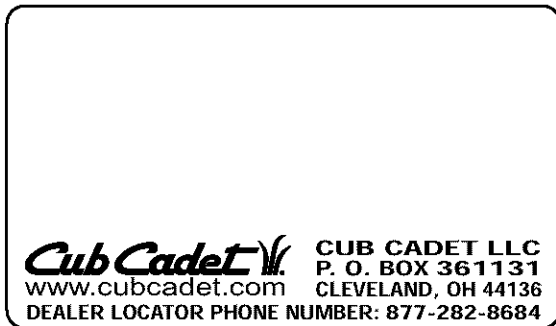

Copy the model number here: _____

Copy the serial number here: _____

CALLING CUSTOMER SUPPORT

If you have difficulty assembling this product or have any questions regarding the controls, operation or maintenance of this unit, please call the Customer Dealer Referral Line.



Call 1- (877) 282-8684 to reach the Customer Dealer Referral Line. Please have your unit's model number and serial number ready when you call. See previous section to locate this information.

For more details about your unit, visit our website at www.cubcadet.com

SECTION 1: IMPORTANT SAFE OPERATION PRACTICES



WARNING: This symbol points out important safety instructions which, if not followed, could endanger the personal safety and/or property of yourself and others. Read and follow all instructions in this manual before attempting to operate this machine. Failure to comply with these instructions may result in personal injury. When you see this symbol—heed its warning.



DANGER: This machine was built to be operated according to the rules for safe operation in this manual. As with any type of power equipment, carelessness or error on the part of the operator can result in serious injury. This machine is capable of amputating hands and feet and throwing objects. Failure to observe the following safety instructions could result in serious injury or death.

California Proposition 65 Warning:



WARNING: Engine exhaust, some of its constituents, and certain vehicle components contain or emit chemicals known to the State of California to cause cancer and birth defects or other reproductive harm.

GENERAL OPERATION

1. Read, understand, and follow all instructions on the machine and in the manual(s) before attempting to assemble and operate. Keep this manual in a safe place for future and regular reference and for ordering replacement parts.
2. Be familiar with all controls and their proper operation. Know how to stop the machine and disengage them quickly.
3. Never allow children under 14 years old to operate this machine. Children 14 years old and over should read and understand the operation instructions and safety rules in this manual and should be trained and supervised by a parent.
4. Never allow adults to operate this machine without proper instruction.
5. To help avoid blade contact or a thrown object injury, keep bystanders, helpers, children and pets at least 75 feet from the machine while it is in operation. Stop machine if anyone enters the area.
6. Thoroughly inspect the area where the equipment is to be used. Remove all stones, sticks, wire, bones, toys, and other foreign objects which could be picked up and thrown by the blade(s). Thrown objects can cause serious personal injury.
7. Plan your mowing pattern to avoid discharge of material toward roads, sidewalks, bystanders and the like. Also, avoid discharging material against a wall or obstruction which may cause discharged material to ricochet back toward the operator.
8. Always wear safety glasses or safety goggles during operation and while performing an adjustment or repair to protect your eyes. Thrown objects which ricochet can cause serious injury to the eyes.
9. Wear sturdy, rough-soled work shoes and close-fitting slacks and shirts. Loose fitting clothes and jewelry can be caught in movable parts. Never operate this machine in bare feet or sandals.
10. Be aware of the mower and attachment discharge direction and do not point it at anyone. Do not operate the mower without the discharge cover or entire grass catcher in its proper place.
11. Do not put hands or feet near rotating parts or under the cutting deck. Contact with the blade(s) can amputate hands and feet.
12. A missing or damaged discharge cover can cause blade contact or thrown object injuries.
13. Stop the blade(s) when crossing gravel drives, walks, or roads and while not cutting grass.
14. Watch for traffic when operating near or crossing roadways. This machine is not intended for use on any public roadway.
15. Do not operate the machine while under the influence of alcohol or drugs.
16. Mow only in daylight or good artificial light.
17. Never carry passengers.
18. Disengage blade(s) before travelling in reverse. Back up slowly. Always look down and behind before and while backing to avoid a back-over accident.
19. Slow down before turning. Operate the machine smoothly. Avoid erratic operation and excessive speed.
20. Disengage blade(s), set parking brake, stop engine and wait until the blade(s) come to a complete stop before removing grass catcher, emptying grass, unclogging chute, removing any grass or debris, or making any adjustments.
21. Never leave a running machine unattended. Always turn off blade(s), place transmission in neutral, set parking brake, stop engine and remove key before dismounting.
22. Use extra care when loading or unloading the machine into a trailer or truck. This unit should not be driven up or down ramp(s), because the unit could tip over, causing serious personal injury. The unit must be pushed manually on ramp(s) to load or unload properly.

23. Muffler and engine become hot and can cause a burn. Do not touch.
24. Check overhead clearances carefully before driving under low hanging tree branches, wires, door openings etc., where the operator may be struck or pulled from the unit, which could result in serious injury.
25. Disengage all attachment clutches, depress the brake pedal completely before attempting to start engine.
26. Your machine is designed to cut normal residential grass of a height no more than 10". Do not attempt to mow through unusually tall, dry grass (e.g., pasture) or piles of dry leaves. Dry grass or leaves may contact the engine exhaust and/or build up on the mower deck presenting a potential fire hazard.
27. Use only accessories and attachments approved for this machine by the machine manufacturer. Read, understand and follow all instructions provided with the approved accessory or attachment.
28. Data indicates that operators, age 60 years and above, are involved in a large percentage of riding mower-related injuries. These operators should evaluate their ability to operate the riding mower safely enough to protect themselves and others from serious injury.
29. If situations occur which are not covered in this manual, use care and good judgment. Contact your *Cub Cadet* dealer for assistance.

SLOPE OPERATION

Slopes are a major factor related to loss of control and tip-over accidents which can result in severe injury or death. All slopes require extra caution. If you cannot back up the slope or if you feel uneasy on it, do not mow it.

For your safety, use the slope gauge included as part of this manual to measure slopes before operating this unit on a sloped or hilly area. If the slope is greater than 15 degrees as shown on the slope gauge, do not operate this unit on that area or serious injury could result.

DO:

1. Mow up and down slopes, not across. Exercise extreme caution when changing direction on slopes.
2. Watch for holes, ruts, bumps, rocks, or other hidden objects. Uneven terrain could overturn the machine. Tall grass can hide obstacles.
3. Use slow speed. Choose a low enough speed setting so that you will not have to stop while on the slope. Tires may lose traction on slopes even though the brakes are functioning properly. Always keep machine in gear when going down slopes to take advantage of engine braking action.
4. Follow the manufacturer's recommendations for wheel weights or counterweights to improve stability.
5. Use extra care with grass catchers or other attachments. These can change the stability of the machine.
6. Keep all movement on the slopes slow and gradual. Do not make sudden changes in speed or direction. Rapid engagement or braking could cause the front of the machine to lift and rapidly flip over backwards which could cause serious injury.
7. Avoid starting or stopping on a slope. If tires lose traction, disengage the blade(s) and proceed slowly straight down the slope.

DO NOT:

1. Do not turn on slopes unless necessary; then, turn slowly and gradually downhill, if possible.
2. Do not mow near drop-offs, ditches or embankments. The mower could suddenly turn over if a wheel is over the edge of a cliff, ditch, or if an edge caves in.
3. Do not try to stabilize the machine by putting your foot on the ground.
4. Do not use a grass catcher on steep slopes.
5. Do not mow on wet grass. Reduced traction could cause sliding.
6. Do not coast downhill. Over-speeding may cause the operator to lose control of the machine resulting in serious injury or death.
7. Do not tow heavy pull behind attachments (e.g. loaded dump cart, lawn roller, etc.) on slopes greater than 5 degrees. When going down hill, the extra weight tends to push the tractor and may cause you to lose control. (e.g. tractor may speed up, braking and steering ability are reduced, attachment may jack-knife and cause tractor to overturn).

CHILDREN

1. Tragic accidents can occur if the operator is not alert to the presence of children. Children are often attracted to the machine and the mowing activity. They do not understand the dangers. Never assume that children will remain where you last saw them.
 - a. Keep children out of the mowing area and in watchful care of a responsible adult other than the operator.
 - b. Be alert and turn machine off if a child enters the area.
 - c. Before and while backing, look behind and down for small children.
 - d. Never carry children, even with the blade(s) shut off. They may fall off and be seriously injured or interfere with safe machine operation.

- e. Use extreme care when approaching blind corners, doorways, shrubs, trees or other objects that may block your vision of a child who may run into the machine.
 - f. Disengage the cutting blade(s) before traveling in reverse. The "No-Cut-In Reverse" feature is a reminder not to cut in reverse and to help avoid back over accidents. Do not defeat it.
 - g. Keep children away from hot or running engines. They can suffer burns from a hot muffler.
 - h. Remove key when machine is unattended to prevent unauthorized operation.
9. Never allow children under 14 years old to operate the machine. Children 14 years old and over should read and understand the operation instructions and safety rules in this manual and should be trained and supervised by a parent.

TOWING

1. Tow only with a machine that has a hitch designed for towing. Do not attach towed equipment except at the hitch point.
2. Follow the manufacturers recommendation for weight limits for towed equipment and towing on slopes.
3. Never allow children or others in or on towed equipment.
4. On slopes, the weight of the towed equipment may cause loss of traction and loss of control.
5. Travel slowly and allow extra distance to stop.
6. Do not coast downhill.

SERVICE

SAFE HANDLING OF GASOLINE:

1. **To avoid personal injury or property damage** use extreme care in handling gasoline. **Gasoline** is extremely flammable and the vapors are explosive. Serious personal injury can occur when gasoline is spilled on yourself or your clothes which can ignite. Wash your skin and change clothes immediately.
 - a. Use only an approved gasoline container.
 - b. Never fill containers inside a vehicle or on a truck or trailer bed with a plastic liner. Always place containers on the ground away from your vehicle before filling.
 - c. When practical, remove gas-powered equipment from the truck or trailer and refuel it on the ground. If this is not possible, then refuel such equipment on a trailer with a portable container, rather than from a gasoline dispenser nozzle.
 - d. Keep the nozzle in contact with the rim of the fuel tank or container opening at all times until fueling is complete. Do not use a nozzle

lock-open device.

- e. Extinguish all cigarettes, cigars, pipes and other sources of ignition.
- f. Never fuel machine indoors.
- g. Never remove gas cap or add fuel while the engine is hot or running. Allow engine to cool at least two minutes before refueling.
- h. Never over fill fuel tank. Fill tank to no more than three inches below the top of the filler neck to allow space for fuel expansion.
- i. Replace gasoline cap and tighten securely.
- j. If gasoline is spilled, wipe it off the engine and equipment. Move unit to another area. Wait 5 minutes before starting the engine.
- k. To reduce fire hazards, keep machine free of grass, leaves, or other debris build-up. Clean up oil or fuel spillage and remove any fuel soaked debris.
- l. Never store the machine or fuel container inside where there is an open flame, spark or pilot light as on a water heater, space heater, furnace, clothes dryer or other gas appliances.
- m. Allow a machine to cool at least five minutes before storing.

GENERAL SERVICE:

1. Never run an engine indoors or in a poorly ventilated area. Engine exhaust contains carbon monoxide, an odorless, and deadly gas.
2. Before cleaning, repairing, or inspecting, make certain the blade(s) and all moving parts have stopped. Disconnect the spark plug wire and ground against the engine to prevent unintended starting.
3. Periodically check to make sure the blades come to complete stop within approximately (5) five seconds after operating the blade disengagement control. If the blades do not stop within the this time frame, your unit should be serviced professionally by an authorized *Cub Cadet* dealer.
4. Check brake operation frequently as it is subjected to wear during normal operation. Adjust and service as required.
5. Check the blade(s) and engine mounting bolts at frequent intervals for proper tightness. Also, visually inspect blade(s) for damage (e.g., excessive wear, bent, cracked). Replace the blade(s) with the original equipment manufacturer's (O.E.M.) blade(s) only, listed in this manual. "Use of parts which do not meet the original equipment specifications may lead to improper performance and compromise safety!"
6. Mower blades are sharp. Wrap the blade or wear gloves, and use extra caution when servicing them.
7. Keep all nuts, bolts, and screws tight to be sure the equipment is in safe working condition.

8. Never tamper with the safety interlock system or other safety devices. Check their proper operation regularly.
9. After striking a foreign object, stop the engine, disconnect the spark plug wire(s) and ground against the engine. Thoroughly inspect the machine for any damage. Repair the damage before starting and operating.
10. Never attempt to make adjustments or repairs to the machine while the engine is running.
11. Do not change the engine governor settings or over-speed the engine. The governor controls the maximum safe operating speed of the engine.
12. Maintain or replace safety and instruction labels, as necessary.
13. Observe proper disposal laws and regulations for gas, oil, etc. to protect the environment.
14. Grass catcher components and the discharge cover are subject to wear and damage which could expose moving parts or allow objects to be thrown. For safety protection, frequently check components and replace immediately with original equipment manufacturer's (O.E.M.) parts only, listed in this manual. "Use of parts which do not meet the original equipment specifications may lead to improper performance and compromise safety!"



WARNING: YOUR RESPONSIBILITY Restrict the use of this power machine to persons who read, understand and follow the warnings and instructions in this manual and on the machine.



WARNING

TO AVOID SERIOUS INJURY OR DEATH

- GO UP AND DOWN SLOPES, NOT ACROSS.
- AVOID SUDDEN TURNS.
- DO NOT OPERATE THE UNIT WHERE IT COULD SLIP OR TIP.
- IF MACHINE STOPS GOING UPHILL, STOP BLADE(S) AND BACK DOWNHILL SLOWLY.
- DO NOT MOW WHEN CHILDREN OR OTHERS ARE AROUND.
- NEVER CARRY CHILDREN EVEN WITH BLADES OFF.
- LOOK DOWN & BEHIND BEFORE AND WHILE BACKING.
- KEEP SAFETY DEVICES (GUARDS, SHIELDS, AND SWITCHES, ETC.) IN PLACE AND WORKING.
- REMOVE OBJECTS THAT COULD BE THROWN BY THE BLADE(S).
- KNOW LOCATION AND FUNCTION OF ALL CONTROLS.
- BE SURE BLADE(S) AND ENGINE ARE STOPPED BEFORE PLACING HANDS OR FEET NEAR BLADE(S)
- BEFORE LEAVING OPERATOR'S POSITION, DISENGAGE BLADE(S), ENGAGE PARKING BRAKE, SHUT OFF AND REMOVE KEY.

READ OPERATOR'S MANUAL

SECTION 2: SLOPE GAUGE

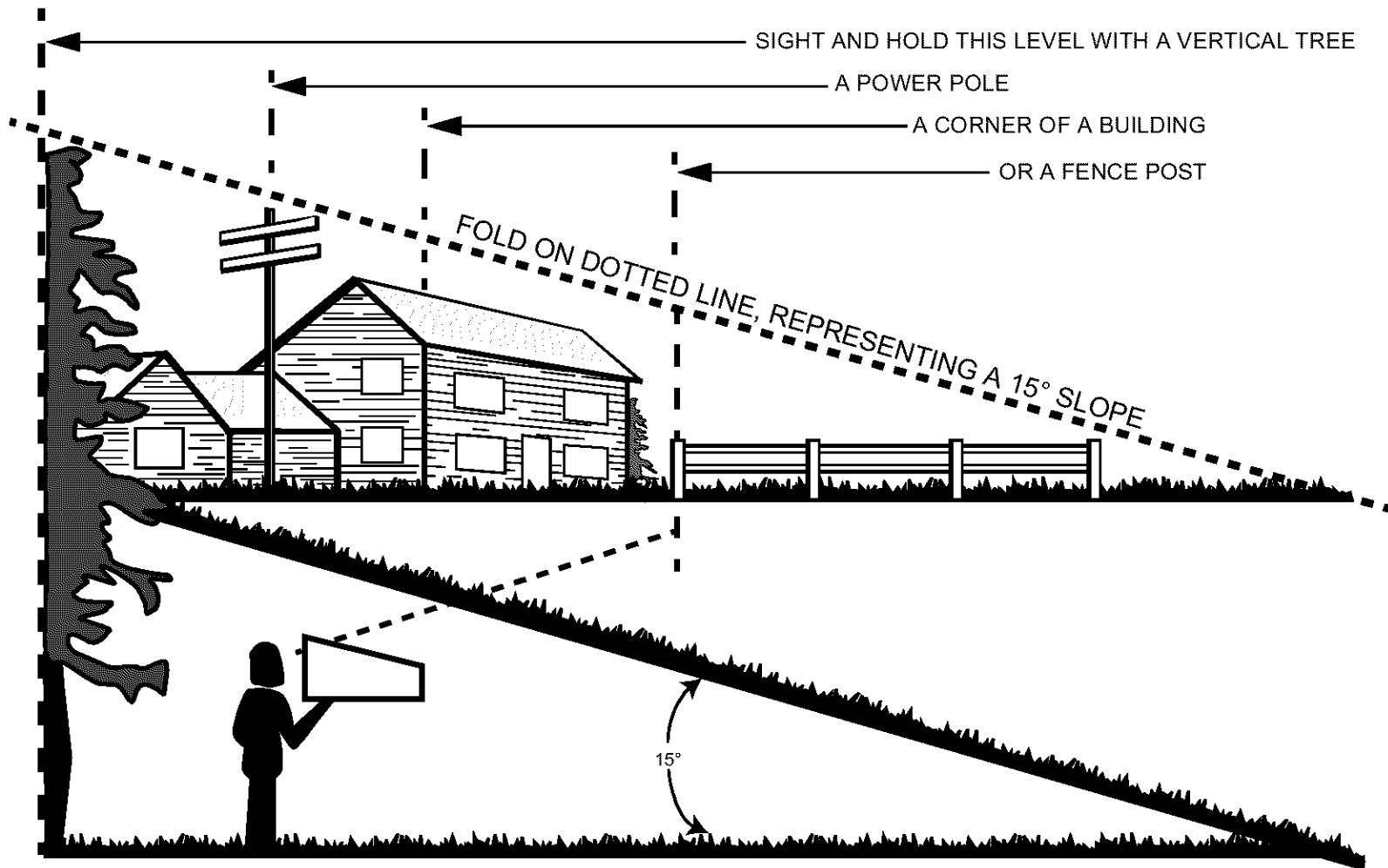

WARNING

Do not mow on inclines with a slope in excess of 15 degrees (a rise of approximately 2-1/2 feet every 10 feet). A riding mower could overturn and cause serious injury. If operating a walk-behind mower on such a slope, it is extremely difficult to maintain your footing and you could slip, resulting in serious injury. Operate RIDING mowers up and down slopes, never across the face of slopes.

SECTION 3: TRACTOR SET-UP

Attaching the Battery Cables

The positive battery terminal is marked Pos. (+). The negative battery terminal is marked Neg. (-).

- The positive cable (heavy red wire) is secured to the positive battery terminal (+) with a hex bolt and hex nut at the factory. Make certain that the rubber boot covers the terminal to protect it from corrosion.
- Lift the tractor's hood and remove the hex bolt and wing nut from the negative cable (thick black wire).
- Remove the black plastic cover, if present, from the negative battery terminal and attach the negative cable to the negative battery terminal (-) with the bolt and wing nut.

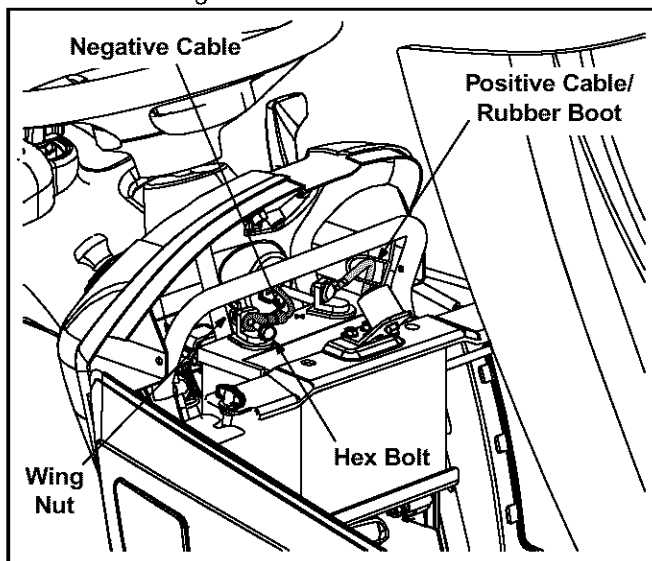

Figure 1

NOTE: If the battery is put into service after the date shown on top of battery, charge as instructed on page 25 of this manual prior to operating the tractor.

Gas and Oil Fill-up

The gasoline tank is located under the fender and has a capacity of three gallons. Unthread the fuel cap by turning it counterclockwise. Use only clean, fresh (under 30 days old), unleaded gasoline. Fill tank to no more than four inches below the top of the filler neck to allow space for fuel expansion. Do not overfill.



WARNING: Use extreme care when handling gasoline. Gasoline is extremely flammable and the vapors are explosive. Never fuel machine indoors or while the engine is hot or running. Extinguish cigarettes, cigars, pipes, and other sources of ignition.

IMPORTANT: Your tractor is shipped with oil in the engine. However, you **MUST** check the oil level before operating. Refer to **Checking the Oil Level** on page 19 for detailed instructions. Be careful not to overfill.

Shipping Brace Removal



WARNING: Make sure the riding mower's engine is off, set the parking brake and remove the ignition key before removing the shipping brace.

- Locate the shipping brace and warning tag found on the right side of the cutting deck. See Figure 2.

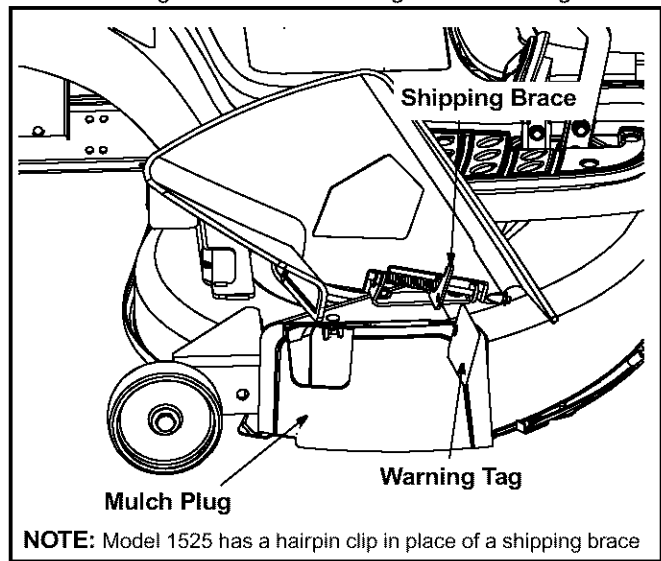

Figure 2

- While holding the discharge chute with your left hand, remove the shipping brace with your right hand by grasping it between your thumb and index finger and rotating it clockwise.

NOTE: Series 1500 tractors come equipped with a mulch plug installed inside the chute opening. Do NOT discard it. Refer to **Mulching** on page 16 for detailed information regarding your tractor's mulching feature.



WARNING: The shipping brace, used for packaging purposes only, must be removed and discarded before operating your riding mower.



WARNING: The mowing deck is capable of throwing objects. Failure to operate the riding mower without the discharge cover in the proper operating position could result in serious personal injury and/or property damage.

SECTION 4: KNOW YOUR LAWN TRACTOR

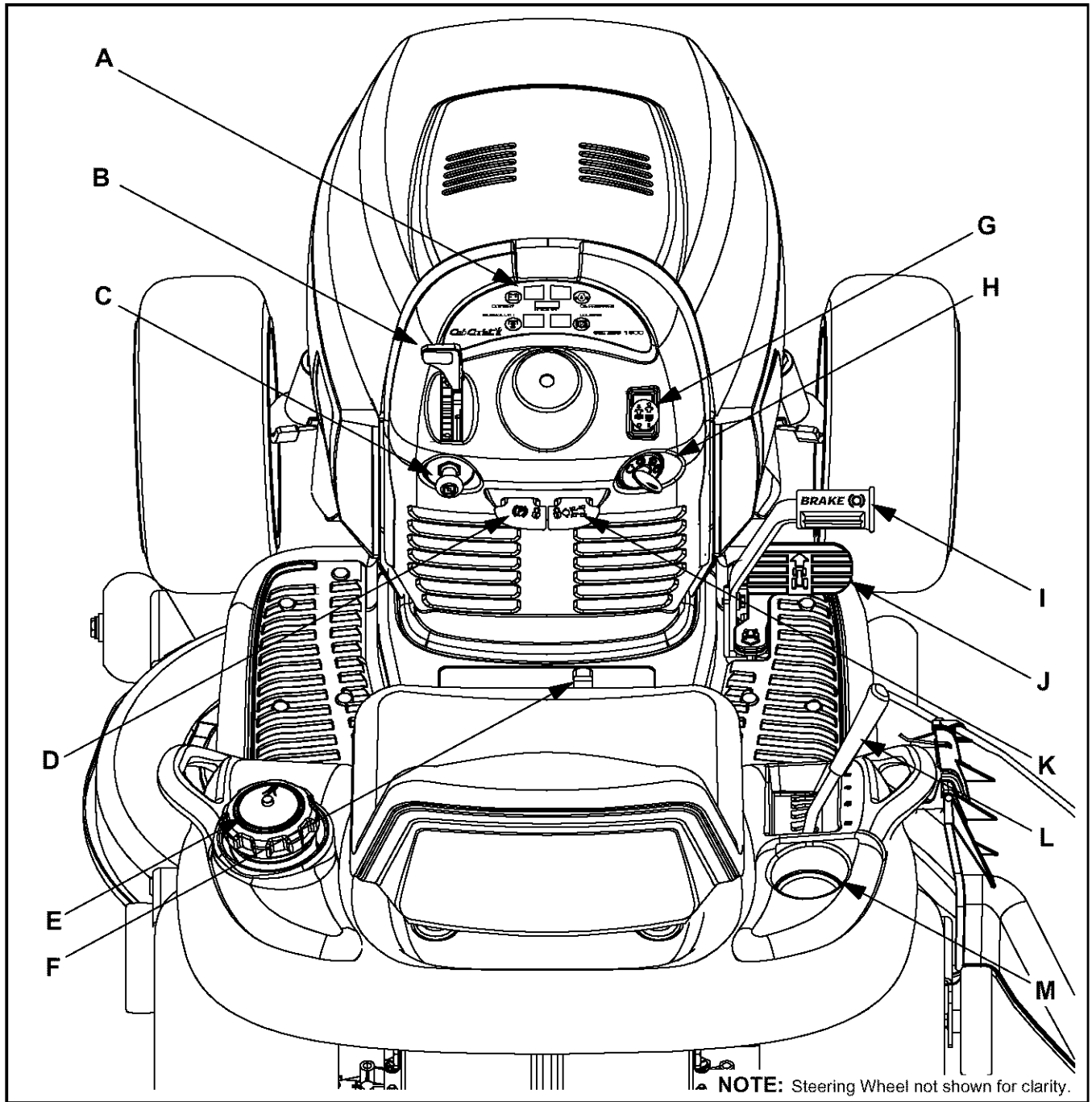

Figure 3

- | | | | |
|---|--------------------------------------|---|----------------------|
| A | Systems Indicator Monitor/Hour Meter | H | Ignition Switch |
| B | Throttle Control Lever | I | Brake Pedal |
| C | Choke Control | J | Drive Pedal |
| D | Parking Brake Lever | K | Cruise Control Lever |
| E | Fuel Tank Cap | L | Deck Lift Lever |
| F | Seat Adjustment Lever | M | Cup Holder |
| G | PTO (Power Take-off) Knob | | |

NOTE: Any reference in this manual to the RIGHT or LEFT side of the tractor is observed from operator's position.

Throttle Control Lever

The throttle control lever is located on the left side of the tractor's dash panel. This lever controls the speed of the engine. When set in a given position, the throttle will maintain a uniform engine speed. See Figure 4.

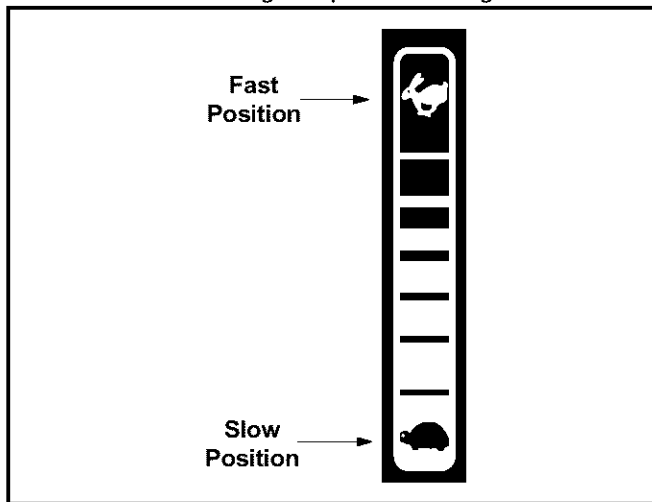
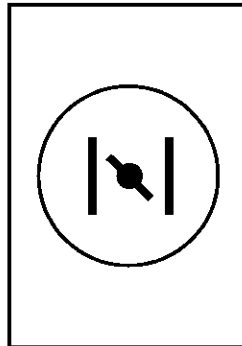

Figure 4

IMPORTANT: When operating the tractor with the cutting deck engaged, be certain that the throttle lever is **always** in the FAST (rabbit) position.

Choke Control

The choke control can be found on the left side of the dash panel and is activated by pulling the knob outward. Activating the choke control closes the choke plate on the carburetor and aids in starting the engine. Refer to **Starting The Engine** on page 13 of this manual for detailed starting instructions.



Brake Pedal

The brake pedal is located on the right front side of the tractor above the drive pedal along the running board. The brake pedal can be used to quickly stop the tractor or for setting the parking brake.

NOTE: The brake pedal must be fully depressed to activate the safety interlock switch when starting the tractor.

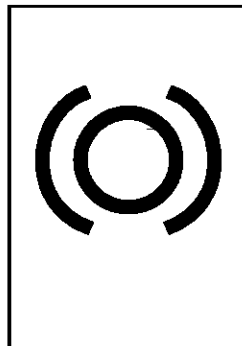

Ignition Switch



WARNING: Never leave a running machine unattended. Always disengage the PTO, set parking brake, stop engine and remove key to prevent unintended starting.

To start the engine, insert the key into the ignition switch and turn clockwise to the **START** position. Release the key into the **ON** position once engine has fired. See Figure 5.

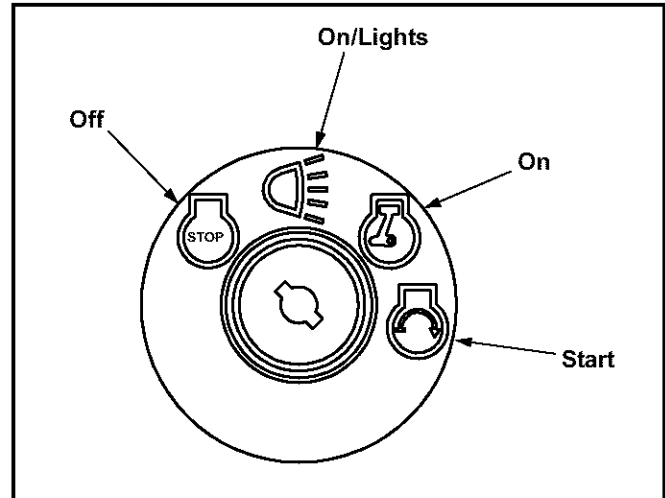

Figure 5

Refer to **Starting The Engine** on page 13 of this manual for detailed starting instructions

The ignition switch is also used to operate the tractor's headlights. Refer to **Operating The Headlights** on page 16 of this manual for detailed instructions.

Drive Pedal

The drive pedal is located below the brake pedal on the right front side of the tractor along the running board. Depress the upper portion of the drive pedal forward to cause the tractor to travel forward. Depress the lower portion of the drive pedal with the ball of your right foot (NOT your heel) to cause the tractor to travel in reverse. Ground speed is also controlled with the drive pedal. The further forward or rearward that the pedal is pivoted, the faster the tractor will travel. The pedal will return to its original position when it's not depressed.

IMPORTANT: Always set the parking brake when leaving the tractor unattended.

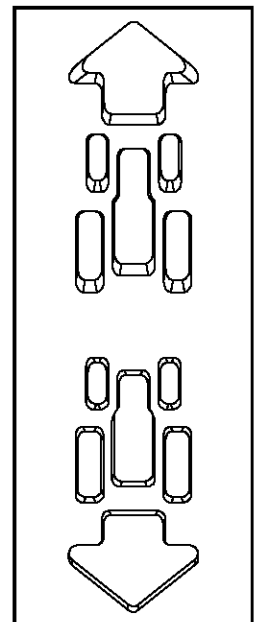

Hour Meter

Located in the center of the tractor's console, the hour meter operates whenever the engine is running and records the actual hours of tractor operation. See Figure 6.

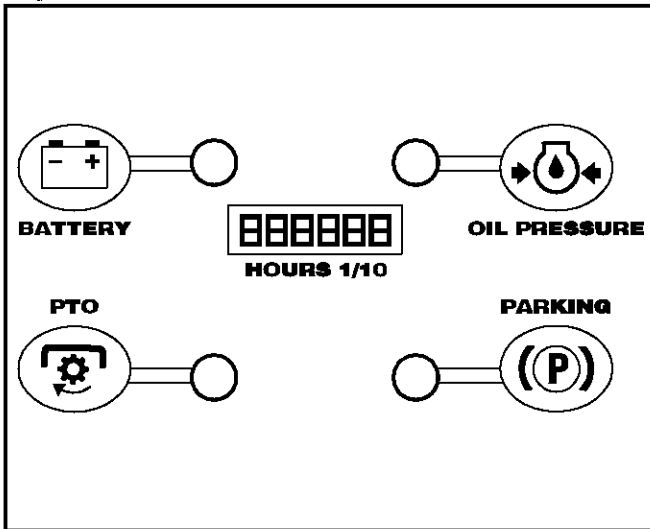

Figure 6

System Indicator Lights

Your tractor is equipped with four indicator lights in the center of its dash panel. If the Brake light or PTO light illuminates when attempting to start the unit, proceed as follows:

- Brake** — Engage the parking brake.
- PTO** — Move the PTO knob into the disengaged (OFF) position.

It is normal for the Oil light and the Battery light to illuminate while the engine is **cranking**, but if either illuminates while the **engine is running**, proceed as follows:

- Oil**— Stop the tractor immediately and check the crankcase oil level as instructed on page 19 of this manual. Add oil as required.
- Battery**— If this light illuminates while the engine is running, it indicates that the battery is in need of a charge OR that the engine's charging system is not generating sufficient amperage. Refer to **Battery** on page 25 of this manual for the proper battery charging procedure or have the engine's charging system checked by a *Cub Cadet* dealer.

Cup Holder

The tractor's cup holder is located on the fender to the right of the seat, just to the rear of the deck lift lever.

Electric PTO (Power Take-off) Knob

To engage the power to the cutting deck or other (separately available) attachments, pull outward on the PTO knob. Push the PTO knob inward to disengage the power to the cutting deck.

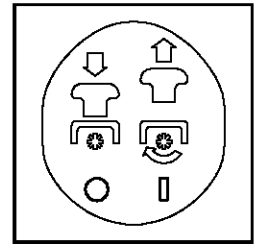

NOTE: The PTO knob **must** be in the disengaged (OFF) position when starting the engine, when traveling in reverse and if the operator leaves the seat.

Cruise Control Lever

The cruise control lever is located on the tractor dash panel, below the steering wheel.

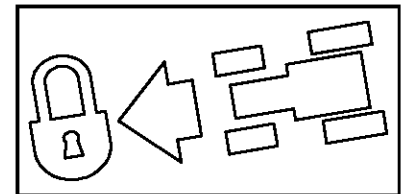

Push the cruise control lever downward while traveling forward at a desired speed. While holding the lever down, release pressure from the drive pedal.

This will engage the cruise control and allow the tractor to remain at that speed without applying pressure to the drive pedal. Depress the brake pedal or the drive pedal to deactivate cruise control. Refer to page 14 for detailed instructions regarding the cruise control feature.

NOTE: Cruise control can **NOT** be engaged at the tractor's fastest ground speed. If the operator should attempt to do so, the tractor will automatically decelerate to the fastest optimal mowing ground speed.

Parking Brake Lever

To set the parking brake, fully depress the brake pedal and push the parking brake lever down. Hold the lever down while taking your foot off the brake pedal. Both the parking lever and the brake pedal will then stay depressed. To release the parking brake, depress the brake pedal slightly. The parking brake lever will then return to its original position.

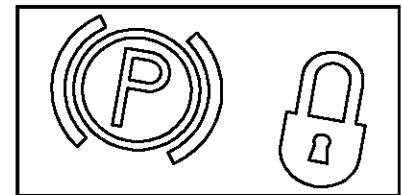

NOTE: The parking brake must be set if the operator leaves the seat with the engine running or the engine will automatically shut off.

IMPORTANT: Always set the parking brake when leaving the tractor unattended.

Seat Adjustment Lever

To adjust the seat forward or backward, slide the seat adjustment lever to the left and reposition the seat to the desired position. Once a comfortable position is found, release the seat adjustment lever to lock the seat in place. Refer to **Seat Adjustment** on page 17 of this manual for more detailed instructions.

Deck Lift Lever

Found on your tractor's right fender, the deck lift lever is used to change the height of the cutting deck. To use, move the lever to the left, then place in the notch best suited for your application.

SECTION 5: OPERATING YOUR LAWN TRACTOR



WARNING

AVOID SERIOUS INJURY OR DEATH

- GO UP AND DOWN SLOPES, NOT ACROSS.
- AVOID SUDDEN TURNS.
- DO NOT OPERATE THE UNIT WHERE IT COULD SLIP OR TIP.
- IF MACHINE STOPS GOING UPHILL, STOP BLADE(S) AND BACK DOWNHILL SLOWLY.
- DO NOT MOW WHEN CHILDREN OR OTHERS ARE AROUND.
- NEVER CARRY CHILDREN, EVEN WITH BLADES OFF.
- LOOK DOWN AND BEHIND BEFORE AND WHILE BACKING.
- KEEP SAFETY DEVICES (GUARDS, SHIELDS, AND SWITCHES) IN PLACE AND WORKING.
- REMOVE OBJECTS THAT COULD BE THROWN BY THE BLADE(S).
- KNOW LOCATION AND FUNCTION OF ALL CONTROLS.
- BE SURE BLADE(S) AND ENGINE ARE STOPPED BEFORE PLACING HANDS OR FEET NEAR BLADE(S).
- BEFORE LEAVING OPERATOR'S POSITION, DISENGAGE BLADE(S), ENGAGE BRAKE LOCK, SHUT ENGINE OFF AND REMOVE KEY.

READ OPERATOR'S MANUAL



WARNING: Read, understand, and follow all instructions and warnings on the machine and in this manual before operating.

Safety Interlock Switches

This tractor is equipped with a safety interlock system for the protection of the operator. If the interlock system should ever malfunction, do not operate the tractor. Contact a *Cub Cadet* dealer. The safety interlock system prevents the engine from cranking or starting unless the parking brake is engaged, and the PTO knob is in the disengaged (OFF) position.

- The engine will automatically shut off if the operator leaves the seat before engaging the parking brake.
- The engine will automatically shut off if the operator leaves the tractor's seat with the PTO knob in the engaged (ON) position, regardless of whether the parking brake is engaged.
- The electric PTO clutch will automatically shut off if the PTO knob is moved into the engaged (ON) position with the drive pedal in position for reverse travel.



WARNING: Do not operate the tractor if the interlock system is malfunctioning. This system was designed for your safety and protection.

Setting the Gauge Wheels

Select the height position of the cutting deck by placing the deck lift lever in any of the six different cutting height notches on the right fender.

To adjust the deck wheels so that they are between ¼-inch and ½-inch above the ground as follows.



WARNING: Keep hands and feet away from the discharge opening of the cutting deck.

NOTE: *The deck wheels are an anti-scalp feature of the deck and are not designed to support the weight of the cutting deck.*

Place the tractor on a firm and level surface, preferably pavement, refer to Figure 7, and proceed as follows:

- Place the tractor's deck lift handle in the normally desired mowing height setting, then check the gauge wheels for contact or excessive clearance with the surface below.
- If the wheels contact the surface adjust as follows:
 - a. Raise the deck lift handle to its highest setting.
 - b. Remove the rear gauge wheels by removing the lock nuts and shoulder screws that secure them to the deck.
 - c. Remove the lock nuts and shoulder screws, that secure the front gauge wheels to the deck.
 - d. Place the deck lift handle in the desired mowing height setting.
 - e. Insert the shoulder screw with the rear gauge wheel into the index hole that leaves approximately 1/2" between the bottom of the wheel and the pavement.
 - f. Note the position of the index hole used; then install the other rear gauge wheel and the front ball wheels into the corresponding index hole of the other gauge wheel brackets.

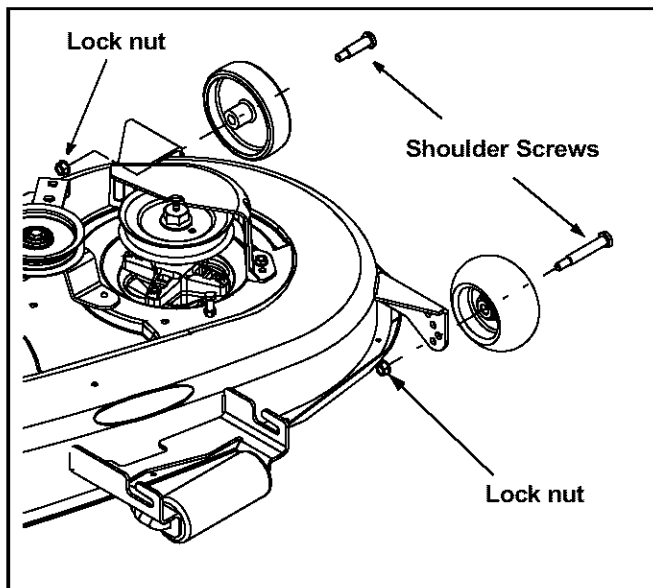

Figure 7

- If the gauge wheels have excessive clearance with the surface below, lower the wheels to the index hole that provides the approximate 1/2" clearance as described above.

Refer to **Leveling the Deck** on page 17 of this manual for more detailed instructions regarding various deck adjustments.

Starting the Engine



WARNING: Do not operate the tractor if the interlock system is malfunctioning. This system was designed for your safety and protection.

NOTE: Refer to the **TRACTOR SET-UP** on page 8 of this manual for Gasoline and Oil fill-up instructions.

- Insert the tractor key into the ignition switch.
- Place the PTO knob in the disengaged (OFF) position.
- Engage the tractor's parking brake.
- Move the throttle control to midway between its SLOW and FAST positions.
- Pull the choke control outward.
- Turn the ignition key clockwise to the START position. After the engine starts, release the key. It will return to the ON position.

IMPORTANT: Do NOT hold the key in the START position for longer than five seconds at a time. Doing so may cause damage to your engine's electric starter. If the engine does not start right away, wait 15 seconds and try again.

- After the engine starts, deactivate the choke control.

- After the engine starts, allow the engine to warm up by running it for 3 to 5 minutes at mid throttle before putting the equipment under load.

NOTE: Do NOT leave the choke control on while operating the tractor. Doing so will result in a "rich" fuel mixture and cause the engine to run poorly.

Stopping the Engine



WARNING: If you strike a foreign object, stop the engine, disconnect the spark plug wire(s) and ground against the engine. Thoroughly inspect the machine for any damage. Repair the damage before restarting and operating

- If the blades are engaged, place the PTO knob in the disengaged (OFF) position.
- Move the throttle control to the SLOW position and allow the engine to idle for about one minute.
- Turn the ignition key counterclockwise to the STOP position.
- Remove the key from the ignition switch to prevent unintended starting.

Engaging the Parking Brake

To engage the parking brake:

- Fully depress the brake pedal and hold it there while gently pushing the parking brake lever downward.
- Hold the parking brake lever down while removing your foot from the brake pedal.
- Once engaged, the parking brake lever and the brake pedal will lock in the "down" position.

To disengage the parking brake:

- Slightly depress the brake pedal.

NOTE: The parking brake must be engaged if the operator leaves the seat with the engine running or the engine will automatically shut off.

Driving The Tractor



WARNING: Avoid sudden starts, excessive speed and sudden stops.



WARNING: Do not leave the seat of the tractor without first placing the PTO knob in the disengaged (OFF) position, depressing the brake pedal and engaging the parking brake. If leaving the tractor unattended, also turn the ignition key off and remove the key.

- Briefly depress the brake pedal to release the parking brake. Move the throttle lever into the FAST (rabbit) position.
- To travel FORWARD, slowly depress the upper portion of the drive pedal forward until the desired speed is achieved. See Figure 8.

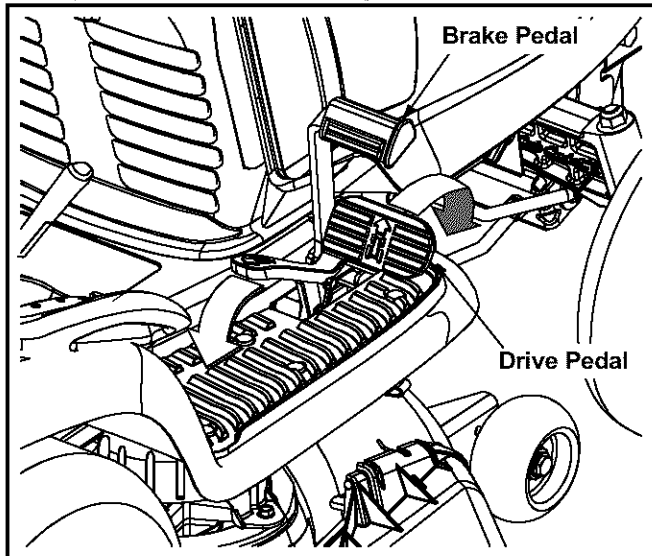

Figure 8

- To travel in REVERSE, check that the area behind is clear then slowly depress the lower portion of the drive pedal with the ball of your foot (NOT your heel) until the desired speed is achieved. See Figure 8.

IMPORTANT: Do NOT attempt to change the direction of travel when the tractor is in motion. Always bring the tractor to a **complete** stop before pivoting the drive pedal from forward to reverse or vice versa.

Driving On Slopes

Refer to the **SLOPE GAUGE** on page 7 to help determine slopes where you may operate the tractor safely.



WARNING: Do not mow on inclines with a slope in excess of 15 degrees (a rise of approximately 2-1/2 feet every 10 feet). The tractor could overturn and cause serious injury.

- Mow up and down slopes, NEVER across.
- Exercise extreme caution when changing direction on slopes.
- Watch for holes, ruts, bumps, rocks, or other hidden objects. Uneven terrain could overturn the machine. Tall grass can hide obstacles.
- Avoid turns when driving on a slope. If a turn must be made, turn down the slope. Turning up a slope greatly increases the chance of a roll over.
- Avoid stopping when driving up a slope. If it is necessary to stop while driving up a slope, start up smoothly and carefully to reduce the possibility of flipping the tractor over backward.

Setting The Cruise Control

NOTE: The cruise control feature should only be utilized while traveling in the forward direction.

- Slowly depress the upper portion of the drive pedal until the desired speed is achieved.
- Lightly depress the cruise control lever.
- While continuing to hold the cruise lever down, lift your foot from the drive pedal (you should feel the cruise latch engage).
- Once engaged, the cruise control lever and the drive pedal will lock in the "down" position, and the tractor will maintain the same forward speed.

NOTE: Cruise control cannot be engaged at the tractor's fastest ground speed. If the operator should attempt to do so, the tractor will automatically decelerate to the fastest optimal mowing ground speed.

Disengage the cruise control using one of the following methods:

- Depress the brake pedal to disengage the cruise control and stop the tractor.
- Lightly depress the drive pedal.

To change the direction of travel to reverse when operating with cruise control, depress the brake pedal to disengage the cruise control and bring the tractor to a complete stop. Then slowly depress the lower portion of the drive pedal with the ball of your foot to travel in reverse.

Using the Deck Lift Lever

To raise the cutting deck, move the deck lift lever to the left, then place it in the notch best suited for your application. Refer to **Setting The Gauge Wheels** earlier in this section.

Operating The Headlights

To turn the tractor's headlights on:

- Start the engine following the instructions earlier in this section.
- Turn the key one notch counterclockwise into the On/Lights position of the ignition switch. Refer to Figure 5.

To turn the tractor's headlights off:

- Turn the key either into the On position (to leave the engine running) or the Off position (to shut the engine off). Refer to Figure 5.

NOTE: Never move the key into the Start position while the engine is running. Doing so may cause damage to your engine's electric starter.

Moving The Tractor Manually

Your tractor's transmission is equipped with a hydrostatic relief valve for occasions when it is necessary to move the tractor manually. Opening this valve permits the fluid in the transmission to bypass its normal route, allowing the rear tires to "freewheel." To engage the hydrostatic relief valve, proceed as follows:

- Locate the hydrostatic bypass rod in the rear of the tractor. See Figure 9.

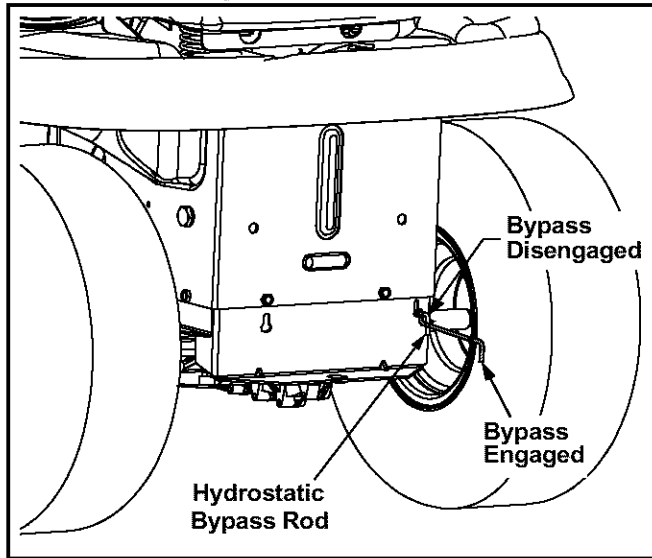

Figure 9

- Pull the hydrostatic bypass rod outward, then down, to lock it in place.

NOTE: The transmission will NOT engage when the hydrostatic bypass rod is pulled out. Return the rod to its normal position prior to operating the tractor.

IMPORTANT: Never attempt to move the tractor manually without first engaging the hydrostatic relief valve. Doing so will result in serious damage to the tractor's transmission.

Engaging the PTO

Engaging the PTO transfers power to the cutting deck or other (separately available) attachments. To engage the PTO, proceed as follows:

- Move the throttle control lever to between the MID throttle and FAST (rabbit) positions.
- Pull the PTO knob outward into the engaged (ON) position. See Figure 10.
- Keep the throttle lever in the FAST (rabbit) position for the most efficient use of the cutting deck or other (separately available) attachments

IMPORTANT: The electric PTO clutch will automatically shut off if the PTO is engaged with the drive pedal in position for reverse travel. Refer to **Safety Interlock Switches** on page 12.

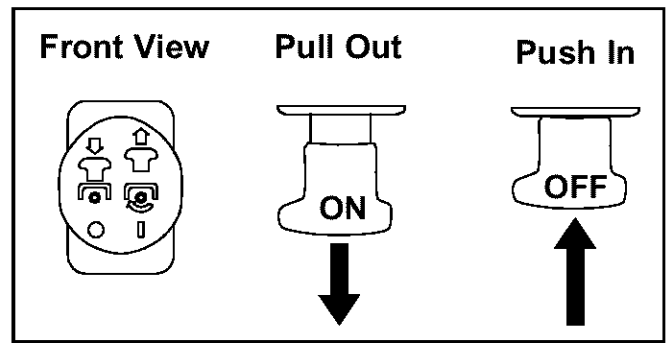

Figure 10

Mowing



WARNING: To help avoid blade contact or a thrown object injury, keep bystanders, helpers, children and pets at least 75 feet from the machine while it is in operation. Stop machine if anyone enters the area.

This tractor is equipped with one of *Cub Cadet's* quality cutting decks. The following information will be helpful when using the cutting deck with your tractor.



WARNING: Plan your mowing pattern to avoid discharge of materials toward roads, sidewalks, bystanders and the like. Also, avoid discharging material against a wall or obstruction which may cause discharged material to ricochet back toward the operator.

- Do not mow at high ground speed, especially if a mulch kit or grass collector is installed.
- For best results it is recommended that the first two laps be cut with the discharge thrown towards the center. After the first two laps, reverse the direction to throw the discharge to the outside for the balance of cutting. This will give a better appearance to the lawn.
- Do not cut the grass too short. Short grass invites weed growth and yellows quickly in dry weather.
- Mowing should always be done with the engine at full throttle.
- Under heavier conditions it may be necessary to go back over the cut area a second time to get a clean cut.
- Do NOT attempt to mow heavy brush and weeds and extremely tall grass. Your tractor is designed to mow lawns, NOT clear brush.
- Keep the blades sharp and replace the blades when worn. Refer to **Cutting Blades** on page 24 of this manual for proper blade sharpening instructions.

Mulching

Model 1525 & 1527 lawn tractors come equipped with a mulch kit which incorporates special blades, already standard on your tractor, in a process of recirculating grass clippings repeatedly beneath the cutting deck. The ultra-fine clippings are then blown back into the lawn where they act as a natural fertilizer. Observe the following points for the best results when mulching.

- Never attempt to mulch if the lawn is damp. Wet grass tends to stick to the underside of the cutting deck preventing proper mulching of the clippings.
- Do NOT attempt to mulch more than 1/3 the total height of the grass or approximately 1-1/2 inches. Doing so will cause the clippings to clump up beneath the deck and not be mulched effectively.
- Maintain a slow ground speed to allow the grass clippings more time to effectively be mulched.
- Always position the throttle control lever in the FAST (rabbit) position and allow it to remain there while mowing. Failing to keep the engine at full throttle places strain on the tractor's engine and does not allow the blades to properly mulch grass.

NOTE: *It is not necessary to remove the discharge chute to operate the mower with the mulch kit installed.*

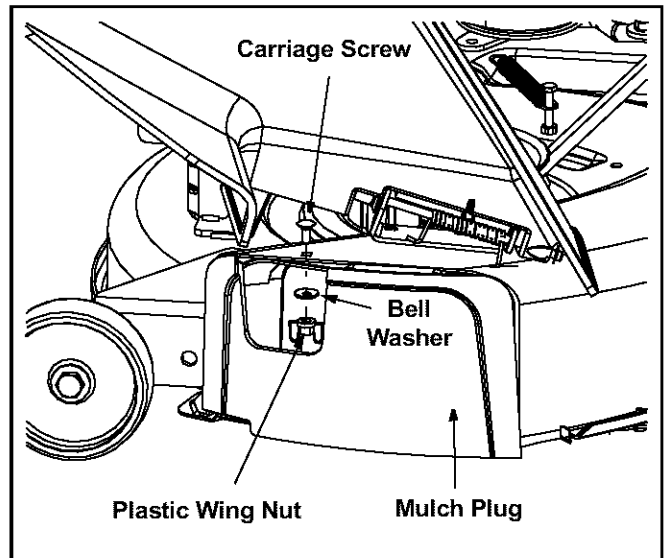

Figure 11

To operate the cutting deck without mulching, simply remove the mulch plug by unthreading the plastic wing nut which fastens it to the cutting deck. This will allow the clippings to discharge out the side. See Figure 11

SECTION 6: MAKING ADJUSTMENTS



WARNING: Never attempt to make any adjustments while the engine is running, except where specified in the operator's manual.



WARNING: Disconnect the spark plug wire(s) and ground against the engine before performing any adjustments, repairs or maintenance.

Carburetor

The carburetor is a main component of the emission control system and should be adjusted or serviced only by a qualified mechanic.

The carburetor's main fuel jet is fixed. The low idle fuel adjusting needle has only minimal adjustment and normally does not need adjustment.

If the engine is hard to start, runs roughly, or stalls at low idle speed, contact your Cub Cadet dealer for carburetor service.

Leveling the Deck

NOTE: Check the tractor's tire pressure before performing any deck leveling adjustments. Refer to **Tires** on page 24 for information regarding tire pressure.

Front To Rear

The front of the cutting deck is supported by a stabilizer bar that can be adjusted to level the deck from front to rear. The front of the deck should be between 1/4-inch and 3/8-inch lower than the rear of the deck. Adjust if necessary as follows:

- With the tractor parked on a firm, level surface, place the deck lift lever in the top notch (highest position) and rotate the blade nearest the discharge chute so that it is parallel with the tractor.
- Measure the distance from the front of the blade tip to the ground and the distance from the rear of the blade tip to the ground.
- The first measurement taken should be between 1/4" and 3/8" less than the second measurement.
- Determine the approximate distance necessary for proper adjustment and proceed, if necessary, to the next step.
- Loosen the two jam nuts on the rear side of the deck stabilizer bracket. See Figure 12.

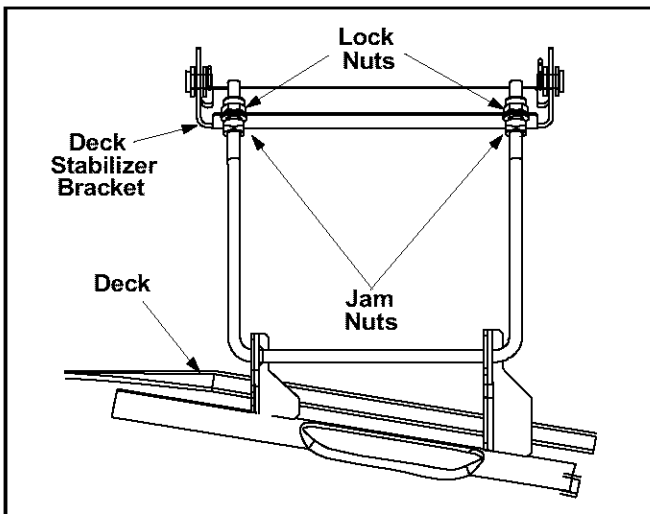

Figure 12

- Locate the two lock nuts on the opposite side of the stabilizer bracket. See Figure 12. Tighten the lock nuts to raise the front of the deck; loosen the lock nuts to lower the front of the deck.
- Retighten the two jam nuts loosened earlier when proper adjustment is achieved.

Side to Side

If the cutting deck appears to be mowing unevenly, a side to side adjustment can be performed. Adjust if necessary as follows:

- With the tractor parked on a firm, level surface, place the deck lift lever in the top notch (highest position) and rotate both blades so that they are perpendicular with the tractor.
- Measure the distance from the outside of the left blade tip to the ground and the distance from the outside of the right blade tip to the ground. Both measurements taken should be equal. If they're not, proceed to the next step.
- Loosen, but do NOT remove, the hex cap screw on the left deck hanger bracket. See Figure 13
- Balance the deck by using a wrench to turn the adjustment gear (found immediately behind the hex cap screw just loosened) clockwise/up or counterclockwise/down.

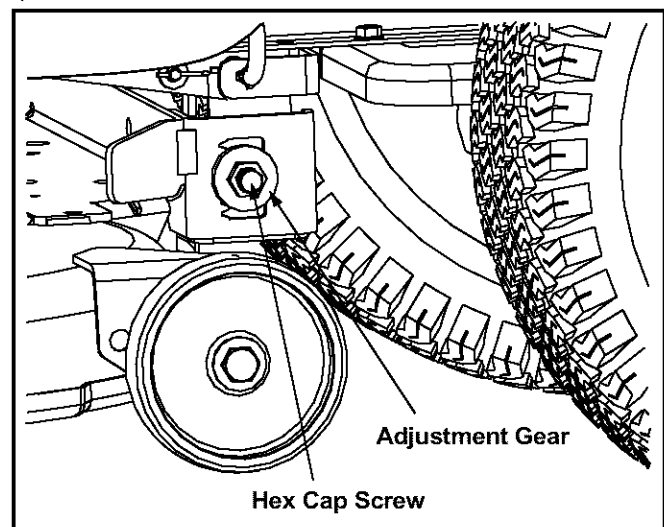

Figure 13

- The deck is properly balanced when both blade tip measurements taken earlier are equal.
- Retighten the hex cap screw on the left deck hanger bracket when proper adjustment is achieved.

Parking Brake Adjustment



WARNING: Never attempt to adjust the brakes while the engine is running. Always disengage PTO, stop engine and remove key to prevent unintended starting.

If the tractor does not come to a complete stop when the brake pedal is completely depressed, or if the tractor's rear wheels can roll with the parking brake applied, the brake is in need of adjustment. The brake disc can be found on the right side of the transmission in the rear of the tractor. Adjust if necessary as follows.

- Looking at the transmission from the right side of the tractor, locate the compression spring and brake disc. See Figure 14.

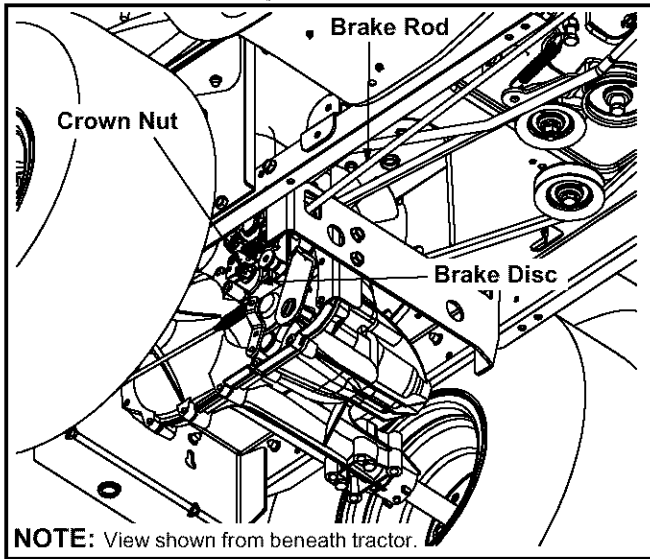

NOTE: View shown from beneath tractor.

Figure 14

- Carefully remove the cotter pin from the crown nut on the right side of the brake assembly.
- Using a feeler gauge, check the gap between the brake disc and the brake puck. Proper gap is .011".
- Tighten the crown nut until the proper gap is achieved.
- Insert a replacement cotter pin (part # 714-0111) into the crown nut.

Steering Adjustment

If the tractor turns tighter in one direction than the other, or if the ball joints are being replaced due to damage or wear, the steering drag links may need to be adjusted.

Adjust the drag links so that equal lengths are threaded into the ball joint on the left side and the ball joint on the right side:

- Loosen the jam nut found on the drag link at the rear of the ball joint. See Figure 15.
- Remove the hex nut and lock washer on the top of ball joint. See Figure 15.
- Thread the ball joint toward the jam nut to shorten the drag link. Thread the ball joint away from the jam nut to lengthen the drag link.
- Replace hex nut and lock washer and retighten the jam nut after proper adjustment is achieved.

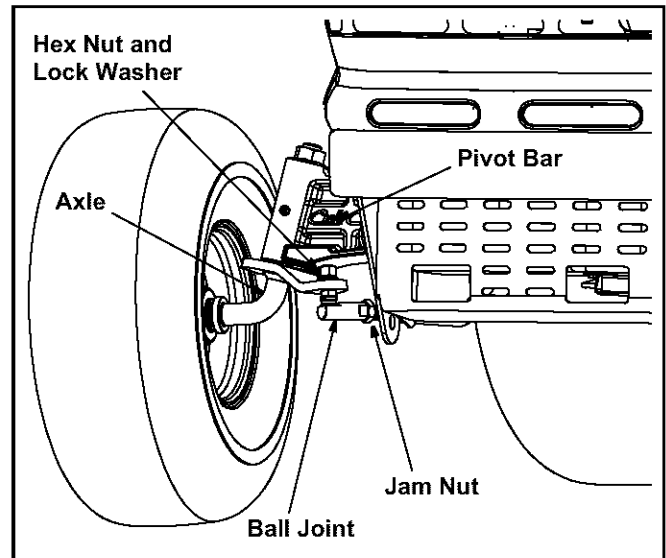

Figure 15

NOTE: Threading the ball joints too far onto the drag links will cause the front tires to "toe-in" too far. Proper toe-in is between 1/16" and 5/16".

Front tire toe-in can be measured as follows:

- Place the steering wheel in position for straight ahead travel.
- In front of the axle, measure the distance horizontally from the inside of the left rim to the inside of the right rim. Note the distance.
- Behind the axle, measure the distance horizontally from the inside of the left rim to the inside of the right rim. Note the distance.
- The measurement taken in front of the axle should be between 1/16" and 5/16" less than the measurement taken behind the axle.
- Adjust if necessary.

Seat Adjustment



WARNING: Before operating this machine, make sure the seat is engaged in the seat stop, stand behind the machine and pull back on seat until fully engaged into stop.

To adjust the position of the seat, move the seat adjustment lever (Refer to Figure 3 on Page 9) to the left and slide the seat forward or rearward. Make sure seat is locked into position before operating the tractor.

SECTION 7: MAINTAINING YOUR LAWN TRACTOR

NOTE: Refer to Maintenance Chart on page 29 for a reference of recommended maintenance intervals.



WARNING: Before performing any maintenance or repairs, disengage PTO, set parking brake, stop engine and remove key to prevent unintended starting.

Engine

Maintenance, repair, or replacement of the emission control devices and systems, which are being done at the customer's expense, may be performed by any engine repair establishment or individual. **Warranty repairs must be performed by your Cub Cadet Dealer.**

Engine Oil

The engine-crankcase is filled with 10W-30 ship-away oil at the factory. This oil may be used for the first 8 hours of engine operation at temperatures between 0°F and 90°F.

The engine oil must be drained and replaced with new oil after 8 hours of engine operation and every 100 hours thereafter. Refer to the Oil Viscosity Chart below to determine the proper oil type.

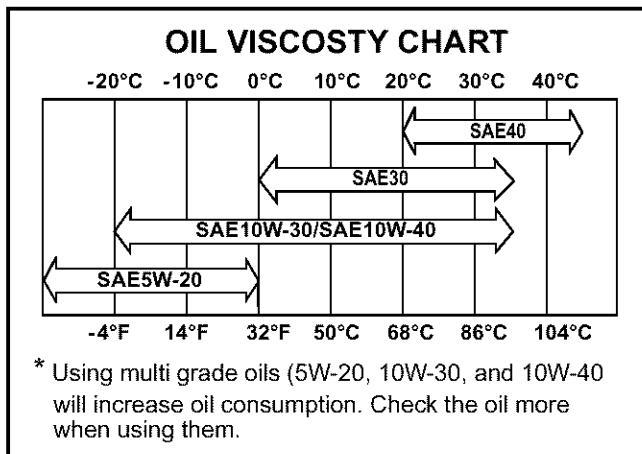

NOTE: To aid starting, the selection of crankcase oil should be based on the lowest anticipated temperatures prior to the next scheduled oil change.

Checking the Oil Level

It is important to check the oil level at least every four hours of operation. Regular checking during the first 8 hours of operation is especially important. Check the oil level **before each use** as follows:

- Allow the engine a few minutes to rest after operation. This will give the oil time to drain into the crankcase sump and result in a more accurate dipstick reading.

- Clean the area around the oil fill cap/dipstick to prevent debris from entering the crankcase. Refer to Figure 18.
- Remove the oil fill cap/dipstick by unthreading it (counterclockwise) and lifting it out of the oil fill tube.
- Wipe the dipstick clean before pushing it back into the oil fill tube. **Do NOT thread the cap back onto the fill tube.** Withdraw the dipstick to check the oil level. Refer to Figure 16.
- Always keep the oil level at or near the FULL mark on the dipstick. If the oil is low, add oil of the proper type up to the FULL mark. Always re-check the oil level with the dipstick before adding more oil.

IMPORTANT: Never operate the engine with the oil level below the ADD mark or above the FULL mark on the dipstick.

- After checking the oil level (and adding oil, if necessary), reinstall the oil fill cap/dipstick by inserting it into the oil fill tube and threading (clockwise).

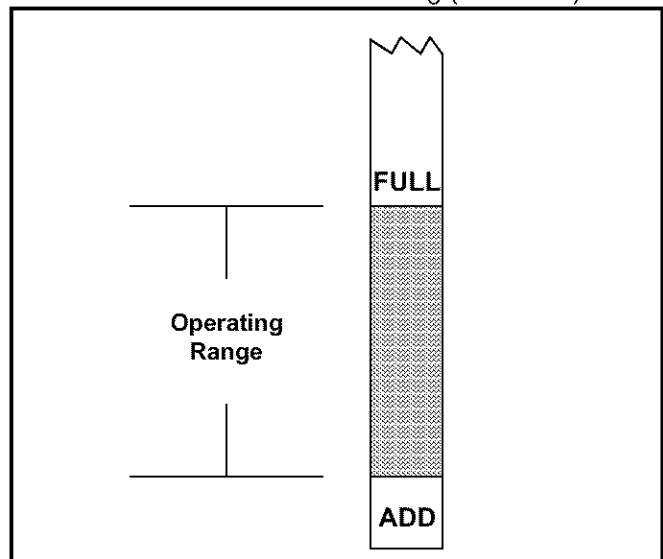

Figure 16

Adding Oil

If, after checking the oil level, you find the dipstick reads ADD, proceed as follows.

- Place the tractor on a level surface and engage the parking brake. Stop the tractor engine and remove the ignition key.
- Clean the area around the oil fill cap and fill tube to prevent debris from entering the crankcase.
- Remove the oil fill cap/dipstick from the oil fill tube and SLOWLY pour oil into the oil fill tube. Do NOT pour more than 6 oz. of oil at a time without first stopping and re-checking the oil level.

- Fill the crankcase until the oil level reaches the full (F) mark on the dipstick. Refer to Figure 16. Refer to the viscosity oil chart earlier in this section for information regarding the proper type of oil to add to the crankcase.

IMPORTANT: The oil capacity (with oil filter) is 1.8 U.S. quarts (57.6 oz.). Never overfill the engine crankcase.

IMPORTANT: The engine may overheat and/or damage may result if the oil level is below the ADD or over the FULL on the dipstick.

- Reinstall the oil fill cap/dipstick securely onto the oil fill tube.

IMPORTANT: The oil fill cap/dipstick **must be installed securely onto the tube at all times when the engine is operating**. Severe engine damage could result from failure to do so.

Changing the Engine Oil

The engine oil and oil filter should be changed after the first 8 hours of operation, and after every 100 hours of operation thereafter.



WARNING: If the engine has been recently run, the engine, muffler and surrounding metal surfaces will be hot and can cause burns to the skin. Allow the tractor to cool and use caution when removing

IMPORTANT: The oil filter should be changed at every oil change interval.

To complete an oil change, proceed as follows:

Removing the Left-hand Side Panel

- Engage the tractor's parking brake and raise the hood.
- Loosen, but do not remove, the rear wing nut and upper front wing nut. See Figure 17.

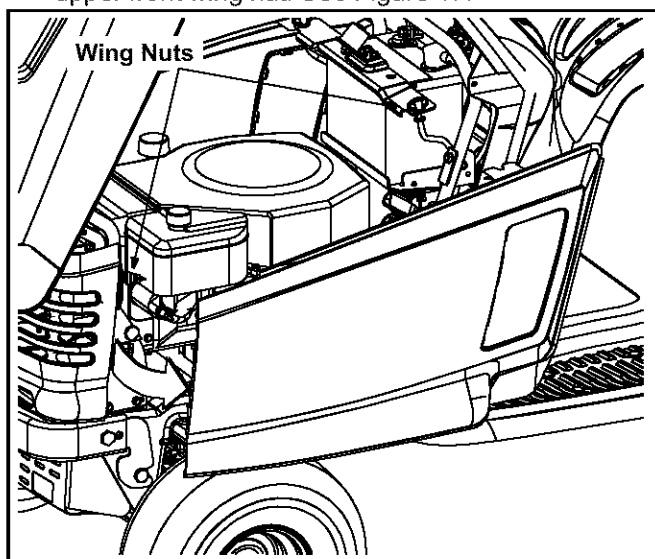

Figure 17

- Grasp the side panel just behind the grille and pull outward to release the side panel from the tapered bushings on the grille.
- Slide the side panel forward and out of the groove in the dash panel.

Draining the Oil

Run the engine for a few minutes to allow the oil in the crankcase to warm up. Warm oil will flow more freely and carry away more of the engine sediment which may have settled at the bottom of the crankcase. Use care to avoid burns from hot oil.

- Unscrew oil fill cap and remove dipstick from the oil fill tube
- Pop open the protective cap on the end of the oil drain valve to expose the drain port. See Figure 18.

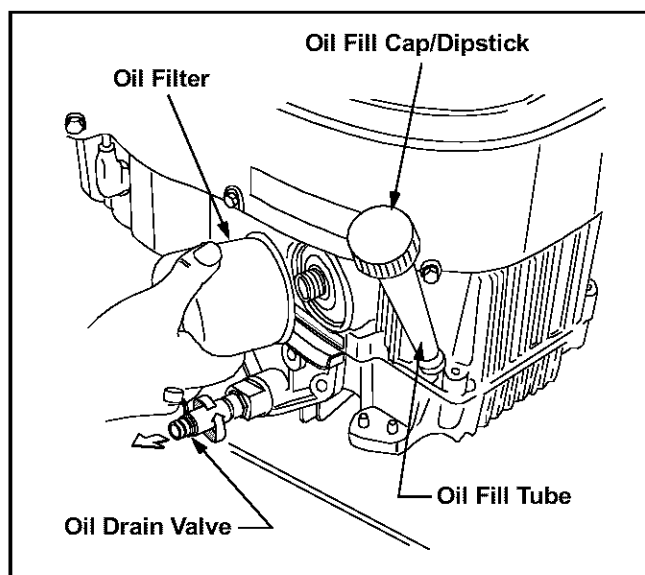

Figure 18

- Push the oil drain hose (packed with this manual) onto the oil drain port. Route the opposite end of the hose into an appropriate oil collection container with a capacity great enough to collect the used oil (approximately 1.8 quarts or 57.6 oz.).
- Push the oil drain valve in slightly, then rotate counterclockwise and pull outward to begin draining oil. See Figure 18.
- After the oil has finished draining, push the oil drain valve back in, rotate it clockwise to lock the valve closed. Re-cap the end of the oil drain valve to keep debris from entering the drain port.

IMPORTANT: Always change the oil filter when performing an oil change on your tractor's engine.

Changing the Oil Filter

After draining the oil, proceed as follows:

NOTE: Refer to the **Attachments & Accessories** table found on page 32 of this manual for the proper oil filter.

- Before removing the old oil filter, clean around its base to prevent debris from entering the crankcase.
- Grasp the oil filter and remove it from the engine by turning it counterclockwise. Use an oil filter wrench, if necessary.
- Place a new replacement filter in a shallow pan with the open end up and pour new oil of the proper type (see chart on page 19), in through the threaded center hole.

IMPORTANT: Stop pouring when the oil reaches the bottom of the threads and allow a minute or two for the oil to be absorbed by the filter material.

- Put a drop of oil on your fingertip and apply a light coating to the gasket of the new oil filter.
- Install the replacement oil filter on the engine by turning it clockwise until the rubber gasket contacts the mounting surface. Hand tighten the filter an additional **3/4 turn** after the gasket first makes contact.

Re-filling the Crankcase with Oil

IMPORTANT: The engine (with oil filter) has a capacity of 1.8 quarts (57.6 oz.). Do NOT overfill. Always check the level on the dipstick as instructed on page 19 before adding more oil.

NOTE: For the proper oil type, refer to the chart on page 19 of this manual.

- Clean the area around the oil fill tube to prevent debris from entering the crankcase.
- **Slowly** pour oil into the fill tube. Fill the crankcase until the oil level reaches the full (F) mark on the dipstick (Refer to Figure 16).
- Reinstall the oil fill cap/dipstick securely into the oil fill tube.

IMPORTANT: The oil fill cap/dipstick **must be installed securely onto the tube at all times when the engine is operating**. Severe engine damage could result from a failure to do so.

- Start the tractor engine and allow it to run for about three minutes, then stop the engine and remove the ignition key.
- Check the oil level and add oil if necessary.
- Examine the area around the oil filter the oil drain valve for leaks before operating the tractor.

IMPORTANT: If leaks are present, have your engine serviced by your *Cub Cadet* dealer before operating the tractor.

Air Filter

The engine is equipped with a replaceable foam pre-cleaner and paper air cleaner element. See Figure 19. Always examine the air cleaner **before starting the engine**. Check for a buildup of dirt and debris around

the air cleaner system. Keep this area clean. Also check for loose or damaged components. Replace all damaged air cleaner components.

NOTE: Starting the tractor with loose or damaged air cleaner components could allow unfiltered air into the engine causing premature wear and failure.

Air Filter Removal

Model 1525 ONLY

- Press down and hold the two latches on the top of the air cleaner cover while rotating the top of the cover away from the air cleaner base. Refer to Figure 19.
- Remove the paper element and pre-cleaner from the air cleaner cover. See Figure 19.

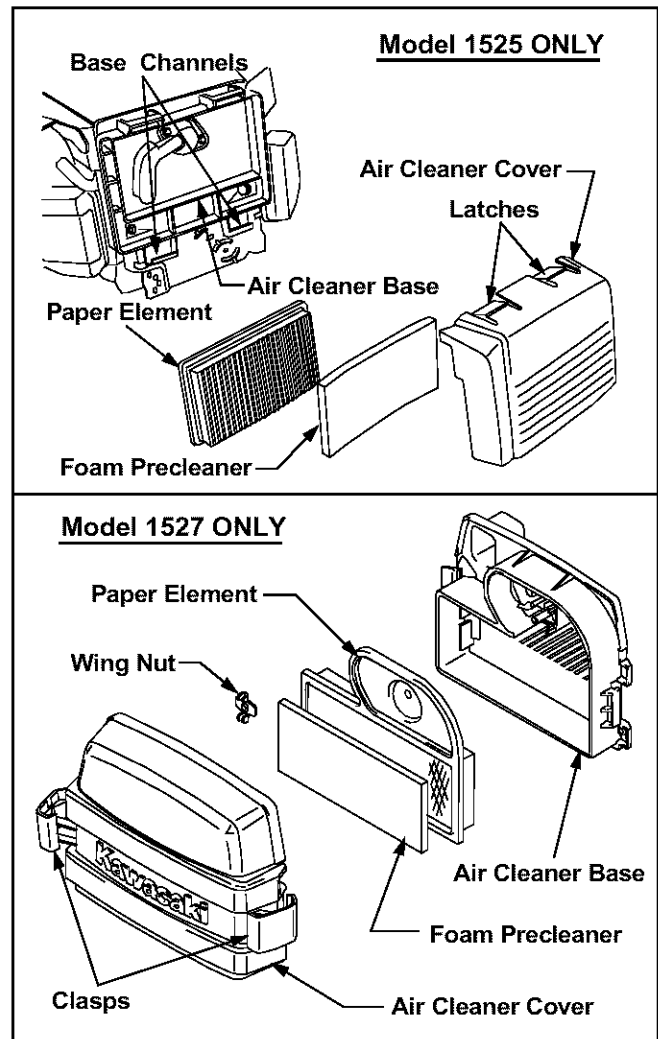

Figure 19

Model 1527 ONLY

- Pull the two clasps away from the sides of the air cleaner cover; then unhook the clasps from the tabs on the air cleaner base. See Figure 19.
- Unthread the wing nut to remove the paper element and pre-cleaner from the air cleaner base.

Service the FoamPrecleaner

- Clean the precleaner after every **25 hours** of operation. More often if operating under extremely dusty or dirty conditions.
- Wash the precleaner in detergent and water.
- Rinse the precleaner thoroughly until all traces of detergent are eliminated. Squeeze out excess water — **DO NOT WRING**. Allow the foam element to air dry.

Service Paper Element

NOTE: Refer to the **Attachments & Accessories** table found on page 32 of this manual for the proper air filter.

The paper element should be replaced at least every **100 hours** of operation. Replace more frequently if the tractor is operated under extremely dusty conditions.

IMPORTANT: Do **not** wash the paper element or use pressurized air, as this will damage the element.

Examine the element and discard if dirt and/or damage is present.

NOTE: Handle new elements carefully; do not use if the sealing surfaces are damaged.

- Clean any dirt or debris from the air cleaner base and cover.
- Check the air cleaner base. Make sure it is secured and not damaged. Also check the air cleaner cover for damage or improper fit. Replace all damaged air cleaner components.

Air Filter Installation

Model 1525 ONLY

- Carefully install the paper element and foam precleaner in the air cleaner cover.
- Insert the two hooks on the bottom of the cover into the two channels of the air cleaner base. Refer to Figure 19.
- Rotate the top of the cover upward and guide the cover latches through the top slots in the base. Push the top of the cover rearward until the latches snap upward and lock the cover in place.

IMPORTANT: Make certain the cover latches are captured in the base slots. Failure to do so may allow the cover to loosen and allow unfiltered air to be ingested by the engine, resulting in premature wear and failure of the engine.

Model 1527 ONLY

- Carefully Install the element (with precleaner) on the base and secure it with the wing nut.
- Position the air cleaner cover over the base and hook the clasps behind the tabs on the base. Refer to Figure 19.
- Push the clasps inward toward the cover to lock them in the closed position.

Spark Plug

Every **100 hours** of operation, remove the spark plug, check its condition, and reset the gap or replace with a new plug as necessary.

NOTE: Refer to the **Attachments & Accessories** table found on page 32 of this manual for the proper spark plug type.

- Lift the tractor's hood and locate the spark plug wires on each side of the engine.
- Carefully pull the spark plug wire boots off of the spark plugs.
- Before removing the spark plug, clean the area around the base of the plug to keep dirt and debris out of the engine.
- Using a spark plug socket, remove the spark plugs and check their condition.
- Replace a plug if worn or damaged. Clean minor carbon deposits from the electrode using a soft wire brush. Check and re-set the gap as instructed in the following steps.

NOTE: Do not clean the spark plug in a machine using abrasive grit. Some grit could remain in the spark plug and enter the engine causing extensive wear and damage.

- Check the gap using a feeler gauge and adjust, if necessary, by carefully bending the ground electrode. See Figure 20. Set the spark plug gap to 0.75 mm (0.030 in.).

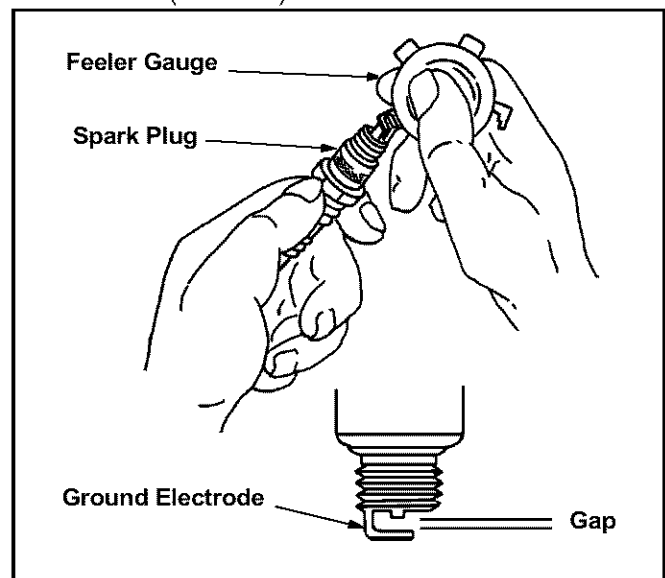

Figure 20

- Reinstall the spark plugs into the cylinder heads. Torque the spark plug to **22 N·m (16 ft. lb.)**.
- Place the spark plug wire boots over the spark plugs and press until you feel the plug wire connectors snap over the terminal of the spark plugs.

Fuel Filter and Pump



WARNING: Do not replace the fuel filter or pump when engine is hot.

The engine is equipped with an inline fuel filter and fuel pump located on the right side of the engine.

Visually inspect the filter periodically for a build-up of residue inside the filter body, and for a dirty element which can be indicated by discoloration. Replace the fuel filter when dirty.

The fuel pump can not be disassembled. If the fuel pump fails, replace it with a new one.

NOTE: If necessary, remove the tractor's right-hand side panel as instructed on page 20 before changing the engine's fuel filter.

Cleaning the Engine And Deck

Any fuel or oil spilled on the machine should be wiped off promptly.

Do NOT allow debris to accumulate around the engine air intake screen and cooling fins. Every 100 hours of operation, check and clean the cooling fins and inside of engine shrouds to remove grass, chaff or dirt clogging the cooling system. Remove the fan housing and intake screen to clean the engine.

Do NOT allow debris to accumulate around or on any other part of the machine, especially the belts and pulleys.

IMPORTANT: The use of a pressure washer or garden hose to clean your tractor is NOT recommended. It may cause damage to electrical components, spindles, pulleys, bearings or the engine. The use of water will result in a shortened life of the tractor and reduce its serviceability.

Lubrication



WARNING: Before lubricating, repairing, or inspecting, always disengage PTO, set parking brake, stop engine and remove key to prevent unintended starting.

Engine

Refer to **Engine** on page 19 for instruction regarding all engine-related lubrication.

Deck Spindles

Grease fittings can be found on the top of each deck spindle shaft. See Figure 21. Lubricate with 251H EP grease, or an equivalent No. 2 multi-purpose lithium grease, after every 10 hours of operation. Using a grease gun, apply two strokes (minimum) or sufficient grease to flush old grease and dirt out of the spindle shaft.

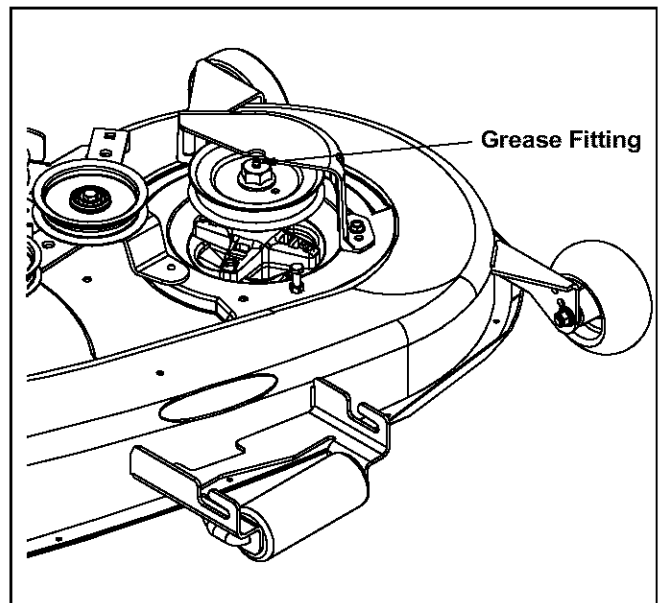

Figure 21

Pivot Points & Linkage

Lubricate all the pivot points on the drive system, parking brake and lift linkage at least once a season with light oil.

Deck Wheels

Each of the tractor deck's front gauge wheels is equipped with a grease fitting. Lubricate with a grease gun after every 25 hours of tractor operation.

Front Wheels

Each of the front wheel axles and rims is equipped with a grease fitting. See Figure 22. Lubricate with a grease gun after every 25 hours of tractor operation.

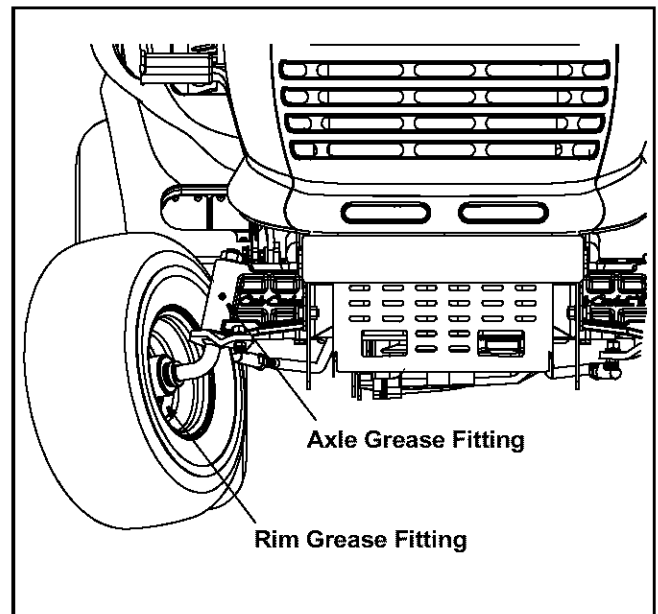

Figure 22

SECTION 8: SERVICE

Head Lamp



WARNING: If the engine has been recently run, the engine, muffler and surrounding metal surfaces will be hot and can cause burns to the skin. Allow the tractor to cool and use caution when changing the lamp bulbs.

Replace headlight bulbs as follows:

NOTE: Pay attention to which wire connects to each lamp terminal before disconnecting.

- Unplug the wire harness leads from the lamp socket terminals. See Figure 23.
- To remove the bulb & socket from the reflector housing, align the tab of the socket with the notch of the reflector, then push the socket inward and turn as follows to unlock:
Left lamp — 1/4 turn counterclockwise.
Right lamp — 1/4 turn clockwise.
- With the terminals pointing upward, align the tab of the replacement bulb & socket with the notch of the reflector. Push then socket inward and turn as follows to lock:
Left lamp — 1/4 turn clockwise.
Right lamp — 1/4 turn counterclockwise.
- Re-connect the wire harness leads to the appropriate socket terminals.

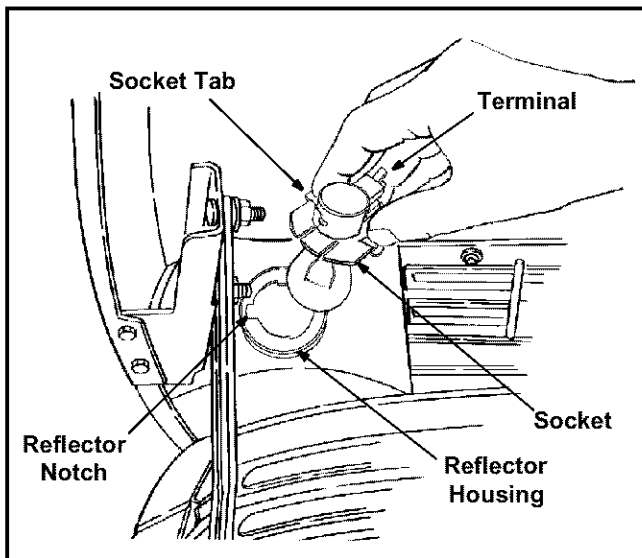

Figure 23

Tires



WARNING: Never exceed the maximum inflation pressure shown on the sidewall of the tire.

The recommended operating tire pressure is: approximately 10 psi for the rear tires and approximately 14 psi for the front tires.

Refer to the tire sidewall for exact tire manufacturer's recommended or maximum psi. Do not overinflate. Uneven tire pressure could cause the cutting deck to mow unevenly.

Cutting Blades



WARNING: Be sure to shut the engine off, remove ignition key, disconnect the spark plug wire(s) and ground against the engine to prevent unintended starting before removing the cutting blade(s) for sharpening or replacement. Protect your hands by using heavy gloves or a rag to grasp the cutting blade.



WARNING: Periodically inspect the spindle bolts and housings for cracks or damage, especially if you strike a foreign object. Replace immediately if damaged.

The blades may be removed as follows.

- Remove the deck from beneath the tractor, (refer to **Cutting Deck Removal** on page 25) then gently flip the deck over to expose its underside.
- Place a block of wood between the center deck housing baffle and the cutting blade to act as a stabilizer. See Figure 24.

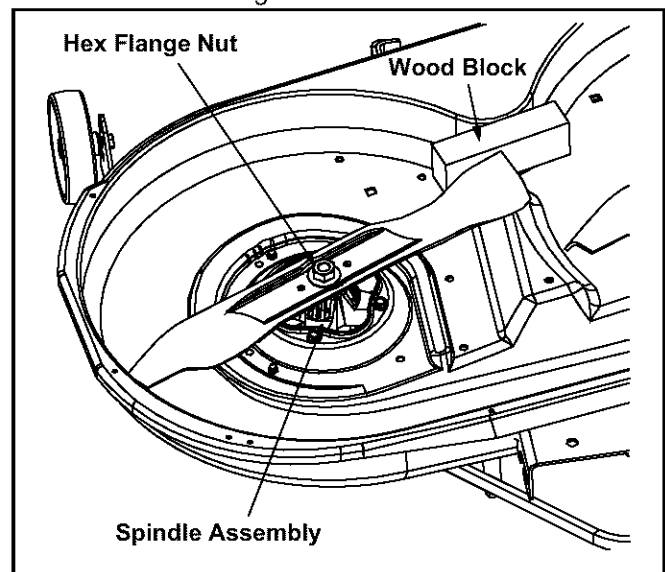

Figure 24

- Use a 1-1/8" wrench to remove the hex flange nut that secures the blade to the spindle assembly. See Figure 24.

To properly sharpen the cutting blades, remove equal amounts of metal from both ends of the blades along the cutting edges, parallel to the trailing edge, at a 25° to 30° angle. **IMPORTANT:**

IMPORTANT: If the cutting edge of the blade has already been sharpened, or if any metal separation is present, replace the blades with new ones.

It is important that each cutting blade edge be ground equally to maintain proper blade balance. A poorly balanced blade will cause excessive vibration and may cause damage to the tractor and result in personal injury.

The blade can be tested by balancing it on a round shaft screwdriver. Grind metal from the heavy side until it balances evenly.

IMPORTANT: When replacing the blade, be sure to install the blade with the side of the blade marked "Bottom" (or with a part number stamped in it) facing the ground when the mower is in the operating position.

IMPORTANT: Use a torque wrench to tighten the blade spindle hex flange nut to between 70 and 90 ft/lbs.

Battery

The battery is sealed and is maintenance-free. Acid levels cannot be checked and fluid can not be added.

- Always keep the battery cables and terminals clean and free of corrosive build-up.
- After cleaning the battery and terminals, apply a light coat of petroleum jelly or grease to both terminals
- Always keep the rubber boot positioned over the positive terminal to prevent shorting.

IMPORTANT: If removing the battery for any reason, disconnect the NEGATIVE (Black) wire from its terminal first, followed by the POSITIVE (Red) wire. When re-installing the battery, always connect the POSITIVE (Red) wire its terminal first, followed by the NEGATIVE (Black) wire. Be certain that the wires are connected to the correct terminals; reversing them could change the polarity and cause damage to your engine's alternating system.

Jump Starting



WARNING: Never jump start a damaged or frozen battery. Be certain the vehicles do not touch, and ignitions are off. Do not allow cable clamps to touch.

- Connect positive (+) cable to positive post (+) of your tractor's discharged battery.
- Connect the other end of the cable to the (positive +) post of the jumper battery.
- Connect the second cable (negative -) to the other post of the jumper battery.

- Make the final connection on the engine block of the stalled tractor, away from the battery. Attach to a unpainted part to assure a good connection.

IMPORTANT: If the jumper battery is installed on a vehicle (i.e. car, truck), do NOT start the vehicle's engine when jump starting your tractor.

- Refer to the instructions on page 13 to start the tractor .
- Set the tractor's parking brake before removing the jumper cables, in reverse order of connection.
- Allow the tractor's engine to run for 15 minutes before shutting it off to allow the alternating system time to charge the discharged battery.

Charging

If the unit has not been put into use for an extended period of time, charge the battery with an automotive-type 12-volt charger for a minimum of one hour at six amps.



WARNING: Batteries give off an explosive gas while charging. Charge battery in a well ventilated area and keep away from an open flame or pilot light as on a water heater, space heater, furnace, clothes dryer or other gas appliances.

Fuse

A fuse is installed in your tractor's wiring harness to protect the tractor's electrical system from damage caused by excessive amperage.

If the electrical system does not function, or your tractor's engine will not crank, first check to be certain that the fuse has not blown.

It can be found under the hood mounted behind the top of the dash panel on the support bar. Pull the fuse out and inspect it to determine if it is good or blown.

IMPORTANT: Always use a fuse with the same amperage capacity for replacement.



WARNING: Before servicing, repairing, or inspecting, always disengage PTO, set parking brake, stop engine and remove key to prevent unintended starting.

Cutting Deck Removal

To remove the cutting deck, proceed as follows:

- Place the PTO knob in the disengaged (OFF) position and engage the parking brake.
- Lower the deck by moving the deck lift lever into the bottom notch on the right fender.
- Remove the PTO belt from around the tractor's electric PTO clutch. Refer to Figure 26 or Figure 27.
- Looking at the cutting deck from the left side of the tractor, locate the deck support pin on the rear left side of the deck. Refer to Figure 25.

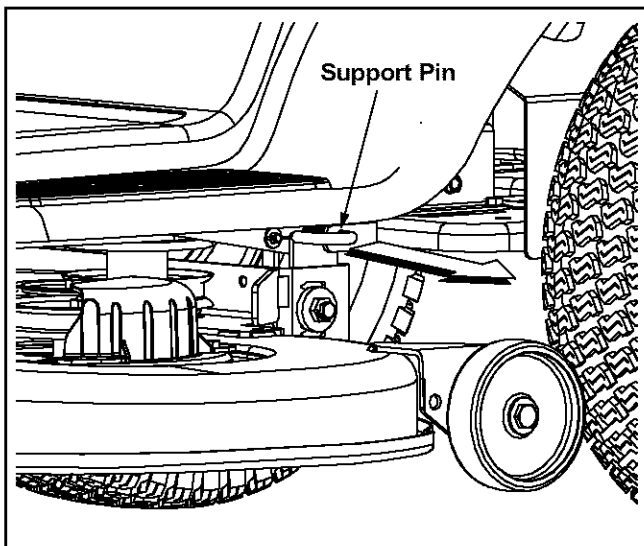

Figure 25

- Rotate the pin slightly toward the rear of the tractor and release the pin into the hole provided.
- Pull the deck support pin outward to release the deck from the deck lift arm. See Figure 25.
- Repeat the above steps on the tractor's right side.
- Move the deck lift lever into the top notch on the right fender to raise the deck lift arms up and out of the way.
- Gently slide the cutting deck toward the front of the tractor allowing the hooks on the deck to release themselves from the deck stabilizer rod.
- Gently slide the cutting deck (from the right side) out from underneath the tractor.

Changing the Deck Belt(s)



WARNING: Be sure to shut the engine off, remove ignition key, disconnect the spark plug wire(s) and ground against the engine to prevent unintended starting before removing the belt(s).

All belts on your tractor are subject to wear and should be replaced if any signs of wear are present.

IMPORTANT: The V-belts found on your tractor are specially designed to engage and disengage safely. A substitute (non-OEM) V-belt can be dangerous by not disengaging completely. For a proper working machine, use factory approved belts.

To change or replace the deck belts on your tractor, proceed as follows:

- Lower the deck by moving the deck lift lever into the bottom notch on the right fender.
- Remove the belt guards by removing the self-tapping screws that fasten them to the deck. See Figure 26 or Figure 27.
- Grasp the rearmost portion of the PTO idler bracket and pivot it toward the discharge chute to relieve tension on the PTO belt.
- Remove the PTO belt from the electric PTO clutch and the PTO idler pulley(s).
- Grasp the deck idler pulley and pivot it toward the left side of the deck to relieve tension on the deck belt.

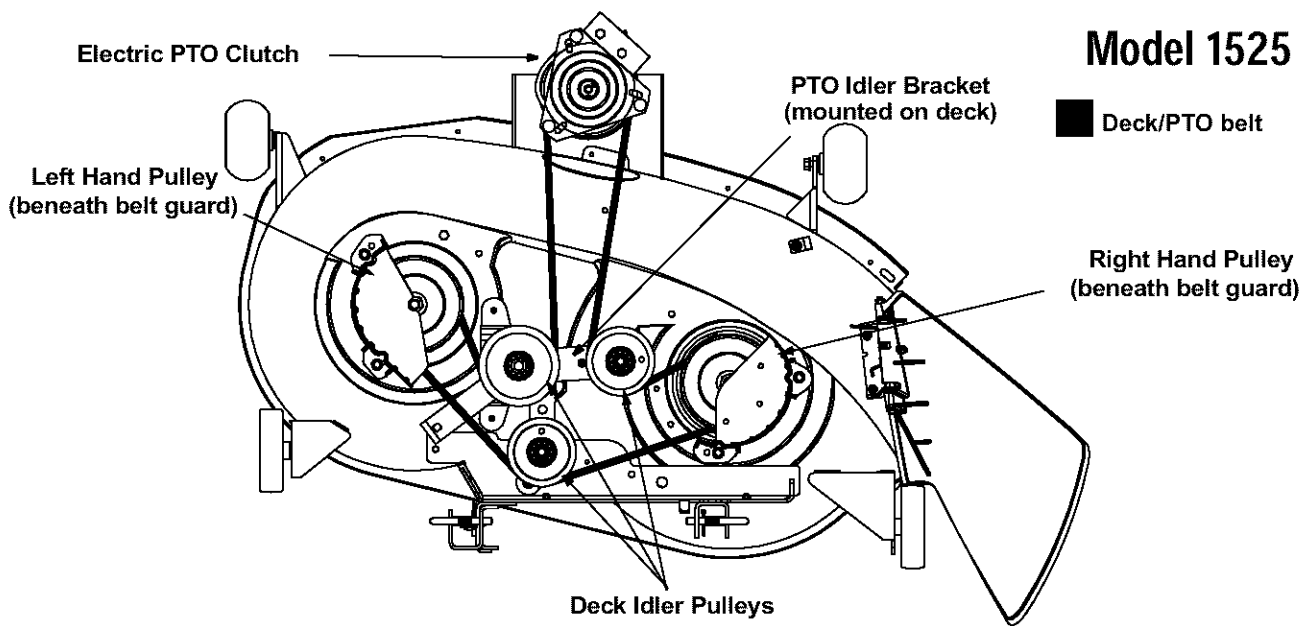

Figure 26

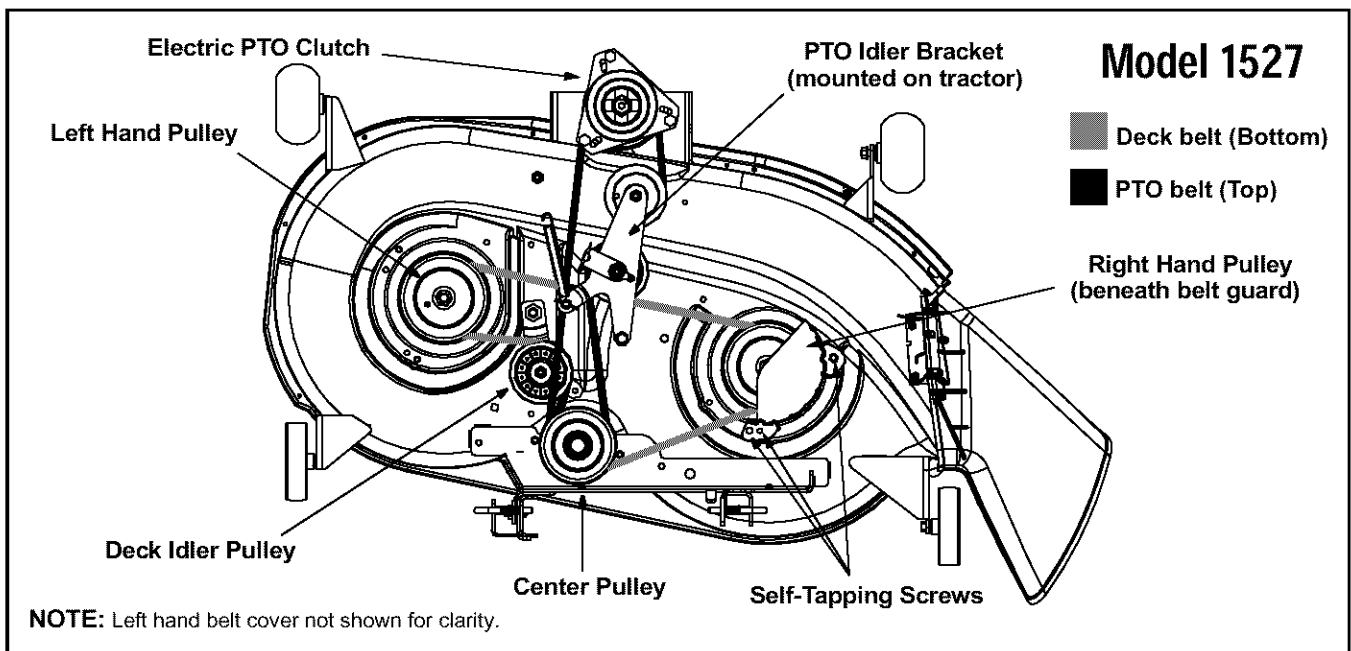

Figure 27

- Remove the deck belt from around all pulleys, including the deck idler pulley.
- Route the new belts as shown in Figure 26 or Figure 27.
- Remount the belt guards removed earlier.

Changing The Transmission Drive Belt

All belts on your tractor are subject to wear and should be replaced if any signs of wear are present.

IMPORTANT: The V-belts found on your tractor are specially designed to engage and disengage safely. A substitute (non-OEM) V-belt can be dangerous by not disengaging completely. For a proper working machine, use factory approved belts.

To change or replace the drive belt on your tractor, proceed as follows:

- Remove the cutting deck as instructed earlier in this section.
- After disconnecting the battery cables, remove the battery and battery tray from beneath the seat.

IMPORTANT: When removing the battery, disconnect the NEGATIVE (Black) wire from it's terminal first, followed by the POSITIVE (Red) wire. Re-install in reverse order.

NOTE: Proper removal of the drive belt requires the removal of several tractor components. Read through the following procedure prior to attempting it to determine if you feel you could successfully complete it. If you don't, see your Cub Cadet dealer to have the belt changed.

IMPORTANT: Note the routing of the lower drive belt around all the pulleys and the belt keepers (if present) BEFORE performing the following steps.

- Locate the fixed v-idler pulley found on the left underside of the frame. See Figure 28.
- Grasp the belt on both sides of the pulley and gently move it toward the left frame rail allowing it to unseat itself from the fixed v-idler. See Figure 28.
- Pivot the double-idler bracket forward slightly before removing the idler extension spring from the stud and the double-idler bracket itself. Do NOT discard the spring.
- Roll the drive belt out from around both the v-idler pulley and the flat idler pulley found on the double-idler bracket.
- Carefully unplug the tractor's wire harness from the connector on the electric PTO clutch.
- Note the orientation of the electric PTO clutch. Remove the hex bolt from the center of the electric PTO clutch and gently lower it off of the engine crankshaft.
- Be careful not to lose any washers or spacers which may be found on top of the electric PTO clutch.
- The engine pulley is located directly above the electric PTO clutch. Lower the engine pulley far enough to be able to remove the upper drive belt from around it.

IMPORTANT: When remounting the electric PTO clutch, make certain that it is properly oriented against the anti-rotation bracket prior to securing it to the engine's crankshaft. Torque the center hex bolt to between 38 foot-pounds and 50 foot-pounds.

- Remove the drive belt by feeding it from front to rear, toward the hydrostatic transmission. See Figure 28.
- Continue removing the drive belt by gently lifting it off of the transmission pulley and over the cooling fan.

IMPORTANT: The fins on the cooling fan are only slightly flexible. Be careful not to damage the fan when removing the drive belt from around the transmission pulley.

- Reroute the new belt around the pulleys and belt keepers, if present, EXACTLY as the old one was routed. Refer to Figure 28.

Hydrostatic Transmission

The hydrostatic transmission is sealed at the factory and is maintenance free. The fluid level cannot be checked nor can the oil be changed. Always keep the area around the transmission cooling fan free of grass and debris at all times.

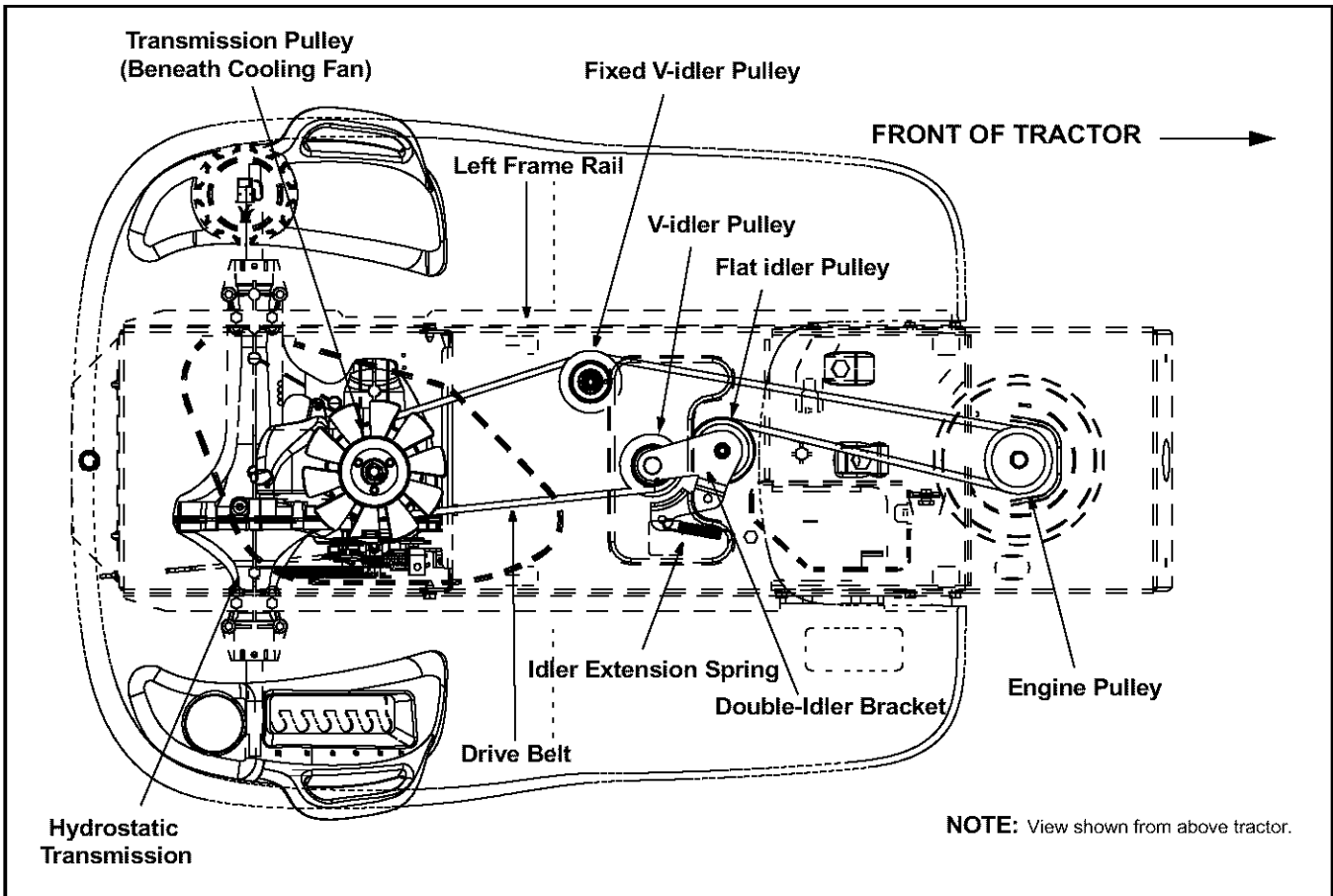

Figure 28

SECTION 9: OFF-SEASON STORAGE

Clean and lubricate the tractor as instructed in **Section 7: MAINTAINING YOUR LAWN TRACTOR** before storing for an extended period.

Engine

If the engine will be out of service for 30 days or more, the fuel system must be completely emptied, or the gasoline must be treated with a fuel stabilizer to prevent deterioration.

If you choose to use a stabilizer, fill the fuel tank with clean, fresh gasoline. Following the manufacturers recommendations, add the correct amount of stabilizer for the capacity of the fuel system. Run the engine for 2-3 minutes to get stabilized fuel into the carburetor.

If you choose to empty the system, drain any large volume of fuel from the tank by disconnecting the fuel line from the in-line fuel filter near the engine.



WARNING: Drain fuel only into an approved container outdoors, away from an open flame. Allow engine to cool. Extinguish cigarettes, cigars, pipes, and other sources of ignition prior to draining fuel.

- **Model 1525:** Reconnect the fuel line and run the engine until it starts to falter, then use the choke to keep the engine running until all fuel in the carburetor has been exhausted.
- **Model 1527:** Place a small container beneath the carburetor bowl. Accessing the bowl drain screw from behind the right side of the air cleaner (see

Figure 29), use a phillips screwdriver to loosen the bowl drain screw and drain the bowl.

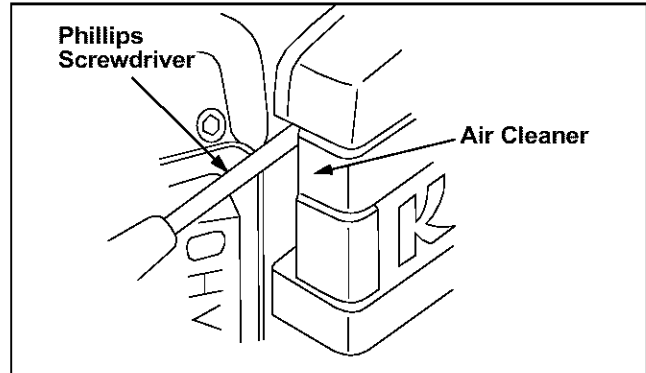

Figure 29

- Clean the exterior surfaces of the engine.
- Change the oil and filter. Refer to **Changing the Engine Oil** on page 20.
- Remove the spark plugs. Add one tablespoon of engine oil into the spark plug holes. Install the plugs, but do not reconnect the plug wires. Crank the engine two or three revolutions.
- Store the engine in a clean, dry place.



WARNING: Never store the machine or fuel container indoors where there is an open flame, spark or pilot light such as on water heater, furnace, clothes dryer or other gas appliance.

SECTION 10: MAINTENANCE CHART

	Before Each Use	After Initial 8 Hours	Every 10 Hours	Every 25 Hours	Every 100 Hours	Every Season	Prior to Storing
Clean Grille, Engine Screen and Side Panel Screens			✓				✓
Check Engine Oil Level	✓						
Clean Air Filter's Foam Precleaner				✓			
Replace Air Filter Element					✓	✓	
Change Engine Oil & Filter		✓			✓	✓	
Clean Battery Terminals			✓				✓
Lube Front Axles and Rims				✓			✓
Clean Engine Cooling Fins					✓		✓
Lube Front Deck Wheels				✓			✓
Lube Deck Spindles			✓				✓
Lube Pedal Pivot Points						✓	✓
Check Spark Plug					✓	✓	✓

SECTION 11: TROUBLESHOOTING

Trouble	Possible Cause(s)	Corrective Action
Engine fails to start	PTO knob engaged. Parking brake not engaged. Spark plug wire(s) disconnected. Throttle control lever not in correct starting position. Choke not activated Fuel tank empty, or stale fuel. Blocked fuel line. Faulty spark plug. Engine flooded.	Place knob in disengaged (OFF) position. Engage parking brake. Connect wire to spark plug. Place throttle lever to FAST position. Pull out the CHOKE control. Fill tank with clean, fresh (less than 30 days old) gas. Clean fuel line or replace fuel filter. Clean, adjust gap to .030" or replace plug. Crank engine with throttle in FAST position.
Engine runs erratic	Unit running with CHOKE applied. Spark plug wire loose. Blocked fuel line or stale fuel. Vent in gas cap plugged. Water or dirt in fuel system. Dirty air cleaner.	Push CHOKE control in. Connect and tighten spark plug wire. Clean fuel line; fill tank with clean, fresh (less than 30 days old) gasoline. Replace fuel filter, if so equipped. Clear vent or replace cap if damaged. Drain fuel tank. Refill with clean, fresh (less than 30 days old) gasoline. Replace air cleaner paper element or clean foam pre-cleaner.
Engine overheats	Engine oil level low. Air flow restricted.	Fill crankcase with proper capacity and weight of oil. Clean grass clippings and debris from around the engine's cooling fins and blower housing.
Engine hesitates at high RPM	Spark plug gap too close.	Remove spark plug and reset the gap to .030".
Idles poorly	Spark plug fouled, faulty or gap too wide. Dirty air cleaner.	Replace spark plug. Set plug gap to .030". Replace air cleaner cartridge/element or clean pre-cleaner.
Excessive vibration	Cutting blade loose or unbalanced. Damaged or bent cutting blade.	Tighten blade and spindle. Balance blade. Replace blade.
Mower will not mulch grass	Engine speed too low. Wet grass. Excessively high grass. Dull blade.	Place throttle in FAST (rabbit) position. Do not mow when grass is wet; wait until later to cut. Mow once at a high cutting height, then mow again at desired height or make a narrower cutting swath. Sharpen or replace blade.
Uneven cut	Deck not balanced properly. Dull blade. Uneven tire pressure.	Perform side-to-side deck adjustment. Sharpen or replace blade. Check tire pressure in all four tires.

SECTION 12: SPECIFICATIONS

	1525	1527
Capacities		
Fuel Tank	3 gallons (11.4 liters)	3 gallons (11.4 liters)
Crankcase (approximately)	1.8 quarts / 57.6 oz. (1.7 liters)	1.8 quarts / 57.6 oz. (1.7 liters)
Transmission Case (approximately)	4.9 pints / 78.8 oz. (2.3 liters)	4.9 pints / 78.8 oz. (2.3 liters)
Hydrostatic Transmission		
Make and Model	<i>Hydro-Gear 311-0710</i>	<i>Hydro-Gear 311-0710</i>
Gear Ratio	22.2:1	22.2:1
Forward Speed	0 m.p.h. - 5.5 m.p.h.	0 m.p.h. - 5.5 m.p.h.
Reverse Speed	0 m.p.h. - 2.5 m.p.h.	0 m.p.h. - 2.5 m.p.h.
Engine (Air-cooled, 4-cycle, Gasoline, OHV)		
Make and Model	<i>Kawasaki FH430V</i>	<i>Kawasaki FH500V</i>
Cylinders	Twin	Twin
Bore	2.56 in. (65 mm)	2.68 in. (68 mm)
Stroke	2.56 in. (65 mm)	2.68 in. (68 mm)
Displacement	26.3 cu. in. (431 mL)	30.15 cu. in. (494 mL)
Maximum Power @3600 RPM	15 HP (11.2 kW)	17 HP (12.7 kW)
Maximum Torque @2400 RPM	23.6 lbs. ft. (32 Nm)	25.1 lbs. ft. (34 Nm)
Compression Ratio	8:5:1	8:5:1
Engine Speed (governed)		
Low Speed	1200 RPM	1200 RPM
High Speed (no load)	3500 RPM (± 100 RPM)	3500 RPM (± 100 RPM)
Spark Plug Gap	.030 in. (.75 mm)	.030 in. (.75 mm)
Electrical System		
System Voltage	12-volt Negative Ground	12-volt Negative Ground
Battery	270 CCA (sealed)	270 CCA (sealed)
Alternator	13 Amp Regulated	13 Amp Regulated
Fuse (automotive type)	20 Amp	20 Amp
Headlights	Incandescent	Incandescent
Brakes	Single Disc (Dry)	Single Disc (Dry)
Turf Tires		
Front (inches)	15 x 6 x 6	15 x 6 x 6
Rear (inches)	20 x 9 x 8	20 x 9 x 8
Dimensions		
Wheelbase	47 in. (119.4 cm)	47 in. (119.4 cm)
Length, over all	68 in. (172.7 cm)	68 in. (172.7 cm)
Width, over all (w/ mower deck - chute up)	45 in. (114.3 cm)	45 in. (114.3 cm)
Height, over all (to top of steering wheel)	43 in. (109.2 cm)	43 in. (109.2 cm)
Ground Clearance	6 in. (15.2 cm)	6 in. (15.2 cm)
Turning Radius	18 in. (46 cm)	18 in. (46 cm)
Weight (approximate)	502 lb (225.9 kg)	504 lb (226.8 kg)

SECTION 13: ATTACHMENTS & ACCESSORIES

The following attachments and accessories are compatible for **Model 1525 & Model 1527**. See your *Cub Cadet* dealer or the retailer from which you purchased your tractor for information regarding price and availability.

NOTE: *Cub Cadet* lawn tractor models 1525 and 1527 are NOT designed for use with any type of ground-engaging attachments (e.g. tiller or mulchboard plow). Use of this type of equipment WILL void the tractor's warranty.

MODEL	DESCRIPTION
Attachments	
190-604-101	Yard-Mate™ Storage Container/Toolbox (mounts on rear of tractor)
(CC-)190-670(-100)*	Twin Bagger Grass Collector
(CC-)190-671(-100)*	Rear Tire Chain Set (20" x 9")
(CC-)190-672(-100)*	Front Bumper Kit
(CC-)190-673(-100)*	42-inch Two-stage Snow Thrower
(CC-)190-674(-100)*	46-inch Front Dozer Blade
(CC-)190-675(-100)*	Rear Wheel Weight Set
Accessories	
Model 1525	
490-200-0003	Air Filter — <i>Kawasaki</i> 11013-7017 — Pre-Cleaner <i>Kawasaki</i> 11013-7016
Model 1527	
490-200-0004	Air Filter — <i>Kawasaki</i> 11013-7002 — Pre-Cleaner <i>Kawasaki</i> 11013-7001
490-201-0001	Oil Filter <i>Kawasaki</i> 49065-2078
490-240-0001	Fuel Filter <i>Kawasaki</i> 49019-7001
490-250-0007	Spark Plug (<i>Champion</i> ® RCJ8Y, <i>Kawasaki</i> 92070-7003)
CC-742-3032	38-inch Cutting Blade Set (Model 1525)
CC-742-3033	42-inch Cutting Blade Set (Model 1527)
CC-754-0640	Transmission Drive Belt
CC-754-0641	PTO / Deck Belt (Model 1525)
CC-754-0644	PTO Belt (Model 1527)
CC-754-0645	Deck Belt (Model 1527)
759-3940A	<i>Cub Cadet</i> Yellow Touch Up Paint (11.5oz Aerosol)
759-3735A	<i>Cub Cadet</i> Beige Touch Up Paint (11.5oz Aerosol)
737-3029	SAE 30 (1 qt.)
737-3030B	10w-30 Oil (1 qt.)
737-3049	5w-30 Oil (1 qt.)

* Attachments purchased through a merchandise retailer may have a "CC" model number prefix. Attachments purchased through your *Cub Cadet* dealer may have a "100" model number suffix.

**KAWASAKI LIMITED WARRANTY
CALIFORNIA AND FEDERAL
EMISSIONS CONTROL SYSTEMS
SMALL OFF-ROAD ENGINES**

The California Air Resources Board, the Environmental Protection Agency (EPA) , and Kawasaki Motors Corp., U.S.A. (hereinafter "Kawasaki") are pleased to explain the Emission Control Systems Warranty on your Kawasaki small off-road engine. In California and other states, new small off-road engines must be designed, built and equipped to meet the stringent anti-smog standards. Kawasaki must warrant the emission control system on your small off-road engine for the period of time listed below provided there has been no abuse, neglect, or improper maintenance of your small off-road engine. Your emission control system may include parts such as the carburetor or fuel-injection system, the ignition system, and catalytic converter. Also included may be hoses, belts, connectors and other emission related assemblies. Where a warrantable condition exists, Kawasaki will repair your small off-road engine at no cost to you including diagnosis (if the diagnostic work is performed at a Kawasaki small off-road engine dealer), parts and labor.

OWNERS WARRANTY RESPONSIBILITIES. The following obligations must be fulfilled by the owner to maintain the validity of the Kawasaki California / EPA Emission Systems Warranty:

- (a) As the small off-road engine owner, you are responsible for the performance of the required maintenance listed in your owner's manual. Kawasaki recommends that you retain all receipts covering maintenance on your small off-road engine, but Kawasaki cannot deny warranty solely for the lack of receipts or for your failure to ensure the performance of all scheduled maintenance.
 - (b) You are responsible for presenting your small off-road engine to an authorized Kawasaki small off-road engine dealer as soon as a problem exists. The warranty repairs should be completed in a reasonable amount of time, not to exceed 30 days.
 - (c) As the small off-road engine owner, you should also be aware that Kawasaki may deny you warranty coverage if your small off-road engine or a part has failed due to abuse, neglect, improper maintenance or unapproved modifications.
 - (d) If you have any questions regarding your warranty right and responsibilities, you should contact Kawasaki Motors Corp., U.S.A., Consumer Services Department, 5080 36th Street S.E., Grand Rapids, MI 49512, (616)949-6500.
1. **COVERAGE.** Kawasaki warrants to the initial owner and each subsequent purchaser that the small off-road engine is free from defects in material and workmanship which cause a failure of a warranted part for a period of two years. Kawasaki is liable for damages to other engine components caused by the failure of a warranted part still under warranty. The 1995 and later small off-road engines are warranted for two years in California. In all other states, 1997 and later model year small off-road engines are warranted for two years. If any emission-related part on your engine is defective, the part will be repaired or replaced by Kawasaki. This warranty time period shall begin on the date the small off-road engine is delivered to the initial purchaser, or on the date the small off-road engine is first placed in service.

Warranty defects shall be remedied during customary business hours at any authorized Kawasaki small off-road engine dealer located within the United States of America. Any manufacturer-approved replacement part may be used in the performance of any warranty maintenance or repairs on emission-related parts, and must be provided without charge to the owner if the part is still under warranty. Any part or parts replaced under this warranty shall become the property of Kawasaki.

The emission related warranted parts are specifically defined by the California Air Resources Board's Emission Warranty Parts List. (EPA's regulations do not include a parts list, but EPA considers emission-related parts to include all parts listed here.) These warranted parts are: carburetor and internal parts, spark advance/retard system, cold start enrichment system, magneto or electronic ignition system, catalytic converter, intake manifold, exhaust manifold, air cleaner element, and spark plugs if failure occurs prior to the first required scheduled replacement, hoses, clamps, fittings, gaskets, sealing devices, mounting hardware and tubing used directly in these parts.

Since emission related parts may vary slightly from model to model, certain models may not contain all of these parts and certain models may contain functionally equivalent parts.

2. **LIMITATIONS.** This Emission Control Systems Warranty shall not cover any of the following:
- (a) Repair or replacement required as a result of (i) misuse or neglect, (ii) lack of required maintenance, (iii) repairs improperly performed or replacements improperly installed, (iv) use of replacement parts or accessories not conforming to Kawasaki specifications which adversely affect performance and/or durability, (v) alterations or modifications not recommended or approved in writing by Kawasaki.
 - (b) Replacement of parts and other services and adjustments necessary for required maintenance at and after the first scheduled replacement point.

3. **LIMITED LIABILITY.**

(a) The liability of Kawasaki under this Emission Control Systems Warranty is limited solely to the remedying of defects in materials or workmanship by any authorized Kawasaki small off-road engine dealer at its place of business during customary business hours. This warranty does not cover inconvenience or loss of use of the small off-road engine or transportation of the small off-road engine to or from the Kawasaki dealer. KAWASAKI SHALL NOT BE LIABLE FOR ANY OTHER EXPENSE, LOSS OR DAMAGE, WHETHER DIRECT, INCIDENTAL, CONSEQUENTIAL (EXCEPTION LISTED UNDER COVERAGE) OR EXEMPLARY ARISING IN CONNECTION WITH THE SALE OR USE OF OR INABILITY TO USE THE KAWASAKI SMALL OFF-ROAD ENGINE FOR ANY PURPOSE.

(b) NO EXPRESS EMISSION CONTROL SYSTEMS WARRANTY IS GIVEN BY KAWASAKI WITH RESPECT TO THE KAWASAKI SMALL OFF-ROAD ENGINE EXCEPT AS SPECIFICALLY SET FORTH HEREIN. ANY EMISSION CONTROL SYSTEMS WARRANTY IMPLIED BY LAW, INCLUDING ANY WARRANTY OF MERCHANTABILITY OR FITNESS FOR A PARTICULAR PURPOSE, IS EXPRESSLY LIMITED TO THE EMISSION CONTROL SYSTEMS WARRANTY TERMS SET FORTH HEREIN. THE FOREGOING STATEMENTS OF WARRANTY ARE EXCLUSIVE AND IN LIEU OF ALL OTHER REMEDIES.

(c) No dealer is authorized to modify this Kawasaki Limited Emission Control System Warranty.

(d) Kawasaki is not liable for parts which are not genuine Kawasaki parts except when genuine Kawasaki parts cause damage to non-Kawasaki parts.

5. **LEGAL RIGHTS.** THIS WARRANTY GIVES YOU SPECIFIC LEGAL RIGHTS, AND YOU MAY ALSO HAVE OTHER RIGHTS.

6. THIS WARRANTY IS IN ADDITION TO THE KAWASAKI LIMITED SMALL OFF-ROAD ENGINE WARRANTY.

CUB CADET LLC

MANUFACTURER'S ONE YEAR LIMITED WARRANTY

(COMMERCIAL USE)

The limited warranty set forth below is given by CUB CADET LLC ("CUB CADET") with respect to new merchandise purchased and used in the United States, its possessions and territories.

CUB CADET warrants this product against defects in material and workmanship for a period of one (1) year for commercial users, commencing on the date of original purchase and will, at its option, repair or replace, free of charge, any part found to be defective in material or workmanship. This limited warranty shall only apply if this product has been operated and maintained in accordance with the Operator's Manual furnished with the product, and has not been subject to misuse, abuse, neglect, accident, improper maintenance, alteration, vandalism, theft, fire, water or damage because of other peril or natural disaster.

Batteries and belts are subject to separate terms as follows:

a. Batteries have a one-year prorated limited warranty with 100% replacement during the first three months. After three months, the battery replacement credit is based on the months remaining in the twelve (12) month period dating back to the original date of sale. Any replacement battery will be warranted only for the remainder of the original warranty period.

b. All belts are covered by a one (1) year limited warranty against defects in material and workmanship.

HOW TO OBTAIN SERVICE: Warranty service is available, WITH PROOF OF PURCHASE, THROUGH YOUR LOCAL AUTHORIZED CUB CADET DEALER. To locate the dealer in your area, please check for a listing at www.cubcadet.com, or in the Yellow Pages or contact CUB CADET by calling 1-877-CUB TOUGH (1-877-282-8684) or writing to P.O. Box 361131, Cleveland, Ohio 44136-0019.

This limited warranty does not provide coverage in the following cases:

a. Routine maintenance items such as lubricants, filters, blade sharpening and tune-ups, or adjustments such as brake adjustments, clutch adjustments or deck adjustments; and normal deterioration of the exterior finish due to use or exposure.

b. Normal wear parts or components, including blades, blade adapters, grass bags, rider deck wheels, seats, snow thrower skid shoes, shave plates and tires.

CUB CADET does not extend any warranty for products sold or exported outside of the United States of America, its possessions and territories, except those sold through CUB CADET'S authorized channels of export distribution.

No implied warranty, including any implied warranty of merchantability or fitness for a particular purpose, applies after the applicable period of express written warranty above. No other express warranty or guaranty, whether written or oral, except as mentioned above, given by any person or entity, including the dealer, with respect to any product shall bind CUB CADET. During the period of the Warranty, the exclusive remedy is repair or replacement of the product as set forth above. (Some states do not allow limitations on how long an implied warranty lasts, so the above limitation may not apply to you.)

The provisions as set forth in this Warranty provide the sole and exclusive remedy arising from the sale. CUB CADET shall not be liable for incidental or consequential loss or damages including, without limitation, to any claim for loss of profits, loss of savings or revenue, loss of the use of the equipment or any associated equipment, facilities or service, downtime, the claims or costs of third parties including customers, and injury to property, and further including expenses incurred for substitute or replacement lawn care services, for transportation or for related expenses, or for rental expenses to temporarily replace a warranted product. (Some states do not allow the exclusion or limitation of incidental or consequential damages, so the above exclusion may not apply to you.)

In no event shall recovery of any kind be greater than the amount of the purchase price of the product sold. Alteration of the safety features of the product shall void this Warranty. You assume the risk and liability for loss, damage, or injury to you and your property and/or to others and their property arising out of the use or misuse or inability to use the product.

This limited warranty shall not extend to anyone other than the original purchaser or original lessee.

How State Law Relates to this Warranty: This limited warranty gives you specific legal rights, and you may also have other rights which vary from state to state.

CUB CADET LLC MANUFACTURER'S LIMITED WARRANTY (RESIDENTIAL USE)

The limited warranty set forth below is given by CUB CADET LLC ("CUB CADET") with respect to new merchandise purchased and used in the United States, its possessions and territories.

CUB CADET warrants this product against defects in material and workmanship for a period of two (2) years for residential users, (one (1) year for commercial users), commencing on the date of original purchase and will, at its option, repair or replace, free of charge, any part found to be defective in material or workmanship. This limited warranty shall only apply if this product has been operated and maintained in accordance with the Operator's Manual furnished with the product, and has not been subject to misuse, abuse, neglect, accident, improper maintenance, alteration, vandalism, theft, fire, water or damage because of other peril or natural disaster.

Batteries and belts are subject to separate terms as follows:

- a. Batteries have a one-year prorated limited warranty with 100% replacement during the first three months. After three months, the battery replacement credit is based on the months remaining in the twelve (12) month period dating back to the original date of sale. Any replacement battery will be warranted only for the remainder of the original warranty period.
- b. All belts are covered by a one (1) year limited warranty against defects in material and workmanship.

3 Year Limited Warranty - PTO Clutch

CUB CADET warrants the power take off ("PTO") clutch and mounting hardware against defects in material and workmanship for a period of three (3) years for Series 1500 products manufactured after August 1, 1997 for residential users, commencing on the date of original purchase or lease and CUB CADET will, at its option, repair or replace, free of charge, any PTO clutch or mounting hardware found to be defective in material or workmanship provided this product has been operated and maintained as set forth above.

5 Year/500 Hour Limited Warranty- Frame and Front Axle

CUB CADET warrants the frame, and front cast iron pivot axle on Series 1500 models against defects in material and workmanship for a period of five (5) years or 500 hours, whichever occurs first, for residential users, commencing on the date of original purchase or lease and CUB CADET will, at its option, repair or replace, free of charge, any part found to be defective in material or workmanship provided this product has been operated and maintained as set forth above. In addition to any other reason set forth herein, CUB CADET may deny warranty coverage if the hour meter, or any part thereof, is altered, modified, disconnected or otherwise tampered with.

HOW TO OBTAIN SERVICE: Warranty service is available, WITH PROOF OF PURCHASE, THROUGH YOUR LOCAL AUTHORIZED CUB CADET DEALER. To locate the dealer in your area, please check for a listing at www.cubcadet.com or in the Yellow Pages or contact CUB CADET by calling 1-877-CUB TOUGH (1-877-282-8684) or writing to P.O. Box 361131, Cleveland, Ohio 44136-0019.

This limited warranty does not provide coverage in the following cases:

- a. Routine maintenance items such as lubricants, filters, blade sharpening and tune-ups, or adjustments such as brake adjustments, clutch adjustments or deck adjustments; and normal deterioration of the exterior finish due to use or exposure.
- b. CUB CADET does not extend any warranty for products sold or exported outside of the United States of America, its possessions and territories, except those sold through CUB CADET's authorized channels of export distribution.
- c. Normal wear parts or components, including blades, blade adapters, grass bags, rider deck wheels, seats, snow thrower skid shoes, rubber auger spirals, shave plates and tires.

No implied warranty, including any implied warranty of merchantability or fitness for a particular purpose, applies after the applicable period of express written warranty above as to the parts as identified. No other express warranty or guaranty, whether written or oral, except as mentioned above, given by any person or entity, including the dealer, with respect to any product shall bind CUB CADET. During the period of the Warranty, the exclusive remedy is repair or replacement of the product as set forth above. (Some states do not allow limitations on how long an implied warranty lasts, so the above limitation may not apply to you.)

The provisions as set forth in this Warranty provide the sole and exclusive remedy arising from the sales. CUB CADET shall not be liable for incidental or consequential loss or damages including, without limitation, expenses incurred for substitute or replacement lawn care services, for transportation or for related expenses, or for rental expenses to temporarily replace a warranted product. (Some states do not allow the exclusion or limitation of incidental or consequential damages, so the above exclusion or limitation may not apply to you.)

In no event shall recovery of any kind be greater than the amount of the purchase price of the product sold. Alteration of the safety features of the product shall void this Warranty. You assume the risk and liability for loss, damage, or injury to you and your property and/or to others and their property arising out of the use or misuse or inability to use the product.

This limited warranty shall not extend to anyone other than the original purchaser or original lessee.

How State Law Relates to this Warranty: This limited warranty gives you specific legal rights, and you may also have other rights which vary from state to state.