

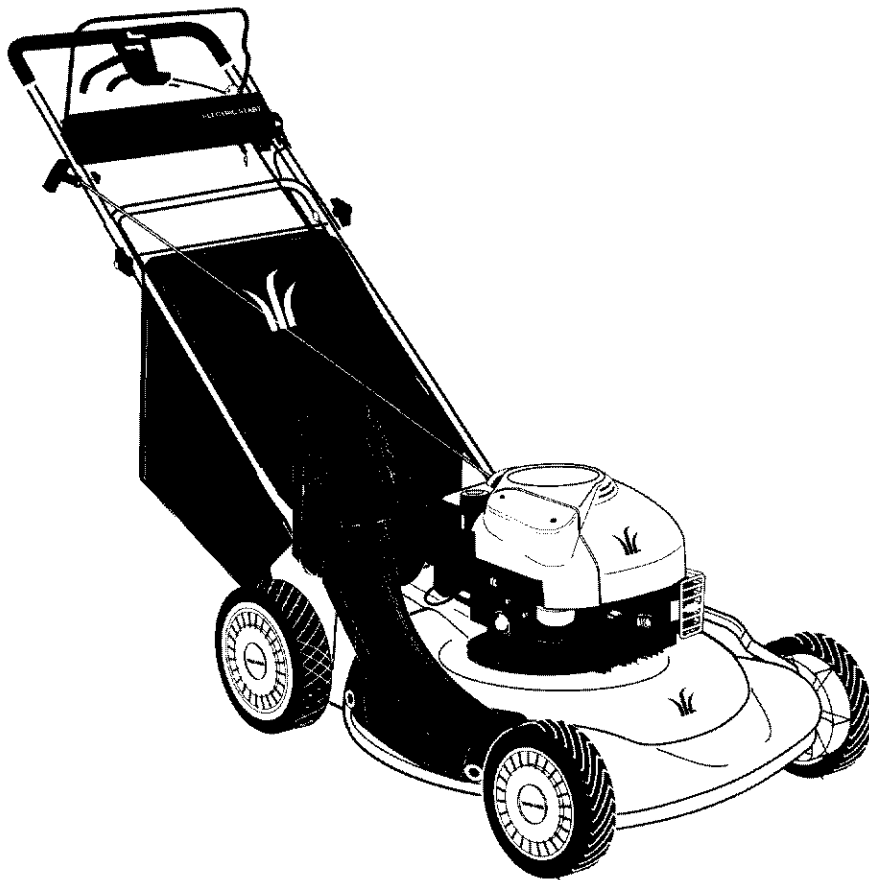

OWNER'S GUIDE



Model Shown E979

Model Series
950-959
970-979
E970-E979



IMPORTANT: READ SAFETY RULES AND INSTRUCTIONS CAREFULLY

Warning: This unit is equipped with an internal combustion engine and should not be used on or near any unimproved forest-covered, brush-covered or grass-covered land unless the engine's exhaust system is equipped with a spark arrester meeting applicable local or state laws (if any). If a spark arrester is used, it should be maintained in effective working order by the operator. In the State of California the above is required by law (Section 4442 of the California Public Resources Code). Other states may have similar laws. Federal laws apply on federal lands. A spark arrester for the muffler is available through your nearest engine authorized service dealer or contact the service department, P.O. Box 368022 Cleveland, Ohio 44136-9722.

MTD PRODUCTS INC. P.O. BOX 368022 CLEVELAND, OHIO 44136-9722

USE THIS PAGE AS A GUIDE TO DETERMINE SLOPES WHERE YOU MAY NOT OPERATE SAFELY.

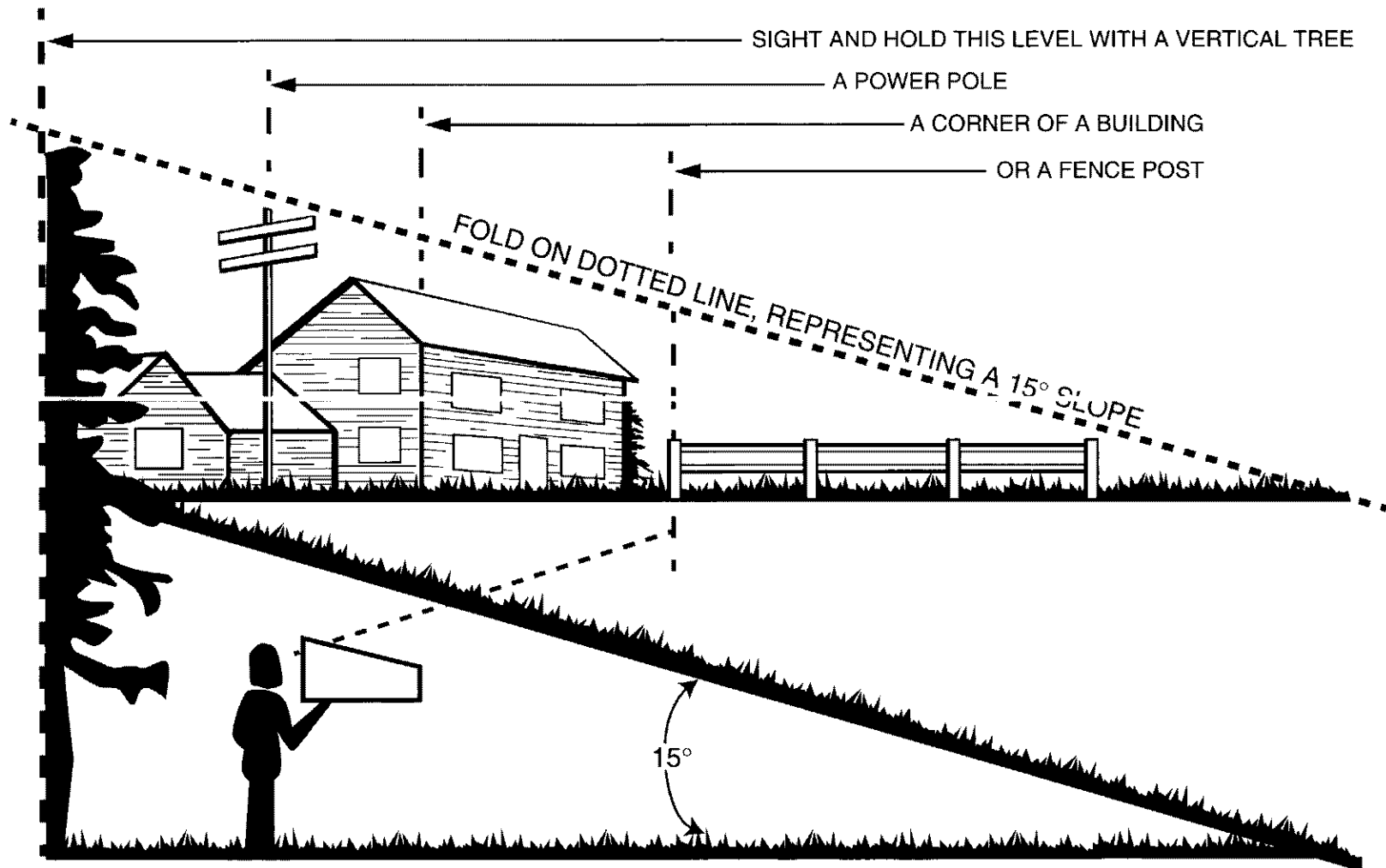

WARNING

Do not mow on inclines with a slope in excess of 15 degrees (a rise of approximately 2-1/2 feet every 10 feet). A riding mower could overturn and cause serious injury. If operating a walk-behind mower on such a slope, it is extremely difficult to maintain your footing and you could slip, resulting in serious injury.

Operate RIDING mowers up and down slopes, never across the face of slopes.

Operate WALK-BEHIND mowers across the face of slopes, never up and down slopes.

SECTION 2: IMPORTANT SAFE OPERATION PRACTICES



WARNING: THIS SYMBOL POINTS OUT IMPORTANT SAFETY INSTRUCTIONS WHICH, IF NOT FOLLOWED, COULD ENDANGER THE PERSONAL SAFETY AND/OR PROPERTY OF YOURSELF AND OTHERS. READ AND FOLLOW ALL INSTRUCTIONS IN THIS MANUAL BEFORE ATTEMPTING TO OPERATE YOUR LAWN MOWER. FAILURE TO COMPLY WITH THESE INSTRUCTIONS MAY RESULT IN PERSONAL INJURY. WHEN YOU SEE THIS SYMBOL, HEED ITS WARNING.



DANGER: Your lawn mower was built to be operated according to the rules for safe operation in this manual. As with any type of power equipment, carelessness or error on the part of the operator can result in serious injury. This lawn mower is capable of amputating hands and feet and throwing objects. Failure to observe the following safety instructions could result in serious injury or death.

1. GENERAL OPERATION

- Read this owner's guide carefully in its entirety before attempting to assemble this machine. Read, understand, and follow all instructions on the machine and in the manual(s) before operation. Be completely familiar with the controls and the proper use of this machine before operating it. Keep this manual in a safe place for future and regular reference and for ordering replacement parts.
- Your rotary mower is a precision piece of power equipment, not a plaything. Therefore, exercise extreme caution at all times. Your unit has been designed to perform one job: to mow grass. Do not use it for any other purpose.
- Never allow children under 14 years old to operate a power mower. Children 14 years old and over should only operate mower under close parental supervision. Only responsible individuals who are familiar with these rules of safe operation should be allowed to use your mower.
- Keep the area of operation clear of all persons, particularly small children and pets. Stop engine when they are in the vicinity of your mower to help prevent blade contact or thrown object injury. Although the area of operation should be completely cleared of foreign objects, an object may have been overlooked and could be accidentally thrown by the mower in any direction and cause serious personal injury to the operator or any others allowed in the area.
- Thoroughly inspect the area where the equipment is to be used. Remove all stones, sticks, wire, bones, toys and other foreign objects which could be picked up and thrown by the mower in any direction and cause serious personal injury to the operator or any others allowed in the area. Plan your mowing pattern to avoid discharge of material toward roads, sidewalks, bystanders and the like. To help avoid a thrown objects injury, keep children, bystanders and helpers at least 75 feet from the mower while it is in operation.
- Always wear safety glasses or safety goggles during operation or while performing an adjustment or repair, to protect eyes from foreign objects that may be thrown from the machine in any direction.
- Wear sturdy, rough-soled work shoes and close-fitting slacks and shirts. Shirts and pants that cover the arms and legs and steel-toed shoes are recommended. Do not wear loose fitting clothes or jewelry. They can be caught in moving parts. Never operate a unit in bare feet, sandals, slippery or light weight (e.g. canvas) shoes.
- Do not put hands or feet near or under rotating parts. Keep clear of discharge opening at all times as the rotating blade can cause injury.
- Many injuries occur as a result of the mower being pulled over the foot during a fall. Do not hang on to the mower if you are falling; release the handle immediately.
- Never pull the mower toward you while you are walking. If you must back the mower away from a wall or obstruction first look down and behind, and then follow these steps:
 - Step back from the mower to fully extend your arms.
 - Be sure you are well balanced with sure footing.
 - Pull the mower back slowly, no more than half way toward you.
 - Repeat these steps as needed.
- Do not operate the mower while under the influence of alcohol or drugs.
- Do not engage the self-propelled mechanism on units so equipped while starting engine.
- The blade control handle is a safety device. Never attempt to bypass its operation. Doing so makes the safety device inoperative and may result in personal injury through contact with the rotating blade. The blade control handle must operate easily in both directions and automatically return to the disengaged position when released.

- Never operate the mower in wet grass. Always be sure of your footing. A slip and fall can cause a serious personal injury. Keep a firm hold on the handle and walk, never run. If you feel you are losing your footing, RELEASE THE BLADE CONTROL HANDLE IMMEDIATELY and the blade will stop rotating within three seconds.
- Mow only in daylight or good artificial light.
- Stop the blade when crossing gravel drives, walks or roads.
- If the equipment should start to vibrate abnormally, stop the engine and check immediately for the cause. Vibration is generally a warning of trouble.
- Shut the engine off and wait until the blade comes to a complete stop before removing the grass catcher or unclogging the chute. The cutting blade continues to rotate for a few seconds after the engine is shut off. Never place any part of the body in the blade area until you are sure the blade has stopped rotating.
- Never operate mower without proper guards, grass catcher, plates or other safety protective devices in place.
- Muffler and engine become hot and can cause a burn. Do not touch.
- Only use accessories approved for this machine by the manufacturer. Read, understand, and follow all instructions provided with the approved accessory.
- If situations occur which are not covered in this manual, use care and good judgment. Contact your dealer for assistance. Telephone 1-800-300-7310 for the name of your nearest dealer.

2. SLOPE OPERATION

For your safety, use the slope gauge included as part of this manual to measure slopes before operating this unit on a sloped or hilly area. If the slope is greater than 15 degrees as shown on the slope gauge, do not operate this unit on that area or serious injury could result.

DO:

- Mow across the face of slopes; never up and down. Exercise extreme caution when changing direction on slopes.
- Watch for holes, ruts, hidden objects, or bumps. Tall grass can hide obstacles.
- Always be sure of your footing. A slip and fall can cause serious personal injury. If you feel you are losing your balance release the blade control handle immediately and the blade will stop in less than 3 seconds.

DO NOT:

- Do not mow near drop-offs, ditches or embankments. The operator could lose footing or balance.

- Do not mow slopes greater than 15 degrees as shown on the slope gauge.
- Do not mow on wet grass. Reduced footing could cause slipping.

3. CHILDREN

Tragic accidents can occur if the operator is not alert to the presence of children. Children are often attracted to the mower and the mowing activity. Never assume that children will remain where you last saw them.

- Keep children out of the mowing area and under the watchful care of a responsible adult other than the operator.
- Be alert and turn mower off if a child enters the area.
- Before and while moving backwards, look behind and down for small children or other objects.
- Never allow children under age 14 to operate the mower. Children 14 years of age and above should read and understand the operation instructions and safety rules in this manual.
- Use extreme care when approaching blind corners, shrubs, trees, or other objects that may obscure your vision of a child or hazard.

4. SERVICE

- Use extreme care in handling gasoline and other fuels. They are extremely flammable and the vapors are explosive.
- Use only an approved gasoline container.
- Never remove gas cap or add fuel while the engine is running. Allow engine to cool at least two minutes before refueling.
- Replace gasoline cap securely and wipe off any spilled gasoline before starting the engine as it may cause a fire or explosion.
- Extinguish all cigarettes, cigars, pipes and other sources of ignition.
- Never refuel machine indoors because flammable vapors will accumulate in the area.
- Never store the machine or fuel container inside where there is an open flame or spark such as a gas water heater, space heater, or furnace.
- Never run an engine inside a closed area.
- To reduce fire hazard, keep mower free of grass, leaves, or other debris build-up. Clean up oil or fuel spillage. Allow mower to cool at least 5 minutes before storing.
- Before cleaning, repairing, or inspecting, make certain the blade and all moving parts have stopped. Disconnect the spark plug wire, and keep the wire away from the spark plug to prevent accidental starting.
- Check the blade and engine mounting bolts at frequent intervals for proper tightness. Also, visually inspect blade for damage (e.g., bent, cracked or

worn). Replace with blade which meets original equipment specifications listed in this manual.

- Keep all nuts, bolts, and screws tight to be sure the equipment is in safe working condition.
- Never tamper with safety devices. Check their proper operation regularly.
- After striking a foreign object, stop the engine, remove the wire from the spark plug, and thoroughly inspect the mower for any damage. Repair the damage before starting and operating the mower.
- Never attempt to make a wheel or cutting height adjustment while the engine is running.

- Grass catcher components are subject to wear, damage and deterioration, which could expose moving parts or allow objects to be thrown. For safety protection, frequently check components and replace with manufacturer's recommended parts, when necessary.
- Mower blades are sharp and can cut. Wrap the blade(s) or wear gloves, and use extra caution when servicing them.
- Do not change the engine governor setting or overspeed the engine. Excessive engine speeds are dangerous.



WARNING - YOUR RESPONSIBILITY: Restrict the use of this power machine to persons who read, understand and follow the warnings and instructions in this manual and on the machine.



Figure 1 Safety Labels Found On Lawn Mower

SECTION 3: FINDING YOUR MODEL NUMBER

This Owner's Guide is an important part of your new lawn mower. It will help you assemble, prepare and maintain your mower. Please read and understand what it says.

Before you start to prepare your mower for its first use, please locate the model plate and copy the information from it in this Owner's Guide. The information on the model plate is very important if you need help from your dealer or the MTD customer support department.

- Every mower has a model plate. You can locate it by standing behind the unit in the operating position and looking down at the cutting deck.

- The model plate will look like Figure 2.

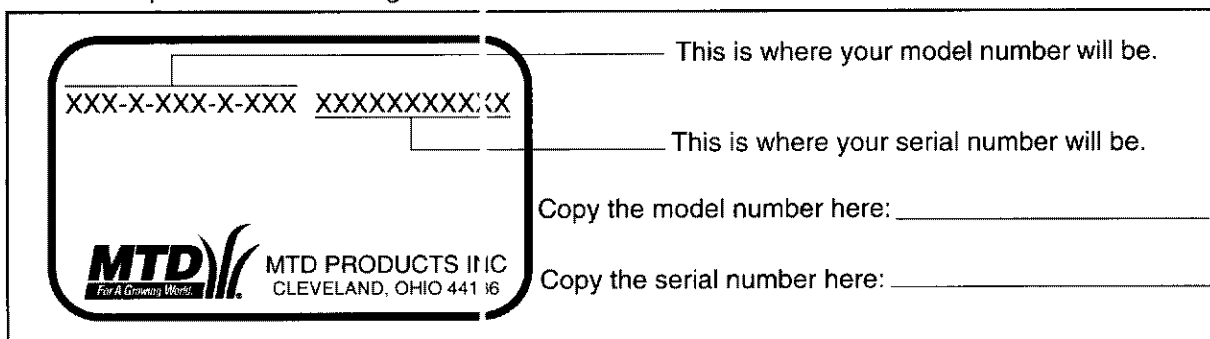

Figure 2

SECTION 4: CALLING CUSTOMER SUPPORT

If you are having difficulty assembling this product or if you have any question regarding the controls, operation or maintenance of this mower, please call the Customer Support Department. You can reach them by calling:

1-800-800-7310

Before you call, make sure that you have both your model and serial number ready. By having the model and serial number ready, you help the Customer Support Representative give you faster service. To find your units model and serial number, see SECTION 3: FINDING YOUR MODEL NUMBER.

SECTION 5: UNPACKING INSTRUCTIONS

REMOVE UNIT FROM CARTON

- See Figure 3.
- Remove staples, break glue on top flaps, or cut tape at carton end and peel along top flap to open carton.
- Remove loose parts if included with unit (i.e., owner's manual, etc.).
- Cut along dotted lines and lay carton down flat.
- Remove packing material.
- Roll or slide unit out of carton. Check carton thoroughly for loose parts.

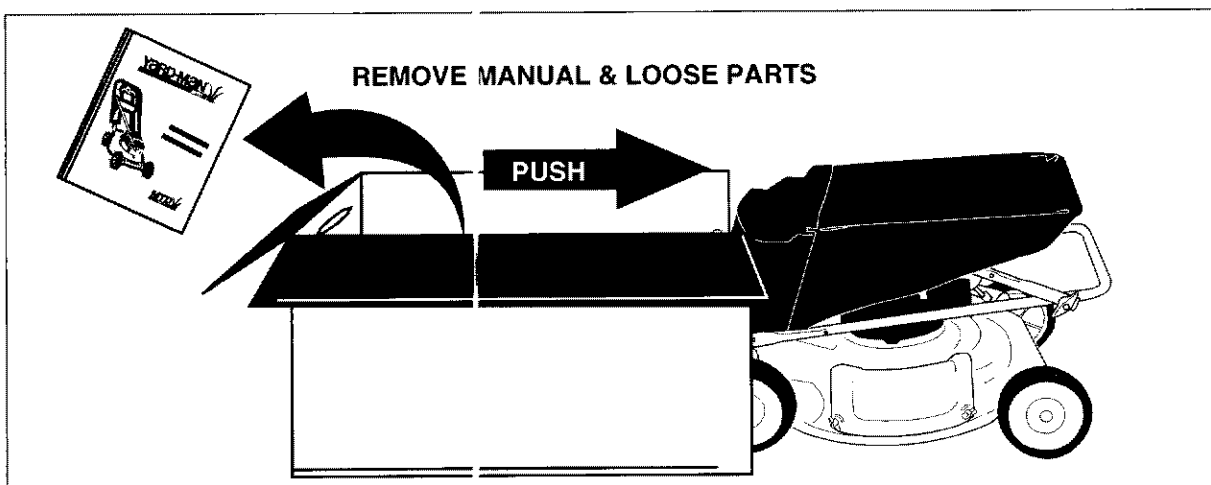

Figure 3

DISCONNECT SPARK PLUG WIRE

Before setting up your lawn mower, disconnect the spark plug wire from the spark plug, and ground it against the engine by attaching rubber boot to a bolt or metal clip to the grounding post on the engine. See Figure 4.

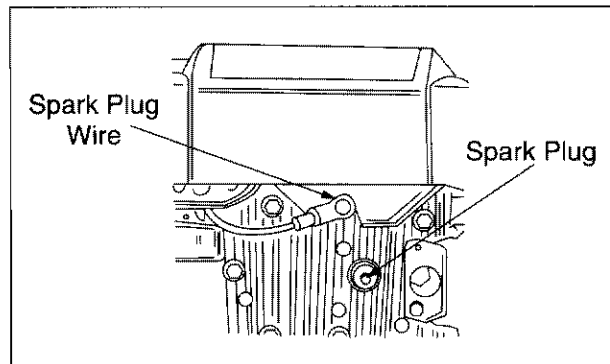

Figure 4

SECTION 6: SET-UP INSTRUCTIONS

ITEMS REQUIRED FOR ASSEMBLY

- Pair of Pliers (Not necessary, but helpful)
- Motor Oil
- Fresh Gasoline

IMPORTANT: This unit is shipped WITHOUT GASOLINE or OIL in the engine. Be certain to service engine with gasoline and oil as instructed in the separate engine manual before operating your mower.

NOTE: Reference to right or left hand side of the mower is observed from the operating position.

SET-UP YOUR LAWN MOWER

Follow steps 1 through 9 to set-up your lawn mower.

Step 1. Remove grass bag (model 970-979 only) from unit and set it out of the way.

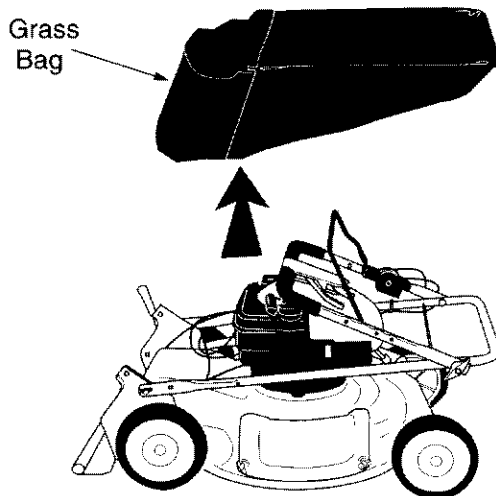

Step 2. Lift upper handle. Align it with lower handle.

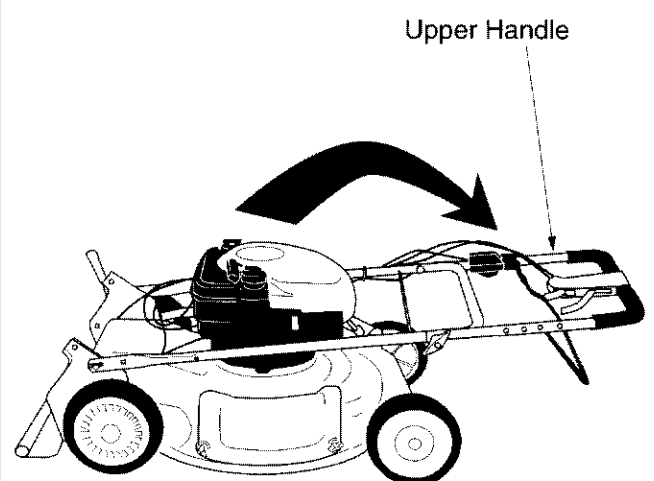

Step 3. Tighten wing nuts.

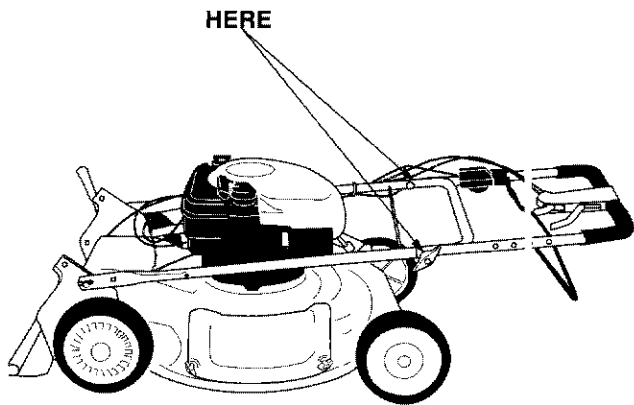

Step 4. Raise complete handle assembly until it clicks into place. Make sure not to kink the control cables.

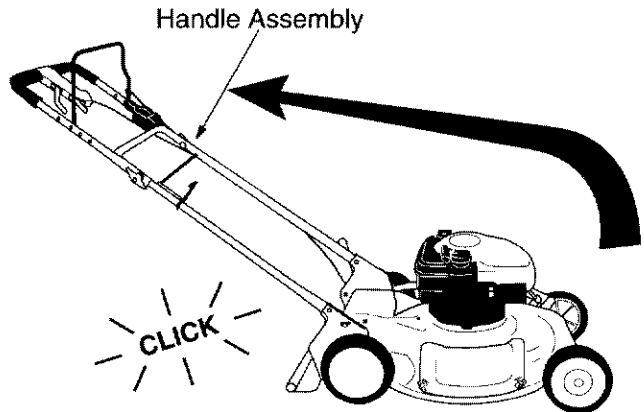

Step 5. Pinch lower handle against mounting bracket with pliers.

Step 6. Move hairpin clip from outer to inner hole on left and right handle mounting brackets.

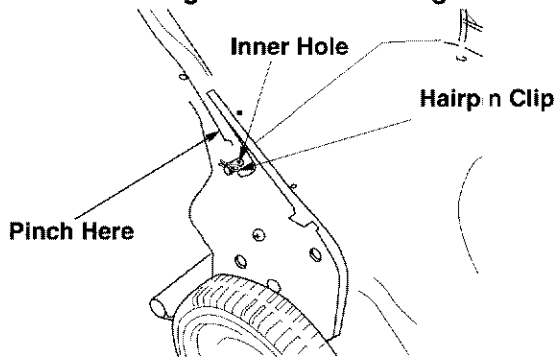

Step 7. Attach control cables to handle with pull ties found on the handle.

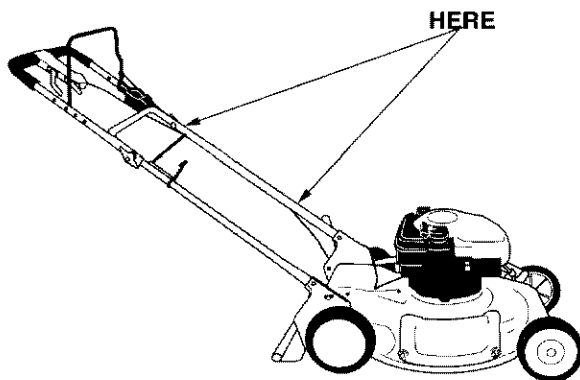

Step 8. Squeeze the blade control handle against the upper handle and pull out starter rope, slowly!

Step 9. Thread starter rope into rope guide.

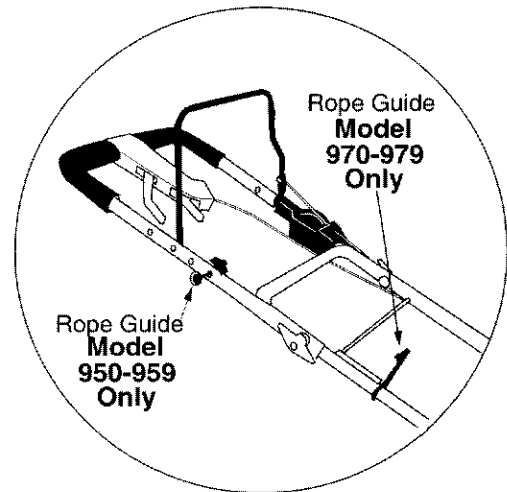
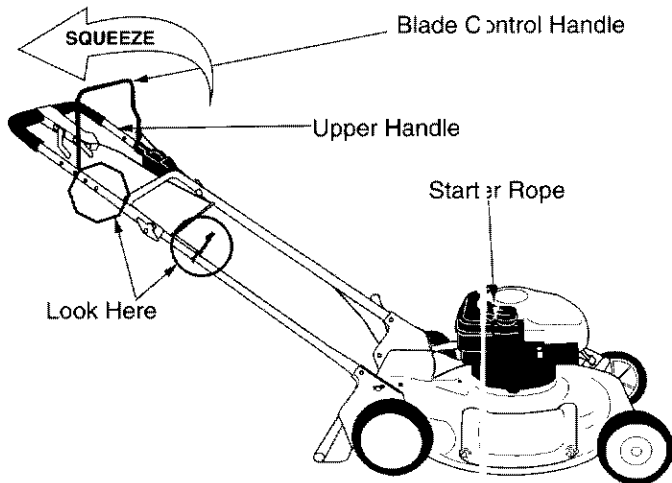

SECTION 7: CONTROLS

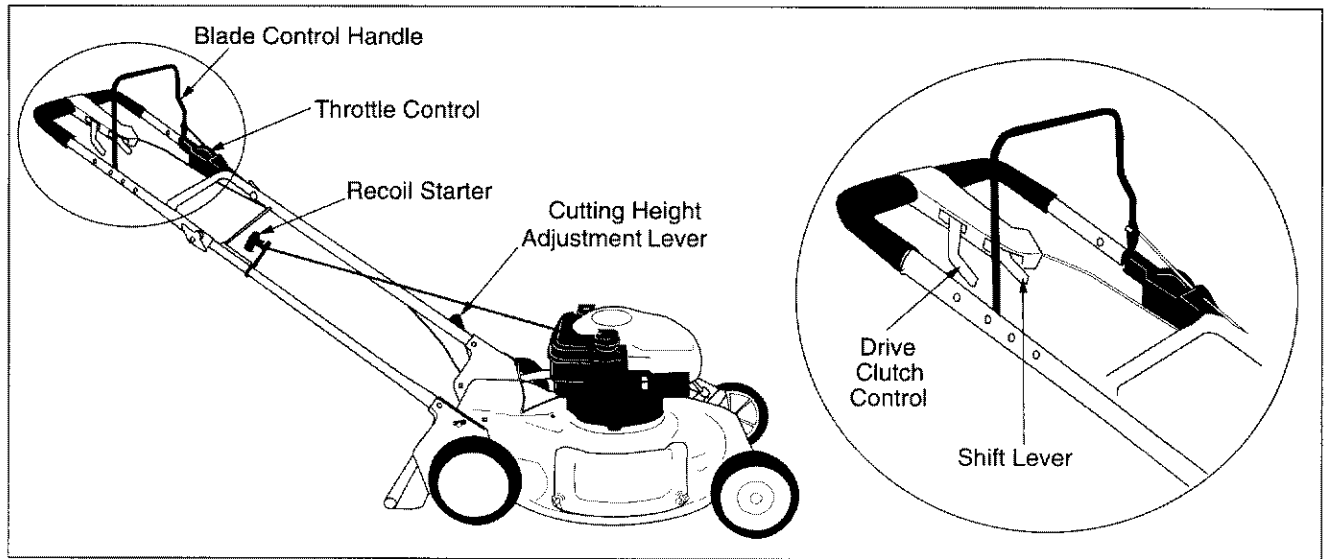

Figure 5

BLADE CONTROL HANDLE

The blade control handle is located on the upper handle of the mower. See Figure 5. The blade control handle must be depressed in order to start and operate the unit. Release the blade control handle to stop the engine and blade.



WARNING: The blade control handle is a safety device. Never attempt to bypass its operations. The blade will be rotating whenever the engine is running.

THROTTLE CONTROL

The throttle control is located on the left side of the upper handle. It is used to regulate the engine speed. See Figure 5.

- Push the throttle lever forward for fast.
- Pull the throttle lever back for slow.



WARNING: The throttle control cannot be used to stop the engine.

IGNITION SWITCH (Electric Start Unit Only)

The ignition switch is located on the left side of the handle panel. It is used for starting only. See Figure 6.

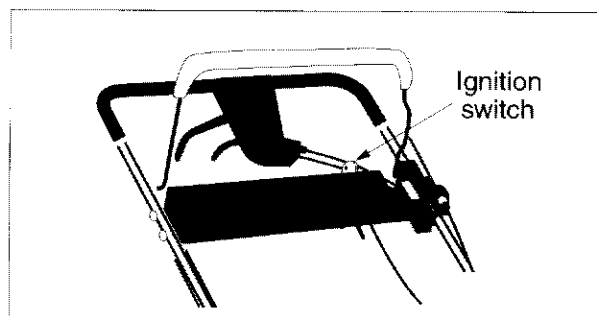

Figure 6 Electric Start Unit Only

RECOIL STARTER

The recoil starter handle is attached to the lower handle. See Figure 5. Stand behind the unit in the operating position to start the unit.

DRIVE CLUTCH CONTROL

Squeezing the drive clutch control engages the drive system. Releasing the clutch control disengages the drive system. Release the clutch control to slow down when negotiating an obstacle, making a turn or stopping.

SHIFT LEVER

The shift lever is located on the drive clutch control housing on the upper handle. See Figure 5. This lever is used to select the forward speed of the mower. When changing your speed selection, release the drive clutch control.

NOTE: Only move the shift lever when the engine is running. Changing the shift lever setting with the engine off can cause damage to the mower.

CUTTING HEIGHT ADJUSTMENT LEVER

Note: Your mower is shipped with the cutting height in the lowest position. Adjust the cutting height as follows. The cutting height adjustment lever is located above the left rear wheel. To adjust the cutting height, pull the lever out and away from the mower and then move it forward or back to select a new cutting height. See Figure 7.

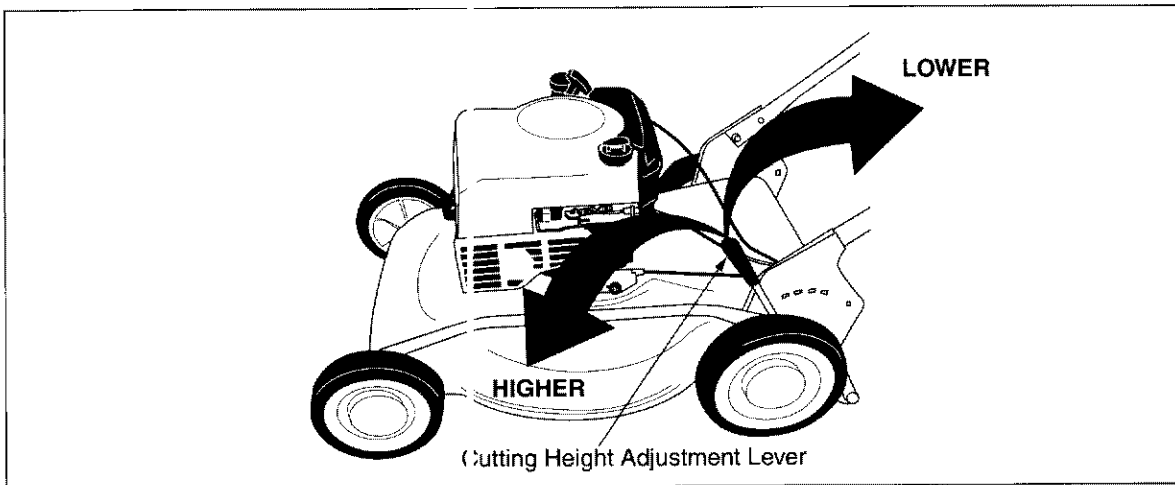

Figure 7

NOTE: For rough or uneven lawns, move the height adjustment lever to a higher position. This will help stop scalping.

ENGINE CONTROLS

See the engine manual for the location and function of the controls located on the engine.

SECTION 8: OPERATION



WARNING: Keep hands and feet away from the chute area on cutting deck. See Figure 1. The operation of any lawn mower can result in foreign objects being thrown into the eyes, which can result in severe eye damage. Always wear safety glasses or eye shields.

NOTE: For best results raise the cutting position until it is determined which height is best for your lawn. See CUTTING HEIGHT ADJUSTMENT LEVER in the CONTROLS section.

GAS AND OIL FILL-UP

Service the engine with gasoline and oil as instructed in the separate engine manual. Read all instructions carefully.



WARNING: Never fill fuel tank indoors, with engine running or until the engine has been allowed to cool for at least two minutes after running.

EACH TIME BEFORE YOU START YOUR MOWER

ELECTRIC START UNITS ONLY:



Warning: The battery contains corrosive fluid and toxic material-HANDLE WITH CARE. Keep away from children. Do not puncture disassemble, mutilate or incinerate. Explosive gasses could be vented during charging or discharging. Use in a well ventilated area, away from sources of ignition.

Charging Instructions: Charge battery for 16 hours before initial use. **DO NOT CHARGE LONGER THAN 20 HOURS.**

IMPORTANT: Use only the battery charger supplied with this mower.

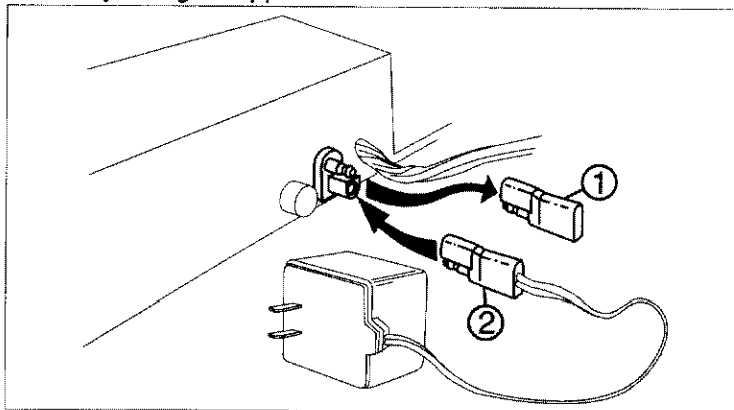

Figure 8

To charge the battery, first remove the protective cap (1) from the end of the battery pack lead. Always plug charger lead (2) into battery pack lead before inserting battery charger plug into 120 volt standard household outlet. See Figure 8.

After charging, disconnect battery charger plug from household outlet first, then disconnect charger lead from battery pack lead.



Warning: Do not remove the battery pack from the handle panel for any reason other than replacement. When replacing the battery pack, refer to the instructions in the maintenance section.

ALL UNITS:

- Attach spark plug wire to spark plug. Make certain the metal cap on the end of the spark plug wire is fastened securely over the metal tip on the spark plug.
- Check for proper drive clutch operation using the NEUTRAL ADJUSTMENT TEST.

NEUTRAL ADJUSTMENT TEST

To perform the NEUTRAL ADJUSTMENT TEST answer the following questions.

- With the drive clutch control released, push mower forward and pull it backward. Does it move freely?
- Squeeze the drive clutch control and pull the mower backward. Do the rear wheels lock (not turn)?
- Is the drive clutch control cable free of kinks or sharp bends?

If you answered “**yes**” to all three questions, your mower passed the test and you can start your mower. If you answered “**no**” to any of the three questions, you need to go through the DRIVE CLUTCH CONTROL ADJUSTMENT found in the ADJUSTMENTS section.

TO START ENGINE AND ENGAGE BLADE

- Move the throttle control lever all the way forward.
- Prime engine as instructed in the separate engine manual.
- Stand behind the unit, squeeze and hold the blade control handle against the upper handle.
- **Electric Start unit:** Turn the ignition key to the right to start the engine. Release the key after the engine starts.
- **Recoil Start:** Grasp starter handle and pull rope out slowly until engine reaches start of compression cycle (rope will pull slightly harder at this point). Let the rope rewind slowly. Pull rope with a rapid, continuous, full arm stroke. Keep a firm grip on starter handle. Return it slowly to the rope guide.
- After engine starts, move throttle control to desired engine speed. (The mower is designed to be operated at full throttle.)

NOTE: If any problems are encountered, refer to the TROUBLE SHOOTING Section of this manual.

TO STOP ENGINE AND BLADE

- Release the blade control handle to stop the engine and blade.



WARNING: The blade continues to rotate for a few seconds after the engine is shut off.

USING YOUR ROTARY MOWER

Be sure that lawn is clear of stones, sticks, wire, or other objects which could damage the lawn mower or engine. Such objects could be accidentally thrown by the mower in any direction and cause serious personal injury to the operator and others.

For the best results, do not cut wet grass because it tends to stick to the underside of the mower, preventing proper discharge of grass clippings, and could cause you to slip and fall. New grass, thick grass or wet grass may require a narrower cut.

For a healthier lawn, never cut off more than one-third of the total length of the grass. Your lawn should be cut in the fall as long as there is growth.

This mower is designed to be operated at full throttle to give you the best cut and do the most effective job of mowing or mulching.



WARNING: If you strike a foreign object, stop the engine. Remove wire from spark plug, thoroughly inspect the mower for any damage, and repair the damage before restarting and operating the mower. Extensive vibration of the mower during operation is an indication of damage. The unit should be promptly inspected and repaired.

BAGGING GRASS CLIPPINGS (Model 979 Only)

This mower can bag grass clippings. Follow steps 1 through 3 to ready the mower for bagging.

Step 1. Remove wing nuts holding mulching baffle or side discharge chute in place. Then remove plug or discharge chute.

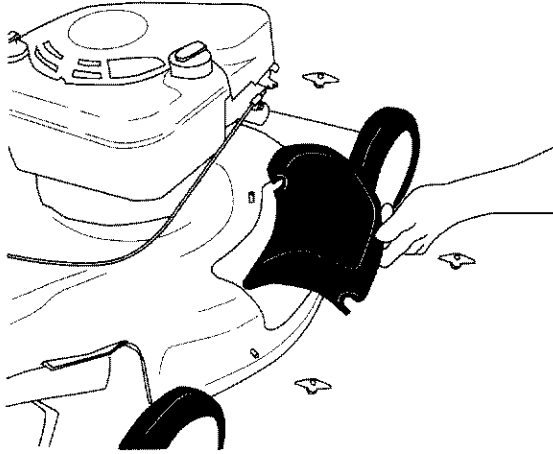

Step 2. Replace with bagging adapter. Attach using wing nuts. Be sure that inner lip of attachment goes under the edge of the deck.

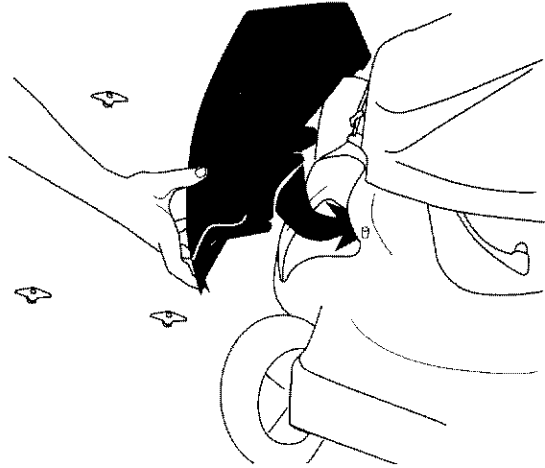

Step 3. Lift flap and slide bag onto adapter.

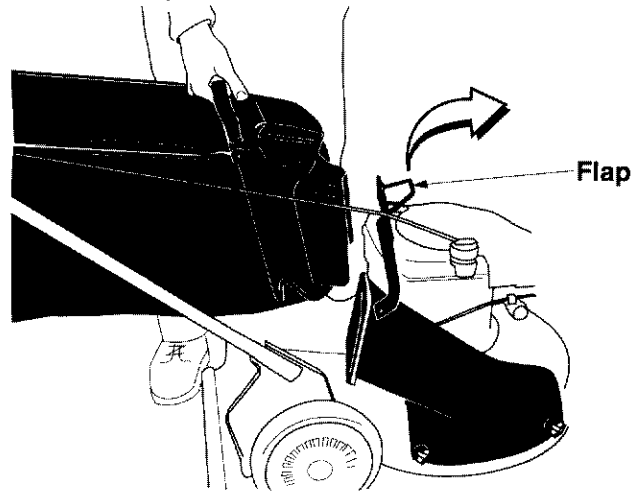

Bagging adaptor



Mulching baffle



Side discharge chute

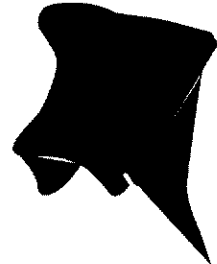

EMPTYING YOUR GRASS BAG

Lift grassbag from the bagging adaptor using the lower handle. While holding the lower handle lift up the rear section of the grassbag. The bag will open and the grass clippings will fall out. See Figure 9. When replacing your grassbag be sure the top of the bag rests on the wire support between the handles.

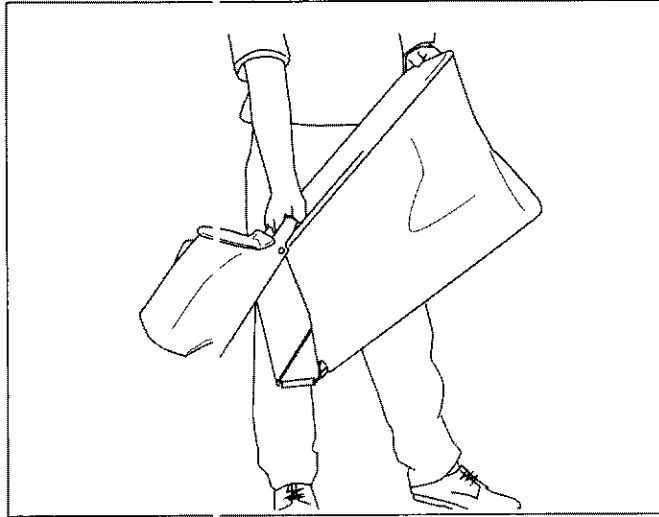
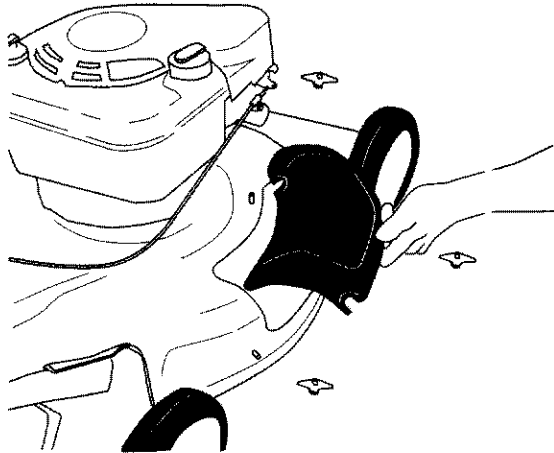

Figure 9

SIDE DISCHARGE GRASS CLIPPINGS

This mower can also side discharge grass clippings. Follow steps 1 and 2 to ready this mower for side discharge operation.

Step 1. Remove mulching baffle or grass bag adaptor.



Step 2. Attach discharge chute with wing nuts.

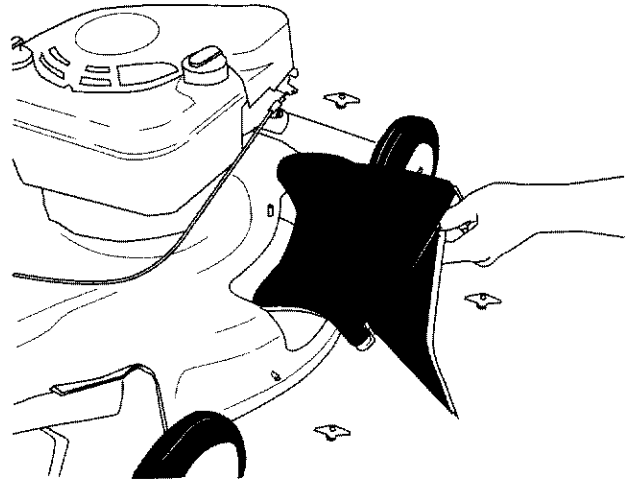

SECTION 9: ADJUSTMENTS



WARNING: Do not at any time make any adjustment to lawn mower without first stopping engine and disconnecting spark plug wire.

HANDLE HEIGHT ADJUSTMENT

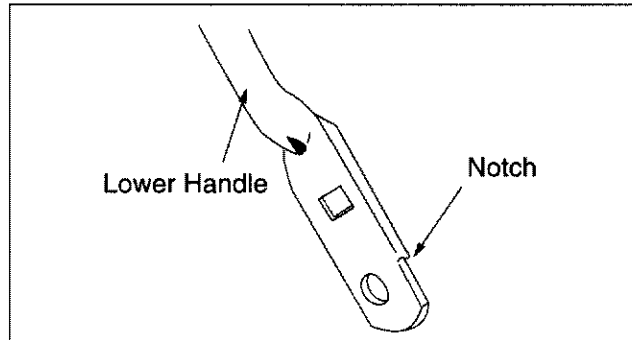

Figure 10

Your mower is shipped with the handle in the higher height position. To lower handle height, proceed as follows:

- Remove the starter rope from the rope guide.
- Remove the upper handle by removing the hand knobs and carriage bolts. Lay the upper handle out of the way, being careful not to bend or kink the cables.
- Remove the hairpin clips from the weld pins on the handle brackets. Press out on the legs of the lower handle. Remove lower handle from the mower.
- Turn lower handle around so the notch on the bottom of the lower handle is facing forward. See Figure 10. Reassemble, placing the bottom holes in the handle over the weld pins in the handle mounting bracket.
- Reassemble the upper handle to the lower handle.
- Place the hairpin clips in the inner holes in the weld pins and attach the starter rope as instructed in the Set-Up Instructions.

THROTTLE CONTROL ADJUSTMENT

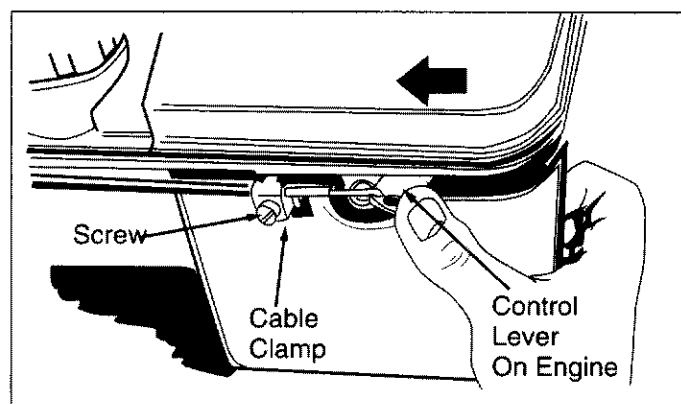

Figure 11

If the throttle control requires adjustment or if it has been replaced, adjust the throttle control as follows.

- Remove the screw shown in Figure 11. Remove the cable clamp from the cable.
- Push the throttle control lever on the handle all the way forward as far as it will go, then back it off one "click". Make certain the throttle control lever remains in this position.
- Push the control lever on the engine as far toward the rear of the engine as it will go. Secure the cable in this position with the cable clamp and screw.

DRIVE CLUTCH CONTROL ADJUSTMENT

The drive clutch control adjustment wheel is located in the drive clutch control handle housing and is used to tighten or loosen the drive belt. You will have to adjust the drive clutch control if any of the following happens:

- The mower does not propel itself with the drive clutch engaged.
- The mower's drive wheels hesitate with the drive clutch engaged.

To resolve the above problems, rotate the adjustment wheel with your fingers. Clockwise to tighten the cable and counter-clockwise to loosen the cable. See Figure 12.

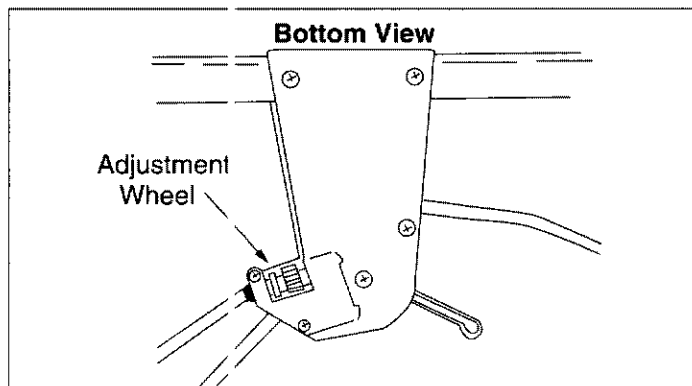

Figure 12

Note: For some people the drive clutch handle may not be in a comfortable position. You can adjust the handle out by tightening the adjustment wheel.

Follow engine manual for lubrication instructions.

SHIFT LEVER CABLE ADJUSTMENT

Periodic adjustment of the six speed shift cable may be required due to normal wear on the cable. Adjustment is needed if all six speeds do not work.

The adjustable cable bracket is located on the left side of the mower, beside the engine. Follow steps 1 through 7 to adjust the shift lever.

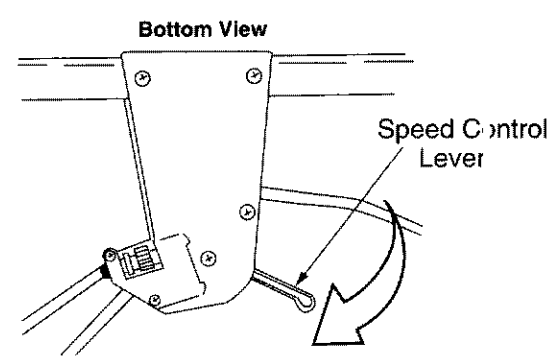
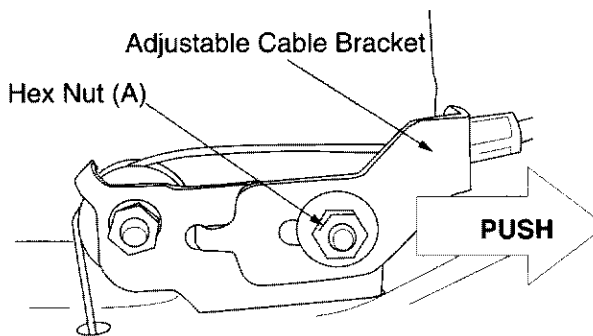
 <p>Bottom View</p> <p>Speed Control Lever</p> <p>Step 1. Start engine.</p> <p>Step 2. Place speed control in the sixth speed position.</p> <p>Step 3. Stop engine.</p> <p>Step 4. Disconnect spark plug wire and ground it.</p>	 <p>Adjustable Cable Bracket</p> <p>Hex Nut (A)</p> <p>PUSH</p> <p>Step 5. Loosen hex nut (A) which secures the adjustable cable bracket.</p> <p>Step 6. Push back on the adjustable cable bracket.</p> <p>Step 7. Tighten hex nut (A).</p>
--	---

SECTION 10: MAINTENANCE



WARNING: Be sure to disconnect and ground the spark plug wire before performing any repairs or maintenance.

NOTE: When tipping the unit, empty the fuel tank and keep engine, spark plug side up. Never tip the mower more than 90 degrees and do not leave the mower tipped for any length of time. Oil can drain into the upper part of the engine causing a starting problem.

ENGINE

Refer to the separate engine manual for all engine maintenance instructions.

- Maintain engine oil as instructed in the separate engine manual packed with your unit. Read and follow instructions carefully.
- Service air cleaner every 25 hours under normal conditions. Clean every few hours under extremely dusty conditions. Poor engine performance and flooding usually indicates that the air cleaner should be serviced. To service the air cleaner, refer to the separate engine manual packed with your unit.
- The spark plug should be cleaned and the gap reset once a season. Spark plug replacement is recommended at the start of each mowing season; check engine manual for correct plug type and gap specifications.
- Clean the engine regularly with a cloth or brush. Keep the cooling system (blower housing area) clean to permit proper air circulation which is essential to engine performance and life. Be certain to remove all grass, dirt and combustible debris from muffler area.

DECK

The underside of the mower deck should be cleaned after each use to prevent a buildup of grass clippings, leaves, dirt or other matter. If this debris is allowed to accumulate, it will invite rust and corrosion, and may prevent proper mulching, discharge or bagging.

The deck may be cleaned by tilting the mower and scraping clean with a suitable tool (make certain the spark plug wire is disconnected).

ELECTRIC START UNITS ONLY:

BATTERY PACK REPLACEMENT

Remove the battery pack from the handle panel for replacement only. Do not separate the batteries for any reason. Dispose of batteries properly.



WARNING: Batteries contain sulfuric acid which may cause burns. Do not short circuit or mutilate in any way. Do not put batteries in fire. They may burst or release toxic materials.

When replacing battery pack in handle panel, battery pack must be positioned with the positive terminal to the right hand side and the negative terminal to the left hand side of panel. Replacing the battery pack incorrectly will cause serious damage.

The positive lead on the wire harness has the smaller connector. Connect the positive lead to the positive side of the battery pack, then connect the negative side.

IN-LINE FUSE

The unit is equipped with an in-line fuse. If unit fails to start, check the fuse inside the battery cover by turning the end of the fuse holder and removing from the battery cover. Replace with standard automotive 7-1/2 amp fuse.

STORAGE OF THE BATTERY

The battery must be stored with a full charge. A discharged battery will freeze.

IMPORTANT: All batteries discharge during storage. Recharge battery every two months and before returning to service. Refer to charging instructions in OPERATION section.

CUTTING BLADE REMOVAL, REPLACEMENT AND SHARPENING

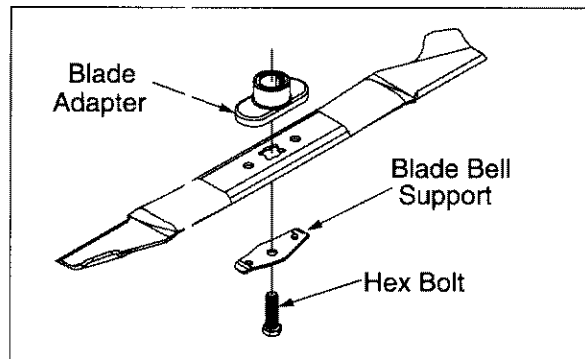

Figure 13

- When removing the cutting blade for sharpening or replacement, protect hands with heavy gloves or a rag before grabbing the blade.
- Remove the bolt and blade bell support which hold the blade and adapter to the engine crankshaft.
- Remove the blade and adapter from the crankshaft.



WARNING: Periodically inspect the blade adapter for cracks, especially if you strike a foreign object. Replace when necessary.

When sharpening the blade, follow the original angle of grind as a guide. It is extremely important that each cutting edge receives an equal amount of grinding to prevent an unbalanced blade. An unbalanced blade will cause excessive vibration when rotating at high speeds. It may cause damage to the mower, and it could break causing personal injury.

The blade can be tested by balancing it on a round shaft screwdriver. Remove metal from the heavy side until it balances evenly. It is recommended that the blade always be removed from the adapter for the when testing for balance.

Before reinstalling the blade and the blade adapter to the unit, lubricate the engine crankshaft and the inner surface of the blade adapter with light oil.

- Be sure to install the blade with the side of the blade marked "Bottom" (or with part number) facing the ground when the mower is in the operating position.
- Slide blade adapter onto engine crankshaft.
- Place blade on adapter. Be certain the blade is aligned with and seated onto the blade adapter flanges.
- Place blade bell support on blade. Make sure the notches on the blade bell support are aligned with the small holes in the blade.
- Replace hex bolt.
- Tighten hex bolt to torque: 450 in. lbs. min., 600 in. lbs. max.

NOTE: To ensure safe operation of your unit, the blade bolt must be checked periodically for correct torque.

DRIVE BELT REMOVAL AND REPLACEMENT

Step 1. Disconnect the spark plug wire and ground it against the engine.

Step 2. Drain the fuel tank or place a piece of plastic beneath the cap to prevent gasoline leakage.

Step 3. Place shift lever in the first position.

Step 4. Tip the mower on its side. Block securely.

Step 5. Remove the center bolt which secures the blade to the crankshaft. Remove the blade, and the blade adapter, wave washer, and spacer. Refer to Cutting Blade Removal, Replacement and Sharpening in the Maintenance Section.

Step 6. Move rear height adjuster to the sixth position.

Step 9. Remove the hex bolt holding the transmission to the mower housing.

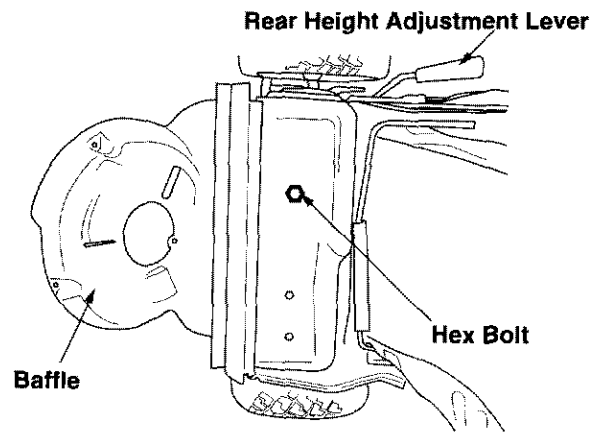

Step 7. Using a 3/8" socket, remove three hex screws holding the baffle to the deck.

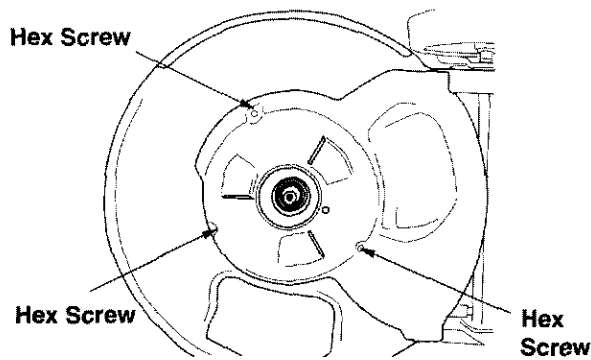

Step 10. Tilt the transmission forward and loosen the idler pulley bolt and locknut 1/2 turn using two 7/16" wrenches.

Step 11. Using a pair of pliers, pull back and rotate belt keeper bracket from the slot on idler pulley.

Step 12. Slide the belt out from between the Belt Keeper Bracket and the idler pulley.

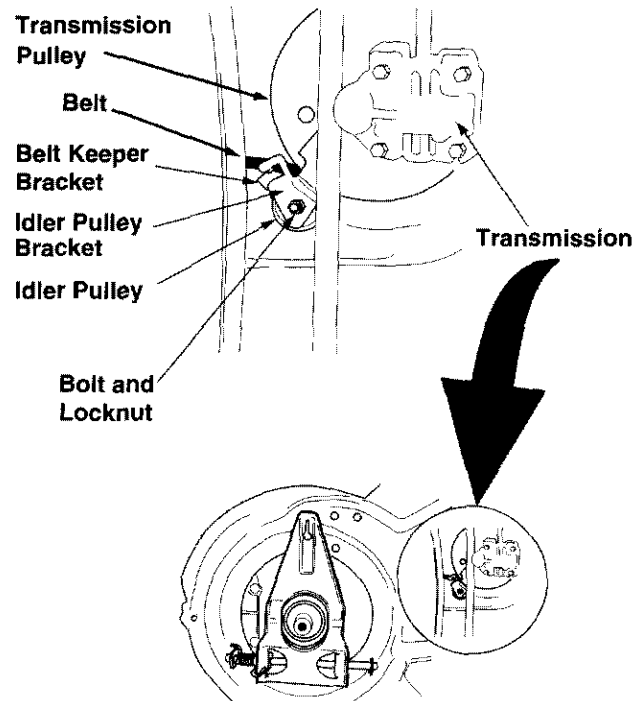

Step 8. Pivot baffle towards the rear of the mower.

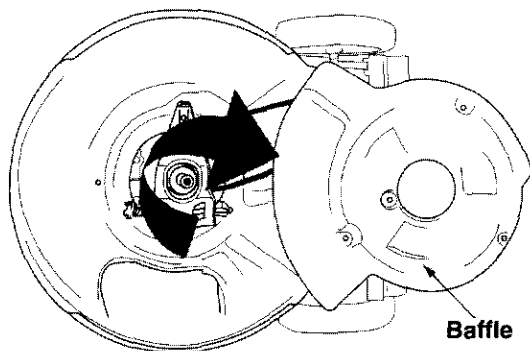

Step 13. Squeeze the belt together and push belt forward. Press the control arm inward towards the deck and remove the six speed cable from the slot.

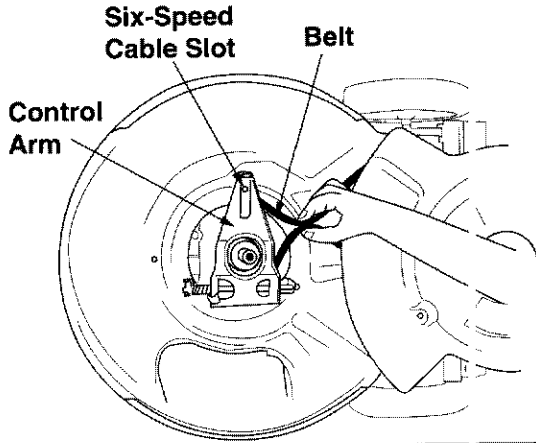

Step 14. Pivot the control arm down away from the pulley and belt.

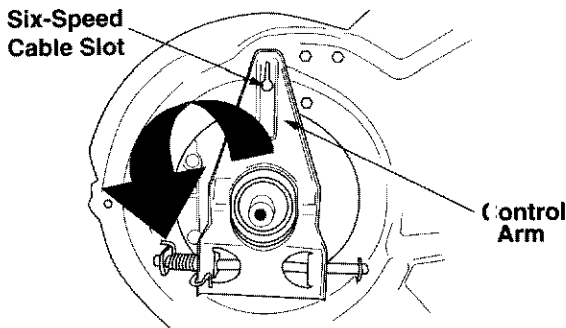

Step 15. Lift off the lower pulley assembly and remove the old belt from around the crankshaft.

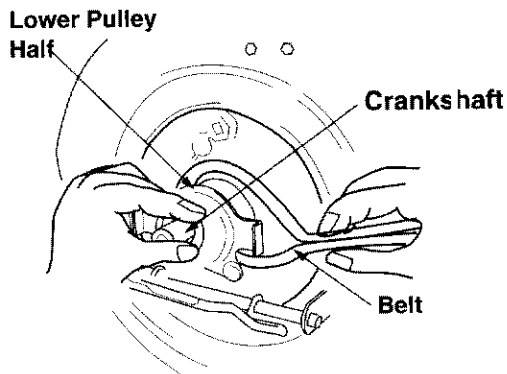

Step 16. Place the new belt over the transmission pulley. Start the belt in pulley groove and rotate pulley until belt is seated in transmission pulley.

Step 17. Place belt between idler pulley and the belt keeper bracket.

Step 18. Using pliers, rotate the belt keeper bracket so that it snaps into slot on the idler bracket.

Step 19. Tighten the Idler Pulley bolt and Locknut 1/2 turn using two 7/16" wrenches.

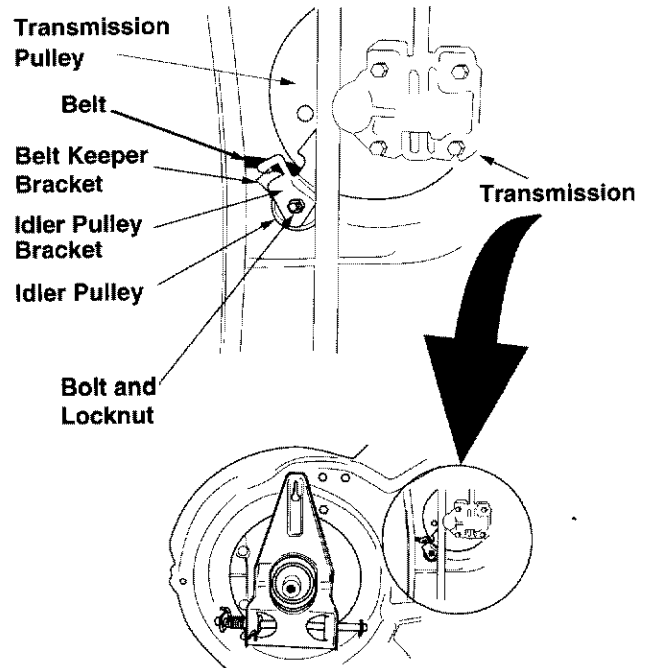

Step 20. Place belt between the two pulley halves on the crankshaft. Make sure to route the belt inside the belt guard pin.

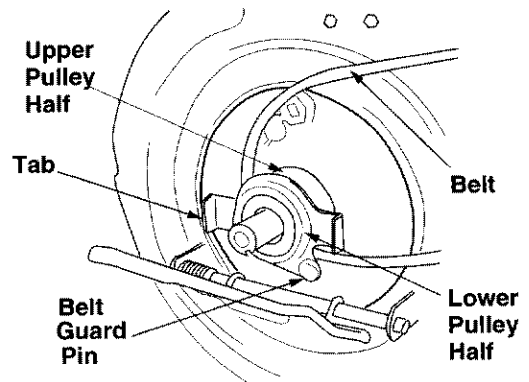

IMPORTANT: When replacing the belt, do not disassemble the lower pulley assembly.

Step 21. Pinch belt together so that it is not in the pulley groove, and the lower pulley can be pushed towards the engine.

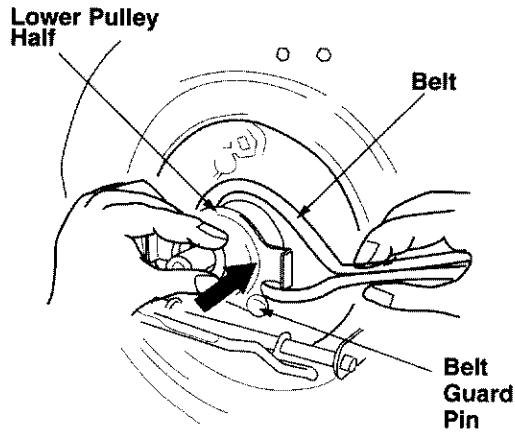

Step 22. Pivot the control arm back to its original position and reinstall the six-speed cable into the slot.

Step 23. Check and make sure the belt is routed inside the pulley halves and the belt guard pin.

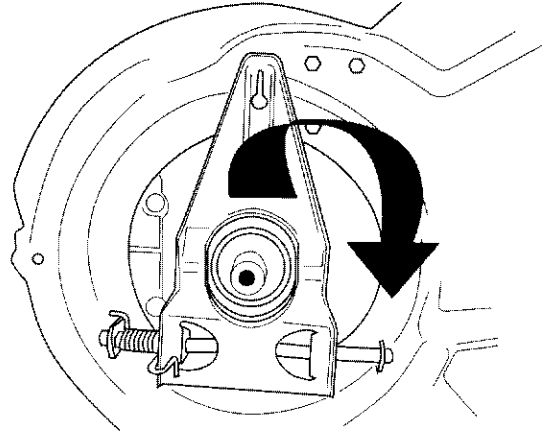

Step 24. Reinstall the bolt securing transmission to rear mower housing.

Step 25. Pivot the baffle back to its original position and secure with three hex screws earlier removed. You will need a 3/8" socket for these screws.

Step 26. Lightly lubricate the inside of the blade adapter and reinstall spacer, wave washer, blade adapter assembly and the blade in the correct order.

Step 27. Tighten the hex bolt to secure the blade. Follow recommended torque which is 450-600 in. lbs.

SECTION 11: LUBRICATION



WARNING: Always stop engine and disconnect spark plug wire before cleaning, lubricating or doing any kind of work on the lawn mower.

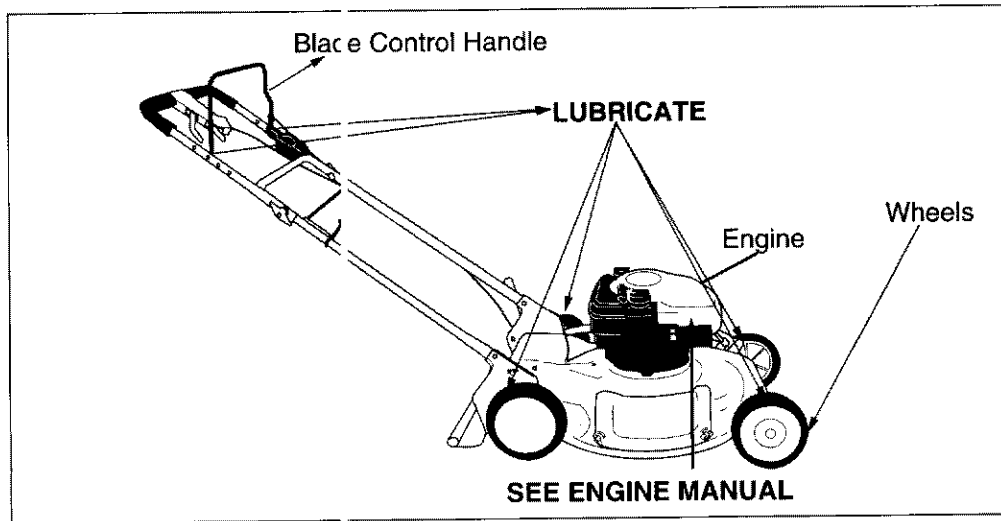

Figure 14

Blade Control: Lubricate the pivot points on the blade control handle and the brake cable at least once a season with light oil. See Figure 14. The blade control must operate freely in both directions.

Wheels: Lubricate the wheels at least once a season with light oil (or engine oil). Also, if the wheels are removed for any reason, lubricate the surface of the axle bolt and the inner surface of the wheel with light oil. See Figure 14.

Engine: Follow engine manual for lubrication instructions.

SECTION 12: OFF-SEASON STORAGE

The following steps should be taken to prepare lawn mower for storage.

- Clean and lubricate mower thoroughly as described in the lubrication instructions.
- Refer to engine manual for correct engine storage instructions.
- Follow battery storage instructions on page 17 (Electric Start Units Only).
- Coat mower's cutting blade with chassis grease to prevent rusting.
- Store mower in a dry, clean area. Do not store next to corrosive materials, such as fertilizer.

NOTE: When storing any type of power equipment in a poorly ventilated or metal storage shed, care should be taken to rust-proof the equipment. Using a light oil or silicone, coat the equipment, especially cables and all moving parts.

SECTION 13: TROUBLE SHOOTING GUIDE

Trouble	Possible Cause(s)	Corrective Action
Engine fails to start	Blade control handle disengaged. Spark plug wire disconnected. Throttle control lever not in correct starting position. Fuel tank empty, or stale fuel. Blocked fuel line. Faulty spark plug. Engine flooded.	Engage blade control handle. Connect wire to spark plug. Move throttle lever to FAST or START position. Fill tank with clean, fresh gasoline. Clean fuel line. Clean, adjust gap or replace. Crank engine with throttle in FAST position.
Engine runs erratic	Unit running in START position. Spark plug wire loose. Blocked fuel line or stale fuel. Vent in gas cap plugged. Water or dirt in fuel system. Dirty air cleaner. Carburetor out of adjustment.	Move throttle lever to FAST position. Connect and tighten spark plug wire. Clean fuel line; fill tank with clean, fresh gasoline. Clear vent. Drain fuel tank. Refill with fresh fuel. Clean air cleaner. Adjust carburetor.
Engine overheats	Engine oil level low. Air flow restricted. Carburetor not adjusted properly.	Fill crankcase with proper oil. Remove blower housing and clean. Adjust carburetor.
Occasional skip (hesitates) at high speed	Spark plug gap too close.	Adjust gap to .030".
Idles poorly	Spark plug fouled, faulty or gap too wide. Carburetor improperly adjusted. Dirty air cleaner.	Reset gap to .030" or replace spark plug. Adjust carburetor. Clean air cleaner.
Excessive vibration	Cutting blade loose or unbalanced. Bent cutting blade.	Tighten blade and adapter. Balance blade. Replace blade.
Mower will not mulch grass	Engine speed too low. Wet grass. Excessively high grass. Dull blade.	Set throttle between 3/4 and full throttle. Do not mow when grass is wet; wait until later to cut. Mow once at a high cutting height, then mow again at desired height or make a narrower cutting swath (1/2 width). Sharpen or replace blade.
Uneven cut	Wheels not positioned correctly. Dull blade.	Place all four wheels in same height position. Sharpen or replace blade.

Refer to separate engine manual packed with your mower for more engine related information.

NOTE: For repairs beyond the minor adjustments listed above, contact your nearest authorized service dealer or call 1-800-800-7310 for the Customer Support Center.

Models 959/979/E979

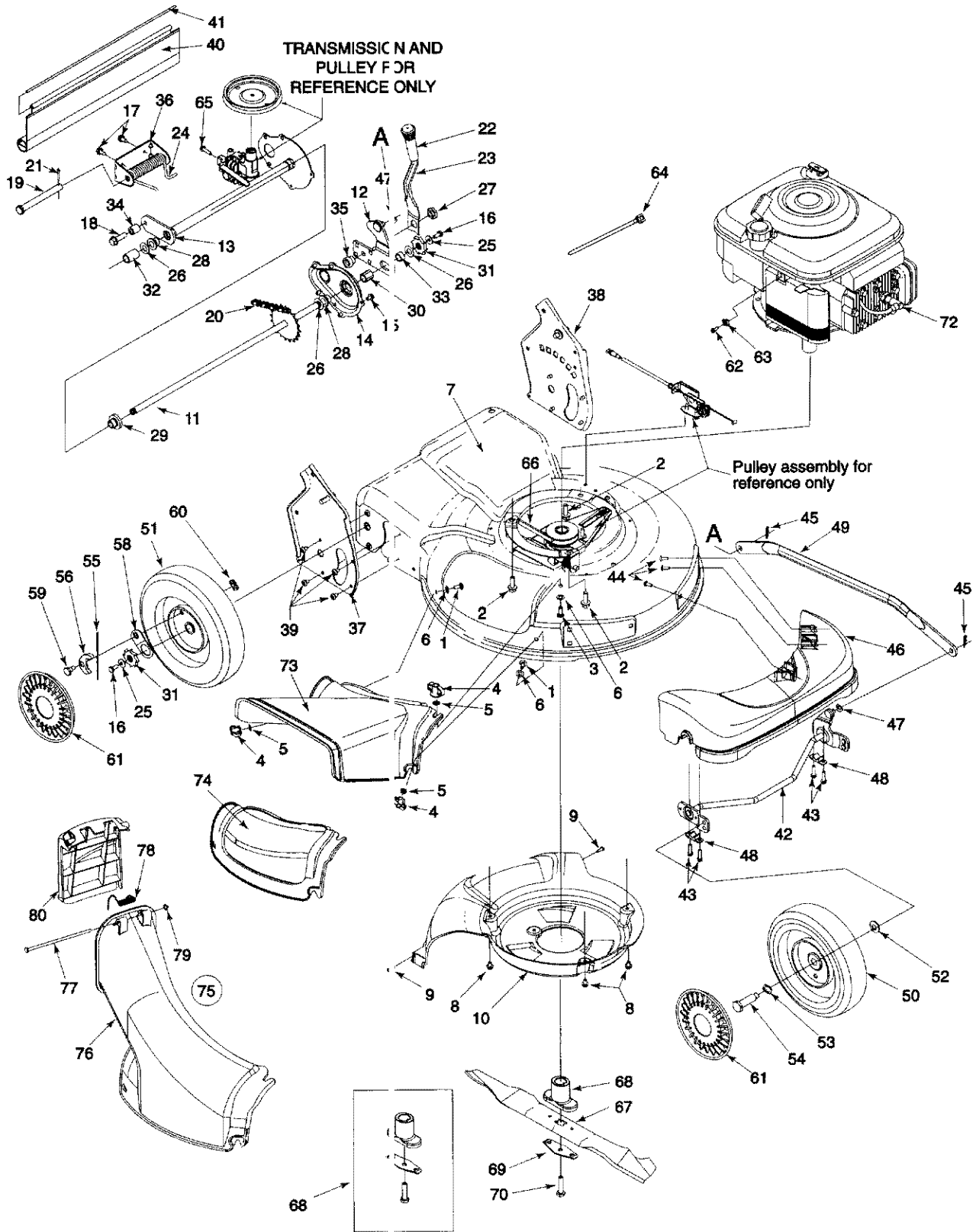

Models 959/979/E979

Ref. No.	Part No.	Description	Ref. No.	Part No.	Description
1	710-0134	Scr. Carr. 1/4-20 x .62	40	731-1901 N	Trail Shield
2	710-0654A	Scr. TT:3/8-18:1.00	41	732-0842 N	Trail Shield Wire
3	710-0703	Scr. 1/4-20 x .750	42	611-0064-0665 N	Fr. Axle Ass'y.
4	712-0397	Wing Nut 1/4-20	43	710-1241	Hx Scr. Wash Hd. Hi.-Lo.
5	723-0233	Nut, Push .25 I.D. x .50 O.D.	44	710-1242	Scr. Torx, Truss Hi.-Lo.
6	736-0204	Wash. Fl. .334 I.D.x .62 x.03	45	714-0104	Cotter Pin .072 x 1.12 Lg.
7	782-0046-0665 N	Deck - 21"	46	731-1829 N	Fr. Axle Cover, Yellow
8	710-0653	Scr. TT. 1/4-20 x .375	47	736-0286	Bowed Washer
9	710-1220	Scr. HL. 1/2-14 x .750	48	741-0492A	Bush. Block .505 Dia. x .62
10	731-1828 N	Baffle	49	782-0565-0665 N	Control Arm
11	638-0012 N	Rear Axle Ass'y	50	734-1818 N	Wheel 8 x 2 Link, Yellow
12	682-0531 N	Pivot Arm Ass'y	51	734-1836 N	Wheel 9 x 2 Link Yellow, Slv.
13	682-7526 N	Trans. Axle Ass'y	52	736-0105	Spr. Wash. .401 x .870 x .063
14	682-7528 N	Chain Cover Ass'y	53	736-0504	Wave Wash .510 x .750 x .017
15	710-0653	Scr. TT 1/4-20 x .375	54	738-0102	Shldr Scr .498 x 1.445 x3/8-16
16	710-0751	Cap Screw HH 1/4-20 x .620	55	10622B	Spring, Ratchet, Plastic
17	710-0896	Scr. AB 1/4-14 x .825	56	748-0381	Pawl - R.H.
18	710-1315	Scr. 3/8 116 x .25	57	748-0188B	Pawl - L.H. (Not Illustrated)
19	711-0835	Clevis Pin .50 Dia. x 4.82 Lg.	58	16855	Ratchet Pawl Plate
20	713-0453 N	Chain-Endls. #48 .500P x 24L	59	738-0137A	Scr. Shld. .340 x .285
21	714-0474	Cotter Pin .125O.D. x .75	60	712-0414	Top Lock Tab Weld Nut 1/4-20
22	720-0223	Grip	61	731-1426	Hubcap -Yellow
23	732-0803 N	Spring Lever	62	710-1237	Screw .620 Hx. Slit. Wsh.
24	732-0832 N	Torsion Spring	63	751B213146	Casing Clamp, Throttle
25	736-0270	Bell Wash. .285 x .75 x .082	64	725-0157	Cable Tie
26	736-0369	Fl. Wash..508 I.D. 1.000 x.020	65	710-0604	Hex Scr. 5/16-18
27	738-0529	Nut Shld. .825 Dia. x .165 Lg.	66	754-0460 N	Belt
28	741-0324	Hx.Flg. Brg..506 I.D. x .590 L.	67	742-0741	21" Mulching Blade
29	741-0522	Hx.Flg. Brg. .506 I.D. x.715 L.	68	753-0609	Blade Adapter Kit
30	741-0978 N	Hx. Slv. Brg..504 I.D. x .830 L.	69	736-0524A	Blade Bell Suport
31	748-0318	Wheel Ratchet	70	710-1257	Hex Bolt 3/8-24x2.5"Lg.
32	750-0151	Spa. .550 I.D. x /750 O.D.	72	735-0639	Spark Plug Insulator
33	750-0515	Spa. .51 .D. x .70 O.D. x 38 L.	73	731-1832 N	Side Discharge Chute
34	750-0807	Spa. .385 x .624 x .700	74	731-1833 N	Mulch Cover
35	750-1056 N	Shld. Spa. .385 I.D. X .715 Lg.	75	631-0066 N	Chute Ass'y ††
36	782-0568 N	Brkt. - Ht. Adj. Spring	76	731-1713 N	Discharge Chute ††
37	682-3052-0665 N	Handle Brkt. Ass'y. R.H.	77	747-0965 N	Pivot Rod ††
38	682-3053-0665 N	Handle Brkt. Ass'y. L.H.	78	732-0819 N	Torsion Spring ††
39	710-1348	Scr. AB 1/4-14 x .500	79	726-0111	Push Cap ††
			80	731-1874 N	Chute Door ††

†† Model 979 only

Models 959/979

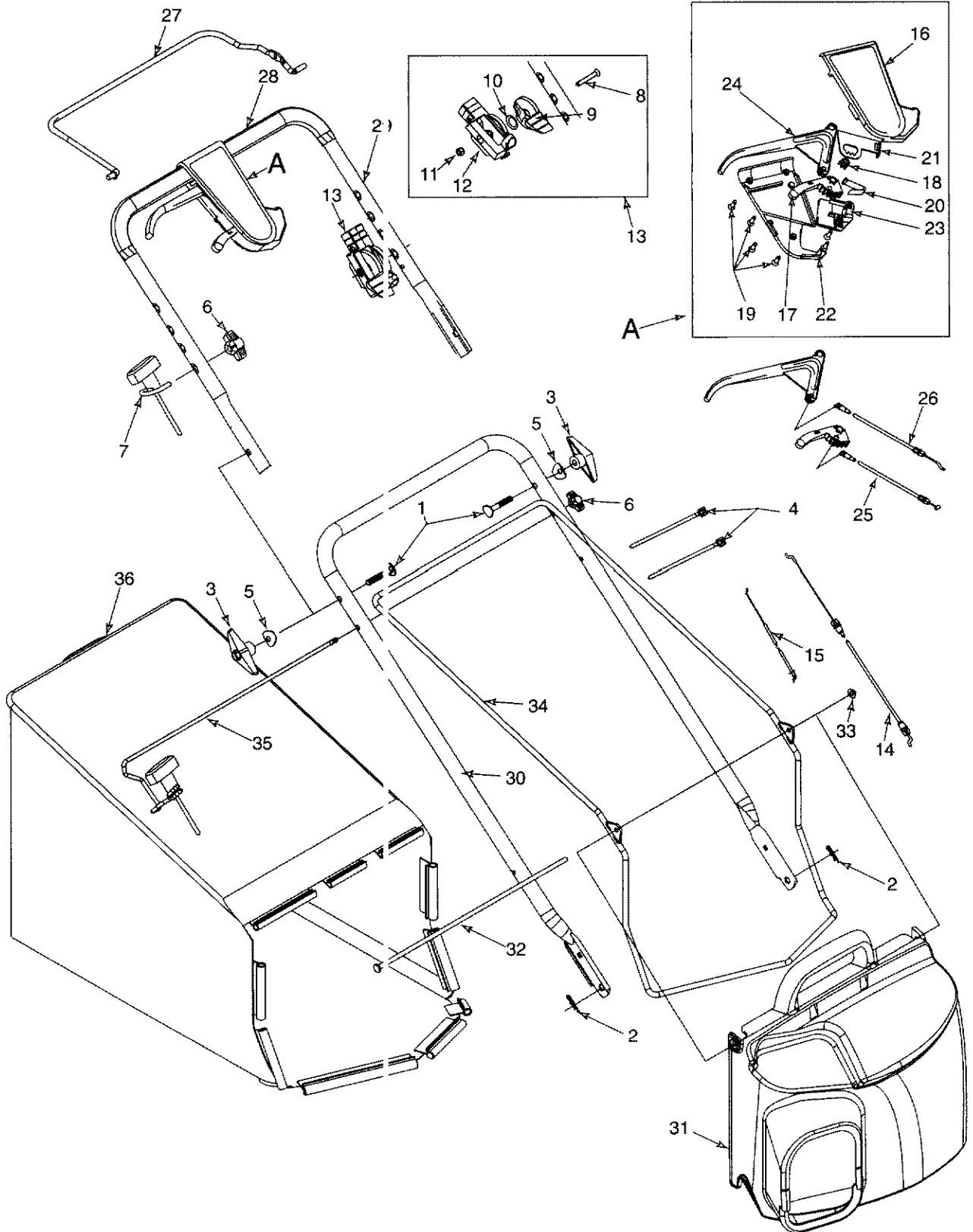

Models 959/979

Ref. No.	Part No.	Description	Ref. No.	Part No.	Description
1	710-1174	Bolt Cur. Carr. 5/16-18 x 2.0	19	710-0841	C Sunk Tap Screw #10 x .75 L
2	714-0104	Cotter Pin .072 x 1.12 Lg.	20	732-0627	Shift Lever Spring
3	720-0241	Knob Ass'y Wingnut 5/16-18	21	16864	6 Spd. Rack Cable Brkt.
4	726-0240	Strap 4.3 Lg.	22	731-0905	Lower Control Housing
5	736-0451	Wash. Sad. .320 ID x.830 OD	23	731-0906	Cable Mounting Cap
6	720-0279	Knob Handle ERS - 1/4-20	24	731-0620	Control Lever
7	710-1205	Rope Guide Eyebolt †	25	746-0939	N 6 Spd. Cable
8	710-0605	Screw 1/4-20 x 1.81	26	746-0710A	S.P. Cable
9	746-0876	Throttle Lever	27	747-0824	Control Handle
10	736-0501	Spring Wash.Curved	28	720-0294	Foam Grip (2 Reqd.)
11	712-0324	Nut 1/4-20 Top locknut Insert	29	749-0439B	Upper Handle
12	646-0875	Housing, Throttle	30	749-0907	Lower Handle
13	811-00303	Throttle Control - (Includes 8,9,10,11 & 12)	31	631-0071	N Grassbag Cover w/Label ††
14	746-0557	Control Cable 47" Lg.	32	747-0939	N Pivot Rod ††
15	746-0841	Cable Throttle 60" Lg.	33	726-0106	Cap Nut ††
16	731-0904	Upper Control Housing	34	747-0937	N Frame - Grassbag ††
17	731-0924	6 Speed Shift Lever	35	747-0940	N Rod, Support ††
18	713-0397	Gear Insert	36	664-0074	N Grassbag ††

† For model 959 only

†† For model 979 onl

Labels

Ref No.	Part No.	Description	Ref No.	Part No.	Description
N/I	777-1595C	N Danger - Rt. Rear	N/I	777-4626	N YM 6/21 Label †
N/I	777-0870	Danger - Side Discharge	N/I	777-4627	N YM 6/21 Label ††
N/I	777-5270	N Warning - Above Deck Opening	N/I	777-4628	N YM 6/21 Label ‡
N/I	777-1104	Drive Label	N/I	777-5645	N Ht. Adjuster Label
N/I	777-8627	Drive Label ‡	N/I	777-1183A	Model No. Label
N/I	777-0148	Throttle Label	N/I	777-3541	Trans. Drive Label
N/I	777-4466	YM Bubble Crest	N/I	777-1105	N Start Instructions - on Battery Pack ‡
N/I	777-4569	N Wheel Cover Label	N/I	777-4629	N YM Electric Start ‡

† For model 959 only

†† For model 979 only

‡ For model E979 only

Model E979

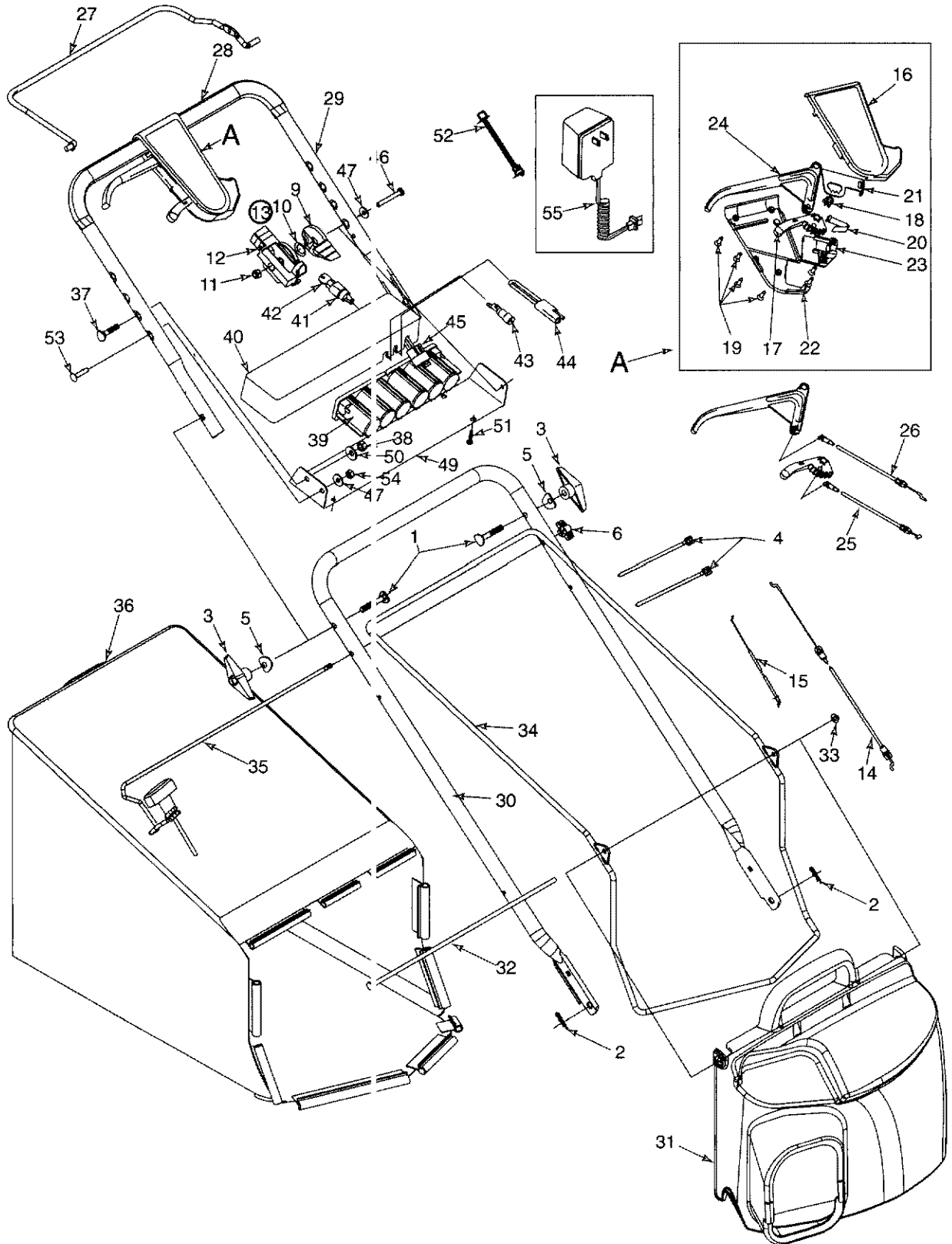

Model E979

Ref. No.	Part No.	Description	Ref. No.	Part No.	Description
1	710-1174	Bolt Cur. Carr. 5/16-18 x 2.0	29	749-0439B	Upper Handle
2	714-0104	Cotter Pin .072 x 1.12 Lg.	30	749-0907	Lower Handle
3	720-0241	Knob Ass'y Wingnut 5/16-18	31	631-0071	N Grassbag Cover w/Label
4	726-0240	Strap 4.3 Lg.	32	747-0939	N Pivot Rod
5	736-0451	Wash. Sad. .320 ID x.830 OD	33	726-0106	Cap Nut
6	720-0279	Knob Handle ERS - 1/4-20	34	747-0937	N Frame - Grassbag
9	746-0876	Throttle Lever	35	747-0940	N Rod, Support
10	736-0501	Spring Wash.Curved	36	664-0074	N Grassbag
11	712-0324	Nut 1/4-20 Top locknut Insert	37	710-1250	Cur. Carr. Bolt 5/16-18 x 1" Lg.
12	646-0875	Housing, Throttle	38	712-0267	Hex Nut 5/16-18 Thd.
13	811-00303	Throttle Control - (Includes 9,10,11 & 12)	39	725-1276	Battery Pack - 12 Volt
14	746-0557	Control Cable 47" Lg.	40	731-0891A	Battery Tray
15	746-0841	Cable Throttle 60" Lg.	41	725-0873	Ignition Switch
16	731-0904	Upper Control Housing	42	725-0201	Ignition Key
17	731-0924	6 Speed Shift Lever	43	425-1428	Fuse Holder
				725-0298	Fuse 7-1/2 Amp (Not III.)
18	713-0397	Gear Insert	44	725-1206	Plug
19	710-0841	C Sunk Tap Screw #10 x .75 L	45	725-1442	Wire Harness
20	732-0627	Shift Lever Spring	46	710-0501	Hex Bolt 1/4-20 x 2" Lg.
21	16864	6 Spd. Rack Cable Brkt.	47	736-0270	Bell Wash 1/4" I.D.
22	731-0905	Lower Control Housing	49	782-9012	Lower Battery Tray
23	731-0906	Cable Mounting Cap	50	736-0242	Bell Wash. 5/16" I.D.
24	731-0620	Control Lever	51	710-0969	Truss Mch. Tap Scr. 1" Lg.
25	746-0939	6 Spd. Cable	52	725-1538	Harness Ext.
26	746-0710A	S.P. Cable	53	710-0111	Scr. 1/4-20 x 1.25
27	747-0824	Control Handle	54	712-0287	Hex Nut 1/4-20
28	720-0294	Foam Grip (2 Req'd.)	55	725-0727	Battery Charger

Models 959/979/E979

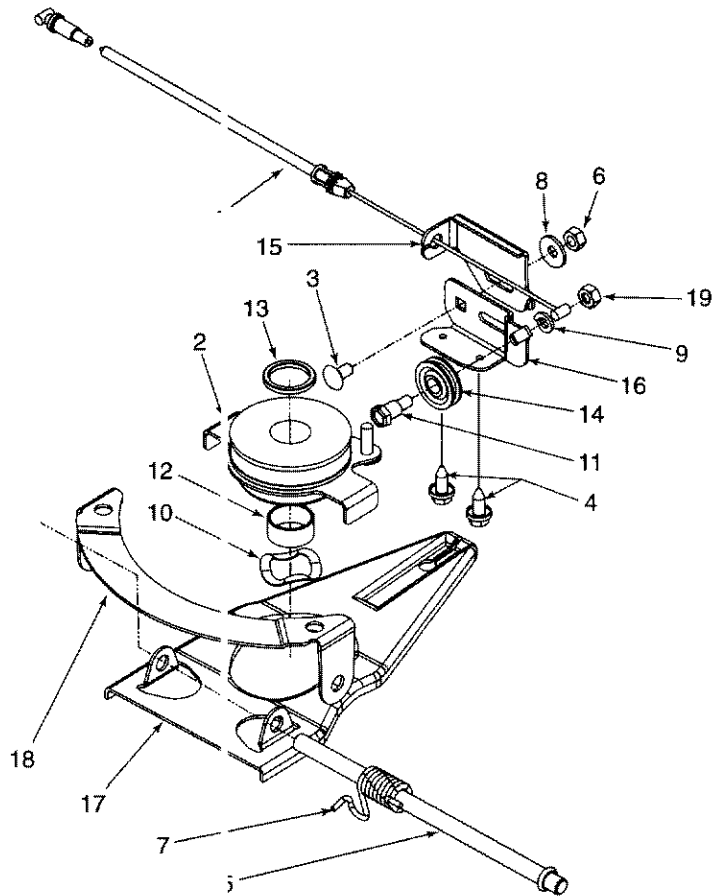

Ref. No.	Par. No.		Description
1	746-093	N	6 Spd. Cable
2	656-061	N	Pulley Ass'y Multi- Spd.
3	710-016		Scr. 1/4-20 x .50 Carr.
4	710-089		Scr. AB 1/4-14 x .625 Hxinwsh
5	711-111	N	Pivot Shaft
6	712-028		Nut 1/4-20
7	732-080		Torsion Spring LH
8	736-027		Bell Wash. .265 X .75 X .062
9	736-032		Lock Wash. 1/4 Reg Duty
10	736-052		Wave Wash. 1.38 x .88 x .029
11	738-092		Shld.Scr. .375 x1/4-14AB
12	750-107		Slev Spcr .88 IDx1.00 OD x.48
13	750-107		Slev Spcr .88ID x1.13ID x .12
14	756-062		Roller Cable
15	782-7574-0665	N	6 Spd. Cable Adj. Bracket
16	782-7575-0665	N	6 Spd. Cable Mt. Bracket
17	782-759	N	6 Sp. Control Arm
18	782-759	N	6 Sp. Pivot Bracket
19	712-013		Hex Nut 1/4-28

Models 959/979/E979

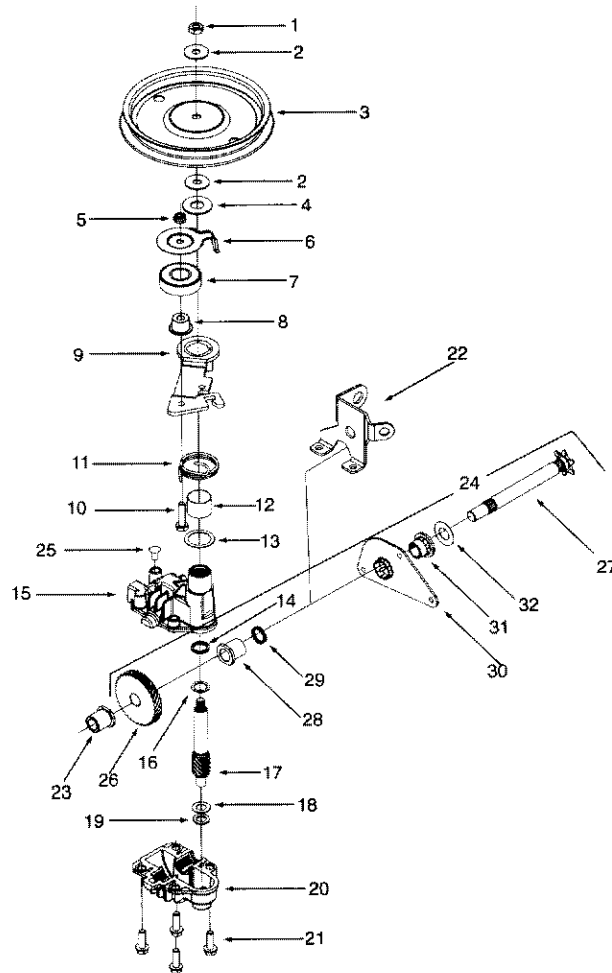

Ref. No.	Part No.	Description	Ref. No.	Part No.	Description
1	712-3025	Hx. Jam Nut 5/16-24	17	717-1468	N Pinion Shaft 10 T.
2	736-0425	Bell Wash. .325 x .930 x .045	18	736-0314	Thr. Wash. 3/8 x .70 x .030
3	756-0656	N Pulley	19	736-0569	N Thr. Wash. .388 x .625 x .062
4	736-3084	Fl. Wash. .510 x 1.120 x .060	20	618-0252	N Lower Housing Ass'y.
5	712-0896	Hx. Jam Nut 1/4-28	21	710-0642	Hx. Scr. 1/2-20 x .75
6	782-7598	N Belt Keeper	22	782-7601	N Cable Bracket
7	741-0600	Bearing	23	741-0674	N Bearing
8	750-1050	N Flange Spacer	24	611-0066	N Shaft Ass'y.
9	682-0027	N Idler Bracket Ass'y.	25	721-0325	Plug
10	710-0299	Hx. Cap Scr. 1/4-28 x 1.00 Gr. 5	26	717-1469	N Gear 34 T.
11	732-0811	N Torsion Spring	27	711-1168	N Output Shaft 6 T.
12	741-0682	N Bearing Sleeve	28	741-0673	N Flange Bearing
13	736-0570	N Fl. Wash. .885 x 1.145 x .030	29	721-0329	Oil Seal
14	721-0329	Oil Seal	30	782-7595	N Pivot Bracket
15	618-0253	N Upper Housing Ass'y.	31	741-0324	Flange Bearing
16	736-0520	N Fl. Wash. .504 x .700 x .030	32	736-0369	Wash. Fl. .508 I.D. x 1.00 O.D. x .020
			-	618-0263	Transmission Comp.

MANUFACTURER'S LIMITED WARRANTY FOR:



For TWO YEARS from the date of retail purchase within the United States of America, its possessions and territories, MTD Products will, at its option, repair or replace, for the original purchaser, free of charge, any part or parts found to be defective in material or workmanship. This warranty covers units which have been operated and maintained in accordance with the owner's instructions furnished with the unit, and which have not been subject to misuse, abuse, commercial use, neglect, accident, improper maintenance or alteration.

Normal wear parts or components thereof are subject to separate terms as noted below in the "No Fault Ninety Day Consumer Warranty" clause.

All normal wear part failures will be covered on this product for a period of 90 days regardless of cause. After 90 days, but within the two year period, normal wear parts failures will be covered ONLY IF caused by defects in material or workmanship of OTHER component parts. Normal wear parts are defined as batteries*, belts, blades, blade adapters, grass bags, rider deck wheels, seats, snow thrower skid shoes, shave plates and tires.

How to obtain service: Warranty service is available, with proof of purchase, through your local authorized service dealer. To locate the dealer in your area, please check the yellow pages or contact the Customer Service Department of MTD Products, P O Box 368022, Cleveland, Ohio 44136-9722.

Phone 1 (800) 800-7310. The return of a complete unit will not be accepted by the factory unless prior written permission has been extended by the Customer Service Department of MTD Products.

Transportation charges: Transportation charges for the movement of any power equipment unit or attachment are the responsibility of the purchaser.

Units exported out of the United States: MTD Products does not extend any warranty for products sold or exported outside of the United States of America, its possessions and territories, except those sold through MTD Products' authorized channels of export distribution.

Other Warranties:

1. The engine or component parts thereof carry separate warranties from their manufacturers. Please refer to the applicable manufacturers warranty on these items.
2. *Batteries are covered by a 90-day replacement warranty.
3. Log splitter pumps, valves and cylinders or component parts thereof are covered by a one year warranty.
4. All other warranties, express or implied, including any implied warranty of merchantability or fitness for a particular purpose, are hereby expressly disclaimed in their entirety.
5. The provisions as set forth in this warranty provide the sole and exclusive remedy of MTD Products' obligations arising from the sales of its products. MTD Products will not be liable for incidental or consequential loss or damage.

How state law relates to this warranty: This limited warranty gives you specific legal rights, and you may also have other rights which vary from state to state. Certain disclaimers are not allowed in some states and therefore they may not apply to you under all circumstances.

Note: This warranty does not cover routine maintenance items such as lubricants, filters, blade sharpening and tune-ups, or adjustments such as brake adjustments, clutch adjustments or deck adjustments. Nor does this warranty cover normal deterioration of the exterior finish due to use or exposure.

For Parts, Accessories or Service Information, Call:

1 (800) 800-7310

Please have your model number ready when you call.

Call Now!

The only way to ensure the performance of your product is to use original equipment parts and accessories. MTD designs and engineers quality parts to exacting specifications. When you substitute, you take a chance on quality, reliability, safety and performance. Use MTD original equipment!

PRODUCT & PURCHASE INFORMATION

Where Purchased:	_____
Address:	_____ _____
Phone Number:	_____
Product Model Number:	_____
Product Serial Number:	_____
Date Purchased:	_____
Product Description:	_____



WARNING: The Engine Exhaust from this product contains chemicals known to the State of California to cause cancer, birth defects or other reproductive harm.