

Operator's Manual

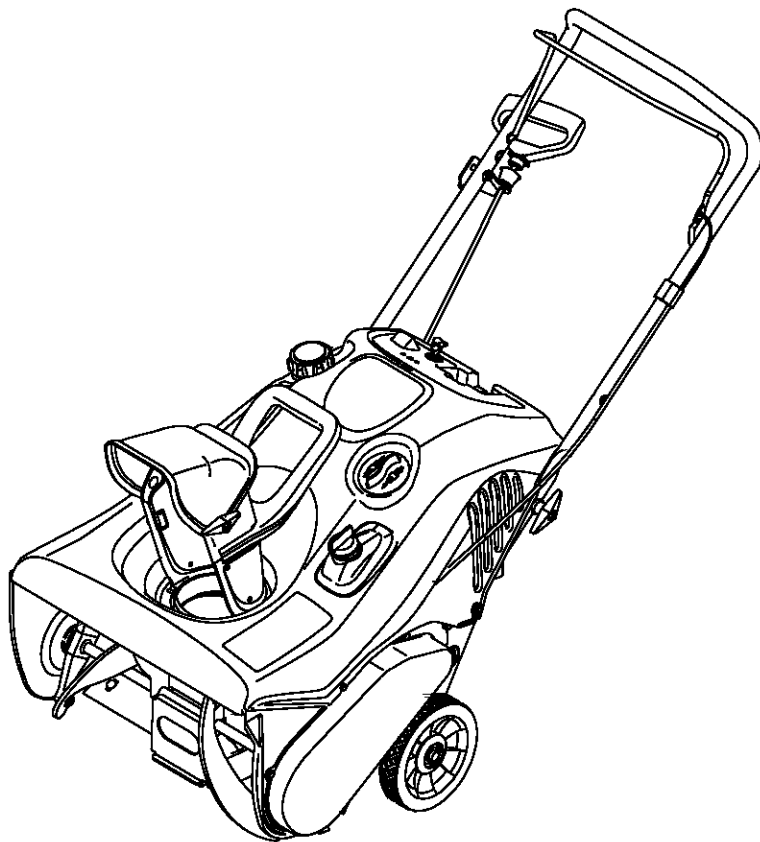

Single Stage Snow Thrower

Models 285 & 295
Models E285 & E295

IMPORTANT: Read safety rules and instructions carefully before operating equipment.

Warning: This unit is equipped with an internal combustion engine and should not be used on or near any unimproved forest-covered, brush-covered or grass-covered land unless the engine's exhaust system is equipped with a spark arrester meeting applicable local or state laws (if any). If a spark arrester is used, it should be maintained in effective working order by the operator. In the State of California the above is required by law (Section 4442 of the California Public Resources Code). Other states may have similar laws. Federal laws apply on federal lands. A spark arrester for the muffler is available through your nearest engine authorized service dealer or contact the service department, P.O. Box 361131 Cleveland, Ohio 44136-0019.

MTD LLC, P.O. BOX 361131 CLEVELAND, OHIO 44136-0019

PRINTED IN U.S.A.

FORM NO. 770-10540C
(7/2003)

TABLE OF CONTENTS

Content	Page
Important Safe Operation Practices	3
Assembling Your Snow Thrower	5
Know Your Snow Thrower.....	6
Operating Your Snow Thrower.....	7
Making Adjustments.....	9
Maintaining Your Snow Thrower	10
Off-Season Storage	10
Troubleshooting	11
Parts List	12

FINDING MODEL NUMBER

This Operator's Manual is an important part of your new snow thrower. It will help you to assemble, prepare and maintain the unit for best performance. Please read and understand what it says.



Before you start assembling your new snow thrower, please locate the model plate on the equipment and copy the information from it in the space provided below. The information on the model plate is very important if you need help from our Customer Support Department or an authorized dealer.

- You can locate the model number by standing behind the unit in the operating position and looking down at the dash panel . A sample model plate is explained below. For future reference, please copy the model number and the serial number of the equipment in the space below.

..... Model Number	
..... Serial Number	
	MTD LLC P. O. BOX 361131 CLEVELAND, OH 44136 330-220-4683 800-800-7310
www.yardman.com	

Copy the model number here: _____

Copy the serial number here: _____

ENGINE INFORMATION

The engine manufacturer is responsible for all engine-related issues with regards to performance, power-rating, specifications, warranty and service. Please refer to the engine manufacturer's Owner's/Operator's Manual packed separately with your unit for more information.

CALLING CUSTOMER SUPPORT

Please do NOT return the unit to the retailer from which it was purchased, without first contacting Customer Support.



If you have difficulty assembling this product or have any questions regarding the controls, operation or maintenance of this unit, please call **1- (330) 220-4MTD (4683)** or **1- (800)-800-7310** to reach a Customer Support representative. Please have your unit's model number and serial number ready when you call. See previous section to locate this information. You will be asked to enter the serial number in order to process your call.

For more details about your unit, visit our website at www.yardman.com

SECTION 1: IMPORTANT SAFE OPERATION PRACTICES



WARNING: This symbol points out important safety instructions which, if not followed, could endanger the personal safety and/or property of yourself and others. Read and follow all instructions in this manual before attempting to operate this machine. Failure to comply with these instructions may result in personal injury. When you see this symbol—**heed its warning.**



WARNING: Engine Exhaust, some of its constituents, and certain vehicle components contain or emit chemicals known to State of California to cause cancer and birth defects or other reproductive harm.

DANGER: This machine was built to be operated according to the rules for safe operation in this manual. As with any type of power equipment, carelessness or error on the part of the operator can result in serious injury. This machine is capable of amputating hands and feet and throwing objects. Failure to observe the following safety instructions could result in serious injury or death.

Training

1. Read, understand, and follow all instructions on the machine and in the manual(s) before attempting to assemble and operate. Keep this manual in a safe place for future and regular reference and for ordering replacement parts.
2. Be familiar with all controls and their proper operation. Know how to stop the machine and disengage them quickly.
3. Never allow children under 14 years old to operate this machine. Children 14 years old and over should read and understand the operation instructions and safety rules in this manual and should be trained and supervised by a parent.
4. Never allow adults to operate this machine without proper instruction.
5. Thrown objects can cause serious personal injury. Plan your snow throwing pattern to avoid discharge of material toward roads, bystanders and the like.
6. Keep bystanders, helpers, pets and children at least 75 feet from the machine while it is in operation. Stop machine if anyone enters the area.
7. Exercise caution to avoid slipping or falling, especially when operating in reverse.
7. Never attempt to make any adjustments while engine is running, except where specifically recommended in the operator's manual.
8. Let engine and machine adjust to outdoor temperature before starting to clear snow.
9. To avoid personal injury or property damage use extreme care in handling gasoline. Gasoline is extremely flammable and the vapors are explosive. Serious personal injury can occur when gasoline is spilled on yourself or your clothes which can ignite. Wash your skin and change clothes immediately.
 - a. Use only an approved gasoline container.
 - b. Extinguish all cigarettes, cigars, pipes and other sources of ignition.
 - c. Never fuel machine indoors.
 - d. Never remove gas cap or add fuel while the engine is hot or running.
 - e. Allow engine to cool at least two minutes before refueling.
 - f. Never over fill fuel tank. Fill tank to no more than ½ inch below bottom of filler neck to provide space for fuel expansion.
 - g. Replace gasoline cap and tighten securely.
 - h. If gasoline is spilled, wipe it off the engine and equipment. Move machine to another area. Wait 5 minutes before starting the engine.
 - i. Never store the machine or fuel container inside where there is an open flame, spark or pilot light (e.g. furnace, water heater, space heater, clothes dryer etc.).
 - j. Allow machine to cool at least 5 minutes before storing.

Preparation

1. Thoroughly inspect the area where the equipment is to be used. Remove all door mats, newspapers, sleds, boards, wires and other objects which could be tripped over or thrown by the auger.
2. Always wear safety glasses or eye shields during operation and while performing an adjustment or repair to protect your eyes. Thrown objects which ricochet can cause serious injury to the eyes.
3. Do not operate without wearing adequate winter outer garments. Do not wear jewelry, long scarves or other loose clothing which could become entangled in moving parts. Wear footwear which will improve footing on slippery surfaces.
4. Use a grounded three wire extension cord and receptacle for all units with electric start engines.
5. Adjust collector housing height to clear gravel or crushed rock surfaces.
6. Disengage the auger control bail before starting the engine.

Operation

1. Do not put hands or feet near rotating parts, in the auger housing or discharge chute. Contact with rotating parts can amputate hands and feet.
2. The auger control bail is a safety device. Never bypass its operation. Doing so, makes the machine unsafe and may cause personal injury.
3. The auger control bail must operate easily in both directions and automatically return to the disengaged position when released.
4. Never operate with a missing or damaged discharge chute. Keep all safety devices in place and working.

5. Never run an engine indoors or in a poorly ventilated area. Engine exhaust contains carbon monoxide, an odorless and deadly gas.
6. Do not operate machine while under the influence of alcohol or drugs.
7. Muffler and engine become hot and can cause a burn. Do not touch.
8. Exercise extreme caution when operating on or crossing gravel surfaces. Stay alert for hidden hazards or traffic.
9. Exercise caution when changing direction and while operating on slopes.
10. Plan your snow throwing pattern to avoid discharge towards windows, walls, cars etc. To avoid property damage or personal injury caused by a ricochet.
11. Never direct discharge at children, bystanders and pets or allow anyone in front of the machine.
12. Do not overload machine capacity by attempting to clear snow at too fast of a rate.
13. Never operate this machine without good visibility or light. Always be sure of your footing and keep a firm hold on the handles. Walk, never run.
14. Disengage power to the auger when transporting or not in use.
15. Never operate machine at high transport speeds on slippery surfaces. Look down and behind and use care when in reverse.
16. If the machine should start to vibrate abnormally, stop the engine, disconnect the spark plug and ground it against the engine. Inspect thoroughly for damage. Repair any damage before starting and operating.
17. Disengage the auger control bail and stop engine before you leave the operating position (behind the handles). Wait until the auger comes to a complete stop before unclogging the discharge chute, making any adjustments, or inspections.
18. Never put your hand in the discharge or collector openings. Always use a clearing tool to unclog the discharge opening.
19. Use only attachments and accessories approved by the manufacturer.
20. If situations occur which are not covered in this manual, use care and good judgment. Contact your dealer or telephone 1-800-800-7310 for assistance and the name of your nearest servicing dealer.

Maintenance & Storage

1. Never tamper with safety devices. Check their proper operation regularly.
2. Disengage the auger control bail and stop engine. Wait until the auger comes to a complete stop. Disconnect the spark plug wire and ground against the engine to prevent unintended starting before cleaning, repairing, or inspecting.
3. Check bolts, and screws for proper tightness at frequent intervals to keep the machine in safe working condition. Also, visually inspect machine for any damage.
4. Do not change the engine governor setting or over-speed the engine. The governor controls the maximum safe operating speed of the engine.
5. Snow thrower shave plates and skid shoes are subject to wear and damage. For your safety protection, frequently check all components and replace with original equipment manufacturer's (O.E.M.) parts only. "Use of parts which do not meet the original equipment specifications may lead to improper performance and compromise safety!"
6. Check the auger control bail periodically to verify they engage and disengage properly and adjust, if necessary. Refer to the adjustment section in this operator's manual for instructions.
7. Maintain or replace safety and instruction labels, as necessary.
8. Observe proper disposal laws and regulations for gas, oil, etc. to protect the environment.
9. Prior to storing, run machine a few minutes to clear snow from machine and prevent freeze up of auger.
10. Never store the machine or fuel container inside where there is an open flame, spark or pilot light such as a water heater, furnace, clothes dryer etc.
11. Always refer to the operator's manual for proper instructions on off-season storage.

Your Responsibility:

- Restrict the use of this power machine to persons who read, understand and follow the warnings and instructions in this manual and on the machine.



SECTION 2: ASSEMBLING YOUR SNOW THROWER

Unpacking From Carton

- Cut along corners of the carton and lay it down flat. Remove packing material.
- Remove any loose parts included with unit (i.e., operator's manual, etc.).
- Roll unit out of carton. Check carton thoroughly for any remaining loose part.

Items Required For Assembly

1. Engine oil
2. Fresh gasoline

NOTE: All references to left or right side of the snow thrower is from the operating position only.

Before Assembly



WARNING: Disconnect the spark plug wire and ground it against the engine to prevent unintended starting. See Figure 1.

Raising Upper Handle

- Loosen the hand knob on each side of the handle. Remove packing material, if any.

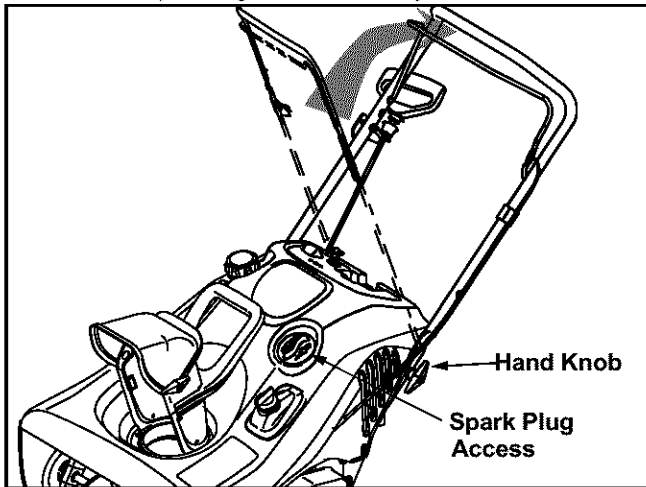

Figure 1

- Raise the upper handle in the direction shown in Figure 1 until it clicks into the operating position. Make sure not to pinch or crimp the cable.
- Tighten the hand knobs.

Assembling the Discharge Chute

For shipping reasons, the snow thrower has been packaged with the upper chute pivoted all the way down. To pivot it upward, proceed as follows:

- Turn the chute until the chute opening is facing straight ahead.
- Remove the wing knob, flat washer and carriage bolt from the lower chute. See Figure 2.
- Pivot the upper chute upward **over the lip on the lower chute** so that there is **NO** gap between the upper chute and the lower chute. See Figure 2.
- Re-secure with the hardware just removed.



CAUTION: Do not use the Chute Handle to lift the machine.

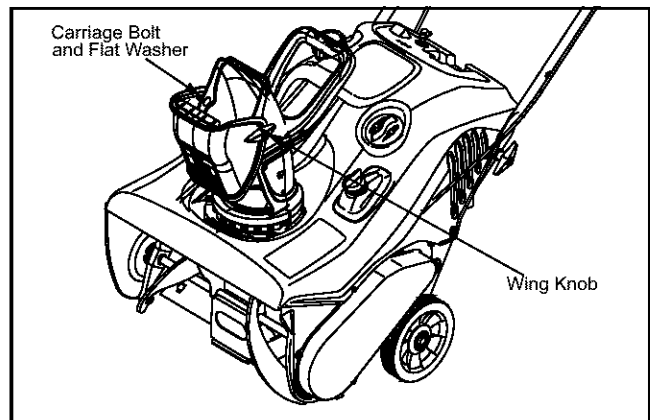

Figure 2

SECTION 3: KNOW YOUR SNOW THROWER



WARNING: Be familiar with all the controls on the snow thrower and their proper operation. Know how to stop the machine and disengage them quickly.

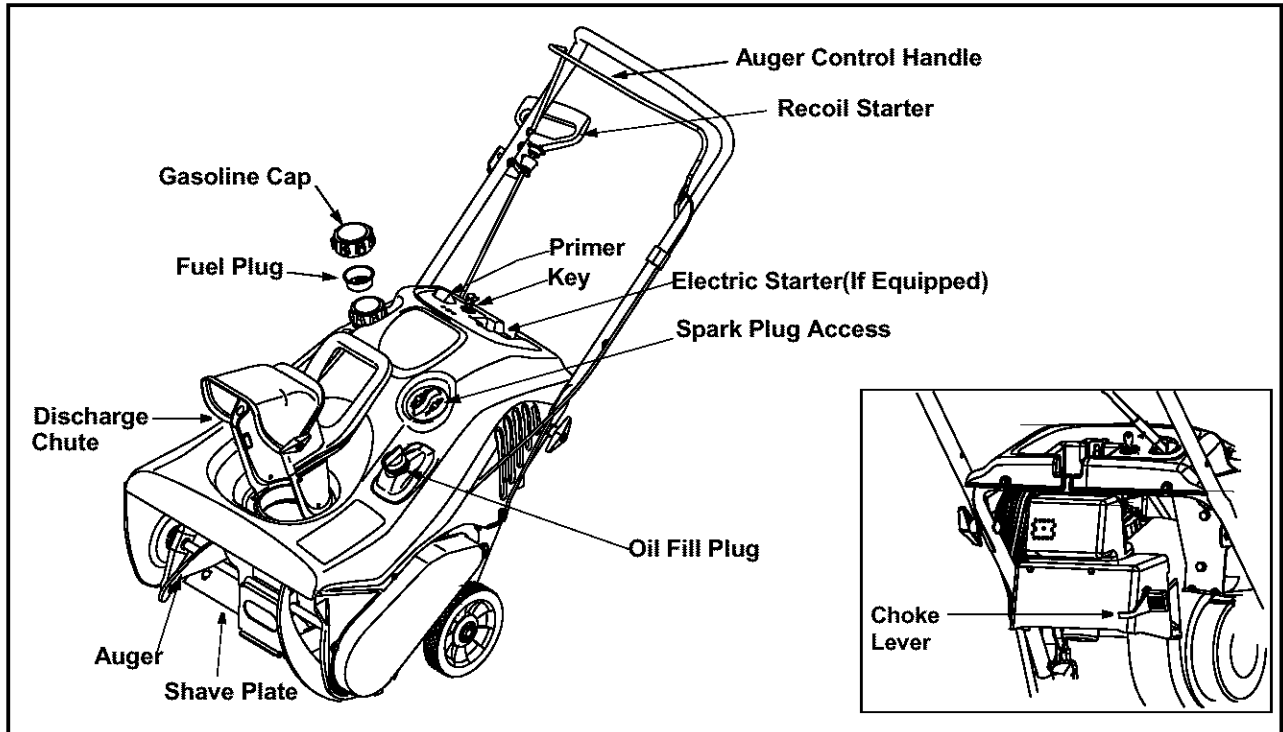

Figure 3

Auger Control Handle

Located on the upper handle, the auger control handle is used to engage and disengage the auger. The snow thrower is designed to propel by the rotation of the auger. Pull the auger control handle back against the upper handle to engage the auger; release to disengage.

Discharge Chute

The angle of the discharge chute controls the distance that the snow is thrown. Tilt the discharge chute up for greater distance; tilt down for less distance. Loosen the hand knob on the side of the discharge chute to adjust. Tilt the chute to the desired position, and tighten the knob.

Choke Lever

The location of the choke lever is indicated in Figure 3 inset. You will have to use this lever to start the engine. Push the lever all the way up to the FULL/ON position, or all the way down to the OFF position as desired.

Fuel Plug

Discard the fuel plug, before filling the fuel tank. It is only used during assembly to keep dirt and debris out of fuel tank.

Primer Button

Used to inject fuel directly into the carburetor to insure fast starts in cold weather. Follow engine manual to prime engine.

Ignition Key

Used to start engine. Put key in "ON" position to start for both electric and recoil start engines. Follow starting instructions given in the next section.

Recoil Starter

Used to manually start the engine.

Electric Starter (If Equipped)

Used to start engine with a 120V power source

Plug for Electric Start

Requires use of a three-prong outdoor extension cord and a 120V power source

Spark Plug Access

Spark plug located under the access cover.

SECTION 4: OPERATING YOUR SNOW THROWER

Before Starting

WARNING: Read, understand, and follow all instructions and warnings on the machine and in this manual before operating.

- The spark plug wire was disconnected for safety. Attach spark plug wire to spark plug before starting.

Gas and Oil Fill-Up

- Check oil and gasoline level and add if necessary. Follow related instructions in the separate engine manual packed with your snow thrower.

WARNING: Use extreme care when handling gasoline. Gasoline is extremely flammable and the vapors are explosive. Never fuel the machine indoors or while the engine is hot or running. Extinguish cigarettes, cigars, pipes and other sources of ignition.

To Start Engine

- Insert ignition key into slot. Turn key to ON position.
- Now follow the instructions below as it pertains to your unit. See Figure 4 for location of controls.

Electric Starter(If Equipped)

WARNING: The electric starter must be used with a properly grounded three-prong receptacle at all times to avoid the possibility of electric shock. Follow all instructions carefully prior to operating the electric starter.

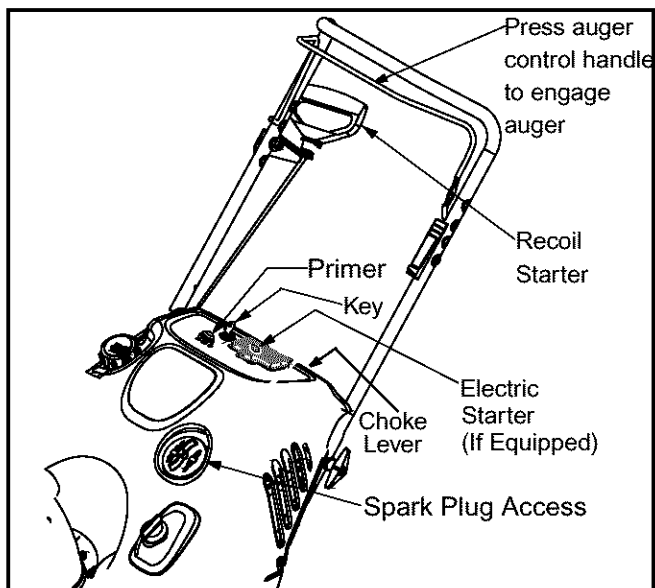

Figure 4

- The electric starter is equipped with a grounded three-wire power cord and plug, and is designed to operate on 120 volt AC household current.
- Determine that your house wiring is a three-wire grounded system. Ask a licensed electrician if you are not certain.
- **If your home wiring system is not a three-wire grounded system**, do not use this electric starter under any conditions.
- **If your home electrical system is grounded**, but a three-hole receptacle is not available, one should be installed by a licensed electrician before using the electric starter.
- **If you have a grounded three-prong receptacle**, proceed as follows.
- Move Choke Control to "Full" position.
- Push Primer three (3) times, making sure to cover vent hole when pushing. Connect power cord to switch box on dash panel. Plug the other end of power cord into a three-prong 120-volt, grounded, AC receptacle.
- Push starter button to crank engine. As you crank the engine, move choke lever to FULL choke position.
- When engine starts, release starter button, and move choke gradually to OFF. If engine falters, move choke immediately to FULL and then gradually to OFF.
- When disconnecting the power cord, always unplug from the three-prong receptacle first, and then from the snow thrower.

Recoil Starter

- Move choke lever to FULL choke position (cold engine start).
- If engine is warm, place choke in OFF position instead of FULL.
- Push primer button two or three times for cold engine start.
- If engine is warm, push primer button only once.

NOTE: Always cover vent hole in primer button when pushing. Additional priming may be necessary for first start if temperature is below 15 degrees Fahrenheit.

- Grasp starter handle and pull rope out slowly, until it pulls slightly harder. Let rope rewind slowly.
- Pull starter handle rapidly. Do not allow handle to snap back. Allow it to rewind slowly while keeping a firm hold on the starter handle.
- As engine warms up and begins to operate evenly, rotate choke lever slowly to OFF position. If engine falters, return to FULL choke, then slowly move to OFF position.

To Stop Engine

- To stop engine, turn ignition key counter-clockwise. Disconnect the spark plug wire from the spark plug to prevent accidental starting while equipment is unattended.

To help prevent possible freeze-up of starter, proceed as follows:

- Run engine for a few minutes before stopping to help dry off any moisture on the engine.
- **Electric Starter (If Equipped):** Connect power cord to switch box on engine, then to 120 volt AC receptacle. With the engine running, push starter button and spin the starter for several seconds. The unusual sound made by spinning the starter will not harm engine or starter. Disconnect the power cord from receptacle first, and then from switch box.
- **Recoil Starter:** With engine running, pull starter rope with a rapid, continuous full arm stroke three or four times. Pulling the starter rope will produce a loud clattering sound, which is not harmful to the engine or starter.
- Wipe all snow and moisture from the carburetor cover in the area of the control levers. Also, move control levers back and forth several times. Leave throttle control lever in the STOP or OFF position. Leave choke control in the FULL choke position.
- Remove ignition key and disconnect spark plug wire to prevent accidental starting.

Operating the Snow Thrower

The pitch of the discharge chute controls the angle at which the snow is thrown.

- Loosen the wing knob found on the left side of the discharge chute and pivot the upper chute upward or downward to the desired pitch. Retighten the wing knob before operating the snow thrower.

- Position the discharge chute opening by using the Chute Handle to throw the snow in the desired direction. See Figure 5.

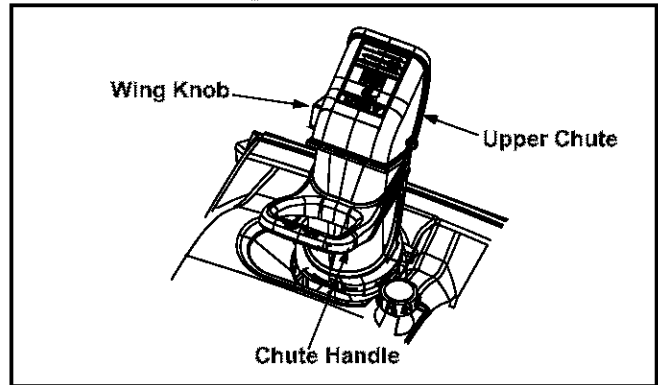

Figure 5

Operating Tips

- Discharge snow downwind whenever possible. Slightly overlap each previously cleared path.
- Lifting up on the handle will allow the rubber on the augers to propel the snow thrower forward. Pushing downward on the handle will raise the augers off the ground and stop forward motion.

NOTE: Excessive upward pressure on the handle will result in premature wear on the rubber auger blades which would not be covered by warranty.

- Run the engine for a few minutes before stopping to help dry any moisture on the engine.
- Clean the snow thrower thoroughly after each use.



WARNING: Muffler, engine and surrounding areas become hot and can cause a burn. Do not touch.

SECTION 5: MAKING ADJUSTMENTS



WARNING: NEVER attempt to make any adjustments while the engine is running, except where specified in the operator's manual.

Shave Plate

- To check the adjustment of the shave plate, place the unit on a level surface. See Figure 6. The wheels, shave plate and augers should all contact level surface. Note that if the shave plate is adjusted too high, snow may blow under the housing. If the shave plate wears out excessively, or the unit does not self-propel, the shave plate may be too low and needs to be adjusted.

NOTE: On new units or units with a new shave plate installed, the augers may be slightly off the ground.

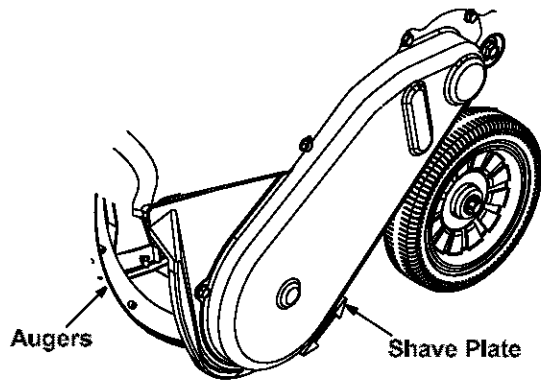
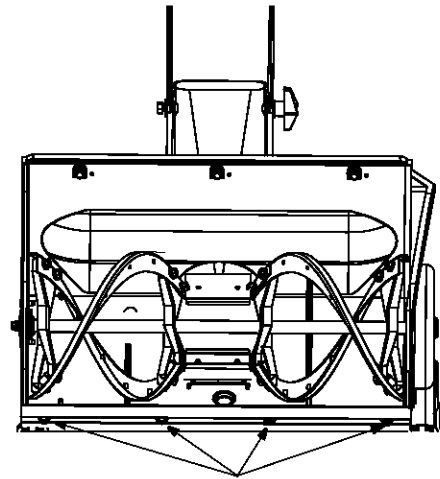

Figure 6

- To adjust, tip the snow thrower back so that it rests on the handle. Loosen the four lock nuts and bolts which secure the shave plate to the housing. See Figure 7. Move the shave plate to desired position and retighten the nuts and bolts securely.



Lock Nut & Carriage Bolt

Figure 7

Control Cable

As a result of both the control cable and the drive belt stretching due to wear, periodic adjustments may be necessary.

If the auger seems to hesitate when rotating while the engine maintains a constant speed, an adjustment is necessary. Proceed as follows:

The upper hole in the control handle provides an adjustment in cable tension. To adjust, disconnect the end of control cable from the bottom hole in the control handle and reinsert it in the upper hole. Test the snow thrower to see if there is a noticeable difference.

Carburetor



WARNING: If any adjustments need to be made to the engine while the engine is running (e.g. carburetor), keep clear of all moving parts. Be careful of muffler, engine and other surrounding heated surfaces.

- Refer to the separate engine manual, packed with your unit, for carburetor adjustment information.

SECTION 6: MAINTAINING YOUR SNOW THROWER



WARNING: Before servicing, repairing, or inspecting, disengage the auger control bail and stop engine. Wait until all moving parts have come to a complete stop. Disconnect spark plug wire and ground it against the engine to prevent unintended starting.

Replacing Belt

- Remove the belt cover by removing five hex screws. See Figure 8.

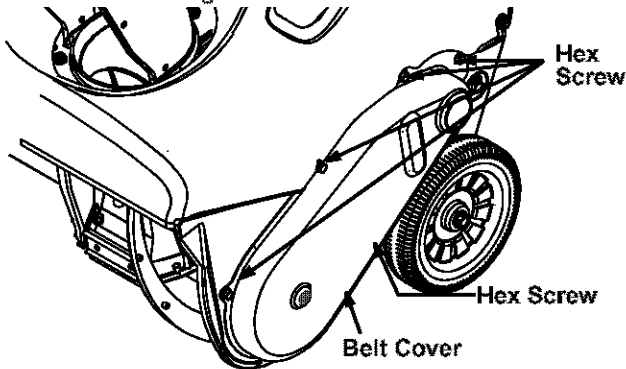

Figure 8

- Pull up on the idler pulley and slip the belt off the engine and auger pulley. See Figure 9.

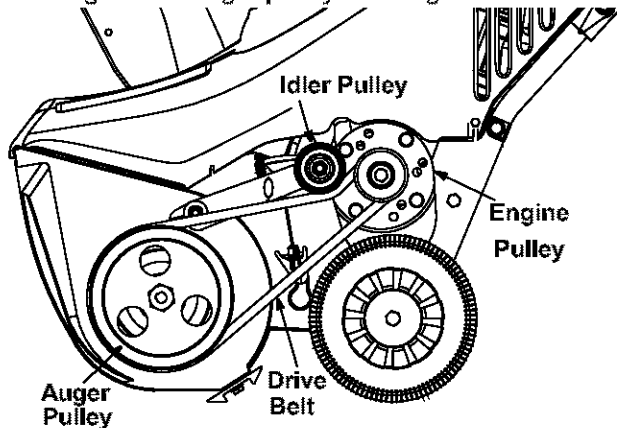

Figure 9

- Reassemble new belt. Reinstall the belt cover.

Replacing Shave Plate

The shave plate is attached to the bottom of the auger housing and is subject to wear. It should be checked periodically. There are two wearing edges and the shave plate can be reversed. Refer to Figure 6.

- Remove the four carriage bolts and hex lock nuts which attach it to the snow thrower housing.
- Install new shave plate, making sure the heads of the carriage bolts are on the inside of the housing.
- Adjust the shave plate according to instructions on page 9. Tighten securely.

Engine

- Refer to the separate engine manual for all engine maintenance procedures.
- Check engine and snow thrower frequently for loose hardware, and tighten as needed.

Lubrication

Lubricate pivot points on the auger control handle and the extension spring at the end of the control cable with a light oil once every season and before storage of the snow thrower at the end of the season.

Replacing the Auger's Rubber Paddles

The snow thrower auger's rubber paddles are subject to wear and should be replaced if any signs of excessive wear is present.

NOTE: Call 1-800-800-7310 for information regarding the price and availability of Auger Kit 753-04472 or contact an authorized MTD Service Dealer in your area).

To change the rubber paddles, proceed as follows:

- Remove the existing rubber paddles by unthreading the self-tapping screws which secure them to the auger.
- Secure the replacement rubber paddles to the auger using the hardware removed earlier.

SECTION 7: OFF-SEASON STORAGE



WARNING: Never store engine with fuel in tank indoors or in enclosed, poorly ventilated areas where fuel fumes may reach an open flame, spark or pilot light as on a furnace, water heater, clothes dryer, or other gas appliance.

- Clean snow thrower thoroughly.
- Lubricate as instructed above with a light oil.
- Follow "Storage" instructions in the Engine Manual.

- Store in a clean, dry area. Block the snow thrower up so it is not resting on the rubber auger blades.

NOTE: When storing in a metal storage shed, rustproof the equipment, especially springs, cables and all moving parts. When storing any type of power equipment in a poorly ventilated or metal storage shed, care should be taken to rustproof the equipment, especially springs, cables and all moving parts.

SECTION 8: TROUBLESHOOTING GUIDE

Problem	Cause	Remedy
Engine fails to start	<ol style="list-style-type: none"> 1. Fuel tank empty, or stale fuel 2. Blocked fuel line 3. Key not in ON position 4. Spark plug wire disconnected 5. Faulty spark plug 6. Engine not primed 7. Engine flooded with excessive priming 	<ol style="list-style-type: none"> 1. Fill tank with clean fresh gasoline. 2. Clean fuel line 3. Insert key and turn to ON position 4. Connect wire to spark plug. 5. Clean spark plug, readjust gap, or replace. 6. Prime engine four times. 7. Wait at least ten minutes before starting.
Engine runs erratic	<ol style="list-style-type: none"> 1. Unit running on choke 2. Fuel line blocked, or stale fuel 3. Water or dirt in fuel system 4. Carburetor out of adjustment 	<ol style="list-style-type: none"> 1. Move choke lever to OFF position. 2. Clean fuel line and fill tank with fresh, clean gasoline. 3. Refer to engine manual for remedy. 4. Refer to engine manual for remedy.
Engine overheats	<ol style="list-style-type: none"> 1. Carburetor out of adjustment 	<ol style="list-style-type: none"> 1. Refer to engine manual for instruction.
Loss of power	<ol style="list-style-type: none"> 1. Spark plug wire loose 2. Vent in gas cap plugged 	<ol style="list-style-type: none"> 1. Connect and tighten spark plug wire. 2. Clear vent.
Excessive vibration	<ol style="list-style-type: none"> 1. Loose parts or damaged auger 	<ol style="list-style-type: none"> 1. Stop engine immediately and disconnect spark plug wire. Check for possible damage. Tighten all bolts and nuts. Repair as needed. If the problem persists, take unit to an authorized service dealer.
Unit fails to self-propel	<ol style="list-style-type: none"> 1. Control cable out of adjustment 2. Drive belt loose or damaged 	<ol style="list-style-type: none"> 1. Adjust control cable following instructions on page 9 of this manual. 2. Replace drive belt
Unit fails to discharge snow	<ol style="list-style-type: none"> 1. Discharge chute clogged 2. Foreign object lodged in auger 3. Control cable not adjusted properly 4. Drive belt loose or damaged 	<ol style="list-style-type: none"> 1. Stop engine immediately and disconnect spark plug wire. Clean discharge chute and the auger housing. 2. Stop engine immediately and disconnect spark plug wire. Remove object. 3. Adjust control cable following instructions on page 9 of this manual. 4. Replace drive belt.

NOTE: For repairs beyond the minor adjustments listed above, contact your nearest authorized service representative or call 1-800-800-7310 for the Customer Support Center. Refer to the engine manual for more engine related information.

SECTION 9: PARTS LIST FOR MODELS 285, E285, 295 & E295

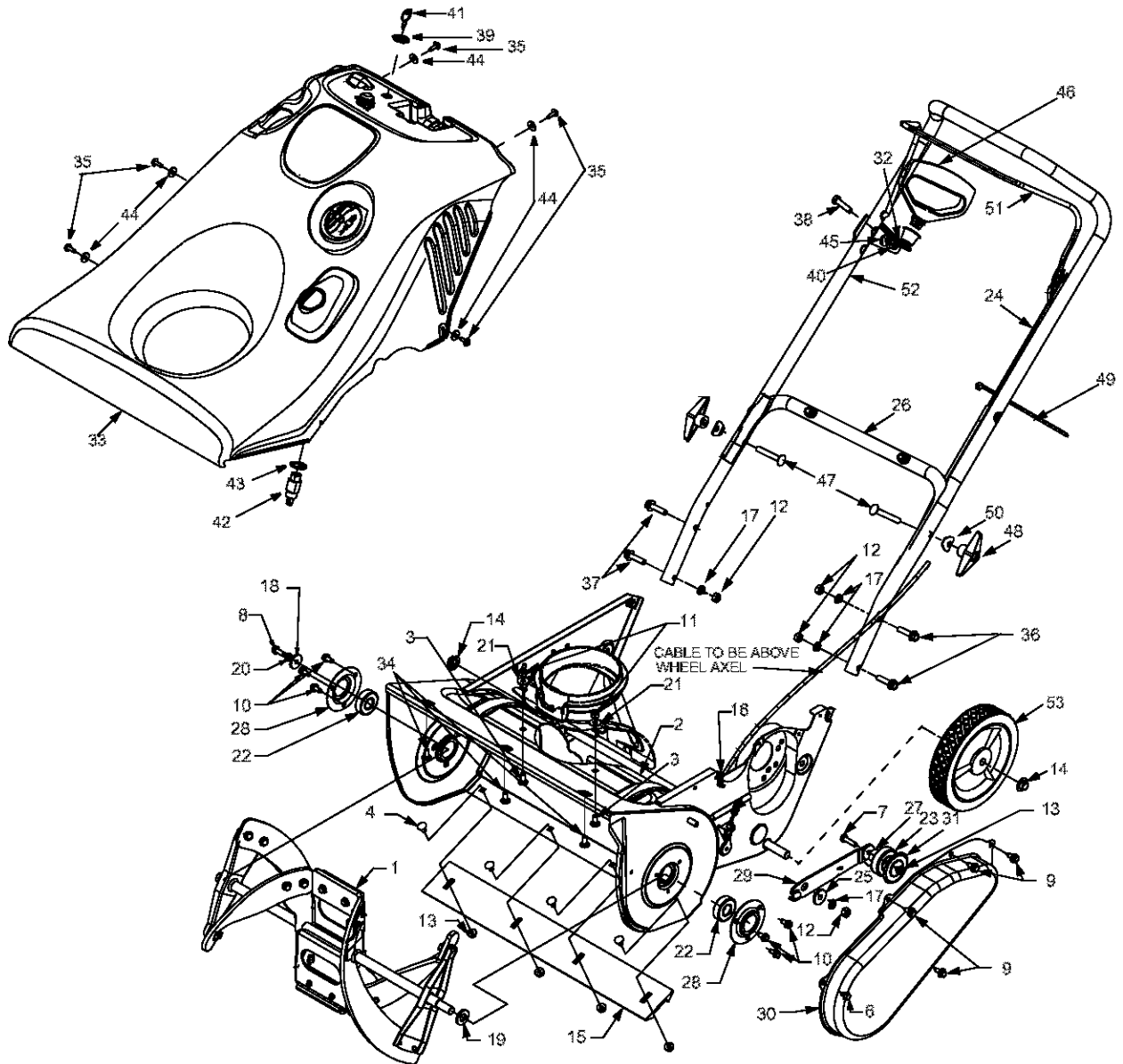

Models 285, E285, 295 & E295

REF. NO.	PART NO.	DESCRIPTION	REF. NO.	PART NO.	DESCRIPTION
1	684-04027	Auger Ass'y 21" complete w/Solid Shaft	28	784-5174	Bearing Cup
2	684-04028	Auger Housing Ass'y 21"	29	790-00039	Idler Bracket w/Brake
3	710-0134	Screw, 1/4-20 x .62	30	790-00045	Belt Cover
4	710-0167	Carriage Bolt 1/2-20 x .50 LG	31	790-00062	Belt Keeper
5	710-0323	Truss Mach Scr 5/16-18 x .75	32	684-0178	Mitten Grip Bracket
6	710-0352	Hex "B" Tap Scr. 1/4-14 x .375" LG	33	684-04031	Shroud Ass'y, 7HP Yellow
7	710-0597	Hex Screw 1/4-20 x 1.00 Gr. 5	33	684-04032	Shroud Ass'y, 5HP Yellow
8	710-0642	Hex Tap Scr. 1/4-20 x .75"	34	710-0895	Screw, 1/4-15 x .75
9	710-0896	Hex Screw AB:1/4-14 x 0.625"	35	710-1003	Hex Wash B-Tapp Scr #10-16 x .625" Lg.
10	710-1005	Hex Tap Scr. 1/4-14 x .50" LG.	36	710-1090	Hex Flange Screw, 5/16-18x 1.25
11	712-0324	Hex Nut, 1/4-20 Nylon	37	710-1882	Hex Flange Screw 5/16-18 x 1.50 Gr. 5
12	712-3010	Hex Nut 5/16-18 hd. Gr. 5	38	710-3083	Hex Screw, 5/16-18 x 1.375
13	712-3027	Hex Flange Nut, 1/4-20	39	712-0252	Hex Nut 5/8-32 x .12 Special
14	726-0299	Push Cap x 1/2" Rod	40	712-0429	Hex Nut, 5/16-18 Gr 5 Nylon
15	731-1033	Shave Plate 2.66 x 19.88 Double	41	725-0201	Ignition Key
16	732-0357A	Extension Spring .33 OD x 1.12 Lg.	42	725-2018	Key Switch-Electric Start
17	736-0119	L-Wash 5/16 ID	43	736-0225	L-Washer Internal .625 ID x 1.058 OD
18	736-0176	Flat Washer .265 ID x .938 OD x .120	44	736-0400	Flat Washer .194" ID x .62" OD x .063
19	736-0326	Flat Washer .510 ID x 1.00 OD x .125	45	736-0451	Saddle Washer .320 ID x .93 OD
20	736-0329	Lock Washer, 1/4	46	7519636	Recoil Handle, Mitten
21	736-3090	Flat Washer .260 x .720 x .060	47	710-0487	Carriage Bolt 5/16-18 x 2.0 Gr. 1
22	741-0600	Ball Bearing 17 x 40 x 12	48	720-0284	Handle Knob Assembly 5/16-18
23	741-0919	Ball Bearing	49	710-0157	Hex Screw 5/16-24 x .75 Gr. 5
24	746-04091	Control Cable	50	710-0451	Carriage Bolt, 5/16-18 x.075 GR 1
25	748-0234	Shoulder Spacer .25 THK	51	747-04159	Gull Wing Bail
26	749-04114	Lower Handle	52	749-04106	Upper Handle, Gull Wing
27	750-04230	Flange Spacer	53	734-04062	Wheel, 7 x 1.5 Star Yellow

NOTE: For painted parts, please refer to the list of color codes below. Please add the applicable color code, wherever needed, to the part number to order a replacement part. For instance, if a part numbered 700-xxxx is painted powder black, the part number to order would be 700-xxxx-0637.

Yardman Green- 0665

Models 285, E285, 295 & E295

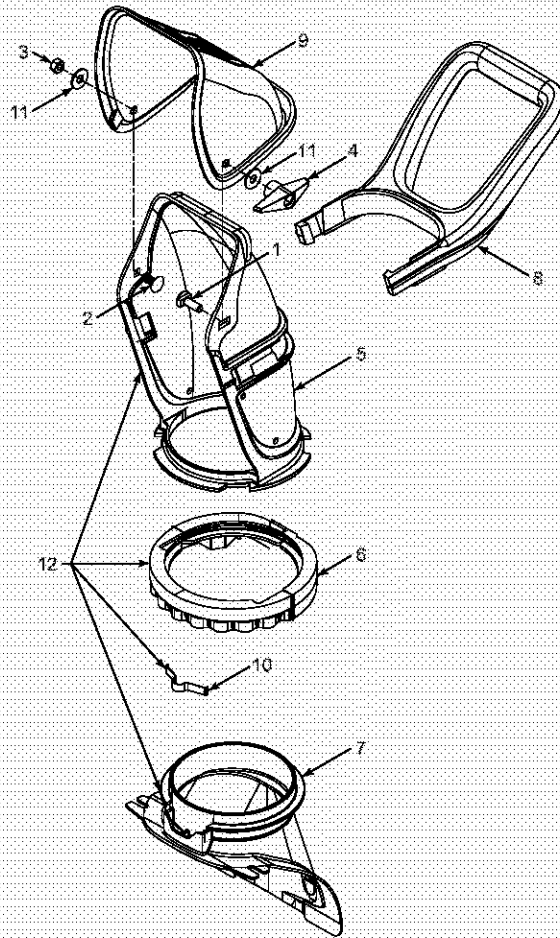

REF. NO.	PART NO.	DESCRIPTION
1	710-04071	Carriage Screw, 5/16-18 x 1.0
2	710-0451	Carriage Bolt, 5/16-18 x.075 GR 1
3	712-3068	Hex Patch I-Nut 5/16-18'
4	720-0284	Handle Knob Assembly 5/16-18
5	731-04127	Lower Chute 5" Dia
6	731-04353	Ring-Lower Chute
7	731-04373	Chute, Adapter 5" Dia
8	731-04388	Handle-Chute 5" Dia
9	731-04429	Upper Chute w/Export Label
10	732-04111	Chute Adjustment Spring
11	736-0159	Flat Washer, .349 ID x .879 OD x .063
12	684-04049	Lower Chute Ass'y (Incl. #5-7 and 10)

Models 285, E285, 295 & E295

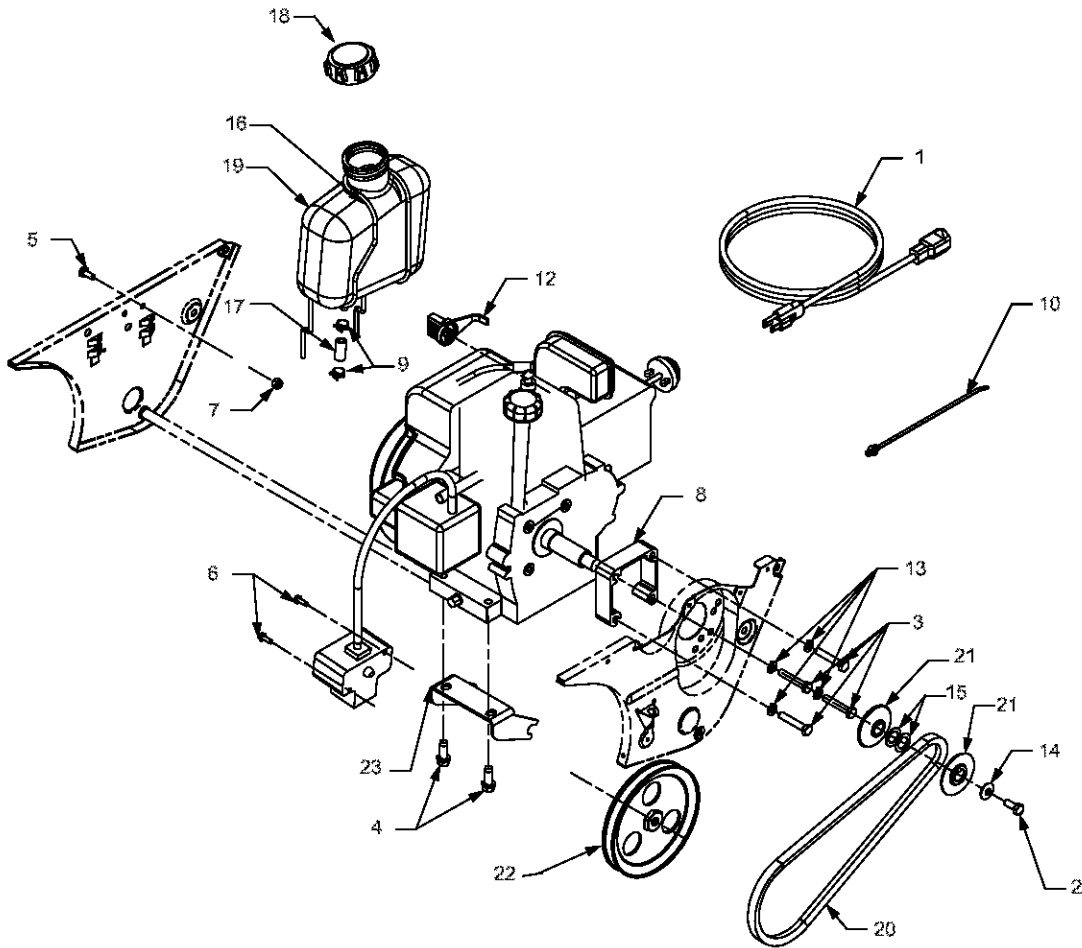

REF. NO.	PART NO.	DESCRIPTION
1	629-0071	Extension Cord
2	710-0157	Hex Screw, 5/16-24 x .75
3	710-0409	Hex Screw, 5/16-24 x 1.75
4	710-0654A	Self Tapping Screw, 3/8-16 x 1.00
5	710-0751	Hex Screw, 1/4-20 x .62
6	710-1003	Screw, #10-16 x .625
7	712-0324	Hex Nut, 1/4-20 Nylon
8	719-0581	Spacer, Engine 4 Cycle
9	726-0205	Clamp, Hose
10	726-0470	Cable Tie
12	731-2825	Knob, Choke
13	736-0119	Washer, Lock 5/16
14	736-0242	Bell Washer, .340 x .872 x .060
15	736-0337	Flat Washer, 5/8 ID x 1.0 OD
16	747-04169	Support, Wire Gas Tank
17	751-0535	Hose, Fuel Line
18	751-0603	Cap, Fuel
19	751-10023	Tank, Fuel
20	751-0101A	V-Belt 1/2 x 35.0 LG
21	756-04060	Pulley Half, .625 ID x 2.25 OD
22	756-0475	Pulley, 1/2 V 1/2-20 LH x 6.0
23	790-00047	Bracket, Engine 4 Cycle

MANUFACTURER'S LIMITED WARRANTY FOR:



The limited warranty set forth below is given by MTD LLC with respect to new merchandise purchased and used in the United States, its possessions and territories.

"MTD" warrants this product against defects in material and workmanship for a period of two (2) years commencing on the date of original purchase and will, at its option, repair or replace, free of charge, any part found to be defective in materials or workmanship. This limited warranty shall only apply if this product has been operated and maintained in accordance with the Operator's Manual furnished with the product, and has not been subject to misuse, abuse, commercial use, neglect, accident, improper maintenance, alteration, vandalism, theft, fire, water, or damage because of other peril or natural disaster. Damage resulting from the installation or use of any part, accessory or attachment not approved by MTD for use with the product(s) covered by this manual will void your warranty as to any resulting damage.

Normal wear parts or components thereof are subject to separate terms as follows: All normal wear parts or component failures will be covered on the product for a period of 90 days regardless of cause. After 90 days, but within the two year period, normal wear part failures will be covered ONLY IF caused by defects in materials or workmanship of OTHER component parts. Normal wear parts and components include, but are not limited to: batteries, belts, blades, blade adapters, grass bags, rider deck wheels, seats, snow thrower skid shoes, shave plates, auger spiral rubber, and tires.

HOW TO OBTAIN SERVICE: Warranty service is available, WITH PROOF OF PURCHASE, through your local authorized service dealer. To locate the dealer in your area, check your Yellow Pages, or contact MTD LLC at P.O. Box 361131, Cleveland, Ohio 44136-0019, or call 1-800-800-7310 or log on to our Web site at www.mtdproducts.com.

This limited warranty does not provide coverage in the following cases:

- a. The engine or component parts thereof. These items may carry a separate manufacturer's warranty. Refer to applicable manufacturer's warranty for terms and conditions.
- b. Log splitter pumps, valves, and cylinders have a separate one year warranty.
- c. Routine maintenance items such as lubricants, filters, blade sharpening, tune-ups, brake adjustments, clutch adjustments, deck adjustments, and normal deterioration of the exterior finish due to use or exposure.
- d. MTD does not extend any warranty for products sold or exported outside of the United States, its possessions and territories, except those sold through MTD's authorized channels of export distribution.
- e. Replacement parts that are not genuine MTD parts.
- f. Service completed by someone other than an authorized service dealer.
- g. Transportation charges and service calls.

No implied warranty, including any implied warranty of merchantability of fitness for a particular purpose, applies after the applicable period of express written warranty above as to the parts as identified. No other express warranty, whether written or oral, except as mentioned above, given by any person or entity, including a dealer or retailer, with respect to any product, shall bind MTD. During the period of the warranty, the exclusive remedy is repair or replacement of the product as set forth above.

The provisions as set forth in this warranty provide the sole and exclusive remedy arising from the sale. MTD shall not be liable for incidental or consequential loss or damage including, without limitation, expenses incurred for substitute or replacement lawn care services or for rental expenses to temporarily replace a warranted product.

Some states do not allow the exclusion or limitation of incidental or consequential damages, or limitations on how long an implied warranty lasts, so the above exclusions or limitations may not apply to you.

In no event shall recovery of any kind be greater than the amount of the purchase price of the product sold. **Alteration of safety features of the product shall void this warranty.** You assume the risk and liability for loss, damage, or injury to you and your property and/or to others and their property arising out of the misuse or inability to use the product.

This limited warranty shall not extend to anyone other than the original purchaser or to the person for whom it was purchased as a gift.

HOW STATE LAW RELATES TO THIS WARRANTY: This limited warranty gives you specific legal rights, and you may also have other rights which vary from state to state.

IMPORTANT: Owner must present Original Proof of Purchase to obtain warranty coverage.

MTD LLC, P.O. BOX 361131 CLEVELAND, OHIO 44136-0019; Phone: 1-800-800-7310