

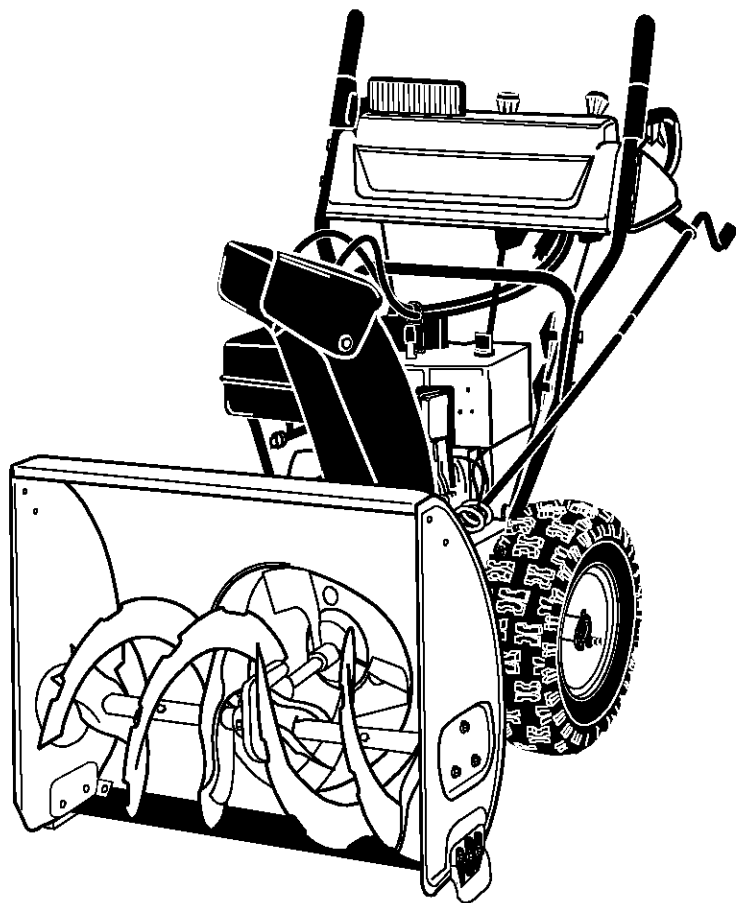

OPERATOR'S MANUAL



Model Series
993
Snow Thrower



IMPORTANT: READ SAFETY RULES AND INSTRUCTIONS CAREFULLY

Warning: This unit is equipped with an internal combustion engine and should not be used on or near any unimproved forest-covered, brush-covered or grass-covered land unless the engine's exhaust system is equipped with a spark arrester meeting applicable local or state laws (if any). If a spark arrester is used, it should be maintained in effective working order by the operator. In the State of California the above is required by law (Section 4442 of the California Public Resources Code). Other states may have similar laws. Federal laws apply on federal lands. A spark arrester for the muffler is available through your nearest engine authorized service dealer or contact the service department, P.O. Box 368022 Cleveland, Ohio 44136-9722.

MTD PRODUCTS INC P.O. BOX 368022 CLEVELAND, OHIO 44136-9722

SECTION 1: FINDING YOUR MODEL NUMBER

This Operator's Manual is an important part of your new snow thrower. It will help you assemble, prepare and maintain your snow thrower. Please read and understand what it says.

Before you start to prepare your snow thrower for its first use, please locate the model plate and copy the information from it in this Operator's Manual. The information on the model plate is very important if you need help from your dealer.

- Every snow thrower has a model plate. You can locate it by standing behind the unit in the operating position and looking down at the frame cover.
- The model plate will look like Figure 1.

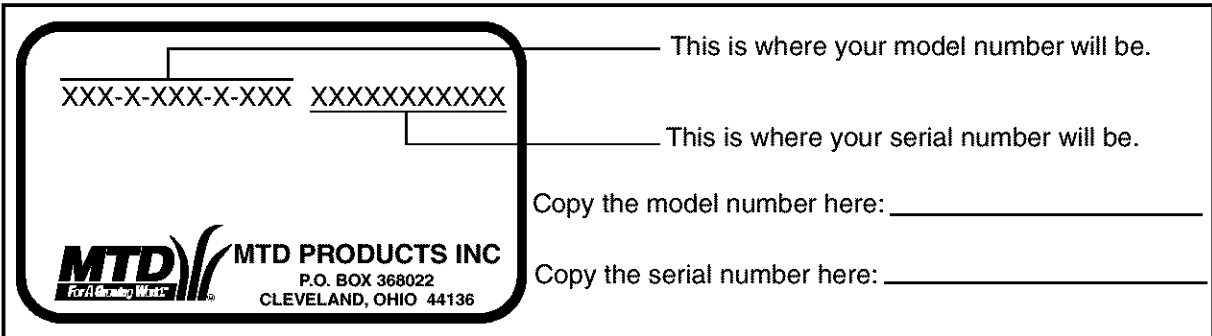

Figure 1

SECTION 2: CALLING CUSTOMER SUPPORT

- **LOCATE YOUR MODEL NUMBER AND SERIAL NUMBER** — Record this information in the space provided. To find your unit's specific model number and serial number, see SECTION 1: FINDING YOUR MODEL NUMBER.
- If you are having difficulty assembling this product or if you have any questions regarding the controls, operation or maintenance of this unit, please call the Customer Support Department.
- Customer Support can be reached by dialing: **1- (330) 220-4MTD (4683)**
or
1- (800)-800-7310
- Please have your model number and serial number ready when you call.
- Although both numbers are important, you will be asked to enter only your *serial* number before your call can be processed.

SECTION 3: IMPORTANT SAFE OPERATION PRACTICES



WARNING: THIS SYMBOL POINTS OUT IMPORTANT SAFETY INSTRUCTIONS WHICH, IF NOT FOLLOWED, COULD ENDANGER THE PERSONAL SAFETY AND/OR PROPERTY OF YOURSELF AND OTHERS. READ AND FOLLOW ALL INSTRUCTIONS IN THIS MANUAL BEFORE ATTEMPTING TO OPERATE YOUR SNOW THROWER. FAILURE TO COMPLY WITH THESE INSTRUCTIONS MAY RESULT IN PERSONAL INJURY. WHEN YOU SEE THIS SYMBOL- HEED ITS WARNING.



WARNING: The Engine Exhaust from this product contains chemicals known to the State of California to cause cancer, birth defects or other reproductive harm.



DANGER: Your snow thrower was built to be operated according to the rules for safe operation in this manual. As with any type of power equipment, carelessness or error on the part of the operator can result in serious injury. If you violate any of these rules, you may cause serious injury to yourself or others.

1. TRAINING

- Read this operator's manual carefully in its entirety before attempting to assemble or operate this machine. Be completely familiar with the controls and the proper use of this machine before operating it. Keep this manual in a safe place for future and regular reference and for ordering replacement parts.
- Never allow children under 14 years old to operate a snow thrower. Children 14 years old and over should only operate snow thrower under close parental supervision. Only persons well acquainted with these rules of safe operation should be allowed to use your snow thrower.
- No one should operate this unit while intoxicated or while taking medication that impairs the senses or reactions.
- Keep the area of operation clear of all persons, especially small children and pets.
- Exercise caution to avoid slipping or falling, especially when operating in reverse.
- Before working with gasoline, extinguish all cigarettes and other sources of ignition. Check the fuel before starting the engine. Gasoline is an extremely flammable fuel. Do not fill the gasoline tank indoors, while the engine is running, or until engine has been allowed to cool at least two minutes. Replace gasoline cap securely and wipe off any spilled gasoline before starting the engine as it may cause a fire or explosion.
- Use a grounded three wire plug-in for all units with electric drive motors or electric starting motors.
- Adjust collector housing height to clear gravel or crushed rock surface.
- Never attempt to make any adjustments while engine is running (except where specifically recommended by manufacturer).
- Let engine and machine adjust to outdoor temperature before starting to clear snow.
- Always wear safety glasses or eye shields during operation or while performing an adjustment or repair, to protect eyes from foreign objects that may be thrown from the machine in any direction.

2. PREPARATION

- Thoroughly inspect the area where the equipment is to be used and remove all door mats, sleds, boards, wires and other foreign objects.
- Disengage all clutches before starting engine.
- Do not operate equipment without wearing adequate winter outer garments. Do not wear jewelry, long scarfs or other loose clothing which could become entangled in moving parts. Wear footwear which will improve footing on slippery surfaces.

3. OPERATION

- Do not put hands or feet near or under rotating parts. Keep clear of discharge opening and auger at all times.
- Exercise extreme caution when operating on or crossing gravel drives, walks, or roads. Stay alert for hidden hazards or traffic. Do not carry passengers.
- After striking a foreign object, stop the engine, remove wire from spark plug, and thoroughly inspect the snow thrower for any damage. Repair the damage before restarting and operating the snow thrower.

- If the snow thrower should start to vibrate abnormally, stop the engine and check immediately for the cause. Vibration is generally a warning of trouble.
- Stop engine whenever you leave the operating position, before unclogging the collector/impeller housing or discharge guide, and making any repairs, adjustments, or inspections. Never place your hand in the discharge or collector openings. Use a stick or wooden broom handle to unclog the discharge opening.
- Take all possible precautions when leaving the unit unattended. Disengage the collector/impeller, stop the engine, and remove the key.
- When cleaning, repairing, or inspecting, make certain collector/impeller and all moving parts have stopped. Disconnect spark plug wire and keep away from plug to prevent accidental starting.
- Do not run engine indoors, except when starting engine and transporting snow thrower in or out of building. Open doors. Exhaust fumes are dangerous.
- Do not clear snow across the face of slopes. Exercise extreme caution when changing direction on slopes. Do not attempt to clear steep slopes.
- Never operate snow thrower without guards, plates, or other safety protection devices in place.
- Never operate snow thrower near glass enclosure, automobiles, window wells, drop off, etc., without proper adjustments of snow thrower discharge angle. Keep children and pets away.
- Do not overload machine capacity by attempting to clear snow at too fast a rate.

- Never operate the machine at high transport speeds on slippery surfaces. Look behind and use care when backing.
- Never direct discharge at bystanders or allow anyone in front of unit.
- Disengage power to collector/impeller when transporting or not in use.
- Use only attachments and accessories approved by the manufacturer of snow thrower (such as wheel weights, counter weights, cabs, etc.).
- Never operate the snow thrower without good visibility or light. Always be sure of your footing and keep a firm hold on the handles. Walk, never run.
- Muffler and engine become hot and can cause a burn. Do not touch.

4. MAINTENANCE AND STORAGE

- Check shear bolts, engine mounting bolts, etc., at frequent intervals for proper tightness to be sure equipment is in safe working condition.
- Never store the machine with fuel in the fuel tank inside a building where ignition sources are present, such as hot water and space heaters, clothes dryers, and the like. Allow engine to cool before storing in any enclosure.
- Always refer to operator's manual instructions for important details if snow thrower is to be stored for an extended period.
- Run machine a few minutes after throwing snow to prevent freeze up of collector/impeller.
- Check clutch controls periodically to verify they engage and disengage properly and readjust if necessary. Refer to operator's manual for adjustment instructions.



WARNING - YOUR RESPONSIBILITY: Restrict the use of this power machine to persons who read, understand and follow the warnings and instructions in this manual and on the machine.



Figure 2 Safety Labels Found on Snow Thrower

SECTION 4: SET-UP INSTRUCTIONS

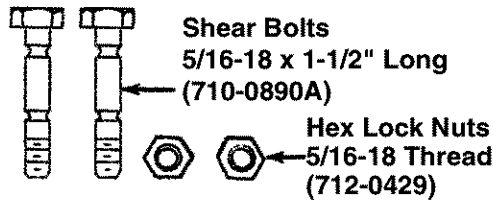

AUGER SHEAR BOLTS

The augers are secured to the auger shaft with two shear bolts and hex lock nuts. If you hit a foreign object or ice jam, the snow thrower is designed so that the bolts will shear. Two replacement shear bolts and nuts are provided for your convenience. Store in a safe place until needed

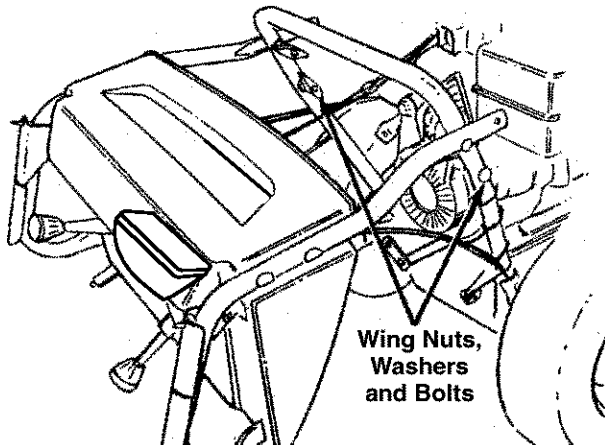

Figure 3

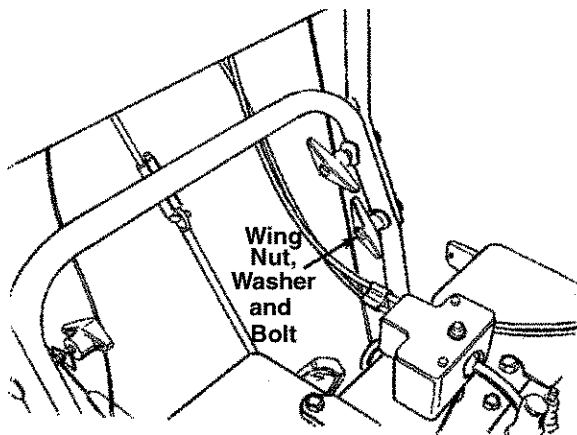

Figure 4

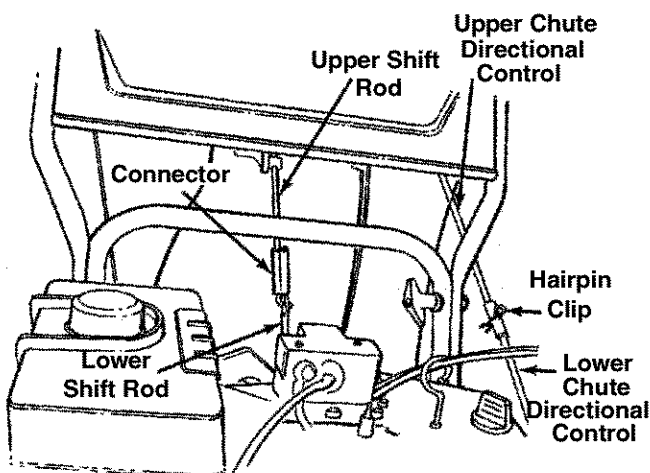

Figure 5

NOTE: Reference to right or left side of the snow thrower is from behind the unit in the operating position.

IMPORTANT: Check the adjustments as instructed on page 6, and make any final adjustments necessary before operating your snow thrower. Failure to follow the instructions may cause damage to the snow thrower.

1. Remove screws from the top sides and ends of the shipping crate.
2. Set top, side, and end panels aside to avoid tire punctures or personal injury.
3. Remove and discard plastic bag that covers unit.
4. Roll unit out of crate.
5. Remove the **lower** two plastic wing nuts, cupped washers and carriage bolts from each side of the upper handle. See Figure 3.
6. The chute directional control may be attached to the lower handle with cable ties for shipping purposes, if so, cut the cable ties and remove the chute directional control at this time.
7. Raise the upper handle assembly until it locks over the lower handle. See Figure 3 and Figure 4.
8. Secure the upper handle and lower handle with the two plastic wing nuts, cupped washers and carriage bolts previously removed. See Figure 4.
9. Slide the shift rod connector down over the end of the lower shift rod. See Figure 5. Tap the connector until it **locks** on the lower shift rod.

NOTE: If the connector is not properly assembled, the shift rod will pivot and you will not be able to shift gears or change directions.

10. Remove the hairpin clip from the end of the upper chute directional control. Slide the upper chute directional control into the lower chute directional control. Align the holes, and secure with hairpin clip. See Figure 5.

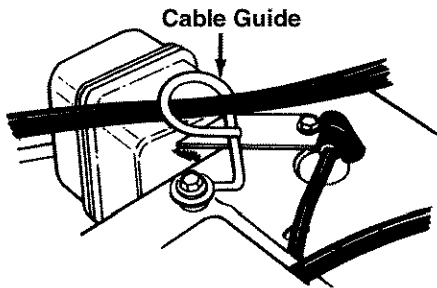

Figure 6

11. If not already attached, slip the cables that run from the handle panel to the chute into the cable guide located on top of the engine. See Figure 6.
12. Unwrap the headlight wire which is attached to the headlight, beneath the handle panel. Wind the headlight wire around the right handle until excess slack is removed.
13. Plug the wire from the headlight into the wire lead coming from the right side of the engine, underneath the fuel tank.

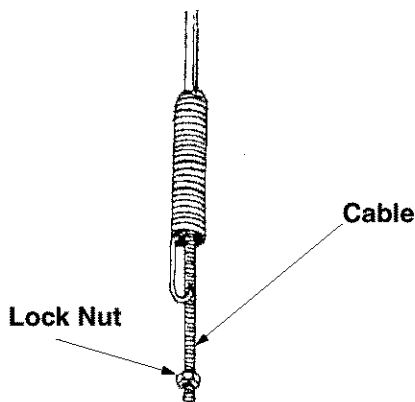

Figure 7

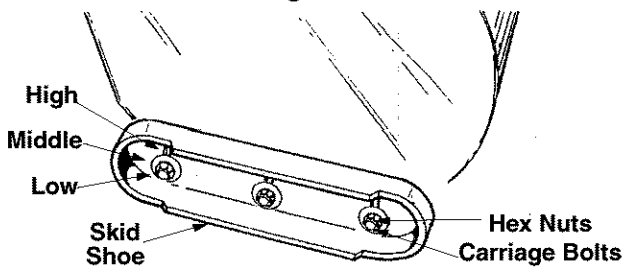

Figure 8

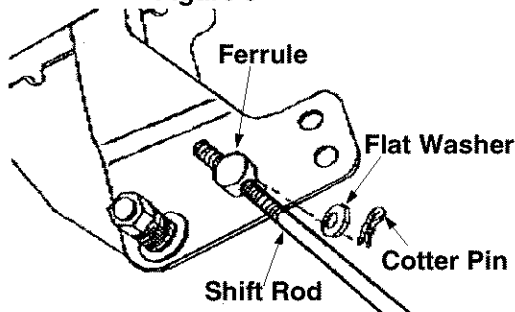

Figure 9

FINAL ADJUSTMENTS

Auger and Traction Control Clutch Adjustment

To check the adjustment of either drive clutch, push forward on the clutch grip (depress the rubber bumper). There should be slack in the cable. Release the clutch grip. The cable should be straight, but not tight. Make certain you can depress the clutch grip against the handle completely.

If necessary, thread lock-nut up to increase tension or down to decrease tension. See Figure 7.

Skid Shoe Adjustment (See Figure 8)

The space between the shave plate and the ground can be adjusted. For close snow removal, place skid shoes in the low position. Use middle or high position when area to be cleared is uneven. See Figure 8.

Adjust skid shoes by loosening the six hex nuts and carriage bolts and moving skid shoes to desired position. Make certain the entire bottom surface of skid shoe is against the ground to avoid uneven wear on the skid shoes. Tighten nuts and bolts securely. The skid shoes may be reversed for even wear.

Shift Lever Adjustment (See Figure 9)

If unit does not engage properly into first gear, it may be necessary to remove the cotter pin and washer from the shift rod and thread the ferrule one counterclockwise turn.

TIRE PRESSURE (Pneumatic Tires)

The tires are over-inflated for shipping purposes. Check tire pressure and reduce to 15 to 20 psi. (Check sidewall of tire for manufacturer's recommendation)

NOTE: If the tire pressure is not equal in both tires, the unit may pull to one side or the other.

SECTION 5: CONTROLS

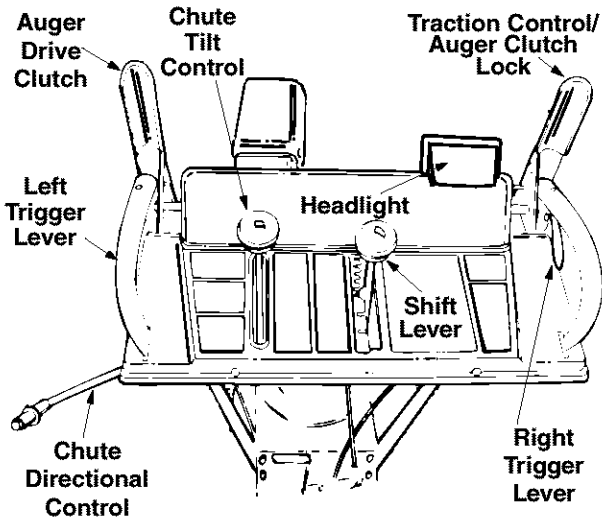

Figure 10

SHIFT LEVER

(See Figures 10 and 11)

The shift lever is located in the center of the handle panel. The shift lever may be moved into one of eight positions. Run engine with throttle in the fast position. Use the shift lever to determine ground speed.

Forward—one of six speeds. Position number one (1) is the slowest. Position number six (6) is the fastest.

Reverse—two reverse (R) speeds. “R” closest to the operator (all the way back) is the faster of the two.



Figure 11

AUGER CONTROL (See Figure 10)

The auger control clutch is located on the left handle. Squeeze the clutch grip to engage the augers. Release to stop the snow throwing action. (Traction control clutch must also be released.)

TRACTION CONTROL/AUGER CLUTCH LOCK

(See Figure 10)

The traction control clutch is located on the right handle. Squeeze the traction control clutch to engage the wheel drive. Release to stop.

This same lever also locks the auger clutch so you can turn the chute directional control without interrupting the snow throwing process. If the auger control clutch is engaged with the traction control clutch engaged, the operator can release the auger control clutch (on the left handle) and the augers will remain engaged. Release the traction control clutch to stop both the augers and wheel drive (auger control clutch must also be released).

TRIGGER LEVERS (See Figure 10)

The trigger levers are located on the underside of the handles and are used to help you steer your snow thrower. To turn right, squeeze the right trigger lever and guide the snow thrower to the right. To turn left, squeeze the left trigger lever and guide the snow thrower to the left. These controls should be used while operating your snow thrower in open areas until you become familiar with their operation. Lift both triggers for easy transport when the engine is not running.

CHUTE DIRECTIONAL CONTROL

(See Figure 10)

The chute directional control is located on left hand side of the snow thrower.

To change the direction in which snow is thrown, turn chute directional control as follows:

1. Crank clockwise to discharge to the left.
2. Crank counterclockwise to discharge to the right.

CHUTE TILT CONTROL (See Figure 10)

The distance snow is thrown can be adjusted by adjusting the angle of the chute assembly. Move the chute tilt control forward to decrease the distance, toward the rear to increase.

HEADLIGHT (See Figure 10)

The headlight is on whenever the engine is running.

THROTTLE CONTROL (See Figure 12)

The throttle control is located on the engine. It regulates the speed of the engine.

SAFETY IGNITION SWITCH (See Figure 12)

The ignition key must be inserted in the switch before the unit will start. Remove the ignition key when snow thrower is not in use.

FUEL SHUT-OFF VALVE

The fuel shut-off valve, located under fuel tank, controls fuel flow from tank.

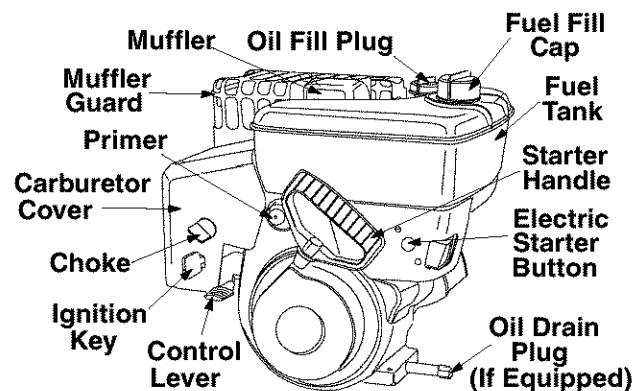
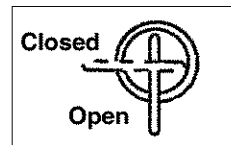

Figure 12

SECTION 6: OPERATION

NOTE: This unit has been shipped with oil in the engine. Check oil before starting engine.

GAS AND OIL FILL-UP

Check oil level and add oil if necessary. Service the engine with gasoline as instructed in the separate engine manual packed with your snow thrower. Read instructions carefully.



WARNING: Never fill fuel tank indoors, with the engine running or while engine is hot. Do not smoke when filling fuel tank.

TO START ENGINE

IMPORTANT: If unit shows any sign of motion (drive or augers) with the clutch grips disengaged, shut off engine immediately. Readjust as instructed in the FINAL ADJUSTMENTS on page 6.

Electric Starter



WARNING: The electric starter is equipped with a three-wire power cord and plug, and is designed to operate on 120 volt AC household current. It must be properly grounded at all times to avoid the possibility of electric shock which may be injurious to the operator. Follow all instructions carefully. Determine that your house wiring is a three wire grounded system. Ask a licensed electrician if you are not certain. If your house wiring system is not a three-wire grounded system, do not use this electric starter under any conditions. If your system is grounded and a three hole receptacle is not available at the point your starter will normally be used, one should be installed by a licensed electrician.

When connecting the power cord, always connect cord to starter on engine first, then plug the other end into a three-hole grounded receptacle.

When disconnecting the power cord, always unplug the end from the three-hole grounded receptacle first.

1. Attach spark plug wire to spark plug. Make certain the metal loop on the end of the spark plug wire (inside the boot) is fastened securely over the metal tip on the spark plug. See Figure 13.
2. Make certain the auger and traction control clutch levers are in the disengaged (released) position.
3. Move throttle control up to FAST position. Insert ignition key into slot. Refer to Figure 12. Be certain it snaps into place. Do not turn key.
4. Rotate choke knob to OFF position.

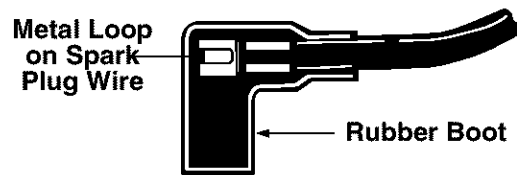

Figure 13

ENGINE WILL NOT START UNLESS IGNITION KEY IS INSERTED INTO IGNITION SLOT IN CARBURETOR COVER. DO NOT TURN IGNITION KEY.

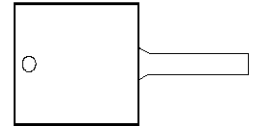

Figure 14

5. Connect power cord to switch box on engine. Plug the other end of power cord into a three-hole, grounded 120 volt AC receptacle.
6. Push starter button to crank engine. Refer to Figure 12. As you crank the engine, move choke knob to FULL choke position.
7. When engine starts, release starter button, and move choke gradually to OFF. If engine falters, move choke immediately to FULL and then gradually to OFF.

Recoil Starter

1. From the starting instructions for an Electric starter, follow step 1 through step 3.
2. Rotate choke knob to FULL choke position (cold engine start).
If engine is warm, place choke in OFF position instead of FULL.
3. Push primer button two or three times. Refer to Figure 12.
If engine is warm, push primer button once only.

NOTE: Always cover vent hole in primer button when pushing. Additional priming may be necessary for first start if temperature is below 15°F.

4. Grasp starter handle (refer to Figure 12) and pull rope out slowly, until it pulls slightly harder. Let rope rewind slowly.
5. Pull starter handle rapidly. Do not allow handle to snap back. Allow it to rewind slowly while keeping a firm hold on the starter handle.
6. Repeat step 4 and step 5 until engine starts.
7. As engine warms up and begins to operate evenly, rotate choke knob slowly to OFF position. If engine falters, return to FULL choke, then slowly move to OFF position.

TO STOP ENGINE

1. Run engine for a few minutes before stopping to help dry off any moisture on the engine.
2. To help prevent possible freeze-up of starter, proceed as follows:
Optional Electric Starter Connect power cord to switch box on engine, then to 120 volt AC receptacle. With the engine running, push starter button and spin the starter for several seconds. The unusual sound made by spinning the starter will not harm engine or starter. Disconnect the power cord from receptacle first, and then from switch box.
Recoil Starter With engine running, pull starter rope with a rapid, continuous full arm stroke three or four times. Pulling the starter rope will produce a loud clattering sound, which is not harmful to the engine or starter.
3. To stop engine, remove the ignition key. Do not turn key. Disconnect the spark plug wire from the spark plug to prevent accidental starting while equipment is unattended.

NOTE: Do not lose ignition key. Keep it in a safe place. Engine will not start without the ignition key.

4. Wipe all snow and moisture from the carburetor cover in the area of the control levers. Also, move control levers back and forth several times.

TO ENGAGE DRIVE

1. With the engine running near top speed, move shift lever into one of the six FORWARD positions or two REVERSE positions. Select a speed appropriate for the snow conditions that exist. Use the slower speeds until you are familiar with the operation of the snow thrower.
2. Squeeze the left hand auger clutch grip and engage it.
3. While the left hand auger clutch grip is engaged, engage the right hand traction control clutch grip.
4. Release the left hand auger clutch grip only. The interlock mechanism should keep the left hand clutch engaged until the right hand clutch is released.

NOTE: NEVER move shift lever without first releasing the traction control clutch.

TIRE PRESSURE

Pneumatic tires only Tires are over-inflated for shipping purposes. Correct tire pressure is 10-15 psi. (Check sidewall of tire for manufacturer's recommendation.)

TIRE CHAINS

Tire chains should be used whenever extra traction is needed.

OPERATING TIPS

NOTE: Allow the engine to warm up for a few minutes as the engine will not develop full power until it reaches operating temperature.



WARNING: Temperature of muffler and surrounding areas may exceed 150° F. Avoid these areas.

1. For most efficient snow removal, remove snow immediately after it falls.
2. Discharge snow downwind whenever possible. The distance snow is thrown can be adjusted by adjusting the angle of the chute assembly. The sharper the angle, the shorter the distance snow is thrown. Slightly overlap each previous swath.
3. Set the skid shoes 1/4" below the shave plate for normal usage. The skid shoes may be adjusted upward for hard-packed snow. Adjust downward when using on gravel or crushed rock.
4. Be certain to follow the precautions listed under previous section, "To Stop Engine" to prevent possible freeze up.
5. Clean the snow thrower thoroughly after each use.

SECTION 7: ADJUSTMENTS



WARNING: NEVER attempt to clean chute or make any adjustments while engine is running.

REMOTE CHUTE ASSEMBLY ADJUSTMENT

The remote chute control cables have been pre-adjusted at the factory. Move the remote chute lever on the control panel back and forward to adjust angle of the chute assembly.

CHECK ADJUSTMENT OF CLUTCH CABLES

Proper adjustment is achieved by sliding the spring up the cable and threading the nut in or out. Correct adjustment on cables is minimal slack but not tight.

AUGER BELT TENSION ADJUSTMENT

Periodic adjustment of the belt tension may be required due to normal stretch and wear on the belt. Increase belt tension if the augers hesitate while the augers are engaged or decrease tension if the augers continue to turn when the augers are disengaged. Refer to Proper Adjustment on page 12.

SHIFT ROD ADJUSTMENT

To adjust the shift rod, remove the cotter pin which secures the shift rod to the shift lever. For proper adjustment, refer to FINAL ADJUSTMENTS on page 6.

SKID SHOE ADJUSTMENT

The space between the shave plate and the ground can be adjusted. Refer to Skid Shoe Adjustment (See Figure 8) on page 6.

CARBURETOR ADJUSTMENT



WARNING: If any adjustments are made to the engine while the engine is running (e.g. carburetor), keep clear of all moving parts. Be careful of heated surfaces and mufflers.

Minor carburetor adjustment may be required to compensate for differences in fuel, temperature, altitude and load.

Refer to the separate engine manual packed with your unit for carburetor adjustment information.

NOTE: Failure to comply with suggested maintenance and lubrication specifications on pages 10 and 11 will void warranty.

SECTION 8: LUBRICATION

WHEELS

Oil or spray lubricant into bearings at wheels at least once a season. Remove wheels, clean and coat axles with a multi-purpose automotive grease. See Figure 15.

CHAINS AND SHIFTING MECHANISM

Remove lower cover. Oil all chains, sprockets, bearings, the hexagonal shaft, round shaft, and shifting mechanism at least once a season. Use engine oil or a spray lubricant. Avoid getting oil on rubber friction wheel and aluminum drive plate.

CHUTE DIRECTIONAL CONTROL WORM

The worm gear on the chute directional crank should be greased with multi-purpose automotive grease.

IMPELLER PULLEY

The impeller pulley should be lubricated once a season. Refer to exploded view of parts, found in the back of the book, for correct location.

AUGER SHAFT

Remove auger bolts on auger shaft, see Figure 16. Oil or spray lubricant inside shaft.

ENGINE

Refer to engine manual for engine lubrication instructions.

HEX SHAFT

Lubricate the hex shaft with a good all-weather multi-purpose light grease at least once a season or after every 25 hours of operation (available from an authorized service dealer or an automotive store.) See Figure 15.

If for any reason your transmission was disassembled and the auger cable disconnected, make sure when reassembling to pass the cable above the hex shaft before reconnecting to the auger actuator bracket.



WARNING: When following instructions in separate engine manual for draining oil, be sure to protect frame to avoid oil dripping onto transmission parts.

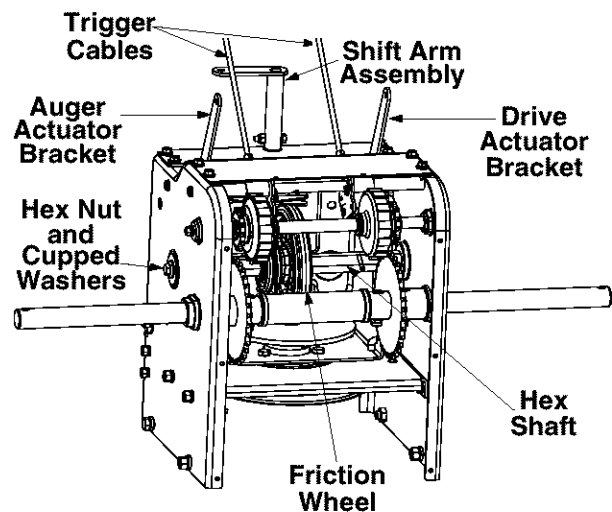

Figure 15 Viewed from the underside of snow thrower

SECTION 9: MAINTENANCE



WARNING: Disconnect the spark plug wire and ground against the engine before performing any repairs or maintenance.

AUGERS

The augers are secured to the spiral shaft with two shear bolts and hex lock nuts. See Figure 16. If you hit a foreign object or ice jam, the snow thrower is designed so that the shear bolts will shear.

If the augers will not turn, check to see if the hex bolts have sheared. Two replacement shear bolts and hex lock nuts have been provided with the snow thrower. When replacing bolts, spray an oil lubricant into shaft before inserting new bolts.

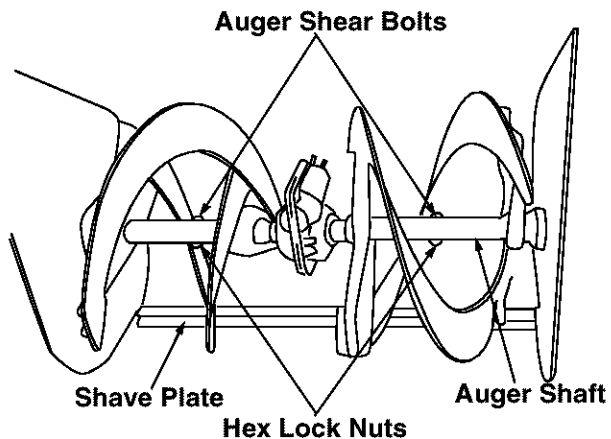

Figure 16

SHAVE PLATE AND SKID SHOES

The shave plate and skid shoes on the bottom of the snow thrower are subject to wear. They should be checked periodically and replaced when necessary.

NOTE: All models are equipped with reversible skid shoes.

To remove skid shoes, remove the carriage bolts, Belleville washers and hex nuts which attach them to the snow thrower. Reassemble new skid shoes with the carriage bolts, Belleville washers (cupped side goes against skid shoes) and hex nuts.

To remove shave plate, remove the carriage bolts, Belleville washers and hex nuts which attach it to the snow thrower housing. Reassemble new shave plate, making sure heads of the carriage bolts are to the inside of the housing. Tighten securely.

BELT REMOVAL AND REPLACEMENT



WARNING: Remove the spark plug wire from the spark plug and ground. Drain gasoline from the fuel tank, or place a piece of plastic film underneath the gas cap to prevent gasoline from leaking.

Auger Belt

To remove and replace either the auger belt or the drive belt, proceed with the following instructions:

1. Disconnect chute directional control assembly at the discharge chute by removing the cotter pin and flat washer.
2. Remove the plastic belt cover on the front of the engine by removing three self-tapping screws and flat washers. See Figure 17.

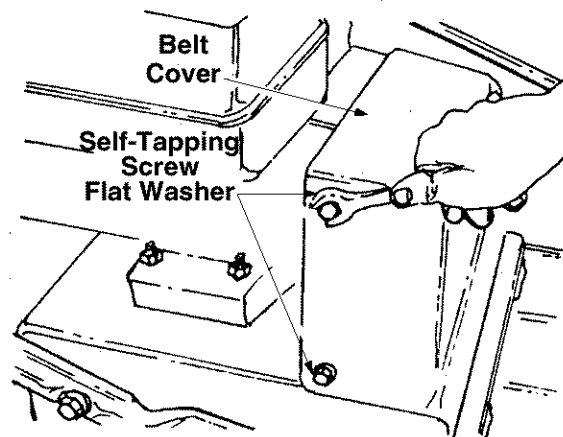

Figure 17

3. Remove the large shoulder bolt and washer on the left hand side of the engine pulley with an adjustable wrench. Refer to Figure 18.

NOTE: Reference to right hand or left hand side of machine are observed from the operating position.

4. Remove the cotter pin and washer from the ferrule in order to disconnect the auger idler rod from the brake bracket assembly as shown in Figure 19.
5. Slip the auger control belt (the front belt) off the engine pulley. Refer to Figure 19.
6. Pull the brake bracket assembly towards the cable guide roller and unhook the auger cable "Z" fitting.
7. Remove the top screws and lock washers which attach the auger housing assembly to the frame assembly. A 9/16" wrench is required. Refer to Figure 20.

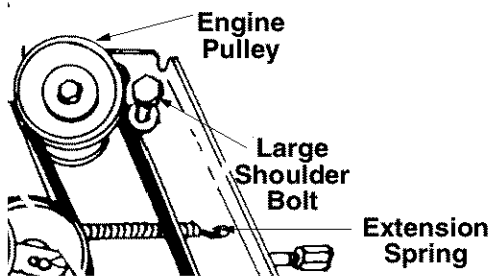

Figure 18

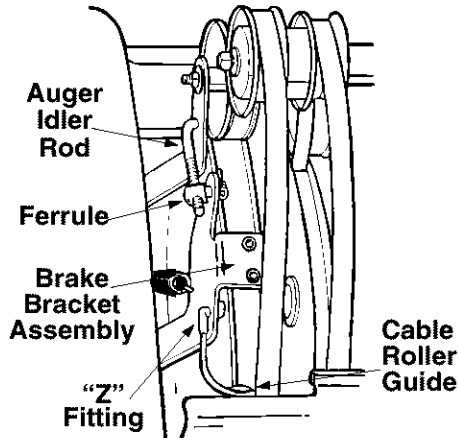

Figure 19

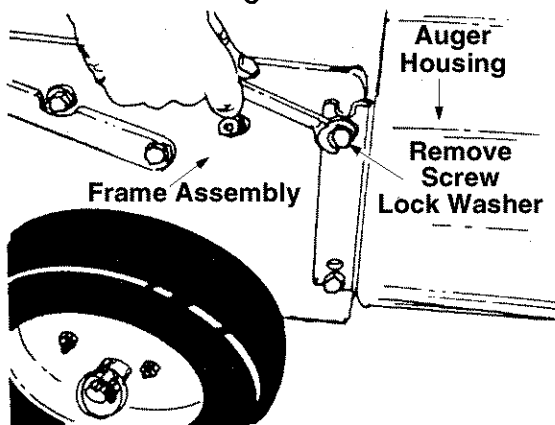

Figure 20

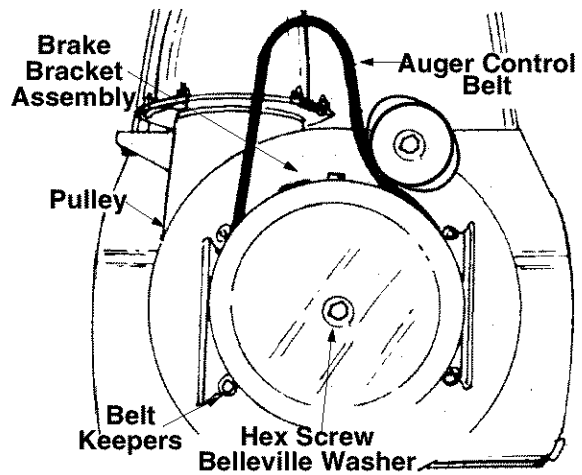

Figure 21

Proper Adjustment With the auger clutch lever in the disengaged position the top surface of the new belt should be even with the outside diameter of the pulley. To adjust, disconnect ferrule from the brake bracket assembly and thread ferrule in (towards idler) to increase tension on belt, out to decrease tension.

NOTE: The brake puck must always be firmly seated in the pulley groove when the auger clutch lever is in the disengaged position.

Drive Belt

1. Unhook extension spring from the belt cover plate. See Figure 18.
 2. Remove drive belt from the engine pulley and bottom drive pulley.
 3. Replace belt and reassemble in reverse order.
 4. Reassemble the two halves of the unit hooking the lower portion of the auger housing over the stationary shoulder bolts in the frame assembly.
 5. Secure the two halves with the two screws and lock washers
 6. Attach the "Z" fitting of the cable into the brake bracket assembly. See Figure 19.
 7. Slip the auger control belt over engine pulley.
 8. Insert ferrule on auger idler rod into bracket assembly and secure with flat washer and cotter pin.
 9. Reassemble the large shoulder bolt and lock washer as shown in Figure 18.
 10. Reassemble belt cover and chute directional control.
 11. Remove plastic film from gas cap.
8. Separate the auger housing from the frame assembly by tilting the housing forward and pulling up the handles.
 9. Using a 1/2" wrench remove the hex screw and belleville washer from the centre of the pulley on the auger housing. Lift the brake bracket assembly out of the pulley groove and remove the pulley. See Figure 21. Be careful not to lose the key.
 10. Remove and replace auger belt inside belt keepers.
 11. Reassemble pulley to auger housing with hex screw and belleville washer (cupped is toward the pulley). Be certain key is in place on shaft and brake puck is seated in the pulley groove.

Changing the Friction Wheel

The rubber on the friction wheel is subject to wear and should be checked after 25 hours of operation, and periodically thereafter. Replace the friction wheel rubber if signs of excessive wear or cracking are found.

1. Drain the gasoline from the snow thrower, or place a piece of plastic under the gas cap.
2. Tip the snow thrower up and forward, so that it rests on the housing.
3. Remove six self-tapping screws from the frame cover underneath the snow thrower.
4. Remove the wheels from the axle.
5. Using a 7/8" wrench hold the hex shaft and remove the hex bolts and cupped washer and bearing from left side of the frame. See Figure 15. Hold the friction wheel assembly, and slide the hex shaft out of the unit toward the right hand side.
6. Remove the six screws from the friction wheel assembly (three from each side).
7. Reassemble new bonded friction wheel rubber to the friction wheel assembly, tighten the six screws in rotation and with equal force. See Figure 22.

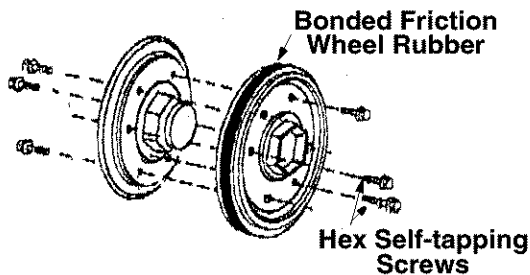

Figure 22

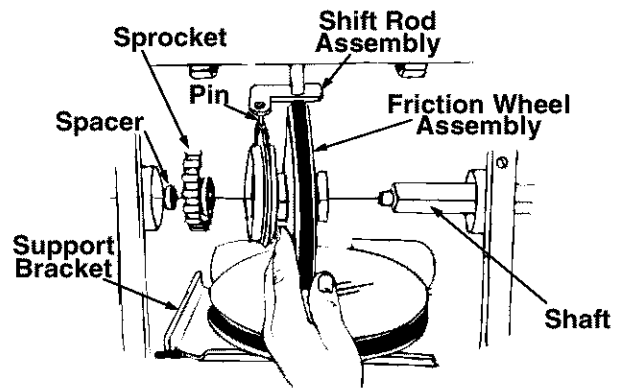

Figure 23

8. Position the friction wheel assembly up onto the pin of the shift rod assembly and slide the shaft through the friction wheel. See Figure 23.
9. Slide the hex shaft into the hex I.D. of the sprocket, the spacer and the left ball bearing and secure with the bell washer and hex bolt.

NOTE: Make sure the pin from the shift arm assembly is assembled to the new friction wheel assembly.



CAUTION: Check engine and snow thrower frequently for loose nuts, bolts, etc. and keep these items tightened.

SECTION 10: OFF-SEASON STORAGE



WARNING: Never store engine with fuel in tank indoors or in poorly ventilated areas where fuel fumes may reach an open flame, spark or pilot light as on a furnace, water heater, clothes dryer or other gas appliance.

1. If unit is to be stored over 30 days, prepare engine for storage as instructed in the separate engine manual included with your unit.
2. Remove all dirt from exterior of engine and equipment.

3. Follow lubrication recommendations on page 10.
4. Store in a clean, dry area.

NOTE: When storing any type of power equipment in an unventilated or metal storage shed, care should be taken to rust proof the equipment. Using a light oil or silicone, coat the equipment, especially any chains, springs, bearings and cables.

SECTION 11: TROUBLE SHOOTING GUIDE

Trouble	Possible Cause(s)	Corrective Action
Engine fails to start	Fuel tank empty, or stale fuel. Blocked fuel line. Choke not in ON position Faulty spark plug. Key not in switch on engine. Spark plug wire disconnected. Primer button not depressed. Fuel shut-off valve closed	Fill tank with clean, fresh gasoline. Fuel will not last over thirty days unless a fuel stabilizer is used. Clean fuel line. Move switch to ON position Clean, adjust gap or replace. Insert key. Connect spark plug wire. Refer to the engine manual packed with your unit. Open fuel shut-off valve.
Engine runs erratic	Unit running on CHOKE. Blocked fuel line or stale fuel. Water or dirt in fuel system. Carburetor out of adjustment.	Move choke lever to OFF position. Clean fuel line; fill tank with clean fresh gasoline. Fuel will not last over thirty days unless a fuel stabilizer is used. Drain fuel tank. Refill with fresh fuel. Refer to the engine manual packed with your unit or have carburetor adjusted by an authorized service dealer.
Loss of power	Spark plug wire loose. Gas cap vent hole plugged. Exhaust port plugged.	Connect and tighten spark plug wire. Remove ice and snow from cap. Be certain vent hole is clear. Clean-see Maintenance section of engine manual.
Engine overheats	Carburetor not adjusted properly.	Refer to the engine manual packed with your unit or have carburetor adjusted by an authorized service dealer.
Excessive vibration	Loose parts or damaged auger.	Stop engine immediately and disconnect spark plug wire. Tighten all bolts and nuts. Make all necessary repairs. If vibration continues, have unit serviced by an authorized service dealer.
Unit fails to propel itself	Incorrect adjustment of drive cable. Drive belt loose or damaged.	Adjust drive cable. Refer to Adjustment section of this manual. Replace drive belt. Refer to Belt Replacement in Maintenance section of this manual.
Unit fails to discharge snow	Discharge chute clogged. Foreign object lodged in auger. Incorrect adjustment of drive cable. Drive belt loose or damaged.	Stop engine immediately and disconnect spark plug wire. Clean discharge chute and inside of auger housing. Stop engine immediately and disconnect spark plug wire. Remove object from auger. Adjust drive cable. Refer to Adjustment section of this manual. Replace drive belt. Refer to Belt Replacement in Maintenance section of this manual.

Note: For repairs beyond the minor adjustments above, contact your local authorized service dealer.

SECTION 12: Illustrated Parts
Model 993

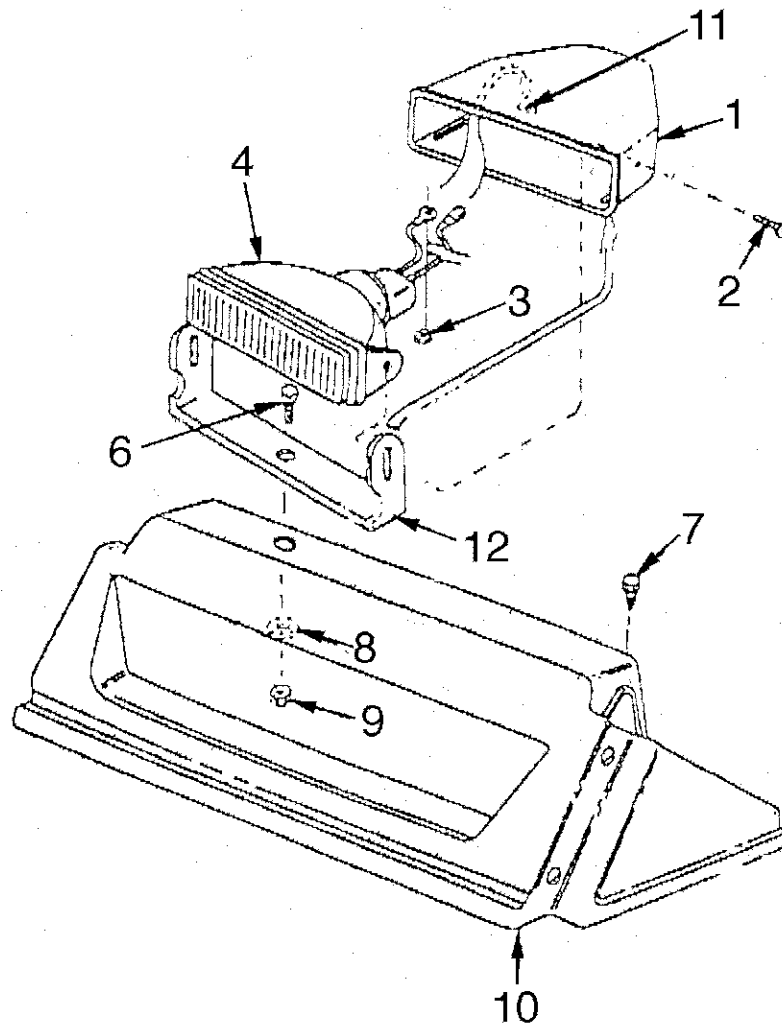

Ref. No.	Part No.	Description	Qty.
1	731-1364	Halogen Lamp Housing	1
2	710-1240	Phillips Pan Head Screw M 4 x 16	2
3	712-0271	Hex Sems Nut 1/4-20	1
4	725-1669	Lamp/Lens Housing Ass'y	1
	629-0059	Halogen Light Wire Harness	1
	725-1658	#890 Halogen Bulb	1
6	710-0451	Carriage Bolt 5/16-18 x .75	1
7	710-1003	Pan Head B-Tapp Screw #10	2
8	736-0159	FI-Wash .344 ID x .88 OD	1
9	712-0429	Hex Ins L-Nut 5/16-18	1
10	731-1873A	Handle Panel	1
11	735-0225	Grommet .38 ID x .50 OD x 12	1
12	705-5217	Lamp Mounting Bracket	1

Model 993

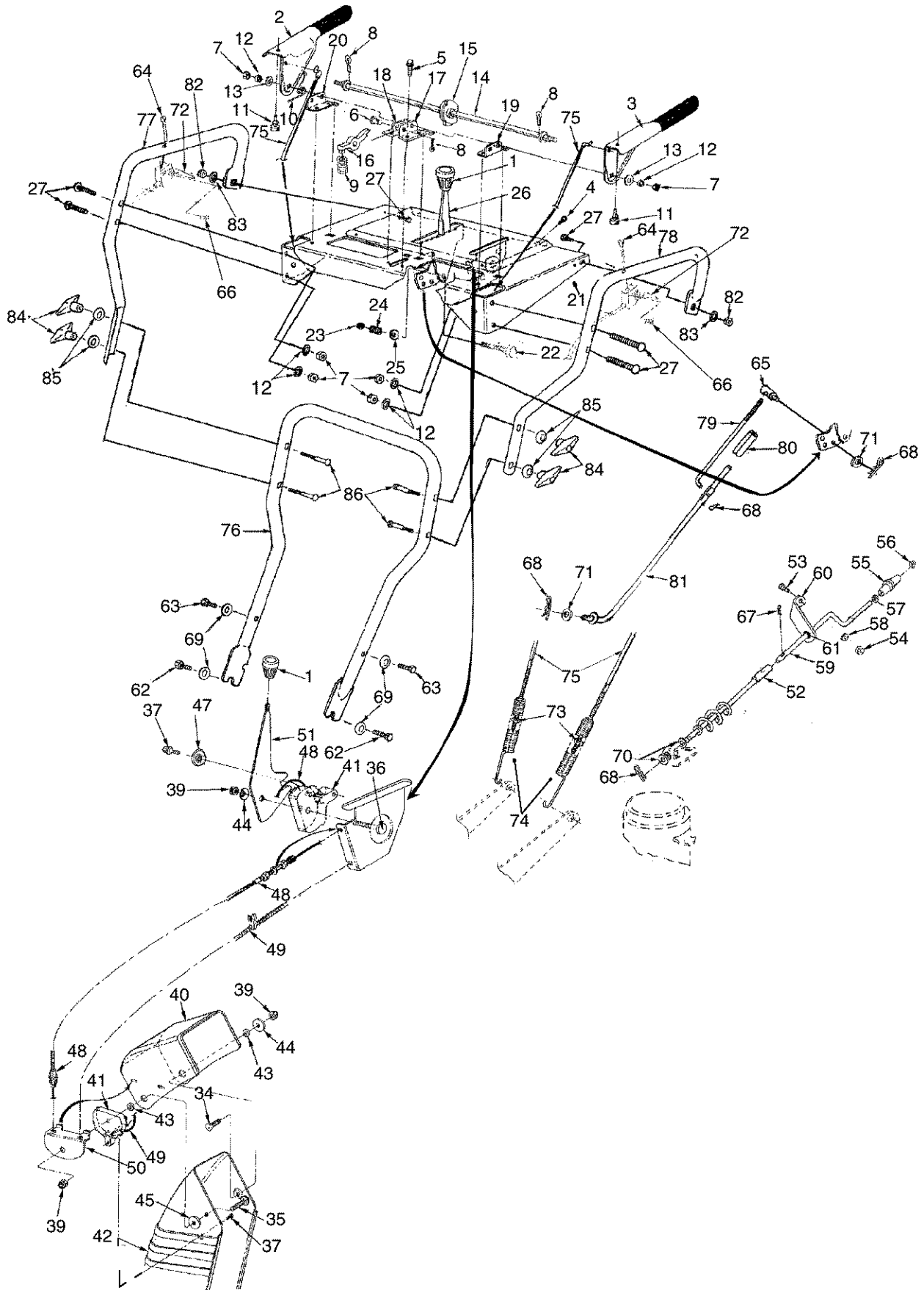

Model 993

Ref. No.	Part No.	Description	Qty.	Ref. No.	Part No.	Description	Qty.
1	720-0232	Sml Shift Knob	2	48	746-0902	Chute Control Cable 66"	1
2	705-5218	Engage Handle RH	1	49	746-0903	Chute Control Cable 66" W/clip	1
3	705-5219	Engage Handl LH	1	50	784-5594	Cable Bracket Chute Tilt	1
4	710-0351	Pan Head B-tapp Scr #10 x .5	2	51	784-5604	Chute Tilt Handle	1
5	710-0599	Hwhd Sf-tap Scr 1/4-20 x 1/2 Lg.	4	52	684-0053A	Lower Chute Directional Control	1
6	711-0653	Clevis Pin .31 Dia x 1.0	1	53	710-3015	Hex Scr 1/4-20 x .75 Lg Gd5	1
7	712-3010	Nut Hex 5/16-18 Gd 5	6	54	712-0287	Hex Nut 1/4-20	1
8	714-0507	Cot-pin 3/32 Dia x 1.0	3	55	720-0201A	Chute Directional Control Knob	1
9	732-0145	Comp Spring .36 Dia x 1.0 Lg	1	56	726-0100	Push Cap 3/8 Palnut #375011	1
10	732-0746	Spring Torsion .44 ID	1	57	736-0117	Flat Washer .38 ID x .60 OD x .033	1
11	735-0199A	Rubber Bumper .63 Dia	2	58	736-0270	Bell Wash .26 ID x .75 OD x .06T	1
12	736-0119	Lock Washer 5/16	6	59	747-0624	Upper Chute Directional Control	1
13	736-0509	Wshwr Spl. .345 Sq. x .72 OD	2	60	705-5266	Brkt Chute Directional Control	1
14	747-0877	Cam Rod	2	61	741-0475	Plastic Bushing .380 ID	4
15	748-0362	Clutch Lock Cam	2	62	710-0216	Hex Scr 3/8-16 x .75	2
16	748-0363	Clutch Lock Pawl	1	63	710-0347	Hex Scr 3/8-16 x 1.75	2
17	784-5679	Supt Brkt 5/8 Lh	1	64	710-1625	Scr Oval C/sunk #10-24 x 1.75	2
18	784-5680	Supt Brkt 5/8 Rh	1	65	711-0677	Adjustment Ferrule	1
19	784-5681	Supt Brkt 3/8 Lh	1	66	712-0127	#10-24 Flat Weld Nut	2
20	784-5682	Supt Brkt 3/8 Rh	1	67	714-0101	Internal Cot-pin 1/2 Dia	1
21	684-0102	Pnl Asm Hndl W/tilt	1	68	714-0104	Inter Cot-pin 5/16 Dia	4
22	710-0459A	Scr Hex Cap 3/8-24 x 1.5 Gd 5	1	69	736-0105	Bell Wash .4 ID x .88 OD x .06	4
23	712-0116	Hex Ins L-nut 3/8-24	1	70	736-0185	Fl-wash .406 ID x .74 OD x .063	2
24	732-0193	Compression Spring .39 ID x .88	1	71	736-0275	Fl-wash Sae .34 x .68 x .062	2
25	736-0105	Bell Wash .40 ID x .88 OD x .06	1	72	746-0950	Trigger Ass'y Steer	2
26	784-5619A	Shift Handle	1	73	712-0324	Hex Ins L-nut 1/4-20	2
27	710-0458	Carriage Bolt 5/16-18 x 1.75	6	74	732-0184	Extension Spring	2
34	710-0276	Carriage Bolt 5/16-18 x 1.00	1	75	746-0952	Cable Clutch Drive	2
35	710-0458	Carriage Bolt 5/16-18 x 1.75	1	76	646-0012	Handle Lower	2
36	710-0805	Hex Scr 5/16-18 x 1.5	1	77	749-0990A	Handle Upper Rh	1
37	710-0896	HWHd B Tapp Scr 1/4 x 5/8 Zn	2	78	749-0989A	Handle Upper Lh	1
39	712-0429	Hex Ins L-nut 5/16-18	3	79	747-0997	Upper Shift Rod 5/16 x 10.57	1
40	731-0846C	6" Upper Chute Remote Tilt	1	80	750-0963	2 Pc Shift Rod Connector	1
41	731-1313C	Chute Tilt Cable Guide	2	81	747-0983	Lower Shift Rod 3/8 x 14.75	1
42	731-0903D	6" Lower Chute Remote Tilt	1	82	712-0287	Hex Nut 1/4 - 20	2
43	731-1319	Chute Pivot Spacer	2	83	736-0270	Bell Wash .26 ID x .75 OD x .06T	2
44	736-0159	Fl-wash .344 ID x .88 OD x .063	2	84	720-0284	Wingnut	4
45	736-0231	Flt Wshr .344 x 1.125 x .125	1	85	736-0242	Bell Wash .345 ID x .88 OD x .060	4
47	736-0506	Contoured Washer	1	86	710-0572	Carriage Bolt 5/16 -18 x 2.5	4

NOTE: For painted parts, please refer to the list of color codes below. Please add the applicable color code, wherever needed, to the part number to order a replacement part. For instance, if a part, numbered 700-xxxx, is painted yard-man green, the part number to order would be 700-xxxx-0665.

Yard-Man Green: 0665
 Yard-Man Yellow: 0674
 Powder Black: 0637

Model 993

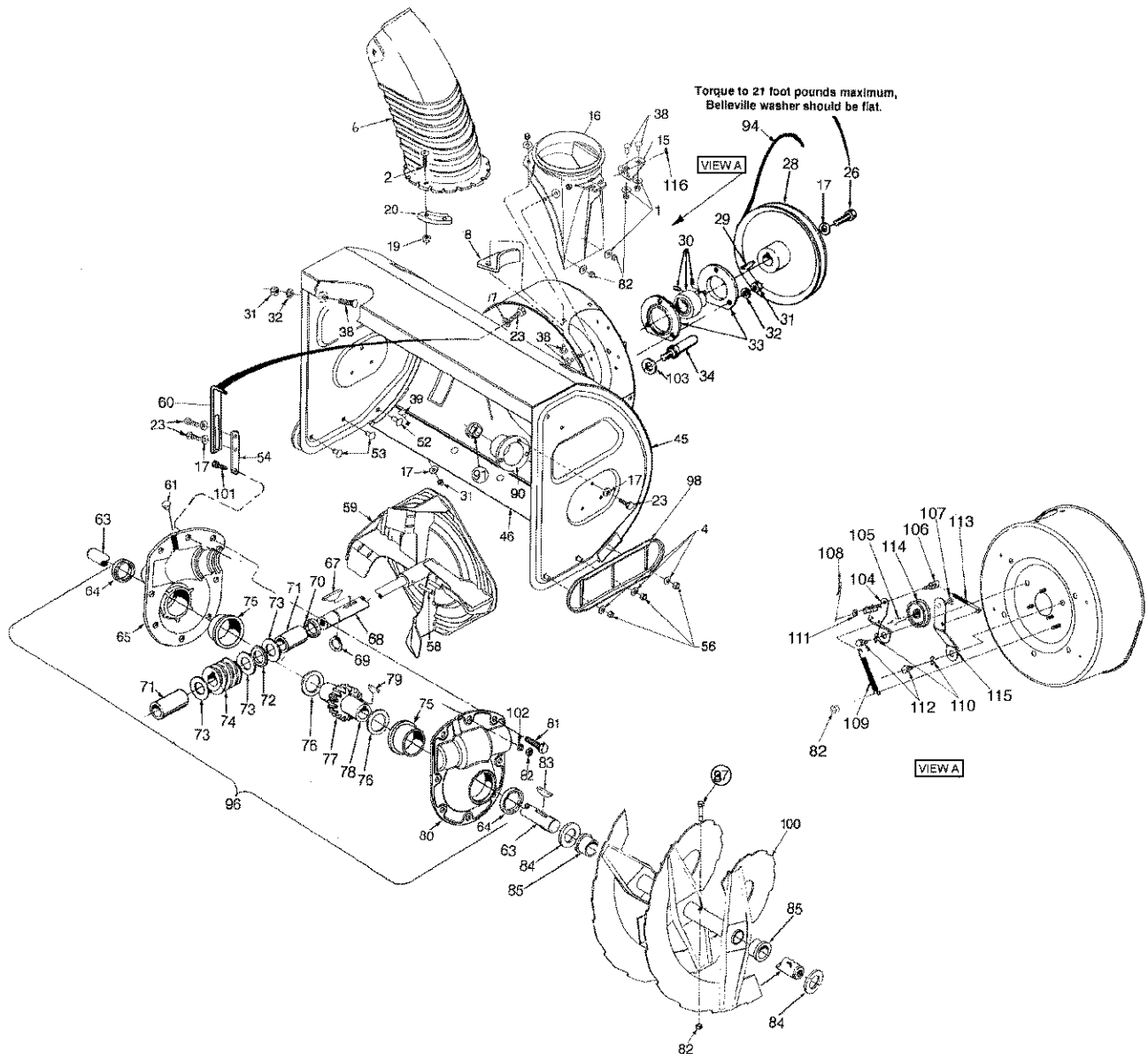

Model 993

Ref. No.	Part No.	Description	Qty.	Ref. No.	Part No.	Description	Qty.
1	736-0159	Flat Washer .344 ID x .875 OD	7	72	741-0184	Thrust Bearing .88 ID x 1.44 OD x .078	1
2	710-3015	Truss. Hd. Mach. Scr. 1/4-20 x .75	6				
4	736-0105	Belleville washer	6	73	736-0291	Flat Washer .88 ID x 1.4 OD x .125	3
6	731-0903D	6" Lower Chute Remote Tilt	1	74	717-0299	Worm Gear LH Double Thread	1
8	784-5711	Chute Bracket	1	75	741-0670	Flange Brg. 1.5 ID x 1.75 OD x .80	2
15	784-5123	Chute Bracket	1	76	736-0266	Flat Washer 1.5 ID x 2.0 OD x .03	2
16	731-1696	Chute Adapter	1	77	717-1425	Worm Gear LH Double Thread (Bronze)	1
17	736-0242	Bell. Washer .345 ID x .88 OD x .06	15				
19	712-3027	Hex Cent. L-Nut 1/4-20 w/ Flange	6	78	738-0275	Worm Gear Shaft	1
20	731-0851A	Chute Flange Keeper	3	79	714-0135	#91 Woodruff Key 1/4 x 3/4 dia	1
23	710-0601	Hex Wash HD Self-Tap Scr 5/16-18 x .75	9	80	719-0349	Gear Housing Half LH	1
				81	710-1260A	Hex Flange Scr. 5/16-18 x .75	7
26	710-0371	Hex Screw 5/16-18 x .75	1	82	712-0429	Hex Ins. L-Nut 5/16-18	12
28	756-0243	1/2" V-Pulley .875 ID x 10.12 OD	1	83	714-0135	#91 Woodruff Key 1/4 x 3/4 dia	1
29	714-0126	#9 Hi-Pro Key 3/16 x 3/4 Dia HT	1	84	736-0250	Flat Washer	4
30	741-0185	Self-Aligning Bearing .875 ID	1	85	741-0494	Flange Bearing	4
31	712-3010	Hex Nut 5/16-18 GD. 5	12	87	710-0891	Shear Bolt 5/16-18 x 1.75	2
32	736-0119	L-Wash 5/16 ID	7	90	05845B	Housing bearing 1.5 Dbl D	2
33	05244A	Bearing Housing	2	91	741-0192	Flange Bearing w/flats	2
34	711-0640	Belt Keeper Studs 3/8-16 x 2.75	5	94	754-0222	V-Belt 1/2 x 44 LG	1
38	710-0451	Carriage Bolt 5/16-18 x .75	16	96	618-0257	Worm Gear Box Ass'y	1
45	684-0093A	33" Snowthrower Hsg. Ass'y	1	98	784-5697	Reversible Skid Shoe	2
46	784-5714	Shave Plate 33"	1	100	705-5210A	RH Spiral Ass'y Serrated - 33"	1
52	710-3168	Carriage Bolt 3/8-16 x 1.00 Gr. 5	2		705-5211A	LH Spiral Ass'y Serrated - 33"	1
53	710-0389	Carriage Bolt 3/8-16 x .75" Lg.	4	101	710-0528	Hex Scr 5/16-18 x 1.25	1
54	784-5710	Gear Housing Support Plate 1 x 3/16	1	102	736-0271	5/16 Sprg Wash	1
56	712-0798	Hex Jam Nut 3/8-16	6	103	736-0169	3/8 Sprg Lock Wash	5
58	715-0118	Spring Spiral Pin Heavy 5/16 dia x 1.7	2	104	618-0281	Brkt Ass'y Brkt	1
59	684-0090	Blower Fan Ass'y Complete	1	105	710-0459A	Scr Hex Cap 3/8-24 x 1.5 GRD 5	1
60	784-5076	Gear housing Support Bracket 1 x 3/16	1	106	711-0677	Adjustment Ferrule	1
				107	712-0116	Hex Ins L-Nut 3/8-24	1
61	721-0325	Barbed Plug	1	108	714-0104	Intern Cot-Pin 5/16 dia	1
63	738-0491	Spiral Axle -33"	1	109	732-0858	Spr Extn .470 dia x 4.75 Lg	1
64	721-0146	Oil Seal 1.50 ID Garlock (76 x 6223)	2	110	736-0174	Wave Washer .66 ID x .88 OD	2
65	719-0348	Gear Housing Half - RH	1	111	736-3008	Fl-Wash SAE .34 x .68	1
67	714-0126	#9 Hi-Pro Key 3/16 x 3/4 dia HT	1	112	738-0281	Shld Scr .625 dia x .170 x .062	2
68	711-1133	Auger Control Shaft	1	113	747-0980	Rod Idler Auger	1
69	716-0111	Snap Ring for .875 dia. shaft	1	114	756-0240	3.0 OD Flat Idler with Flanges	1
70	721-0145	Oil Seal for .875 ID (76 x 6133)	1	115	784-0385	Brkt Idlr Auger	1
71	741-0217	Sleeve Bearing .875 ID	2	116	741-0475	Plastic Bushing .380 ID	1

NOTE: For painted parts, please refer to the list of color codes below. Please add the applicable color code, wherever needed, to the part number to order a replacement part. For instance, if a part, numbered 700-xxxx, is painted yard-man green, the part number to order would be 700-xxxx-0665.

Yard-Man Green: 0665
Yard-Man Yellow: 0674
Powder Black: 0637

Model 993

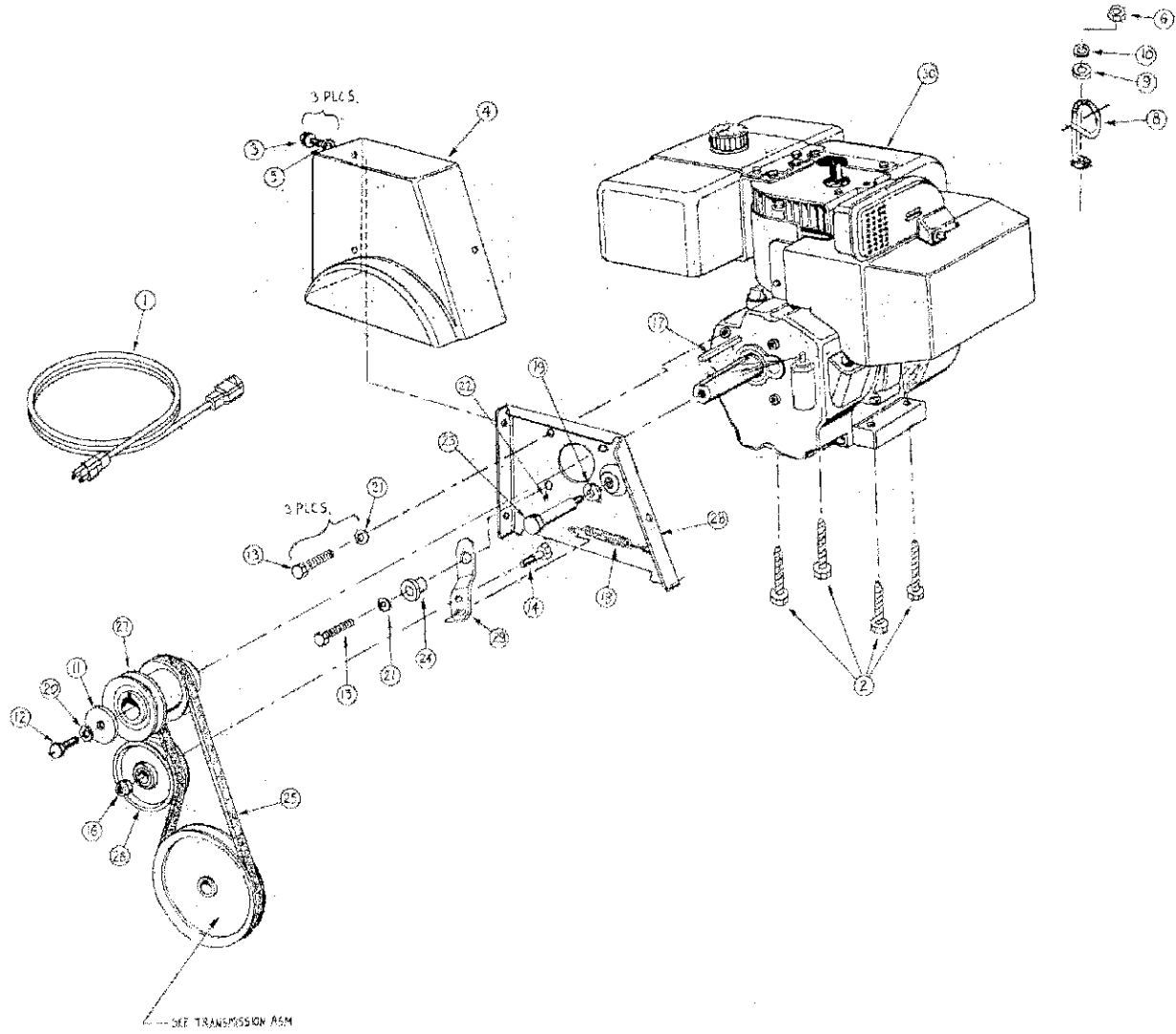

Model 993

Ref. No.	Part No.	Description	Qty.	Ref. No.	Part No.	Description	Qty.
1	629-0071	Extension Cord 10 Ft.	1	17	714-0118	Square Key 1/4 X 1.5	1
2	710-0502A	Hex L-wash Tt Scr 3/8-16 X 1.25	4	18	732-0303	Extension Spring .38 OD X 3.18 L	1
3	710-0607	Hwhd 5/16-18 X 1/2 Thd Roll Zn	3	19	736-0169	L-wash 3/8	1
4	731-0321-1	Belt Cover - Pierced	1	20	736-0217	Lock Washer 3/8 Heavy	1
5	736-0264	Fl-wash .344 ID X .625 OD X .063	3	21	736-0242	Bell Wash .345 ID X .88 OD X .060	4
6	712-3006	Nut 1/4-20 GR B Hex	1	22	737-0157	Grease - Sunaplex 781 - 1/10	1
8	732-0705	Cable Control Wire	1	23	738-0215A	Shoulder Scr .498 Dia X 3.0 Lg	1
9	736-0173	Fl-Wash .28 ID x .74 OD x .063	1	24	748-0234	Shldr Spcr .50 Dia X .14 Shldr	1
10	736-0329	Lock Washer 1/4	1	25	754-0131	3v Belt 35.5 Lg	1
11	07386	Wash .39 ID X 1.75 OD X .175 T	1	26	756-0240	3.0 OD Flat Idler With Flange	1
12	710-0191	Scr Hex Cap 3/8-24 X 1. Gd 8	1	27	756-0241B	Dbl Engine Pulley 3.25 & 2.75	1
13	710-0237	Scr Hex Cap 5/16-24 X .62 Gd 5	3	28	684-0123A	Brkt Asm Cvr Belt 12 HP	1
14	710-0459	Scr Hex Cap 3/8-24 X 1.5 Gd 5	1	29	784-5726	Brkt Idlr Dr	1
15	710-1245	Hhcs 5/16-24 X 7/8 Gr 5	1	30	-	Engine	1
16	712-0116	Hex Ins L-nut 3/8 - 24	1				

IMPORTANT: For a proper working machine, use Factory Approved Parts.

V-BELTS are specially designed to engage and disengage safely. A substitute (non OEM) V-Belt can be dangerous by not disengaging completely

Model 993

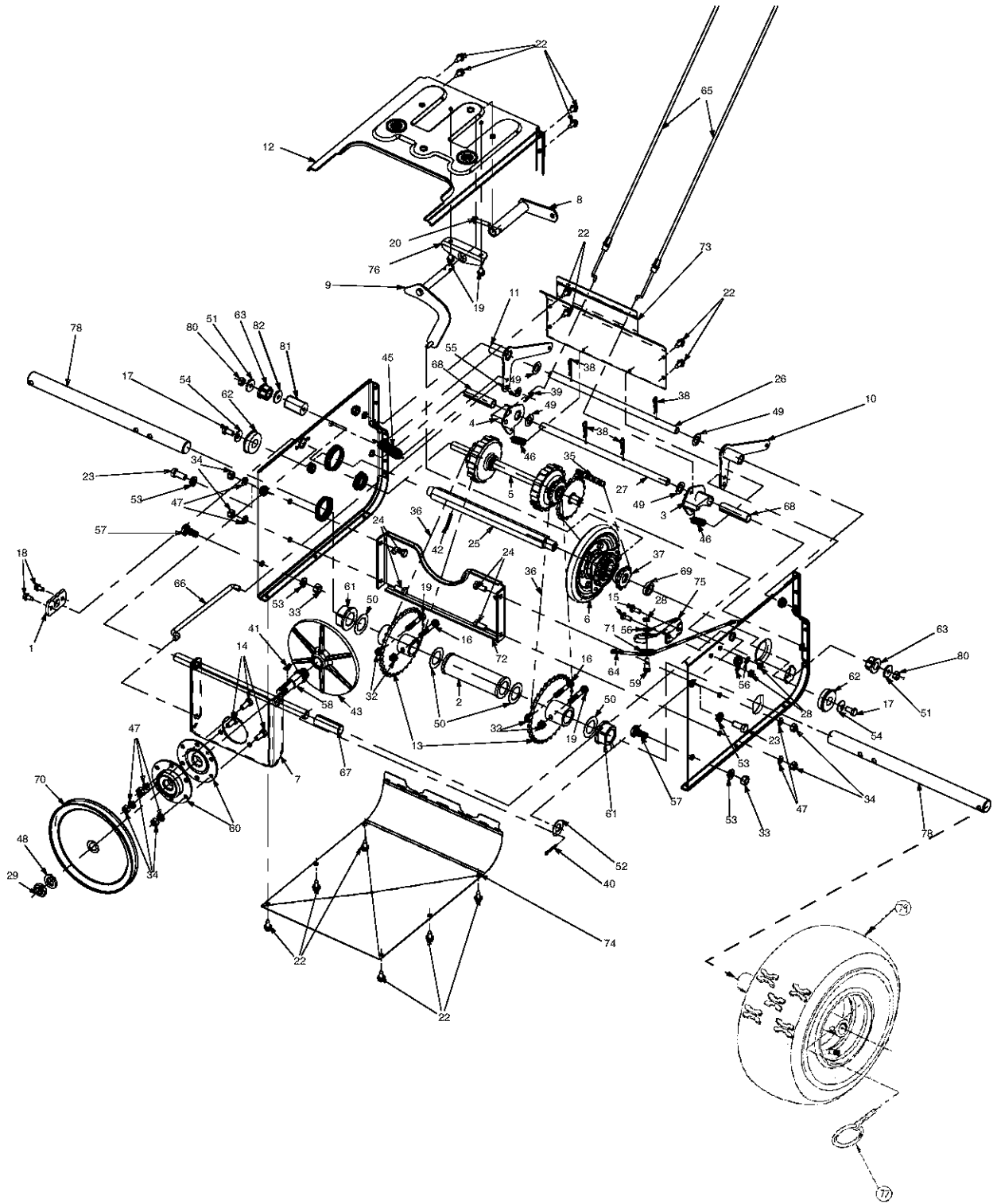

Model 993

Ref. No.	Part No.	Description	Qty.	Ref. No.	Part No.	Description	Qty.
1	05523	Pivot Axle Brkt. .63 Hole - Zinc	1	43	717-0302	Aluminum Drive Plate	1
2	618-0278	Bush Asm slev	1	45	732-0121	Idler Extension Spring	1
3	618-0279	Dogg Asm Dr Lh	1	46	732-0209	Extension Spring	2
4	618-0280	Dogg Asm Dr Rh	1	47	736-0119	Lock Washer 5/16	7
5	618-0282A	Shf Asm Dr	1	48	736-0158	Lock Washer 5/8	1
6	618-0296	Whl Asm Brg 6.0 OD Friction	1	49	736-0160	Wash Fl .531 ID x .930 OD x .05	4
7	684-0115	Brkt Asm Supt Friction Dr	1	50	736-0163	Wash Fl 1.03 ID x 1.62 OD	4
8	684-0116	Arm Asm Shift	1	51	736-0300	Wash Flt 1/4 ID x .930 OD x .12	2
9	684-0117	Shft Asm Rod	1	52	736-0623	Wash Flt .640 ID x 1.24 OD x .06	1
10	684-0118	Brkt Asm Actr Auger	1	53	736-0217	Lock Washer 3/8 Heavy	4
11	684-0119	Brkt Asm Actr Dr	1	54	736-0242	Bell Wash .345 ID x .88 OD	2
12	684-0120	Frm Asm Trans	1	55	736-0275	FI-wash Sae .34 x .68 .062	1
13	684-0122	Spkt Asm 32t	2	56	736-0329	Lock Washer 1/4	5
14	710-3008	Hex Scr 5/16-18 x .75	3	57	738-0143	Shld Scr .498 Dia x .340	2
15	710-0195	Hhcs 1/4-28 .625 Gr5 std	2	58	738-0279	Drive Plate Spindle	1
16	710-3180	Hex Scr 5/16-18 x 2.00	2	59	738-0924	Scr Shldr .340 D. 1/4 Ab	1
17	710-0538	Hhcs 5/16-18 x .625 Gr5 Lock	2	60	741-0163A	Asm Brg Hsg	2
18	710-0599	Scr TT 1/4-20 x .5 Hxindwsh	4	61	741-0192	Flange Brg Pm W/flts 1.0	2
19	710-3103	Hex Scr 5/16-18 2.00 Lg	2	62	741-0563	Ball Bearing W/snap Ring	2
20	710-0788	Scr Hexwash 1/4-20 x 2.00	1	63	741-0597	Brg Hex Flange x .564 ID	2
22	710-1652	Scr Ab 1/4-14 .625 Hxindwsh	14	64	746-0951	Cb Idlr Auger	1
23	710-3001	Hhcs 3/8-16 x .880 Gr5 Std	2	65	746-0949	Cbl Strg	2
24	710-3008	Scr Cap 5/16-18 x .75 Gr 5	4	66	747-0973	Rod Clu Dr	1
25	711-1191	Shf Dr .875 Hex	1	67	750-1097	Spcr Splt .64 x .77 x 2.1	1
26	711-1193	Shf Sctr	1	68	750-0903	Split Spacer 1/2 x 5/8 x 2.44	2
27	711-1194	Shf Actr Dr	1	69	750-0997	Spcr .675 ID x 1.00 OD x .23	1
28	712-0138	Hex Nut 1/4-28	3	70	756-0344	1/2 V-pulley .62 ID x 7.5	1
29	712-0221	Hex Ins Jam L-nut 5/8-18	1	71	756-0625	Cable Guide Roller	1
32	712-0429	Hex Ins L-nut 5/16-18	4	72	784-0377	Brkt Supt Frm	1
33	712-0798	Hex Nut 3/8-16	2	73	784-0379	Cvr Frm Upr	1
34	712-3010	Nut Hex 5/16-18 Gd 5	7	74	784-0380	Cvr Frm Lwr	1
35	713-0284	#41 Chain 1/2 Pitch x 36 L	1	75	784-0384	Brkt Gde Auger Cbl	1
36	713-0286	#420 Chain 1/2 Pitch x 40 L	2	76	784-5590	Shift Bracket Frame	1
37	713-0413	Spkt 10t #41 x .500	1	77	714-0151A	Klik Pin Assy Danuse	2
38	714-0101	Internal Cot-pin 1/2 Dia	4	78	738-0975	Axle 1.0 OD x 14.1 Lg	2
39	714-0104	Intern Cot-pin 5/16 Dia	1	79	734-1593	Cmp. Whl. Assy 16 x 6.5 Snohog	2
40	714-0115	Cotter Pin 1/8 Dia x 1	1	80	712-0116	Hex Jam Nut 3/8-24 Thd.	2
41	714-0388	#61 Hi-pro-key 3/16 x 5/8	1	81	750-1196	Spacer	1
42	715-0249	Spring Pin Roll 5/32	1	82	736-0639	FI-Washer	1

NOTE: For painted parts, please refer to the list of color codes below. Please add the applicable color code, wherever needed, to the part number to order a replacement part. For instance, if a part, numbered 700-xxxx, is painted yard-man green, the part number to order would be 700-xxxx-0665.

Yard-Man Green: 0665
Yard-Man Yellow: 0674
Powder Black: 0637

MANUFACTURER'S LIMITED WARRANTY FOR:



The limited warranty set forth below is given by MTD PRODUCTS INC ("MTD") with respect to new merchandise purchased and used in the United States, its possessions and territories.

MTD warrants this product against defects in material and workmanship for a period of two (2) years commencing on the date of original purchase and will, at its option, repair or replace, free of charge, any part found to be defective in material or workmanship. This limited warranty shall only apply if this product has been operated and maintained in accordance with the Operator's Manual furnished with the product, and has not been subject to misuse, abuse, commercial use, neglect, accident, improper maintenance, alteration, vandalism, theft, fire, water or damage because of other peril or natural disaster. Damage resulting from the installation or use of any accessory or attachment not approved by MTD Products Inc. for use with the product(s) covered by this manual will void your warranty as to any resulting damages.

Normal wear parts or components thereof are subject to separate terms as follows: All normal wear part or component failures will be covered on the product for a period of 90 days regardless of cause. After 90 days, but within the two year period, normal wear part failures will be covered ONLY IF caused by defects in material or workmanship of OTHER component parts. Normal wear parts and components include, but are not limited to, belts, blades, blade adapters, grass bags, rider deck wheels, seats, snow thrower skid shoes, shave plates and tires. Batteries are covered by a 90-day limited replacement warranty.

HOW TO OBTAIN SERVICE: Warranty service is available, WITH PROOF OF PURCHASE THROUGH YOUR LOCAL AUTHORIZED SERVICE DEALER. To locate the dealer in your area, please check for a listing in the Yellow Pages or contact the Customer Service Department of MTD PRODUCTS INC by calling 1-800-800-7310 or writing to P.O. Box 368022, Cleveland, Ohio 44136-9722. No product returned directly to the factory will be accepted unless prior written permission has been extended by the Customer Service Department of MTD PRODUCTS INC.

This limited warranty does not provide coverage in the following cases:

- a. The engine or component parts thereof. These items carry a separate manufacturer's warranty. Please refer to the applicable manufacturer's warranty on these items.

- b. Routine maintenance items such as lubricants, filters, blade sharpening and tune-ups, or adjustments such as brake adjustments, clutch adjustments or deck adjustments; and normal deterioration of the exterior finish due to use or exposure.
- c. Log splitter pumps, valves and cylinders have a separate one year warranty.
- d. MTD does not extend any warranty for products sold or exported outside of the United States of America, its possessions and territories, except those sold through MTD's authorized channels of export distribution.

No implied warranty, including any implied warranty of merchantability or fitness for a particular purpose, applies after the applicable period of express written warranty above as to the parts as identified. No other express warranty or guaranty, whether written or oral, except as mentioned above, given by any person or entity, including a dealer or retailer, with respect to any product shall bind MTD. During the period of the Warranty, the exclusive remedy is repair or replacement of the product as set forth above. (Some states do not allow limitations on how long an implied warranty lasts, so the above limitation may not apply to you.)

The provisions as set forth in this Warranty provide the sole and exclusive remedy arising from the sales. MTD shall not be liable for incidental or consequential loss or damages including, without limitation, expenses incurred for substitute or replacement lawn care services, for transportation or for related expenses, or for rental expenses to temporarily replace a warranted product. (Some states do not allow the exclusion or limitation of incidental or consequential damages, so the above exclusion or limitation may not apply to you.)

In no event shall recovery of any kind be greater than the amount of the purchase price of the product sold. Alteration of the safety features of the product shall void this Warranty. You assume the risk and liability for loss, damage, or injury to you and your property and/or to others and their property arising out of the use or misuse or inability to use the product.

This limited warranty shall not extend to anyone other than the original purchaser, original lessee or the person for whom it was purchased as a gift.

How State Law Relates to this Warranty: This limited warranty gives you specific legal rights, and you may also have other rights which vary from state to state.